

\$30

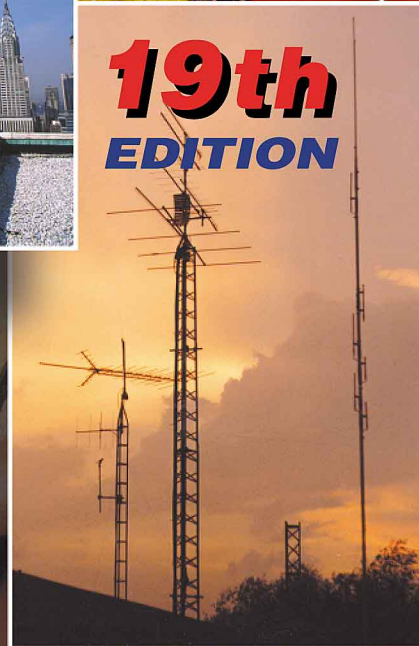
**THE ARRL**

# ANTENNA BOOK



**19th  
EDITION**

**The ultimate  
reference  
for Amateur Radio  
antennas,  
transmission lines  
and propagation**



**CD-ROM  
INCLUDED**



**Welcome to the 19<sup>th</sup> Edition of *The ARRL Antenna Book*!** During the past 60 years we've sold almost a million copies of *The ARRL Antenna Book*, making it one of the most successful ARRL books ever published. In it, you'll find not only the detailed theory behind antennas, transmission lines and propagation, but a wealth of practical, how-to construction projects for all types of antennas and skill levels.

This new edition contains many updates and revisions—in fact, about 40% is either new or has been revised extensively. We are fortunate to have the expertise of some well-respected and highly talented authors: **Kurt Andress**,

**K7NV**, writing about towers and other antenna-support structures; **L. B. Cebik**, **W4RNL**, on Log Periodic Dipole Arrays; **Rudy Severns**, **N6LF**, and **Roy Lewallen**, **W7EL**, on multielement phased arrays; and **Frank Witt**, **A11H**, writing about **broadband antennas**. You'll also find thoroughly updated chapters on **quads**, **long-wire** and **multiband antennas**, written by ARRL staff.

We've upgraded the most popular software programs from the last edition to the full potential of the *Windows* environment: **YW (Yagi for Windows)** and **TLW (Transmission Line for Windows)**. Both programs incorporate new functionality and features, with an intuitive, easy-to-navigate (even fun!) graphical interface.

With publication of the 17<sup>th</sup> Edition of *The ARRL Antenna Book* in 1994, radio amateurs gained much-needed information about the kinds of elevation angles needed for worldwide HF communication. The 19<sup>th</sup> Edition includes even more of the detailed statistical analyses pioneered back in 1994—we now cover a large number of different locations around the world, as well as all around the US. You now have the information you will need to actually design your own system properly—the angles to aim for from your part of the world, together with the effects of your own terrain, as modeled using the acclaimed **YT** program also included with this book.

In addition, summary propagation tables cover all phases of the 11-year solar cycle from more than 140 locations all around the world. You can use these tables to help plan a DXpedition, or to plan when you can expect to work a new DXpedition, months or even years ahead of time.

If you enjoy reading about or experimenting with antennas (and who doesn't), this 19<sup>th</sup> Edition of *The ARRL Antenna Book* is for **you!**

**Software Included**

The ARRL bundles with this book a CD-ROM with high-quality antenna-related software for the IBM PC. Included are two full-featured Windows programs by editor **Dean Straw, N6BV**: **YW (Yagi for Windows)** for analyzing monoband Yagis, and **TLW (Transmission Line for Windows)**, a full-fledged transmission-line and antenna-tuner analysis program. **N6BV** also wrote **AAT**, an antenna-tuner analysis program, and **YT (Yagi Terrain analysis)** an HF terrain-analysis program that includes the effect of diffraction. Want to know if your favorite HF band is supposed to be open next September to southern Africa? The CD-ROM also contains detailed month-by-month propagation predictions for more than 140 worldwide transmitting sites for the whole 11-year solar cycle.

**YW** and **TLW** work in the **Microsoft Windows 95, 98 or 2000** operating environments.



ISBN: 0-87259-804-7 ARRL Order No. 8047

Published by:  
**ARRL** The national association for  
**AMATEUR RADIO**  
225 Main Street • Newington, CT 06111-1494  
<http://www.arrl.org/>

# THE ARRL ANTENNA BOOK



## Editor

R. Dean Straw, N6BV

## Contributing Editors

Kurt Andress, K7NV

L. B. Cebik, W4RNL

Rudy Severns, N6LF

Frank Witt, AI1H

## Software Beta Testers

L. B. Cebik, W4RNL

John Church, G3HCH

Chuck Hutchinson, K8CH

Jose Mata, EA3VY

Danny Richardson, K6MHE

Rudy Severns, N6LF

Jim Tabor, KU5S

Frank Witt, AI1H

## Production

Michelle Bloom, WB1ENT

Sue Fagan—Front Cover

Jodi Morin, KA1JPA

Paul Lappen

Joe Shea

David Pingree, N1NAS

Michael Daniels

## Published by:

**ARRL** *The national association for*  
**AMATEUR RADIO**

225 Main Street

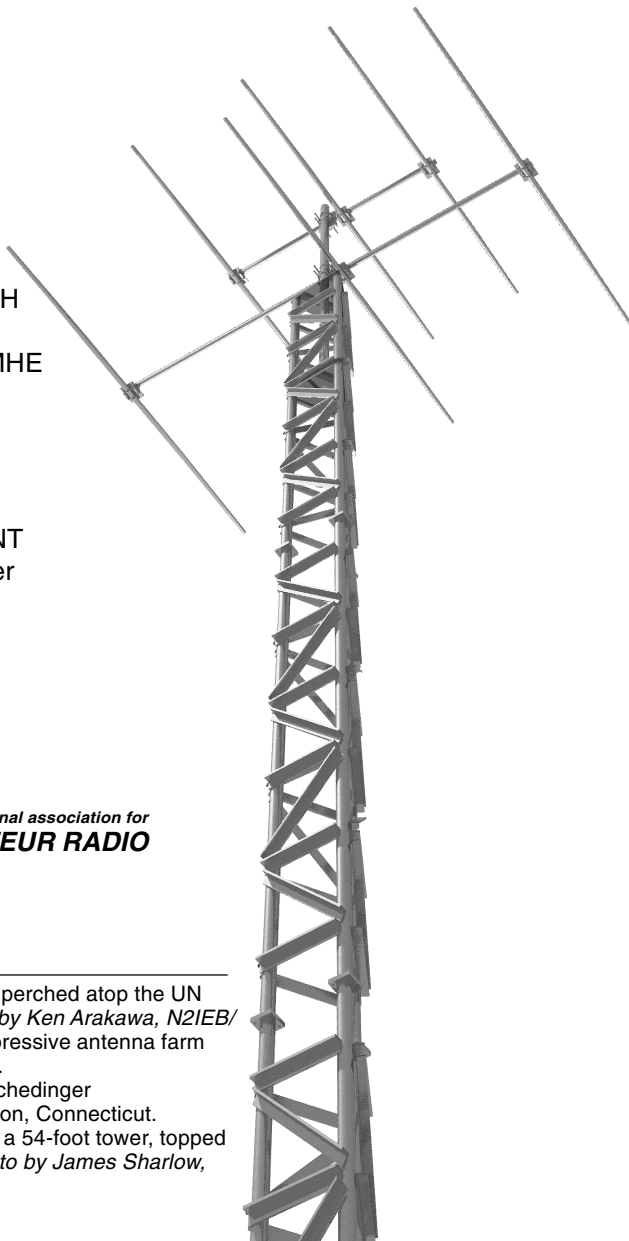
Newington, CT 06111-1494

## The Covers:

*Front cover, center:* 4-el Yagi perched atop the UN Building in New York. (Photo by Ken Arakawa, N2IEB/JS1DLC). *Lower right:* An impressive antenna farm silhouetted by the setting sun.

*Background:* Photo by Rob Schedinger of RJS Photography, Newington, Connecticut.

*Back cover:* Ant's eye view of a 54-foot tower, topped off with a TET tribander. (Photo by James Sharlow, W2ODH/6).



Copyright © 2000 by

The American Radio Relay League, Inc.

*Copyright secured under the Pan-American  
Convention*

International Copyright secured

This work is publication No. 15 of the Radio  
Amateur's Library, published by the ARRL. All  
rights reserved. No part of this work may be  
reproduced in any form except by written  
permission of the publisher. All rights of  
translation are reserved.

Printed in USA

*Quedan reservados todos los derechos*

19th Edition  
First Printing  
Antenna Book CD 2.0

ISBN: 0-87259-817-9

# Foreword

We are pleased to offer the 19th Edition of *The ARRL Antenna Book*. Since the first edition appeared in September 1939, each new volume has provided more and better information about the fascinating subjects of antennas, transmission lines and propagation. We've sold almost a million *Antenna Books* over the years to amateurs, professional engineers and technicians alike, making it one of the most successful books in the ARRL's extensive lineup of publications.

While the underlying fundamentals change only occasionally from edition to edition, the way the fundamentals are applied changes significantly. This can result in more highly optimized or specialized antennas that expand the amateur's ability to communicate. Many of the antennas described in this new edition benefit directly from advances in sophisticated computer modeling, for example.

This 19th Edition represents a great deal of effort on the part of its editor and many contributors. Nearly every chapter has been revised, including many that have been rewritten or extensively revised from the 18th Edition three years ago. We are fortunate to have had the expertise of the book's editor, Dean Straw, N6BV, and an impressive list of well-known and talented authors: Kurt Andress, K7NV, writing about towers and other antenna-support structures; L. B. Cebik, W4RNL, on Log Periodic Dipole Arrays; Rudy Severns, N6LF and Roy Lewallen, W7EL, on multielement phased arrays; and Frank Witt, AI1H, writing about broadband antennas.

In this 19th Edition we have also upgraded the most popular of the DOS-based programs included with the previous edition to more modern software standards. Editor Dean Straw, N6BV, put on his programming hat and developed two new Windows programs: *YW* (Yagi for Windows) and *TLW* (Transmission Line for Windows). Both incorporate new functionality and features that weren't possible in the DOS environment. *YW* and *TLW* work in the Microsoft Windows 95, 98 or 2000 programming environments. And we still include the innovative DOS *YT* (Yagi Terrain analysis) for analyzing the effects of your local terrain on the launch of HF signals into the ionosphere.

With publication of the 17th Edition of *The ARRL Antenna Book* in 1994, radio amateurs gained much-needed information about the kinds of elevation angles needed for worldwide HF communication. This 19th Edition includes even more of the detailed statistical analyses pioneered back in 1994, now covering 82 different locations around the world. You have information you need to design your own complete system properly—the angles to aim for from your part of the world, together with the effects of your own terrain.

We appreciate hearing from you, our readers, about any errors that may have crept into the book or about suggestions on how future editions might be made even more useful to you. A [form](#) for mailing your comments is included at the back of the book, or you can e-mail us at: [pubsfdbk@arrl.org](mailto:pubsfdbk@arrl.org).

David Sumner, K1ZZ  
Executive Vice President  
Newington, Connecticut  
August 2000

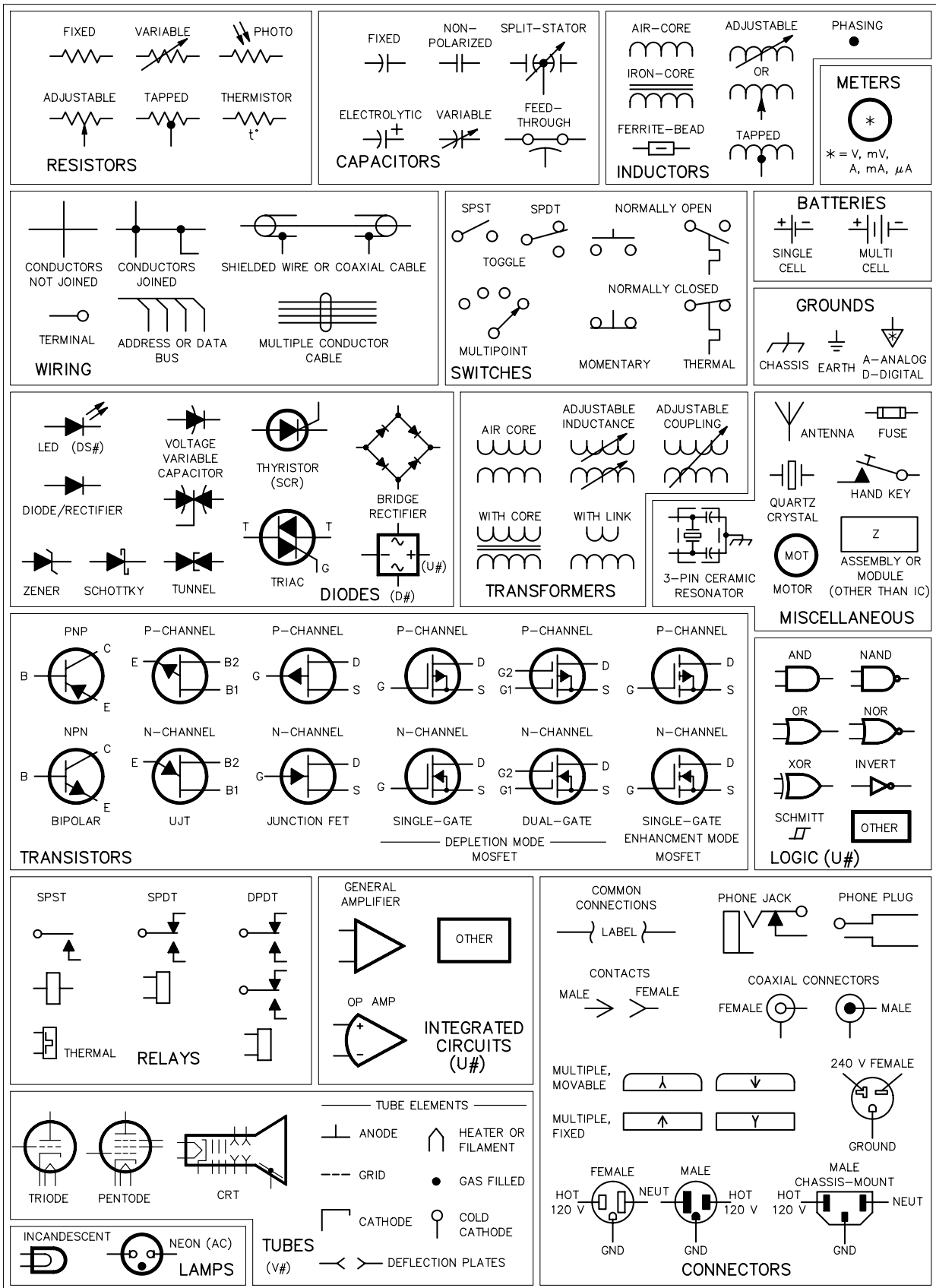
# Contents

1	Safety First
2	Antenna Fundamentals
3	The Effects of the Earth
4	Antenna System Planning and Practical Considerations
5	Loop Antennas
6	Low-Frequency Antennas
7	Multiband Antennas
8	Multielement Arrays
9	Broadband Antenna Matching
10	Log Periodic Arrays
11	HF Yagi Arrays
12	Quad Arrays
13	Long Wire and Traveling Wave Antennas
14	Direction Finding Antennas
15	Portable Antennas

Continued on [next page](#).

Continued from [previous page](#).

16	Mobile and Maritime Antennas
17	Repeater Antenna Systems
18	VHF and UHF Antenna Systems
19	Antenna Systems for Space Communications
20	Antenna Materials and Accessories
21	Antenna Products Suppliers
22	Antenna Supports
23	Radio Wave Propagation
24	Transmission Lines
25	Coupling the Transmitter to the Line
26	Coupling the Line to the Antenna
27	Antenna and Transmission-Line Measurements
28	Smith Chart Calculations
A-1	Appendix





# About the ARRL

The seed for Amateur Radio was planted in the 1890s, when Guglielmo Marconi began his experiments in wireless telegraphy. Soon he was joined by dozens, then hundreds, of others who were enthusiastic about sending and receiving messages through the air—some with a commercial interest, but others solely out of a love for this new communications medium. The United States government began licensing Amateur Radio operators in 1912.

By 1914, there were thousands of Amateur Radio operators—hams—in the United States. Hiram Percy Maxim, a leading Hartford, Connecticut, inventor and industrialist saw the need for an organization to band together this fledgling group of radio experimenters. In May 1914 he founded the American Radio Relay League (ARRL) to meet that need.

Today ARRL, with approximately 170,000 members, is the largest organization of radio amateurs in the United States. The ARRL is a not-for-profit organization that:

- promotes interest in Amateur Radio communications and experimentation
- represents US radio amateurs in legislative matters, and
- maintains fraternalism and a high standard of conduct among Amateur Radio operators.

At ARRL headquarters in the Hartford suburb of Newington, the staff helps serve the needs of members. ARRL is also International Secretariat for the International Amateur Radio Union, which is made up of similar societies in 150 countries around the world.

ARRL publishes the monthly journal *QST*, as well as newsletters and many publications covering all aspects of Amateur Radio. Its headquarters station, W1AW, transmits bulletins of interest to radio amateurs and Morse code practice sessions. The ARRL also coordinates an extensive field organization, which includes volunteers who provide technical information for radio amateurs and public-service activities. In addition, ARRL represents US amateurs with the Federal Communications Commission and other government agencies in the US and abroad.

Membership in ARRL means much more than receiving *QST* each month. In addition to the services already described, ARRL offers membership services on a personal level, such as the ARRL Volunteer Examiner Coordinator Program and a QSL bureau.

Full ARRL membership (available only to licensed radio amateurs) gives you a voice in how the affairs of the organization are governed. ARRL policy is set by a Board of Directors (one from each of 15 Divisions). Each year, one-third of the ARRL Board of Directors stands for election by the full members they represent. The day-to-day operation of ARRL HQ is managed by an Executive Vice President and a Chief Financial Officer.

No matter what aspect of Amateur Radio attracts you, ARRL membership is relevant and important. There would be no Amateur Radio as we know it today were it not for the ARRL. We would be happy to welcome you as a member! (An Amateur Radio license is not required for Associate Membership.) For more information about ARRL and answers to any questions you may have about Amateur Radio, write or call:

ARRL—The national association for Amateur Radio  
225 Main Street  
Newington CT 06111-1494  
Voice: 860-594-0200  
Fax: 860-594-0259  
E-mail: [hq@arrl.org](mailto:hq@arrl.org)  
Internet: [www.arrl.org/](http://www.arrl.org/)

Prospective new amateurs call (toll-free):

**800-32-NEW HAM** (800-326-3942)

You can also contact us via e-mail at [newham@arrl.org](mailto:newham@arrl.org)  
or check out *ARRLWeb* at <http://www.arrl.org/>

# FEEDBACK

Please use this form to give us your comments on this book and what you'd like to see in future editions, or e-mail us at [pubsfbk@arrl.org](mailto:pubsfbk@arrl.org) (publications feedback). If you use e-mail, please include your name, call, e-mail address and the book title, edition and printing in the body of your message. Also indicate whether or not you are an ARRL member.

Where did you purchase this book?

From ARRL directly     From an ARRL dealer

Is there a dealer who carries ARRL publications within:

5 miles     15 miles     30 miles    of your location?     Not sure.

License class:

Novice     Technician     Technician with code     General     Advanced     Amateur Extra

Name \_\_\_\_\_ ARRL member?  Yes  No  
\_\_\_\_\_ Call Sign \_\_\_\_\_

Daytime Phone (    ) \_\_\_\_\_ Age \_\_\_\_\_

Address \_\_\_\_\_

City, State/Province, ZIP/Postal Code \_\_\_\_\_ E-mail: \_\_\_\_\_

If licensed, how long? \_\_\_\_\_

Other hobbies \_\_\_\_\_

Occupation \_\_\_\_\_

For ARRL use only	ANT BK
Edition	19 20 21 22 23 24 25 26
Printing	1 2 3 4 5 6 7 8 9 10 11 12

From \_\_\_\_\_  
\_\_\_\_\_  
\_\_\_\_\_

Please affix  
postage. Post  
Office will not  
deliver without  
postage.

EDITOR, ARRL ANTENNA BOOK  
ARRL—THE NATIONAL ASSOCIATION FOR  
AMATEUR RADIO  
225 MAIN STREET  
NEWINGTON CT 06111-1494

----- please fold and tape -----

# Safety First

Safety begins with your attitude. If you make it a habit to plan your work carefully and to consider the safety aspects of a project before you begin the work, you will be much safer than “Careless Carl,” who just jumps in, proceeding in a haphazard manner. Learn to have a positive attitude about safety. Think about the dangers involved with a job before you begin the work. Don’t be the one to say, “I didn’t think it could happen to me.”

Having a good attitude about safety isn’t enough, however. You must be knowledgeable about common safety guidelines and follow them faithfully. Safety guidelines can’t possibly cover all the situations you might face, but if you approach a task with a measure of “common sense,” you should be able to work safely.

This chapter offers some safety guidelines and protective measures for you and your Amateur Radio station. You should not consider it to be an all-inclusive discussion of safety practices, though. Safety considerations will affect your choice of materials and assembly procedures when building an antenna. Other chapters of this book will offer further suggestions on safe construction practices. For example, [Chapter 22](#) includes some very important advice on a tower installation.

## PUTTING UP SIMPLE WIRE ANTENNAS

No matter what type of antenna you choose to erect, you should remember a few key points about safety. If you

are using a slingshot or bow and arrow to get a line over a tree, make sure you keep everyone away from the “downrange” area. Hitting one of your helpers with a rock or fishing sinker is considered not nice, and could end up causing a serious injury.

Make sure the ends of the antenna are high enough to be out of reach of passers-by. Even when you are transmitting with low power there may be enough voltage at the ends of your antenna to give someone nasty “RF burns.” If you have a vertical antenna with its base at ground level, build a wooden safety fence around it at least 4 feet away from it. Do not use metal fence, as this will interfere with the proper operation of the antenna. Be especially certain that your antenna is not close to any power wires. That is the only way you can be sure it won’t come in contact with them!

Antenna work often requires that one person climb up on a tower, into a tree or onto the roof of a house. Never work alone! Work slowly, thinking out each move before you make it. The person on the ladder, tower, tree or rooftop should wear a safety belt, and keep it securely anchored. It is helpful (and safe!) to tie strings or lightweight ropes to all tools. If your tools are tied on, you’ll save time getting them back if you drop them, and you’ll greatly reduce the risk of injuring a helper on the ground. (There are more safety tips for climbing and working on towers later in this chapter. Those tips apply to any work that you must do above the ground to install even the simplest antenna.)

## Tower Safety

Working on towers and antennas is dangerous, and possibly fatal, if you do not know what you are doing. Your tower and antenna can cause serious property damage and personal injury if any part of the installation should fail. Always use the highest quality materials in your system. Follow the manufacturer’s specifications, paying close attention to base pier and guying details. Do not overload the tower. If you have any doubts about your ability to work on your tower and antennas safely, contact another amateur with experience in this area or seek professional assistance.

[Chapter 22](#) provides more detailed guidelines for

constructing a tower base and putting up a tower. It also explains how to properly attach guy wires and install guy anchors in the ground. These are extremely important parts of a tower installation, and you should not take shortcuts or use second-rate materials. Otherwise the strength and safety of your entire antenna system may be compromised.

Any mechanical job is easier if you have the right tools. Tower work is no exception. In addition to a good assortment of wrenches, screwdrivers and pliers, you will need some specialized tools to work safely and efficiently on a tower. You may already own some of these tools. Others may be

purchased or borrowed. Don't start a job until you have assembled all of the necessary tools. Shortcuts or improvised tools can be fatal if you gamble and lose at 70 feet in the air. The following sections describe in detail the tools you will need to work safely on a tower.

## CLOTHING

The clothing you wear when working on towers and antennas should be selected for maximum comfort and safety. Wear clothing that will keep you warm, yet allow complete freedom of movement. Long denim pants and a long-sleeve shirt will protect you from scrapes and cuts. (A pull-on shirt, like a sweat shirt with no openings or buttons to snag on tower parts, is best.) Wear work shoes with heavy soles, or better yet, with steel shanks (steel inserts in the soles), to give your feet the support they need to stand on a narrow tower rung.

Gloves are necessary for both the tower climber and all ground-crew members. Good quality leather gloves will protect hands from injury and keep them warm. They also offer protection and a better grip when you are handling rope. In cooler weather, a pair of gloves with light insulation will help keep your hands warm. The insulation should not be so bulky as to inhibit movement, however.

Ground-crew members should have hard hats for protection in case something falls from the tower. It is not uncommon for the tower climber to drop tools and hardware. A wrench dropped from 100 feet will bury itself several inches in soft ground; imagine what it might do to an unprotected skull.

## SAFETY BELT AND CLIMBING ACCESSORIES

Any amateur with a tower must own a high-quality safety belt, such as the one shown in **Fig 1**. *Do not attempt* to climb a tower, even a short distance, without a belt. The climbing belt is more than just a safety device for the experienced climber. It is a tool to free up both hands for work. The belt allows the climber to lean back away from the tower to reach bolts or connections. It also provides a solid surface to lean against to exert greater force when hoisting antennas into place.

A climber must trust his life to his safety belt. For this reason, nothing less than a professional quality, commercially made, tested and approved safety belt is acceptable. Check the suppliers' list in [Chapter 21](#) and ads in *QST* for suppliers of climbing belts and accessories. Examine your belt for defects before each use. If the belt or lanyard (tower strap) are cracked, frayed or worn in any way, destroy the damaged piece and replace it with a new one. You should never have to wonder if your belt will hold.

Along with your climbing belt, you should seriously consider purchasing some climbing accessories. A canvas bucket is a great help for carrying tools and hardware up the tower. Two buckets, a large one for carrying tools and a smaller one for hardware, make it easier to find things when needed. A few extra snap hooks like those on the ends of your belt lanyard are useful for attaching tool bags and



**Fig 1**—Bill Lowry, W1VV, uses a good quality safety belt, a requirement for working on a tower. The belt should contain large steel loops for the strap snaps. Leather loops at the rear of the belt are handy for holding tools. (Photo by K1WA)

equipment to the tower at convenient spots. These hooks are better than using rope and tying knots because in many cases they can be hooked and unhooked with one hand.

*Gorilla hooks*, shown in **Fig 2**, are especially useful for ascending and descending the tower. They attach to the belt and are hooked to the tower on alternating rungs as the climber progresses. With these hooks, the climber is secured to the tower at all times. Gorilla hooks were specially designed for amateur climbers by Ron Williams, W9JVF, 1408 W Edgewood, Indianapolis, IN 46217-3618.

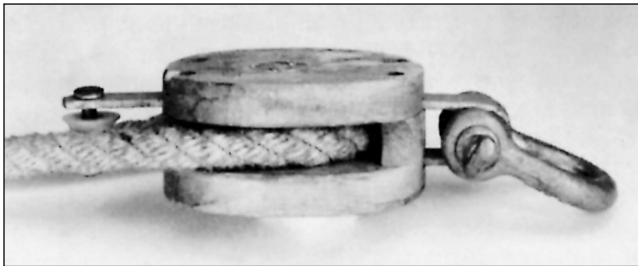
## Rope and Pulley

Every amateur who owns a tower should also own a good quality rope at least twice as long as the tower height. The rope is essential for safely erecting towers and installing antennas and cables. For most installations, a good quality 1/2-inch diameter manila hemp rope will do the job, although a thicker rope is stronger and may be easier to handle. Some types of polypropylene rope are acceptable also; check the manufacturer's strength ratings. Nylon rope is not recommended because it tends to stretch and cannot be securely knotted without difficulty.

Check your rope before each use for tearing or chafing. Do not attempt to use damaged rope; if it breaks with a tower



**Fig 2—Gorilla hooks are designed to keep the climber attached to the tower at all times when ascending and descending.**



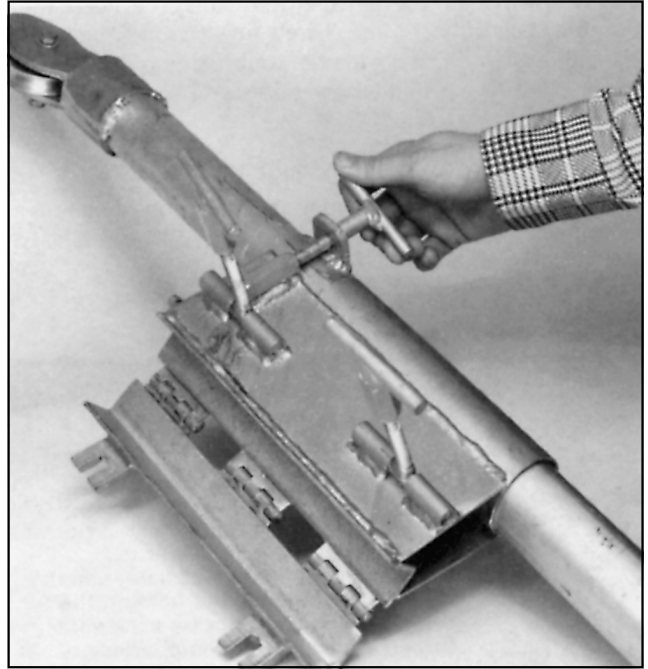
**Fig 3—A good quality rope and pulley are essential for anyone working on towers and antennas. This pulley is encased in wood so the rope cannot jump out of the pulley wheel and jam.**

section or antenna in mid-air, property damage and personal injury are likely results. If your rope should get wet, let it air dry thoroughly before putting it away.

Another very worthwhile purchase is a pulley like the one shown in **Fig 3**. Use the right size pulley for your rope. Be sure that the pulley you purchase will not jam or bind as the rope passes through it.

### THE GIN POLE

A gin pole, like the one shown in **Fig 4**, is a handy device for working with tower sections and masts. This gin pole is designed to clamp onto one leg of Rohn No. 25 or 45 tower. The tubing, which is about 12 feet long, has a pulley on one end. The rope is routed through the tubing and over the pulley. When the gin pole is attached to the tower and the tubing extended into place, the rope may be used to haul tower sections or the mast into place. **Fig 5** shows the basic process. A gin pole can be expensive for an individual to buy, especially for a one-time tower installation. Some radio clubs own a gin pole for use by their members. Stores that sell tower sections to amateurs and commercial customers frequently will rent a gin pole to erect the tower. If you attempt to make your own gin pole, use materials heavy enough for the job. Provide a means for securely clamping the pole to the tower. There are many cases on record where homemade gin poles have failed, sending tower sections crashing down amidst the ground crew.



**Fig 4—A gin pole is a mechanical device that can be clamped to a tower leg to aid in the assembly of sections as well as the installation of the mast. The aluminum tubing extends through the clamp and may be slipped into position before the tubing clamp is tightened. A rope should be routed through the tubing and over the pulley mounted at the top.**



**Fig 5—The assembly of tower sections is made simple when a gin pole is used to lift each one into position. Note that the safety belts of both climbers are fastened below the pole, thereby preventing the strap from slipping over the top section. (Photo by K1WA)**

When you use a gin pole, make every effort to keep the load as vertical as possible. Although gin poles are strong, you are asking for trouble if you apply too much lateral force.

## INSTALLING ANTENNAS ON THE TOWER

All antenna installations are different in some respects. Therefore, thorough planning is the most important first step in installing any antenna. At the beginning, before anyone climbs the tower, the whole process should be thought through. The procedure should be discussed to be sure each crew member understands what is to be done. Plan how to work out all bugs. Consider what tools and parts must be assembled and what items must be taken up the tower. Extra trips up and down the tower can be avoided by using forethought.

Getting ready to raise a beam requires planning. Done properly, the actual work of getting the antenna into position can be accomplished quite easily with only one person at the top of the tower. The trick is to let the ground crew do all the work and leave the person on the tower free to guide the antenna into position.

Before the antenna can be hoisted into position, the tower and the area around it must be prepared. The ground crew should clear the area around the base while someone climbs the tower to remove any wire antennas or other objects that might get in the way. The first person to climb the tower should also rig the rope and pulley that will be used to raise the antenna. The time to prepare the tower is before the antenna leaves the ground, not after it becomes hopelessly entwined with your 3.5-MHz dipole.

## SOME TOWER CLIMBING TIPS

The following tower climbing safety tips were compiled by Tom Willeford, N8ETU. The most important safety factor in any kind of hazardous endeavor is the right attitude. Safety is important and worthy of careful consideration and implementation. The right attitude toward safety is a requirement for tower climbers. Lip service won't do, however; safety must be practiced.

The safe ham's safety attitude is simple: *Don't take any unnecessary chances.* There are no exceptions to this plain and simple rule. It is the first rule of safety and, of course, of climbing. The second rule is equally simple: *Don't be afraid to terminate an activity* (climbing, in this case) at any time if things don't seem to be going well.

Take time to plan your climb; this time is never wasted, and it's the first building block of safety. Talk the climb over with friends who will be helping you. Select the date and alternative dates to do the work. Choose someone to be responsible for all activities on the ground and for all communication with the climbers. Study the structure to be climbed and choose the best route to your objective. Plan emergency ascent and descent paths and methods.

Make a list of emergency phone numbers to keep by your phone, even though they may never be used. Develop a plan for rescuing climbers from the structure, should that become necessary.

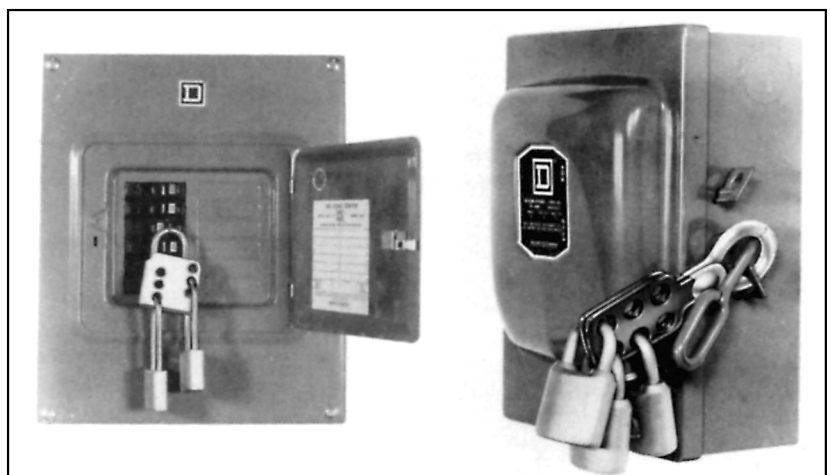
Give careful thought to how much time you will need to complete the project. Allow enough time to go up, do the work, and then climb down during daylight hours. Include time for resting during the climb and for completing the work in a quality fashion. Remember that the temperature changes fast as the sun goes down. Climbing up or down a tower with cold hands and feet is very difficult—and dangerous.

Give careful consideration to the weather, and climb only in good weather. Investigate wind conditions, the temperature, and the weather forecast. The weather can change quickly, so if you're climbing a really tall tower, it may be a good idea to have a weather alert radio handy during the climb. *Never* climb a wet tower.

The person who is going to do the climbing should be the one to disconnect and tag all sources of power to the structure. All switches or circuit breakers should be labeled clearly with DO NOT TOUCH instructions. Use locks on any switches designed to accept them. (See Fig 6.) Only the climber should reconnect power sources.

An important part of the climbing plan is to review notes on the present installation and any previous work. It's a good idea to keep a notebook, listing every bolt and nut size on your tower/antenna installation. Then, when you have to go up to make repairs, you'll be able to take the minimum number of tools with you to do the job. If you take too many tools up the tower, there is a much greater chance of dropping something, risking injury to the ground crew and possibly damaging the tool.

**Fig 6—If the switch box feeding power to equipment on your tower is equipped with a lock-out hole, use it. With a lock through the hole on the box, the power cannot be accidentally turned back on. (Photos courtesy of American ED CO®, at left, and Osborn Mfg Corp, at right.)**



It is also a good idea to review the instruction sheets and take them with you. In other words, plan carefully what you are going to do, and what you'll need to do it efficiently and safely.

It's better to use a rope and pulley to hoist tools. Climbing is hard work and there's no sense making it more difficult by carrying a big load of tools. Always rig the pulley and rope so the ground crew raises and lowers tools and equipment.

### Climbing Equipment

Equipment is another important safety consideration. By equipment, we don't just mean tools. We mean safety equipment. Safety equipment should be selected and cared for as if your life depends on it—because it does!

The list of safety equipment essential to a safe climb and safe work on the tower should include:

- 1) A first class safety belt,
- 2) Safety glasses,
- 3) Hard hat,
- 4) Long-sleeved, pull-over shirt with no buttons or openings to snag (long sleeves are especially important for climbing wooden poles),
- 5) Long pants without cuffs,
- 6) Firm, comfortable, steel-shank shoes with no-slip soles and well-defined heels, and
- 7) Gloves that won't restrict finger movement (insulated gloves if you **MUST** work in cold weather).

Your safety belt should be approved for use on the structure you are climbing. Different structures may require different types of safety hooks or straps. The belt should be light weight, but strength should not be sacrificed to save weight. It should fit you comfortably. All moving parts, such as snap hooks, should work freely. You should inspect safety belts and harnesses carefully and thoroughly before each climb, paying particular attention to stitching, rivets and weight-bearing mechanical parts.

Support belt hooks should always be hooked to the D rings in an outward configuration. That is, the opening part of the hook should face away from the tower when engaged in the D rings (see **Fig 7**). Hooks engaged this way are easier to unhook deliberately but won't get squeezed open by a part of the tower or engage and snag a part of the tower while you are climbing. The engagement of these hooks should always be checked visually. A snapping hook makes the same sound whether it's engaged or not. Never check by sound—look to be sure the hook is engaged properly before trusting it.

Remember that the D rings on the safety belt are for support hooks *only*. No tools or lines should be attached to these hooks. Such tools or lines may prevent the proper engagement of support belt hooks, or they may foul the hooks. At best, they could prevent the release of the hooks in an emergency. No one should have to disconnect a support hook to get a tool and then have to reconnect the support hook before beginning to work again. That's foolish.

Equipment you purchase new is best. Homemade belts



**Fig 7—Mark Wilson, K1RO, shows the proper way to attach a safety hook, with the hook opening facing away from the tower. That way the hook can't be accidentally released by pressing it against a tower leg.**

or home-spliced lines are dangerous. Used belts may have worn or defective stitching, or other faulty components. Be careful of so-called “bargains” that could cost you your life.

Straps, lanyards and lines should be as short as possible. Remember, in general knots reduce the load strength of a line by approximately 50%.

Before actually climbing, check the structure visually. Review the route. Check for obstacles, both natural (like wasp's nests) and man-made. Check the structure supports and add more if necessary. Guy wires can be obstacles to the climb, but it's better to have too many supports than not enough. Check your safety belt, support belts and hooks at the base of the tower. Really test them before you need them. Never leave the ground without a safety belt—even 5 or 10 feet. After all of this, the climb will be a “cake walk” if you are careful.

Climb slowly and surely. Don't overreach or overstep. Patience and watchfulness is rewarded with good hand and foot holds. Take a lesson from rock climbers. Hook on to the tower and rest periodically during the climb. Don't try to rest by wedging an arm or leg in some joint; to rest, hook on. Rests provide an opportunity to review the remainder of the route and to make sure that your safety equipment feels good and is working properly. Rest periods also help you conserve a margin of energy in case of difficulty.

Finally, keep in mind that the most dangerous part of working on a tower occurs when you are actually climbing. Your safety equipment is not hooked up at this time, so be extra careful during the ascent or descent.



You must climb the tower to install or work on an antenna. Nevertheless, any work that can be done on the ground should be done there. If you can do any assembly or make any adjustments on the ground, that's where you should do the work! The less time you have to spend on the tower, the better off you'll be.

When you arrive at the work area, hook on to the tower and review what you have to do. Determine the best position to do the work from, disconnect your safety strap and move to that position. Then reconnect your safety strap at a safe spot, away from joints and other obstacles. If you must move around an obstacle, try to do it while hooked on to the tower. Find a comfortable position and go to work. Don't overreach—move to the work.

Use the right tool for the task. If you don't have it, have the ground crew haul it up. Be patient. Lower tools, don't drop them, when you are finished with them. Dropped tools can bounce and cause injury or damage, or can be broken or lost. It's a good idea to tie a piece of string or light rope to the tools, and to tie the other end to the tower or some other point so if you do drop a tool, it won't fall all the way to the ground. Don't tie tools to the D ring or your safety belt, however!

Beware of situations where an antenna may be off balance. It's hard to obtain the extra leverage needed to handle even a small beam when you are holding it far from the balance point. Leverage can apply to the climber as well as the device being levered. Many slips and skinned knuckles result from such situations. A severely injured hand or finger can be a real problem to a climber.

Before descending, be sure to check all connections and the tightness of all the bolts and nuts that you have worked with. Have the ground crew use the rope and pulley to lower your tools. Lighten your load as much as possible. Remember, you're more tired coming down than going up. While still hooked on, wiggle your toes and move a little to get your senses working again. Check your downward route and begin to descend slowly and even more surely than you went up. Rest is even more important during the descent.

The ground captain is the director of all activities on the ground, and should be the only one to communicate with a person on a tower. Hand-held transceivers can be very helpful for this communication, but no one else should transmit to the workers on the tower. Even minor confusion or misunderstanding about a move to be made could be very dangerous.

"Antenna parties" can be lots of fun, but the joking and fooling around should wait until the job is done and everyone is down safely. Save the celebrating until after the work is completed, even for the ground crew.

These are just a few ideas on tower climbing safety; no list can include everything that you might run into. Check [Chapter 22](#) for additional ideas. *Just remember—you can't be too careful when climbing.* Keep safety in mind while doing antenna work, and help ensure that after you have fallen *for* ham radio, you don't fall *from* ham radio.

## THE TOWER SHIELD

A tower can be legally classified as an "attractive nuisance" that could cause injuries. You should take some precautions to ensure that "unauthorized climbers" can't get hurt on your tower. This tower shield was originally described by Baker Springfield, W4HYY, and Richard Ely, WA4VHM, in September 1976 *QST*, and should eliminate the worry.

Generally, the attractive-nuisance doctrine applies to your responsibility to trespassers on your property. (The law is much stricter with regard to your responsibility to an invited guest.) You should expect your tower to attract children, whether they are already technically trespassing or whether the tower itself lures them onto your property. A tower is dangerous to children, especially because of their inability to appreciate danger. (What child could resist trying to climb a tower once they see one?) Because of this danger, you have a legal duty to exercise reasonable care to eliminate the danger or otherwise protect children against the perils of the attraction.

The tower shield is composed simply of panels that enclose the tower and make climbing practically impossible. These panels are 5 feet in height and are wide enough to fit snugly between the tower legs and flat against the rungs. A height of 5 feet is sufficient in almost every case. The panels are constructed from 18-gauge galvanized sheet metal obtained and cut to proper dimensions from a local sheet-metal shop. A lighter gauge could probably be used, but the extra physical weight of the heavier gauge is an advantage if no additional means of securing the panels to the tower rungs are used. The three types of metals used for the components of the shield are supposedly rust proof and nonreactive. The panels are galvanized sheet steel, the brackets aluminum, and the screws and nuts are brass. For a triangular tower, the shield consists of three panels, one for each of the three sides, supported by two brackets. Construct these brackets from 6-inch pieces of thin aluminum angle stock. Bolt two of the pieces together to form a Z bracket (see [Figs 8, 9](#) and [10](#)). The Z brackets are bolted together with binding head brass machine screws.

Lay the panels flat for measuring, marking and drilling. First measure from the top of the upper mounting rung on the tower to the top of the bottom rung. (Mounting rungs are selected to position the panel on the tower.) Then mark this distance on the panels. Use the same size brass screws

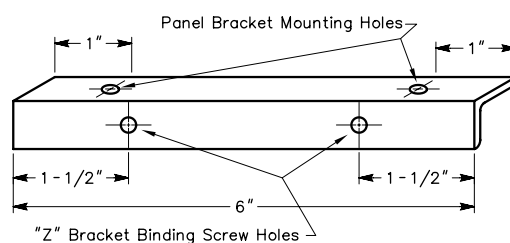
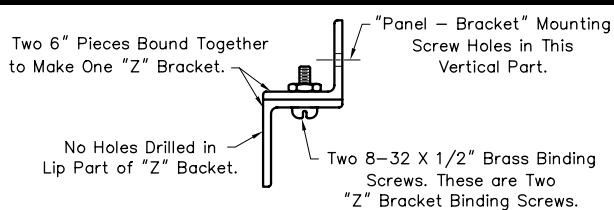
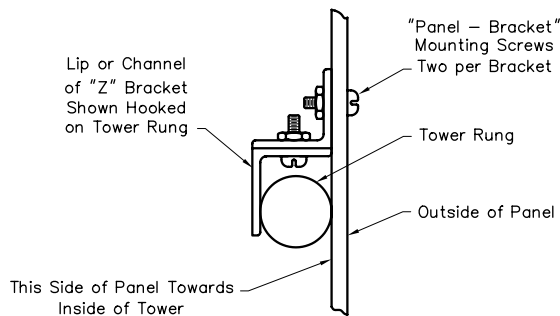


Fig 8—Z-bracket component pieces.



**Fig 9—Assembly of the Z bracket.**

**PANEL WITH MOUNTED "Z" BRACKET**

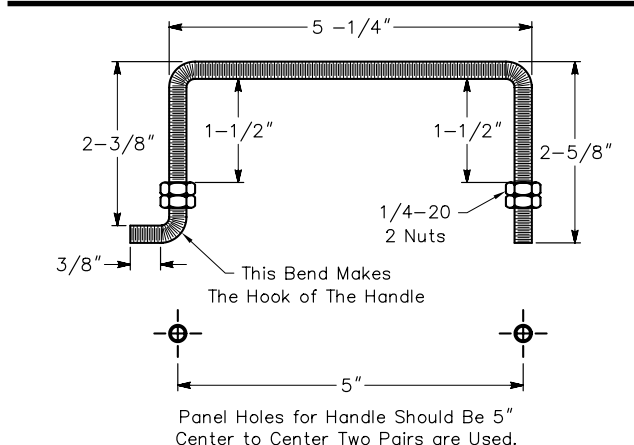


**Fig 10—Installation of the shield on a tower rung.**

and nuts throughout the shield. Bolt the top vertical portion of each Z bracket to the panel. Drill the mounting-screw holes about 1 inch from the end of the Z brackets so there is an offset clearance between the Z-bracket binding-screw holes and the panel-bracket mounting-screw holes. Drill holes in each panel to match the Z-bracket holes.

The panels are held on the tower by their own weight. They are not easy to grasp because they fit snugly between the tower legs. If you feel a need for added safety against deliberate removal of the panels, this can be accomplished by means of tie wires. Drill a small hole in the panel just above, just below, and in the center of each Z bracket. Run a piece of heavy galvanized wire through the top hole, around the Z bracket, and then back through the hole just below the Z bracket. Twist together the two ends of the wire. One tie wire should be sufficient for each panel, but use two if desired.

The completed panels are rather bulky and difficult to handle. A feature that is useful if the panels have to be removed often for tower climbing or accessibility is a pair of removable handles. The removable handles can be constructed from one threaded rod and eight nuts (see **Fig 11**). Drill two pair of handle holes in the panels a few inches below the top Z bracket and several inches above the bottom Z bracket. For panel placement or removal, you can hook the handles in these panel holes. The hook, on the top of the handle, fits into the top hole of each pair of the handle holes. The handle is optional, but for the effort required it certainly makes removal and replacement



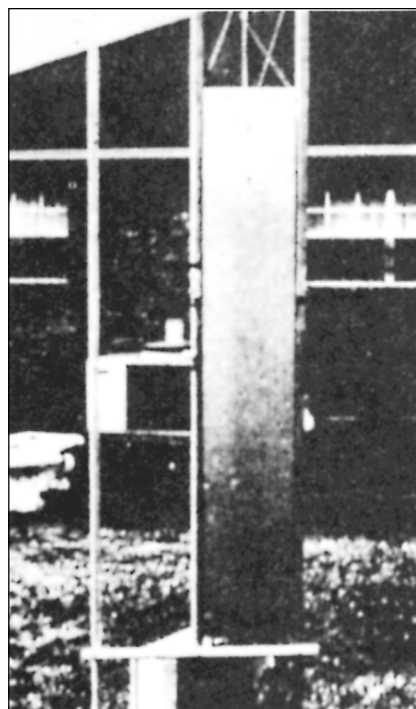
**Notes:**

1. Standard Rodstock 1/4"-20 X 36" was Used.
2. Two Pieces were Cut from Rod Stock. Each Approximately 10 7/8".
3. Make The Three Bends of The Rod in Vise.
4. Two Nuts 1/4-20 of The Same Threads as Rods. Jam or Lock Together. This Makes a Handle Stop.

**Fig 11—Removable handle construction.**

much safer and easier.

**Fig 12** shows the shield installed on a tower. This relatively simple device could prevent an accident.



**Fig 12—Installed tower shield. Note the holes for using the handles.**

# Electrical Safety

Although the RF, ac and dc voltages in most amateur stations pose a potentially grave threat to life and limb, common sense and knowledge of safety practices will help you avoid accidents. Building and operating an Amateur Radio station can be, and is for almost all amateurs, a perfectly safe pastime. However, carelessness can lead to severe injury, or even death. The ideas presented here are only guidelines; it would be impossible to cover all safety precautions. Remember, there is no substitute for common sense.

A fire extinguisher is a requirement for the well-equipped amateur station. The fire extinguisher should be of the carbon-dioxide type to be effective in electrical fires. Store it in an easy-to-reach spot and check it at recommended intervals.

Family members should know how to turn the power off in your station. They should also know how to apply artificial respiration. Many community groups offer courses on cardiopulmonary resuscitation (CPR).

## AC AND DC SAFETY

The primary wiring for your station should be controlled by one master switch, and other members of your household should know how to kill the power in an emergency. All equipment should be connected to a good ground. All wires carrying power around the station should be of the proper size for the current to be drawn and should be insulated for the voltage level involved. Bare wire, open-chassis construction and exposed connections are an invitation to accidents. Remember that high-current, low-voltage power sources are just as dangerous as high-voltage, low-current sources. Possibly the most-dangerous voltage source in your station is the 120-V primary supply; it is a hazard often overlooked because it is a part of everyday life. Respect even the lowliest power supply in your station.

Whenever possible, kill the power and unplug equipment before working on it. Discharge capacitors with an insulated screwdriver; don't assume the bleeder resistors are 100% reliable. In a power amplifier, always short the tube plate cap to ground just to be sure the supply is discharged. If you must work on live equipment, keep one hand in your pocket. Avoid bodily contact with any grounded object to prevent your body from becoming the return path from a voltage source to ground. Use insulated tools for adjusting or moving any circuitry. Never work alone. Have someone else present; it could save your life in an emergency.

## National Electrical Code

The National Electrical Code® is a comprehensive document that details safety requirements for all types of electrical installations. In addition to setting safety standards for house wiring and grounding, the Code also contains a section on Radio and Television Equipment — Article 810. Sections C and D specifically cover Amateur Transmitting and Receiving Stations. Highlights of the section concerning

Amateur Radio stations follow. If you are interested in learning more about electrical safety, you may purchase a copy of *The National Electrical Code* or *The National Electrical Code Handbook*, edited by Peter Schram, from the National Fire Protection Association, Batterymarch Park, Quincy, MA 02269.

Antenna installations are covered in some detail in the Code. It specifies minimum conductor sizes for different length wire antennas. For hard-drawn copper wire, the Code specifies #14 wire for open (unsupported) spans less than 150 feet, and #10 for longer spans. Copper-clad steel, bronze or other high-strength conductors may be #14 for spans less than 150 feet and #12 wire for longer runs. Lead-in conductors (for open-wire transmission line) should be at least as large as those specified for antennas.

The Code also says that antenna and lead-in conductors attached to buildings must be firmly mounted at least 3 inches clear of the surface of the building on nonabsorbent insulators. The only exception to this minimum distance is when the lead-in conductors are enclosed in a “permanently and effectively grounded” metallic shield. The exception covers coaxial cable.

According to the Code, lead-in conductors (except those covered by the exception) must enter a building through a rigid, noncombustible, nonabsorbent insulating tube or bushing, through an opening provided for the purpose that provides a clearance of at least 2 inches or through a drilled window pane. All lead-in conductors to transmitting equipment must be arranged so that accidental contact is difficult.

Transmitting stations are required to have a means of draining static charges from the antenna system. An antenna discharge unit (lightning arrester) must be installed on each lead-in conductor (except where the lead-in is protected by a continuous metallic shield that is permanently and effectively grounded, or the antenna is permanently and effectively grounded). An acceptable alternative to lightning arrester installation is a switch that connects the lead-in to ground when the transmitter is not in use.

Grounding conductors are described in detail in the Code. Grounding conductors may be made from copper, aluminum, copper-clad steel, bronze or similar erosion-resistant material. Insulation is not required. The “protective grounding conductor” (main conductor running to the ground rod) must be as large as the antenna lead-in, but not smaller than #10. The “operating grounding conductor” (to bond equipment chassis together) must be at least #14. Grounding conductors must be adequately supported and arranged so they are not easily damaged. They must run in as straight a line as practical between the mast or discharge unit and the ground rod.

The Code also includes some information on safety inside the station. All conductors inside the building must be at least 4 inches away from conductors of any lighting or signaling circuit except when they are separated from other

conductors by conduit or a nonconducting material. Transmitters must be enclosed in metal cabinets, and the cabinets must be grounded. All metal handles and controls accessible by the operator must be grounded. Access doors must be fitted with interlocks that will disconnect all potentials above 350 V when the door is opened.

### Ground

An effective ground system is necessary for every amateur station. The mission of the ground system is twofold. First, it reduces the possibility of electrical shock if something in a piece of equipment should fail and the chassis or cabinet becomes “hot.” If connected properly, three-wire electrical systems ground the chassis, but older amateur equipment may use the ungrounded two-wire system. A ground system to prevent shock hazards is generally referred to as “dc ground.”

The second job the ground system must perform is to provide a low-impedance path to ground for any stray RF current inside the station. Stray RF can cause equipment to malfunction and contributes to RFI problems. This low-impedance path is usually called “RF ground.” In most stations, dc ground and RF ground are provided by the same system.

The first step in building a ground system is to bond together the chassis of all equipment in your station. Ordinary hookup wire will do for a dc ground, but for a good RF ground you need a low-impedance conductor. Copper strap, sold as “flashing copper,” is excellent for this application, but it may be hard to find. Braid from coaxial cable is a popular choice; it is readily available, makes a low-impedance conductor, and is flexible.

Grounding straps can be run from equipment chassis to equipment chassis, but a more convenient approach is illustrated in Fig 13. In this installation, a 1/2-inch diameter copper water pipe runs the entire length of the operating bench. A thick braid (from discarded RG-8 cable) runs from each piece of equipment to a clamp on the pipe. Copper water pipe is available at most hardware stores and home centers. Alternatively, a strip of flashing copper may be run

along the rear of the operating bench.

After the equipment is bonded to a common ground bus, the ground bus must be wired to a good earth ground. This run should be made with a heavy conductor (braid is a popular choice, again) and should be as short and direct as possible. The earth ground usually takes one of two forms.

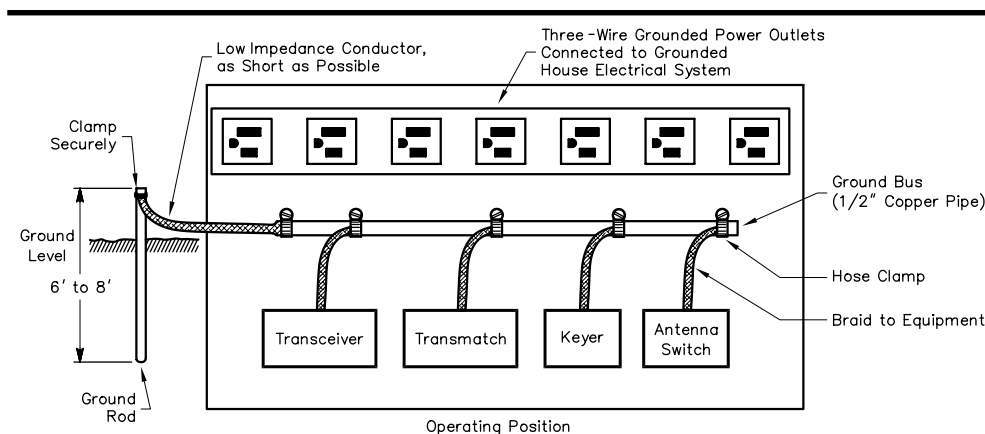
In most cases, the best approach is to drive one or more ground rods into the earth at the point where the conductor from the station ground bus leaves the house. The best ground rods to use are those available from an electrical supply house. These rods are 8 to 10 feet long and are made from steel with a heavy copper plating. Do not depend on shorter, thinly plated rods sold by some home electronics suppliers. These rods begin to rust almost immediately after they are driven into the soil, and they become worthless within a short time. Good ground rods, while more expensive initially, offer long-term protection.

If your soil is soft and contains few rocks, an acceptable alternative to “genuine” ground rods is 1/2-inch diameter copper water pipe. A 6- to 8-foot length of this material offers a good ground, but it may bend while being driven into the earth. Some people have recommended that you make a connection to a water line and run water down through the copper pipe so that it forces its own hole in the ground. There may be a problem with this method, however. When the ground dries, it may shrink away from the pipe and not make proper contact with the ground rod. This would provide a rather poor ground.

Once the ground rod is installed, clamp the conductor from the station ground bus to it with a clamp that can be tightened securely and will not rust. Copper-plated clamps made especially for this purpose are available from electrical supply houses, but a stainless-steel hose clamp will work too. Alternatively, drill several holes through the pipe and bolt the conductor in place. If a torch is available, solder the connection.

Another popular station ground is the cold water pipe system in the building. To take advantage of this ready made ground system, run a low-impedance conductor from the station ground bus to a convenient cold water pipe, preferably

**Fig 13—An effective station ground bonds the chassis of all equipment together with low-impedance conductors and ties into a good earth ground.**



somewhere near the point where the main water supply enters the house. Avoid hot water pipes; they do not run directly into the earth. The advent of PVC (plastic) plumbing makes it mandatory to inspect the cold water system from your intended ground connection to the main inlet. PVC is an excellent insulator, so any PVC pipe or fittings rule out your cold water system for use as a station ground.

For some installations, especially those located above the first floor, a conventional ground system such as that just described will make a fine dc ground but will not provide the necessary low-impedance path to ground for RF. The length of the conductor between the ground bus and the ultimate ground point becomes a problem. For example, the ground wire may be about  $\frac{1}{4} \lambda$  (or an odd multiple of  $\frac{1}{4} \lambda$ ) long on some amateur band. A  $\frac{1}{4} \lambda$  wire acts as an impedance inverter from one end to the other. Since the grounded end is at a very low impedance, the equipment end will be at a high impedance. The likely result is RF hot spots around the station while the transmitter is operating. A ground system like this may be worse than having no ground at all.

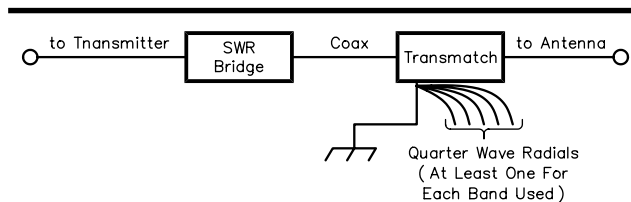
An alternative RF ground system is shown in **Fig 14**. Connect a system of  $\frac{1}{4} \lambda$  radials to the station ground bus. Install at least one radial for each band used. You should still be sure to make a connection to earth ground for the ac power wiring. Try this system if you have problems with RF in the shack. It may just solve a number of problems for you.

### Ground Noise

Noise in ground systems can affect sensitive radio equipment. It is usually related to one of three problems:

- 1) Insufficient ground conductor size,
- 2) Loose ground connections, or
- 3) Ground loops.

These matters are treated in precise scientific research



**Fig 14—Here is an alternative to earth ground if the station is located far from the ground point and RF in the station is a problem. Install at least one  $\frac{1}{4} \lambda$  radial for each band used.**

equipment and some industrial instruments by paying attention to certain rules. The ground conductor should be at least as large as the largest conductor in the primary power circuit. Ground conductors should provide a solid connection to both ground and to the equipment being grounded. Liberal use of lock washers and star washers is highly recommended. A loose ground connection is a tremendous source of noise, particularly in a sensitive receiving system.

Ground loops should be avoided at all costs. A short discussion of what a ground loop is and how to avoid them may lead you down the proper path. A ground loop is formed when more than one ground current is flowing in a single conductor. This commonly occurs when grounds are “daisy-chained” (series linked). The correct way to ground equipment is to bring all ground conductors out radially from a common point to either a good driven earth ground or to a cold water system.

Ground noise can affect transmitted as well as received signals. With the low audio levels required to drive amateur transmitters, and with the ever-increasing sensitivity of our receivers, correct grounding is critical.

## Lightning and EMP Protection

The National Fire Protection Association (NFPA) publishes a booklet called *Lightning Protection Code* (NFPA no. 78-1983) that should be of interest to radio amateurs. For information about obtaining a copy of this booklet, write to the National Fire Protection Association, Batterymarch Park, Quincy, MA 02269. Two paragraphs of particular interest to amateurs are presented below:

“3-26 Antennas. Radio and television masts of metal, located on a protected building, shall be bonded to the lightning protection system with a main size conductor and fittings.

“3-27 Lightning arresters, protectors or antenna discharge units shall be installed on electric and telephone service entrances and on radio and television antenna lead-ins.”

The best protection from lightning is to disconnect all antennas from equipment and disconnect the equipment from the power lines. Ground antenna feed lines to safely bleed off static buildup. Eliminate the possible paths for lightning

strokes. Rotator cables and other control cables from the antenna location should also be disconnected during severe electrical storms.

In some areas, the probability of lightning surges entering homes via the 120/240-V line may be high. Lightning produces both electrical and magnetic fields that vary with distance. These fields can be coupled into power lines and destroy electronic components in equipment that is miles from where the lightning occurred. Radio equipment can be protected from these surges to some extent by using transient-protective devices.

### ELECTROMAGNETIC PULSE AND THE RADIO AMATEUR

The following material is based on a 4-part *QST* article by Dennis Bodson, W4PWF, that appeared in the August through November 1986 issues of *QST* (see the [References](#) cited at the end of this chapter). The series was

condensed from the National Communications System report NCS TIB 85-10.

An equipment test program demonstrated that most Amateur Radio installations can be protected from lightning and electromagnetic pulse (EMP) transients with a basic protection scheme. Most of the equipment is not susceptible to damage when all external cabling is removed. You can duplicate this stand-alone configuration simply by unplugging the ac power cord from the outlet, disconnecting the antenna feed line at the rear of the radio, and isolating the radio gear from any other long metal conductors. Often it is not practical to completely disconnect the equipment whenever it is not being used. Also, there is the danger that a lightning strike several miles away could induce a large voltage transient on the power lines or antenna while the radio is in use. You can add two transient-protection devices to the interconnected system, however, that will also closely duplicate the safety of the stand-alone configuration.

The ac power line and antenna feed line are the two important points that should be outfitted with transient protection. This is the minimum basic protection scheme recommended for all Amateur Radio installations. (For fixed installations, consideration should also be given to the rotator connections—see **Fig 15.**) Hand-held radios equipped with a “rubber duck” require no protection at the antenna jack. If a larger antenna is used with the hand-held, however, a protection device should be installed.

### General Considerations

Because of the unpredictable energy content of a nearby lightning strike or other large transient, it is possible for a metal-oxide varistor (MOV) to be subjected to an energy surge in excess of its rated capabilities. This may result in

the destruction of the MOV and explosive rupture of the package. These fragments can cause damage to nearby components or operators and possibly ignite flammable material. Therefore, the MOV should be physically shielded.

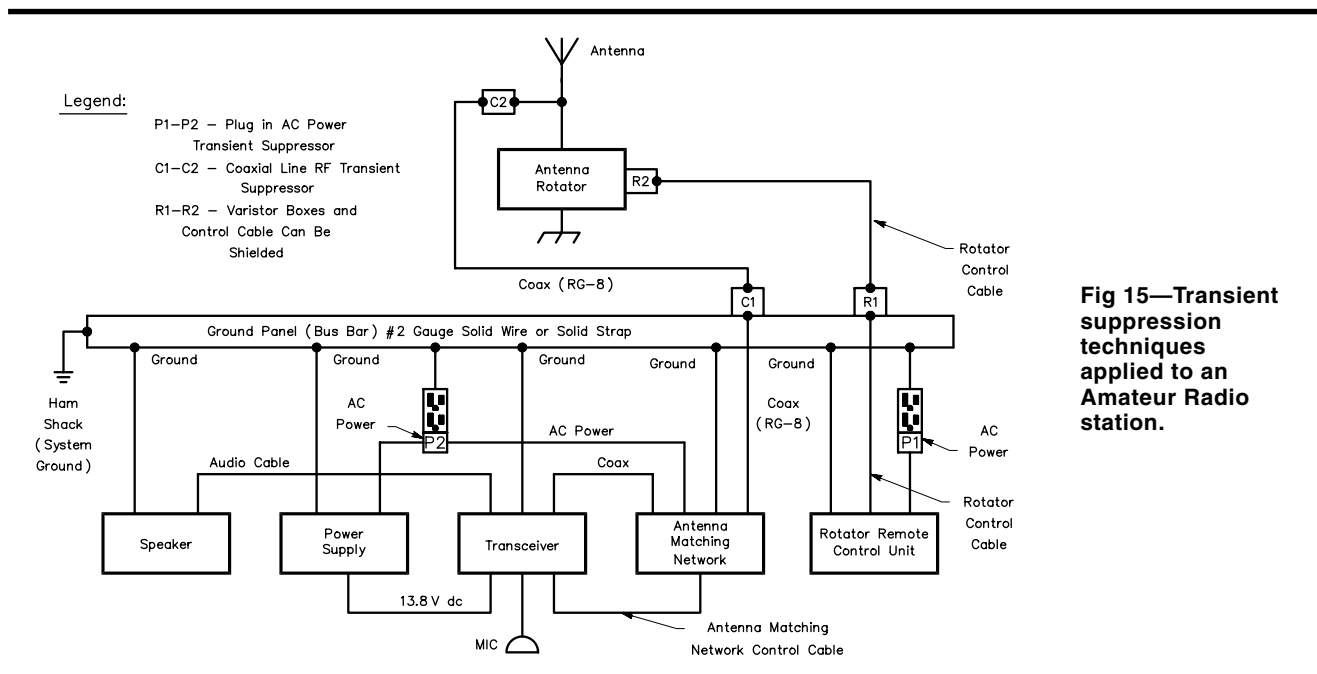
A proper ground system is a key factor in achieving protection from lightning and EMP transients. A low-impedance ground system should be installed to eliminate transient paths through radio equipment and to provide a good physical ground for the transient-suppression devices. A single-point ground system is recommended (see **Fig 16**). Inside the station, single-point grounding can be had by installing a ground panel or bus bar. All external conductors going to the radio equipment should enter and exit the station through this panel. Install all transient-suppression devices directly on the panel. Use the shortest length(s) possible of #6 solid wire to connect the radio equipment case(s) to the ground bus.

### AC Power-Line Protection

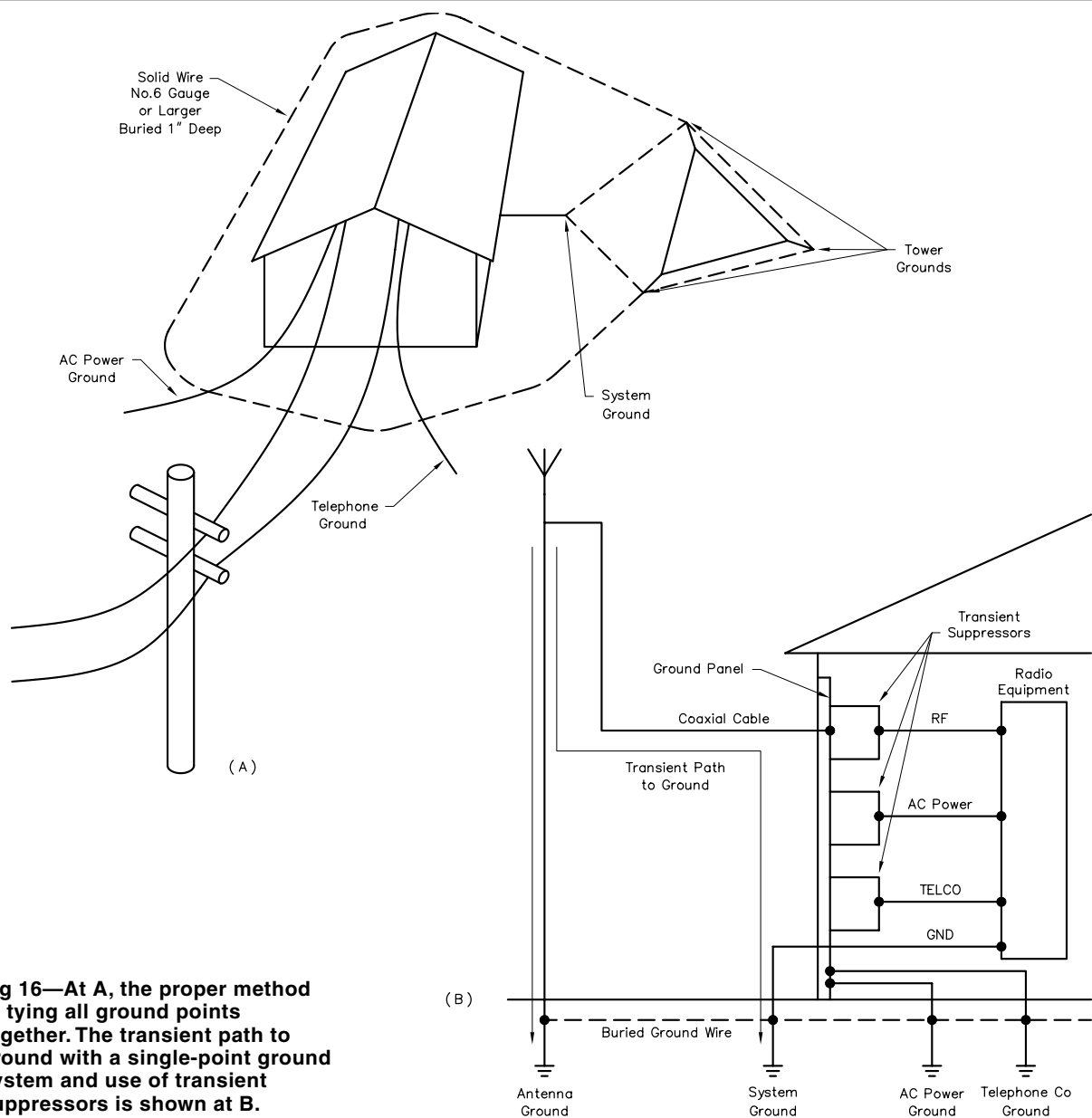
Tests have indicated that household electrical wiring inherently limits the maximum transient current that it will pass to approximately 120 A. Therefore, if possible, the amateur station should be installed away from the house ac entrance panel and breaker box to take advantage of these limiting effects.

AC power-line protection can be provided with easy-to-install, plug-in transient protectors. Ten such devices were tested for the article series in 1986. The plug-in-strip units are the best overall choice for a typical amateur installation. They provide the protection needed, they’re simple to install and can be easily moved to other operating locations with the equipment.

In their tests, NCS found that the model that provided transient paths to ground from the hot and neutral lines



**Fig 15—Transient suppression techniques applied to an Amateur Radio station.**



**Fig 16—At A, the proper method of tying all ground points together. The transient path to ground with a single-point ground system and use of transient suppressors is shown at B.**

(common mode) as well as the transient path between the hot and neutral lines (normal mode) performed best. The best model used three MOVs and a 3-electrode gas-discharge-tube arrester to provide fast operation and large power dissipation capabilities. This unit was tested repeatedly and operated without failure.

The flood of low-cost computers in the 1990s spawned a host of surge protection devices designed to limit transient voltage spikes coming from the ac line and also through the telephone line into a modem connected to a computer. Many of these devices are well-designed and can be relied upon to provide the protection they claim.

You can, however, easily find a variety of really low-cost bargain strips at flea markets and discount hardware

stores. A bargain-brand \$6 unit may prove to be a poor bargain indeed if it allows a spike to get through to damage your \$2000 computer or \$4000 transceiver.

You should be careful to find one that carries a sticker indicating that it meets Underwriters Laboratories safety standard UL 1449. This defines the minimum level of clamping voltage beyond which a surge protector will “fire” to protect the device connected to its output. The UL 1149 limit is 330 V ac. Prices for brand-name units from Tripp Lite, APC or Curtis vary from about \$30 to \$80, depending on how many ac sockets they have and the number of indicator lights and switched/unswitched sockets. A brand-name device is well worth the small additional cost over the bargain-basement units.

A transient suppressor requires a 3-wire outlet; the outlet should be tested to ensure all wires are properly connected. In older houses, an ac ground may have to be installed by a qualified electrician. The ac ground must be available for the plug-in transient suppressor to function properly. The ac ground of the receptacle should be attached to the station ground bus, and the plug-in receptacle should be installed on the ground panel behind the radio equipment.

### Emergency Power Generators

Emergency power generators provide two major transient-protection advantages. First, the station is disconnected from the commercial ac power system. This isolates the radio equipment from a major source of damaging transients. Second, tests have shown that the emergency power generator may not be susceptible to EMP transients.

When the radio equipment is plugged directly into the generator outlets, transient protection may not be needed. If an extension cord or household wiring is used, transient protection should be employed.

An emergency power generator should be wired into the household circuit only by a qualified electrician. When properly connected, a switch is used to disconnect the commercial ac power source from the house lines before the generator is connected to them. This keeps the generator output from feeding back into the commercial power system. If this is not done, death or injury to unsuspecting linemen can result.

### Feed-Line Protection

Coaxial cable is recommended for use as the transmission line because it provides a certain amount of transient surge protection for the equipment to which it is attached. The outer conductor shields the center conductor from the transient field. Also, the cable limits the maximum conducted transient voltage on the center by arcing the differential voltage from the center conductor to the grounded cable shield.

By providing a path to ground ahead of the radio equipment, the gear can be protected from the large currents impressed upon the antenna system by lightning and EMP. A single protection device installed at the radio antenna jack will protect the radio, but not the transmission line. To protect the transmission line, another transient protector must be installed between the antenna and the transmission line. (See Fig 15).

RF transient protection devices from several manufacturers were tested (see Table 1) using RG-8 cable equipped with UHF connectors. All of the devices shown can be installed in a coaxial transmission line. Recall that during the tests the RG-8 cable acted like a suppressor; damaging EMP energy arced from the center conductor to the cable shield when the voltage level approached 5.5 kV.

Low price and a low clamping-voltage rating must be considered in the selection of an RF transient-protection device. The lower cost devices have the higher clamping voltages, however, and the higher-cost devices have the lower clamping voltages. Because of this, medium-priced devices manufactured by Fischer Custom Communications were selected for testing. The Fischer Spikeguard Suppressors (\$55 price class) for coaxial lines can be made to order to operate at a specific clamping voltage. The Fischer devices satisfactorily suppressed the damaging transient pulses, passed the transmitter RF output power without interfering with the signal, and operated effectively over a wide frequency range.

Polyphaser Corporation devices are also effective in providing the necessary transient protection. The devices available limited the transmitter RF output power to 100 W or less, however. These units cost approximately \$83 each.

RF coaxial protectors should be mounted on the station ground bus bar. If the Fischer device is used, it should be attached to a grounded UHF receptacle that will serve as a hold-down bracket. This creates a conductive path between the outer shield of the protector and the bus bar. The Polyphaser device can be mounted directly to the bus bar with the bracket provided.

Attach the transceiver or antenna matching network to the grounded protector with a short (6 foot or less) piece of coaxial cable. Although the cable provides a ground path to the bus bar from the radio equipment, it is not a satisfactory transient-protection ground path for the transceiver. Another ground should be installed between the transceiver case and the ground bus using solid #6 wire. The coaxial cable shield should be grounded to the antenna tower leg at the tower base. Each tower leg should have an earth ground connection and be connected to the single-point ground system as shown in Fig 16.

**Table 1**  
**RF Coaxial-Line Protectors**

<i>Manufacturer</i>	<i>Device</i>	<i>Approximate Cost (US Dollars)</i>	<i>Measured High-Z Clamping Voltage (Volts)</i>
Fischer	FCC-250-300-UHF	55	393
Fischer	FCC-250-350-UHF	55	260
Fischer	FCC-250-150-UHF	55	220
Fischer	FCC-250-120-UHF	55	240
Fischer	FCC-450-120-UHF	55	120
Polyphaser	IS-NEMP	83	140
Polyphaser	IS-NEMP-1	83	150
Polyphaser	IS-NEMP-2	83	160

Note: The transmitter output power, frequency of operation, and transmission line SWR must be considered when selecting any of these devices.



## Antenna Rotators

Antenna rotators can be protected by plugging the control box into a protected ac power source and adding protection to the control lines to the antenna rotator. When the control lines are in a shielded cable, the shield must be grounded at both ends. MOVs of the proper size should be installed at both ends of the control cable. At the station end, terminate the control cable in a small metal box that is connected to the station ground bus. Attach MOVs from each conductor to ground inside the box. At the antenna end of the control cable, place the MOVs inside the rotator case or in a small metal box that is properly grounded.

For example, the Alliance HD73 antenna rotator uses a 6-conductor unshielded control cable with a maximum control voltage of 24.7 V dc. Select an MOV with a clamping voltage level 10% higher (27 V or more) so the MOV won't clamp the control signal to ground. If the control voltage is ac, be sure to convert the RMS voltage value to peak voltage when considering the clamping voltage level.

## Mobile Power Supply Protection

The mobile amateur station environment exposes radio equipment to other transient hazards in addition to those of lightning and EMP. Currents as high as 300 A are switched when starting the engine, and this can produce voltage spikes of over 200 V on the vehicle's electrical system. Lightning and EMP are not likely to impact the vehicle's electrical system as much as they would that of a fixed installation because the automobile chassis is not normally grounded. This would not be the case if the vehicle is inadvertently grounded; for example, when the vehicle is parked against a grounded metal conductor. The mobile radio system has two advantages over a fixed installation: Lightning is almost never a problem, and the vehicle battery is a natural surge suppressor.

Mobile radio equipment should be installed in a way that takes advantage of the protection provided by the battery. See

**Fig 17.** To do this, connect the positive power lead of the radio directly to the positive battery post, not to intermediate points in the electrical system such as the fuse box or the auxiliary contacts on the ignition switch. To prevent equipment damage or fire, in-line fuses should be installed in the positive leads where they are attached to the battery post.

An MOV should be installed between the two leads of the equipment power cord. A GE MOV (V36ZA80) is recommended for this application. This MOV provides the lowest measured clamping voltage (170 V) and is low in cost.

## Mobile Antenna Installation

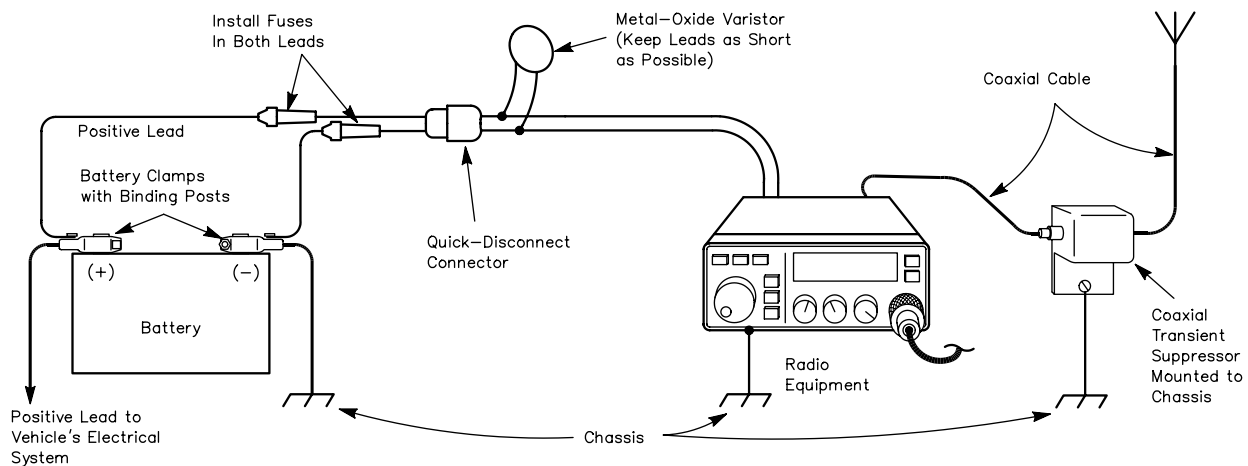
Although tests indicate that mobile radios can survive an EMP transient without protection for the antenna system, protection from lightning transients is still required. A coaxial-line transient suppressor should be installed on the vehicle chassis between the antenna and the radio's antenna connector.

A Fischer suppressor can be attached to a UHF receptacle that is mounted on, and grounded to, the vehicle chassis. The Polyphaser protector can be mounted on, and grounded to, the vehicle chassis with its flange. Use a short length of coaxial cable between the radio and the transient suppressor.

## Clamping Voltage Calculation

When selecting any EMP-protection device to be used at the antenna port of a radio, several items must be considered. These include transmitter RF power output, the SWR, and the operating frequency. The protection device must allow the outgoing RF signal to pass without clamping. A clamping voltage calculation must be made for each amateur installation.

The RF-power input to a transmission line develops a corresponding voltage that becomes important when a voltage-surge arrester is in the line. SWR is important



**Fig 17—Recommended method of connecting mobile radio equipment to the vehicle battery and antenna.**

because of its influence on the voltage level. The maximum voltage developed for a given power input is determined by:

$$V = \sqrt{2 \times P \times Z \times \text{SWR}} \quad (\text{Eq 1})$$

where

P = peak power in W

Z = impedance of the coaxial cable ( $\Omega$ )

V = peak voltage across the cable

Eq 1 should be used to determine the peak voltage present across the transmission line. Because the RF transient-protection devices use gas-discharge tubes, the voltage level at which they clamp is not fixed; a safety margin must be added to the calculated peak voltage. This is done by multiplying the calculated value by a factor of three. This added safety margin is required to ensure that the transmitter's RF output power will pass through the transient suppressor without causing the device to clamp the RF signal to ground. The final clamping voltage obtained is then high enough to allow normal operation of the transmitter while providing the lowest practical clamping voltage for the suppression device. This ensures the maximum possible protection for the radio system.

Here's how to determine the clamping voltage required. Let's assume the SWR is 1.5:1. The power output of the transceiver is 100 W PEP. RG-8 coaxial cable has an impedance of 52  $\Omega$ . Therefore:

P = 100 W

Z = 52  $\Omega$

SWR = 1.5

Substituting these values into Eq 1:

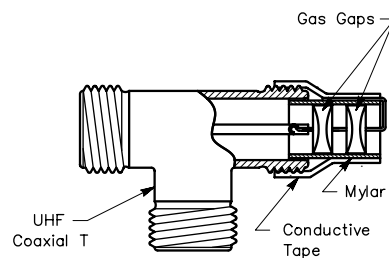
$$V = \sqrt{2 \times 100 \times 52 \times 1.5} = 124.89 \text{ V peak}$$

Note that the voltage, V, is the peak value at the peak of the RF envelope. The final clamping voltage (FCV) is three times this value, or 374.7 V. Therefore, a coaxial-line transient suppressor that clamps at or above 375 V should be used.

The cost of a two-point basic protection scheme is estimated to be \$100 for each fixed amateur station. This includes the cost of a good quality plug-in power-line protector (\$45) and one Fischer coaxial-line protector (\$55).

### Inexpensive Transient-Protection Devices

The radio antenna connection can be protected by means of another simple device. As shown in **Fig 18**, two spark gaps (Siemens BI-A350) are installed in series at one end of a coaxial-cable T connector. Use the shortest practical lead length (about 1/4 inch) between the two spark gaps. One lead is bent forward and forced between the split sections of the inner coaxial connector until the spark gaps approach the body of the connector. A short length of insulating material (such as Mylar) is placed between the spark gaps and the connector shell. The other spark-gap lead is folded over the insulator, then conductive (metallic) tape is wrapped around the assembly. This construction method proved



**Fig 18—Pictorial diagram of an inexpensive, homemade RF coax transient protector.**

durable enough to allow many insertions and removals of the device during testing. Estimated cost of this assembly is \$9. Similar devices can be built using components from Joslyn, General Electric, General Semiconductor or Siemens.

### Summary

Amateurs should be aware of which components in their radio system are most likely to be damaged by EMP. They should also know how to repair the damaged equipment. Amateurs should know how to reestablish communications after an EMP event, taking into consideration its adverse effects on the earth's atmosphere and radio equipment. One of the first things that would be noticed, providing the radio equipment is operative, is a sudden silence in radio transmissions across all frequencies below approximately 100 MHz. This silence would be caused in part by damage to unprotected radio gear from the EMP transient. Transmissions from one direction, the direction of the nuclear blast, would be completely out. RF signal loss by absorption and attenuation by the nuclear fireball are the reasons for this.

After an EMP event, the amateur should be prepared to operate CW. CW gives the most signal power under adverse conditions. It also provides a degree of message security from the general public.

Amateurs should develop the capability and flexibility to operate in more than one frequency band. The lower ground-wave frequencies should be useful for long-distance communications immediately after an EMP event. Line-of-sight VHF would be of value for local communications.

What can be done to increase the survivability of an Amateur Radio station? Here are some suggestions:

- 1) If you have spare equipment, keep it disconnected; use only the primary station gear. The spare equipment would then be available after an EMP event.
- 2) Keep equipment turned off and antenna and power lines disconnected when the equipment is not in use.
- 3) Connect only those external conductors necessary for the current mode of operation.
- 4) Tie all fixed equipment to a single-point earth ground to prevent closed loops through the ground.
- 5) Obtain schematic diagrams of your equipment and tools for repair of the equipment.

- 6) Have spare parts on hand for sensitive components of the radio equipment and antenna system.
- 7) Learn how to repair or replace the sensitive components of the radio equipment.
- 8) Use nonmetallic guy lines and antenna structural parts where possible.
- 9) Obtain an emergency power source and operate from it during periods of increased world political tension. The power source should be completely isolated from the commercial power lines.
- 10) Equipment power cords should be disconnected when the gear is idle. Or the circuit breaker for the line feeding the equipment should be kept in the OFF position when the station is off the air.
- 11) Disconnect the antenna lead-in when the station is off the air. Or use a grounding antenna switch and keep it in

- the GROUND position when the equipment is not in use.
- 12) Have a spare antenna and transmission line on hand to replace a damaged antenna system.
- 13) Install EMP surge arresters and filters on all primary conductors attached to the equipment and antenna.
- 14) Retain tube type equipment and spare components; keep them in good working order.
- 15) Do not rely on a microprocessor to control the station after an EMP event. Be able to operate without microprocessor control.

The recommendations contained in this section were developed with low cost in mind; they are not intended to cover all possible combinations of equipment and installation methods found in the amateur community. Amateurs should examine their own requirements and use this report as a guideline in providing protection for the equipment.

## RF Radiation and Electromagnetic Field Safety

Amateur Radio is basically a safe activity. In recent years, however, there has been considerable discussion and concern about the possible hazards of electromagnetic radiation (EMR), including both RF energy and power-frequency (50-60 Hz) electromagnetic (EM) fields. FCC regulations set limits on the maximum permissible exposure (MPE) allowed from the operation of radio transmitters. These regulations do not take the place of RF-safety practices, however. This section deals with the topic of RF safety.

This section was prepared by members of the ARRL RF Safety Committee and coordinated by Dr Robert E. Gold, WB0KIZ. It summarizes what is now known and offers safety precautions based on the research to date.

All life on Earth has adapted to survive in an environment of weak, natural, low-frequency electromagnetic fields (in addition to the Earth's static geomagnetic field). Natural low-frequency EM fields come from two main sources: the sun, and thunderstorm activity. But in the last 100 years, man-made fields at much higher intensities and with a very different spectral distribution have altered this natural EM background in ways that are not yet fully understood. Researchers continue to look at the effects of RF exposure over a wide range of frequencies and levels.

Both RF and 60-Hz fields are classified as *nonionizing radiation*, because the frequency is too low for there to be enough photon energy to ionize atoms. (*Ionizing radiation*, such as X-rays, gamma rays and even some ultraviolet radiation has enough energy to knock electrons loose from their atoms. When this happens, positive and negative ions are formed.) Still, at sufficiently high power densities, EMR poses certain health hazards. It has been known since the early days of radio that RF energy can cause injuries by heating body tissue. (Anyone who has ever touched an improperly grounded radio chassis or energized antenna and

received an *RF burn* will agree that this type of injury can be quite painful.) In extreme cases, RF-induced heating in the eye can result in cataract formation, and can even cause blindness. Excessive RF heating of the reproductive organs can cause sterility. Other health problems also can result from RF heating. These heat-related health hazards are called *thermal effects*. A microwave oven is a positive application of this thermal effect.

There also have been observations of changes in physiological function in the presence of RF energy levels that are too low to cause heating. These functions return to normal when the field is removed. Although research is ongoing, no harmful health consequences have been linked to these changes.

In addition to the ongoing research, much else has been done to address this issue. For example, FCC regulations set limits on exposure from radio transmitters. The Institute of Electrical and Electronics Engineers, the American National Standards Institute and the National Council for Radiation Protection and Measurement, among others, have recommended voluntary guidelines to limit human exposure to RF energy. The ARRL has established the RF Safety Committee, consisting of concerned medical doctors and scientists, serving voluntarily to monitor scientific research in the fields and to recommend safe practices for radio amateurs.

### THERMAL EFFECTS OF RF ENERGY

Body tissues that are subjected to *very high* levels of RF energy may suffer serious heat damage. These effects depend on the frequency of the energy, the power density of the RF field that strikes the body and factors such as the polarization of the wave.

At frequencies near the body's natural resonant frequency, RF energy is absorbed more efficiently, and an

increase in heating occurs. In adults, this frequency usually is about 35 MHz if the person is grounded, and about 70 MHz if insulated from the ground. Individual body parts may be resonant at different frequencies. The adult head, for example, is resonant around 400 MHz, while a baby's smaller head resonates near 700 MHz. Body size thus determines the frequency at which most RF energy is absorbed. As the frequency is moved farther from resonance, less RF heating generally occurs. *Specific absorption rate (SAR)* is a term that describes the rate at which RF energy is absorbed in tissue.

Maximum permissible exposure (MPE) limits are based on whole-body SAR values, with additional safety factors included as part of the standards and regulations. This helps explain why these safe exposure limits vary with frequency. The MPE limits define the maximum electric and magnetic field strengths or the plane-wave equivalent power densities associated with these fields that a person may be exposed to without harmful effect—and with an acceptable safety factor. The regulations assume that a person exposed to a specified (safe) MPE level also will experience a safe SAR.

Nevertheless, thermal effects of RF energy should not be a major concern for most radio amateurs, because of the power levels we normally use and the intermittent nature of most amateur transmissions. Amateurs spend more time listening than transmitting, and many amateur transmissions such as CW and SSB use low-duty-cycle modes. (With FM or RTTY, though, the RF is present continuously at its maximum level during each transmission.) In any event, it is rare for radio amateurs to be subjected to RF fields strong enough to produce thermal effects, unless they are close to an energized antenna or unshielded power amplifier. Specific suggestions for avoiding excessive exposure are offered later in this chapter.

### **ATHERMAL EFFECTS OF EMR**

Research about possible health effects resulting from exposure to the lower level energy fields, the athermal effects, has been of two basic types: epidemiological research and laboratory research.

Scientists conduct laboratory research into biological mechanisms by which EMR may affect animals including humans. Epidemiologists look at the health patterns of large groups of people using statistical methods. These epidemiological studies have been inconclusive. By their basic design, these studies do not demonstrate cause and effect, nor do they postulate mechanisms of disease. Instead, epidemiologists look for associations between an environmental factor and an observed pattern of illness. For example, in the earliest research on malaria, epidemiologists observed the association between populations with high prevalence of the disease and the proximity of mosquito infested swamplands. It was left to the biological and medical scientists to isolate the organism causing malaria in the blood of those with the disease, and identify the same organisms in the mosquito population.

In the case of athermal effects, some studies have identified a weak association between exposure to EMF at home or at work and various malignant conditions including leukemia and brain cancer. A larger number of equally well designed and performed studies, however, have found no association. A risk ratio of between 1.5 and 2.0 has been observed in positive studies (the number of observed cases of malignancy being 1.5 to 2.0 times the “expected” number in the population). Epidemiologists generally regard a risk ratio of 4.0 or greater to be indicative of a strong association between the cause and effect under study. For example, men who smoke one pack of cigarettes per day increase their risk for lung cancer tenfold compared to nonsmokers, and two packs per day increases the risk to more than 25 times the nonsmokers' risk.

Epidemiological research by itself is rarely conclusive, however. Epidemiology only identifies health patterns in groups—it does not ordinarily determine their cause. And there are often confounding factors: Most of us are exposed to many different environmental hazards that may affect our health in various ways. Moreover, not all studies of persons likely to be exposed to high levels of EMR have yielded the same results.

There also has been considerable laboratory research about the biological effects of EMR in recent years. For example, some separate studies have indicated that even fairly low levels of EMR might alter the human body's circadian rhythms, affect the manner in which T lymphocytes function in the immune system and alter the nature of the electrical and chemical signals communicated through the cell membrane and between cells, among other things. Although these studies are intriguing, they do not demonstrate any effect of these low-level fields on the overall organism.

Much of this research has focused on low-frequency magnetic fields, or on RF fields that are keyed, pulsed or modulated at a low audio frequency (often below 100 Hz). Several studies suggested that humans and animals can adapt to the presence of a steady RF carrier more readily than to an intermittent, keyed or modulated energy source.

The results of studies in this area, plus speculations concerning the effect of various types of modulation, were and have remained somewhat controversial. None of the research to date has demonstrated that low-level EMR causes adverse health effects.

Given the fact that there is a great deal of ongoing research to examine the health consequences of exposure to EMF, the American Physical Society (a national group of highly respected scientists) issued a statement in May 1995 based on its review of available data pertaining to the possible connections of cancer to 60-Hz EMF exposure. This report is exhaustive and should be reviewed by anyone with a serious interest in the field. Among its general conclusions were the following:

1. The scientific literature and the reports of reviews by other panels show no consistent, significant link between cancer and power line fields.

2. No plausible biophysical mechanisms for the systematic initiation or promotion of cancer by these extremely weak 60-Hz fields has been identified.
3. While it is impossible to prove that no deleterious health effects occur from exposure to any environmental factor, it is necessary to demonstrate a consistent, significant, and causal relationship before one can conclude that such effects do occur.

In a report dated October 31, 1996, a committee of the National Research Council of the National Academy of Sciences has concluded that no clear, convincing evidence exists to show that residential exposures to electric and magnetic fields (EMFs) are a threat to human health.

A National Cancer Institute epidemiological study of residential exposure to magnetic fields and acute lymphoblastic leukemia in children was published in the *New England Journal of Medicine* in July 1997. The exhaustive, seven-year study concludes that if there is any link at all, it is far too weak to be concerned about.

Readers may want to follow this topic as further studies are reported. Amateurs should be aware that exposure to RF and ELF (60 Hz) electromagnetic fields at all power levels and frequencies has not been fully studied under all circumstances. “Prudent avoidance” of any avoidable EMR is always a good idea. Prudent avoidance doesn’t mean that amateurs should be fearful of using their equipment. Most amateur operations are well within the MPE limits. If any risk does exist, it will almost surely fall well down on the list of causes that may be harmful to your health (on the other end of the list from your automobile). It does mean, however, that hams should be aware of the potential for exposure from their stations, and take whatever reasonable steps they can take to minimize their own exposure and the exposure of those around them.

### Safe Exposure Levels

How much EM energy is safe? Scientists and regulators have devoted a great deal of effort to deciding upon safe RF-exposure limits. This is a very complex problem, involving difficult public health and economic considerations. The recommended safe levels have been revised downward several times over the years—and not all scientific bodies agree on this question even today. An Institute of Electrical and Electronics Engineers (IEEE) standard for recommended EM exposure limits was published in 1991 (see Bibliography). It replaced a 1982 American National Standards Institute (ANSI) standard. In the new standard, most of the permitted exposure levels were revised downward (made more stringent) to better reflect the current research. The new IEEE standard was adopted by ANSI in 1992.

The IEEE standard recommends frequency-dependent and time-dependent maximum permissible exposure levels. Unlike earlier versions of the standard, the 1991 standard recommends different RF exposure limits in controlled environments (that is, where energy levels can be accurately determined and everyone on the premises is aware of the

presence of EM fields) and in uncontrolled environments (where energy levels are not known or where people may not be aware of the presence of EM fields). FCC regulations also include controlled/occupational and uncontrolled/general population exposure environments.

The graph in [Fig 19](#) depicts the 1991 IEEE standard. It is necessarily a complex graph, because the standards differ not only for controlled and uncontrolled environments but also for electric (E) fields and magnetic (H) fields. Basically, the lowest E-field exposure limits occur at frequencies between 30 and 300 MHz. The lowest H-field exposure levels occur at 100-300 MHz. The ANSI standard sets the maximum E-field limits between 30 and 300 MHz at a power density of 1 mW/cm<sup>2</sup> (61.4 V/m) in controlled environments—but at one-fifth that level (0.2 mW/cm<sup>2</sup> or 27.5 V/m) in uncontrolled environments. The H-field limit drops to 1 mW/cm<sup>2</sup> (0.163 A/m) at 100-300 MHz in controlled environments and 0.2 mW/cm<sup>2</sup> (0.0728 A/m) in uncontrolled environments. Higher power densities are permitted at frequencies below 30 MHz (below 100 MHz for H fields) and above 300 MHz, based on the concept that the body will not be resonant at those frequencies and will therefore absorb less energy.

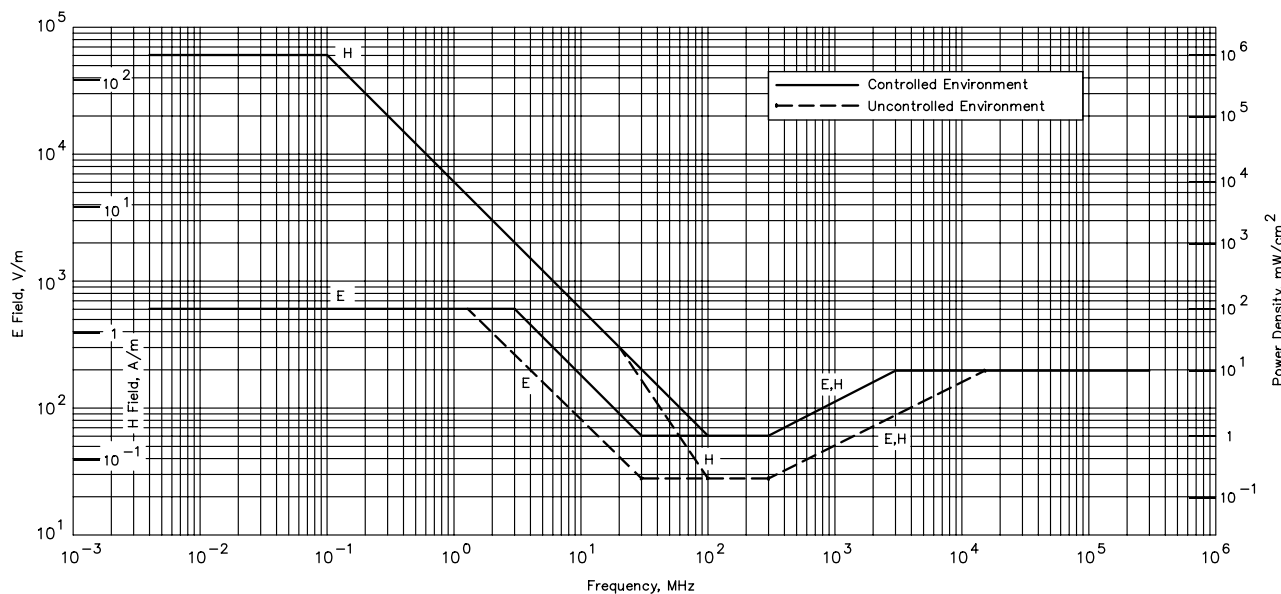
In general, the 1991 IEEE standard requires averaging the power level over time periods ranging from 6 to 30 minutes for power-density calculations, depending on the frequency and other variables. The ANSI exposure limits for uncontrolled environments are lower than those for controlled environments, but to compensate for that the standard allows exposure levels in those environments to be averaged over much longer time periods (generally 30 minutes). This long averaging time means that an intermittently operating RF source (such as an Amateur Radio transmitter) will show a much lower power density than a continuous-duty station—for a given power level and antenna configuration.

Time averaging is based on the concept that the human body can withstand a greater rate of body heating (and thus, a higher level of RF energy) for a short time than for a longer period. Time averaging may not be appropriate, however, when considering nonthermal effects of RF energy.

The IEEE standard excludes any transmitter with an output below 7 W because such low-power transmitters would not be able to produce significant whole-body heating. (Recent studies show that hand-held transceivers often produce power densities in excess of the IEEE standard within the head.)

There is disagreement within the scientific community about these RF exposure guidelines. The IEEE standard is still intended primarily to deal with thermal effects, not exposure to energy at lower levels. A small but significant number of researchers now believe athermal effects also should be taken into consideration. Several European countries and localities in the United States have adopted stricter standards than the recently updated IEEE standard.

Another national body in the United States, the National Council for Radiation Protection and Measurement (NCRP),



**Fig 19—1991 RF protection guidelines for body exposure of humans. It is known officially as the “IEEE Standard for Safety Levels with Respect to Human Exposure to Radio Frequency Electromagnetic Fields, 3 kHz to 300 GHz.”**

also has adopted recommended exposure guidelines. NCRP urges a limit of 0.2 mW/cm<sup>2</sup> for nonoccupational exposure in the 30-300 MHz range. The NCRP guideline differs from IEEE in two notable ways: It takes into account the effects of modulation on an RF carrier, and it does not exempt transmitters with outputs below 7 W.

The FCC MPE regulations are based on parts of the 1992 IEEE/ANSI standard and recommendations of the National Council for Radiation Protection and Measurement (NCRP). The MPE limits under the regulations are slightly different than the IEEE/ANSI limits. Note that the MPE levels apply to the FCC rules put into effect for radio amateurs on January 1, 1998. These MPE requirements do not reflect and include all the assumptions and exclusions of the IEEE/ANSI standard.

### Cardiac Pacemakers and RF Safety

It is a widely held belief that cardiac pacemakers may be adversely affected in their function by exposure to electromagnetic fields. Amateurs with pacemakers may ask whether their operating might endanger themselves or visitors to their shacks who have a pacemaker. Because of this, and similar concerns regarding other sources of electromagnetic fields, pacemaker manufacturers apply design methods that for the most part shield the pacemaker circuitry from even relatively high EM field strengths.

It is recommended that any amateur who has a pacemaker, or is being considered for one, discuss this matter with his or her physician. The physician will probably put the amateur into contact with the technical representative of the

pacemaker manufacturer. These representatives are generally excellent resources, and may have data from laboratory or “in the field” studies with specific model pacemakers.

One study examined the function of a modern (dual chamber) pacemaker in and around an Amateur Radio station. The pacemaker generator has circuits that receive and process electrical signals produced by the heart, and also generate electrical signals that stimulate (pace) the heart. In one series of experiments, the pacemaker was connected to a heart simulator. The system was placed on top of the cabinet of a 1-kW HF linear amplifier during SSB and CW operation. In another test, the system was placed in close proximity to several 1 to 5-W 2-meter hand-held transceivers. The test pacemaker was connected to the heart simulator in a third test, and then placed on the ground 9 meters below and 5 meters in front of a three-element Yagi HF antenna. No interference with pacemaker function was observed in these experiments.

Although the possibility of interference cannot be entirely ruled out by these few observations, these tests represent more severe exposure to EM fields than would ordinarily be encountered by an amateur—with an average amount of common sense. Of course, prudence dictates that amateurs with pacemakers, who use hand-held VHF transceivers, keep the antenna as far as possible from the site of the implanted pacemaker generator. They also should use the lowest transmitter output required for adequate communication. For high power HF transmission, the antenna should be as far as possible from the operating position, and all equipment should be properly grounded.

## FCC RF-Exposure Regulations

FCC regulations control the amount of RF exposure that can result from your station's operation (§§97.13, 97.503, 1.1307 (b)(c)(d), 1.1310 and 2.1093). The regulations set limits on the maximum permissible exposure (MPE) allowed from operation of transmitters in all radio services. They also require that certain types of stations be evaluated to determine if they are in compliance with the MPEs specified in the rules. The FCC has also required that five questions on RF environmental safety practices be added to Novice, Technician and General license examinations.

These rules went into effect on January 1, 1998 for new stations or stations that file a Form 605 application with the FCC. Other existing stations have until September 1, 2000 to be in compliance with the rules.

### The Rules

#### Maximum Permissible Exposure (MPE)

All radio stations regulated by the FCC must comply with the requirements for MPEs, even QRP stations running only a few watts or less. The MPEs vary with frequency, as shown in **Table A**. MPE limits are specified in maximum electric and magnetic fields for frequencies below 30 MHz, in power density for frequencies above 300 MHz and all three ways for frequencies from 30 to 300 MHz. For compliance purposes, all of these limits must be considered *separately*. If any one is exceeded, the station is not in compliance.

The regulations control human exposure to RF fields, not the strength of RF fields. There is no limit to how strong a field can be as long as no one is being exposed to it, although FCC regulations require that amateurs use the minimum necessary power at all times (§97.311 [a]).

#### Environments

The FCC has defined two exposure environments — *controlled* and *uncontrolled*. A controlled environment is one in which the people who are being exposed are aware of that exposure and can take steps to minimize that exposure, if appropriate. In an uncontrolled environment, the people being exposed are not normally aware of the exposure. The uncontrolled environment limits are more stringent than the controlled environment limits.

Although the controlled environment is usually intended as an occupational environment, the FCC has determined that it generally applies to amateur operators and members of their immediate households. In most cases, controlled-environment limits can be

applied to your home and property to which you can control physical access. The uncontrolled environment is intended for areas that are accessible by the general public, such as your neighbors' properties.

The MPE levels are based on average exposure. An averaging time of 6 minutes is used for controlled exposure; an averaging period of 30 minutes is used for uncontrolled exposure.

#### Station Evaluations

The FCC requires that certain amateur stations be evaluated for compliance with the MPEs. Although an amateur can have someone else do the evaluation, it is not difficult for hams to evaluate their own stations. The ARRL book *RF Exposure and You* contains extensive information about the regulations and a large chapter of tables that show compliance distances for specific antennas and power levels. Generally, hams will use these tables to evaluate their stations. Some of these tables have been included in the FCC's information — *OET Bulletin 65* and its *Supplement B*. If hams choose, however, they can do more extensive calculations, use a computer to model their antenna and exposure, or make actual measurements.

#### Categorical Exemptions

Some types of amateur stations do not need to be evaluated, but these stations must still comply with the MPE limits. The station licensee remains

**Table A—(From §1.1310) Limits for Maximum Permissible Exposure (MPE)**

(A) Limits for Occupational/Controlled Exposure

Frequency Range (MHz)	Electric Field Strength (V/m)	Magnetic Field Strength (A/m)	Power Density (mW/cm <sup>2</sup> )	Averaging Time (minutes)
0.3-3.0	614	1.63	(100)*	6
3.0-30	1842/f	4.89/f	(900/f <sup>2</sup> )*	6
30-300	61.4	0.163	1.0	6
300-1500	—	—	f/300	6
1500-100,000	—	—	5	6

f = frequency in MHz

\* = Plane-wave equivalent power density (see Note 1).

(B) Limits for General Population/Uncontrolled Exposure

Frequency Range (MHz)	Electric Field Strength (V/m)	Magnetic Field Strength (A/m)	Power Density (mW/cm <sup>2</sup> )	Averaging Time (minutes)
0.3-1.34	614	1.63	(100)*	30
1.34-30	824/f	2.19/f	(180/f <sup>2</sup> )*	30
30-300	27.5	0.073	0.2	30
300-1500	—	—	f/1500	30
1500-100,000	—	—	1.0	30

f = frequency in MHz

\* = Plane-wave equivalent power density (see Note 1).

Note 1: This means the equivalent far-field strength that would have the E or H-field component calculated or measured. It does not apply well in the near field of an antenna. The equivalent far-field power density can be found in the near or far field regions from the relationships:  $P_d = |E_{total}|^2 / 3770 \text{ mW/cm}^2$  or from  $P_d = |H_{total}|^2 \times 37.7 \text{ mW/cm}^2$ .

**Table B—Power Thresholds for Routine Evaluation of Amateur Radio Stations**

<b>Wavelength Band</b>	<b>Evaluation Required if Power* (watts) Exceeds:</b>
	<b>MF</b>
160 m	500
	<b>HF</b>
80 m	500
75 m	500
40 m	500
30 m	425
20 m	225
17 m	125
15 m	100
12 m	75
10 m	50
<b>VHF (all bands)</b>	50
	<b>UHF</b>
70 cm	70
33 cm	150
23 cm	200
13 cm	250
<b>SHF (all bands)</b>	250
<b>EHF (all bands)</b>	250
<b>Repeater stations (all bands)</b>	<i>non-building-mounted antennas:</i> height above ground level to lowest point of antenna < 10 m and power > 500 W ERP <i>building-mounted antennas:</i> power > 500 W ERP

\*Transmitter power = Peak-envelope power input to antenna. For repeater stations **only**, power exclusion based on ERP (effective radiated power).

responsible for ensuring that the station meets these requirements.

The FCC has exempted these stations from the evaluation requirement because their output power, operating mode and frequency are such that they are presumed to be in compliance with the rules.

Stations using power equal to or less than the levels in **Table B** do not have to be evaluated. For the 100-W HF ham station, for example, an evaluation would be required *only* on 12 and 10 meters.

Hand-held radios and vehicle-mounted mobile radios that operate using a push-to-talk (PTT) button are also categorically exempt from performing the routine evaluation. Repeater stations that use less than 500 W ERP or those with antennas not mounted on buildings, if the antenna is at least 10 meters off the ground, also do not need to be evaluated.

### Correcting Problems

Most hams are already in compliance with the MPE requirements. Some amateurs, especially those using indoor antennas or high-power, high-duty-cycle modes such as a RTTY bulletin station and specialized stations for moonbounce operations and the like may need to make adjustments to their station or operation to be in compliance.

The FCC permits amateurs considerable flexibility in complying with these regulations. As an example, hams can adjust their operating frequency, mode or power to comply with the MPE limits. They can also adjust their operating habits or control the direction their antenna is pointing.

### More Information

This discussion offers only an overview of this topic; additional information can be found in *RF Exposure and You* and on *ARRLWeb* at <http://www.arrl.org/news/rfsafety/>. *ARRLWeb* has links to the FCC Web site, with *OET Bulletin 65* and *Supplement B* and links to software that hams can use to evaluate their stations.

## Low-Frequency Fields

Although the FCC doesn't regulate 60-Hz fields, some recent concern about EMR has focused on low-frequency energy rather than RF. Amateur Radio equipment can be a significant source of low-frequency magnetic fields, although there are many other sources of this kind of energy in the typical home. Magnetic fields can be measured relatively accurately with inexpensive 60-Hz meters that are made by several manufacturers.

**Table 2** shows typical magnetic field intensities of Amateur Radio equipment and various household items. Because these fields dissipate rapidly with distance, "prudent avoidance" would mean staying perhaps 12 to 18 inches away from most Amateur Radio equipment (and 24 inches from power supplies with 1-kW RF amplifiers).

## Determining RF Power Density

Unfortunately, determining the power density of the RF fields generated by an amateur station is not as simple as measuring low-frequency magnetic fields. Although sophisticated instruments can be used to measure RF power densities quite accurately, they are costly and require frequent recalibration. Most amateurs don't have access to such equipment, and the inexpensive field-strength meters that we do have are not suitable for measuring RF power density.

**Table 3** shows a sampling of measurements made at Amateur Radio stations by the Federal Communications Commission and the Environmental Protection Agency in 1990. As this table indicates, a good antenna well removed from inhabited areas poses no hazard under any of the IEEE/ANSI guidelines. However, the FCC/EPA survey also



indicates that amateurs must be careful about using indoor or attic-mounted antennas, mobile antennas, low directional arrays or any other antenna that is close to inhabited areas, especially when moderate to high power is used.

Ideally, before using any antenna that is in close

**Table 2**  
**Typical 60-Hz Magnetic Fields Near Amateur Radio Equipment and AC-Powered Household Appliances**

Values are in milligauss.

Item	Field	Distance
Electric blanket	30-90	Surface
Microwave oven	10-100	Surface
	1-10	12"
IBM personal computer	5-10	Atop monitor
	0-1	15" from screen
Electric drill	500-2000	At handle
Hair dryer	200-2000	At handle
HF transceiver	10-100	Atop cabinet
	1-5	15" from front
1-kW RF amplifier	80-1000	Atop cabinet
	1-25	15" from front

(Source: measurements made by members of the ARRL RF Safety Committee)

**Table 3**  
**Typical RF Field Strengths Near Amateur Radio Antennas**

A sampling of values as measured by the Federal Communications Commission and Environmental Protection Agency, 1990

Antenna Type	Freq (MHz)	Power (W)	E Field (V/m)	Location
Dipole in attic	14.15	100	7-100	In home
Discone in attic	146.5	250	10-27	In home
Half sloper	21.5	1000	50	1 m from base
Dipole at 7-13 ft	7.14	120	8-150	1-2 m from earth
Vertical	3.8	800	180	0.5 m from base
5-element Yagi at 60 ft	21.2	1000	10-20 14	In shack 12 m from base
3-element Yagi at 25 ft	28.5	425	8-12	12 m from base
Inverted V at 22-46 ft	7.23	1400	5-27	Below antenna
Vertical on roof	14.11	140	6-9 35-100	In house At antenna tuner
Whip on auto roof	146.5	100	22-75 15-30 90	2 m antenna In vehicle Rear seat
5-element Yagi at 20 ft	50.1	500	37-50	10 m antenna

proximity to an inhabited area, you should measure the RF power density. If that is not feasible, the next best option is make the installation as safe as possible by observing the safety suggestions listed in **Table 4**.

It also is possible, of course, to calculate the probable power density near an antenna using simple equations. Such calculations have many pitfalls. For one, most of the situations where the power density would be high enough to be of concern are in the near field. In the near field, ground interactions and other variables produce power densities that cannot be determined by simple arithmetic. In the far field, conditions become easier to predict with simple calculations.

The boundary between the near field and the far field depends on the wavelength of the transmitted signal and the physical size and configuration of the antenna. The boundary between the near field and the far field of an antenna can be as much as several wavelengths from the antenna.

Computer antenna-modeling programs are another approach you can use. *MININEC* or other codes derived from *NEC* (Numerical Electromagnetics Code) are suitable for estimating RF magnetic and electric fields around amateur antenna systems.

These models have limitations. Ground interactions must be considered in estimating near-field power densities, and the "correct ground" must be modeled. Computer modeling is generally not sophisticated enough to predict "hot spots" in the near field—places where the field intensity may be far higher than would be expected, due to reflections from nearby objects. In addition, "nearby objects" often change or vary with weather or the season, so the model so laboriously crafted may not be representative of the actual situation, by the time it is running on the computer.

Intensely elevated but localized fields often can be detected by professional measuring instruments. These "hot spots" are often found near wiring in the shack, and metal objects such as antenna masts or equipment cabinets. But even with the best instrumentation, these measurements also may be misleading in the near field.

One need not make precise measurements or model the exact antenna system, however, to develop some idea of the relative fields around an antenna. Computer modeling using close approximations of the geometry and power input of the antenna will generally suffice. Those who are familiar with *MININEC* can estimate their power densities by computer modeling, and those who have access to professional power-density meters can make useful measurements.

While our primary concern is ordinarily the intensity of the signal radiated by an antenna, we also should remember that there are other potential energy sources to be considered. You also can be exposed to RF radiation directly from a power amplifier if it is operated without proper shielding. Transmission lines also may radiate a significant amount of energy under some conditions. Poor microwave waveguide joints or improperly assembled connectors are another source of incidental radiation.

---

## Table 4

### RF Awareness Guidelines

These guidelines were developed by the ARRL RF Safety Committee, based on the FCC/EPA measurements of [Table 3](#) and other data.

- Although antennas on towers (well away from people) pose no exposure problem, make certain that the RF radiation is confined to the antennas' radiating elements themselves. Provide a single, good station ground (earth), and eliminate radiation from transmission lines. Use good coaxial cable or other feed line properly. Avoid serious imbalance in your antenna system and feed line. For high-powered installations, avoid end-fed antennas that come directly into the transmitter area near the operator.
- No person should ever be near any transmitting antenna while it is in use. This is especially true for mobile or ground-mounted vertical antennas. Avoid transmitting with more than 25 W in a VHF mobile installation unless it is possible to first measure the RF fields inside the vehicle. At the 1-kW level, both HF and VHF directional antennas should be at least 35 ft above inhabited areas. Avoid using indoor and attic-mounted antennas if at all possible. If open-wire feeders are used, ensure that it is not possible for people (or animals) to come into accidental contact with the feed line.
- Don't operate high-power amplifiers with the covers removed, especially at VHF/UHF.
- In the UHF/SHF region, never look into the open end of an activated length of waveguide or microwave feed-horn antenna or point it toward anyone. (If you do, you may be exposing your eyes to more than the maximum permissible exposure level of RF radiation.) Never point a high-gain, narrow-bandwidth antenna (a paraboloid, for instance) toward people. Use caution in aiming an EME (moonbounce) array toward the horizon; EME arrays may deliver an effective radiated power of 250,000 W or more.
- With hand-held transceivers, keep the antenna away from your head and use the lowest power possible to maintain communications. Use a separate microphone and hold the rig as far away from you as possible. This will reduce your exposure to the RF energy.
- Don't work on antennas that have RF power applied.
- Don't stand or sit close to a power supply or linear amplifier when the ac power is turned on. Stay at least 24 inches away from power transformers, electrical fans and other sources of high-level 60-Hz magnetic fields.

---

### Further RF Exposure Suggestions

Potential exposure situations should be taken seriously. Based on the FCC/EPA measurements and other data, the "RF awareness" guidelines of **Table 4** were developed by the ARRL RF Safety Committee. A longer version of these guidelines, along with a complete list of references, appeared in a *QST* article by Ivan Shulman, MD, WC2S ("Is Amateur Radio Hazardous to Our Health?" *QST*, Oct 1989, pp 31-34).

In addition, the ARRL has published a book, *RF Exposure and You*, that is helping hams comply with the FCC's RF-exposure regulations. The ARRL also maintains an RF-exposure news page on its Web site. See <http://www.arrl.org/news/rfsafety>. This site contains reprints of selected *QST* articles on RF exposure and links to the FCC and other useful sites.

# Chapter 2

# Antenna Fundamentals

Antennas belong to a class of devices called *transducers*. This term is derived from two Latin words, meaning literally “to lead across” or “to transfer.” Thus, a transducer is a device that transfers, or converts, energy from one form to another. The purpose of an antenna is to convert radio-frequency electric current to *electromagnetic waves*, which are then *radiated* into space. [For more details on the properties of electromagnetic waves themselves, see [Chapter 23, Radio Wave Propagation](#).]

We cannot directly see or hear, taste or touch electromagnetic waves, so it’s not surprising that the process by which they are launched into space from our antennas can be a little mystifying, especially to a newcomer. In everyday life we come across many types of transducers, although we don’t always recognize them as such. A comparison with a type of transducer that you can actually see and touch may be useful. You are no doubt familiar with a *loudspeaker*. It converts audio-frequency electric current from the output of your radio or stereo into acoustic pressure waves, also known as *sound waves*. The sound waves are propagated through the air to your ears, where they are converted into what you perceive as sound.

We normally think of a loudspeaker as something that converts electrical energy into sound energy, but we could just as well turn things around and apply sound energy to a

loudspeaker, which will then convert it into electrical energy. When used in this manner, the loudspeaker has become a microphone. The loudspeaker/microphone thus exhibits the principle of *reciprocity*, derived from the Latin word meaning to move back and forth.

Now, let’s look more closely at that special transducer we call an *antenna*. When fed by a transmitter with RF current (usually through a transmission line), the antenna launches electromagnetic waves, which are propagated through space. This is similar to the way sound waves are propagated through the air by a loudspeaker. In the next town, or perhaps on a distant continent, a similar transducer (that is, a receiving antenna) intercepts some of these electromagnetic waves and converts them into electrical current for a receiver to amplify and detect.

In the same fashion that a loudspeaker can act as a microphone, a radio antenna also follows the principle of reciprocity. In other words, an antenna can transmit as well as receive signals. However, unlike the loudspeaker, an antenna does not require a *medium*, such as air, through which it radiates electromagnetic waves. Electromagnetic waves can be propagated through air, the vacuum of outer space or the near-vacuum of the upper ionosphere. This is the miracle of radio—electromagnetic waves can propagate without a physical medium.

## Essential Characteristics of Antennas

What other things make an antenna different from an ordinary electronic circuit? In ordinary circuits, the dimensions of coils, capacitors and connections usually are small compared with the wavelength of the frequency in use. Here, we define wavelength as the distance in free space traveled during one complete cycle of a wave. The velocity of a wave in free space is the speed of light, and the wavelength is thus:

$$\lambda_{\text{meters}} = \frac{279.7925 \times 10^6 \text{ meters/sec}}{\text{f hertz}} = \frac{299.7925}{\text{f MHz}} \quad (\text{Eq 1})$$

where  $\lambda_{\text{meters}}$ , the Greek letter “lambda,” is the free-space wavelength in meters.

Expressed in feet, Eq 1 becomes:

$$\lambda_{\text{feet}} = \frac{983.5592}{\text{f (MHz)}} \approx \frac{983.6}{\text{f (MHz)}} \quad (\text{Eq 2})$$

When circuit dimensions are small compared to  $\lambda$ , most of the electromagnetic energy is confined to the circuit itself, and is used up either performing useful work or is converted into heat. However, when the dimensions of wiring or components become significant compared with the wavelength, some of the energy escapes by radiation in the form of electromagnetic waves.

Antennas come in an enormous, even bewildering, assortment of shapes and sizes. This chapter on fundamentals

will deal with the theory of simple forms of antennas, usually in “free space,” away from the influence of ground. Subsequent chapters will concentrate on more exotic or specialized antenna types. [Chapter 3](#) deals with the complicated subject of the effect of ground, including the effect of uneven local terrain. Ground has a profound influence on how an antenna performs in the real world.

No matter what form an antenna takes, simple or complex, its electrical performance can be characterized according to the following important properties:

1. Feed-point Impedance
2. Directivity, Gain and Efficiency
3. Polarization

## FEED-POINT IMPEDANCE

The first major characteristic defining an antenna is its *feed-point impedance*. Since we amateurs are free to choose our operating frequencies within assigned bands, we need to consider how the feed-point impedance of a particular antenna varies with frequency, within a particular band, or even in several different bands if we intend to use one antenna on multiple bands.

There are two forms of impedance associated with any antenna: *self impedance* and *mutual impedance*. As you might expect, self impedance is what you measure at the feed-point terminals of an antenna located completely away from the influence of any other conductors.

Mutual, or coupled, impedance is due to the parasitic effect of nearby conductors; that is, conductors located within the antenna’s reactive near field. (The subject of fields around an antenna will be discussed in detail later.) This includes the effect of ground, which is a lossy conductor, but a conductor nonetheless. Mutual impedance is defined using Ohm’s Law, just like self impedance. However, mutual impedance is the ratio of voltage in one conductor, divided by the current in another (coupled) conductor. Mutually coupled conductors can distort the pattern of a highly directive antenna, as well as change the impedance seen at the feed point.

In this chapter on fundamentals, we won’t directly deal with mutual impedance, considering it as a side effect of nearby conductors. Instead, here we’ll concentrate on simple antennas in free space, away from ground and any other conductors. Mutual impedance will be considered in detail in [Chapter 11](#) on HF Yagi Arrays, where it is essential for proper operation of these beam antennas.

### Self Impedance

The current that flows into an antenna’s feed point must be supplied at a finite voltage. The self impedance of the antenna is simply equal to the voltage applied to its feed point divided by the current flowing into the feed point. Where the current and voltage are exactly in phase, the impedance is purely resistive, with zero reactive component. For this case the antenna is termed *resonant*. (Amateurs often use the term “resonant” rather loosely, usually meaning

“nearly resonant” or “close-to resonant.”)

You should recognize that an antenna *need not be resonant* in order to be an effective radiator. There is in fact nothing magic about having a resonant antenna, provided of course that you can devise some efficient means to feed the antenna. Many amateurs use non-resonant (even random-length) antennas fed with open-wire transmission lines and antenna tuners. They radiate signals just as well as those using coaxial cable and resonant antennas, and as a bonus they usually can use these antenna systems on multiple frequency bands. It is important to consider an antenna and its feed line as a *system*, in which all losses should be kept to a minimum. See [Chapter 24](#) for details on transmission line loss as a function of impedance mismatch.

Except at the one frequency where it is truly resonant, the current in an antenna is at a different phase compared to the applied voltage. In other words, the antenna exhibits a feed-point *impedance*, not just a pure resistance. The feed-point impedance is composed of either capacitive or inductive reactance in series with a resistance.

### Radiation Resistance

The power supplied to an antenna is dissipated in two ways: radiation of electromagnetic waves, and heat losses in the wire and nearby dielectrics. The radiated power is what we want, the useful part, but it represents a form of “loss” just as much as the power used in heating the wire or nearby dielectrics is a loss. In either case, the dissipated power is equal to  $I^2R$ . In the case of heat losses,  $R$  is a real resistance. In the case of radiation, however,  $R$  is a “virtual” resistance, which, if replaced with an actual resistor of the same value, would dissipate the power that is actually radiated from the antenna. This resistance is called the *radiation resistance*. The total power in the antenna is therefore equal to  $I^2(R_0 + R)$ , where  $R_0$  is the radiation resistance and  $R$  represents the total of all the loss resistances.

In ordinary antennas operated at amateur frequencies, the power lost as heat in the conductor does not exceed a few percent of the total power supplied to the antenna. Expressed in decibels, the loss is less than 0.1 dB. The RF loss resistance of copper wire even as small as #14 is very low compared with the radiation resistance of an antenna that is reasonably clear of surrounding objects and is not too close to the ground. You can therefore assume that the ohmic loss in a reasonably well-located antenna is negligible, and that the total resistance shown by the antenna (the feed-point resistance) is radiation resistance. As a radiator of electromagnetic waves, such an antenna is a highly efficient device.

### Impedance of a Center-Fed Dipole

A fundamental type of antenna is the *center-fed half-wave dipole*. Historically, the  $\lambda/2$  dipole has been the most popular antenna used by amateurs worldwide, largely because it is very simple to construct and because it is an effective performer. It is also a basic building block for many other antenna systems, including beam antennas, such as Yagis.

A center-fed half-wave dipole consists of a straight wire, one-half wavelength long as defined in Eq 1, and fed in the center. The term “dipole” derives from Greek words meaning “two poles.” See **Fig 1**. A  $\lambda/2$ -long dipole is just one form a “dipole” can take. Actually, a center-fed dipole can be any length electrically, as long as it is configured in a symmetrical fashion with two equal-length legs. There are also versions of dipoles that are not fed in the center. These are called *off-center-fed dipoles*, sometimes abbreviated as “OCF dipoles.”

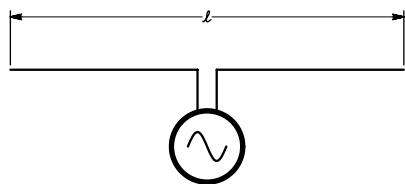
In free space—with the antenna remote from everything else—the theoretical impedance of a physically half-wave long antenna made of an infinitely thin conductor is  $73 + j42.5 \Omega$ . This antenna exhibits both resistance and reactance. The positive sign in the  $+j42.5\text{-}\Omega$  reactive term indicates that the antenna exhibits an inductive reactance at its feed point. The antenna is slightly long electrically, compared to the length necessary for exact resonance, where the reactance is zero.

The feed-point impedance of any antenna is affected by the wavelength-to-diameter ratio ( $\lambda/\text{Dia}$ ) of the conductors used. Theoreticians like to specify an “infinitely thin” antenna because it is easier to handle mathematically.

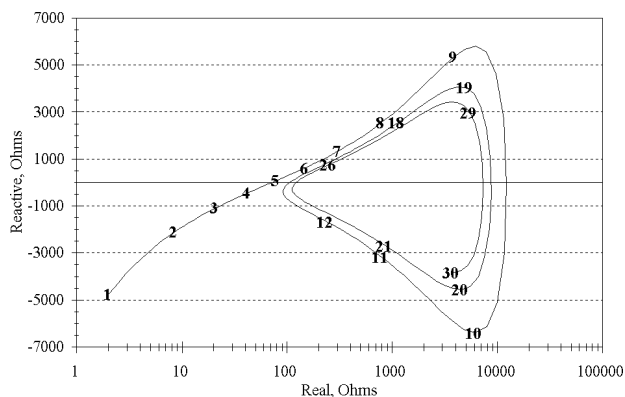
What happens if we keep the physical length of an antenna constant, but change the thickness of the wire used in its construction? Further, what happens if we vary the frequency from well below to well above the half-wave resonance and measure the feed-point impedance? **Fig 2** graphs the impedance of a 100-foot long, center-fed dipole in free space, made with extremely thin wire—in this case, wire that is only 0.001 inches in diameter. There is nothing particularly significant about the choice here of 100 feet. This is simply a numerical example.

We could never actually build such a thin antenna (and neither could we install it in “free space”), but we can model how this antenna works using a very powerful piece of computer software called *NEC-4.1*. See the sidebar “[Antenna Analysis by Computer](#)” later in this chapter.

The frequency applied to the antenna in **Fig 2** is varied from 1 to 30 MHz. The x-axis has a logarithmic scale because of the wide range of feed-point resistance seen over the frequency range. The y-axis has a linear scale representing



**Fig 1**—The center-fed dipole antenna. It is assumed that the source of power is directly at the antenna feed point, with no intervening transmission line. Most commonly in amateur applications, the overall length of the dipole is  $\lambda/2$ , but the antenna can in actuality be any length.

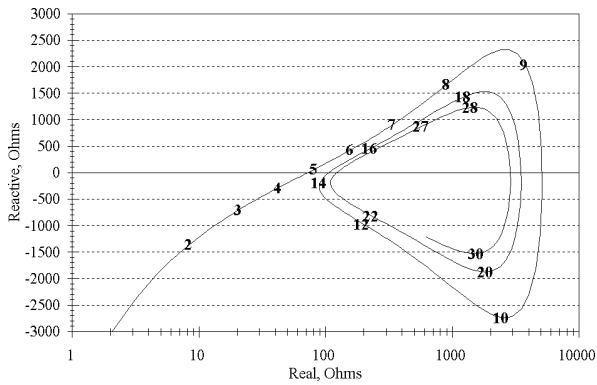


**Fig 2**—Feed-point impedance versus frequency for a theoretical 100-foot long dipole, fed in the center in free space, made of extremely thin 0.001-inch diameter wire. The y-axis is calibrated in positive (inductive) series reactance up from the zero line, and negative (capacitive) series reactance in the downwards direction. The range of reactance goes from  $-6500 \Omega$  to  $+6000 \Omega$ . Note that the x-axis is logarithmic because of the wide range of the real, resistive component of the feed-point impedance, from roughly  $2 \Omega$  to  $10,000 \Omega$ . The numbers placed along the curve show the frequency in MHz. Note that the curve spirals in towards  $377 \Omega$ , the theoretical intrinsic impedance of free space.

the reactive portion of the impedance. Inductive reactance is positive and capacitive reactance is negative on the y-axis. The bold figures centered on the spiraling line show the frequency in MHz.

At 1 MHz, the antenna is very short electrically, with a resistive component of about  $2 \Omega$  and a series capacitive reactance about  $-5000 \Omega$ . Close to 5 MHz, the line crosses the zero-reactance line, meaning that the antenna goes through half-wave resonance there. Between 9 and 10 MHz the antenna exhibits a peak inductive reactance of about  $6000 \Omega$ . It goes through full-wave resonance (again crossing the zero-reactance line) between 9.5 and 9.6 MHz. At about 10 MHz, the reactance peaks at about  $-6500 \Omega$ . Around 14 MHz, the line again crosses the zero-reactance line, meaning that the antenna has now gone through  $3/2$ -wave resonance.

Between 29 and 30 MHz, the antenna goes through  $4/2$ -wave resonance, which is twice the full-wave resonance or four times the half-wave frequency. If you allow your mind’s eye to trace out the curve for frequencies beyond 30 MHz, it eventually spirals down to a resistive component somewhere below about  $400 \Omega$ . This is no coincidence, since this is actually the theoretical  $376.7\text{-}\Omega$  *intrinsic impedance* of free space, the ratio of the complex amplitude of the electric field to that of the magnetic field in free space. This can also be expressed as  $\sqrt{\mu_0/\epsilon_0} = 376.7 \Omega$ , where  $\mu_0$  is the magnetic permeability of a vacuum and  $\epsilon_0$  is the permittivity of a vacuum. Thus, we have another way of looking at an antenna—as a sort of *transformer*, one that

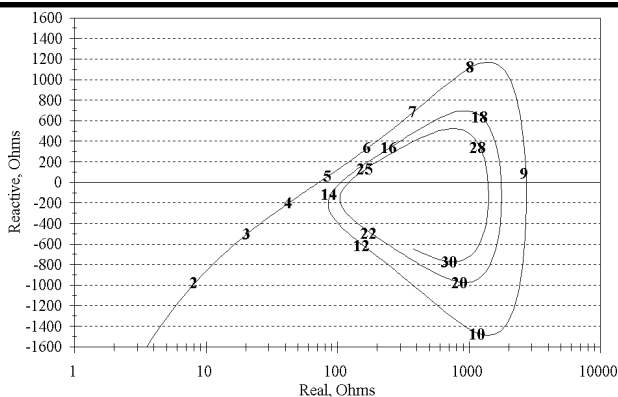


**Fig 3—Feed-point impedance versus frequency for a theoretical 100-foot long dipole, fed in the center in free space, made of thin 0.1-inch (#10) diameter wire. Note that the range of change in reactance is less than that shown in Fig 2, ranging from  $-2700 \Omega$  to  $+2300 \Omega$ . At about  $5,000 \Omega$ , the maximum resistance is also less than that in Fig 2 for the thinner wire, where it is about  $10,000 \Omega$ .**

transforms the free-space intrinsic impedance into the impedance seen at its feed point.

Now look at Fig 3, which shows the same kind of spiral curve, but for a thicker-diameter wire, one that is 0.1 inches in diameter. This diameter is close to #10 wire, a practical size we might actually use to build a real dipole. Note that the y-axis scale in Fig 3 is different from that in Fig 2. The range is from  $\pm 3000 \Omega$  in Fig 3, while it was  $\pm 7000 \Omega$  in Fig 2. The reactance for the thicker antenna ranges from  $+2300$  to  $-2700 \Omega$  over the whole frequency range from 1 to 30 MHz. Compare this with the range of  $+5800$  to  $-6400 \Omega$  for the very thin wire in Fig 2.

Fig 4 shows the impedance for a 100-foot long dipole using really thick, 1.0-inch diameter wire. The reactance varies from  $+1000$  to  $-1500 \Omega$ , indicating once again that a



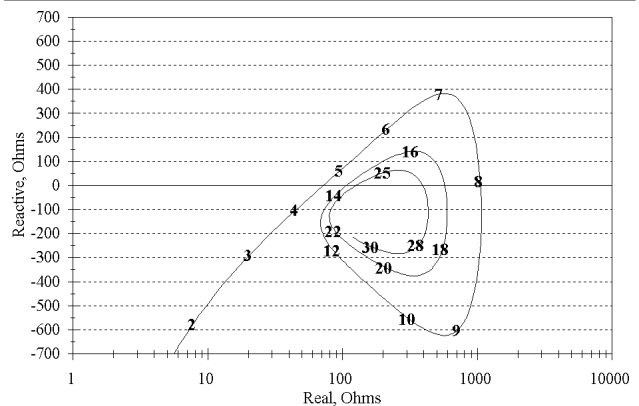
**Fig 4—Feed-point impedance versus frequency for a theoretical 100-foot long dipole, fed in the center, in free space, made of thick 1.0-inch diameter wire. Once again, the excursion in both reactance and resistance over the frequency range is less with this thick wire dipole than with thinner ones.**

larger diameter antenna exhibits less of an excursion in the reactive component with frequency. Note that at the half-wave resonance just below 5 MHz, the resistive component of the impedance is still about  $70 \Omega$ , just about what it is for a much thinner antenna. Unlike the reactance, the half-wave radiation resistance of an antenna doesn't radically change with wire diameter, although the maximum level of resistance at full-wave resonance is lower for thicker antennas.

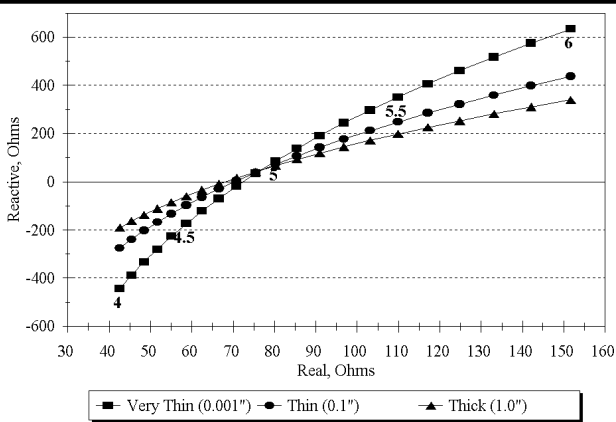
Fig 5 shows the results for a very thick, 10-inch diameter wire. Here, the excursion in the reactive component is even less: about  $+400$  to  $-600 \Omega$ . Note that the full-wave resonant frequency is about 8 MHz for this extremely thick antenna, while thinner antennas have full-wave resonances closer to 9 MHz. Note also that the full-wave resistance for this extremely thick antenna is only about  $1,000 \Omega$ , compared to the  $10,000 \Omega$  shown in Fig 2. All half-wave resonances shown in Figs 2 through 5 remain close to 5 MHz, regardless of the diameter of the antenna wire. Once again, the extremely thick, 10-inch diameter antenna has a resistive component at half-wave resonance close to  $70 \Omega$ . And once again, the change in reactance near this frequency is very much less for the extremely thick antenna than for thinner ones.

Now, we grant you that a 100-foot long antenna made with 10-inch diameter wire sounds a little odd! A length of 100 feet and a diameter of 10 inches represents a ratio of 120:1 in length to diameter. However, this is about the same length-to-diameter ratio as a 432-MHz half-wave dipole using 0.25-inch diameter elements, where the ratio is 109:1. In other words, the ratio of length-to-diameter for the 10-inch diameter, 100-foot long dipole is not that far removed from what is actually used at UHF.

Another way of highlighting the changes in reactance



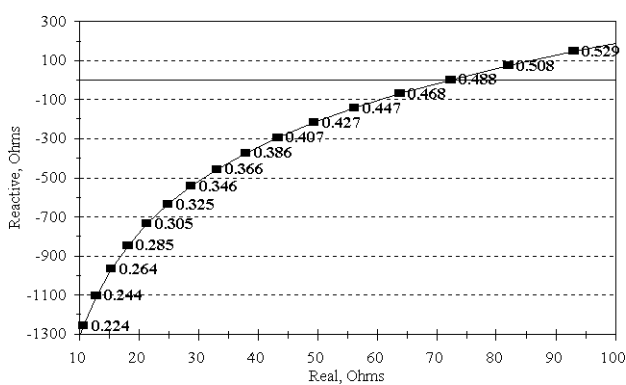
**Fig 5—Feed-point impedance versus frequency for a theoretical 100-foot long dipole, fed in the center, in free space, made of very thick 10.0-inch diameter wire. This ratio of length to diameter is about the same as a typical rod type of dipole element commonly used at 432 MHz. The maximum resistance is now about  $1,000 \Omega$  and the peak reactance range is from about  $-625 \Omega$  to  $+380 \Omega$ . This performance is also found in "cage" dipoles, where a number of paralleled wires are used to simulate a "fat" conductor.**



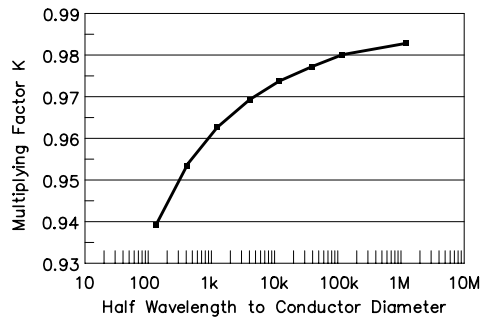
**Fig 6—Expansion of frequency range around half-wave resonant point of three thicknesses of center-fed dipoles. The frequency is noted along the curves in MHz. The slope of change in series reactance versus series resistance is steeper for the thinner antennas than for the thick 1.0-inch antenna, indicating that the Q of the thinner antennas is higher.**

and resistance is shown in **Fig 6**. This shows an expanded portion of the frequency range around the half-wave resonant frequency, from 4 to 6 MHz. In this region, the shape of each spiral curve is almost a straight line. The slope of the curve for the very thin antenna (0.001-inch diameter) is steeper than that for the thicker antennas (0.1 and 1.0-inch diameters). **Fig 7** illustrates another way of looking at the impedance data above and below the half-wave resonance. This is for a 100-foot dipole made of #14 wire. Instead of showing the frequency for each impedance point, the wavelength is shown, making the graph more universal in application.

Just to show that there are lots of ways of looking at



**Fig 7—Another way of looking at the data for a 100-foot, center-fed dipole made of #14 wire in free space. The numbers along the curve represent the fractional wavelength, rather than frequency as shown in Fig 6. Note that this antenna goes through its half-wave resonance about 0.488 λ, rather than exactly at a half-wave physical length.**



**Fig 8—Effect of antenna diameter on length for half-wavelength resonance, shown as a multiplying factor, K, to be applied to the free-space, half-wavelength.**

the same data, **Fig 8** graphs the constant “K” used to multiply the free-space half-wavelength as a function of the ratio between the half-wavelength and the conductor diameter. The curve approaches the value 1.00 for an infinitely thin conductor, in other words an infinitely large ratio of half-wavelength to diameter.

The behavior of antennas with different  $\lambda$ /diameter ratios corresponds to the behavior of ordinary series-resonant circuits having different values of Q. When the Q of a circuit is low, the reactance is small and changes rather slowly as the applied frequency is varied on either side of resonance. If the Q is high, the converse is true. The response curve of the low-Q circuit is *broad*; that of the high-Q circuit *sharp*. So it is with antennas—the impedance of a thick antenna changes slowly over a comparatively wide band of frequencies, while a thin antenna has a faster change in impedance. Antenna Q is defined

$$Q = \frac{f_0 \Delta X}{2R_0 \Delta f} \quad (\text{Eq 3})$$

where  $f_0$  is the center frequency,  $\Delta X$  is the change in the reactance for a  $\Delta f$  change in frequency, and  $R_0$  is the resistance the  $f_0$ . For the “Very Thin,” 0.001-inch diameter dipole in **Fig 2**, a change of frequency from 5.0 to 5.5 MHz yields a reactance change from 86 to 351 Ω, with an  $R_0$  of 95 Ω. The Q is thus 14.6. For the 1.0-inch-diameter “Thick” dipole in **Fig 4**,  $\Delta X = 131 \Omega$  and  $R_0$  is still 95 Ω, making  $Q = 7.2$  for the thicker antenna, roughly half that of the thinner antenna.

Let’s recap. We have described an antenna first as a transducer, then as a sort of transformer to the free-space impedance. Now, we just compared the antenna to a series-tuned circuit. Near its half-wave resonant frequency, a center-fed  $\lambda/2$  dipole exhibits much the same characteristics as a conventional series-resonant circuit. Exactly at resonance, the current at the input terminals is in phase with the applied voltage and the feed-point impedance is purely resistive. If the frequency is below resonance, the phase of the current leads the voltage; that is, the reactance of the antenna is

capacitive. When the frequency is above resonance, the opposite occurs; the current lags the applied voltage and the antenna exhibits inductive reactance. Just like a conventional series-tuned circuit, the antenna's reactance and resistance determines its Q.

## ANTENNA DIRECTIVITY AND GAIN

### The Isotropic Radiator

Before we can fully describe practical antennas, we must first introduce a completely theoretical antenna, the *isotropic radiator*. Envision, if you will, an infinitely small antenna, a point located in outer space, completely removed from anything else around it. Then consider an infinitely small transmitter feeding this infinitely small, point antenna. You now have an isotropic radiator.

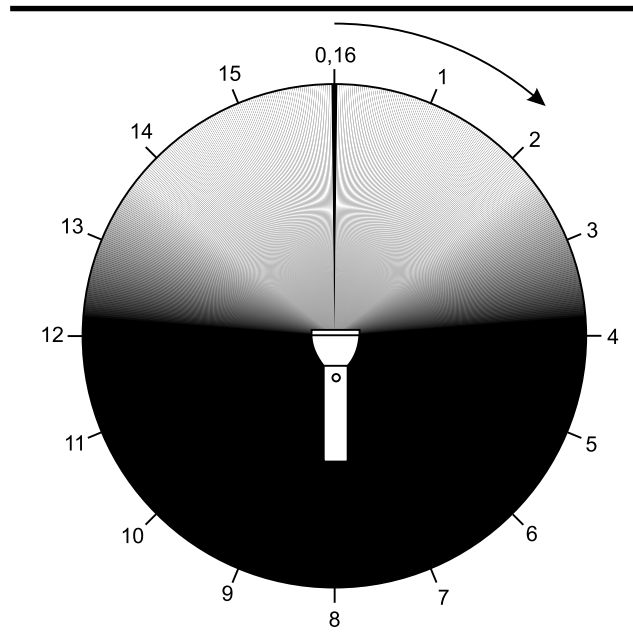
The uniquely useful property of this theoretical *point-source* antenna is that it radiates equally well in all directions. That is to say, an isotropic antenna favors no direction at the expense of any other—in other words, it has absolutely no *directivity*. The isotropic radiator is useful as a “measuring stick” for comparison with actual antenna systems.

You will find later that real, practical antennas all exhibit some degree of directivity, which is the property of radiating more strongly in some directions than in others. The radiation from a practical antenna never has the same intensity in all directions and may even have zero radiation in some directions. The fact that a practical antenna displays directivity (while an isotropic radiator does not) is not necessarily a bad thing. The directivity of a real antenna is often carefully tailored to emphasize radiation in particular directions. For example, a receiving antenna that favors certain directions can discriminate against interference or noise coming from other directions, thereby increasing the signal-to-noise ratio for desired signals coming from the favored direction.

### Directivity and the Radiation Pattern— a Flashlight Analogy

The directivity of an antenna is directly related to the *pattern* of its radiated field intensity in free space. A graph showing the actual or relative field intensity at a fixed distance, as a function of the direction from the antenna system, is called a *radiation pattern*. Since we can't actually see electromagnetic waves making up the radiation pattern of an antenna, we can consider an analogous situation.

**Fig 9** represents a flashlight shining in a totally darkened room. To quantify what our eyes are seeing, we use a sensitive light meter like those used by photographers, with a scale graduated in units from 0 to 10. We place the meter directly in front of the flashlight and adjust the distance so the meter reads 10, exactly full scale. We also carefully note the distance. Then, always keeping the meter the same distance from the flashlight and keeping it at the same height above the floor, we move the light meter around the flashlight, as indicated by the arrow, and take light readings at a number of different positions.



**Fig 9**—The beam from a flashlight illuminates a totally darkened area as shown here. Readings taken with a photographic light meter at the 16 points around the circle may be used to plot the radiation pattern of the flashlight.

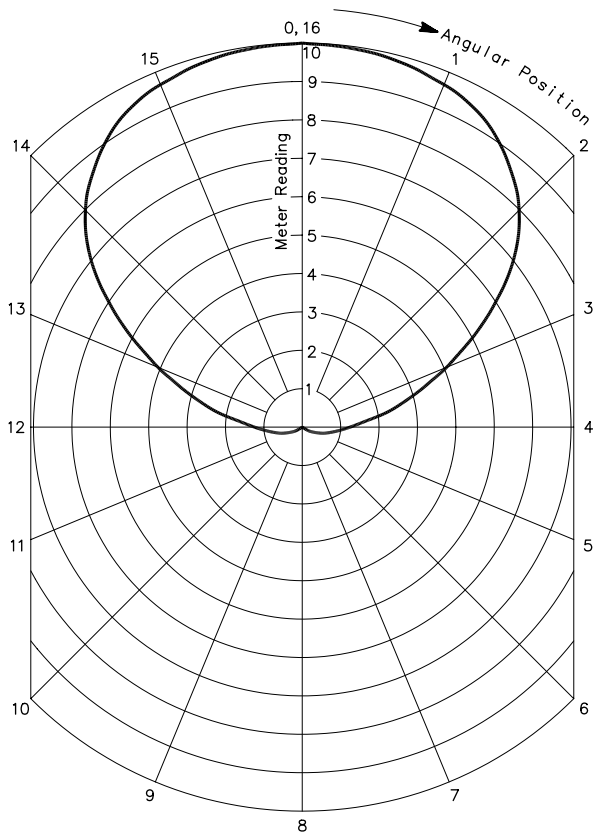
After all the readings have been taken and recorded, we plot those values on a sheet of polar graph paper, like that shown in **Fig 10**. The values read on the meter are plotted at an angular position corresponding to that for which each meter reading was taken. Following this, we connect the plotted points with a smooth curve, also shown in **Fig 10**. When this is finished, we have completed a radiation pattern for the flashlight.

### Antenna Pattern Measurements

Antenna radiation patterns can be constructed in a similar manner. Power is fed to the antenna under test, and a field-strength meter indicates the amount of signal. We might wish to rotate the antenna under test, rather than moving the measuring equipment to numerous positions about the antenna. Or we might make use of antenna reciprocity, since the pattern while receiving is the same as that while transmitting. A source antenna fed by a low-power transmitter illuminates the antenna under test, and the signal intercepted by the antenna under test is fed to a receiver and measuring equipment. Additional information on the mechanics of measuring antenna patterns is contained in **Chapter 27**.

Some precautions must be taken to assure that the measurements are accurate and repeatable. In the case of the flashlight, let's assume that the separation between the light source and the light meter is 2 meters, about 6.5 feet. The wavelength of visible light is about one-half micron,





**Fig 10—The radiation pattern of the flashlight in Fig 9. The measured values are plotted and connected with a smooth curve.**

where a micron is one-millionth of a meter.

For the flashlight, a separation of 2 meters between source and detector is  $2.0 / (0.5 \times 10^{-6}) = 4$  million  $\lambda$ , a very large number of wavelengths. Measurements of practical HF or even VHF antennas are made at much closer distances, in terms of wavelength. For example, at 3.5 MHz a full wavelength is 85.7 meters, or 281.0 feet. To duplicate the flashlight-to-light-meter spacing in wavelengths at 3.5 MHz, we would have to place the field-strength measuring instrument almost on the surface of the Moon, about a quarter-million miles away!

### The Fields Around an Antenna

Why should we be concerned with the separation between the source antenna and the field-strength meter, which has its own receiving antenna? One important reason is that if you place a receiving antenna very close to an antenna whose pattern you wish to measure, mutual coupling between the two antennas may actually alter the pattern you are trying to measure.

This sort of mutual coupling can occur in the region very close to the antenna under test. This region is called the *reactive near-field* region. The term “reactive” refers to the fact that the mutual impedance between the transmitting

and receiving antennas can be either capacitive or inductive in nature. The reactive near field is sometimes called the “induction field,” meaning that the magnetic field usually is predominant over the electric field in this region. The antenna acts as though it were a rather large, lumped-constant inductor or capacitor, storing energy in the reactive near field rather than propagating it into space.

For simple wire antennas, the reactive near field is considered to be within about a half wavelength from an antenna’s radiating center. Later on, in the chapters dealing with **Yagi** and **quad antennas**, you will find that mutual coupling between elements can be put to good use to purposely shape the radiated pattern. For making pattern measurements, however, we do not want to be too close to the antenna being measured.

The strength of the reactive near field decreases in a complicated fashion as you increase the distance from the antenna. Beyond the reactive near field, the antenna’s radiated field is divided into two other regions: the *radiating near field* and the *radiating far field*. Historically, the terms *Fresnel* and *Fraunhofer* fields have been used for the radiating near and far fields, but these terms have been largely supplanted by the more descriptive terminology used here. Even inside the reactive near-field region, both radiating and reactive fields coexist, although the reactive field predominates very close to the antenna.

Because the boundary between the fields is rather “fuzzy,” experts debate where one field begins and another leaves off, but the boundary between the radiating near and far fields is generally accepted as:

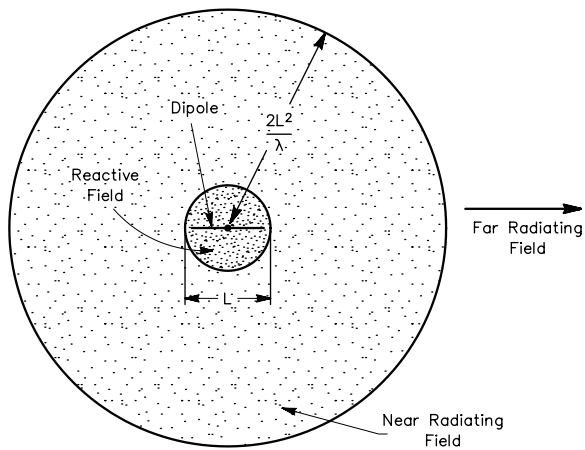
$$D \approx \frac{2L^2}{\lambda} \quad (\text{Eq 4})$$

where L is the largest dimension of the physical antenna, expressed in the same units of measurement as the wavelength  $\lambda$ . Remember, many specialized antennas do not follow the rule of thumb in Eq 4 exactly. **Fig 11** depicts the three fields in front of a simple wire antenna.

Throughout the rest of this book we will discuss mainly the radiating far-fields, those forming the traveling electromagnetic waves. Far-field radiation is distinguished by the fact that the intensity is inversely proportional to the distance, and that the electric and magnetic components, although perpendicular to each other in the wave front, are in time phase. The total energy is equally divided between the electric and magnetic fields. Beyond several wavelengths from the antenna, these are the only fields we need to consider. For accurate measurement of radiation patterns, we must place our measuring instrumentation at least several wavelengths away from the antenna under test.

### Pattern Planes

Patterns obtained above represent the antenna radiation in just one plane. In the example of the flashlight, the plane of measurement was at one height above the floor. Actually, the pattern for any antenna is three dimensional, and therefore



**Fig 11**—The fields around a radiating antenna. Very close to the antenna, the reactive field dominates. Within this area mutual impedances are observed between antenna and any other antennas used to measure response. Outside of the reactive field, the near radiating field dominates, up to a distance approximately equal to  $2L^2/\lambda$ , where  $L$  is the length of the largest dimension of the antenna. Beyond the near/far field boundary lies the far radiating field, where power density varies as the inverse square of radial distance.

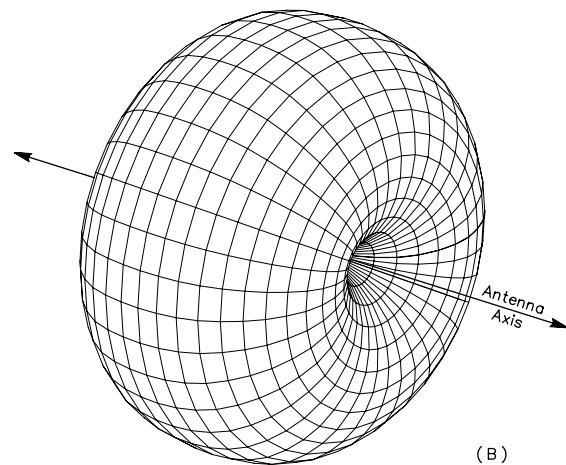
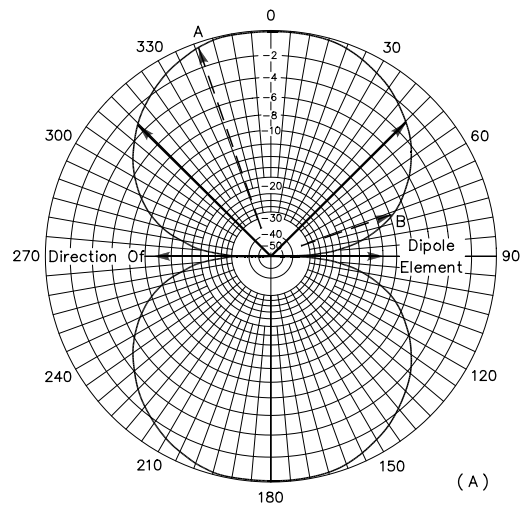
cannot be represented in a single-plane drawing. The “solid” radiation pattern of an antenna in free space would be found by measuring the field strength at every point on the surface of an imaginary sphere having the antenna at its center. The information so obtained would then be used to construct a solid figure, where the distance from a fixed point (representing the antenna) to the surface of the figure is proportional to the field strength from the antenna in any given direction. **Fig 12B** shows a three-dimensional wire-grid representation of the radiation pattern of a half-wave dipole.

For amateur work, *relative* values of field strength (rather than absolute) are quite adequate in pattern plotting. In other words, it is not necessary to know how many microvolts per meter a particular antenna will produce at a distance of 1 mile when excited with a specified power level. (This is the kind of specifications that AM broadcast stations must meet to certify their antenna systems to the FCC.)

For whatever data is collected (or calculated from theoretical equations), it is common to normalize the plotted values so the field strength in the direction of maximum radiation coincides with the outer edge of the chart. On a given system of polar coordinate scales, the *shape* of the pattern is not altered by proper normalization, only its size.

### E and H-Plane Patterns

The solid 3-D pattern of an antenna in free space cannot adequately be shown with field-strength data on a flat sheet of paper. Cartographers making maps of a round Earth on



**Fig 12**—Directive diagram of a free-space dipole. At A, the pattern in the plane containing the wire axis. The length of each dashed-line arrow represents the relative field strength in that direction, referenced to the direction of maximum radiation, which is at right angles to the wire’s axis. The arrows at approximately  $45^\circ$  and  $315^\circ$  are the half-power or  $-3$  dB points. At B, a wire grid representation of the “solid pattern” for the same antenna. These same patterns apply to any center-fed dipole antenna less than a half wavelength long.

flat pieces of paper face much the same kind of problem. As we discussed above, cross-sectional or plane diagrams are very useful for this purpose. Two such diagrams, one in the plane containing the straight wire of a dipole and one in the plane perpendicular to the wire, can convey a great deal of information. The pattern in the plane containing the axis of the antenna is called the *E-plane pattern*, and the one in the plane perpendicular to the axis is called the *H-plane pattern*. These designations are used because they represent the planes in which the electric (symbol E), and the magnetic (symbol H) lines of force lie, respectively.

The E lines represent the *polarization* of the antenna.

## Introduction to the Decibel

The power gain of an antenna system is usually expressed in *decibels*. The decibel is a practical unit for measuring power ratios because it is more closely related to the actual effect produced at a distant receiver than the power ratio itself. One decibel represents a just-detectable change in signal strength, regardless of the actual value of the signal voltage. A 20-decibel (20-dB) increase in signal, for example, represents 20 observable “steps” in increased signal. The power ratio (100 to 1) corresponding to 20 dB gives an entirely exaggerated idea of the improvement in communication to be expected. The number of decibels corresponding to any power ratio is equal to 10 times the common logarithm of the power ratio, or

$$\text{dB} = 10 \log_{10} \frac{P_1}{P_2}$$

If the voltage ratio is given, the number of decibels is equal to 20 times the common logarithm of the ratio. That is,

$$\text{dB} = 20 \log_{10} \frac{V_1}{V_2}$$

When a *voltage* ratio is used, both voltages must be measured across the same value of impedance. Unless this is done the decibel figure is meaningless, because it is fundamentally a measure of a *power* ratio.

The main reason a decibel is used is that successive power gains expressed in decibels may simply be added together. Thus a gain of 3 dB followed by a gain of 6 dB gives a total gain of 9 dB. In ordinary power ratios, the ratios must be multiplied together to find the total gain.

A *reduction* in power is handled simply by subtracting the requisite number of decibels. Thus, reducing the power to  $1/2$  is the same as *subtracting* 3 decibels. For example, a power gain of 4 in one part of a system and a reduction to  $1/2$  in another part gives a total power gain of  $4 \times 1/2 = 2$ . In decibels, this is  $6 - 3 = 3$  dB. A power reduction or “loss” is simply indicated by including a negative sign in front of the appropriate number of decibels.

Polarization will be covered in more detail later in this chapter. The electromagnetic field pictured in [Fig 1 of Chapter 23](#), as an example, is the field that would be radiated from a vertically polarized antenna; that is, an antenna in which the conductor is mounted perpendicular to the earth.

When a radiation pattern is shown for an antenna mounted over ground rather than in free space, two frames of reference are automatically gained—an *azimuth angle* and an *elevation angle*. The azimuth angle is usually referenced to the maximum radiation lobe of the antenna, where the

azimuth angle is defined at  $0^\circ$ , or it could be referenced to the Earth’s True North direction for an antenna oriented in a particular compass direction. The E-plane pattern for an antenna over ground is now called the *azimuth pattern*.

The elevation angle is referenced to the horizon at the Earth’s surface, where the elevation angle is  $0^\circ$ . Of course, the Earth is round but because its radius is so large, it can in this context be considered to be flat in the area directly under the antenna. An elevation angle of  $90^\circ$  is straight over the antenna, and a  $180^\circ$  elevation is toward the horizon directly behind the antenna.

Professional antenna engineers often describe an antenna’s orientation with respect to the point directly overhead—using the *zenith angle*, rather than the elevation angle. The elevation angle is computed by subtracting the zenith angle from  $90^\circ$ .

Referenced to the horizon of the Earth, the H-plane pattern is now called the *elevation pattern*. Unlike the free-space H-plane pattern, the over-ground elevation pattern is drawn as a half-circle, representing only positive elevations above the Earth’s surface. The ground reflects or blocks radiation at negative elevation angles, making below-surface radiation plots unnecessary.

After a little practice, and with the exercise of some imagination, the complete solid pattern can be visualized with fair accuracy from inspection of the two planar diagrams, provided of course that the solid pattern of the antenna is “smooth,” a condition that is true for simple antennas like  $\lambda/2$  dipoles.

Plane diagrams are plotted on polar coordinate paper, as described earlier. The points on the pattern where the radiation is zero are called *nulls*. The curved section from one null to the next on the plane diagram, or the corresponding section on the solid pattern, is called a *lobe*. The strongest lobe is commonly called the *main lobe*. [Fig 12A](#) shows the E-plane pattern for a half-wave dipole. In [Fig 12](#), the dipole is placed in free space. In addition to the labels showing the main lobe and nulls in the pattern, the so-called *half-power* points on the main lobe are shown. These are the points where the power is 3 dB down from the peak value in the main lobe.

## Directivity and Gain

Let us now examine directivity more closely. As mentioned previously, all practical antennas, even the simplest types, exhibit directivity. Free-space directivity can be expressed quantitatively by comparing the three-dimensional pattern of the antenna under consideration with the perfectly spherical three-dimensional pattern of an isotropic antenna. The field strength (and thus power per unit area, or “power density”) are the same everywhere on the surface of an imaginary sphere having a radius of many wavelengths and having an isotropic antenna at its center. At the surface of the same imaginary sphere around an antenna radiating the same total power, the directive pattern results in greater power density at some points on this sphere and less at others. The ratio of the maximum power density

to the average power density taken over the entire sphere (which is the same as from the isotropic antenna under the specified conditions) is the numerical measure of the directivity of the antenna. That is,

$$D = \frac{P}{P_{av}} \quad (\text{Eq 5})$$

where

D = directivity

P = power density at its maximum point on the surface of the sphere

$P_{av}$  = average power density

The *gain* of an antenna is closely related to its directivity. Because directivity is based solely on the *shape* of the directive pattern, it does not take into account any power losses that may occur in an actual antenna system. To determine gain, these losses must be subtracted from the power supplied to the antenna. The loss is normally a constant percentage of the power input, so the antenna gain is

$$G = k \frac{P}{P_{av}} = kD \quad (\text{Eq 6})$$

where

G = gain (expressed as a power ratio)

D = directivity

k = efficiency (power radiated divided by power input) of the antenna

P and  $P_{av}$  are as above

For many of the antenna systems used by amateurs, the efficiency is quite high (the loss amounts to only a few percent of the total). In such cases the gain is essentially equal to the directivity. The more the directive diagram is compressed—or, in common terminology, the “sharper” the lobes—the greater the power gain of the antenna. This is a natural consequence of the fact that as power is taken away from a larger and larger portion of the sphere surrounding the radiator, it is added to the volume represented by the narrow lobes. Power is therefore concentrated in some directions, *at the expense of others*. In a general way, the smaller the volume of the solid radiation pattern, compared with the volume of a sphere having the same radius as the length of the largest lobe in the actual pattern, the greater the power gain.

As stated above, the gain of an antenna is related to its directivity, and directivity is related to the shape of the directive pattern. A commonly used index of directivity, and therefore the gain of an antenna, is a measure of the width of the major lobe (or lobes) of the plotted pattern. The width is expressed in degrees at the half-power or  $-3$  dB points, and is often called the *beamwidth*.

This information provides only a general idea of relative gain, rather than an exact measure. This is because an absolute measure involves knowing the power density at every point on the surface of a sphere, while a single diagram shows the pattern shape in only one plane of that sphere. It is customary to examine at least the E-plane and the H-plane

patterns before making any comparisons between antennas.

A simple approximation for gain over an isotropic radiator can be used, but only if the sidelobes in the antenna’s pattern are small compared to the main lobe and if the resistive losses in the antenna are small. When the radiation pattern is complex, numerical integration is employed to give the actual gain.

$$G \approx \frac{41253}{H_{3dB} \times E_{3dB}} \quad (\text{Eq 7})$$

where  $H_{3dB}$  and  $E_{3dB}$  are the half-power points, in degrees, for the H and E-plane patterns.

### Radiation Patterns for Center-Fed Dipoles at Different Frequencies

Earlier, we saw how the feed-point impedance of a fixed-length center-fed dipole in free space varies as the frequency is changed. What happens to the radiation pattern of such an antenna as the frequency is changed?

In general, the greater the length of a center-fed antenna, in terms of wavelength, the larger the number of lobes into which the pattern splits. A feature of all such patterns is the fact that the main lobe—the one that gives the largest field strength at a given distance—always is the one that makes the smallest angle with the antenna wire. Furthermore, this angle becomes smaller as the length of the antenna is increased.

Let’s examine how the free-space radiation pattern changes for a 100-foot long wire made of #14 wire as the frequency is varied. (Varying the frequency effectively changes the wavelength for a fixed-length wire.) **Fig 13** shows the E-plane pattern at the  $\lambda/2$  resonant frequency of 4.8 MHz. This is a classical dipole pattern, with a gain in free space of 2.14 dBi referenced to an isotropic radiator.

**Fig 14** shows the free-space E-plane pattern for the same antenna, but now at the full-wave ( $2\lambda/2$ ) resonant frequency of 9.55 MHz. Note how the pattern has been “pinched in” at the top and bottom of the figure. In other words, the two main lobes have become sharper at this frequency, making the gain 3.73 dBi, higher than at the  $\lambda/2$  frequency.

**Fig 15** shows the pattern at the  $3\lambda/2$  frequency of

#### Coordinate Scales for Radiation Patterns

A number of different systems of coordinate scales or “grids” are in use for plotting antenna patterns. Antenna patterns published for amateur audiences are sometimes placed on rectangular grids, but more often they are shown using polar coordinate systems. Polar coordinate systems may be divided generally into three classes: linear, logarithmic, and modified logarithmic.

A very important point to remember is that the shape of a pattern (its general appearance) is highly dependent on the grid system used for the plotting. This is exemplified in **Fig A—(A)**, where the radiation pattern for a beam antenna is presented using three coordinate systems discussed in the paragraphs that follow.

### Linear Coordinate Systems

The polar coordinate system for the flashlight radiation pattern, Fig 10, uses linear coordinates. The concentric circles are equally spaced, and are graduated from 0 to 10. Such a grid may be used to prepare a linear plot of the power contained in the signal. For ease of comparison, the equally spaced concentric circles have been replaced with appropriately placed circles representing the decibel response, referenced to 0 dB at the outer edge of the plot. In these plots the minor lobes are suppressed. Lobes with peaks more than 15 dB or so below the main lobe disappear completely because of their small size. This is a good way to show the pattern of an array having high directivity and small minor lobes.

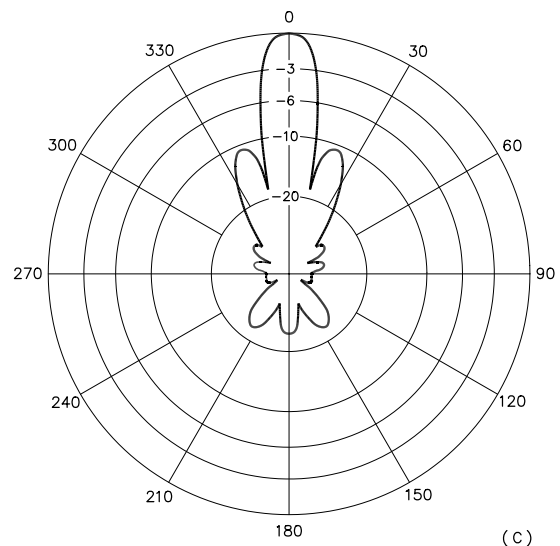
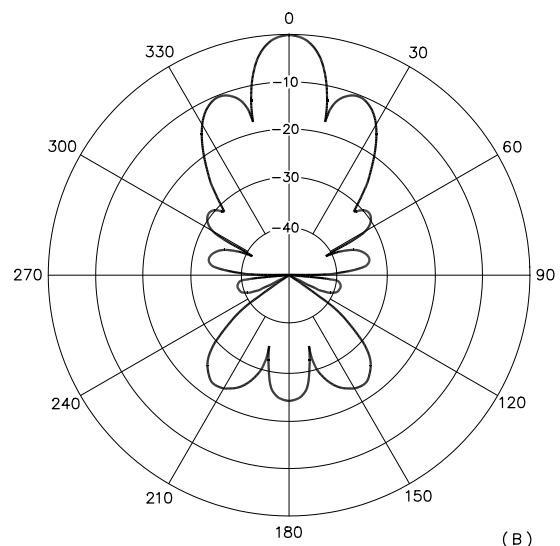
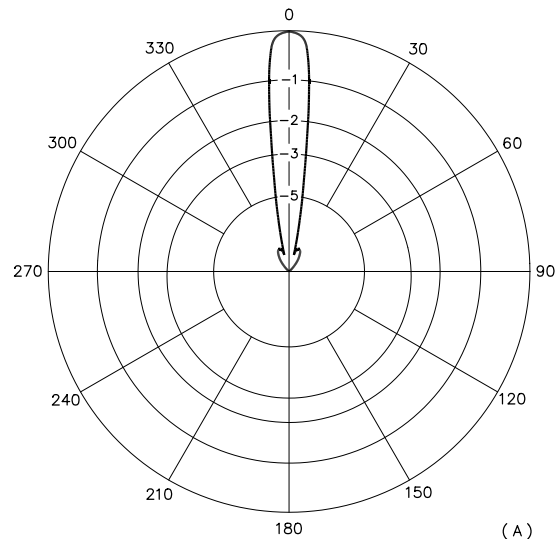
### Logarithmic Coordinate System

Another coordinate system used by antenna manufacturers is the logarithmic grid, where the concentric grid lines are spaced according to the logarithm of the voltage in the signal. If the logarithmically spaced concentric circles are replaced with appropriately placed circles representing the decibel response, the decibel circles are graduated linearly. In that sense, the logarithmic grid might be termed a linear-log grid, one having linear divisions calibrated in decibels.

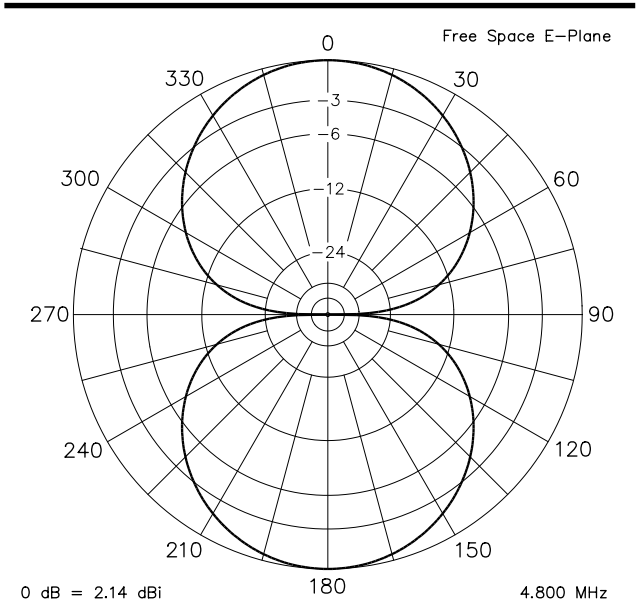
This grid enhances the appearance of the minor lobes. If the intent is to show the radiation pattern of an array supposedly having an omnidirectional response, this grid enhances that appearance. An antenna having a difference of 8 or 10 dB in pattern response around the compass appears to be closer to omnidirectional on this grid than on any of the others. See Fig A—(B).

### ARRL Log Coordinate System

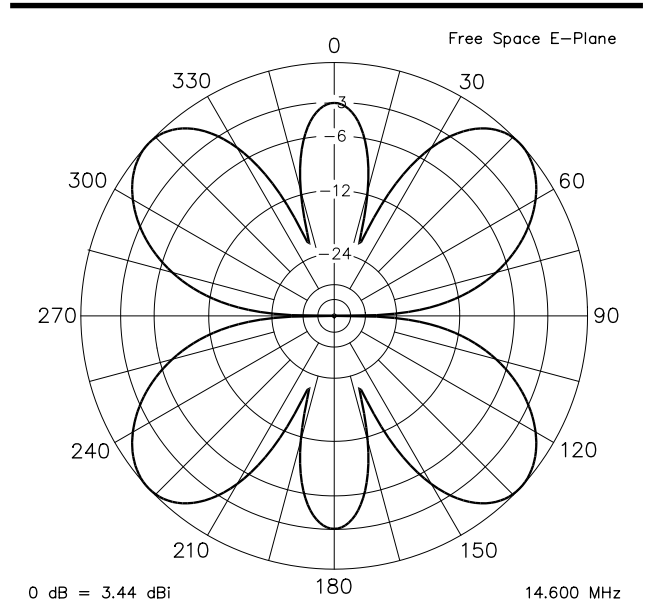
The modified logarithmic grid used by the ARRL has a system of concentric grid lines spaced according to the logarithm of 0.89 times the value of the signal voltage. In this grid, minor lobes that are 30 and 40 dB down from the main lobe are distinguishable. Such lobes are of concern in VHF and UHF work. The spacing between plotted points at 0 dB and -3 dB is significantly greater than the spacing between -20 and -23 dB, which in turn is significantly greater than the spacing between -50 and -53 dB. The spacings thus correspond generally to the relative significance of such changes in antenna performance. Antenna pattern plots in this publication are made on the modified-log grid similar to that shown in Fig A—(C).



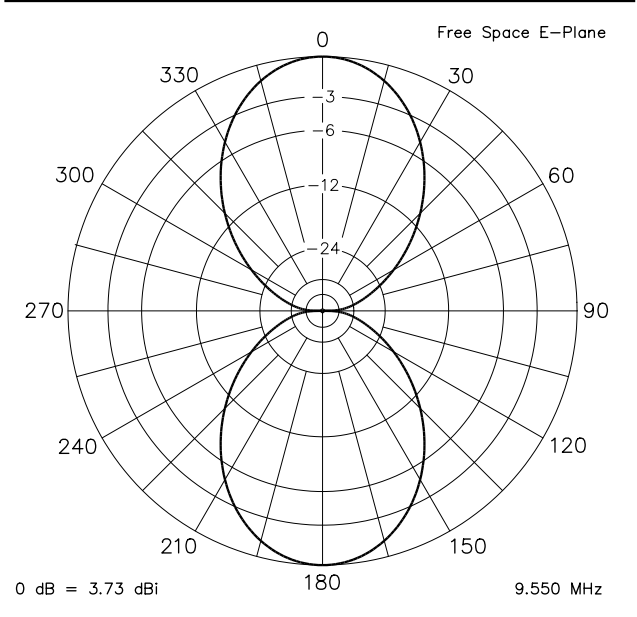
**Fig A—Radiation pattern plots for a beam antenna on three different grid coordinate systems. At A, the pattern on a linear-power dB grid. Notice how details of sidelobe structure are lost with this grid. At B, the same pattern on a grid with constant 10 dB circles. The sidelobe level is exaggerated when this scale is employed. At C, the same pattern on the modified log grid used by ARRL. The side and rearward lobes are clearly visible on this grid. The concentric circles in all three grids are graduated in decibels referenced to 0 dB at the outer edge of the chart. The patterns look quite different, yet they all represent the same antenna response!**



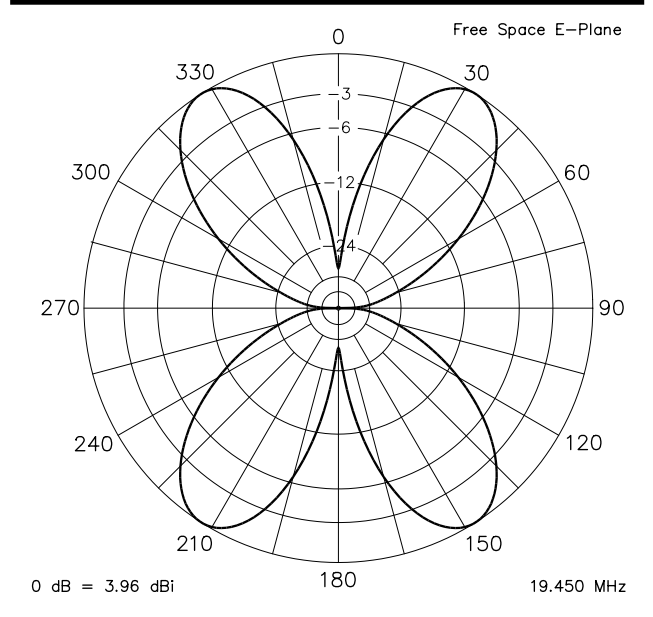
**Fig 13—Free-space E-Plane radiation pattern for a 100-foot dipole at its half-wave resonant frequency of 4.80 MHz. This antenna has 2.14 dBi gain. The dipole is located on the line from 90° to 270°.**



**Fig 15—Free-space E-Plane radiation pattern for a 100-foot dipole at its 3/2 λ resonant frequency of 14.60 MHz. The pattern has broken up into six lobes, and thus the peak gain is down to 3.44 dBi.**



**Fig 14—Free-space E-Plane radiation pattern for a 100-foot dipole at its full-wave resonant frequency of 9.55 MHz. The gain has increased to 3.73 dBi, because the main lobes have been focused and sharpened compared to Fig 13.**



**Fig 16—Free-space E-Plane radiation pattern for a 100-foot dipole at its twice full-wave resonant frequency of 19.45 MHz. The pattern has been refocused into four lobes, with a peak gain of 3.96 dBi.**

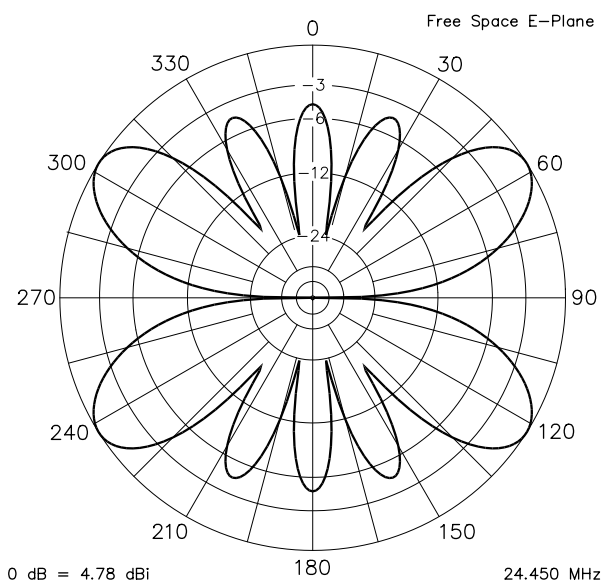
14.6 MHz. More lobes have developed compared to Fig 14. This means that the power has split up into more lobes and consequently the gain decreases a small amount, down to 3.44 dBi. This is still higher than the dipole at its  $\lambda/2$  frequency, but lower than at its full-wave frequency. **Fig 16** shows the E-plane response at 19.45 MHz, the  $4\lambda/2$ , or  $2\lambda$ ,

resonant frequency. Now the pattern has re-formed itself into only four lobes, and the gain has as a consequence risen to 3.96 dBi.

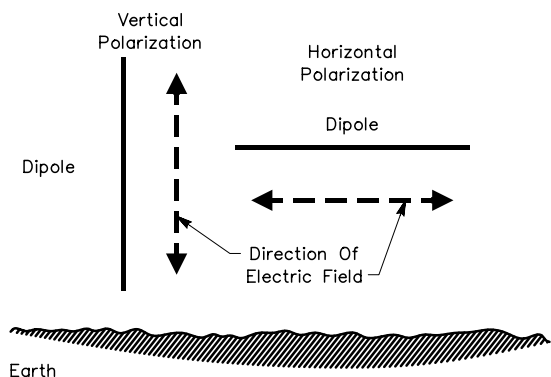
In **Fig 17** the response has become quite complex at the  $5\lambda/2$  resonance point of 24.45 MHz, with ten lobes showing. Despite the presence all these lobes, the main lobes now show

a gain of 4.78 dBi. Finally, **Fig 18** shows the pattern at the  $3\lambda$  ( $6\lambda/2$ ) resonance at 29.45 MHz. Despite the fact that there are fewer lobes taking up power than at 24.45 MHz, the peak gain is slightly less at 29.45 MHz, at 4.70 dBi.

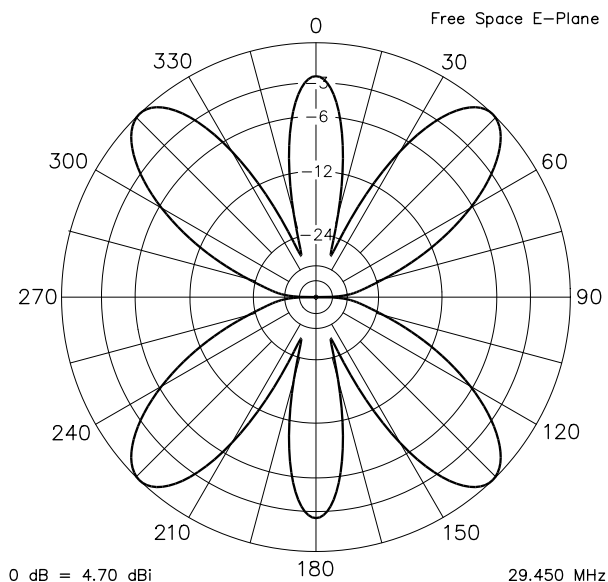
The pattern—and hence the gain—of a fixed-length antenna varies considerably as the frequency is changed. Of course, the pattern and gain change in the same fashion if the frequency is kept constant and the length of the wire is varied. In either case, the wavelength is changing. It is also evident that certain lengths reinforce the pattern to provide more peak gain. If an antenna is not rotated in azimuth when the frequency is changed, the peak gain may occur in a



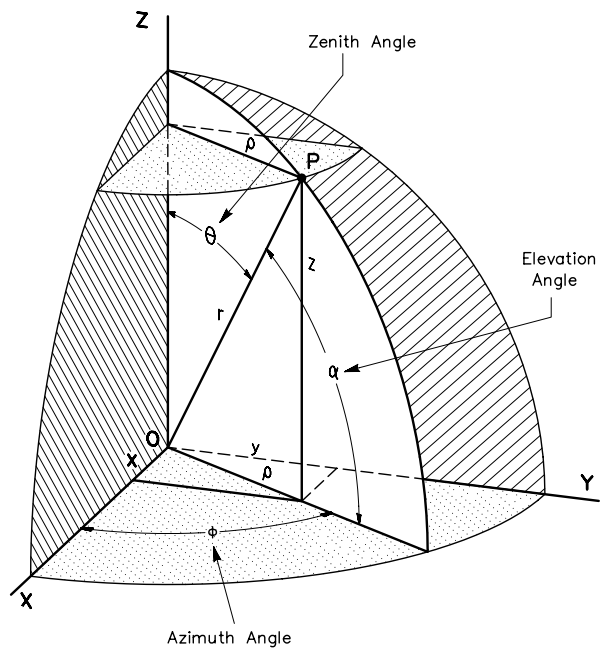
**Fig 17**—Free-space E-Plane radiation pattern for a 100-foot dipole at its  $5/2 \lambda$  resonant frequency of 24.45 MHz. The pattern has broken down into eight lobes, with a peak gain of 4.78 dBi.



**Fig 19**—Vertical and horizontal polarization of a dipole above ground. The direction of polarization is the direction of the maximum electric field with respect to the earth.



**Fig 18**—Free-space E-Plane radiation pattern for a 100-foot dipole at its three-times full-wave resonant frequency of 29.45 MHz. The pattern has come back to six lobes, with a peak gain of 4.70 dBi.



**Fig 20**—Diagram showing polar representation of a point P lying on an imaginary sphere surround a point-source antenna. The various angles associated with this coordinate system are shown referenced to the x, y and z-axes.

different direction than you might like. In other words, the main lobes change direction as the frequency is varied.

## POLARIZATION

We've now examined the first two of the three major properties used to characterize antennas: the radiation pattern and the feed-point impedance. The third general property is *polarization*. An antenna's polarization is defined to be that of its electric field, in the direction where the field strength is maximum.

For example, if a  $\lambda/2$  dipole is mounted horizontally over the Earth, the electric field is strongest perpendicular to its axis (that is, at right angle to the wire) and parallel to the earth. Thus, since the maximum electric field is

horizontal, the polarization in this case is also considered to be *horizontal* with respect to the earth. If the dipole is mounted vertically, its polarization will be *vertical*. See [Fig 19](#). Note that if an antenna is mounted in free space, there is no frame of reference and hence its polarization is indeterminate.

Antennas composed of a number of  $\lambda/2$  elements arranged so that their axes lie in the same or parallel directions have the same polarization as that of any one of the elements. For example, a system composed of a group of horizontal dipoles is horizontally polarized. If both horizontal and vertical elements are used in the same plane and radiate in phase, however, the polarization is the *resultant* of the contributions made by each set of elements to the

### Antenna Analysis by Computer

With the proliferation of personal computers since the early 1980s, significant strides in computerized antenna system analysis have been made. It is now possible for the amateur with a relatively inexpensive computer to evaluate even complicated antenna systems. Amateurs can obtain a greater grasp of the operation of antenna systems—a subject that has been a great mystery to many in the past.

The most commonly encountered programs for antenna analysis are those derived from a program developed at US government laboratories called *NEC*, short for “Numerical Electromagnetics Code.” *NEC* uses a “Method of Moments” algorithm. The mathematics behind this algorithm are pretty formidable to most hams, but the basic principle is simple. In essence, an antenna is broken down into a number of straight-line wire “segments,” and the field resulting from the RF current in each segment is evaluated by itself and also with respect to other mutually coupled segments. Finally, the field from each contributing segment is vector-summed together to yield the total field, which can be computed for any elevation or azimuth angle desired. The effects of flat-earth ground reflections, including the effect of ground conductivity and dielectric constant, may be evaluated as well.

In the early 1980s, *MININEC* was written in BASIC for use on personal computers. Because of limitations in memory and speed typical of personal computers of the time, several simplifying assumptions were necessary in *MININEC*, which limited potential accuracy. Perhaps the most significant limitation was that “perfect ground” was assumed to be directly under the antenna, even though the radiation pattern in the far field did take into account real ground parameters. This meant that antennas modeled closer than approximately  $0.2 \lambda$  over ground sometimes gave erroneous impedances and inflated gains, especially for horizontal polarization. Despite some limitations, *MININEC* represented a remarkable leap forward in analytical capability. See Roy Lewallen's “*MININEC*—the Other Edge of the Sword” in Feb 1991 *QST* for an excellent treatment on pitfalls when using *MININEC*.

Because source code was made available when

*MININEC* was released to the public, a number of programmers have produced some very capable versions for the amateur market, many incorporating exciting graphics showing antenna patterns in 2D or 3D. These programs also simplify the creation of models for popular antenna types, and several come with libraries of sample antennas.

By the end of the 1980s, the speed and capabilities of personal computers had advanced to the point where PC versions of *NEC* became practical, and several versions are now available to amateurs. Like *MININEC*, *NEC* is a general-purpose modeling package, and it can be difficult to use and relatively slow in operation for certain specialized antenna forms. Thus, custom software has been created for quick and accurate analysis of specific antenna varieties, mainly Yagi arrays. See [Chapter 11](#).

The most difficult part of using a *NEC*-type of modeling program is setting up the antenna's geometry—you must condition yourself to think in three-dimensional coordinates. Each end point of a wire is represented by three numbers: an x, y and z coordinate. An example should help sort things out. See [Fig D](#), showing a “model” for a 135-foot center-fed dipole, made of #14 wire placed 50 feet above flat ground. This antenna is modeled as a single, straight wire.

For convenience, the ground is located at the *origin* of the coordinate system, at (0, 0, 0) feet, directly under the center of the dipole. Above the origin, at a height of 50 feet, is the dipole's feedpoint. The “wing-spread” of the dipole goes toward the left (that is, in the “negative y” direction) one-half the overall length, or -67.5 feet. Toward the right, it goes +67.5 feet. The “x” dimension of our dipole is zero. The dipole's ends are thus represented by two points, whose coordinates are: (0, -67.5, 50) and (0, 67.5, 50) feet. The thickness of the antenna is the diameter of the wire, #14 gauge.

Now, another nasty little detail surfaces—you must specify the number of segments into which the dipole is divided for the method-of-moment analysis. The guideline for setting the number of segments is to use at least 10 segments per half-wavelength. In [Fig D](#),



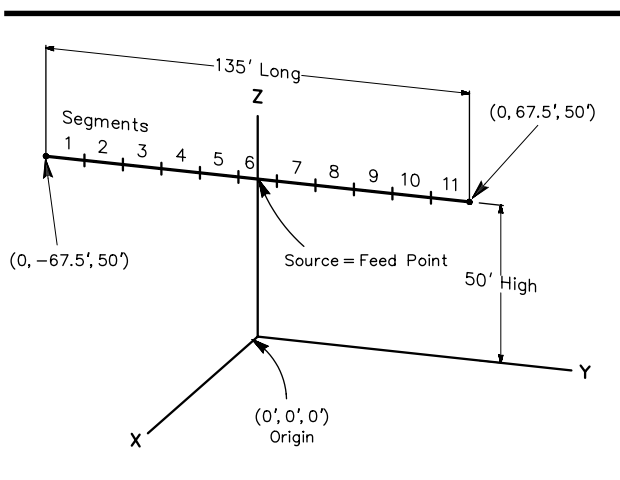
total electromagnetic field at a given point some distance from the antenna. In such a case the resultant polarization is still *linear*, but is tilted between horizontal and vertical.

In directions other than those where the radiation is maximum, the resultant wave even for a simple dipole is a combination of horizontally and vertically polarized components. The radiation off the ends of a horizontal dipole is actually vertically polarized, albeit at a greatly reduced amplitude compared to the broadside horizontally polarized radiation—the sense of polarization changes with compass direction.

Thus it is often helpful to consider the radiation pattern from an antenna in terms of polar coordinates, rather than trying to think in purely linear horizontal or vertical

coordinates. See [Fig 20](#). The reference axis in a polar system is vertical to the earth under the antenna. The zenith angle is usually referred to as  $\theta$  (Greek letter theta), and the azimuth angle is referred to as  $\phi$  (Greek letter phi). Instead of zenith angles, most amateurs are more familiar with *elevation angles*, where a zenith angle of  $0^\circ$  is the same as an elevation angle of  $90^\circ$ , straight overhead. Native *NEC* or *MININEC* computer programs use zenith angles rather than elevation angles, although most commercial versions automatically reduce these to elevation angles.

If vertical and horizontal elements in the same plane are fed out of phase (where the beginning of the RF period applied to the feed point of the vertical element is not in time phase with that applied to the horizontal), the resultant

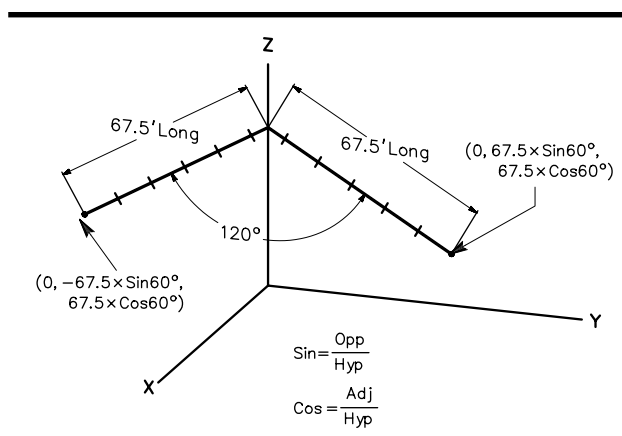


**Fig D—Model for a 135-foot long horizontal dipole, 50 feet above the ground. The dipole is over the y-axis. The wire has been segmented into 11 segments, with the center of segment number 6 as the feed point. Note that the left-hand end of the antenna is  $-67.5$  feet from the center feed point and that the right-hand end is at  $67.5$  feet from the center.**

our dipole has been divided into 11 segments for 80-m operation. The use of 11 segments, an odd rather than an even number such as 10, places the dipole's feedpoint (the "source" in *NEC*-parlance) right at the antenna's center and at the center of segment number six.

Since we intend to use our 135-foot long dipole on all HF amateur bands, the number of segments used actually should vary with frequency. The penalty for using more segments in a program like *NEC* is that the program slows down roughly as the square of the segments—double the number and the speed drops to a fourth. However, using too few segments will introduce inaccuracies, particularly in computing the feed-point impedance. The commercial versions of *NEC* handle such nitty-gritty details automatically.

Let's get a little more complicated and specify the



**Fig E—Model for an inverted-V dipole, with an included angle between the two legs of  $120^\circ$ . Sine and cosine functions are used to describe the heights of the end points for the sloping arms of the antenna.**

135-foot dipole, configured as an inverted-V. Here, as shown in [Fig D](#), you must specify *two* wires. The two wires join at the top,  $(0, 0, 50)$  feet. Now the specification of the source becomes more complicated. The easiest way is to specify two sources, one on each end segment at the junction of the two wires. If you are using the "native" version of *NEC*, you may have to go back to your high-school trigonometry book to figure out how to specify the end points of our "droopy" dipole, with its  $120^\circ$  included angle. [Fig D](#) shows the details, along with the trig equations needed.

So, you see that antenna modeling isn't entirely a cut-and-dried procedure. The commercial programs do their best to hide some of the more unwieldy parts of *NEC*, but there's still some art mixed in with the science. And as always, there are trade-offs to be made—segments versus speed, for example.

polarization is *elliptical*. Circular polarization is a special case of elliptical polarization. The wave front of a circularly polarized signal appears (in passing a fixed observer) to rotate every 90° between vertical and horizontal, making a complete 360° rotation once every period. Field intensities are *equal* at all instantaneous polarizations. Circular polarization is frequently used for space communications, and is discussed further in [Chapter 19](#).

Sky-wave transmission usually changes the polarization of traveling waves. (This is discussed in [Chapter 23](#).) The

polarization of receiving and transmitting antennas in the 3 to 30-MHz range, where almost all communication is by means of sky wave, need not be the same at both ends of a communication circuit (except for distances of a few miles). In this range the choice of polarization for the antenna is usually determined by factors such as the height of available antenna supports, polarization of man-made RF noise from nearby sources, probable energy losses in nearby objects, the likelihood of interfering with neighborhood broadcast or TV reception, and general convenience.

## Other Antenna Characteristics

Besides the three main characteristics of impedance, pattern (gain) and polarization, there are some other useful properties of antennas.

### RECIPROcity IN RECEIVING AND TRANSMITTING

Many of the properties of a resonant antenna used for reception are the same as its properties in transmission. It has the same directive pattern in both cases, and delivers maximum signal to the receiver when the signal comes from a direction in which the antenna has its best response. The impedance of the antenna is the same, at the same point of measurement, in receiving as in transmitting.

In the receiving case, the antenna is the source of power delivered to the receiver, rather than the load for a source of power (as in transmitting). Maximum possible output from the receiving antenna is obtained when the load to which the antenna is connected is the same as the impedance of the antenna. We say that the antenna is “matched” to its load.

The power gain in receiving is the same as the gain in transmitting, when certain conditions are met. One such condition is that both antennas (usually  $\lambda/2$ -long antennas) must work into load impedances matched to their own impedances, so that maximum power is transferred in both cases. In addition, the comparison antenna should be oriented so it gives maximum response to the signal used in the test; that is, it should have the same polarization as the incoming signal and should be placed so its direction of maximum gain is toward the signal source.

In long-distance transmission and reception via the ionosphere, the relationship between receiving and transmitting, however, may not be exactly reciprocal. This is because the waves do not always follow exactly the same paths at all times and so may show considerable variation in the time between alternations between transmitting and receiving. Also, when more than one ionospheric layer is involved in the wave travel (see [Chapter 23](#)), it is sometimes possible for reception to be good in one direction and poor in the other, over the same path.

Wave polarization usually shifts in the ionosphere. The tendency is for the arriving wave to be elliptically polarized, regardless of the polarization of the transmitting antenna.

Vertically polarized antennas can be expected to show no more difference between transmission and reception than horizontally polarized antennas. On the average, however, an antenna that transmits well in a certain direction also gives favorable reception from the same direction, despite ionospheric variations.

### Frequency Scaling

Any antenna design can be scaled in size for use on another frequency or on another amateur band. The dimensions of the antenna may be scaled with Eq 8 below.

$$D = \frac{f_1}{f_2} \times d \quad (\text{Eq 8})$$

where

D = scaled dimension

d = original design dimension

f<sub>1</sub> = original design frequency

f<sub>2</sub> = scaled frequency (frequency of intended operation)

From this equation, a published antenna design for, say, 14 MHz, can be scaled in size and constructed for operation on 18 MHz, or any other desired band. Similarly, an antenna design could be developed experimentally at VHF or UHF and then scaled for operation in one of the HF bands. For example, from Eq 8, an element of 39.0 inches length at 144 MHz would be scaled to 14 MHz as follows:  $D = 144/14 \times 39 = 401.1$  inches, or 33.43 feet.

To scale an antenna properly, *all* physical dimensions must be scaled, including element lengths, element spacings, boom diameters, and element diameters. Lengths and spacings may be scaled in a straightforward manner as in the above example, but element diameters are often not as conveniently scaled. For example, assume a 14-MHz antenna is modeled at 144 MHz and perfected with  $3/8$ -inch cylindrical elements. For proper scaling to 14 MHz, the elements should be cylindrical, of  $144/14 \times 3/8$  or 3.86 inches diameter. From a realistic standpoint, a 4-inch diameter might be acceptable, but cylindrical elements of 4-inch diameter in lengths of 33 feet or so would be quite unwieldy (and quite expensive; not to mention heavy). Choosing another, more suitable diameter is the only practical answer.

## DIAMETER SCALING

Simply changing the diameter of dipole type elements during the scaling process is not satisfactory without making a corresponding element-length correction. This is because changing the diameter results in a change in the  $\lambda/\text{dia}$  ratio from the original design, and this alters the corresponding resonant frequency of the element. The element length must be corrected to compensate for the effect of the different diameter actually used.

To be more precise, however, the purpose of diameter scaling is not to maintain the same resonant frequency for the element, but to maintain the same ratio of self-resistance to self-reactance at the operating frequency—that is, the  $Q$  of the scaled element should be the same as that of the original element. This is not always possible to achieve exactly for elements that use several telescoping sections of tubing.

## TAPERED ELEMENTS

Rotatable beam antennas are usually constructed with elements made of metal tubing. The general practice at HF is to taper the elements with lengths of telescoping tubing. The center section has a large diameter, but the ends are relatively small. This reduces not only the weight, but also the cost of materials for the elements. Tapering of HF Yagi elements is discussed in detail in [Chapter 11](#).

## Length Correction for Tapered Elements

The effect of tapering an element is to alter its electrical length. That is to say, two elements of the same length, one cylindrical and one tapered but with the same average diameter as the cylindrical element, will not be resonant at the same frequency. The tapered element must be made longer than the cylindrical element for the same resonant frequency.

A procedure for calculating the length for tapered elements has been worked out by Dave Leeson, W6NL (ex-W6QHS), from work done by Schelkunoff at Bell Labs and is presented in Leeson's book, *Physical Design of Yagi Antennas*. In the software accompanying this book is a subroutine called EFFLEN.FOR. It is written in Fortran and is used in the *SCALE* program to compute the "effective length" of a tapered element. The algorithm uses the W6NL-Schelkunoff algorithm and is commented step-by-step to show what is happening. Calculations are made for only one half of an element, assuming the element is symmetrical about the point of boom attachment.

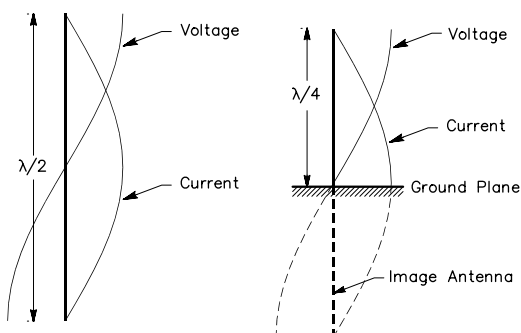
Also, read the documentation SCALE.TXT for the *SCALE* program, which will automatically do the complex mathematics to scale a Yagi design from one frequency to another, or from one taper schedule to another.

# The Vertical Monopole

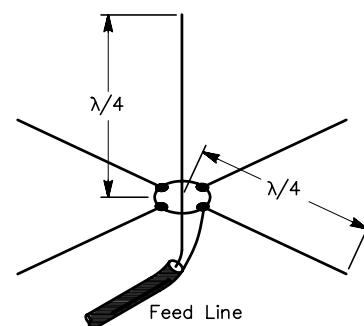
So far in this discussion on Antenna Fundamentals, we have been using the free-space, center-fed dipole as our main example. Another simple form of antenna derived from a dipole is called a *monopole*. The name suggests that this is one half of a dipole, and so it is. The monopole is always used in conjunction with a *ground plane*, which acts as a sort of electrical mirror. See **Fig 21**, where a  $\lambda/2$  dipole and a  $\lambda/4$  monopole are compared. The *image antenna* for the monopole is the dotted line beneath the ground plane. The

image forms the "missing second half" of the antenna, transforming a monopole into the functional equivalent of a dipole. From this explanation you can see where the term *image plane* is sometimes used instead of ground plane.

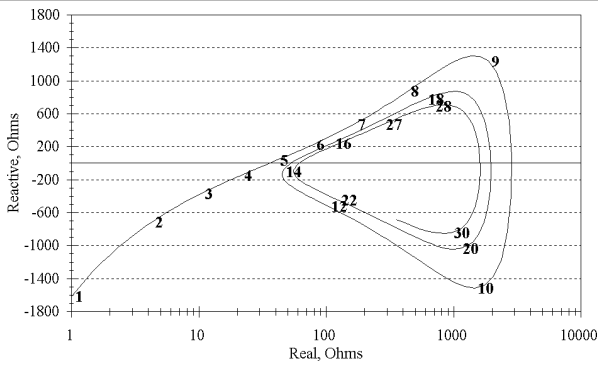
Although we have been focusing throughout this chapter on antennas in free space, practical monopoles are usually mounted vertically with respect to the surface of the ground. As such, they are called *vertical monopoles*, or simply *verticals*. A practical vertical is supplied power by



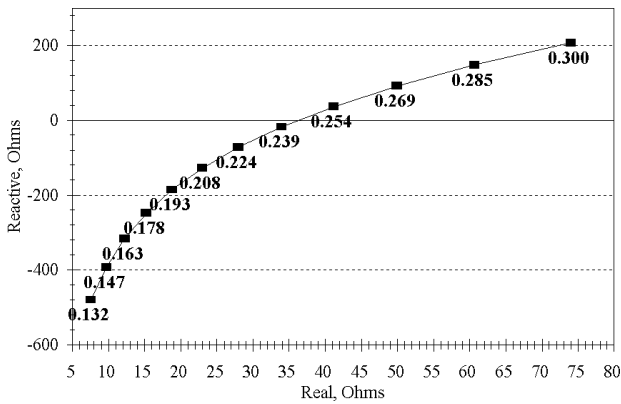
**Fig 21**—The  $\lambda/2$  antenna and its  $\lambda/4$  counterpart. The missing quarter wavelength can be considered to be supplied as an image in the ground, if it is of good conductivity.



**Fig 22**—The ground-plane antenna. Power is applied between the base of the vertical radiator and the center of the four ground plane wires.



**Fig 23—Feed-point impedance versus frequency for a theoretical 50-foot high grounded vertical monopole made of #14 wire. The numbers along the curve show the frequency in MHz. This was computed using “perfect” ground. Real ground losses will add to the feed-point impedance shown in an actual antenna system.**



**Fig 24—Feed-point impedance for the same antennas as in Fig 21, but calibrated in wavelength rather than frequency, over the range from 0.132λ to 0.300λ, above and below the quarter-wave resonance.**

feeding the radiator against a ground system, usually made up of a series of paralleled wires radiating from and laid out in a circular pattern around the base of the antenna. These wires are termed *radials*.

The term “ground plane” is also used to describe a vertical antenna employing a  $\lambda/4$ -long vertical radiator working against a *counterpoise* system, another name for the ground plane that supplies the missing half of the antenna. The counterpoise for a ground-plane antenna consists of four  $\lambda/4$ -long radials elevated well above the earth. See Fig 22.

Chapter 3 devotes much attention to the requirements for an efficient grounding system for vertical monopole antennas, and Chapter 6 gives more information on ground-plane verticals.

## Characteristics of a $\lambda/4$ Monopole

The free-space directional characteristics of a  $\lambda/4$  monopole with its ground plane are the same as that of a  $\lambda/2$  antenna in free space. A  $\lambda/4$  monopole has an *omnidirectional* radiation pattern in the plane perpendicular to the monopole.

The current in a  $\lambda/4$  monopole varies practically sinusoidally (as is the case with a  $\lambda/2$  wire), and is highest at the ground-plane connection. The RF voltage, however, is highest at the open (top) end and minimum at the ground plane. The feed-point resistance close to  $\lambda/4$  resonance of a vertical monopole over a “perfect ground plane” is one-half that for a  $\lambda/2$  dipole at its  $\lambda/2$  resonance. In this case, a perfect ground plane is an infinitely large, lossless conductor.

See Fig 23, which shows the feed-point impedance of a vertical antenna made of #14 wire, 50 feet long, located over perfect ground. This is over the whole HF range from 1 to 30 MHz. Again, there is nothing special about the choice of 50 feet for the length of the vertical radiator; it is simply a convenient length for evaluation. Fig 24 shows an expanded portion of the frequency range above and below the  $\lambda/4$  resonant point, but now calibrated in terms of wavelength. Note that this particular antenna goes through  $\lambda/4$  resonance at a length of  $0.244\lambda$ , not at exactly  $0.25\lambda$ . The exact length for resonance varies with the diameter of the wire used, just as it does for the  $\lambda/2$  dipole at its  $\lambda/2$  resonance.

The word “height” is usually used for a vertical monopole antenna whose base is on or near the ground, and in this context, height has the same meaning as “length” when applied to  $\lambda/2$  dipole antennas. Older texts often refer to heights in electrical degrees, referenced to a free-space wavelength of  $360^\circ$ , but here height is expressed in terms of the free-space wavelength. The range shown in Fig 23 is from  $0.132\lambda$  to  $0.300\lambda$ , corresponding to a frequency range of 2.0 to 5.9 MHz.

The reactive portion of the feed-point impedance depends highly on the length/dia ratio of the conductor, as was discussed previously for a horizontal center-fed dipole. The impedance curve in Figs 23 and 24 is based on a #14 conductor having a length/dia ratio of about 800 to 1. As usual, thicker antennas can be expected to show less reactance at a given height, and thinner antennas will show more.

## Efficiency of Vertical Monopoles

This topic of the efficiency of vertical monopole systems will be covered in detail in Chapter 3, but it’s worth noting at this point that the efficiency of a real vertical antenna over real earth often suffers dramatically compared with that of a  $\lambda/2$  antenna. Without a fairly elaborate grounding system, the efficiency is not likely to exceed 50%, and it may be much less, particularly at monopole heights below  $\lambda/4$ .

## BIBLIOGRAPHY

J. S. Belrose, “Short Antennas for Mobile Operation,” *QST*, Sep 1953.

- G. H. Brown, "The Phase and Magnitude of Earth Currents Near Radio Transmitting Antennas," *Proc IRE*, Feb 1935.
- G. H. Brown, R. F. Lewis and J. Epstein, "Ground Systems as a Factor in Antenna Efficiency," *Proc IRE*, Jun 1937, pp 753-787.
- G. H. Brown and O. M. Woodward, Jr., "Experimentally Determined Impedance Characteristics of Cylindrical Antennas," *Proc IRE*, April 1945.
- A. Christman, "Elevated Vertical Antenna Systems," *QST*, Aug 1988, pp 35-42.
- R. B. Dome, "Increased Radiating Efficiency for Short Antennas," *QST*, Sep 1934, pp 9-12.
- A. C. Doty, Jr., J. A. Frey and H. J. Mills, "Characteristics of the Counterpoise and Elevated Ground Screen," Professional Program, Session 9, Southcon '83 (IEEE), Atlanta, GA, Jan 1983.
- A. C. Doty, Jr., J. A. Frey and H. J. Mills, "Efficient Ground Systems for Vertical Antennas," *QST*, Feb 1983, pp 20-25.
- A. C. Doty, Jr., technical paper presentation, "Capacitive Bottom Loading and Other Aspects of Vertical Antennas," Technical Symposium, Radio Club of America, New York City, Nov 20, 1987.
- A. C. Doty, Jr., J. A. Frey and H. J. Mills, "Vertical Antennas: New Design and Construction Data," *The ARRL Antenna Compendium, Volume 2* (Newington: ARRL, 1989), pp 2-9.
- R. Fosberg, "Some Notes on Ground Systems for 160 Meters," *QST*, Apr 1965, pp 65-67.
- G. Grammer, "More on the Directivity of Horizontal Antennas; Harmonic Operation—Effects of Tilting," *QST*, Mar 1937, pp 38-40, 92, 94, 98.
- H. E. Green, "Design Data for Short and Medium Length Yagi-Uda Arrays," *Trans IE Australia*, Vol EE-2, No. 1, Mar 1966.
- H. J. Mills, technical paper presentation, "Impedance Transformation Provided by Folded Monopole Antennas," Technical Symposium, Radio Club of America, New York City, Nov 20, 1987.
- B. Myers, "The W2PV Four-Element Yagi," *QST*, Oct 1986, pp 15-19.
- L. Richard, "Parallel Dipoles of 300-Ohm Ribbon," *QST*, Mar 1957.
- J. H. Richmond, "Monopole Antenna on Circular Disc," *IEEE Trans on Antennas and Propagation*, Vol. AP-32, No. 12, Dec 1984.
- W. Schulz, "Designing a Vertical Antenna," *QST*, Sep 1978, pp 19-21.
- J. Sevick, "The Ground-Image Vertical Antenna," *QST*, Jul 1971, pp 16-17, 22.
- J. Sevick, "The W2FMI 20-Meter Vertical Beam," *QST*, Jun 1972, pp 14-18.
- J. Sevick, "The W2FMI Ground-Mounted Short Vertical," *QST*, Mar 1973, pp. 13-18, 41.
- J. Sevick, "A High Performance 20-, 40- and 80-Meter Vertical System," *QST*, Dec 1973.
- J. Sevick, "Short Ground-Radial Systems for Short Verticals," *QST*, Apr 1978, pp 30-33.
- C. E. Smith and E. M. Johnson, "Performance of Short Antennas," *Proc IRE*, Oct 1947.
- J. Stanley, "Optimum Ground Systems for Vertical Antennas," *QST*, Dec 1976, pp 13-15.
- R. E. Stephens, "Admittance Matching the Ground-Plane Antenna to Coaxial Transmission Line," Technical Correspondence, *QST*, Apr 1973, pp 55-57.
- D. Sumner, "Cushcraft 32-19 'Boomer' and 324-QK Stacking Kit," Product Review, *QST*, Nov 1980, pp 48-49.
- W. van B. Roberts, "Input Impedance of a Folded Dipole," *RCA Review*, Jun 1947.
- E. M. Williams, "Radiating Characteristics of Short-Wave Loop Aerials," *Proc IRE*, Oct 1940.

### TEXTBOOKS ON ANTENNAS

- C. A. Balanis, *Antenna Theory, Analysis and Design* (New York: Harper & Row, 1982).
- D. S. Bond, *Radio Direction Finders*, 1st ed. (New York: McGraw-Hill Book Co).
- W. N. Caron, *Antenna Impedance Matching* (Newington: ARRL, 1989).
- K. Davies, *Ionospheric Radio Propagation*—National Bureau of Standards Monograph 80 (Washington, DC: U.S. Government Printing Office, April 1, 1965).
- R. S. Elliott, *Antenna Theory and Design* (Englewood Cliffs, NJ: Prentice Hall, 1981).
- A. E. Harper, *Rhombic Antenna Design* (New York: D. Van Nostrand Co, Inc, 1941).
- K. Henney, *Principles of Radio* (New York: John Wiley and Sons, 1938), p 462.
- H. Jasik, *Antenna Engineering Handbook*, 1st ed. (New York: McGraw-Hill, 1961).
- W. C. Johnson, *Transmission Lines and Networks*, 1st ed. (New York: McGraw-Hill Book Co, 1950).
- R. C. Johnson and H. Jasik, *Antenna Engineering Handbook*, 2nd ed. (New York: McGraw-Hill, 1984).
- E. C. Jordan and K. G. Balmain, *Electromagnetic Waves and Radiating Systems*, 2nd ed. (Englewood Cliffs, NJ: Prentice-Hall, Inc, 1968).
- R. Keen, *Wireless Direction Finding*, 3rd ed. (London: Wireless World).
- R. W. P. King, *Theory of Linear Antennas* (Cambridge, MA: Harvard Univ. Press, 1956).
- R. W. P. King, H. R. Mimno and A. H. Wing, *Transmission Lines, Antennas and Waveguides* (New York: Dover Publications, Inc, 1965).
- King, Mack and Sandler, *Arrays of Cylindrical Dipoles* (London: Cambridge Univ Press, 1968).
- M. G. Knitter, Ed., *Loop Antennas—Design and Theory* (Cambridge, WI: National Radio Club, 1983).
- M. G. Knitter, Ed., *Beverage and Long Wire Antennas—Design and Theory* (Cambridge, WI: National Radio Club, 1983).

- J. D. Kraus, *Electromagnetics* (New York: McGraw-Hill Book Co).
- J. D. Kraus, *Antennas*, 2nd ed. (New York: McGraw-Hill Book Co, 1988).
- E. A. Laport, *Radio Antenna Engineering* (New York: McGraw-Hill Book Co, 1952).
- J. L. Lawson, *Yagi-Antenna Design*, 1st ed. (Newington: ARRL, 1986).
- P. H. Lee, *The Amateur Radio Vertical Antenna Handbook*, 2nd ed. (Port Washington, NY: Cowen Publishing Co., 1984).
- A. W. Lowe, *Reflector Antennas* (New York: IEEE Press, 1978).
- M. W. Maxwell, *Reflections—Transmission Lines and Antennas* (Newington: ARRL, 1990). Out of print.
- G. M. Miller, *Modern Electronic Communication* (Englewood Cliffs, NJ: Prentice Hall, 1983).
- V. A. Misek, *The Beverage Antenna Handbook* (Hudson, NH: V. A. Misek, 1977).
- T. Moreno, *Microwave Transmission Design Data* (New York: McGraw-Hill, 1948).
- L. A. Moxon, *HF Antennas for All Locations* (Potters Bar, Herts: Radio Society of Great Britain, 1982), pp 109-111.
- Ramo and Whinnery, *Fields and Waves in Modern Radio* (New York: John Wiley & Sons).
- V. H. Rumsey, *Frequency Independent Antennas* (New York: Academic Press, 1966).
- P. N. Saveskie, *Radio Propagation Handbook* (Blue Ridge Summit, PA: Tab Books, Inc, 1980).
- S. A. Schelkunoff, *Advanced Antenna Theory* (New York: John Wiley & Sons, Inc, 1952).
- S. A. Schelkunoff and H. T. Friis, *Antennas Theory and Practice* (New York: John Wiley & Sons, Inc, 1952).
- J. Sevick, *Transmission Line Transformers* (Atlanta: Noble Publishing, 1996).
- H. H. Skilling, *Electric Transmission Lines* (New York: McGraw-Hill Book Co, Inc, 1951).
- M. Slurzburg and W. Osterheld, *Electrical Essentials of Radio* (New York: McGraw-Hill Book Co, Inc, 1944).
- G. Southworth, *Principles and Applications of Waveguide Transmission* (New York: D. Van Nostrand Co, 1950).
- F. E. Terman, *Radio Engineers' Handbook*, 1st ed. (New York, London: McGraw-Hill Book Co, 1943).
- F. E. Terman, *Radio Engineering*, 3rd ed. (New York: McGraw-Hill, 1947).
- S. Uda and Y. Mushiake, *Yagi-Uda Antenna* (Sendai, Japan: Sasaki Publishing Co, 1954). [Published in English—Ed.]
- P. P. Viezbicke, "Yagi Antenna Design," NBS Technical Note 688 (U. S. Dept of Commerce/National Bureau of Standards, Boulder, CO), Dec 1976.
- G. B. Welch, *Wave Propagation and Antennas* (New York: D. Van Nostrand Co, 1958), pp 180-182.
- The GIANT Book of Amateur Radio Antennas* (Blue Ridge Summit, PA: Tab Books, 1979), pp 55-85.
- IEEE Standard Dictionary of Electrical and Electronics Terms*, 3rd ed. (New York: IEEE, 1984).
- Radio Broadcast Ground Systems*, available from Smith Electronics, Inc, 8200 Snowville Rd, Cleveland, OH 44141.
- Radio Communication Handbook*, 5th ed. (London: RSGB, 1976).
- Radio Direction Finding*, published by the Happy Flyers, 1811 Hillman Ave, Belmont, CA 94002

# The Effects of Ground

The ground around and under an antenna is part of the environment in which any actual antenna must operate. Chapter 2 dealt mainly with theoretical antennas in free space, completely removed from the influence of the ground. This chapter is devoted to exploring the interactions between antennas and the ground.

The interactions can be analyzed depending on where they occur relative to two areas surrounding the antenna: the *reactive near field* and the *radiating far field*. You will recall that the reactive near field only exists very close to the antenna itself. In this region the antenna acts as though it were a large lumped-constant inductor or capacitor, where energy is stored but very little is actually radiated. The interaction with the ground in this area creates mutual

impedances between the antenna and its environment and these interactions not only modify the feed-point impedance of an antenna, but often increase losses.

In the radiating far field, the presence of ground profoundly influences the radiation pattern of a real antenna. The interaction is different, depending on the antenna's polarization with respect to the ground. For horizontally polarized antennas, the *shape* of the radiated pattern in the elevation plane depends primarily on the antenna's height above ground. For vertically polarized antennas, both the *shape* and the *strength* of the radiated pattern in the elevation plane strongly depend on the nature of the ground itself (its dielectric constant and conductivity at RF), as well as on the height of the antenna above ground.

## The Effects of Ground in the Reactive Near Field

### FEED-POINT IMPEDANCE VERSUS HEIGHT ABOVE GROUND

Waves radiated from the antenna directly downward reflect vertically from the ground and, in passing the antenna on their upward journey, induce a voltage in it. The magnitude and phase of the current resulting from this induced voltage depends on the height of the antenna above the reflecting surface.

The total current in the antenna consists of two components. The amplitude of the first is determined by the power supplied by the transmitter and the free-space feed-point resistance of the antenna. The second component is induced in the antenna by the wave reflected from the ground. This second component of current, while considerably smaller than the first at most useful antenna heights, is by no means insignificant. At some heights, the two components will be in phase, so the total current is larger than is indicated by the free-space feed-point resistance. At other heights, the two components are out of phase, and the total current is the difference between the two components.

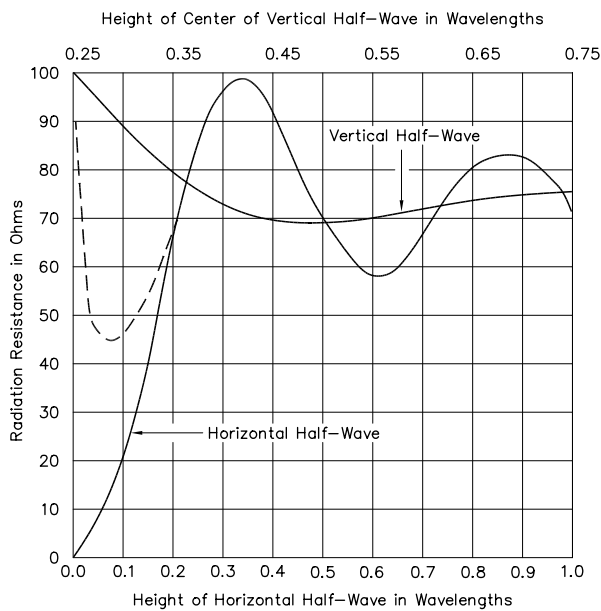
Changing the height of the antenna above ground will change the amount of current flow, assuming that the power input to the antenna is constant. A higher current at the same power input means that the effective resistance of the antenna is lower, and vice versa. In other words, the feed-point

resistance of the antenna is affected by the height of the antenna above ground because of mutual coupling between the antenna and the ground beneath it.

The electrical characteristics of the ground affect both the amplitude and the phase of reflected signals. For this reason, the electrical characteristics of the ground under the antenna will have some effect on the impedance of that antenna, the reflected wave having been influenced by the ground. Different impedance values may be encountered when an antenna is erected at identical heights but over different types of earth.

Fig 1 shows the way in which the radiation resistance of horizontal and vertical half-wave antennas vary with height above ground (in  $\lambda$ , wavelengths). For horizontally polarized half-wave antennas, the differences between the effects of perfect ground and real earth are negligible if the antenna height is greater than  $0.2\lambda$ . At lower heights, the feed-point resistance over perfect ground decreases rapidly as the antenna is brought closer to a theoretically perfect ground, but this does not occur so rapidly for actual ground. Over real earth, the resistance begins increasing at heights below about  $0.08\lambda$ . The reason for the increasing resistance at very low heights is that more and more of the reactive (induction) field of the antenna is absorbed by the lossy ground in close proximity.

For a vertically polarized  $\lambda/2$ -long dipole, differences



**Fig 1—Variation in radiation resistance of vertical and horizontal half-wave antennas at various heights above flat ground. Solid lines are for perfectly conducting ground; the broken line is the radiation resistance of horizontal half-wave antennas at low heights over real ground.**

between the effects of perfect ground and real earth on the feed-point impedance is negligible, as seen in Fig 1. The theoretical half-wave antennas on which this chart is based are assumed to have infinitely thin conductors.

### GROUND SYSTEMS FOR VERTICAL MONOPOLES

In this section, we’ll look at vertical monopoles, which require some sort of ground system in order to make up for the “missing” second half of the antenna. In [Chapter 2](#) and up to this point in this chapter, the discussion about vertical monopoles has mainly been for antennas where “perfect ground” is available. We have also briefly looked at the ground-plane vertical in free space, where the four ground-plane radials form a built-in “ground” system.

Perfect ground makes a vertical monopole into the functional equivalent of a center-fed dipole, although the feed-point resistance at resonance is half that of the center-fed dipole. But how can we manage to create that elusive “perfect ground” for our real vertical antennas?

#### Simulating a Perfect Ground in the Reactive Near Field

The effect of a perfectly conducting ground (as far as feed-point resistance and losses are concerned) can be simulated under a real antenna by installing a very large metal screen or mesh, such as poultry netting (chicken wire) or hardware cloth, on or near the surface of the ground. The screen (also called a counterpoise system, especially if it is

elevated off the ground) should extend at least a half wavelength in every direction from the antenna. The feed-point resistance of a quarter-wave long, thin vertical radiator over such a ground screen will approach the theoretical value of 36  $\Omega$ .

Based on the results of a study published in 1937 by Brown, Lewis and Epstein (see [Bibliography](#)), a grounding system consisting of 120 wires, each at least  $\lambda/2$  long, extending radially from the base of the antenna and spaced equally around a circle, is also the practical equivalent of perfectly conducting ground for reactive field currents. The wires can either be laid directly on the surface of the ground or buried a few inches below.

Another approach to simulating a perfect ground system is to utilize the ground-plane antenna, with its four ground-plane radials elevated well above lossy earth. Heights greater than  $\lambda/8$  have proven to yield excellent results. See [Chapter 6](#) for more details on practical ground-plane verticals.

For a vertical antenna, a large ground screen, either made of wire mesh or a multitude of radials, or an elevated system of ground-plane radials will reduce ground losses near the antenna. This is because the screen conductors are solidly bonded to each other and the resistance is much lower than that of the lossy, low-conductivity earth itself. If the ground screen or elevated ground plane were not present, RF currents would be forced to flow through the lossy, low-conductivity earth to return to the base of the radiator. The ground screen or elevated ground plane in effect shield ground-return currents from the lossy earth.

### Less-Than-Ideal Ground Systems

Now, what happens when something less than an ideal ground screen is used as the ground plane for a vertical monopole? You will recall from [Chapter 2](#) that an ideal ground-plane antenna in free space requires only four radials as a ground counterpoise. Thus, the four-radial ground plane antenna in free space represents one limit in the range of possibilities for a ground system, while a perfect ground screen represents the other limit. Real antenna systems over real ground represent intermediate points in this continuum of ground configurations.

A great deal of mystery and lack of information seems to surround the vertical antenna ground system. In the case of ground-mounted vertical antennas, many general statements such as “the more radials the better” and “lots of short radials are better than a few long ones” have served as rules of thumb to some, but many questions as to relative performance differences and optimum number for a given length remain unanswered. Most of these questions boil down to one: namely, how many radials, and how long, should be used in a vertical antenna installation?

A ground system with 120  $\lambda/2$  radials is not very practical for many amateur installations, which often must contend with limited space for putting together such an ideal system. Unfortunately, ground-return loss resistance increases rapidly when the number of radials is reduced. At



**Table 1**  
**Optimum Ground-System Configurations**

	Configuration Designation					
	A	B	C	D	E	F
Number of radials	16	24	36	60	90	120
Length of each radial in wavelengths	0.1	0.125	0.15	0.2	0.25	0.4
Spacing of radials in degrees	22.5	15	10	6	4	3
Total length of radial wire installed, in wavelengths	1.6	3	5.4	12	22.5	48
Power loss in dB at low angles with a quarter-wave radiating element	3	2	1.5	1	0.5	0*
Feed-point impedance in ohms with a quarter-wave radiating element	52	46	43	40	37	35

Note: Configuration designations are indicated only for text reference.

\*Reference. The loss of this configuration is negligible compared to a perfectly conducting ground.

least 15 radials should be used if at all possible. Experimental measurements show that with this number, the loss resistance is such as to decrease the antenna efficiency to about 50% if the monopole vertical length is  $\lambda/4$ .

As the number of radials is reduced, the vertical radiator length required for optimum results with a particular number of radials also decreases—in other words, if only a small number of radials can be used with a shortened vertical radiator, there is no point in extending them out  $\lambda/2$ . This comes about because the reactive near field of a short vertical radiator extends out radially less than that for a full-sized  $\lambda/4$  vertical. With 15 radials, for example, a radiator length of  $\lambda/8$  is sufficient. With as few as two radials the length is almost unimportant, but the efficiency of a  $\lambda/4$  antenna with such a grounding system is only about 25%. (It is considerably lower with shorter antennas.)

In general, a large number of radials (even though some or all of them must be short) is preferable to a few long radials for a vertical antenna mounted on the ground. The conductor size is relatively unimportant; #12 to #28 copper wire is suitable. The measurement of the actual ground-loss resistance at the operating frequency is difficult. The power loss in the ground depends on the current concentration near the base of the antenna, and this depends on the antenna height. Typical values for small radial systems (15 or less) have been measured to be from about 5 to 30  $\Omega$ , for antenna heights from  $\lambda/16$  to  $\lambda/4$ . The impedance seen at the feed point of the antenna is the sum of the loss and the radiation resistance.

**Table 1** summarizes these conclusions. [John Stanley, K4ERO](#), first presented this material in December 1976 *QST*. One source of information on ground-system design is *Radio Broadcast Ground Systems* (see the Bibliography at the end of this chapter). Most of the data presented in Table 1 is taken from that source, or derived from the interpolation of data contained therein.

Table 1 gives numbers of radials and a corresponding

optimum radial length for each case. Using radials considerably longer than suggested for a given number or using a lot more radials than suggested for a given length, while not adverse to performance, does not yield significant improvement either. That would represent a nonoptimum use of wire and construction time. Each suggested configuration represents an optimum relationship between length and number for a fixed amount of total. The loss figures in Table 1 are calculated for a quarter-wave radiating element. A very rough approximation of loss when using shorter antennas can be obtained by doubling the loss in dB each time the antenna height is halved. For longer antennas the losses decrease, approaching 2 dB for configuration A of Table 1 for a half-wave radiator. Longer antennas yield correspondingly better performance.

The table is based on average ground conductivity. Variation of the loss values shown can be considerable, especially for configurations using fewer radials. Those building antennas over dry, sandy or rocky ground should expect more loss. On the other hand, higher than average soil conductivity and wet soils would make the “compromise” configurations (those with the fewest radials) even more attractive.

When antennas are combined into arrays, either of parasitic or all-driven types, mutual impedances lower the radiation resistance of the elements, drastically increasing the effects of ground loss. For instance, an antenna with a 52- $\Omega$  feed-point impedance and 10  $\Omega$  of ground-loss resistance will have an efficiency of approximately 83%. An array of two similar antennas in a driven array with the same ground loss may have an efficiency of 70% or less. Special precautions must be taken in such cases to achieve satisfactory operation. Generally speaking, a wide-spaced broadside array presents little problem, but a close-spaced end-fire array should be avoided for transmission, unless the lower loss configurations are used or other precautions taken. [Chapter 8](#) covers the subject of vertical arrays in great detail.

In cases where directivity is desirable or real estate limitations dictates, longer, more closely spaced radials can be installed in one direction, and shorter, more widely spaced in another. Multiband ground systems can be designed using different optimum configurations for different bands. Usually it is most convenient to start at the lowest frequency with fewer radials and add more short radials for better performance on the higher bands.

There is nothing sacred about the exact details of the configurations given, and slight changes in the number of radials and lengths will not cause serious problems. Thus, a configuration with 32 or 40 radials of  $0.14 \lambda$  or  $0.16 \lambda$  will work as well as configuration C shown in the table.

If less than 90 radials are contemplated, there is no need to make them a quarter wavelength long. This differs rather dramatically from the case of a ground plane antenna, where four  $\lambda/4$  resonant radials are installed above ground. For the ground-mounted antenna, four  $\lambda/4$  radials are far from optimum. Because the radials of a ground-mounted vertical are actually on, if not slightly below the surface, they are coupled by capacitance or conduction to the ground, and thus resonance effects are not important. The basic function of radials is to provide a low-loss return path for ground currents. The reason that short radials are sufficient

when few are used is that at the perimeter of the circle to which the ground system extends, the few wires are so spread apart that most of the return currents are already in the ground between the wires rather than in the wires themselves. As more wires are added, the spaces between them are reduced and longer length helps to provide a path for currents still farther out.

*Radio Broadcast Ground Systems* states, “Experiments show that the ground system consisting of only 15 radial wires need not be more than 0.1 wavelength long, while the system consisting of 113 radials is still effective out to 0.5 wavelength.” Many graphs in that publication confirm this statement. This is not to say that these two systems will perform equally well; they most certainly will not. However, if  $0.1 \lambda$  is as long as the radials can be, there is little point in using more than 15 of them.

The antenna designer should (1) study the cost of various radial configurations versus the gain of each; (2) compare alternative means of improving transmitted signal and their cost (more power, etc); (3) consider increasing the physical antenna height (the electrical length) of the vertical radiator, instead of improving the ground system; and (4) use multielement arrays for directivity and gain, observing the necessary precautions related to mutual impedances discussed in [Chapter 8](#).

## The Effect of Ground in the Far Field

The properties of the ground in the far field of an antenna are very important, especially for a vertically polarized antenna. Even if the ground system for a vertical has been optimized to reduce ground-return losses in the reactive near field to an insignificant level, the electrical properties of the ground may still diminish far-field performance to lower levels than “perfect-ground” analyses might lead you to expect. The key is that ground reflections from horizontally and vertically polarized waves behave very differently.

### Reflections in General

Over flat ground, both horizontally or vertically polarized downgoing waves launched from an antenna into the far field strike the surface and are reflected by a process very similar to that by which light waves are reflected from a mirror. As is the case with light waves, the angle of reflection is the same as the angle of incidence, so a wave striking the surface at an angle of, say,  $15^\circ$  is reflected upward from the surface at  $15^\circ$ .

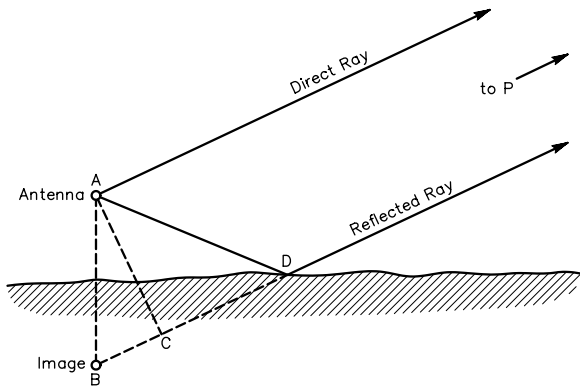
The reflected waves combine with direct waves (those radiated at angles above the horizon) in various ways. Some of the factors that influence this combining process are the height of the antenna, its length, the electrical characteristics of the ground, and as mentioned above, the polarization of the wave. At some elevation angles above the horizon the direct and reflected waves are exactly in phase—that is, the maximum field strengths of both waves are reached at the

same time at the same point in space, and the directions of the fields are the same. In such a case, the resultant field strength for that angle is simply the sum of the direct and reflected fields. (This represents a theoretical increase in field strength of 6 dB over the free-space pattern at these angles.)

At other elevation angles the two waves are completely out of phase—that is, the fields’ intensities are equal at the same instant and the directions are opposite. At still other angles, the resultant field will have intermediate values. Thus, the effect of the ground is to increase radiation intensity at some elevation angles and to decrease it at others. When you plot the results as an elevation pattern, you will see *lobes* and *nulls*, as described in [Chapter 2](#).

The concept of an image antenna is often useful to show the effect of reflection. As [Fig 2](#) shows, the reflected ray has the same path length (AD equals BD) that it would if it originated at a virtual second antenna with the same characteristics as the real antenna, but situated below the ground just as far as the actual antenna is above it.

Now, if we look at the antenna and its image over perfect ground from a remote point on the surface of the ground, we will see that the currents in a horizontally polarized antenna and its image are flowing in opposite directions, or in other words, are  $180^\circ$  out of phase. But the currents in a vertically polarized antenna and its image are flowing in the *same* direction—they are *in* phase. This  $180^\circ$  phase difference between the vertically and horizontally



**Fig 2**—At any distant point, P, the field strength will be the vector sum of the direct ray and the reflected ray. The reflected ray travels farther than the direct ray by the distance BC, where the reflected ray is considered to originate at the “image” antenna.

polarized reflections off ground is what makes the combinations with direct waves behave so very differently.

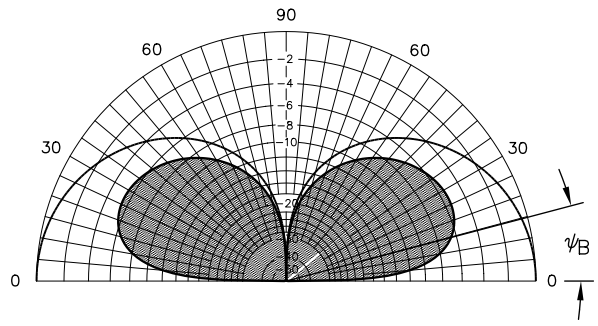
### FAR-FIELD GROUND REFLECTIONS AND THE VERTICAL ANTENNA

A vertical’s azimuthal directivity is omnidirectional. A  $\lambda/2$  vertical over ideal earth has the elevation-plane radiation pattern shown by the solid line in **Fig 3**. Over real earth, however, the pattern looks more like the shaded one in the same diagram. In this case, the low-angle radiation that might be hoped for because of the perfect-ground performance is not realized.

Now look at **Fig 4A**, which compares the computed elevation-angle response for two half-wave dipoles at 14 MHz. One is oriented horizontally over ground at a height of  $\lambda/2$  and the other is oriented vertically, with its center just over  $\lambda/4$  high (so that the bottom end of the wire doesn’t actually touch the ground). The ground is “average” in dielectric constant and conductivity. At a  $15^\circ$  elevation angle, the horizontally polarized dipole has almost 7 dB more gain than its vertical brother. Contrast **Fig 4A** to the comparison in **Fig 4B**, where the peak gain of a vertically polarized half-wave dipole over seawater, which is virtually perfect for RF reflections, is quite comparable with the horizontal dipole’s response at  $15^\circ$ , and exceeds the horizontally polarized antenna dramatically below  $15^\circ$  elevation.

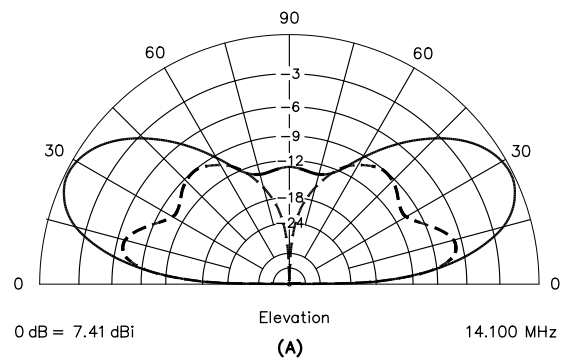
To understand why the desired low-angle radiation is not delivered over real earth, examine **Fig 5A**. Radiation from each antenna segment reaches a point P in space by two paths; one directly from the antenna, path AP, and the other by reflection from the earth, path AGP. (Note that P is so far away that the slight difference in angles is insignificant—for practical purposes the waves are parallel to each other at point P.)

If the earth were a perfectly conducting surface, there would be no phase shift of the vertically polarized wave upon reflection at point G. The two waves would add together

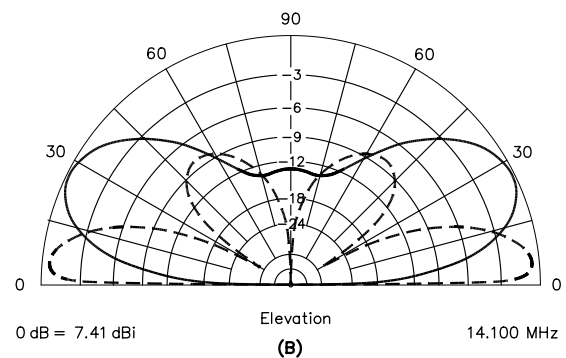


**Fig 3**—Vertical-plane radiation pattern for a ground-mounted quarter-wave vertical. The solid line is the pattern for perfect earth. The shaded pattern shows how the response is modified over average earth ( $k = 13$ ,  $G = 0.005 \text{ S/m}$ ) at 14 MHz.  $\psi$  is the pseudo-Brewster angle (PBA), in this case  $14.8^\circ$ .

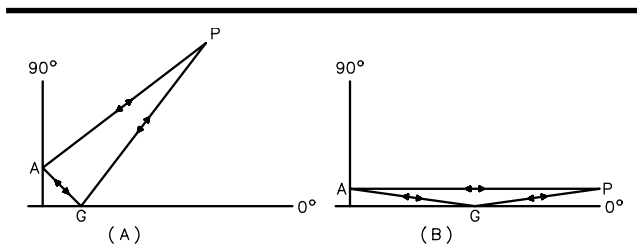
---  $\lambda/2$  Vertical Dipole, Center at  $\lambda/2$  Over Average Ground  
 —  $\lambda/2$  Horizontal Dipole,  $\lambda/2$  Over Average Ground



---  $\lambda/2$  Vertical Dipole, Center at  $\lambda/2$  Over Seawater  
 —  $\lambda/2$  Horizontal at  $\lambda/2$  Over Average Ground



**Fig 4**—At A, comparison of horizontal and vertical  $\lambda/2$  dipoles over average ground. Average ground has conductivity of 5 mS/m and dielectric constant of 13. Center of each antenna is  $\lambda/2$  over ground. Horizontal antenna is much less affected by far-field ground losses compared with its vertical counterpart. At B, comparison of 20-meter  $\lambda/4$  vertical dipole raised  $\lambda/2$  over seawater with  $\lambda/2$  horizontal dipole,  $\lambda/2$  over average ground. Seawater is great for verticals!



**Fig 5—The direct wave and the reflected wave combine at point P to form the pattern (P is very far from the antenna). At A the two paths AP and AGP differ appreciably in length, while at B these two path lengths are nearly equal.**

with some phase difference because of the different path lengths. This difference in path lengths of the two waves is why the free-space radiation pattern differs from the pattern of the same antenna over ground. Now consider a point P that is close to the horizon, as in Fig 5B. The path lengths AP and AGP are almost the same, so the magnitudes of the two waves add together, producing a maximum at zero angle of radiation. The arrows on the waves point both ways since the process works similarly for transmitting and receiving.

With real earth, however, the reflected wave undergoes a change in both *amplitude* and *phase* in the reflection process. Indeed, at a low enough elevation angle, the phase of the reflected wave will actually change by 180° and its magnitude will then subtract from that of the direct wave. At a zero takeoff angle, it will be almost equal in amplitude, but 180° out of phase with the direct wave. Complete cancellation will result in a null, inhibiting any radiation or reception at 0°.

### THE PSEUDO-BREWSTER ANGLE AND THE VERTICAL ANTENNA

Much of the material presented here regarding pseudo-

Brewster angle was prepared by Charles J. Michaels, W7XC, and first appeared in July 1987 *QST*, with additional information in *The ARRL Antenna Compendium, Vol 3*. (See the [Bibliography](#) at the end of this chapter.)

Most fishermen have noticed that when the sun is low, its light is reflected from the water’s surface as glare, obscuring the underwater view. When the sun is high, however, the sunlight penetrates the water and it is possible to see objects below the surface of the water. The angle at which this transition takes place is known as the *Brewster angle*, named for the Scottish physicist, Sir David Brewster (1781-1868).

A similar situation exists in the case of vertically polarized antennas; the RF energy behaves as the sunlight in the optical system, and the earth under the antenna acts as the water. The *pseudo-Brewster angle* (PBA) is the angle at which the reflected wave is 90° out of phase with respect to the direct wave. “Pseudo” is used here because the RF effect is similar to the optical effect from which the term gets its name. Below this angle, the reflected wave is between 90° and 180° out of phase with the direct wave, so some degree of cancellation takes place. The largest amount of cancellation occurs near 0°, and steadily less cancellation occurs as the PBA is approached from below.

The factors that determine the PBA for a particular location *are not related to the antenna itself, but to the ground around it*. The first of these factors is earth conductivity, G, which is a measure of the ability of the soil to conduct electricity. Conductivity is the inverse of resistance. The second factor is the dielectric constant, k, which is a unitless quantity that corresponds to the capacitive effect of the earth. For both of these quantities, the higher the number, the better the ground (for vertical antenna purposes). The third factor determining the PBA for a given location is the frequency of operation. The PBA increases with increasing frequency,

**Table 2  
Conductivities and Dielectric Constants for Common Types of Earth**

Surface Type	Dielectric Constant	Conductivity (S/m)	Relative Quality
Fresh water	80	0.001	
Salt water	81	5.0	
Pastoral, low hills, rich soil, typ Dallas, TX, to Lincoln, NE areas	20	0.0303	Very good
Pastoral, low hills, rich soil, typ OH and IL	14	0.01	
Flat country, marshy, densely wooded, typ LA near Mississippi River	12	0.0075	
Pastoral, medium hills and forestation, typ MD, PA, NY (exclusive of mountains and coastline)	13	0.006	
Pastoral, medium hills and forestation, heavy clay soil, typ central VA	13	0.005	Average
Rocky soil, steep hills, typ mountainous	12-14	0.002	Poor
Sandy, dry, flat, coastal	10	0.002	
Cities, industrial areas	5	0.001	Very Poor
Cities, heavy industrial areas, high buildings	3	0.001	Extremely poor

all other conditions being equal. **Table 2** gives typical values of conductivity and dielectric constant for different types of soil. The map of **Fig 6** shows the approximate conductivity values for different areas in the continental United States.

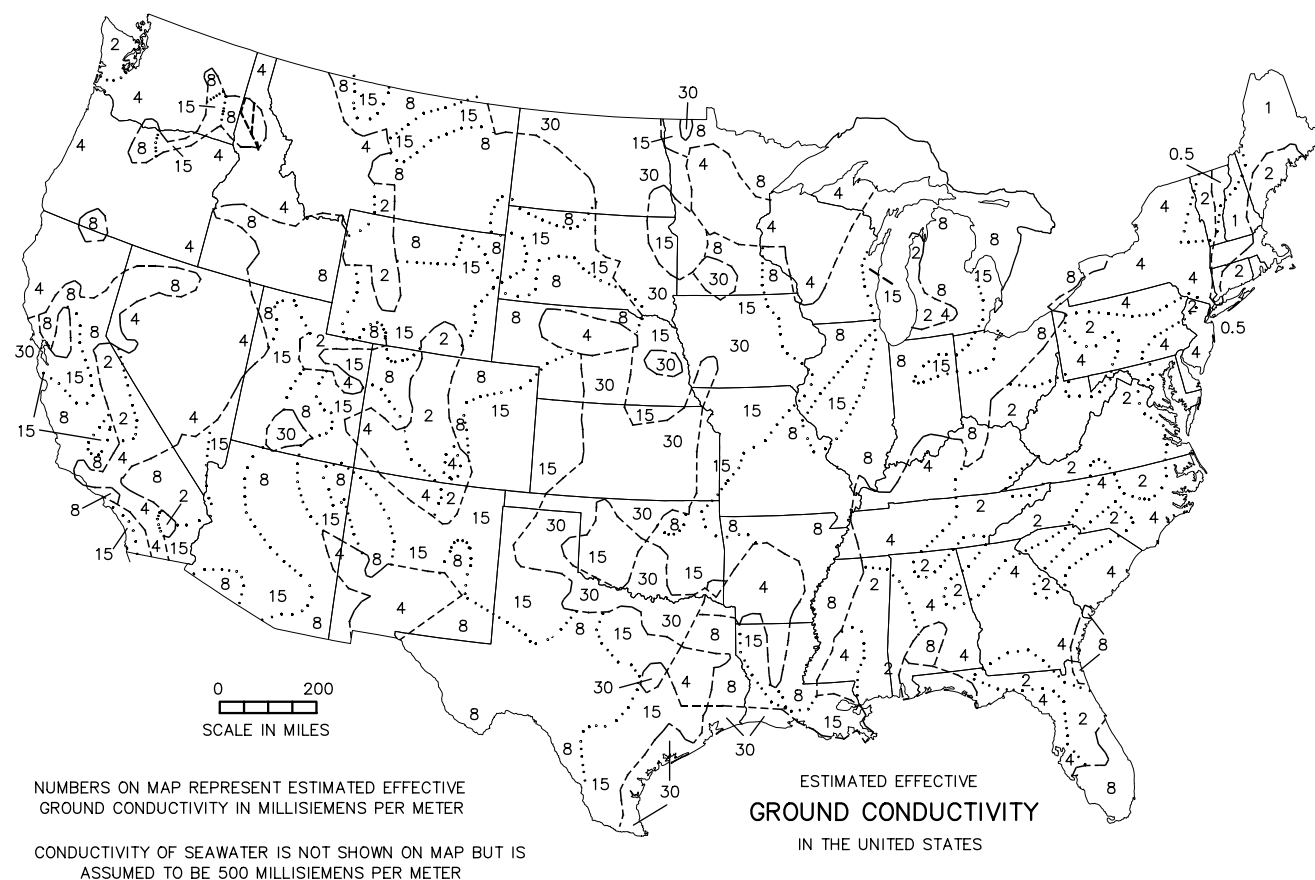
As the frequency is increased, the role of the dielectric constant in determining the PBA becomes more significant. **Table 3** shows how the PBA varies with changes in ground conductivity, dielectric constant and frequency. The table shows trends in PBA dependency on ground constants and frequency. The constants chosen are not necessarily typical of any geographical area; they are just examples.

At angles below the PBA, the reflected vertically polarized wave subtracts from the direct wave, causing the radiation intensity to fall off rapidly. Similarly, above the PBA, the reflected wave adds to the direct wave, and the radiated pattern approaches the perfect-earth pattern. **Fig 3** shows the PBA, usually labeled  $\psi_B$ .

When plotting vertical-antenna radiation patterns over real earth, the reflected wave from an antenna segment is multiplied by a factor called the *vertical reflection coefficient*, and the product is then added vectorially to the direct wave to get the resultant. The reflection coefficient consists of an

**Table 3**  
**Pseudo-Brewster Angle Variation with Frequency, Dielectric Constant, and Conductivity**

Frequency (MHz)	Dielectric Constant	Conductivity (S/m)	PBA (degrees)
7	20	0.0303	6.4
	13	0.005	13.3
	13	0.002	15.0
	5	0.001	23.2
	3	0.001	27.8
14	20	0.0303	8.6
	13	0.005	14.8
	13	0.002	15.4
	5	0.001	23.8
	3	0.001	29.5
21	20	0.0303	10.0
	13	0.005	15.2
	13	0.002	15.4
	5	0.001	24.0
	3	0.001	29.8



**Fig 6—Typical average soil conductivities for the continental United States. Numeric values indicate conductivities in millisiemens per meter (mS/m), where 1.0 mS/m = 0.001 S/m.**

attenuation factor,  $A$ , and a phase angle,  $\phi$ , and is usually expressed as  $A\angle\phi$ . ( $\phi$  is always a negative angle, because the earth acts as a lossy capacitor in this situation.) The following equation can be used to calculate the reflection coefficient for vertically polarized waves, for earth of given conductivity and dielectric constant at any frequency and elevation angle (also called the wave angle in many texts).

$$A_{\text{vert}} \angle \phi = \frac{k' \sin \Psi - \sqrt{k' - \cos^2 \Psi}}{k' \sin \Psi + \sqrt{k' - \cos^2 \Psi}} \quad (\text{Eq 1})$$

where

$A_{\text{vert}} \angle \phi$  = vertical reflection coefficient  
 $\Psi$  = elevation angle

$$k' = k - j \left( \frac{1.8 \times 10^4 \times G}{f} \right)$$

$k$  = dielectric constant of earth ( $k$  for air = 1)

$G$  = conductivity of earth in S/m

$f$  = frequency in MHz

$j$  = complex operator ( $\sqrt{-1}$ )

Solving this equation for several points indicates what effect the earth has on vertically polarized signals at a particular location for a given frequency range. **Fig 7** shows the reflection coefficient as a function of elevation angle at 21 MHz over average earth ( $G = 0.005$  S/m,  $k = 13$ ). Note that as the phase curve,  $\phi$ , passes through  $90^\circ$ , the attenuation curve,  $A$ , passes through a minimum at the same wave angle,  $\Psi$ . This is the PBA. At this angle, the reflected wave is not only at a phase angle of  $90^\circ$  with respect to the direct wave, but is so low in amplitude that it does not aid the direct wave by a significant amount. In the case illustrated in Fig 7 this elevation angle is about  $15^\circ$ .

### Variations in PBA with Earth Quality

From Eq 1, it is quite a task to search for either the  $90^\circ$  phase point or the attenuation curve minimum for a wide variety of earth conditions. Instead, the PBA can be calculated directly from the following equation.

$$\Psi_B = \sqrt{\frac{k - 1 + \sqrt{(x^2 + k^2)^2 (k - 1)^2 + x^2 [(x^2 + k^2)^2 - 1]}}{(x^2 + k^2)^2 - 1}} \quad (\text{Eq 2})$$

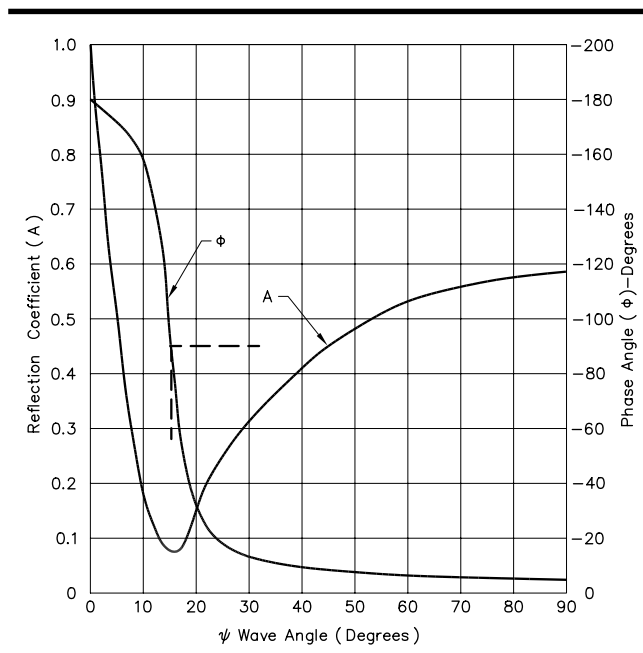
where  $k$ ,  $G$  and  $f$  are as defined for Eq 1.

**Fig 8** shows curves calculated using Eq 2 for several different earth conditions, at frequencies between 1.8 and 30 MHz. As expected, poorer earths yield higher PBAs. Unfortunately, at the higher frequencies (where low-angle radiation is most important for DX work), the PBAs are highest. The PBA is the same for both transmitting and receiving.

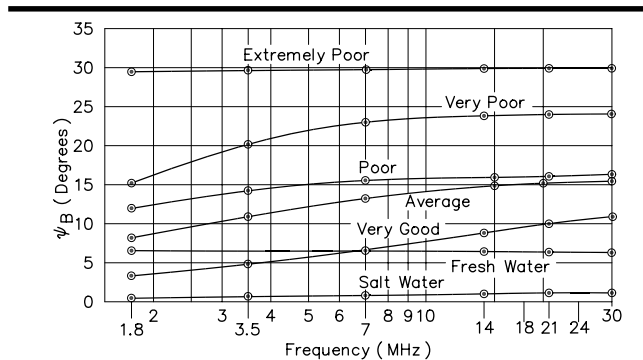
### Relating PBA to Location and Frequency

Table 2 lists the physical descriptions of various kinds of earth with their respective conductivities and dielectric constants, as mentioned earlier. Note that in general, the dielectric constants and conductivities are higher for better earths. This enables the labeling of the earth characteristics as extremely poor, very poor, poor, average, very good, and so on, without the complications that would result from treating the two parameters independently.

Fresh water and salt water are special cases; in spite of high resistivity, the fresh-water PBA is  $6.4^\circ$ , and is nearly independent of frequency below 30 MHz. Salt water, because of its extremely high conductivity, has a PBA that never



**Fig 7**—Reflection coefficient for vertically polarized waves.  $A$  and  $\phi$  are magnitude and angle for wave angles  $\Psi$ . This case is for average earth, ( $k = 13$ ,  $G = 0.005$  S/m), at 21 MHz.



**Fig 8**—Pseudo-Brewster angle ( $\Psi$ ) for various qualities of earth over the 1.8 to 30-MHz frequency range. Note that the frequency scale is logarithmic. The constants used for each curve are given in Table 2.

exceeds 1° in this frequency range. The extremely low conductivity listed for cities (last case) in Table 2 results more from the clutter of surrounding buildings and other obstructions than any actual earth characteristic. The PBA at any location can be found for a given frequency from the curves in Fig 8.

### FLAT-GROUND REFLECTIONS AND HORIZONTALLY POLARIZED WAVES

The situation for horizontal antennas is different from that of verticals. Fig 9 shows the reflection coefficient for horizontally polarized waves over average earth at 21 MHz. Note that in this case, the phase-angle departure from 0° never gets very large, and the attenuation factor that causes the most loss for high-angle signals approaches unity for low angles. Attenuation increases with progressively poorer earth types. In calculating the broadside radiation pattern of a horizontal  $\lambda/2$  dipole, the perfect-earth image current, equal to the true antenna current but 180° out of phase with it) is multiplied by the horizontal reflection coefficient given by Eq 3 below. The product is then added vectorially to the direct wave to get the resultant at that elevation angle. The reflection coefficient for horizontally polarized waves can be calculated using the following equation.

$$A_{\text{Horiz}} \angle \phi = \frac{\sqrt{k' - \cos^2 \psi} - \sin \psi}{\sqrt{k' - \cos^2 \psi} + \sin \psi} \quad (\text{Eq 3})$$

where

$A_{\text{Horiz}} \angle \phi$  = horizontal reflection coefficient  
 $\psi$  = elevation angle

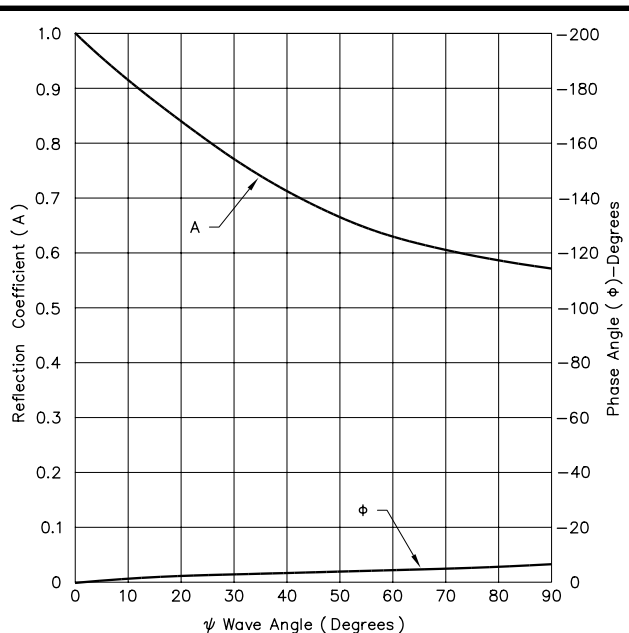


Fig 9—Reflection coefficient for horizontally polarized waves (magnitude A at angle  $\phi$ ), at 21 MHz over average earth ( $k = 13$ ,  $G = 0.005$  S/m).

$$k' = k - j \left( \frac{1.8 \times 10^4 \times G}{f} \right)$$

$k$  = dielectric constant of earth  
 $G$  = conductivity of earth in S/m  
 $f$  = frequency in MHz  
 $j$  = complex operator ( $\sqrt{-1}$ )

For a horizontal antenna near the earth, the resultant pattern is a modification of the free-space pattern of the antenna. Fig 10 shows how this modification takes place for a horizontal  $\lambda/2$  antenna over a perfectly conducting flat surface. The patterns at the left show the relative radiation when one views the antenna from the side; those at the right show the radiation pattern looking at the end of the antenna. Changing the height above ground from  $\lambda/4$  to  $\lambda/2$  makes a significant difference in the high-angle radiation, moving the main lobe down lower.

Note that for an antenna height of  $\lambda/2$  (Fig 10, bottom), the out-of-phase reflection from a perfectly conducting surface creates a null in the pattern at the zenith (90° elevation angle). Over real earth, however, a “filling in” of this null occurs because of ground losses that prevent perfect reflection of high-angle radiation.

At a 0° elevation angle, horizontally polarized antennas also demonstrate a null, because out-of-phase reflection cancels the direct wave. As the elevation angle departs from 0°, however, there is a slight filling-in effect so that over other-than-perfect earth, radiation at lower angles is enhanced compared to a vertical. A horizontal antenna will often outperform a vertical for low-angle DX work, particularly over lossy types of earth at the higher frequencies.

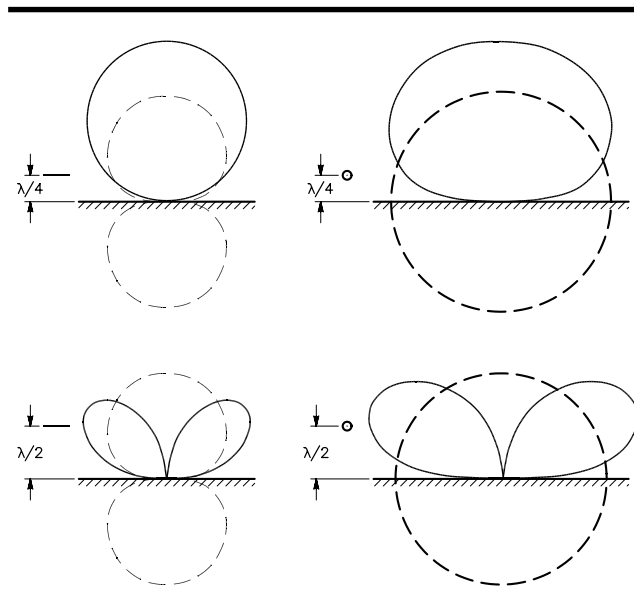


Fig 10—Effect of the ground on the radiation from a horizontal half-wave antenna, for heights of one-fourth and one-half wavelength. Broken lines show what the pattern would be if there were no reflection from the ground (free space).

Reflection coefficients for vertically and horizontally polarized radiation differ considerably at most angles above ground, as can be seen by comparison of Figs 7 and 8. (Both sets of curves were plotted for the same ground constants and at the same frequency, so they may be compared directly.) This is because, as mentioned earlier, the image of a horizontally polarized antenna is out of phase with the antenna itself, and the image of a vertical antenna is in phase with the actual radiator.

The result is that the phase shifts and reflection magnitudes vary greatly at different angles for horizontal and vertical polarization. The magnitude of the reflection coefficient for vertically polarized waves is greatest (near unity) at very low angles, and the phase angle is close to 180°. As mentioned earlier, this cancels nearly all radiation at very low angles. For the same range of angles, the magnitude of the reflection coefficient for horizontally polarized waves is also near unity, but the phase angle is near 0° for the specific conditions shown in Figs 7 and 9. This causes reinforcement of low-angle horizontally polarized waves. At some relatively high angle, the reflection coefficients for horizontally and vertically polarized waves are equal in magnitude and phase. At this angle (approximately 81° for the example case), the effect of ground reflection on vertically and horizontally polarized signals will be exactly the same.

### DEPTH OF RF CURRENT PENETRATION

When considering earth characteristics, questions about depth of RF current penetration often arise. For instance, if a given location consists of a 6-foot layer of soil overlying a highly resistive rock strata, which material dominates? The answer depends on the frequency, the soil and rock dielectric constants, and their respective conductivities. The following equation can be used to calculate the current density at any depth.

$$e^{-pd} = \frac{\text{Current Density at Depth } D}{\text{Current Density at Surface}} \quad (\text{Eq } 4)$$

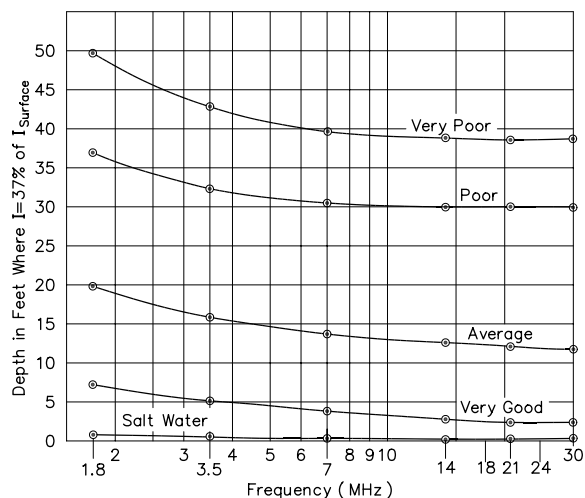
where

- d = depth of penetration in cm
- e = natural logarithm base (2.718)
- X =  $0.008 \times \pi^2 \times f$

$$p = \left( \frac{X \times B}{2} \times \left( \sqrt{1 + \frac{G^2 \times 10^{-4}}{B^2}} - 1 \right) \right)^{1/2}$$

- B =  $5.56 \times 10^{-7} \times k \times f$
- k = dielectric constant of earth
- f = frequency in MHz
- G = conductivity of earth in S/m

After some manipulation of this equation, it can be used to calculate the depth at which the current density is some fraction of that at the surface. The depth at which the current density is 37% ( $1/e$ ) of that at the surface (often referred to as *skin depth*) is the depth at which the current density would



**Fig 11—Depths at which the current density is 37% of that at the surface for different qualities of earth over the 1.8- to 30-MHz frequency range. The depth for fresh water, not plotted, is 156 feet and almost independent of frequency below 30 MHz. See text and Table 2 for ground constants.**

be zero if it were distributed uniformly instead of exponentially. (This  $1/e$  factor appears in many physical situations. For instance, a capacitor charges to within  $1/e$  of full charge within one RC time constant.) At this depth, since the power loss is proportional to the square of the current, approximately 91% of the total power loss has occurred, as has most of the phase shift, and current flow below this level is negligible.

Fig 11 shows the solutions to Eq 4 over the 1.8 to 30-MHz frequency range for various types of earth. For example, in very good earth, substantial RF currents flow down to about 3.3 feet at 14 MHz. This depth goes to 13 feet in average earth and as far as 40 feet in very poor earth. Thus, if the overlying soil is rich, moist loam, the underlying rock strata is of little concern. However, if the soil is only average, the underlying rock may constitute a major consideration in determining the PBA and the depth to which the RF current will penetrate.

The depth in fresh water is about 156 feet and is nearly independent of frequency in the amateur bands below 30 MHz. In salt water, the depth is about seven inches at 1.8 MHz and decreases rather steadily to about two inches at 30 MHz. Dissolved minerals in moist earth increase its conductivity.

The depth-of-penetration curves in Fig 11 illustrate a noteworthy phenomenon. While skin effect confines RF current flow close to the surface of a conductor, the earth is so lossy that RF current penetrates to much greater depths than in most other media. The depth of RF current penetration is a function of frequency as well as earth type. Thus, the only cases in which most of the current flows near the surface are with very highly conductive media (such as salt water), and at frequencies above 30 MHz.



## DIRECTIVE PATTERNS OVER REAL GROUND

As explained in Chapter 2, because antenna radiation patterns are three-dimensional, it is helpful in understanding their operation to use a form of representation showing the vertical directional characteristic for different heights. It is possible to show selected vertical-plane patterns oriented in various directions with respect to the antenna axis. In the case of the horizontal half-wave dipole, a plane running in a direction along the axis and another broadside to the antenna will give a good deal of information.

The effect of reflection from the ground can be expressed as a separate *pattern factor*, given in decibels. For any given elevation angle, adding this factor algebraically to the value for that angle from the free-space pattern for that antenna gives the resultant radiation value at

that angle. The limiting conditions are those represented by the direct ray and the reflected ray being exactly in phase and exactly out of phase, when both, assuming there are no ground losses, have equal amplitudes. Thus, the resultant field strength at a distant point may be either 6 dB greater than the free-space pattern (twice the field strength), or zero, in the limiting cases.

### Horizontally Polarized Antennas

The way in which pattern factors vary with height for horizontal antennas over flat earth is shown graphically in the plots of Fig 12. The solid-line plots are based on perfectly conducting ground, while the shaded plots are based on typical real-earth conditions. These patterns apply to horizontal antennas of any length. While these graphs are,

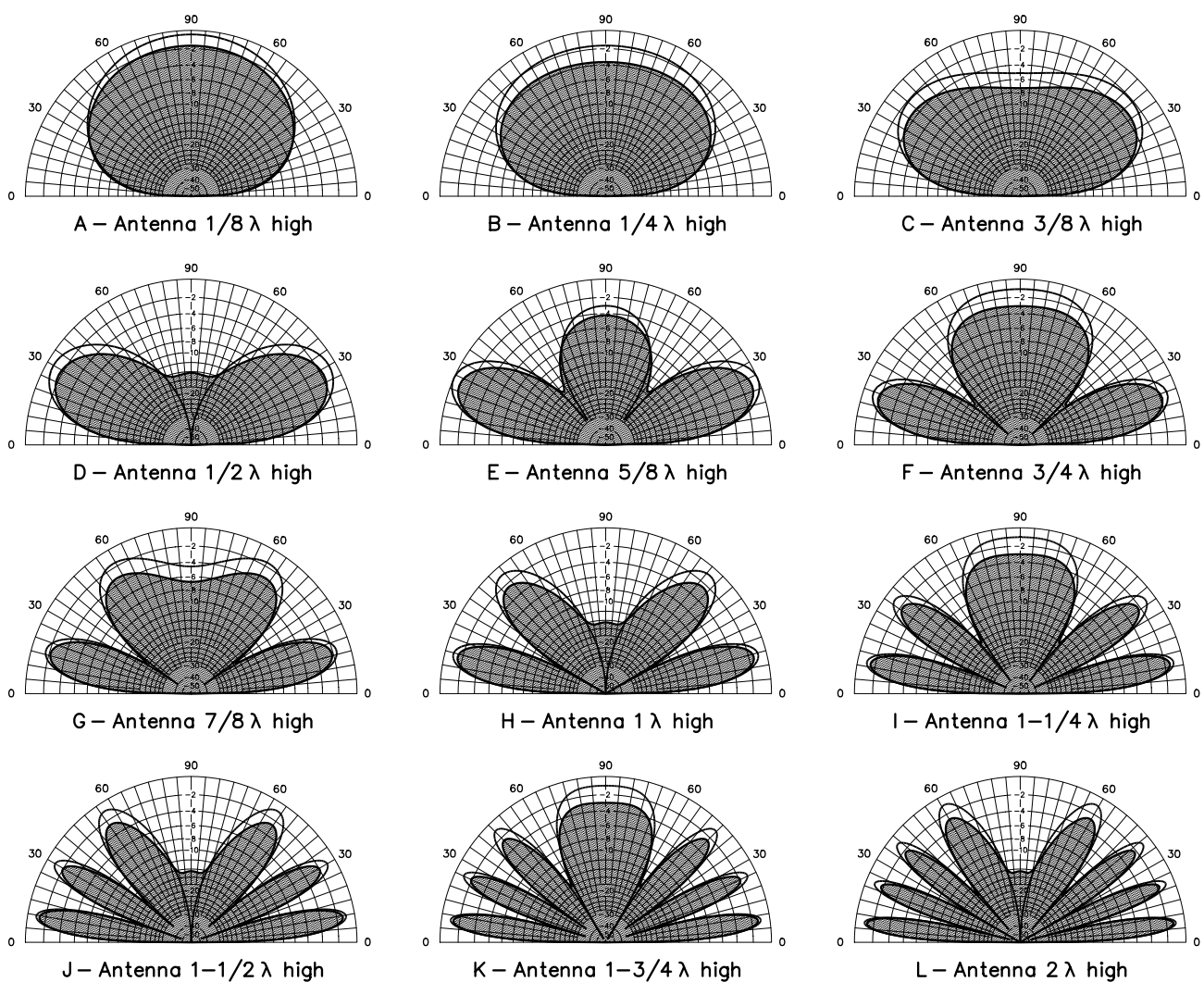


Fig 12—Reflection factors for horizontal antennas at various heights above flat ground. The solid-line curves are the perfect-earth patterns (broadside to the antenna wire); the shaded curves represent the effects of average earth ( $k = 13$ ,  $G = 0.005$  S/m) at 14 MHz. Add 7 dB to values shown for absolute gain in dBd referenced to dipole in free space, or 9.15 dB for gain in dBi. For example, peak gain over perfect earth at  $\frac{3}{8} \lambda$  height is 7 dBd (or 9.15 dBi) at  $25^\circ$  elevation.

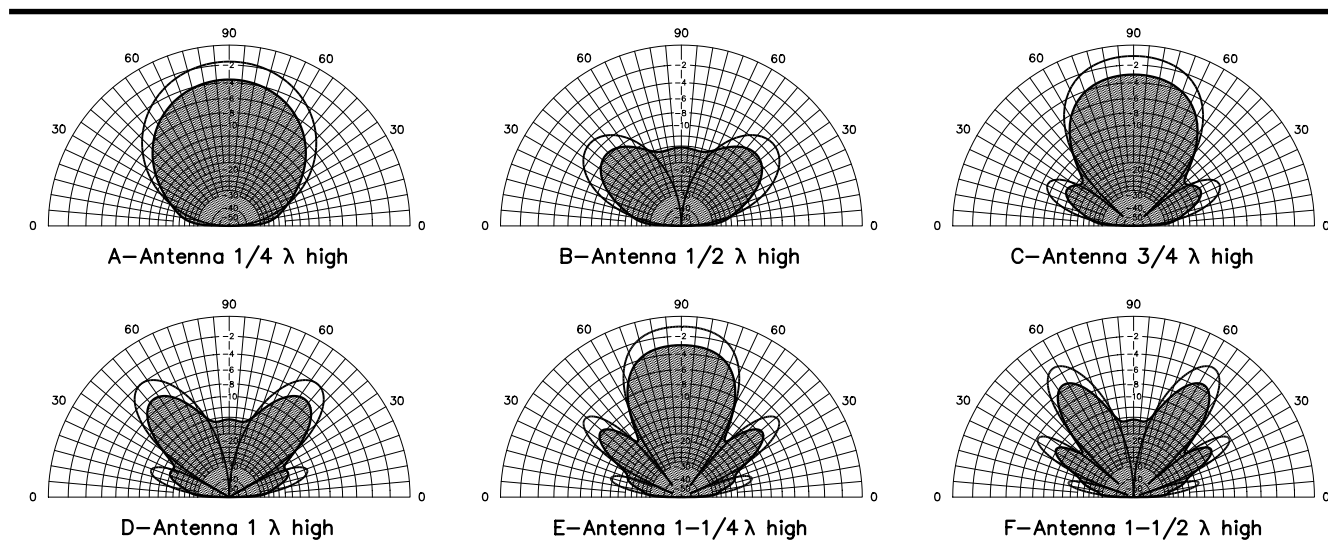
in fact, radiation patterns of horizontal single-wire antennas (dipoles) as viewed from the axis of the wire, it must be remembered that the plots merely represent pattern factors.

Vertical radiation patterns in the directions off the ends of a horizontal half-wave dipole are shown in **Fig 13** for various antenna heights. These patterns are scaled so they may be compared directly to those for the appropriate heights in **Fig 12**. Note that the perfect-earth patterns in Figs 13A and 12B are the same as those in the upper part of **Fig 10**. Note also that the perfect-earth patterns of Figs 13B and 12D are the same as those in the lower section of **Fig 10**. The reduction in field strength off the ends of the wire at the lower angles, as compared with the broadside field strength, is quite apparent. It is also clear from **Fig 13** that, at some heights, the high-angle radiation off the ends is nearly as great as the broadside radiation, making the antenna essentially an omnidirectional radiator.

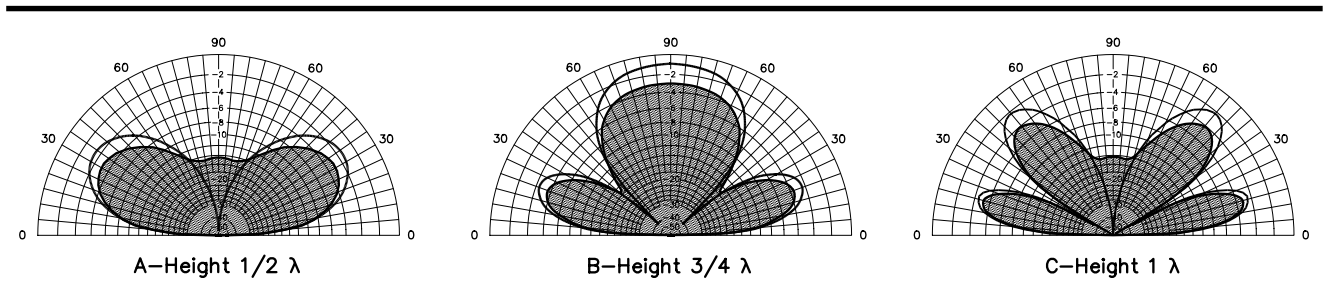
In vertical planes making some intermediate angle between  $0^\circ$  and  $90^\circ$  with the wire axis, the pattern will have

a shape intermediate between the broadside and end-on patterns. By visualizing a smooth transition from the end-on pattern to the broadside pattern as the horizontal angle is varied from  $0^\circ$  to  $90^\circ$ , a fairly good mental picture of the actual solid pattern may be formed. An example is shown in **Fig 14**. At A, the vertical pattern of a half-wave dipole at a height of  $\lambda/2$  is shown through a plane  $45^\circ$  away from the favored direction of the antenna. At B and C, the vertical pattern of the same antenna is shown at heights of  $3\lambda/4$  and  $1\lambda$  (through the same  $45^\circ$  off-axis plane). These patterns are scaled so they may be compared directly with the broadside and end-on patterns for the same antenna (at the appropriate heights) in **Figs 12** and **13**.

The curves presented in **Fig 15** are useful for determining heights of horizontal antennas that give either maximum or minimum reinforcement at any desired wave angle. For instance, if you want to place an antenna at a height so that it will have a null at  $30^\circ$ , the antenna should



**Fig 13**—Vertical-plane radiation patterns of horizontal half-wave antennas off the ends of the antenna wire. The solid-line curves are the flat, perfect-earth patterns, and the shaded curves represent the effects of average flat earth ( $k = 13$ ,  $G = 0.005$  S/m) at 14 MHz. The 0-dB reference in each plot corresponds to the peak of the main lobe in the favored direction of the antenna (the maximum gain). Add 7 dB to values shown for absolute gain in dBd referenced to dipole in free space, or 9.15 dB for gain in dBi.

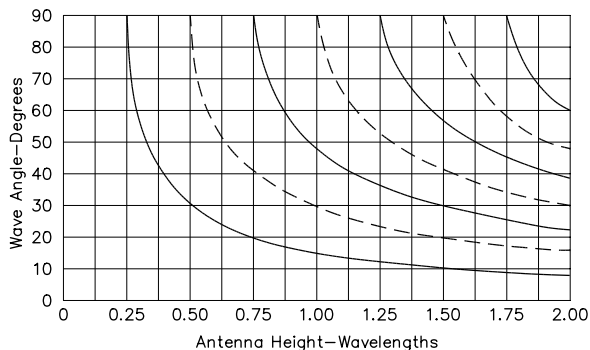


**Fig 14**—Vertical-plane radiation patterns of half-wave horizontal antennas at  $45^\circ$  from the antenna wire over flat ground. The solid-line and shaded curves represent the same conditions as in **Figs 12** and **13**. These patterns are scaled so they may be compared directly with those of **Figs 12** and **13**.

be placed where a broken line crosses the 30° line on the horizontal scale. There are two heights (up to 2 λ) that will yield this null angle: 1 λ and 2 λ.

As a second example, you may want to have the ground reflection give maximum reinforcement of the direct ray from a horizontal antenna at a 20° elevation angle. The antenna height should be 0.75 λ. The same height will give a null at 42° and a second lobe at 90°.

Fig 15 is also useful for visualizing the vertical pattern of a horizontal antenna. For example, if an antenna is erected at



**Fig 15—Angles at which nulls and maxima (factor = 6 dB) in the ground reflection factor appear for antenna heights up to two wavelengths over flat ground. The solid lines are maxima, dashed lines nulls, for all horizontal antennas. See text for examples. Values may also be determined from the trigonometric relationship  $\theta = \arcsin(A/4h)$ , where  $\theta$  is the wave angle and  $h$  is the antenna height in wavelengths. For the first maximum,  $A$  has a value of 1; for the first null  $A$  has a value of 2, for the second maximum 3, for the second null 4, and so on.**

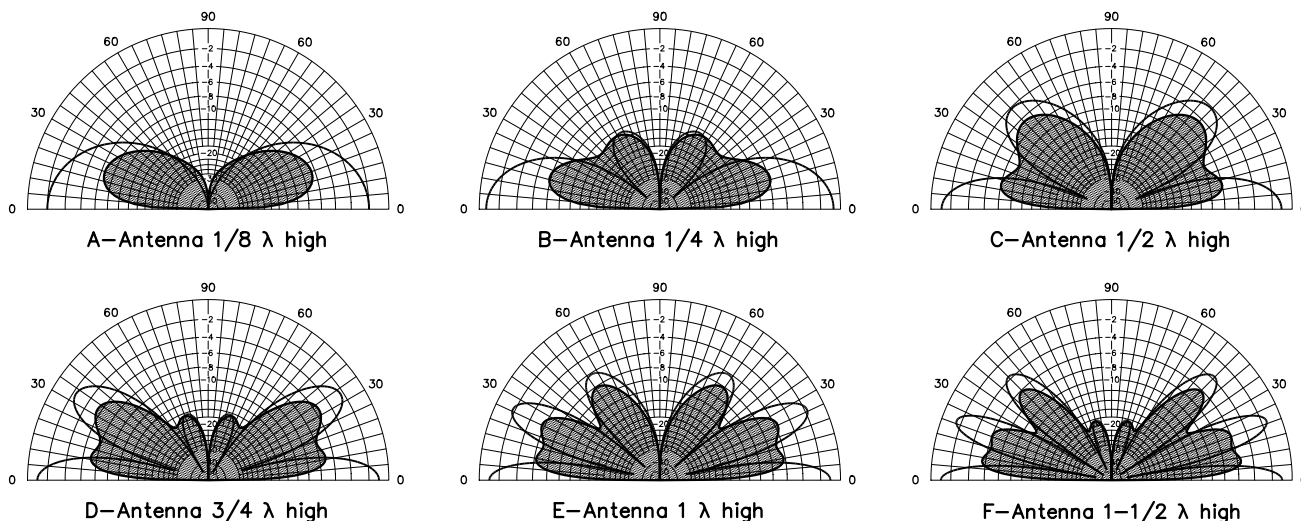
1.25 λ, it will have major lobes (solid-line crossings) at 12° and 37°, as well as at 90° (the zenith). The nulls in this pattern (dashed-line crossings) will appear at 24° and 53°. By using Fig 15 along with wave-angle information contained in Chapter 23, it is possible to calculate the antenna height that will best suit your needs, remembering that this is for flat-earth terrain.

### Vertically Polarized Antennas

In the case of a vertical λ/2 dipole or a ground-plane antenna, the horizontal directional pattern is simply a circle at any elevation angle (although the actual field strength will vary, at the different elevation angles, with the height above ground). Hence, one vertical pattern is sufficient to give complete information (for a given antenna height) about the antenna in any direction with respect to the wire. A series of such patterns for various heights is given in Fig 16. The three-dimensional radiation pattern in each case is formed by rotating the plane pattern about the zenith axis of the graph.

The solid-line curves represent the radiation patterns of the λ/2 vertical dipole at different feed-point heights over perfectly conducting ground. The shaded curves show the patterns produced by the same antennas at the same heights over average ground ( $G = 0.005 \text{ S/m}$ ,  $k = 13$ ) at 14 MHz. The PBA in this case is 14.8°.

In short, far-field losses for vertically polarized antennas are highly dependent on the conductivity and dielectric constant of the earth around the antenna, extending far beyond the ends of any radials used to complete the ground return for the near field. Putting more radials out around the antenna may well decrease ground-return losses in the reactive near field for a vertical monopole, but will not increase radiation at low elevation launch angles in the far field, unless the radials can



**Fig 16—Vertical-plane radiation patterns of a groundplane antenna above flat ground. The height is that of the ground plane, which consists of four radials in a horizontal plane. Solid lines are perfect-earth patterns; shaded curves show the effects of real earth. The patterns are scaled—that is, they may be directly compared to the solid-line ones for comparison of losses at any wave angle. These patterns were calculated for average ground ( $k = 13$ ,  $G = 5 \text{ mS/m}$ ) at 14 MHz. The PBA for these conditions is 14.8°. Add 6 dB to values shown for absolute gain in dB over dipole in free space.**

extend perhaps 100 wavelengths in all directions! Aside from moving to the fabled “salt water swamp on a high hill,” there is very little that someone can do to change the character of the ground that affects the far-field pattern of a real vertical. Classical texts on verticals often show elevation patterns computed over an “infinitely wide, infinitely conducting ground plane.” Real ground, with finite conductivity and less-than-perfect dielectric constant, can severely curtail the low-angle radiation at which verticals are supposed to excel.

While real verticals over real ground are not a sure-fire method to achieve low-angle radiation, cost versus performance and ease of installation are still attributes that can highly recommend verticals to knowledgeable builders. Practical installations for 160 and 80 meters rarely allow amateurs to put up a horizontal antenna high enough to radiate effectively at low elevation angles. After all, a half-wave on 1.8 MHz is 273 feet high, and even at such a lofty height the peak radiation would be at a 30° elevation angle.

## The Effects of Irregular Local Terrain in the Far Field

The following material is condensed and updated from an article by R. Dean Straw, N6BV, in July 1995 *QEX* magazine. The *YT* program, standing for “Yagi Terrain Analysis,” and supporting data files are included on the CD-ROM in the back of this book.

### Choosing a QTH for DXing

The subject of how to choose a QTH for working DX has fascinated hams since the beginning of amateur operations. No doubt, Marconi probably spent a lot of time wandering around Newfoundland looking for a great radio QTH before making the first transatlantic transmission. Putting together a high-performance HF station for contesting or DXing has always followed some pretty simple rules. First, you need the perfect QTH, preferably on a rural mountain top or at least on top of a hill. Even better yet, you need a mountain top surrounded by seawater! Then, after you have found your dream QTH, you put up the biggest antennas you possibly can, on the highest towers you can afford. Then you work all sorts of DX—sunspots willing, of course.

The only trouble with this straightforward formula for success is that it doesn’t always work. Hams fortunate enough to be located on mountain tops with really spectacular drop-offs often find that their highest antennas don’t do very well, especially on 15 or 10 meters, but often even on 20 meters. When they compare their signals with nearby locals in the flatlands, they sometimes (but not always) come out on the losing end, especially when sunspot activity is high.

On the other hand, when the sunspots drop into the cellar, the high antennas on the mountain top are usually the ones crunching the pileups—but again, not always. So, the really ambitious contest aficionados, the guys with lots of resources and infinite enthusiasm, have resorted to putting up antennas at all possible heights, on a multitude of towers.

There is a more scientific way to figure out where and how high to put your antennas to optimize your signal during all parts of the 11-year solar cycle. We advocate a *system approach* to HF station design, in which you need to know the following:

1. The range of elevation angles necessary to get from point A to point B

2. The elevation patterns for various types and configurations of antennas
3. The effect of local terrain on elevation patterns for horizontally polarized antennas.

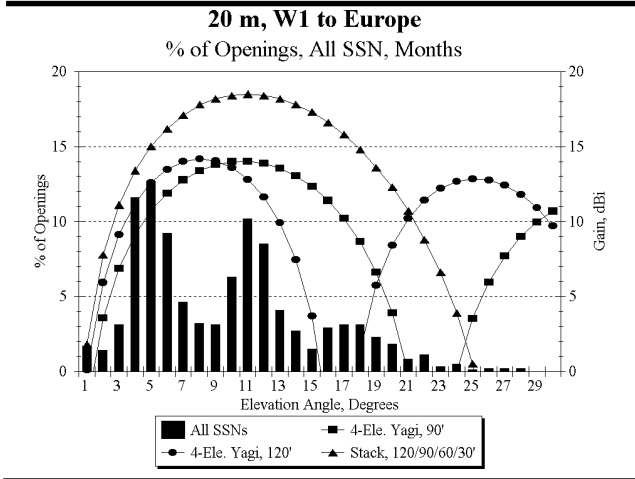
### WHAT IS THE RANGE OF ELEVATION ANGLES NEEDED?

Until 1994, *The ARRL Antenna Book* contained only a limited amount of information about the elevation angles needed for communication throughout the world. In the 1974 edition, Table 1-1 in the Wave Propagation chapter was captioned: “Measured vertical angles of arrival of signals from England at receiving location in New Jersey.”

What the caption didn’t say was that Table 1-1 was derived from measurements made during 1934 by Bell Labs. The highest frequency data seemed pretty shaky, considering that 1934 was the low point of Cycle 17. Neither was this data applicable to any other path, other than the one from New Jersey to England. Nonetheless, many amateurs located throughout the US tried to use the sparse information in Table 1-1 as the only rational data they had for determining how high to mount their antennas. (If they lived on hills, they made estimates on the effect of the terrain, assuming that the hill was adequately represented by a long, unbroken slope. More on this later.)

In 1993 ARRL HQ embarked on a major project to tabulate the range of elevation angles from all regions of the US to important DX QTHs around the world. This was accomplished by running many thousands of computations using the *IONCAP* computer program. *IONCAP* has been under development for more than 25 years by various agencies of the US government and is considered the standard of comparison for propagation programs by many agencies, including the Voice of America, Radio Free Europe, and more than 100 foreign governments throughout the world. *IONCAP* is a real pain in the neck to use, but it is the standard of comparison.

The calculations were done for all levels of solar activity, for all months of the year, and for all 24 hours of the day. The results were gathered into some very large databases, from which special custom-written software extracted detailed statistics. The results appeared in summary



**Fig 17—Graph showing 20-meter percentage of all openings from New England to Europe versus elevation angles, together with overlay of elevation patterns over flat ground for three 20-meter antenna systems. The statistically most likely angle at which the band will be open is 5°, although at any particular hour, day, month and year, the actual angle may well be different.**

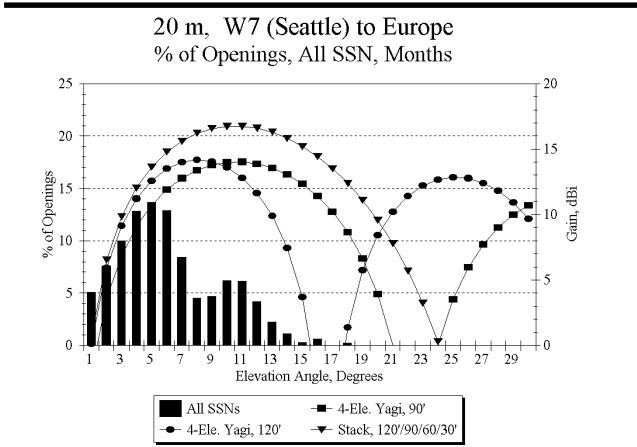
form in Tables 4 through 13 printed in the chapter “Radio Wave Propagation,” Chapter 23, of the 17th Edition and in more detail on the diskette included with that book. (This book, the 19th Edition, contains even more *statistical data*, for more areas of the world, on the accompanying CD-ROM.)

Fig 17 reproduces Fig 28 from Chapter 23. This depicts the full range of elevation angles for the 20-meter path from Newington, Connecticut, to all of Europe. This is for all openings, in all months, over the entire 11-year solar cycle. The most likely elevation angle occurs between 4° to 6° for about 34% of the times when the band is open. There is a secondary peak between 10° to 12°, occurring for about 25% of the time the band is open.

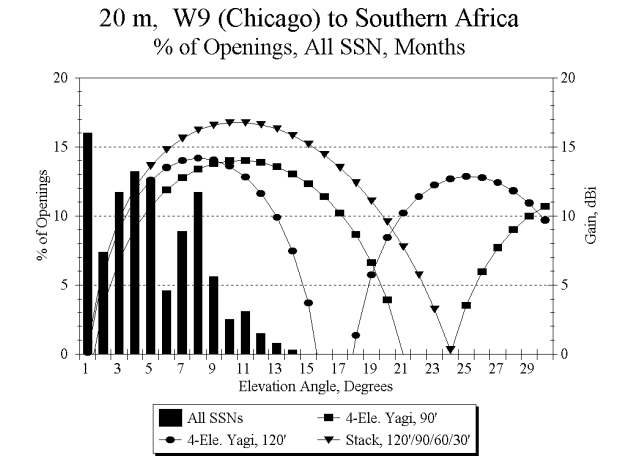
In Fig 17, the statistical angle information is also overlaid with the elevation responses for three different antenna configurations, all mounted over flat ground. The stack of four 4-element Yagis at 120, 90, 60 and 30 feet best covers the whole range of necessary elevation angles among the three systems shown, with the best single antenna arguably being the 90-foot high Yagi.

Now, we must emphasize that these are *statistical entities*— in other words, just because 5° is the “statistically most likely angle” for the 20-meter path from New England to Europe doesn’t mean that the band will be open at 5° at any particular hour, on a particular day, in a particular month, in any particular year. In fact, however, experience agrees with the *IONCAP* computations: the 20-meter path to Europe from New England usually opens at a low angle in the morning hours, rising to about 11° during the afternoon, when the signals remain strongest throughout the afternoon until the evening.

Now see Fig 18. Just because 5° is the statistically most prevalent angle (occurring some 13% of the time) from Seattle to Europe on 20 meters, this doesn’t mean that the actual



**Fig 18—Graph showing 20-meter percentage of all openings, this time from Seattle, WA, to Europe, together with overlay of elevation patterns over flat ground for three 20-meter antenna systems. The statistically most likely angle on this path is 5°, occurring about 13% of the time when the band is actually open. Higher antennas predominate on this path.**



**Fig 19—Graph showing 20-meter percentage of all openings from Chicago to Southern Africa, together with overlay of elevation patterns over flat ground for three 20-meter antenna systems. On this long-distance path, higher antennas are most effective.**

angle at any particular moment in time might not be 10°, or even 2°. The statistics for W7 to Europe say that 5° is the most likely angle, but 20-meter signals from Europe arrive at angles ranging from 1° to 16°. If you design an antenna system to cover all possible angles needed to talk to Europe from Seattle (or from Seattle to Europe) on 20 meters, you would need to cover the full range from 1° to 16° equally well.

Similarly, if you wish to cover the full range of elevation angles from Chicago to Southern Africa on 15 meters, you would need to cover 1° to 14°, even though the most statistically likely signals arrive at 1°, for 16% of the time when the band is open for that path. See Fig 19.

## DRAWBACKS OF COMPUTER MODELS FOR ANTENNAS OVER REAL TERRAIN

Modern general-purpose antenna modeling programs such as *NEC* or *MININEC* (or their commercially upgraded equivalents, such as *NEC/Wires* or *EZNEC*) can accurately model almost any type of antenna commonly used by radio amateurs. In addition, there are specialized programs specifically designed to model Yagis efficiently, such as *YO*, *YW* (*Yagi for Windows*, included on the CD-ROM with this book) or *YagiMax*. These programs however are all unable to model antennas accurately over anything other than *purely flat ground*.

While both *NEC* and *MININEC* can simulate irregular ground terrain, they do so in a decidedly crude manner, employing step-like concentric rings of height around an antenna. The documentation for *NEC* and *MININEC* both clearly state that diffraction off these “steps” is not modeled. Common experience among serious modelers is that the warnings in the manuals are well worth heeding!

Although analysis and even optimization of antenna designs can be done using free-space or flat-earth ground models, it is *diffraction* that makes the real world a very, very complicated place indeed. This should be clarified—diffraction is hard, even tortuous, to analyze properly, but it makes analysis of real world results far more believable than a flat-world reflection model does.

## RAY-TRACING OVER UNEVEN LOCAL TERRAIN

### The Raytracing Technique

First, let’s look at a simple raytracing procedure involving only horizontally polarized reflections, with no diffractions. From a specified height on the tower, an antenna shoots “rays” (just as though they were bullets) in 0.25° increments from +35° above the horizon to –35° below the horizon. Each ray is traced over the foreground terrain to see if it hits the ground at any point on its travels in the direction of interest. If it does hit the ground, the ray is reflected following the classical “law of reflection.” That is, the outgoing angle equals the incoming angle, reflected through the normal to the slope of the surface. Once the rays exit into the ionosphere, the individual contributions are vector-summed to create the overall far-field elevation pattern.

The next step in terrain modeling involves adding diffractions as well as reflections. At the Dayton antenna forum in 1994, Jim Breakall, WA3FET, gave a fascinating and tantalizing lecture on the effect of foreground terrain. Later Breakall, Dick Adler, K3CXZ, Joel Young and a group of other researchers published an extremely interesting paper entitled “The Modeling and Measurement of HF Antenna Skywave Radiation Patterns in Irregular Terrain” in the July 1994 *IEEE Transactions on Antennas and Propagation*. They described in rather general terms the modifications they made to the *NEC-BSC* program. They showed how the addition of a ray-tracing reflection and diffraction model to the simplistic stair-stepped reflection model in regular *NEC* gave far more realistic results. For validation, they compared

actual pattern measurements made on a site in Utah (with an overflying helicopter) to computed patterns made using the modified *NEC* software. However, because the work was funded by the US Navy, the software was, and still is, a military secret.

## Thumbnail History of the Uniform Theory of Diffraction

It is instructive to look briefly at the history of how “Geometric Optics” (GO) evolved (and still continues to evolve) into the “Uniform Theory of Diffraction” (UTD). The following is summarized from the historical overview in one book found to be particularly useful and comprehensive on the subject of UTD: *Introduction to the Uniform Geometrical Theory of Diffraction*, by McNamara, Pistorius and Malherbe.

Many years before the time of Christ, the ancient Greeks studied optics. Euclid is credited with deriving the law of reflection about 300 BC. Other Greeks, such as Ptolemy, were also fascinated with optical phenomena. In the 1600s, a Dutchman named Snell finally figured out the law of refraction, resulting in *Snell’s law*. By the early 1800s, the basic world of classical optics was pretty well described from a mathematic point of view, based on the work of a number of individuals.

As its name implies, classical geometric optical theory deals strictly with geometric shapes. Of course, the importance of geometry in optics shouldn’t be minimized—after all, we wouldn’t have eyeglasses without geometric optics. Mathematical analysis of shapes utilizes a methodology that traces the paths of straight-line *rays* of light. (Note that the paths of rays can also be likened to the straight-line paths of particles.) In classical geometric optics, however, there is no mention of three important quantities: phase, intensity and polarization. Indeed, without phase, intensity or polarization, there is no way to deal properly with the phenomenon of *interference*, or its cousin, *diffraction*. These phenomena require theories that deal with *waves* rather than rays.

Wave theory has also been around for a long time, although not as long as geometry. Workers like Hooke and Grimaldi had recorded their observations of interference and diffraction in the mid 1600s. Huygens had used elements of wave theory in the late 1600s to help explain refraction. By the late 1800s, the work of Lord Rayleigh, Sommerfeld, Fresnel, Maxwell and many others led to the full mathematic characterization of all electromagnetic phenomena, light included.

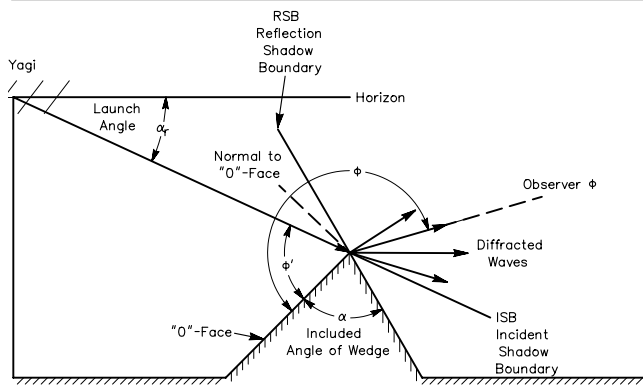
Unfortunately, ray theory doesn’t work for many problems, at least ray theory in the classical optical form. The real world is a lot more jagged, pointy and fuzzy in shape than can be described in a totally rigorous mathematic fashion. Some properties of the real world are most easily explained on the micro level using electrons and protons as conceptual objects, while other macro phenomena (like resonance, for example) are more easily explained in terms of waves. To get a handle on a typical real-world physical situation, a combination of classical ray theory and wave theory was needed.

The breakthrough in the combination of classical geometric optics and wave concepts came from J. B. Keller of Bell Labs in 1953, although he published his work in the early 1960s. In the very simplest of terms, Keller introduced the notion that shooting a ray at a diffraction “wedge” causes wave interference at the tip, with an infinite number of diffracted waves emanating from the diffraction point. Each diffracted wave can be considered to be a point source radiator at the place of generation, the diffraction point. Thereafter, the paths of individual waves can be traced as though they were individual classical optic rays again. What Keller came up with was a reasonable mathematical description of what happens at the tip of the diffraction wedge.

**Fig 20** is a picture of a simple diffraction wedge, with an incoming ray launched at an angle of  $\alpha_r$ , referenced to the horizon, impinging on it. The diffraction wedge here is considered to be perfectly conducting, and hence impenetrable by the ray. The wedge generates an infinite number of diffracted waves, going in all directions not blocked by the wedge itself. The amplitudes and phases of the diffracted waves are determined by the interaction at the wedge tip, and this in turn is governed by the various angles associated with the wedge. Shown in Fig 20 are the included angle  $\alpha$  of the wedge, the angle  $\phi'$  of the incoming ray (referenced to the incoming surface of the wedge), and the observed angle  $\phi$  of one of the outgoing diffracted waves, also referenced to the wedge surface.

The so-called “shadow boundaries” are also shown in Fig 20. The Reflection-Shadow Boundary (RSB) is the angle beyond which no further reflections can take place for a given incoming angle. The Incident-Shadow Boundary (ISB) is that angle beyond which the wedge’s face blocks any incident rays from illuminating the observation point.

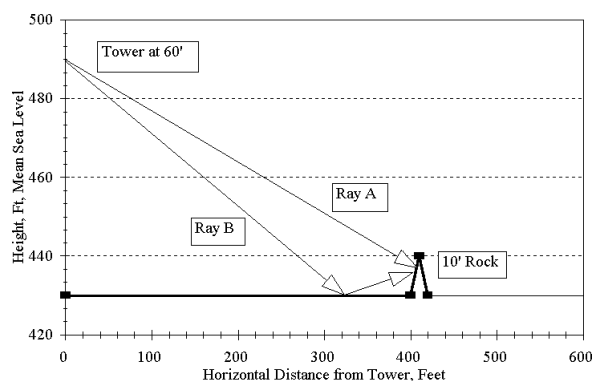
Keller derived the amplitude and phase terms by comparing the classical Geometric Optics (GO) solution with the exact mathematical solution calculated by Sommerfeld



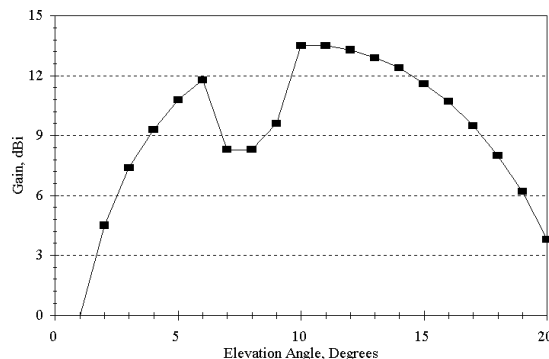
**Fig 20**—Diagram showing diffraction mechanism of ray launched at angle  $\alpha_r$  below horizon at diffraction wedge, whose included angle is  $\alpha$ . Referenced to the incident face (the “o-face” as it is called in UTD terminology), the incoming angle is  $\phi'$  (phi prime). The wedge creates an infinite number of diffracted waves. Shown is one whose angle referenced to the o-face is  $\phi$ , the so-called “observation angle” in UTD terminology.

for a particular case where the boundary conditions were well known—an infinitely long, perfectly conducting wedge illuminated by a plane wave. Simply speaking, whatever was left over had to be diffraction terms. Keller combined these diffraction terms with GO terms to yield the total field everywhere.

Keller’s new theory became known as the Geometric Theory of Diffraction (abbreviated henceforth as GTD). The beauty of GTD was that in the regions where classical GO predicted zero fields, the GTD “filled in the blanks,” so to speak. For example, see **Fig 21**, showing the terrain for a hypothetical case, where a 60-foot high 4-element 15-meter Yagi illuminates a wide, perfectly flat piece of ground. A 10-foot high rock has been placed 400 feet away from the tower base in the direction of outgoing rays. **Fig 22** shows



**Fig 21**—Hypothetical terrain exhibiting so-called “10-foot rock effect.” The terrain is flat from the tower base out to 400 feet, where a 10-foot high rock is placed. Note that this forms a diffraction wedge, but that it also blocks direct waves trying to shoot through it to the flat surface beyond, as shown by Ray A. Ray B reflects off the flat surface before it reaches the 10-foot rock, but it is blocked by the rock from proceeding further. A simple Geometric Optics (GO) analysis of this terrain without taking diffraction into account will result in the elevation response shown in Fig 22.



**Fig 22**—Elevation response for rays launched at terrain in Fig 21 from a height of 60 feet using a 4-element Yagi. This was computed using a simple Geometrical Optics (GO) reflection-only analysis. Note the “hole” in the response between 6° to 10° in elevation. It is not reasonable for a 10-foot high rock to create such a disturbance at 21 MHz!

the elevation pattern predicted using reflection-only GO techniques. Due to blockage of the direct wave (A) trying to shoot past the 10-foot high rock, and due to blockage of (B) reflections from the flat ground in front of the rock, there is a “hole” in the smooth elevation pattern.

Now, doesn't it defy common sense to imagine that a single 10-foot high rock will really have such an effect on a 15-meter signal? Keller's GTD took diffraction effects into account to show that waves do indeed sneak past and over the rock to fill in the pattern. The whole GTD scheme is very clever indeed.

However, GTD wasn't perfect. Keller's GTD predicts some big spikes in the pattern, even though the overall shape of the elevation pattern is much closer to reality than a simple GO reflection analysis would indicate. The region right at the RSB and ISB shadow boundaries is where problems are found. The GO terms go to zero at these points because of blockage by the wedge, while Keller's diffraction terms tend to go to infinity at these very spots. In mathematical terms this is referred to as a “caustic problem.” Nevertheless, despite these nasty problems at the ISB and RSB, the GTD provided a remarkably better solution to diffraction problems than did classical GO.

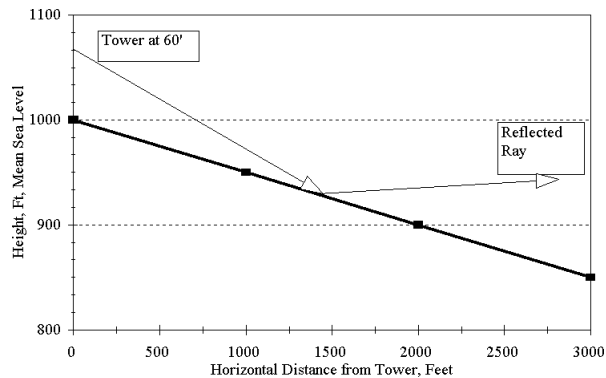
In the early 1970s, a group at Ohio State University under R. G. Kouyoumjian and P. H. Pathak did some pivotal work to resolve this caustic problem, introducing what amounts to a clever “fudge factor” to compensate for the tendency of the diffraction terms at the shadow boundaries to go to infinity. They introduced what is known as a “transition function,” using a form of Fresnel integral. Most importantly, the Ohio State researchers also created several FORTRAN computer programs to compute the amplitude and phase of diffraction components. Now computer hackers could get to work!

The program that resulted is called *YT*, standing for “Yagi Terrain.” As the name suggests, *YT* analyzes the effect of local terrain—for Yagis only, and only for horizontally polarized Yagis. The accurate appraisal of the effect of terrain on vertically polarized signals is a far more complex problem than for horizontally polarized waves.

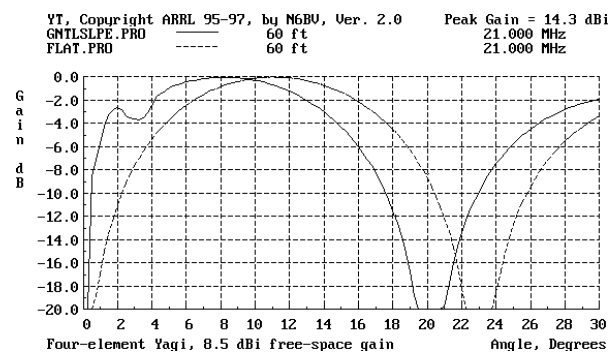
### SIMULATION OF REALITY —SOME SIMPLE EXAMPLES FIRST

We want to focus first on some simple results, to show that the computations do make some sense by presenting some simulations over simple terrains. We've already described the “10-foot rock at 400 feet” situation, and showed where a simple GO reflection analysis is inadequate to the task without taking diffraction effects into account.

Now look at the simple case shown in **Fig 23**, where a very long, continuous downslope from the tower base is shown. Note that the scales used for the X and Y-axes are different: the Y-axis changes 300 feet in height (from 800 to 1100 feet), while the X-axis goes from 0 to 3000 feet. This exaggerates the apparent steepness of the downward slope, which is actually a rather gentle slope, at  $\tan^{-1}(1000 - 850)$



**Fig 23—A long, gentle downward-sloping terrain. This terrain has no explicit diffraction points and can be analyzed using simple GO reflection techniques.**



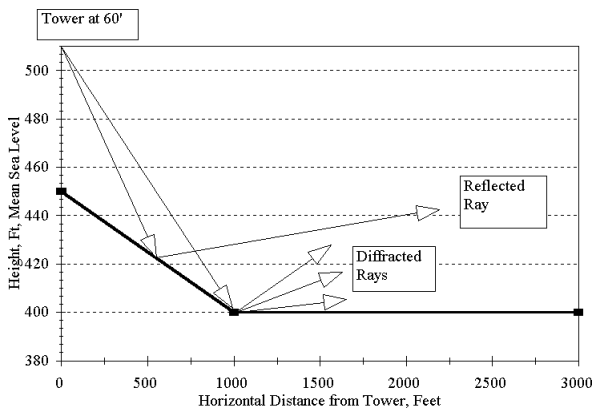
**Fig 24—Elevation response for terrain shown in Fig 23, using a 4-element Yagi, 60-foot high. Note that the shape of the response is essentially shifted toward the left, toward lower elevation angles, by the angle of the sloping ground. For reference, the response for an identical Yagi placed over flat ground is also shown.**

$(3000 - 0) = -2.86^\circ$ . In other words, the terrain falls 150 feet in height over a range of 3000 feet from the base of the tower.

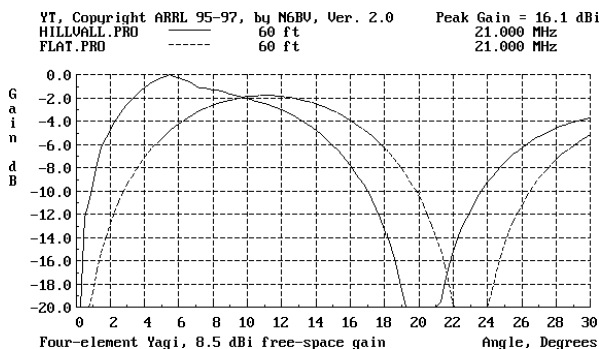
**Fig 24** shows the computed elevation response for this terrain profile, for a four-element horizontally polarized Yagi on a 60 foot tower. The response is compared to that of an identical Yagi placed 60 feet above flat ground. Compared to the “flatland” antenna, the hilltop antenna has an elevation response shifted over by almost  $3^\circ$  toward the lower elevation angles. In fact, this shift is directly due to the  $-2.86^\circ$  slope of the hill. Reflections off the slope are tilted by the slope. In this situation there are no diffractions, just reflections.

Look at **Fig 25**, which shows another simple terrain profile, called a “Hill-Valley” scenario. Here, the 60-foot high tower stands on the edge of a gentle hill overlooking a long valley. Once again the slope of the hill is exaggerated by the different X and Y-axes. **Fig 26** shows the computed

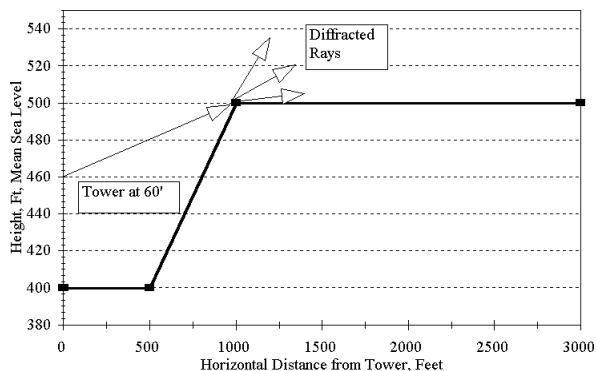




**Fig 25**—“Hill-Valley” terrain, with reflected and diffracted rays.



**Fig 26**—Elevation response computed by YT program for single 4-element Yagi at 60 feet above “Hill-Valley” terrain shown in Fig 25. Note that the slope has caused the response in general to be shifted toward lower elevation angles. At 5° elevation, the diffraction components add up to increase the gain slightly above the amount a GO-only analysis would indicate.



**Fig 27**—“Hill-Ahead” terrain, shown with diffracted rays created by illumination of the edge of the plateau at the top of the hill.

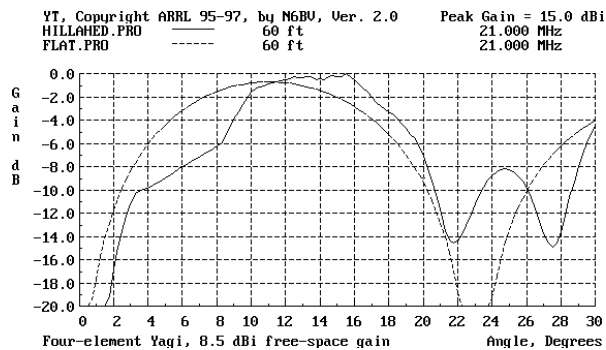
elevation response at 21.2 MHz for a 4-element Yagi on a 60-foot high tower at the edge of the slope.

Once again, the pattern is overlaid with that of an identical 60-foot-high Yagi over flat ground. Compared to the flatland antenna, the hilltop antenna’s response above 9° in elevation is shifted by almost 3° towards the lower elevation angles. Again, this is due to reflections off the downward slope. From 1° to 9°, the hilltop pattern is enhanced even more compared to the flatland antenna, this time by diffraction occurring at the bottom of the hill.

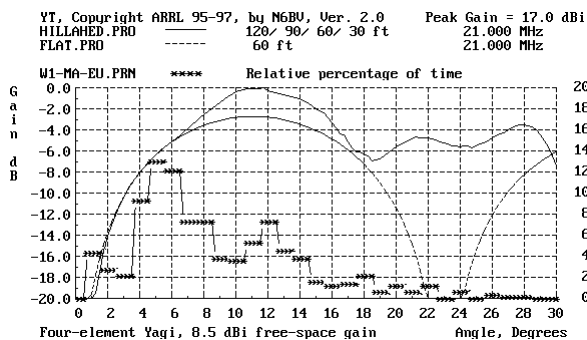
Now let’s see what happens when there is a hill ahead in the direction of interest. Fig 27 depicts such a situation, labeled “Hill-Ahead.” Here, at a height of 400 feet above mean sea level, the land is flat in front of the tower, out to a distance of 500 feet, where the hill begins. The hill then rises 100 feet over the range 500 to 1000 feet away from the tower base. After that, the terrain is a plateau, at a constant 500 feet elevation.

Fig 28 shows the computed elevation pattern for a four-element Yagi 60-feet high on the tower, compared again with an overlay for an identical 60-foot high antenna over flat ground. The hill blocks low-angle waves directly radiated from the antenna from 0° to 2.3°. In addition, waves that would normally be reflected from the ground, and that would normally add in phase from about 2.3° to 12°, are blocked by the hill also. Thus the signal at 8° is down almost 5 dB from the signal over flat ground, all due to the effect of the hill. Diffracted waves start kicking in once the direct wave rises enough above the horizon to illuminate the top edge of the hill. These diffracted waves tend to augment elevation angles above about 12°, which reflected waves can’t reach.

Is there any hope for someone in such a lousy QTH for DXing? Fig 29 shows the elevation response for a truly heroic solution. This involves a stack of four 4-element Yagis, mounted at 120, 90, 60 and 30 feet on the tower. Now, the total gain is just about comparable to that from a single 4-element Yagi mounted over flat ground. Where there’s a ham, there is a way!



**Fig 28**—Elevation response computed by YT for “Hill-Ahead” terrain shown in Fig 27. Now the hill blocks direct rays and also precludes possibility of any constructive reflections. Above 10°, diffraction components add up together with direct rays to create the response shown.



**Fig 29—Elevation response of “heroic effort” to surmount the difficulties imposed by hill in Fig 27. This effort involves a stack of four 4-element Yagis in a stack starting at 120 feet and spaced at 30-foot increments on the tower. The response is roughly equivalent to a single four-element Yagi at 60 feet above flat ground, hence the characterization as being a “heroic effort.” Note that the elevation-angle statistics have been added to this plot as an overlay of asterisks.**

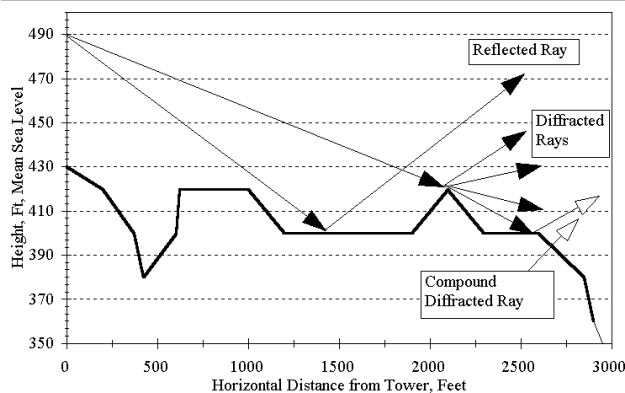
At 5° elevation, four diffraction components add up (there are zero reflection components) to achieve the far-field pattern. This seems reasonable, because each of the four antennas is illuminating the diffraction point separately and we know that none of the four antennas can “see over” the hill directly to produce a reflection at a low launch angle.

You will note something new on Fig 29—another curve has appeared. The line with asterisks refers to the legend “W1-MA-EU.PRN.” This curve portrays the relative percentage of time during which a particular elevation angle arrives in Massachusetts from Europe. We have thus integrated on one graph the range of elevation angles necessary to communicate from New England to Europe (over the whole 11-year sunspot cycle) with the response attributed to the topography of a particular terrain.

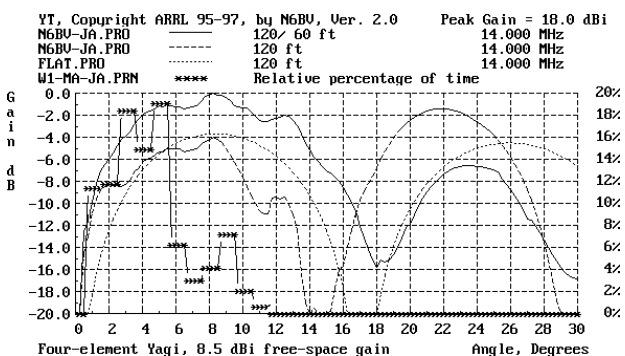
For example, at an elevation angle of 5°, 15-meter signals arrive from Europe about 13% of the total number of times when the band is actually open. We can look at this another way. For about two-thirds of the times when the band is open on this path, the incoming angle is between 3° to 12°. For about one-third of the time, signals arrive above 10°, where the “heroic” four-stack is finally beginning to come into its own, sort of, anyway.

### A More Complex Terrain

The results for simple terrains look reasonable; let’s try a more complicated real-world situation. Fig 30 shows the terrain from the N6BV QTH toward Japan. The terrain is complex, with 17 different points *YT* identifies as diffraction points. Fig 31 shows the *YT* output for three different types of antennas on 20 meters: a stack at 120 and 60 feet, the 120-foot antenna by itself, and then a 120-foot high antenna over flat ground, for reference. The elevation-angle statistics for New England to the Far East (Japan) are overlaid on the graph also, making for a very complicated looking picture—it is a *lot* easier to decipher the lines on



**Fig 30—Terrain of N6BV in Windham, New Hampshire, toward Japan. *YT* identifies 17 different points where diffraction can occur.**



**Fig 31—Elevation responses computed by *YT* for N6BV terrain shown in Fig 30, for a stack of two 4-element Yagis at 120 and 60 feet, together with the response for a single Yagi at 120 feet. The response due to many diffraction and reflection components is complicated! The response for a single four-element Yagi over flat ground is shown by the light dotted line, for reference.**

the color CRT, by the way, than on a black-and-white printer.

Examination of the detailed data output from *YT* shows that at an elevation angle of 5°, the peak percentage angle (19% of the time when the band is open), there are three reflection components for the 120/60-foot stack, but there are also 25 diffraction components! There are many, many signals bouncing around off the terrain on their trip to Japan. Note that because of blockage of some parts of the terrain, the 60-foot high Yagi cannot illuminate all the diffraction points, while the higher 120-foot Yagi is able to “see” these diffraction points.

It is fascinating to reflect on the thought that received signals coming down from the ionosphere to the receiver are having encounters with the terrain, but from the opposite direction. It’s not surprising, given these kinds of interactions, that transmitting and receiving might not be totally reciprocal.

It is interesting that the 120/60-foot stack, indicated by the solid line in Fig 31, achieves its peak gain of 18.0 dBi at 8° elevation, where it is about 4 dB greater than

the single 120-foot high four-element Yagi. At 11° elevation, the difference is about 7 dB in favor of the stack. Numerous times such a marked difference in performance between the stack and each antenna by itself have been observed. Such performance differences due to complex terrain may in fact partly account for why stacks often seem to be “magic” compared to single Yagis at comparable heights.

Certainly there is no way a two-beam stack can actually achieve a 7 dB difference in gain over a single antenna due to stacking alone. Computer modeling over flat ground indicates a maximum practical gain difference on the order of 2.5 to 3 dB, depending on the spacing and interaction between individual Yagis in a stack of two—the uneven terrain is giving the additional focusing gain. Note that you still don’t get something for nothing. While gain at particular angles may be enhanced by terrain focusing, gain at other angles is degraded compared to a flat-ground terrain.

Much of the time when comparisons are being made, the small differences in signal are difficult to measure meaningfully, especially when the QSB varies signals by 20 dB or so during a typical QSO.

### USING YT Generating a Terrain Profile

The program uses two distinct algorithms to generate

the far-field elevation pattern. The first is a simple reflection-only Geometric Optics (GO) algorithm. The second is the diffraction algorithm using the Uniform Theory of Diffraction (UTD). These algorithms work with a digitized representation of the terrain profile for a single azimuthal direction—for example, toward Japan or toward Europe.

The terrain file is generated manually using a topographic map and a ruler or a pair of dividers. The YT.TXT file on the accompanying CD-ROM gives complete instructions on how to create a terrain file. The process is simple for people in the USA. Mark on the US Geological Survey 7.5 minute map the exact location of your tower. You will find 7.5 minute maps available from some local sources, such as large hardware stores, but the main contact point is the U.S. Geological Survey, Denver, CO 80225 or Reston, VA 22092. Call 1-800-MAPS-USA. Ask for the folder describing the topographic maps available for your geographic area. Many countries outside the USA have topographic charts also. Most are calibrated in meters, however. To use these with *TA*, you will have to convert meters to feet by multiplying meters by 3.28.

Mark off a pencil line from the tower base, in the azimuthal direction of interest, perhaps 45° from New England to Europe, or 335° to Japan. Then measure the distance from the tower base to each height contour crossed by the pencil line. Enter the data at each distance/height into

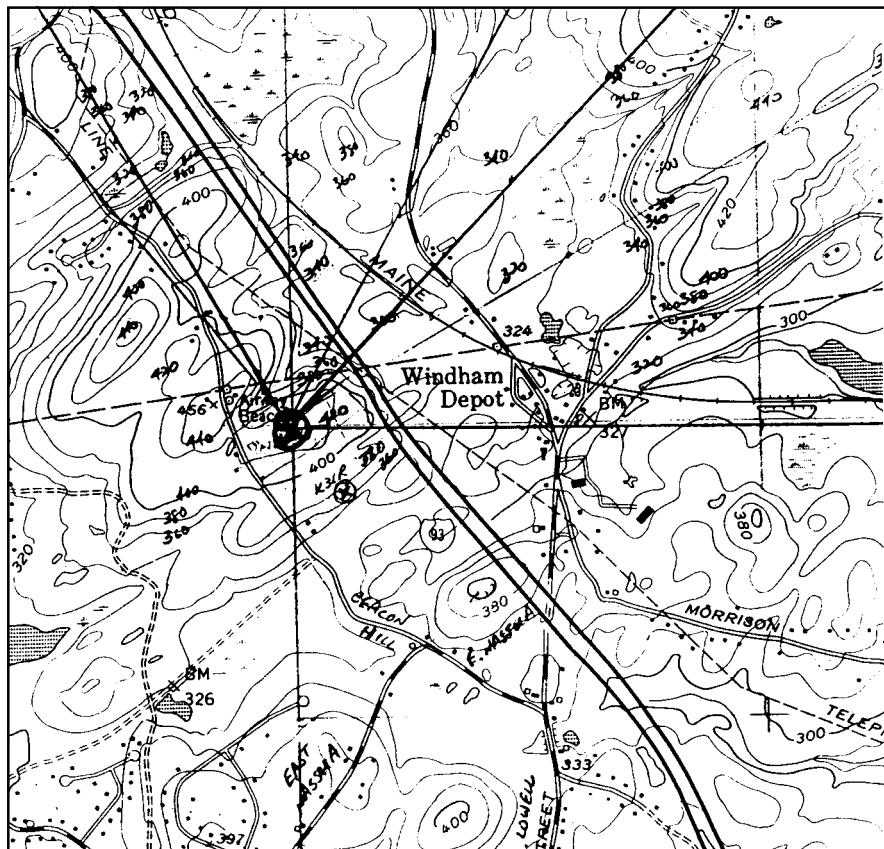


Fig 32—A portion of USGS 7.5 minute topographic map, showing N6BV QTH, together with marks in direction of Europe and Japan from tower base. Note that the elevation contours were marked by hand to help eliminate confusion. This required a magnifying glass and a steady hand!

an ASCII computer file, whose filename extension is “PRO,” standing for “profile.”

**Fig 32** shows a portion of the USGS map for the N6BV QTH in Windham, NH, along with lines scribed in several directions toward various parts of Europe and the Far East. Note that the elevation heights of the intermediate contour lines are labeled manually in pencil in order to make sense of things. It is very easy to get confused unless you do this!

The terrain model used by *YT* assumes that the terrain is represented by flat “plates” connecting the elevation points in the \*.PRO file with straight lines. The model is two dimensional, meaning that range and elevation are the only data for a particular azimuth. In effect, *YT* assumes that the width of a terrain plate is wide relative to its length. Obviously, the world is three dimensional. If your shot in a particular direction involves aiming your Yagi down a canyon with steep walls, then it’s pretty likely that your actual elevation pattern will be different from what *YT* tells you. The signals must careen horizontally from wall to wall, in addition to being affected by the height changes of the terrain. *YT* isn’t designed to do canyons.

To get a true 3-D picture of the full effects of terrain, a terrain model would have to show azimuth, along with range and elevation, point-by-point for about a mile in every direction around the base of the tower. After you go through the pain of manually creating a profile for a single azimuth, you’ll appreciate the immensity of the process if you try to create a full 360° 3-D profile.

Digital terrain maps are available in some locations. However, be cautioned that the digitized data from such databases is fairly crude in resolution. No doubt, the data is adequate to keep a Cruise Missile flying above the terrain, one of the original intents for digitized terrain data. The data is probably adequate for many other non-military purposes too. But it is rarely sufficiently detailed to be truly representative of what your antenna looks down at from the tower.

### Algorithm for Ray-Tracing the Terrain

There are a number of mechanisms that should be taken into account as a ray travels over the terrain:

1. Classical ray reflection, with Fresnel ground coefficients.
2. Direct diffraction, where a diffraction point is illuminated directly by an antenna, with no intervening terrain features blocking the direct illumination.
3. When a diffracted ray is subsequently reflected off the terrain.
4. When a reflected ray encounters a diffraction point and causes another series of diffracted rays to be generated.
5. When a diffracted ray hits another diffraction point, generating another whole series of diffractions.

Certain unusual, bowl-shaped terrain profiles, with sheer vertical faces, can conceivably cause signals to reflect or diffract in a backward direction, only to be reflected back again in the forward direction by the sheer-walled terrain to the rear.

*YT* does not accommodate these interactions, mainly because to do so would increase the computation time too much.

### *YT*’s Internal Antenna Model

The Yagi antenna used inside *YT* can be selected by the operator to be anywhere from a 2-element to an 8-element Yagi. The default assumes a simple cosine-squared response equivalent to a 4-element Yagi in free space. *YT* traces rays only in the forward direction from the tower along the azimuth of interest. This keeps the algorithms reasonably simple and saves computing time, while minimizing memory requirements. Since the Yagi model assumes that the antenna has a decent front-to-back ratio, there is no need to worry about signals bouncing off the terrain behind the tower, something that would be necessary for a dipole, for example.

*YT* considers each Yagi in a stack as a separate point source. The simulation begins to fall apart if a traveling wave type of antenna like a rhombic is used, particularly if the terrain changes under the antenna—that is, the ground is not flat under the entire antenna. For a typical Yagi, even a long-boom one, the point-source assumption is reasonable. The internal antenna model also assumes that the Yagi is horizontally polarized. *YT* does not do vertically polarized antennas.

*YT* compares well with the measurements for the horizontal antennas described earlier by Jim Breakall, WA3FET, using a helicopter in Utah. Breakall’s measurements were done with a 15-foot high horizontal dipole.

### More Details About *YT*

#### *Frequency Coverage*

*YT* can be used on frequencies higher than the HF bands, although the graphical resolution is only 0.25°. The patterns above about 100 MHz thus look rather grainy. The UTD is a “high-frequency asymptotic” solution, so in theory the results get more realistic as the frequency is raised. Keep in mind too that *YT* is designed to model launch angles for skywave propagation modes, including F-layer and even sporadic E. Since by definition the ionospheric launch angles include only those above the horizon, direct line-of-sight UHF modes involving negative launch angles are not considered in *YT*.

See *YT.TXT* for further details on the operation of the *YT* program. This file, as well as sample terrain profiles for “big-gun” stations, is located on the CD-ROM accompanying this book.

### BIBLIOGRAPHY

Source material and more extended discussion of the topics covered in this chapter can be found in the references listed below and in the textbooks listed at the end of [Chapter 2](#).

B. Boothe, “The Minooka Special,” *QST*, Dec 1974.

Brown, Lewis and Epstein, “Ground Systems as a Factor in Antenna Efficiency,” *Proc. IRE*, Jun 1937.

- R. Jones, "A 7-MHz Vertical Parasitic Array," *QST*, Nov 1973.
- D. A. McNamara, C. W. I. Pistorius, J. A. G. Malherbe, *Introduction to the Geometrical Theory of Diffraction* (Norwood, MA: Artech House, 1994).
- C. J. Michaels, "Some Reflections on Vertical Antennas," *QST*, Jul 1987.
- C. J. Michaels, "Horizontal Antennas and the Compound Reflection Coefficient," *The ARRL Antenna Compendium Vol 3* (Newington: ARRL, 1992).
- J. Sevick, "The Ground-Image Vertical Antenna," *QST*, Jul 1971.
- J. Sevick, "The W2FMI 20-Meter Vertical Beam," *QST*, Jun 1972.
- J. Sevick, "The W2FMI Ground-Mounted Short Vertical," *QST*, Mar 1973.
- J. Sevick, "A High Performance 20-, 40- and 80-Meter Vertical System," *QST*, Dec 1973.
- J. Sevick, "The Constant-Impedance Trap Vertical," *QST*, Mar 1974.
- J. Stanley, "Optimum Ground Systems for Vertical Antennas," *QST*, Dec 1976.
- F. E. Terman, *Radio Engineers' Handbook*, 1st ed. (New York, London: McGraw-Hill Book Co, 1943).
- Radio Broadcast Ground Systems*, available from Smith Electronics, Inc, 8200 Snowville Rd, Cleveland, OH 44141.

The last major study that appeared in the amateur literature on the subject of local terrain as it affects DX appeared in four *QST* "How's DX" columns, by Clarke Greene, K1JX, from October 1980 to January 1981. Greene's work was an update of a landmark September 1966 *QST* article entitled "Station Design for DX," by Paul Rockwell, W3AFM. The long-range profiles of several prominent, indeed legendary, stations in Rockwell's article are fascinating: W3CRA, W4KFC and W6AM.

# Chapter 4

# Antenna System Planning and Practical Considerations

## Selecting Your Antenna System

Where should you start in putting together an antenna system? A newcomer to Amateur Radio, an amateur moving to a new location, or someone wanting to improve an existing “antenna farm” might ask this question. The answer: In a comfortable chair, with a pad and writing instrument.

The most important time spent in putting together an antenna system is that time spent in planning. It can save a lot of time, money and frustration. While no one can tell you the exact steps you should take in developing your master plan, this section, prepared by Chuck Hutchinson, K8CH, should help you with some ideas.

Begin planning by spelling out your communications desires. What bands are you interested in? Who (or where) do you want to talk to? When do you operate? How much time and money are you willing to spend on an antenna system? What physical limitations affect your master plan?

From the answers to the above questions, begin to formulate goals—short, intermediate, and long range. Be realistic about those goals. Remember that there are three station effectiveness factors that are under your control. These are: operator skill, equipment in the shack, and the antenna system. There is no substitute for developing operating skills. Some trade-offs are possible between shack equipment and antennas. For example, a high-power amplifier can compensate for a less than optimum antenna. By contrast, a better antenna has advantages for receiving as well as for transmitting.

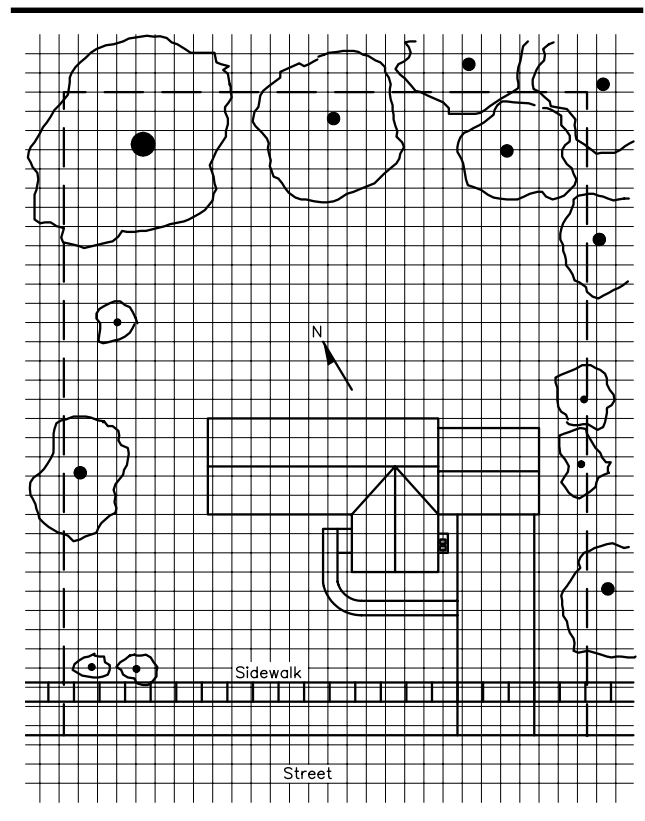
Consider your limitations. Are there regulatory restrictions on antennas in your community? Are there any deed restrictions or covenants that apply to your property? Do other factors (finances, family considerations, other interests, and so forth) limit the type or height of antennas that you can erect? All of these factors must be investigated because they play a major role determining the type of antennas you erect.

Chances are that you won't be able to immediately do all you desire. Think about how you can budget your resources over a period of time. Your resources are your money, your time available to work, materials you may have on hand, friends that are willing to help, etc. One way to budget is to concentrate your initial efforts on a given band or two. If your major interest is in chasing DX, you might want to start with a very good antenna for the 14-MHz band. A simple

multiband antenna could initially serve for other frequencies. Later you can add better antennas for those other bands.

### SITE PLANNING

A map of your property or proposed antenna site can be of great help as you begin to consider alternative antennas. You'll need to know the size and location of buildings, trees and other major objects in the area. Be sure to note compass directions on your map. Graph paper or quadrille paper is very useful for this purpose. See **Fig 1** for an example. It's a good idea to make a few photocopies of your site map so you can mark on the copies as you work on your plans.



**Fig 1**—A site map such as this one is a useful tool for planning your antenna installation.

Use your map to plan antenna layouts and locations of any supporting towers or masts. If your plan calls for more than one tower or mast, think about using them as supports for wire antennas. As you work on a layout, be sure to think in three dimensions even though the map shows only two.

Be sensitive to your neighbors. A 70-foot guyed tower in the front yard of a house in a residential neighborhood is not a good idea (and probably won't comply with local ordinances!).

## ANALYSIS

Use the information in this book to analyze antenna patterns in both horizontal and vertical planes. If you want to work DX, you'll want antennas that radiate energy at low angles. An antenna pattern is greatly affected by the presence of ground. Therefore, be sure to consider what effect ground will have on the antenna pattern at the height you are considering. A 70-foot high antenna is approximately  $\frac{1}{2}$ , 1,  $1\frac{1}{2}$  and 2 wavelengths ( $\lambda$ ) high on 7, 14, 21 and 28 MHz respectively. Those heights are useful for long-distance communications. The same 70-foot height represents only  $\lambda/4$  at 3.5 MHz. Most of the radiated energy from a dipole at that height would be concentrated straight up. This condition is not great for long-distance communication, but can still be useful for DX work and excellent for short-range communication.

Lower heights can be useful for communication. However, it is generally true that "the higher, the better" as far as communications effectiveness is concerned.

There may be cases where it is not possible to install low-frequency dipoles at  $\lambda/4$  or more above the ground. A vertical antenna with many radials is a good choice for long-distance communications. You may want to install both a dipole and a vertical for the 3.5 or 7-MHz bands. On the 1.8-MHz band, unless very tall supports are available, a vertical antenna is likely to be the most useful for DXing. You can then choose the antenna that performs best for a given set of conditions. A low dipole will generally work better for shorter-range communications, while the vertical will generally be the better performer over longer distances.

Consider the azimuthal pattern of fixed antennas. You'll want to orient any fixed antennas to favor the directions of greatest interest to you.

## BUILDING THE SYSTEM

When the planning is completed, it is time to begin construction of the antenna system. Chances are that you can divide that construction into a series of phases or steps. Say, for example, that you have lots of room and that your long-range plan calls for a pair of 100-foot towers to support monoband Yagi antennas. The towers will also support a horizontal 3.5-MHz dipole at 100 feet, for DX work. On your map you've located them so the dipole will be broadside to Europe. Initially you decide to build a 60-foot tower with a tribander beam and a 3.5-MHz inverted-V dipole to begin the project. In your master plan, the 60-foot tower is really

the bottom part of a 100-foot tower. The guys, anchors and all hardware are designed for use in the 100 footer.

Initially you buy a heavy-duty rotator and mast that will be needed for the monoband antennas later. Thus, you avoid having to buy, and then sell, a medium-duty rotator and lighter-weight tower equipment. You could have saved money in the long run by putting up a monoband beam for your favorite band, but you decided that for now it is more important to have a beam on 14, 21 and 28 MHz. The second step of your plan calls for installing the second tower. This time you've decided to wait until you can install all 100 feet of that second tower, and put a 7-MHz Yagi on top of it. Later you will remove the top section of the first (60 foot) tower and insert the sections and add the guys to bring it up to 100 feet. You decide that at that time you'll continue to use the tribander for a few months to see what difference the 60 foot to 100-foot height change makes.

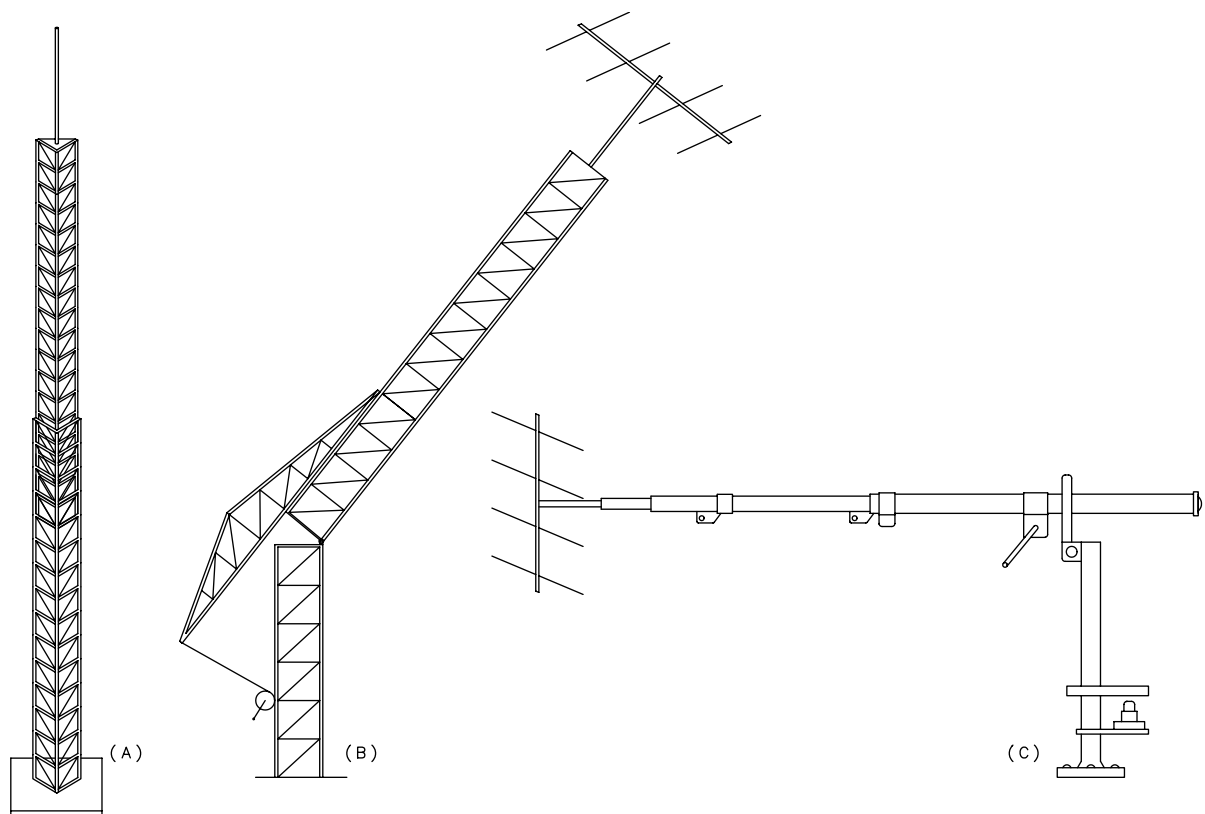
## COMPROMISES

Because of limitations, most amateurs are never able to build their "dream" antenna system. This means that some compromises must be made. Do not, under any circumstances, compromise the safety of an antenna installation. Follow the manufacturer's recommendations for tower assembly, installation and accessories. Make sure that all hardware is being used within its ratings.

Guyed towers are frequently used by radio amateurs because they cost less than more complicated unguyed or freestanding towers with similar ratings. Guyed towers are fine for those who can climb, or those with a friend who is willing to climb. But you may want to consider an antenna tower that folds over, or one that cranks up (and down). Some towers crank up (and down) and fold over too. See [Fig 2](#). That makes for convenient access to antennas for adjustments and maintenance without climbing. Crank-up towers also offer another advantage. They allow antennas to be lowered during periods of no operation, such as for aesthetic reasons or during periods of high winds.

A well-designed monoband Yagi should out-perform a multiband Yagi. In a monoband design the best adjustments can be made for gain, front-to-back ratio (F/B), and matching, but only for a single band. In a multiband design, there are always trade-offs in these properties for the ability to operate on more than one band. Nevertheless, a multiband antenna has many advantages over two or more single band antennas. A multiband antenna requires less heavy duty hardware, requires only one feed line, takes up less space, and it costs less.

Apartment dwellers face much greater limitations in their choice of antennas. For most, the possibility of a tower is only a dream. (One enterprising ham made arrangements to purchase a top-floor condominium from a developer. The arrangements were made before construction began, and the plans were altered to include a roof-top tower installation.) For apartment and condominium dwellers, the situation is still far from hopeless. A later section presents ideas for consideration.



**Fig 2—**Alternatives to a guyed tower are shown here. At A, the crank-up tower permits working on antennas at reduced height. It also allows antennas to be lowered during periods of no operation. Motor-driven versions are available. The fold-over tower at B and the combination at C permit working on antennas at ground level.

### EXAMPLES

You can follow the procedure previously outlined to put together modest or very large antenna systems. What might a ham put together for antennas when he or she wants to try a little of everything, and has a modest budget? Let's suppose that the goals are (1) low cost, (2) no tower, (3) coverage of all HF bands and the repeater portion of one VHF band, and (4) the possibility of working some DX.

After studying the pages of this book, the station owner decides to first put up a 135-foot center-fed antenna. High trees in the backyard will serve as supports to about 50 feet. This antenna will cover all the HF bands by using a balanced feeder and an antenna tuner. It should be good for DX contacts on 10 MHz and above, and will probably work okay for DX contacts on the lower bands. However, her plan calls for a vertical for 3.5 and 7 MHz to enhance the DX possibilities on those bands. For VHF, a chimney-mounted vertical is included.

### ANOTHER EXAMPLE

A licensed couple has bigger ambitions. Goals for their station are (1) a good setup for DX on 14, 21 and 28 MHz, (2) moderate cost, (3) one tower, (4) ability to work some DX on 1.8, 3.5 and 7 MHz, and (5) no need to cover the CW portion of the bands.

After considering the options, the couple decides to install a 65-foot guyed tower. A large commercial triband Yagi will be mounted on top of the tower. The center of a trap dipole tuned for the phone portion of the 3.5 and 7-MHz bands will be supported by a wooden yard arm installed at the 60-foot level of the tower, with ends drooping down to form an inverted V. An inverted L for 1.8 MHz starts near ground level and goes up to a similar yard arm on the opposite side of the tower. The horizontal portion of the inverted L runs away from the tower at right angles to the trap dipole. Later, the husband will experiment with sloping antennas for 3.5 MHz. If those experiments are not successful, a  $\lambda/4$  vertical will be used on that band.



# Apartment Possibilities

A complete and accurate assessment of antenna types, antenna placement, and feed-line placement is very important for the apartment dweller. Among the many possibilities for types are balcony antennas, “invisible” ones (made of fine wire), vertical antennas disguised as flag poles or as masts with a TV antenna on top, and indoor antennas.

A number of amateurs have been successful in negotiating with the apartment owner or manager for permission to install a short mast on the roof of the structure. Coaxial lines and rotator control cables might be routed through conduit troughs or through duct work. If you live in one of the upper stories of the building, routing the cables over the edge of the roof and in through a window might be the way to go. There is a story about one amateur who owns a triband beam mounted on a 10-foot mast. But even with such a short mast, he is the envy of all his amateur friends because of his superb antenna height. His mast stands on top of a 22-story apartment building.

Usually the challenge is to find ways to install antennas that are unobtrusive. That means searching out antenna locations such as balconies, eaves, nearby trees, etc. For example, a simple but effective balcony antenna is a dangling vertical. Attach an “invisible” wire to the tip of a mobile whip or a length of metal rod or tubing. Then mount the rigid part of the antenna horizontally on the balcony rail, dangling the wire over the edge. The antenna is operated against the balcony railing or other metallic framework. A matching network is usually required at the antenna feed

point. Metal in the building will likely give a directivity effect, but this may be of little consequence and perhaps even an advantage. The antenna may be removed and stored when not in use.

Frequently, the task of finding an inconspicuous route for a feed line is more difficult than the antenna installation itself. When Al Francisco, K7NHV, lived in an apartment, he used a tree-mounted vertical antenna. The coax feeder exited his apartment through a window and ran down the wall to the ground. Al buried the section of line that went from under the window to a nearby tree. At the tree, a section of enameled wire was connected to the coax center conductor. He ran the wire up the side of the tree away from foot traffic. A few short radials completed the installation. The antenna worked fine, and was never noticed by the neighbors.

See [Chapters 6 and 15](#) for ideas about low-frequency and portable antennas that might fit into your available space. Your options are limited as much by your imagination and ingenuity as by your pocketbook. Another option for apartment dwellers is to operate away from home. Some hams concentrate on mobile operation as an alternative to a fixed station. It is possible to make a lot of contacts on HF mobile. Some have worked DXCC that way.

Suppose that you like VHF contests. Because of other activities, you are not particularly interested in operating VHF outside the contests. Why not take your equipment and antennas to a hilltop for the contests? Many hams combine a love for camping or hiking with their interest in radio.

## Antennas for Limited Space

It is not always practical to erect full-size antennas for the HF bands. Those who live in apartment buildings may be restricted to the use of minuscule radiators because of house rules, or simply because the required space for full-size antennas is unavailable. Other amateurs may desire small antennas for aesthetic reasons, perhaps to keep peace with neighbors who do not share their enthusiasm about high towers and big antennas. There are many reasons why some amateurs prefer to use physically shortened antennas; this chapter discusses proven designs and various ways of building and using them effectively.

Few compromise antennas are capable of delivering the performance one can expect from the full-size variety. But the patient and skillful operator can often do as well as some who are equipped with high power and full-size antennas. Someone with a reduced-size antenna may not be able to “bore a hole” in the bands as often, and with the commanding dispatch enjoyed by those who are better

equipped, but DX can be worked successfully when band conditions are suitable.

### INVISIBLE ANTENNAS

We amateurs don’t regard our antennas as eyesores; in fact, we almost always regard them as works of art! But there are occasions when having an outdoor or visible antenna can present problems.

When we are confronted with restrictions-self-imposed or otherwise-we can take advantage of a number of options toward getting on the air and radiating at least a moderately effective signal. In this context, a poor antenna is certainly better than no antenna at all! This section describes a number of techniques that enable us to use indoor antennas or “invisible” antennas outdoors. Many of these systems will yield good-to-excellent results for local and DX contacts, depending on band conditions at any given time. The most important consideration is that of not erecting any antenna

that can present a hazard (physical or electrical) to humans, animals and buildings. Safety first!

### Clothesline Antenna

Clotheslines are sometimes attached to pulleys (Fig 3) so that the user can load the line and retrieve the laundry from a back porch. Laundry lines of this variety are accepted parts of the neighborhood “scenery,” and can be used handily as amateur antennas by simply insulating the pulleys from their support points. This calls for the use of a conducting type of clothesline, such as heavy gauge stranded electrical wire with Teflon or vinyl insulation. A high quality, flexible steel cable (stranded) is suitable as a substitute if one doesn’t mind cleaning it each time clothing is hung on it.

A jumper wire can be brought from one end of the line to the ham shack when the station is being operated. If a good electrical connection exists between the wire clothesline and the pulley, a permanent connection can be made by connecting the lead-in wire between the pulley and its insulator. An antenna tuner can be used to match the “invisible” random-length wire to the transmitter and receiver.

### Invisible Long Wire

A wire antenna is not actually a “long wire” unless it is one wavelength or greater in length. Yet many amateurs refer to (relatively) long physical spans of conductor as “long wires.” For the purpose of this discussion we will assume we have a fairly long span of wire, and refer to it as an “end-fed” wire antenna.

If we use small-diameter enameled wire for our end-fed antenna, chances are that it will be very difficult to see against the sky and neighborhood scenery. The smaller the wire, the more “invisible” the antenna will be. The limiting factor with small wire is fragility. A good compromise is #24 or #26 magnet wire for spans up to 130 feet; lighter-gauge wire can be used for shorter spans, such as 30 or 60 feet. The major threat to the longevity of fine wire is icing. Also, birds may fly into the wire and break it. Therefore, this style of antenna may require frequent service or replacement.

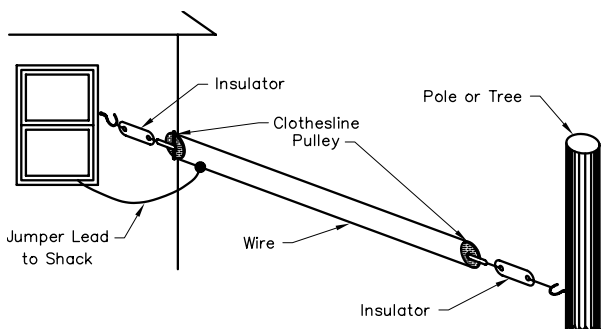


Fig 3—The clothesline antenna is more than it appears to be.

Fig 4 illustrates how we might install an invisible end-fed wire. It is important that the insulators also be lacking in prominence. Tiny Plexiglas blocks perform this function well. Small-diameter clear plastic medical vials are suitable also. Some amateurs simply use rubber bands for end insulators, but they will deteriorate rapidly from sun and air pollutants. They are entirely adequate for short-term operation with an invisible antenna, however.

### Rain Gutter and TV Antennas

A great number of amateurs have taken advantage of standard house fixtures when contriving inconspicuous antennas. A very old technique is the use of the gutter and down spout system on the building. This is shown in Fig 5, where a lead wire is routed to the operating room from one end of the gutter trough. We must assume that the wood to which the gutter is affixed is dry and of good quality to provide reasonable electrical insulation. The rain gutter antenna may perform quite poorly during wet weather or when there is ice and snow on it and the house roof.

All joints between gutter and down spout sections must

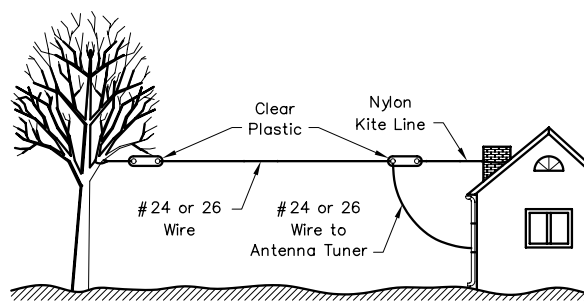


Fig 4—The “invisible” end-fed antenna.

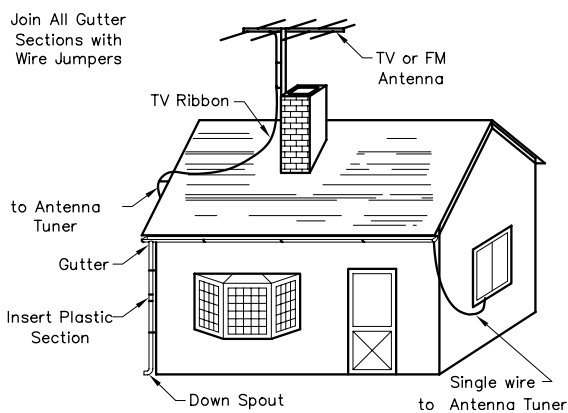


Fig 5—Rain gutters and TV antenna installations can be used as inconspicuous Amateur Radio antennas.

be bonded electrically with straps of braid or flashing copper to provide good continuity in the system. Poor joints can permit rectification of RF and subsequently cause TVI and other harmonic interference. Also, it is prudent to insert a section of plastic down spout about 8 feet above ground to prevent RF shocks or burns to passersby while the antenna is being used. Improved performance may result if the front and back gutters of the house are joined by a jumper wire to increase the area of the antenna.

**Fig 5** also shows a TV or FM antenna that can be employed as an invisible amateur antenna. Many of these antennas can be modified easily to accommodate the 144 or 222-MHz bands, thereby permitting the use of the 300- $\Omega$  line as a feeder system. Some FM antennas can be used on 6 meters by adding #10 bus wire extensions to the ends of the elements, and adjusting the match for an SWR of 1:1. If 300- $\Omega$  line is used it will require a balun or antenna tuner to interface the line with the station equipment.

For operation in the HF bands, the TV or FM antenna feeders can be tied together at the transmitter end of the span and the system treated as a random length wire. If this is done, the 300- $\Omega$  line will have to be on TV standoff insulators and spaced well away from phone and power company service entrance lines. Naturally, the TV or FM radio must be disconnected from the system when it is used for amateur work! Similarly, masthead amplifiers and splitters must be removed from the line if the system is to be used for amateur operation. If the system is mostly vertical, a good RF ground system with many radials around the base of the house should be used to improve performance.

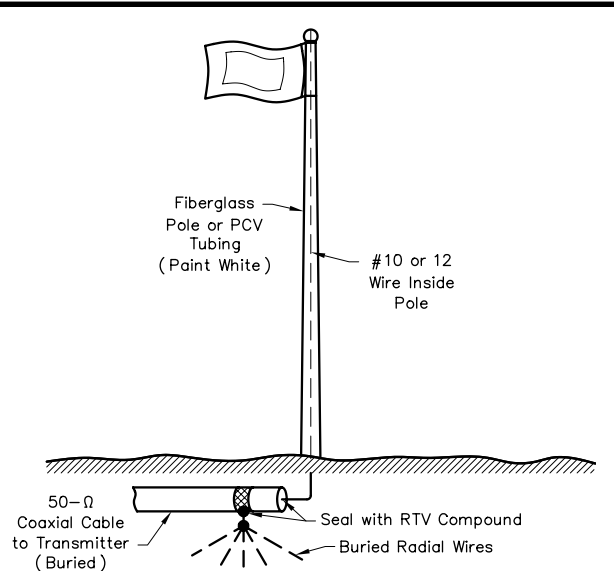
A very nice top-loaded vertical can be made from a length of TV mast with a large TV antenna on the top. Radials can be placed on the roof or at ground level with the TV “feed line” acting as part of the vertical. An extensive discussion of loaded verticals and radial systems is given in **Chapter 6**.

### Flagpole Antennas

We can exhibit our patriotism and have an invisible amateur antenna at the same time by disguising our antenna as shown in **Fig 6**. The vertical antenna is a wire that has been placed inside a plastic or fiberglass pole.

The flagpole antenna shown is structured for a single amateur band, and it is assumed that the height of the pole corresponds to a quarter wavelength for the chosen band. The radials and feed line can be buried in the ground as shown. In a practical installation, the sealed end of the coax cable would protrude slightly into the lower end of the plastic pole.

If a large-diameter fiberglass pole were available, a multiband trap vertical may be concealed inside it. Or we might use a metal pole and bury a water-tight box at its base, containing fixed-tuned matching networks for the bands of interest. The networks could then be selected remotely by means of relays inside the box. A 30-foot flagpole would provide good results in this kind of system, provided it was used in conjunction with a buried radial system.



**Fig 6—A flagpole antenna.**

Still another technique is one that employs a wooden flagpole. A small diameter wire can be stapled to the pole and routed to the coax feeder or matching network. The halyard could by itself constitute the antenna wire if it were made from heavy duty insulated hookup wire. There are countless variations for this type of antenna, and they are limited only by the imagination of the amateur.

### Other Invisible Antennas

Some amateurs have used the metal fence on apartment verandas as antennas, and have had good results on the upper HF bands (14, 21 and 28 MHz). We must presume that the fences were not connected to the steel framework of the building, but rather were insulated by the concrete floor to which they were affixed. These veranda fences have also been used effectively as ground systems (counterpoises) for HF-band vertical antennas put in place temporarily after dark.

One New York City amateur uses the fire escape on his apartment building as a 7-MHz antenna, and reports good success working DX stations with it. Another apartment dweller makes use of the aluminum frame on his living room picture window as an antenna for 21 and 28 MHz. He works it against the metal conductors of the baseboard heater in the same room.

Many jokes have been told over the years about “bedspring antennas.” The idea is by no means absurd. Bedsprings and metal end boards have been used to advantage as antennas by many apartment dwellers as 14, 21, and 28 MHz radiators. A counterpoise ground can be routed along the baseboard of the room and used in combination with the bedspring. It is important to remember that any independent (insulated) metal object of reasonable size can serve as an antenna if the transmitter can be matched to it. An amateur

in Detroit once used his Shopsmith craft machine (about 5 feet tall) as a 28-MHz antenna. He worked a number of DX stations with it when band conditions were good.

A number of operators have used metal curtain rods and window screens for VHF work, and found them to be acceptable for local communication. Best results with any of these makeshift antennas will be had when the “antennas” are kept well away from house wiring and other conductive objects.

## INDOOR ANTENNAS

Without question, the best place for your antenna is outdoors, and as high and in the clear as possible. Some of us, however, for legal, social, neighborhood, family or landlord reasons, are restricted to indoor antennas. Having to settle for an indoor antenna is certainly a handicap for the amateur seeking effective radio communication, but that is not enough reason to abandon all operation in despair.

First, we should be aware of the reasons why indoor antennas do not work well. Principal faults are: (1) low height above ground—the antenna cannot be placed higher than the highest peak of the roof, a point usually low in terms of wavelength at HF, (2) the antenna must function in a lossy RF environment involving close coupling to electrical wiring, guttering, plumbing and other parasitic conductors, besides dielectric losses in such nonconductors as wood, plaster and masonry, (3) sometimes the antenna must be made small in terms of a wavelength and (4) usually it cannot be rotated. These are appreciable handicaps. Nevertheless, global communication with an indoor antenna is still possible, although you must be sure that you are not exposing anyone in your family or nearby neighbors to excessive radiation. See [Chapter 1](#) on Safety.

Some practical points in favor of the indoor antenna include: (1) freedom from weathering effects and damage caused by wind, ice, rain and sunlight (the SWR of an attic antenna, however, can be affected somewhat by a wet or snow-covered roof), (2) indoor antennas can be made from materials that would be altogether impractical outdoors, such as aluminum foil and thread (the antenna need support only its own weight), (3) the supporting structure is already in place, eliminating the need for antenna masts and (4) the antenna is readily accessible in all weather conditions, simplifying pruning or tuning, which can be accomplished without climbing or tilting over a tower.

### Empiricism

A typical house or apartment presents such a complex electromagnetic environment that it is impossible to predict theoretically which location or orientation of the indoor antenna will work best. This is where good old fashioned cut-and-try, use-what-works-best empiricism pays off. But to properly determine what really is most suitable requires an understanding of some antenna measuring fundamentals.

Unfortunately, many amateurs do not know how to evaluate performance scientifically or compare one antenna with another. Typically, they will put up one antenna and try

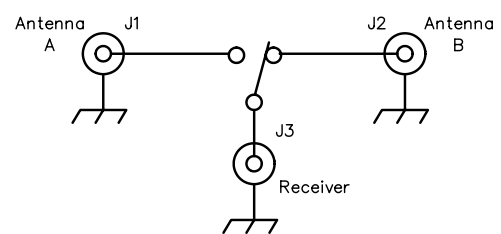
it out on the air to see how it “gets out” in comparison with a previous antenna. This is obviously a very poor evaluation method because there is no way to know if the better or worse reports are caused by changing band conditions, different S-meter characteristics, or any of several other factors that could influence the reports received.

Many times the difference between two antennas or between two different locations for identical antennas amounts to only a few decibels, a difference that is hard to discern unless instantaneous switching between the two is possible. Those few decibels are not important under strong signal conditions, of course, but when the going gets rough, as is often the case with an indoor antenna, a few dB can make the difference between solid copy and no possibility of real communication.

Very little in the way of test equipment is needed for casual antenna evaluation, other than a communications receiver. You can even do a qualitative comparison by ear, if you can switch antennas instantaneously. Differences of less than 2 dB, however, are still hard to discern. The same is true of S-meters. Signal strength differences of less than a decibel are usually difficult to see. If you want that last fraction of a decibel, you should use a good ac voltmeter at the receiver audio output (with the AGC turned off).

In order to compare two antennas, switching the coaxial transmission line from one to the other is necessary. No elaborate coaxial switch is needed; even a simple double throw toggle or slide switch will provide more than 40 dB of isolation at HF. See [Fig 7](#). Switching by means of manually connecting and disconnecting coaxial lines is not recommended because that takes too long. Fading can cause signal-strength changes during the changeover interval.

Whatever difference shows up in the strength of the received signal will be the difference in performance between the two antennas in the direction of that signal. For this test to be valid, both antennas must have nearly the same feed-point impedance, a condition that is reasonably well met if the SWR is below 2:1 on both antennas.



**Fig 7—When antennas are compared on fading signals, the time delay involved in disconnecting and reconnecting coaxial cables is too long for accurate measurements. A simple slide switch will do well for switching coaxial lines at HF. The four components can be mounted in a tin can or any small metal box. Leads should be short and direct. J1 through J3 are coaxial connectors.**

On ionospheric propagated signals (sky wave) there will be constant fading, and for a valid comparison it will be necessary to take an average of the difference between the two antennas. Occasionally, the inferior antenna will deliver a stronger signal to the receiver, but in the long run the law of averages will put the better antenna ahead.

Of course with a ground-wave signal, such as that from a station across town, there will be no fading problems. A ground-wave signal will enable the operator to properly evaluate the antenna under test in the direction of the source. The results will be valid for ionospheric-propagated signals at low elevation angles in that direction. On 28 MHz, all sky-wave signals arrive and leave at low angles. But on the lower bands, particularly 3.5 and 7 MHz, we often use signals propagated at high elevation angles, almost up to the zenith. For these angles a ground-wave test will not provide a proper evaluation of the antenna, and use of sky-wave signals becomes necessary.

### Dipoles

At HF the most practical indoor antenna is usually the dipole. Attempts to get more gain with parasitic elements will usually fail because of close proximity of the ground or coupling to house wiring. Beam antenna dimensions determined outdoors will not usually be valid for an attic antenna because the roof structure will cause dielectric loading of the parasitic elements. It is usually more worthwhile to spend time optimizing the location and performance of a dipole than to try to improve results with parasitic elements.

Most attics are not long enough to accommodate half-wave dipoles for 7 MHz and below. If this is the case, some folding of the dipole will be necessary. The final shape of the antenna will depend on the dimensions and configuration of the attic. Remember that the center of the dipole carries the most current and therefore does most of the radiating. This part should be as high and unfolded as possible. Because

the dipole ends radiate less energy than the center, their orientation is not as important. They do carry the maximum voltage, nevertheless, so care should be taken to position the ends far enough from other conductors to avoid arcing.

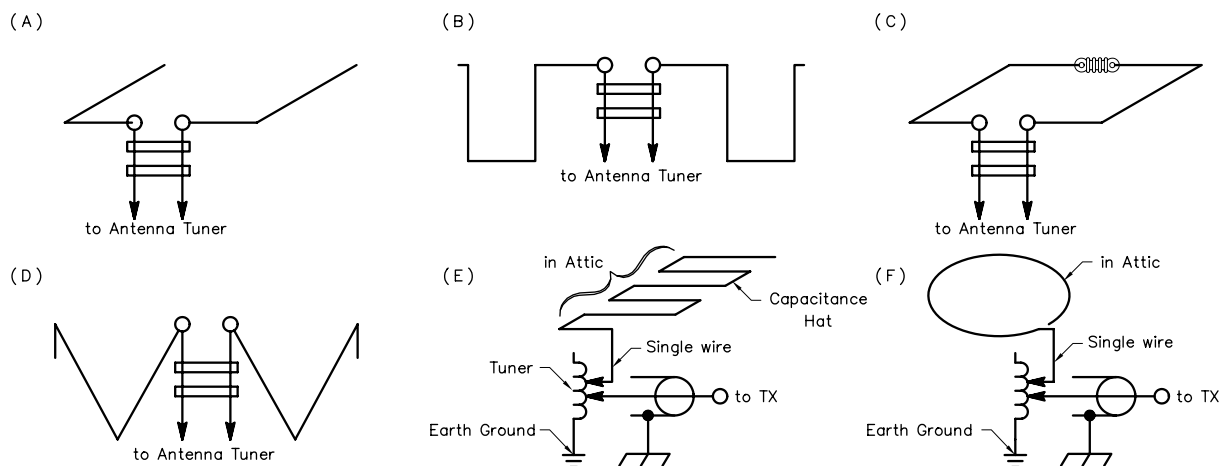
The dipole may end up being L-shaped, Z-shaped, U-shaped or some indescribable corkscrew shape, depending on what space is available, but reasonable performance can often be had even with such a nonlinear arrangement. **Fig 8** shows some possible configurations. Multiband operation is possible with the use of open-wire feeders and an antenna tuner.

One alternative not shown here is the aluminum-foil dipole, which was conceived by Rudy Stork, KA5FSB. He suggests mounting the dipole behind wallpaper or in the attic, with portability, ease of construction and adjustment, and economy in design among its desirable features. This antenna should also display reasonably good bandwidth resulting from the large area of its conductor material. If coaxial feed is used, some pruning of an attic antenna to establish minimum SWR at the band center will be required. Tuning the antenna outdoors and then installing it inside is usually not feasible since the behavior of the antenna will not be the same when placed in the attic. Resonance will be affected somewhat if the antenna is bent.

Even if the antenna is placed in a straight line, parasitic conductors and dielectric loading by nearby wood structures can affect the impedance. Trap and loaded dipoles are shorter than the full-sized versions, but are comparable performers. Trap dipoles are discussed in [Chapter 7](#); loaded dipoles in [Chapter 6](#).

### Dipole Orientation

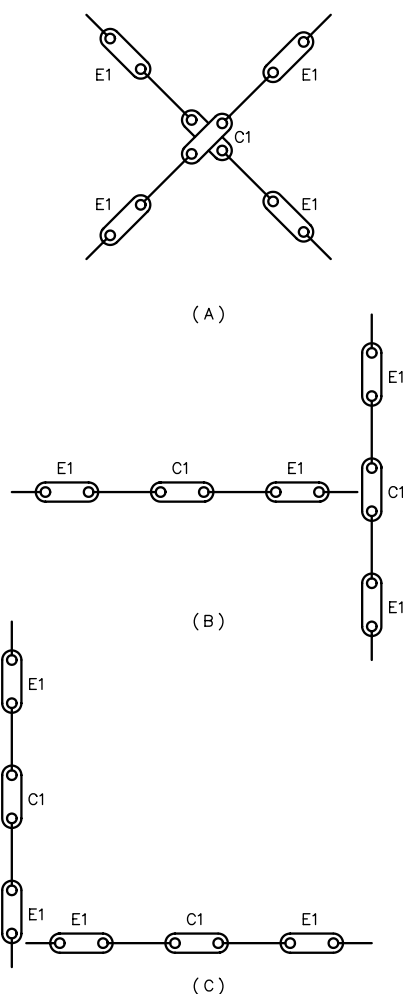
Theoretically a vertical dipole is most effective at low radiation angles, but practical experience shows that the horizontal dipole is usually a better indoor antenna. A high horizontal dipole does exhibit directional effects at low



**Fig 8—Various configurations for small indoor antennas. See text for discussion.**

radiation angles, but you will not be likely to see much, if any, directivity with an attic-mounted dipole. Some operators place two dipoles at right angles to each other with provisions at the operating position for switching between the two. Their reasoning is the radiation patterns will inevitably be distorted in an unpredictable manner by nearby parasitic conductors. There will be little coupling between the dipoles if they are oriented at right angles to each other as shown in **Figs 9A** and **9B**. There will be some coupling with the arrangement shown in **Fig 9C**, but even this orientation is preferable to a single dipole.

With two antennas mounted 90° apart, you may find that one dipole is consistently better in nearly all directions, in which case you will want to remove the inferior dipole, perhaps placing it someplace else. In this manner the best spots in the house or attic can be determined experimentally.



**Fig 9**—Ways to orient a pair of perpendicular dipoles. The orientation at **A** and **B** will result in no mutual coupling between the two dipoles, but there will be some coupling in the configuration shown at **C**. End (**E1**) and center (**C1**) insulators are shown.

## Parasitic Conductors

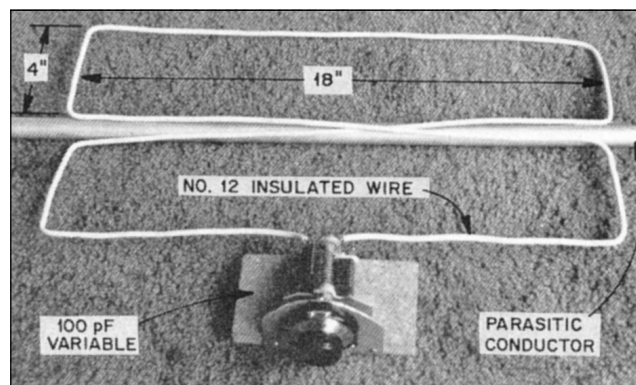
Inevitably, any conductor in your house near a quarter wave in length or longer at the operating frequency will be parasitically coupled to your antenna. The word parasitic is particularly appropriate in this case because these conductors usually introduce losses and leave less energy for radiation into space. Unlike the parasitic elements in a beam antenna conductors such as house wiring and plumbing are usually connected to lossy objects such as earth, electrical appliances, masonry or other objects that dissipate energy. Even where this energy is reradiated, it is not likely to be in the right phase in the desired direction; it is, in fact, likely to be a source of RFI.

There are, however, some things that can be done about parasitic conductors. The most obvious is to reroute them at right angles to the antenna or close to the ground, or even underground-procedures that are usually not feasible in a finished home. Where these conductors cannot be rerouted, other measures can be taken. Electrical wiring can be broken up with RF chokes to prevent the flow of radio-frequency currents while permitting 60-Hz current (or audio, in the case of telephone wires) to flow unimpeded. A typical RF choke for a power line can be 100 turns of #10 insulated wire close wound on a length of 1-inch diameter plastic pipe. Of course one choke will be needed for each conductor. A three-wire line calls for three chokes. The chokes can be simplified by winding them bifilar or trifilar on a single coil form.

## THE RESONANT BREAKER

Obviously, RF chokes cannot be used on conductors such as metal conduit or water pipes. But it is still possible, surprising as it may seem, to obstruct RF currents on such conductors without breaking the metal. The resonant breaker was first described by Fred Brown, W6HPH, in Oct 1979 *QST*.

**Fig 10** shows a method of accomplishing this. A figure-



**Fig 10**—A “resonant breaker” such as shown here can be used to obstruct radio-frequency currents in a conductor without the need to break the conductor physically. A vernier dial is recommended for use with the variable capacitor because tuning is quite sharp. The 100-pF capacitor is in series with the loop. This resonant breaker tunes from 14 through 29.7 MHz. Larger models may be constructed for the lower frequency bands.

eight loop is inductively coupled to the parasitic conductor and is resonated to the desired frequency with a variable capacitor. The result is a very high impedance induced in series with the pipe, conduit or wire. This impedance will block the flow of radio-frequency currents. The figure-eight coil can be thought of as two turns of an air-core toroid and since the parasitic conductor threads through the hole of this core, there will be tight coupling between the two. Inasmuch as the figure-eight coil is parallel resonated, transformer action will reflect a high impedance in series with the linear conductor.

Before you bother with a “resonant breaker” of this type, be sure that there is a significant amount of RF current flowing in the parasitic conductor, and that you will therefore benefit from installing one. The relative magnitude of this current can be determined with an RF current probe of the type described in [Chapter 27](#). According to the rule of thumb regarding parasitic conductor current, if it measures less than  $\frac{1}{10}$  of that measured near the center of the dipole, the parasitic current is generally not large enough to be of concern.

The current probe is also needed for resonating the breaker after it is installed. Normally, the resonant breaker will be placed on the parasitic conductor near the point of

maximum current. When it is tuned through resonance, there will be a sharp dip in RF current, as indicated by the current probe. Of course, the resonant breaker will be effective only on one band. You will need one for each band where there is significant current indicated by the probe.

### Power-Handling Capability

So far, our discussion has been limited to the indoor antenna as a receiving antenna, except for the current measurements, where it is necessary to supply a small amount of power to the antenna. These measurements will not indicate the full power-handling capability of the antenna. Any tendency to flash over must be determined by running full power or, preferably, somewhat more than the peak power you intend to use in regular operation. The antenna should be carefully checked for arcing or RF heating before you do any operating. Bear in mind that attics are indeed vulnerable to fire hazards. A potential of several hundred volts exists at the ends of a dipole fed by the typical Amateur Radio transmitter. If a power amplifier is used, there could be a few thousand volts at the ends of the dipole. Keep your antenna elements well away from other objects. Safety first!

## Construction Details and Practical Considerations

Ultimately the success of an antenna project depends on the details of how the antenna is fabricated. A great deal of construction information is given in other chapters of this book. For example the construction of HF Yagis is discussed in [Chapter 11](#), Quad arrays in [Chapter 12](#), VHF antennas in [Chapter 18](#) and in [Chapter 20](#) there is an excellent discussion of antenna materials, particularly wire and tubing for elements. Here is still more helpful antenna construction information.

### END EFFECT

If the standard expression  $\lambda/2 \approx 491.8/f(\text{MHz})$  is used for the length of a  $\lambda/2$  wire antenna, the antenna will resonate at a somewhat lower frequency than is desired. The reason is that in addition to the effect of the conductor diameter and ground effects ([Chapter 3](#)) an additional “loading” effect is caused by the insulators used at the ends of the wires to support the antenna. The insulators and the wire loops that tie the insulators to the antenna add a small amount of capacitance to the system. This capacitance helps to tune the antenna to a slightly lower frequency, in much the same way that additional capacitance in any tuned circuit lowers the resonant frequency. In an antenna this is called end effect. The current at the ends of the antenna does not quite reach zero because of the end effect, as there is some current flowing into the end capacitance. Note that the computations used to create Figs 2 through 7 in [Chapter 2](#) did not take into account any end effect.

End effect increases with frequency and varies slightly with different installations. However, at frequencies up to

30 MHz (the frequency range over which wire antennas are most commonly used), experience shows that the length of a practical  $\lambda/2$  antenna, including the effect of diameter and end effect, is on the order of 5% less than the length of a half wave in space. As an average, then, the physical length of a resonant  $\lambda/2$  wire antenna can be found from:

$$\lambda = \frac{491.8 \times 0.95}{f \text{ (MHz)}} \approx \frac{468}{f \text{ (MHz)}} \quad (\text{Eq 1})$$

Eq 1 is reasonably accurate for finding the physical length of a  $\lambda/2$  antenna for a given frequency, but does not apply to antennas longer than a half wave in length. In the

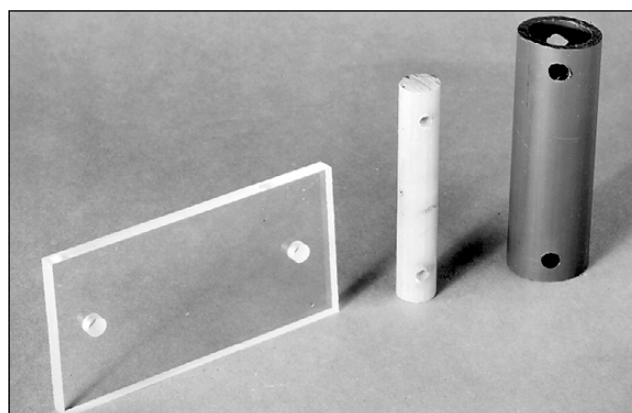


Fig 11—Some ideas for homemade antenna insulators.

practical case, if the antenna length must be adjusted to exact frequency (not all antenna systems require it) the length should be “pruned” to resonance. Note that the use of plastic-insulated wire will typically lower the resonant frequency of a halfwave dipole about 3%.

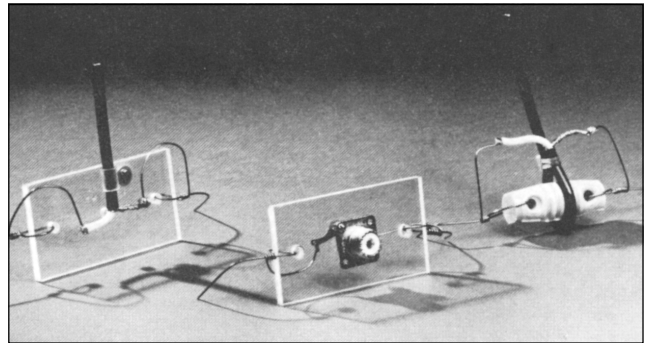
### INSULATORS

Wire antennas must be insulated at the ends. Commercially available insulators are made from ceramic, glass or plastic. Insulators are available from many Amateur

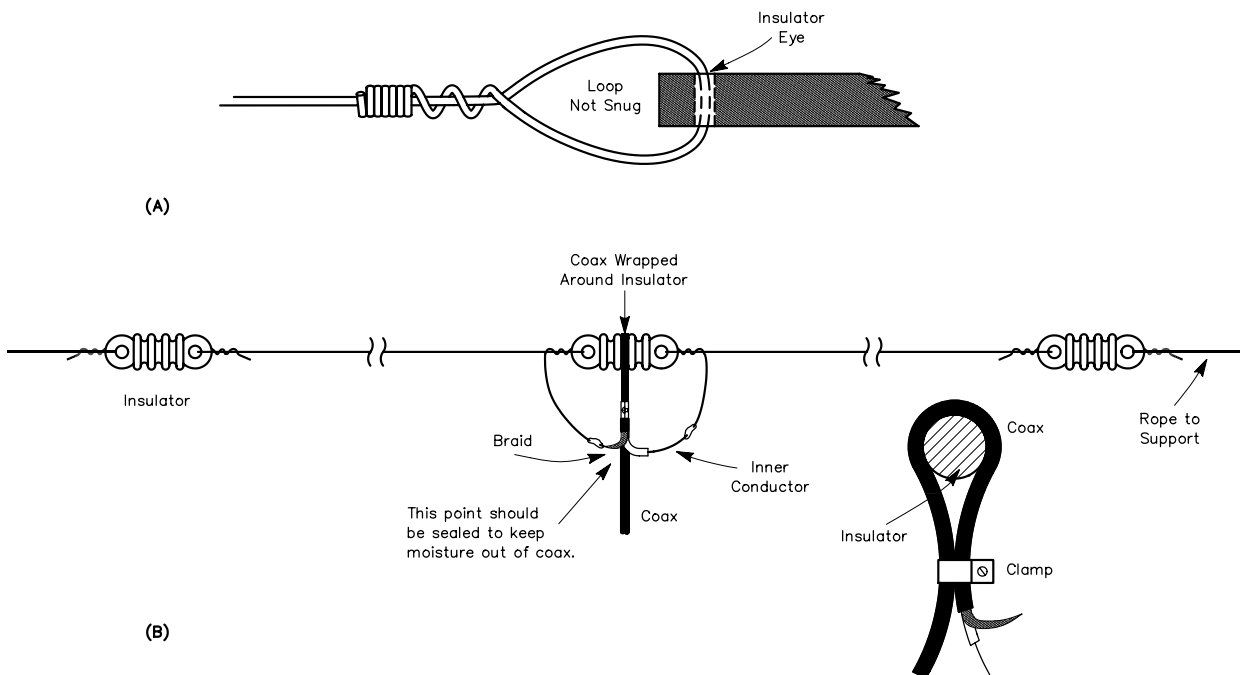
Radio dealers. Radio Shack and local hardware stores are other possible sources. Acceptable homemade insulators may be fashioned from a variety of material including (but not limited to) acrylic sheet or rod, PVC tubing, wood, fiberglass rod or even stiff plastic from a discarded container. **Fig 11** shows some homemade insulators. Ceramic or glass insulators will usually outlast the wire, so they are highly recommended for a safe, reliable, permanent installation. Other materials may tear under stress or break down in the presence of sunlight. Many types of plastic do not weather well.

## Installing Transmission Lines

Many wire antennas require an insulator at the feed point. Although there are many ways to connect the feed line, there are a few things to keep in mind. If you feed your antenna with coaxial cable, you have two choices. You can install an SO-239 connector on the center insulator, as shown by the center example in **Fig 12**, and use a PL-259 on the end of your coax, or you can separate the center conductor from the braid and connect the feed line directly to the antenna wire as shown in the other two examples in Fig 12 and the example in **Fig 13**. Although it costs less to connect direct, the use of connectors offers several advantages. Coaxial cable braid soaks up water like a sponge. If you do not adequately seal the antenna end of the feed line, water will find its way into the braid. Water in the feed line will

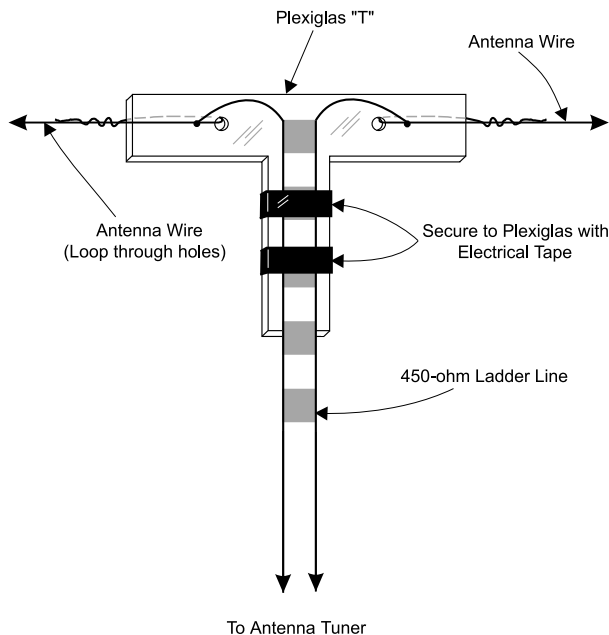


**Fig 12—Some homemade dipole center insulators. The one in the center includes a built-in SO-239 connector. Others are designed for direct connection to the feed line.**

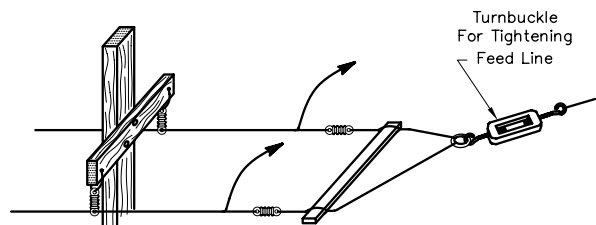


**Fig 13—Details of dipole antenna construction. At A, the end insulator connection is shown. At B, the completed antenna is shown. A balun (not shown) is often used at the feed point, since this is a balanced antenna.**





**Fig 14—A piece of cut Plexiglas can be used as a center insulator and to support a ladder-line feeder. The Plexiglas acts to reduce the flexing of the wires where they connect to the antenna. Use thick Plexiglas in areas subject to high winds.**



**Fig 15—A support for open-wire line. The support at the antenna end of the line must be sufficiently rigid to stand the tension of the line.**

lead to contamination, rendering the coax useless long before its normal lifetime is up.

It is not uncommon for water to drip from the end of the coax inside the shack after a year or so of service if the antenna connection is not properly waterproofed. Use of a PL-259/SO-239 combination (or connector of your choice) makes the task of waterproofing connections much easier. Another advantage to using the PL-259/SO-239 combination is that feed-line replacement is much easier, should that become necessary.

Whether you use coaxial cable, ladder line, or twin lead to feed your antenna, an often overlooked consideration is the mechanical strength of the connection. Wire antennas and feed lines tend to move a lot in the breeze, and unless the feed line is attached securely, the connection will weaken with time. The resulting failure can range from a frustrating intermittent

electrical connection to a complete separation of feed line and antenna. Fig 13 and Fig 14 illustrate different ways of attaching either coax or ladder line to the antenna securely.

When open-wire feed line is used, the conductors of the line should be anchored to the insulator by threading them through the eyes of the insulator two or three times, and twisting the wire back on itself before soldering. A slack tie wire should then be used between the feeder conductor and the antenna, as shown in Fig 14. (The tie wires may be extensions of the line conductors themselves.) When window-type line is suspended from an antenna in a manner such as that shown in Fig 14, the line should be twisted—at several twists per foot—to prevent stress hardening of the wire because of constant flexing in the wind.

When using plastic-insulated open-wire line, the tendency of the line to twist and short out close to the antenna can be counteracted by making the center insulator of the antenna longer than the spacing of the line, as shown in Fig 14. In severe wind areas, it may be necessary to use 1/4-inch thick Plexiglas for the center insulator rather than thinner material.

## RUNNING THE FEED LINE FROM THE ANTENNA TO THE STATION

Chapter 24 contains some general guidelines for installing feed lines. More detailed information is contained in this section. Whenever possible, the transmission line should be lead away from the antenna at a 90° angle to minimize coupling from the antenna to the transmission line. This coupling can cause unequal currents on the transmission line, which will then radiate and it can detune the antenna.

Except for the portion of the line in close proximity to the antenna, coaxial cable requires no particular care in running from the antenna to the station entrance, other than protection from mechanical damage. If the antenna is not supported at the center, the line should be fastened to a post more than head high located under the center of the antenna, allowing enough slack between the post and the antenna to take care of any movement of the antenna in the wind. If the antenna feed point is supported by a tower or mast, the cable can be taped to the mast at intervals or to one leg of the tower.

Coaxial cable rated for direct burial can be buried a few inches in the ground to make the run from the antenna to the station. A deep slit can be cut by pushing a square-end spade full depth into the ground and moving the handle back and forth to widen the slit before removing the spade. After the cable has been pushed into the slit with a piece of 1-inch board 3 or 4 inches wide, the slit can be tamped closed.

Solid ribbon or the newer “window” types of line should be kept reasonably well spaced from other conductors running parallel to it for more than a few feet. The “rule of thumb” is to space open-wire line away from other conductors by at least twice the spacing between the wires in the line. TV-type standoff insulators with strap clamp mountings can be used for running this type of line down a mast or tower leg. Similar insulators of the screw-in type can be used in supporting the line on wooden poles for a long run.

Open-wire lines with bare conductors require frequent supports to keep the lines from twisting and shorting out, as well as to relieve the strain. One method of supporting a long horizontal run of heavy open-wire line is shown in Fig 15. The line must be anchored securely at a point under the feed point of the antenna. Window-type line can be supported similarly with wire links fastened to the insulators.

To keep the line clear of pedestrians and vehicles, it is usually desirable to anchor the feed line at the eaves or rafter line of the station building (see Fig 16), and then drop it vertically to the point of entrance. The points of anchorage and entrance should be chosen to permit the vertical drop without crossing windows.

If the station is located in a room on the ground floor, one way of bringing coax transmission line into the house is to go through the outside wall below floor level, feed it through the basement or crawl space, and then up to the station through a hole in the floor. When making the entrance hole in the side of the building, suitable measurements should be made in advance to be sure the hole will go through the sill 2 or 3 inches above the foundation line (and between joists if the bore is parallel to the joists). The line should be allowed to sag below the entrance hole level outside the building to allow rain water to drip off.

Open-wire line can be fed in a similar manner, although it will require a separate hole for each conductor. Each hole should be insulated with a length of polystyrene or Lucite tubing. If available, ceramic tubes salvaged from old-

fashioned “knob and tube” electrical installations, work very well for this purpose. Drill the holes with a slight downward slant toward the outside of the building to prevent rain seepage. With window ladder line, it will be necessary to remove a few of the spreader insulators, cut the line before passing through the holes (allowing enough length to reach the inside), and splice the remainder on the inside.

If the station is located above ground level, or if there is other objection to the procedure described above, entrance can be made at a window, using the arrangement shown in Fig 17. An Amphenol type 83-1F (UG-363) connector can be used as shown in Fig 18; ceramic feedthrough insulators

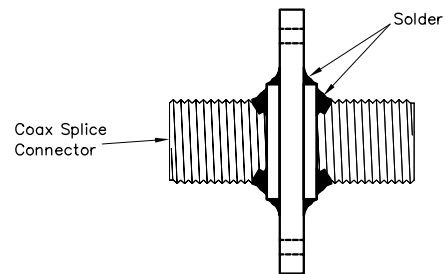


Fig 18—Feedthrough connector for coax line. An Amphenol 83-1J (PL-258) connector, the type used to splice sections of coax line together, is soldered into a hole cut in a brass mounting flange. An Amphenol bulkhead adapter 83-1F may be used instead.

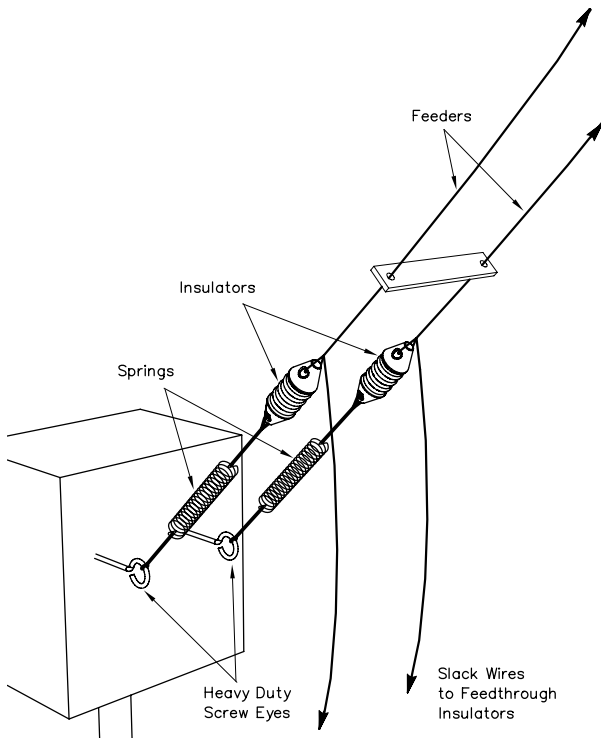


Fig 16—Anchoring open-wire line at the station end. The springs are especially desirable if the line is not supported between the antenna and the anchoring point.

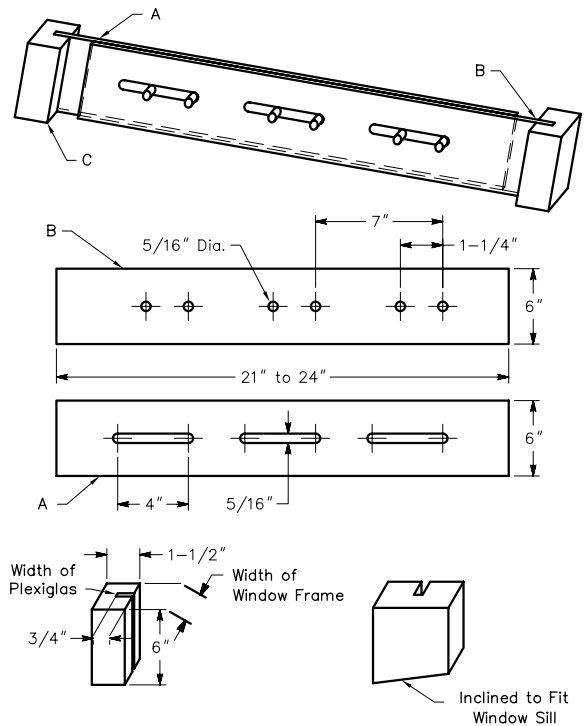
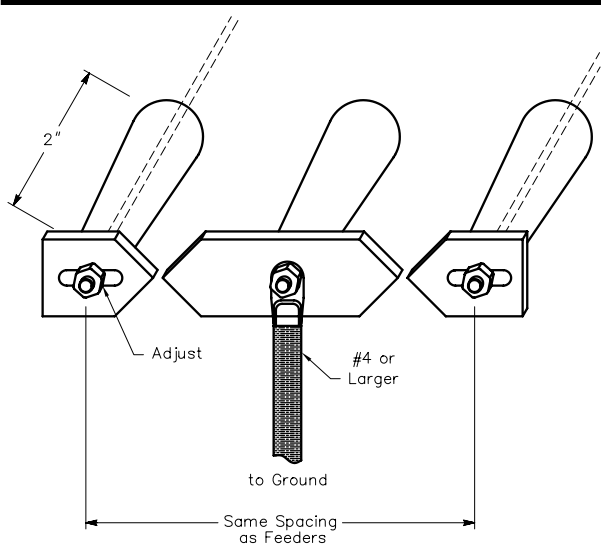
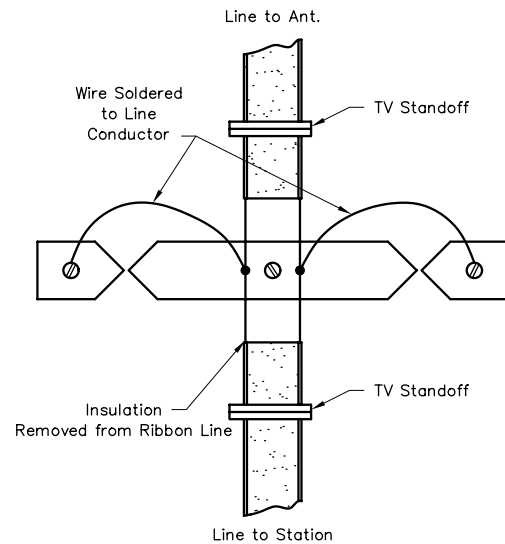


Fig 17—An adjustable window lead-in panel made up of two sheets of Lucite or Plexiglas. A feedthrough connector for coax line can be made as shown in Fig 18. Ceramic feedthrough insulators are suitable for open-wire line (W1RVE).



**Fig 19—A simple lightning arrester for open-wire line made from three standoff or feedthrough insulators and sections of  $\frac{1}{8} \times \frac{1}{2}$ -inch brass or copper strap. It should be installed in the line at the point where the line enters the station. The heavy ground lead should be as short and as direct as possible. The gap setting should be adjusted to the minimum width that will prohibit arcing when the transmitter is operated.**



**Fig 20—The lightning arrester of Fig 19 may be used with 300- $\Omega$  ribbon line in the manner shown here. The TV standoffs support the line an inch or so away from the grounded center member of the arrester.**

can be used for open-wire line. Ribbon line can be run through clearance holes in the panel, and secured by a winding of tape on either side of the panel, or by cutting the retaining rings and insulators from a pair of TV standoff insulators, and clamping one on each side of the panel.

### LIGHTNING PROTECTION

Two or three types of lightning arresters for coaxial cable are available on the market. If the antenna feed point is at the top of a well-grounded tower, the arrester can be fastened securely to the top of the tower for grounding purposes. A short length of cable, terminated in a coaxial plug, is then run from the antenna feed point to one receptacle of the arrester, while the transmission line is run from the other arrester receptacle to the station. Such arresters may also be placed at the entrance point to the station, if a suitable ground connection is available at that point (or arresters may be placed at both points for added insurance).

The construction of a homemade arrester for open-wire line is shown in **Fig 19**. This type of arrester can be adapted to ribbon line an inch or so away from the center member of the arrester, as shown in **Fig 20**. Sufficient insulation should be removed from the line where it crosses the arrester to permit soldering the arrester connecting leads.

### Lightning Grounds

Lightning-ground connecting leads should be of conductor size equivalent to at least #10 wire. The #8 aluminum wire used for TV-antenna grounds is satisfactory. Copper braid  $\frac{3}{4}$  inch wide (Belden 8662-10) is also suitable. The conductor should run in a straight line to the grounding point. The ground connection may be made to a water pipe system (if the pipe is not plastic), the grounded metal frame of a building, or to one or more  $\frac{5}{8}$ -inch ground rods driven to a depth of at least 8 feet. More detailed information on lightning protection is contained in [Chapter 1](#).

# Chapter 5

# Loop Antennas

A loop antenna is a closed-circuit antenna—that is, one in which a conductor is formed into one or more turns so its two ends are close together. Loops can be divided into two general classes, those in which both the total conductor length and the maximum linear dimension of a turn are very small compared with the wavelength, and those in which both the conductor length and the loop dimensions begin to be comparable with the wavelength.

A “small” loop can be considered to be simply a rather large coil, and the current distribution in such a loop is the same as in a coil. That is, the current has the same phase and the same amplitude in every part of the loop. To meet this condition, the total length of conductor in the loop must not exceed about  $0.1 \lambda$ . Small loops are discussed later in this chapter, and further in [Chapter 14](#).

A “large” loop is one in which the current is not the same either in amplitude or phase in every part of the loop. This change in current distribution gives rise to entirely different properties compared with a small loop.

## Half-Wave Loops

The smallest size of “large” loop generally used is one having a conductor length of  $\frac{1}{2} \lambda$ . The conductor is usually formed into a square, as shown in **Fig 1**, making each side  $\frac{1}{8} \lambda$  long. When fed at the center of one side, the current flows in a closed loop as shown in Fig 1A. The current distribution is approximately the same as on a  $\frac{1}{2}$ - $\lambda$  wire, and so is maximum at the center of the side opposite the terminals X-Y, and minimum at the terminals themselves. This current distribution causes the field strength to be maximum in the plane of the loop and in the direction looking from the low-current side to the high-current side. If the side opposite the terminals is opened at the center as shown in Fig 1B (strictly speaking, it is then no longer a loop because it is no longer a closed circuit), the direction of current flow remains unchanged but the maximum current flow occurs at the terminals. This reverses the direction of maximum radiation.

The radiation resistance at a current antinode (which is also the resistance at X-Y in Fig 1B) is on the order of  $50 \Omega$ . The impedance at the terminals in Fig 1A is a few thousand ohms. This can be reduced by using two identical

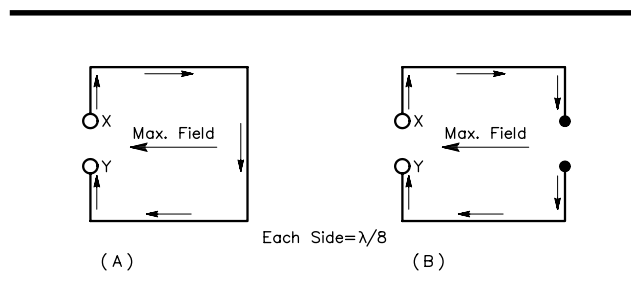
loops side by side with a few inches spacing between them and applying power between terminal X on one loop and terminal Y on the other.

Unlike a  $\frac{1}{2}$ - $\lambda$  dipole or a small loop, there is no direction in which the radiation from a loop of the type shown in Fig 1 is zero. There is appreciable radiation in the direction perpendicular to the plane of the loop, as well as to the “rear”—the opposite direction to the arrows shown. The front-to-back (F/B) ratio is approximately 4 to 6 dB. The small size and the shape of the directive pattern result in a loss of about 1 dB when the field strength in the optimum direction from such a loop is compared with the field from a  $\frac{1}{2}$ - $\lambda$  dipole in its optimum direction.

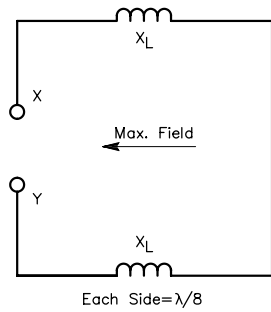
The ratio of the forward radiation to the backward radiation can be increased, and the field strength likewise increased at the same time to give a gain of about 1 dB over a dipole, by using inductive reactances to “load” the sides joining the front and back of the loop. This is shown in **Fig 2**. The reactances, which should have a value of approximately  $360 \Omega$ , decrease the current in the sides in which they are inserted and increase it in the side having terminals. This increases the directivity and thus increases the efficiency of the loop as a radiator. Lossy coils can reduce this advantage greatly.

## One-Wavelength Loops

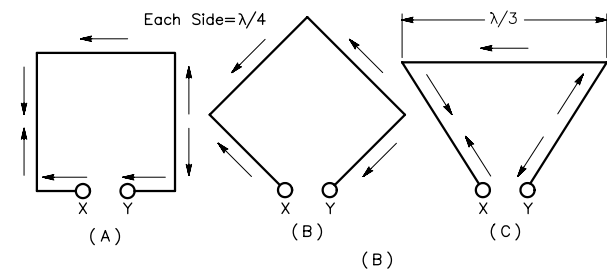
Loops in which the conductor length is  $1 \lambda$  have



**Fig 1—Half-wave loops, consisting of a single turn having a total length of  $\frac{1}{2} \lambda$ .**



**Fig 2—Inductive loading in the sides of a  $\frac{1}{2}\lambda$  loop to increase the directivity and gain. Maximum radiation or response is in the plane of the loop, in the direction shown by the arrow.**



**Fig 3—At A and B, loops having sides  $\frac{1}{4}\lambda$  long, and at C having sides  $\frac{1}{3}\lambda$  long (total conductor length  $1\lambda$ ). The polarization depends on the orientation of the loop and on the position of the feed point (terminals X-Y) around the perimeter of the loop.**

different characteristics than  $\frac{1}{2}\lambda$  loops. Three forms of  $1\lambda$  loops are shown in Fig 3. At A and B the sides of the squares are equal to  $\frac{1}{4}\lambda$ , the difference being in the point at which the terminals are inserted. At C the sides of the triangle are equal to  $\frac{1}{3}\lambda$ . The relative direction of current flow is as

shown in the drawings. This direction reverses halfway around the perimeter of the loop, as such reversals always occur at the junction of each  $\frac{1}{2}\lambda$  section of wire.

The directional characteristics of loops of this type are opposite in sense to those of a small loop. That is, the radiation is maximum perpendicular to the plane of the loop and is minimum in either direction in the plane containing the loop. If the three loops shown in Fig 3 are mounted in a vertical plane with the terminals at the bottom, the radiation is horizontally polarized. When the terminals are moved to the center of one vertical side in Fig 3A, or to a side corner in B, the radiation is vertically polarized. If the terminals are moved to a side corner in C, the polarization will be diagonal, containing both vertical and horizontal components.

In contrast to straight-wire antennas, the electrical length of the circumference of a  $1\lambda$  loop is shorter than the actual length. For a loop made of bare #18 wire and operating at a frequency of 14 MHz, where the ratio of conductor length to wire diameter is large, the loop will be close to resonance when

$$\text{Length}_{\text{feet}} = \frac{1032}{f_{\text{MHz}}}$$

The radiation resistance of a resonant  $1\lambda$  loop is approximately  $120\ \Omega$ , under these conditions. Since the loop dimensions are larger than those of a  $\frac{1}{2}\lambda$  dipole, the radiation efficiency is high.

In the direction of maximum radiation (that is, broadside to the plane of the loop, regardless of the point at which it is fed) the  $1\lambda$  loop will show a small gain over a  $\frac{1}{2}\lambda$  dipole. Theoretically, this gain is about 1 dB, and measurements have confirmed that it is of this order.

The  $1\lambda$  loop is more frequently used as an element of a directive antenna array (the quad and delta-loop antennas described in Chapter 12) than singly, although there is no reason why it cannot be used alone. In the quad and delta loop, it is nearly always driven so that the polarization is horizontal.

## Small Loop Antennas

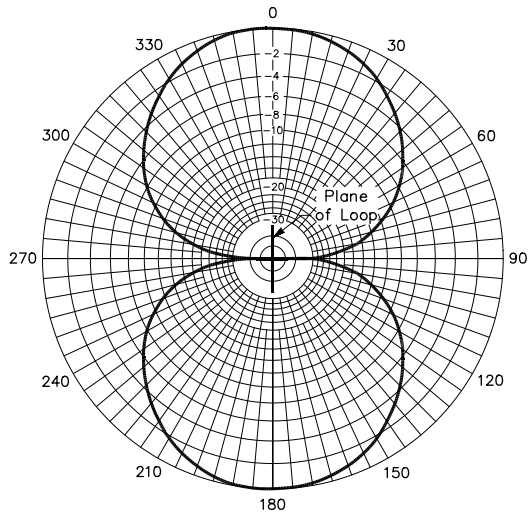
The electrically small loop antenna has existed in various forms for many years. Probably the most familiar form of this antenna is the ferrite *loopstick* found in portable AM broadcast-band receivers. Amateur applications of the small loop include direction finding, low-noise directional receiving antennas for 1.8 and 3.5 MHz, and small transmitting antennas. Because the design of transmitting and receiving loops requires some different considerations, the two situations are examined separately in this section. This information was written by Domenic M. Mallozzi, N1DM.

### The Basic Loop

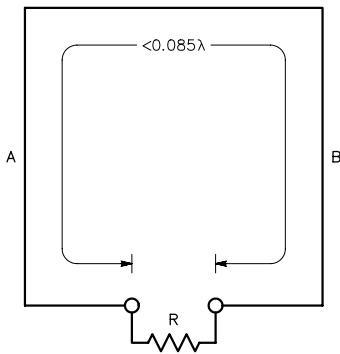
What is and what is not a small loop antenna? By

definition, the loop is considered to be electrically small when its total conductor length is less than  $0.1\lambda$ —0.085 is the number used in this section. This size is based on the fact that the current around the perimeter of the loop must be in phase. When the winding conductor is more than about  $0.085\lambda$  long, this is no longer true. This constraint results in a very predictable figure-eight radiation pattern, shown in Fig 4.

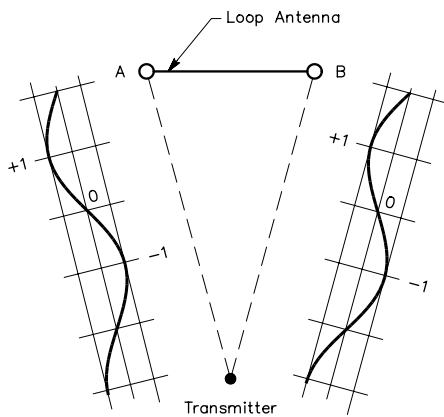
The simplest loop is a 1-turn untuned loop with a load connected to a pair of terminals located in the center of one of the sides, as shown in Fig 5. How its pattern is developed is easily pictured if we look at some “snapshots” of the antenna relative to a signal source. Fig 6 represents a loop from above, and shows the instantaneous radiated voltage



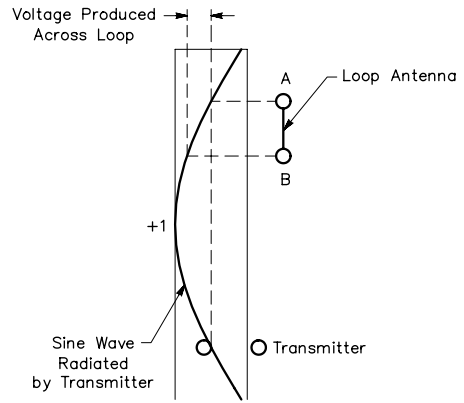
**Fig 4—Calculated small loop antenna radiation pattern.**



**Fig 5—Simple untuned small loop antenna.**



**Fig 6—Example of orientation of loop antenna that does not respond to a signal source (null in pattern).**



**Fig 7—Example of orientation of loop antenna for maximum response.**

wave. Note that points A and B of the loop are receiving the same instantaneous voltage. This means that no current will flow through the loop, because there is no current flow between points of equal potential. A similar analysis of **Fig 7**, with the loop turned 90° from the position represented in Fig 6, shows that this position of the loop provides maximum response. Of course, the voltage derived from the passing wave is small because of the small physical size of the loop. Fig 4 shows the ideal radiation pattern for a small loop.

The voltage across the loop terminals is given by

$$V = \frac{2\pi A N E \cos \theta}{\lambda} \quad (\text{Eq 1})$$

where

V = voltage across the loop terminals

A = area of loop in square meters

N = number of turns in the loop

E = RF field strength in volts per meter

$\theta$  = angle between the plane of the loop and the signal source (transmitting station)

$\lambda$  = wavelength of operation in meters

This equation comes from a term called *effective height*. The effective height refers to the height (length) of a vertical piece of wire above ground that would deliver the same voltage to the receiver. The equation for effective height is

$$h = \frac{2\pi N A}{\lambda} \quad (\text{Eq 2})$$

where h is in meters and the other terms are as for Eq 1.

A few minutes with a calculator will show that, with the constraints previously stated, the loop antenna will have a very small effective height. This means it will deliver a relatively small voltage to the receiver, with even a large transmitted signal.

## TUNED LOOPS

We can tune the loop by placing a capacitor across the antenna terminals. This causes a larger voltage to appear

across the loop terminals because of the Q of the parallel resonant circuit that is formed.

The voltage across the loop terminals is now given by

$$V = \frac{2\pi A N E Q \cos\theta}{\lambda} \quad (\text{Eq 3})$$

where Q is the loaded Q of the tuned circuit, and the other terms are as defined above.

Most amateur loops are of the tuned variety. For this reason, all comments that follow are based on tuned-loop antennas, consisting of one or more turns. The tuned-loop antenna has some particular advantages. For example, it puts high selectivity up at the “front” of a receiving system, where it can significantly help factors such as dynamic range. Loaded Q values of 100 or greater are easy to obtain with careful loop construction.

Consider a situation where the inherent selectivity of the loop is helpful. Assume we have a loop with a Q of 100 at 1.805 MHz. We are working a DX station on 1.805 MHz and are suffering strong interference from a local station 10 kHz away. Switching from a dipole to a small loop will reduce the strength of the off-frequency signal by 6 dB (approximately one S unit). This, in effect, increases the dynamic range of the receiver. In fact, if the off-frequency station were further off frequency, the attenuation would be greater.

Another way the loop can help is by using the nulls in its pattern to null out on-frequency (or slightly off-frequency) interference. For example, say we are working a DX station to the north, and just 1 kHz away is another local station engaged in a contact. The local station is to our west. We can simply rotate our loop to put its null to the west, and now the DX station should be readable while the local will be knocked down by 60 or more dB. This obviously is quite a noticeable difference. Loop nulls are very sharp and are generally noticeable only on ground-wave signals (more on this later).

Of course, this method of nulling will be effective only if the interfering station and the station being worked are not in the same direction (or in exact opposite directions) from our location. If the two stations were on the same line from our location, both the station being worked and the undesired station would be nulled out. Luckily the nulls are very sharp, so as long as the stations are at least 10° off axis from each other, the loop null will be usable.

A similar use of the nulling capability is to eliminate local noise interference, such as that from a light dimmer in a neighbor’s house. Just put the null on the offending light dimmer, and the noise should disappear.

Now that we have seen some possible uses of the small loop, let us look at a bit of detail about its design. First, the loop forms an inductor having a very small ratio of winding length to diameter. The equations for finding inductance given in most radio handbooks assume that the inductor coil is longer than its diameter. However, [F. W. Grover](#) of the US National Bureau of Standards has provided equations

for inductors of common cross-sectional shapes and small length-to-diameter ratios. (See the [Bibliography](#) at the end of this chapter.) Grover’s equations are shown in **Table 1**. Their use will yield relatively accurate numbers; results are easily worked out with a scientific calculator or home computer.

The value of a tuning capacitor for a loop is easy to calculate from the standard resonance equations. The only matter to consider before calculating this is the value of distributed capacitance of the loop winding. This capacitance shows up between adjacent turns of the coil because of their slight difference in potential. This causes each turn to appear as a charge plate. As with all other capacitances, the value of the distributed capacitance is based on the physical dimensions of the coil. An exact mathematical analysis of its value is a complex problem. A simple approximation is given by [Medhurst](#) (see [Bibliography](#)) as

$$C = HD \quad (\text{Eq 4})$$

where

C = distributed capacitance in pF

H = a constant related to the length-to-diameter ratio of the coil (**Table 2** gives H values for length-to-diameter ratios used in loop antenna work.)

D = diameter of the winding in cm

---

**Table 1**  
**Inductance Equations for Short Coils**  
**(Loop Antennas)**

Triangle:

$$L(\mu\text{H}) = 0.006N^2s \left[ \ln \left( \frac{1.1547 sN}{(N+1)\ell} \right) + 0.65533 + \frac{0.1348(N+1)\ell}{sN} \right]$$

Square:

$$L(\mu\text{H}) = 0.008N^2s \left[ \ln \left( \frac{1.4142 sN}{(N+1)\ell} \right) + 0.37942 + \frac{0.3333(N+1)\ell}{sN} \right]$$

Hexagon:

$$L(\mu\text{H}) = 0.012N^2s \left[ \ln \left( \frac{2sN}{(N+1)\ell} \right) + 0.65533 + \frac{0.1348(N+1)\ell}{sN} \right]$$

Octagon:

$$L(\mu\text{H}) = 0.016N^2s \left[ \ln \left( \frac{2.613sN}{(N+1)\ell} \right) + 0.75143 + \frac{0.07153(N+1)\ell}{sN} \right]$$

where

N = number of turns

s = side length in cm

ℓ = coil length in cm

Note: In the case of single-turn coils, the diameter of the conductor should be used for ℓ.

---

**Table 2**  
**Values of the Constant H**  
**for Distributed Capacitance**

Length to Diameter Ratio	H
0.10	0.96
0.15	0.79
0.20	0.78
0.25	0.64
0.30	0.60
0.35	0.57
0.40	0.54
0.50	0.50
1.00	0.46

Medhurst's work was with coils of round cross section. For loops of square cross section the distributed capacitance is given by [Bramslev](#) (see [Bibliography](#)) as

$$C = 60S \quad (\text{Eq 5})$$

where

C = the distributed capacitance in pF

S = the length of the side in meters

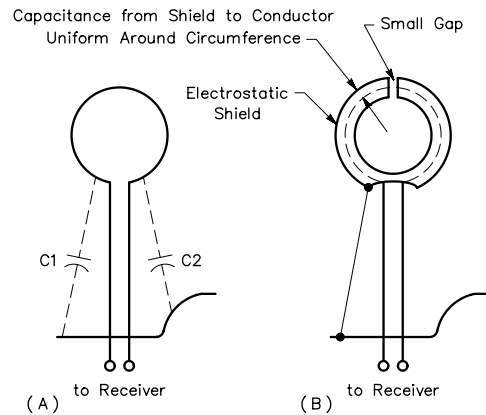
If you convert the length in this equation to centimeters, you will find [Bramslev's](#) equation gives results in the same order of magnitude as [Medhurst's](#) equation.

This distributed capacitance appears as if it were a capacitor across the loop terminals. Therefore, when determining the value of the tuning capacitor, the distributed capacitance must be subtracted from the total capacitance required to resonate the loop. The distributed capacitance also determines the highest frequency at which a particular loop can be used, because it is the minimum capacitance obtainable.

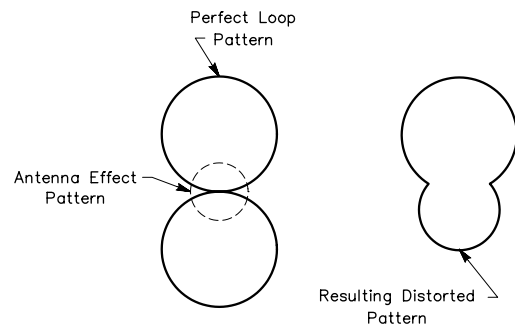
### Electrostatically Shielded Loops

Over the years, many loop antennas have incorporated an electrostatic shield. This shield generally takes the form of a tube around the winding, made of a conductive but nonmagnetic material (such as copper or aluminum). Its purpose is to maintain loop balance with respect to ground, by forcing the capacitance between all portions of the loop and ground to be identical. This is illustrated in [Fig 8](#). It is necessary to maintain electrical loop balance to eliminate what is referred to as the *antenna effect*. When the antenna becomes unbalanced it appears to act partially as a small vertical antenna. This vertical pattern gets superimposed on the ideal figure-eight pattern, distorting the pattern and filling in the nulls. The type of pattern that results is shown in [Fig 9](#).

Adding the shield has the effect of somewhat reducing the pickup of the loop, but this loss is generally offset by the increase in null depth of the loops. Proper balance of the loop antenna requires that the load on the loop also be balanced. This is usually accomplished by use of a balun



**Fig 8—At A, the loop is unbalanced by capacitance to its surroundings. At B, the use of an electrostatic shield overcomes this effect.**



**Fig 9—Distortion in loop pattern resulting from antenna effect.**

transformer or a balanced input preamplifier. One important point regarding the shield is that it cannot form a continuous electrical path around the loop perimeter, or it will appear as a shorted coil turn. Usually the insulated break is located opposite the feed point to maintain symmetry. Another point to be considered is that the shield should be of a much larger diameter than the loop winding, or it will lower the Q of the loop.

Various construction techniques have been used in making shielded loops. [Genaille](#) located his loop winding inside aluminum conduit, while [True](#) constructed an aluminum shield can around his winding. Others have used pieces of Hardline to form a loop, using the outer conductor as a shield. [DeMaw](#) used flexible coax with the shield broken at the center of the loop conductor in a multiturn loop for 1.8 MHz. [Goldman](#) uses another shielding method for broadcast receiver loops. His shield is in the form of a barrel made of hardware cloth, with the loop in its center. (See [Bibliography](#) for above references.) All these methods provide sufficient shielding to maintain the balance. It is possible, as [Nelson](#) shows, to construct an unshielded loop



with good nulls (60 dB or better) by paying great care to symmetry.

### LOOP Q

As previously mentioned, Q is an important consideration in loop performance because it determines both the loop bandwidth and its terminal voltage for a given field strength. The loaded Q of a loop is based on four major factors. These are (1) the intrinsic Q of the loop winding, (2) the effect of the load, (3) the effect of the electrostatic shield, and (4) the Q of the tuning capacitor.

The major factor is the Q of the winding of the loop itself. The ac resistance of the conductor caused by skin effect is the major consideration. The ac resistance for copper conductors may be determined from

$$R = \frac{0.996 \times 10^{-6} \sqrt{f}}{d} \quad (\text{Eq 6})$$

where

- R = resistance in ohms per foot
- f = frequency, Hz
- d = conductor diameter, inches

The Q of the inductor is then easily determined by taking the reactance of the inductor and dividing it by the ac resistance. If you are using a multiturn loop and are a perfectionist, you might also want to include the loss from conductor proximity effect. This effect is described in detail later in this chapter, in the section on transmitting loops.

Improvement in Q can be obtained in some cases by the use of Litz wire (short for *Litzendraht*). Litz wire consists of strands of individual insulated wires that are woven into bundles in such a manner that each conductor occupies each location in the bundle with equal frequency. Litz wire results in improved Q over solid or stranded wire of equivalent size, up to about 3 MHz.

Also, the Q of the tuned circuit of the loop antenna is determined by the Q of the capacitors used to resonate it. In the case of air variables or dipped micas this is not usually a problem. But if variable-capacitance diodes are used to remotely tune the loop, pay particular attention to the manufacturer's specification for Q of the diode at the frequency of operation. The tuning diodes can have a significant effect on circuit Q.

Now we consider the effect of load impedance on loop Q. In the case of a directly coupled loop (as in Fig 5), the load is connected directly across the loop terminals, causing it to be treated as a parallel resistance in a parallel-tuned RLC circuit. Obviously, if the load is of a low value, the Q of the loop will be low. A simple way to correct this is to use a transformer to step up the load impedance that appears across the loop terminals. In fact, if we make this transformer a balun, it also allows us to use our unbalanced receivers with the loop and maintain loop symmetry. Another solution is to use what is referred to as an inductively coupled loop, such as DeMaw's four turn electrostatically shielded loop. A one-turn link is connected to the receiver. This turn is

wound with the four-turn loop. In effect, this builds the transformer into the antenna.

Another solution to the problem of load impedance on loop Q is to use an active preamplifier with a high impedance balanced input and unbalanced output. This method also has the advantage of amplifying the low-level output voltage of the loop to where it can be used with a receiver of even mediocre sensitivity. In fact, the Q of the loop when used with a balanced preamplifier having high input impedance may be so high as to be unusable in certain applications. An example of this situation would occur where a loop is being used to receive a 5 kHz wide AM signal at a frequency where the bandwidth of the loop is only 1.5 kHz. In this case the detected audio might be very distorted. The solution to this is to put a Q-degrading resistor across the loop terminals.

### FERRITE-CORE LOOP ANTENNAS

The ferrite-core loop antenna is a special case of the air-core receiving loops considered up to now. Because of its use in every AM broadcast-band portable radio, the ferrite-core loop is, by quantity, the most popular form of the loop antenna. But broadcast-band reception is far from its only use; it is commonly found in radio direction finding equipment and low frequency receiving systems (below 500 kHz) for time and frequency standard systems. In recent years, design information on these types of antennas has been a bit sparse in the amateur literature, so the next few paragraphs are devoted to providing some details.

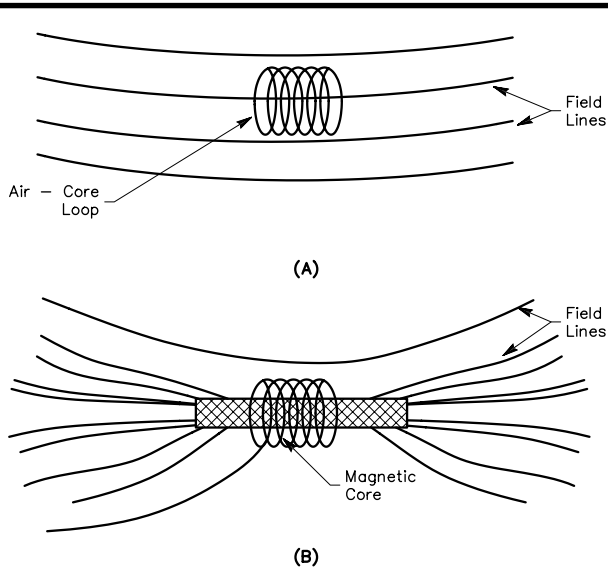
Ferrite loop antennas are characteristically very small compared to the frequency of use. For example, a 3.5-MHz version may be in the range of 15 to 30 cm long and about 1.25 cm in diameter. Earlier in this chapter, effective height was introduced as a measure of loop sensitivity. The effective height of an air-core loop antenna is given by Eq 2.

If an air-core loop is placed in a field, in essence it cuts the lines of flux without disturbing them (Fig 10A). On the other hand, when a ferrite (magnetic) core is placed in the field, the nearby field lines are redirected into the loop (Fig 10B). This is because the reluctance of the ferrite material is less than that of the surrounding air, so the nearby flux lines tend to flow through the loop rather than passing it by. (Reluctance is the magnetic analogy of resistance, while flux is analogous to current.) The reluctance is inversely proportional to the permeability of the rod core,  $\mu_{\text{rod}}$ . (In some texts the rod permeability is referred to as effective permeability,  $\mu_{\text{eff}}$ .) This effect modifies the equation for effective height of a ferrite-core loop to

$$h = \frac{2\pi N A \mu_{\text{rod}}}{\lambda} \quad (\text{Eq 7})$$

where

- h = effective height (length) in meters
- N = number of turns in the loop
- A = area of loop in square meters
- $\mu_{\text{rod}}$  = permeability of the ferrite rod
- $\lambda$  = wavelength of operation in meters



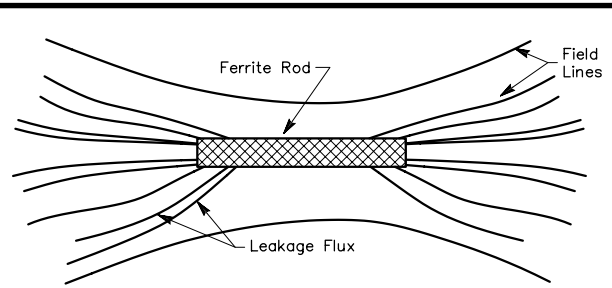
**Fig 10—At A, an air-core loop has no effect on nearby field lines. B illustrates the effect of a ferrite core on nearby field lines. The field is altered by the reluctance of the ferrite material.**

This obviously is a large increase in “collected” signal. If the rod permeability were 90, this would be the same as making the loop area 90 times larger with the same number of turns. For example, a 1.25-cm diameter ferrite-core loop would have an effective height equal to an air-core loop 22.5 cm in diameter (with the same number of turns).

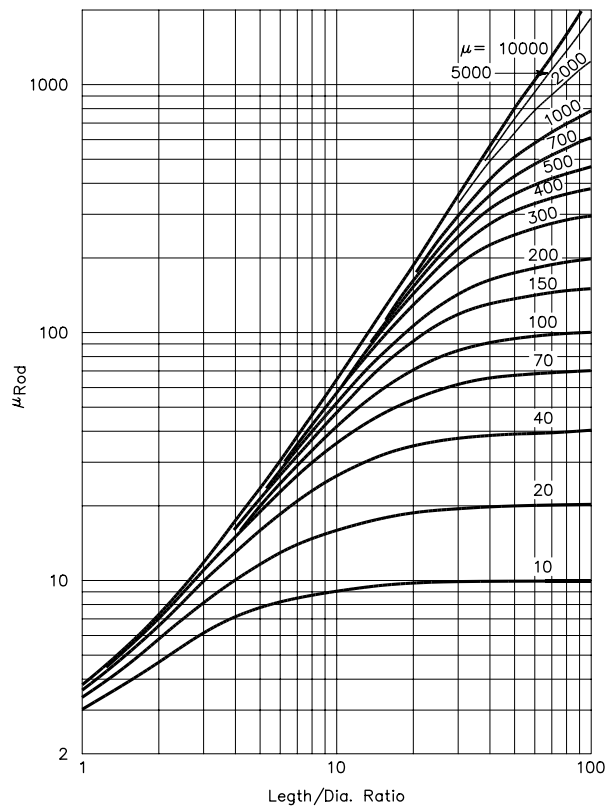
By now you might have noticed we have been very careful to refer to rod permeability. There is a very important reason for this. The permeability that a rod of ferrite exhibits is a combination of the material permeability or  $\mu$ , the shape of the rod, and the dimensions of the rod. In ferrite rods,  $\mu$  is sometimes referred to as initial permeability,  $\mu_i$ , or toroidal permeability,  $\mu_{tor}$ . Because most amateur ferrite loops are in the form of rods, we will discuss only this shape.

The reason that  $\mu_{rod}$  is different from  $\mu$  is a very complex physics problem that is well beyond the scope of this book. For those interested in the details, books by Polydoroff and by Snelling cover this subject in considerable detail. (See Bibliography.) For our purposes a simple explanation will suffice. The rod is in fact not a perfect director of flux, as is illustrated in Fig 11. Note that some lines impinge on the sides of the core and also exit from the sides. These lines therefore would not pass through all the turns of the coil if it were wound from one end of the core to the other. These flux lines are referred to as *leakage flux*, or sometimes as flux leakage.

Leakage flux causes the flux density in the core to be nonuniform along its length. From Fig 11 it can be seen that the flux has a maximum at the geometric center of the length of the core, and decreases as the ends of the core are approached. This causes some noticeable effects. As a short



**Fig 11—Example of magnetic field lines near a practical ferrite rod, showing leakage flux.**



**Fig 12—Rod permeability,  $\mu_{rod}$ , versus material permeability,  $\mu$ , for different rod length-to-diameter ratios.**

coil is placed at different locations along a long core, its inductance will change. The maximum inductance exists when the coil is centered on the rod. The Q of a short coil on a long rod is greatest at the center. On the other hand, if you require a higher Q than this, it is recommended that you spread the coil turns along the whole length of the core, even though this will result in a lower value of inductance. (The inductance can be increased to the original value by adding turns.) Fig 12 gives the relationship of rod permeability to material permeability for a variety of values.

The change in  $\mu$  over the length of the rod results in an

adjustment in the term  $\mu_{rod}$  for its so called “free ends” (those not covered by the winding). This adjustment factor is given by

$$\mu' = \mu_{rod} \sqrt[3]{\frac{a}{b}} \quad (\text{Eq 8})$$

where

- $\mu'$  = the corrected permeability
- $a$  = the length of the core
- $b$  = the length of the coil

This value of  $\mu'$  should be used in place of  $\mu_{rod}$  in Eq 7 to obtain the most accurate value of effective height.

All these variables make the calculation of ferrite loop antenna inductance somewhat less accurate than for the air-core version. The inductance of a ferrite loop is given by

$$L = \frac{4\pi N^2 A \mu_{rod} \times 10^{-4}}{\ell} \quad (\text{Eq 9})$$

where

- $L$  = inductance in  $\mu\text{H}$
- $N$  = number of turns
- $A$  = cross-sectional area of the core in square mm
- $\ell$  = magnetic length of core in mm

Experiments indicate that the winding diameter should be as close to that of the rod diameter as practical in order to maximize both inductance value and  $Q$ . By using all this information, we may determine the voltage at the loop terminals and its signal-to-noise ratio (SNR). The voltage may be determined from

$$V = \frac{2\pi A N \mu' Q E}{\lambda} \quad (\text{Eq 10})$$

where

- $V$  = output voltage across the loop terminals
- $A$  = loop area in square meters
- $N$  = number of turns in the loop winding
- $\mu'$  = corrected rod permeability
- $Q$  = loaded  $Q$  of the loop
- $E$  = RF field strength in volts per meter
- $\lambda$  = wavelength of operation in meters

Lankford's equation for the sensitivity of the loop for a 10 dB SNR is

$$E = \frac{1.09 \times 10^{-10} \lambda \sqrt{f L b}}{A N \mu' \sqrt{Q}} \quad (\text{Eq 11})$$

where

- $f$  = operating frequency in Hz
- $L$  = loop inductance in henrys
- $b$  = receiver bandwidth in Hz

Similarly, Belrose gives the SNR of a tuned loop antenna as

$$\text{SNR} = \frac{66.3 N A \mu_{rod} E}{\sqrt{b}} \sqrt{\frac{Qf}{L}} \quad (\text{Eq 12})$$

From this, if the field strength  $E$ ,  $\mu_{rod}$ ,  $b$ , and  $A$  are fixed, then  $Q$  or  $N$  must increase (or  $L$  decrease) to yield a better SNR. Higher sensitivity can also be obtained (especially at frequencies below 500 kHz) by bunching ferrite cores together to increase the loop area over that which would be possible with a single rod. High sensitivity is important because loop antennas are not the most efficient collectors of signals, but they do offer improvement over other receiving antennas in terms of SNR. For this reason, you should attempt to maximize the SNR when using a small loop receiving antenna. In some cases there may be physical constraints that limit how large you can make a ferrite-core loop.

After working through Eq 11 or 12, you might find you still require some increase in antenna system gain to effectively use your loop. In these cases the addition of a low noise preamplifier may be quite valuable even on the lower frequency bands where they are not commonly used. Chapter 14 contains information on such preamplifiers.

The electrostatic shield discussed earlier with reference to air-core loops can be used effectively with ferrite-core loops. (Construction examples are presented in Chapter 14.) As in the air-core loop, a shield will reduce electrical noise and improve loop balance.

## PROPAGATION EFFECTS ON NULL DEPTH

After building a balanced loop you may find it does not approach the theoretical performance in the null depth. This problem may result from propagation effects. Tilting the loop away from a vertical plane may improve performance under some propagation conditions, to account for the vertical angle of arrival. Basically, the loop performs as described above only when the signal is arriving perpendicular to the axis of rotation of the loop. At incidence angles other than perpendicular, the position and depth of the nulls deteriorate.

The problem can be even further influenced by the fact that if the loop is situated over less than perfectly conductive ground, the wave front will appear to tilt or bend. (This bending is not always detrimental; in the case of Beverage antennas, sites are chosen to take advantage of this effect.)

Another cause of apparent poor performance in the null depth can be from polarization error. If the polarization of the signal is not completely linear, the nulls will not be sharp. In fact, for circularly polarized signals, the loop might appear to have almost no nulls. Propagation effects are discussed further in Chapter 14.

## SITING EFFECTS ON THE LOOP

The location of the loop has an influence on its performance that at times may become quite noticeable. For ideal performance the loop should be located outdoors and clear of any large conductors, such as metallic downspouts and towers. A VLF loop, when mounted this way, will show good sharp nulls spaced  $180^\circ$  apart if the loop is well

balanced. This is because the major propagation mode at VLF is by ground wave. At frequencies in the HF region, a significant portion of the signals are propagated by sky wave, and nulls are often only partial.

Most hams locate their loop antennas near their operating position. If you choose to locate a small loop indoors, its performance may show nulls of less than the expected depth, and some skewing of the pattern. For precision direction finding there may be some errors associated with wiring, plumbing, and other metallic construction members in the building. Also, a strong local signal may be reradiated from the surrounding conductors so that it cannot be nulled with any positioning of the loop. There appears to be no known method of curing this type of problem. All this should not discourage you from locating a loop indoors; this information is presented here only to give you an idea of some pitfalls. Many hams have reported excellent results with indoor mounted loops, in spite of some of the problems.

Locating a receiving loop in the field of a transmitting antenna may cause a large voltage to appear at the receiver antenna terminals. This may be sufficient to destroy sensitive RF amplifier transistors or front-end protection diodes. This can be solved by disconnecting your loop from the receiver during transmit periods. This can obviously be done automatically with a relay that opens when the transmitter is activated.

## LOOP ANTENNA ARRAYS

Arrays of loop antennas, both in combination with each other and with other antenna types, have been used for many years. The arrays are generally used to cure some “deficiency” in the basic loop for a particular application, such as a 180° ambiguity in the null direction, low sensitivity, and so forth.

### A Sensing Element

For direction-finding applications the single loop suffers the problem of having two nulls that are 180° apart. This leads to an ambiguity of 180° when trying to find the direction to a transmitting station from a given location. A sensing element (often called a *sense antenna*) may be added to the loop, causing the overall antenna to have a cardioid pattern and only one null. The sensing element is a small vertical antenna whose height is equal to or greater than the loop effective height. This vertical is physically close to the loop, and when its omnidirectional pattern is adjusted so that its amplitude and phase are equal to one of the loop lobes, the patterns combine to form a cardioid. This antenna can be made quite compact by use of a ferrite loop to form a portable DF antenna for HF direction finding. [Chapter 14](#) contains additional information and construction projects using sensing elements.

### Arrays of Loops

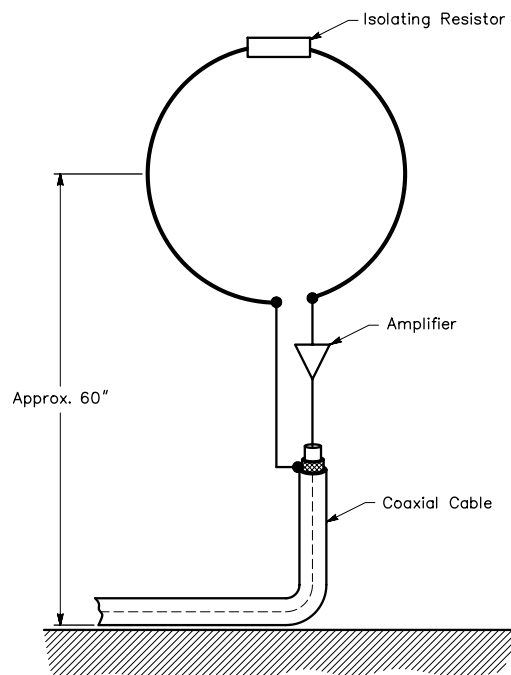
A more advanced array which can develop more diverse patterns consists of two or more loops. Their outputs are

combined through appropriate phasing lines and combiners to form a phased array. Two loops can also be formed into an array which can be rotated without physically turning the loops themselves. This method was developed by Bellini and Tosi in 1907 and performs this apparently contradictory feat by use of a special transformer called a *goniometer*. The goniometer is described in [Chapter 14](#).

## Aperiodic Arrays

The aperiodic loop array is a wide-band antenna. This type of array is useful over at least a decade of frequency, such as 2 to 20 MHz. Unlike most of the loops discussed up to now, the loop elements in an aperiodic array are untuned. Such arrays have been used commercially for many years. One loop used in such an array is shown in **Fig 13**. This loop is quite different from all the loops discussed so far in this chapter because its pattern is not the familiar figure eight. Rather, it is omnidirectional.

The antenna is omnidirectional because it is purposely unbalanced, and also because the isolating resistor causes the antenna to appear as two closely spaced short monopoles. The loop maintains the omnidirectional characteristics over a frequency range of at least four or five to one. These loops, when combined into end-fire or broadside phased arrays, can provide quite impressive performance. A commercially made end-fire array of this type consisting of four loops equally spaced along a 25-meter baseline can provide gains in excess of 5 dBi over a range of 2 to 30 MHz. Over a



**Fig 13**—A single wide-band loop antenna used in an aperiodic array.

considerable portion of this frequency range, the array can maintain F/B ratios of 10 dB. Even though the commercial version is very expensive, an amateur version can be constructed using the information provided by Lambert. One interesting feature of this type of array is that, with the proper combination of hybrids and combiners, the antenna can simultaneously feed two receivers with signals from different directions, as shown in Fig 14. This antenna may be especially interesting to one wanting a directional receiving array for two or more adjacent amateur bands.

### SMALL TRANSMITTING LOOP ANTENNAS

The electrically small transmitting loop antenna involves some different design considerations compared to receiving loops. Unlike receiving loops, the size limitations of the antenna are not as clearly defined. For most purposes, any transmitting loop whose physical circumference is less than  $\frac{1}{4} \lambda$  can be considered “small.” In most cases, as a consequence of their relatively large size (when compared to a receiving loop), transmitting loops have a nonuniform current distribution along their circumference. This leads to some performance changes from a receiving loop.

The transmitting loop is a parallel-tuned circuit with a large inductor acting as the radiator. As with the receiving loop, the calculation of the transmitting loop inductance may be carried out with the equations in Table 1. Avoid equations for long solenoids found in most texts. Other fundamental equations for transmitting loops are given in Table 3.

In the March 1968 *QST*, Lew McCoy, WIICP, introduced the so-called “Army Loop” to radio amateurs. This was an amateur version of a loop designed for portable use in Southeast Asia by Patterson of the US Army and described in 1967. The Army Loop is diagrammed in Fig 15A, showing that this is a parallel tuned circuit fed by

**Table 3**  
**Transmitting Loop Equations**

$$X_L = 2\pi fL \text{ ohms}$$

$$Q = \frac{f}{\Delta f} = \frac{X_L}{2(R_R + R_L)}$$

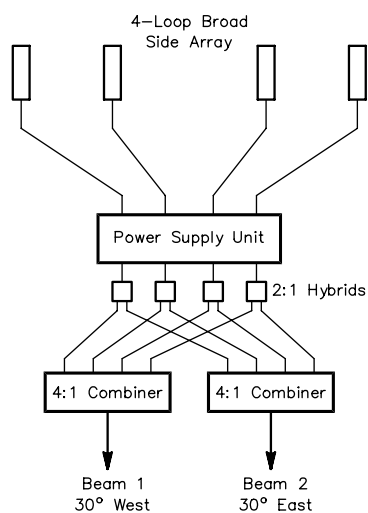
$$R_R = 3.12 \times 10^4 \left[ \frac{NA}{\lambda^2} \right]^2 \text{ ohms}$$

$$V_C = \sqrt{PX_L Q}$$

$$I_L = \sqrt{\frac{PQ}{X_L}}$$

where

- $X_L$  = inductive reactance, ohms
- $f$  = frequency, Hz
- $\Delta f$  = bandwidth, Hz
- $R_R$  = radiation resistance, ohms
- $R_L$  = loss resistance, ohms (see text)
- $N$  = number of turns
- $A$  = area enclosed by loop, square meters
- $\lambda$  = wavelength at operating frequency, meters
- $V_C$  = voltage across capacitor
- $P$  = power, watts
- $I_L$  = resonant circulating current in loop



**Fig 14—Block diagram of a four-loop broadside array with dual beams separated by 60° in azimuth.**

a tapped-capacitance impedance-matching network.

The Hart “high-efficiency” loop was introduced in the June 1986 *QST* by Ted Hart, W5QJR. It is shown schematically in Fig 15B and has the series tuning capacitor separate from the matching network. The Hart matching network is basically a form of gamma match. Other designs have used a smaller loop connected to the transmission line to couple into the larger transmitting loop.

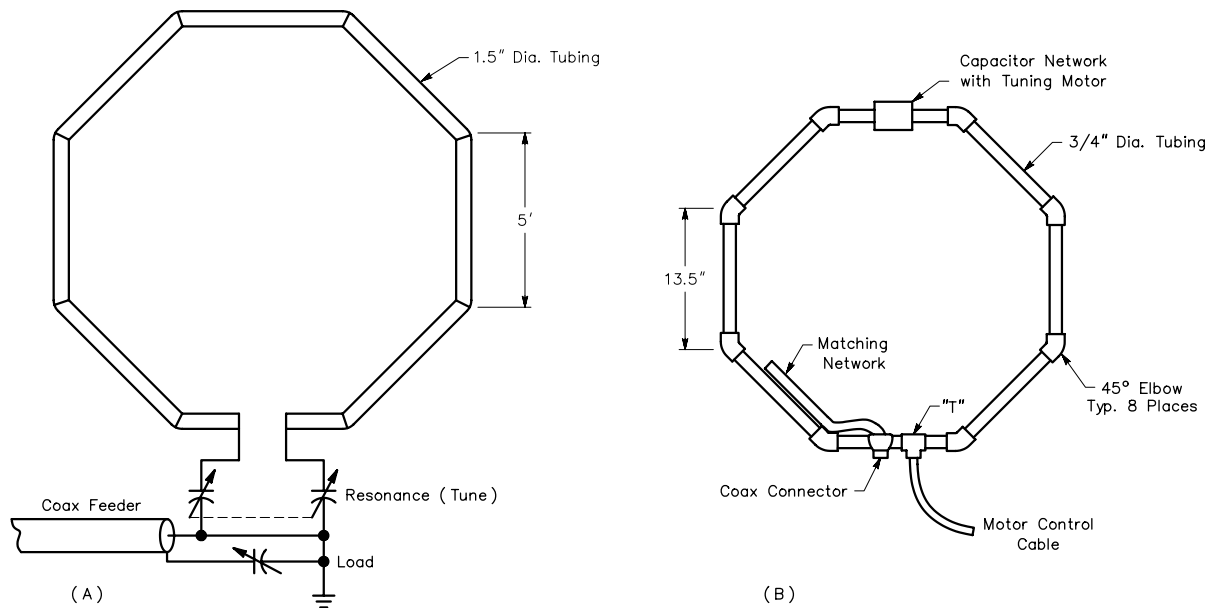
The approximate radiation resistance of a loop in ohms is given by

$$R_R = 3.12 \times 10^4 \left( \frac{NA}{\lambda^2} \right)^2 \quad (\text{Eq 13})$$

where

- $N$  = number of turns
- $A$  = area of loop in square meters
- $\lambda$  = wavelength of operation in meters

The radiation resistance of a small transmitting loop is usually very small. For example, a 1-meter diameter, single-turn circular loop has a radius of 0.5 meters and an enclosed area of  $\pi \times 0.5^2 = 0.785 \text{ m}^2$ . Operated at 14.0 MHz, the free-space wavelength is 21.4 meters and this leads to a computed



**Fig 15—At A, a simplified diagram of the army loop. At B, the W5QJR loop, which is described in more detail later in this chapter.**

radiation resistance of only  $3.12 \times 10^{-4} (0.785/21.4)^2 = 0.092 \Omega$ .

Unfortunately the loop also has losses, both ohmic and from skin effect. By using this information, the radiation efficiency of a loop can be calculated from

$$\eta = \frac{R_R}{R_R + R_L} \quad (\text{Eq 14})$$

where

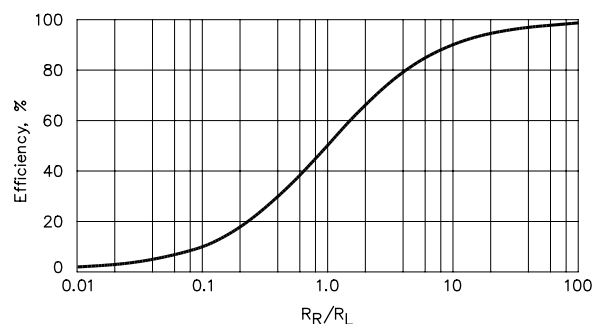
- $\eta$  = antenna efficiency, %
- $R_R$  = radiation resistance,  $\Omega$
- $R_L$  = loss resistance,  $\Omega$ , which includes the loop's conductor loss plus the loss in the series tuning capacitor.

A simple ratio of  $R_R$  versus  $R_L$  shows the effects on the efficiency, as can be seen from **Fig 16**. The loss resistance is primarily the ac resistance of the conductor. This can be calculated from Eq 6. A transmitting loop generally requires the use of copper conductors of at least  $3/4$  inch in diameter in order to obtain reasonable efficiency. Tubing is as useful as a solid conductor because high-frequency currents flow only along a very small depth of the surface of the conductor; the center of the conductor has almost no effect on current flow.

Note that the  $R_L$  term above also includes the effect of the tuning capacitor's loss. Normally, the unloaded  $Q$  of a capacitor can be considered to be so high that any loss in the tuning capacitor can be neglected. For example, a very high quality tuning capacitor with no mechanical wiping contacts, such as a vacuum-variable or a transmitting butterfly capacitor, might have an unloaded  $Q$  of about 5000. This

implies a series loss resistance of less than about  $0.02 \Omega$  for a capacitive reactance of  $100 \Omega$ . This relatively tiny loss resistance can become significant, however, when the radiation resistance of the loop is only on the order of  $0.1 \Omega$ ! Practical details for curbing capacitor losses are covered later in this chapter.

In the case of multiturn loops there is an additional loss related to a term called *proximity effect*. The proximity effect occurs in cases where the turns are closely spaced (such as being spaced one wire diameter apart). As these current-carrying conductors are brought close to each other, the current density around the circumference of each conductor gets redistributed. The result is that more current per square meter is flowing at the surfaces adjacent to other conductors. This means that the loss is higher than a simple



**Fig 16—Effect of ratio of  $R_R/R_L$  on loop efficiency.**

skin-effect analysis would indicate, because the current is bunched so it flows through a smaller cross section of the conductor than if the other turns were not present.

As the efficiency of a loop approaches 90%, the proximity effect is less serious. But unfortunately, the less efficient the loop, the worse the effect. For example, an 8-turn transmitting loop with an efficiency of 10% (calculated by the skin-effect method) actually only has an efficiency of 3% because of the additional losses introduced by the proximity effect. If you are contemplating construction of a multiturn transmitting loop, you might want to consider spreading the conductors apart to reduce this effect. G. S. Smith includes graphs that detail this effect in his 1972 IEEE paper.

The components in a resonated transmitting loop are subject to both high currents and voltages as a result of the large circulating currents found in the high-Q tuned circuit formed by the antenna. This makes it important that any fixed capacitors have a high RF current rating, such as transmitting micas or the Centralab 850 series. Be aware that even a 100-W transmitter can develop currents in the tens of amperes, and voltages across the tuning capacitor in excess of 10,000 V. This consideration also applies to any conductors used to connect the loop to the capacitors. A piece of #14 wire may have more resistance than the rest of the loop conductor!

It is therefore best to use copper strips or the braid from a piece of large coax cable to make any connections. Make the best electrical connection possible, using soldered or welded joints. Using nuts and bolts should be avoided, because at RF these joints generally have high resistance, especially after being subjected to weathering.

An unfortunate consequence of having a small but high-efficiency transmitting loop is high loaded Q, and therefore limited bandwidth. This type of antenna may require retuning for frequency changes as little as 5 kHz. If you are using any wide-band mode such as AM or FM, this might cause fidelity problems and you might wish to sacrifice a little efficiency to obtain the required bandwidth.

A special case of the transmitting loop is that of the ferrite loaded loop. This is a logical extension of the transmitting loop if we consider the improvement that a ferrite core makes in receiving loops. The use of ferrites in a transmitting loop is still under development. (See the Bibliography reference for DeVore and Bohley.)

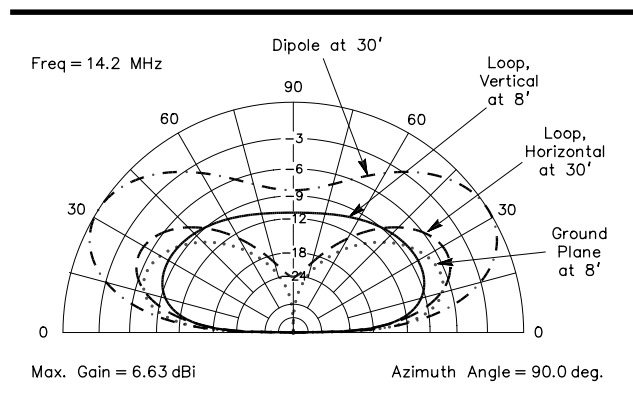
## PRACTICAL COMPACT TRANSMITTING LOOPS

The ideal small transmitting antenna would have performance equal to a large antenna. A small loop antenna can approach that performance except for a reduction in bandwidth, but that effect can be overcome by retuning. This section is adapted and updated from material written by Robert T. (Ted) Hart, W5QJR.

As pointed out above, small antennas are characterized by low radiation resistance. For a typical small antenna, such as a short dipole, loading coils are often added to achieve resonance. However, the loss inherent in the coils can result

in an antenna with low efficiency. If instead of coils a large, low-loss capacitor is added to a low-loss conductor to achieve resonance, and if the antenna conductor is bent to connect the ends to the capacitor, a loop is formed.

Based on this concept, the small loop is capable of relatively high efficiency, compared to its coil-loaded cousin. In addition, the small loop, when mounted vertically, can radiate efficiently over the wide range of elevation angles required on the lower frequency bands. This is because it has both high-angle and low-angle response. See Fig 17, which shows the elevation response for a compact transmitting loop only 16.2 inches wide at 14.2 MHz. This loop is vertically polarized and its bottom is 8 feet above average ground, which has a conductivity of 5 mS/m and a dielectric constant of 13. For comparison, Fig 17 also shows the responses of three other reference antennas—the same small loop flipped sideways at a height of 30 feet to produce horizontal radiation, a full-sized  $\lambda/4$  ground plane antenna mounted 8 feet above average ground using two tuned radials, and finally a simple  $\lambda/2$  flattop dipole mounted 30 feet above flat ground. The considerably smaller transmitting loop comes to within 3 dB of the larger  $\lambda/4$  vertical at a  $10^\circ$  elevation angle, and it is far stronger for high elevation angles because it does not have the null at high elevation angles that the ground plane has. Of course, this characteristic



**Fig 17—Elevation-plane plot at 14.2 MHz, showing response of an 8.5-foot circumference octagonal copper loop (width of 16.2 inches), compared to a full-sized  $\lambda/4$  ground-plane vertical with two elevated  $\lambda/4$  radials, the same small loop flipped horizontally at a height of 30 feet, and lastly, a  $\lambda/2$  flattop dipole also at a height of 30 feet. Both the  $\lambda/4$  ground-plane vertical and the vertically polarized loop are elevated 8 feet above typical ground, with  $\sigma = 5$  mS/m and  $\epsilon = 13$ . The low vertically polarized loop is surprisingly competitive, only down about 2.5 dB compared to the far larger ground plane at low elevation angles. Note that the vertical loop has both high-angle as well as low-angle radiation, and hence would be better at working close-in local stations than the ground-plane vertical, with its deep nulls at higher angles. The simple flattop dipole, however, is better than either vertical polarized compared to a horizontally polarized signal.**

does make it more susceptible to strong signals received at high elevation angles. Incidentally, just in case you were wondering, adding more radials to the  $\lambda/4$  ground plane doesn't materially improve its performance when mounted at an 8-foot height on 20 meters.

The simple horizontal dipole in Fig 17 would be the clear winner in any shootout because its horizontally polarized radiation does not suffer as much attenuation at reflection from ground as does a vertically polarized wave. The case is not quite so clear-cut, however, for the small loop mounted horizontally at 30 feet. While it does have increased gain at medium elevation angles, it may not be worth the effort needed to mount it on a mast, considering the slight loss at low angles compared to its twin mounted vertically only 8 feet above ground.

A physically small antenna like the 16.2-inch-wide vertically polarized loop does put out an impressive signal compared to far larger competing antennas. Though somewhat ungainly, it is a substantially better performer than most mobile whips, for example. The main deficiency in a compact transmitting loop is its narrow bandwidth—it must

be accurately tuned to the operating frequency. The use of a remote motor drive allows the loop to be tuned over a wide frequency range.

For example, for fixed-station use, two loops could be constructed to provide continuous frequency coverage from 3.5 to 30 MHz. A loop with an 8.5 foot circumference, 16 inches wide, could cover 10 through 30 MHz and a loop with a 20-foot circumference, 72 inches wide, could cover 3.5 to 10.1 MHz.

**Table 4** presents summary data for various size loop antennas for the HF amateur bands. Through computer analysis, the optimum size conductor was determined to be  $3/4$ -inch rigid copper water pipe, considering both performance and cost. Performance will be compromised, but only slightly, if  $5/8$ -inch flexible copper tubing is used. This tubing can easily be bent to any desired shape, even a circle. The rigid  $3/4$ -inch copper pipe is best used with  $45^\circ$  elbows to make an octagon.

The loop circumference should be between  $1/4$  and  $1/8 \lambda$  at the operating frequency. It will become self-resonant above  $1/4 \lambda$ , and efficiency drops rapidly below  $1/8 \lambda$ . In the

**Table 4**  
**Design Data for Loops**

**Loop Circumference = 8.5' (Width = 16.2"), Vertically Polarized**

Frequency, MHz	10.1	14.2	21.2	29.0
Max Gain, dBi	-4.47	-1.42	+1.34	+2.97
Max Elevation Angle	40°	30°	22°	90°
Gain, dBi @ 10°	-8.40	-4.61	-0.87	+0.40
Total Capacitance, pF	145	70	29	13
Peak Capacitor kV	23	27	30	30

**Loop Circumference = 8.5' (Width = 16.2"), Horizontally Polarized, @30'**

Frequency, MHz	10.1	14.2	21.2	29.0
Max Gain, dBi	-3.06	+1.71	+5.43	+6.60
Max Elevation Angle	34°	28°	20°	16°
Gain, dBi @ 10°	-9.25	-3.11	+2.61	+5.34
Total Capacitance, pF	145	70	29	13
Peak Capacitor kV	23	27	30	30

**Loop Circumference = 20' (Width = 6'), Vertically Polarized**

Frequency, MHz	3.5	4.0	7.2	10.1
Max Gain, dBi	-7.40	-6.07	-1.69	-0.34
Max Elevation Angle	68°	60°	38°	30°
Gain, dBi @ 10°	-11.46	-10.12	-5.27	-3.33
Capacitance, pF	379	286	85	38
Peak Capacitor kV	22	24	26	30

**Loop Circumference = 20' (Width = 6'), Horizontally Polarized, @30'**

Frequency, MHz	3.5	4.0	7.2	10.1
Max Gain, dBi	-13.32	-10.60	-0.20	+3.20
Max Elevation Angle	42°	42°	38°	34°
Gain, dBi @ 10°	-21.62	-18.79	-7.51	-3.22
Capacitance, pF	379	286	85	38
Peak Capacitor kV	22	24	26	30

**Loop Circumference = 38' (Width = 11.5'), Vertically Polarized**

Frequency, MHz	3.5	4.0	7.2
Max Gain, dBi	-2.93	-2.20	-0.05
Max Elevation Angle	46°	42°	28°
Gain, dBi @ 10°	-6.48	-5.69	-2.80
Capacitance, pF	165	123	29
Peak Capacitor kV	26	27	33

**Notes:** These loops are octagonal in shape, constructed with  $3/4$ -inch copper water pipe and soldered  $45^\circ$  copper elbows. The gain figures assume a capacitor unloaded  $Q_C = 5000$ , typical for vacuum-variable type of tuning capacitor. The bottom of the loop is assumed to be 8 feet high for safety and the ground constants are "typical" at conductivity = 5 mS/m and dielectric constant = 13. Transmitter power is 1500 W. The voltage across the tuning capacitor for lower powers goes

down with a multiplier of  $\sqrt{\frac{P}{1500}}$ . For example, at 100 W using the 38-foot-circumference loop at 7.2 MHz, the peak voltage would be  $33\text{kV} \times \sqrt{\frac{100}{1500}} = 8.5 \text{ kV}$ .



frequency ranges shown in Table 4, the high frequency is tuned with a minimum capacitance of about 29 pF—including stray capacitance.

The low frequency listed in Table 4 is that where the loop response is down about 10 dB from that of a full-sized elevated ground plane at low elevation angles suitable for DX work. Fig 18 shows an overlay at 3.5 MHz of the elevation responses for two loops: one with an 8.5-foot circumference and one with a 20-foot circumference, together with the response for a full-sized 80-meter ground plane elevated 8 feet off average ground with 2 tuned radials. The 20-foot circumference loop holds its own well compared to the full-sized ground plane.

### Controlling Losses

Contrary to earlier reports, adding quarter-wave ground radials underneath a vertically polarized transmitting loop doesn't materially increase loop efficiency. The size of the conductor used for a transmitting loop, however, does directly affect several interrelated aspects of loop performance.

Data for Table 4 was computed for 3/4-inch copper water pipe (nominal OD of 0.9 inch). Note that the efficiency is higher and the Q is lower for loops having a circumference near 1/4 λ. Larger pipe size will reduce the loss resistance, but the Q increases. Therefore the bandwidth decreases, and the voltage across the tuning capacitor increases. The voltage across the tuning capacitor for high-power operation can become very impressive, as shown in Table 4. Rigid 3/4-inch copper water pipe is a good electrical compromise and can also help make a small-diameter loop mechanically sturdy.

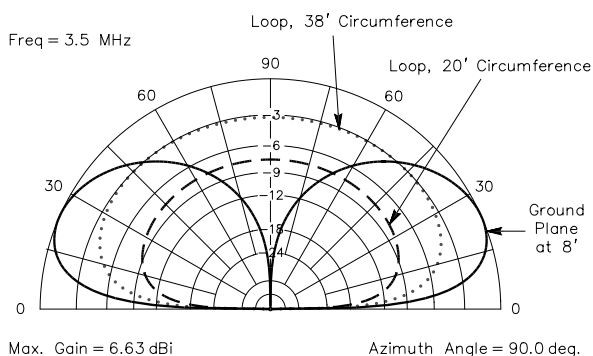
The equivalent electrical circuit for the loop is a parallel resonant circuit with a very high Q, and therefore a narrow bandwidth. The efficiency is a function of radiation resistance divided by the sum of the radiation plus loss resistances. The radiation resistance is much less than 1 Ω, so it is necessary to minimize the loss resistance, which is largely the skin effect loss of the conductor, assuming that the tuning capacitor has very low loss. Poor construction techniques must be avoided. All joints in the loop must be brazed or soldered.

However, if the system loss is too low, for example by using even larger diameter tubing, the Q may become excessive and the bandwidth may become too narrow for practical use. These reasons dictate the need for a complete analysis to be performed before proceeding with the construction of a loop.

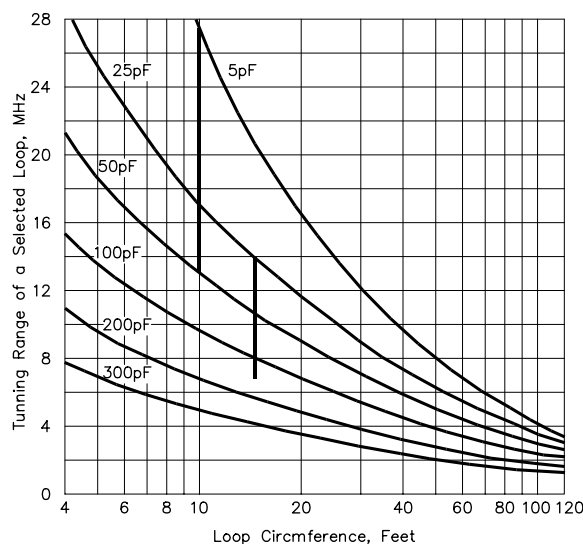
There is another source of additional loss in a completed loop antenna besides the conductor and capacitor losses. If the loop is mounted near lossy metallic conductors, the large magnetic field produced will induce currents into those conductors and be reflected as losses in the loop. Therefore the loop should be as far from other conductors as possible. If you use the loop inside a building constructed with large amounts of iron or near ferrous materials, you will simply have to live with the loss if the loop cannot otherwise be relocated.

### The Tuning Capacitor

Fig 19 demonstrates the selection of loop size versus tuning capacitance for any desired operating frequency range for the HF amateur bands. This is for octagonal-shaped loops using 3/4-inch copper water pipe with 45° copper elbows.



**Fig 18—Elevation-plane response of three antennas at 3.5 MHz—a 20-foot circumference octagonal copper loop, a 38-foot circumference copper loop and a full-sized λ/4 ground plane with two elevated radials. The bottom of each antenna is mounted 8 feet above ground for safety. The 38-foot circumference loop (which has a “wingspan” of 11.5 feet) is fairly competitive with the much large ground-plane, being down only about 4 dB at low elevation angles. The 20-foot circumference loop is much more lossy, but with its top only about 14 feet off the ground is very much of a “stealth” antenna.**



**Fig 19—Frequency tuning range of an octagon-shaped loop using 3/4-inch copper water pipe, for various values of tuning capacitance and loop circumference.**

For example, a capacitor that varies from 5 to 50 pF, used with a loop 10 feet in circumference, tunes from 13 to 27 MHz (represented by the left dark vertical bar). A 25 to 150 pF capacitor with a 13.5-foot loop circumference covers the 7 to 14.4 MHz range, represented by the right vertical bar.

**Fig 20** illustrates how the 29-MHz elevation pattern becomes distorted and rather bulbous-looking for the 10-foot circumference loop, although the response at low elevation angles is still better than that of a full-sized ground-plane antenna.

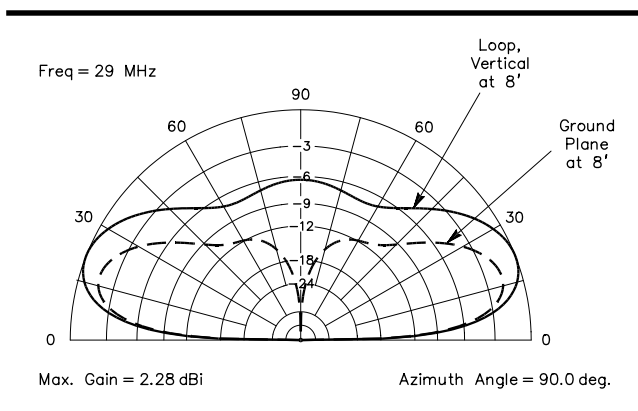
### Air Variable Capacitors

Special care must be taken with the tuning capacitor if an air-variable type is used. The use of a split-stator capacitor eliminates the resistance of wiper contacts, resistance that is inherent in a single-section capacitor. The ends of the loop are connected to the stators, and the rotor forms the variable coupling path between the stators. With this arrangement the value of capacitance is divided by two, but the voltage rating is doubled.

You must carefully select a variable capacitor for transmitting-loop application—that is, all contacts must be welded, and no mechanical wiping contacts are allowed. For example, if the spacers between plates are not welded to the plates, there will be loss at each joint, and thus degraded loop efficiency. (Earlier transmitting loops exhibited poor efficiency because capacitors with wiping contacts were used.)

There are several suitable types of capacitors for this application. A vacuum variable is an excellent choice, provided one is selected with an adequate voltage rating. Unfortunately, those capacitors are very expensive.

W5QJR used a specially modified air-variable capacitor in his designs. This had up to 340 pF maximum per section, with 1/4-inch spacing, resulting in 170 pF when both sections were in series as a butterfly capacitor. Another



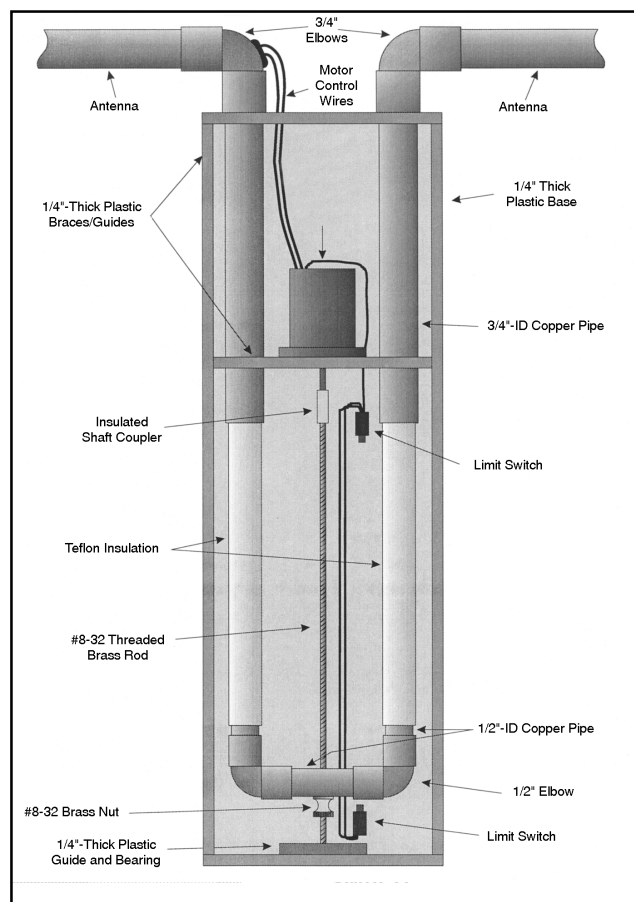
**Fig 20**—Elevation-plane plot for a 16.2-inch wingspan octagonal copper loop at 29 MHz, compared to a 1/4 ground-plane antenna with two resonant elevated radials. The gains at low angles are almost identical, but the loop exhibits more gain at medium and high elevation angles. Again, the bottom of each antenna is located 8 feet above ground for safety.

alternative is to obtain a large air variable, remove the aluminum plates, and replace them with copper or double-sided PC board material to reduce losses. Connect all plates together on the rotor and on the stators. Solder copper straps to the capacitor for soldering to the loop itself.

The spacing between plates in an air-variable capacitor determines the voltage-handling capability, rated at 75,000 V per inch. For other power ratings, multiply the spacing (and voltage) by the square root of the ratio of your power to 1000 W. For example, for 100 W, the ratio would be = 0.316.

### A Teflon-Insulated Trombone Variable Capacitor

Another type of variable capacitor discussed in the amateur literature for use with a compact transmitting loop is the so-called “trombone” type of capacitor. **Fig 21** shows a practical trombone capacitor created by [Bill Jones, KD7S](#), for Nov 1994 *QST*. This capacitor uses downward pointing extensions of the two 3/4-inch OD main conductor copper pipes, with a Teflon-insulated trombone section made of 1/2-inch ID copper pipe. The trombone telescopes into the main pipes, driven by a lead screw and a 180-rpm gear-head



**Fig 21**—A practical trombone capacitor designed by [Bill Jones, KD7S](#), for his compact transmitting loop. This capacitor has a tuning range from 12 to almost 60 pF, and can withstand at least 5 kV peak. The 10-inch 1/2-inch ID tubes are covered with Teflon-sheet insulation and slide into the 3/4-inch ID copper pipes.

motor. Like the butterfly air variable capacitor, the trombone works without lossy wiper contacts. Jones' capacitor varied from 12 pF (including strays) to almost 60 pF, making it suitable to tune his 3-foot circumference loop from 14 to 30 MHz at the 100-W level.

KD7S used 5-mil (0.005 inch) thick Teflon sheet as an insulator. Since Teflon is conservatively rated at more than 1 kV per mil of thickness, the voltage breakdown capability of this capacitor is well in excess of 5 kV. The parts list is given in **Table 5**.

A short length of plastic tubing connects the threaded brass rod to the motor. The tubing acts as an insulator and a flexible coupling to smooth out minor shaft-alignment errors. The other end of the rod is threaded into a brass nut soldered to the crossbar holding the 1/2-inch pipes together. Jones used a 12-V motor rated at 180 rpm, but it has sufficient torque to work with as little as 4 V applied. Instead of a sophisticated variable duty-cycle speed control circuit, he used an LM327 adjustable voltage regulator to vary the motor-control voltage from 4 to 12 V. Tuning speeds ranged from 11 seconds per inch at 12 V to 40 seconds per inch at 4 V. The higher speed is necessary to jump from band to band in a reasonable length of time. The lower speed makes it easy to fine-tune the capacitor to any desired frequency within a band.

When building the capacitor, keep in mind that the smaller tubes must telescope in and out of the larger tubes with silky smoothness. Any binding will cause erratic tuning. For the same reason, the #8-32 brass threaded rod must be

straight and properly aligned with the brass nut. *Take your time with this part of the project.*

Perhaps the easiest way to form the insulator is to pre-cut a length of Teflon sheet to the proper size. Place a lengthwise strip of double-sided tape on the tube to secure one end of the Teflon sheet. Begin wrapping the Teflon around the tube while keeping it as tight as possible. *Don't allow wrinkles or ridges to form.* Secure the other end with another piece of tape. Once both tubes are covered, ensure they are just short of being a snug fit inside the larger tubes. Confirm that the insulation completely overlaps the open end of the small tubes. If not, the capacitor is certain to arc internally with more than a few watts of power applied to it.

Route the motor wiring inside the antenna pipes to minimize the amount of metal within the field of the antenna. Bring the wires out next to the coaxial connector. A three-wire system allows the use of limit switches to restrict the movement of the trombone section. Be sure to solder together all metal parts of the capacitor. Use a small propane torch, a good quality flux and 50/50 solid solder. Do not use acid-core solder! Clean all parts to be joined with steel wool prior to coating them with flux.

### A Cookie-Sheet and Picture-Frame-Glass Variable Capacitor

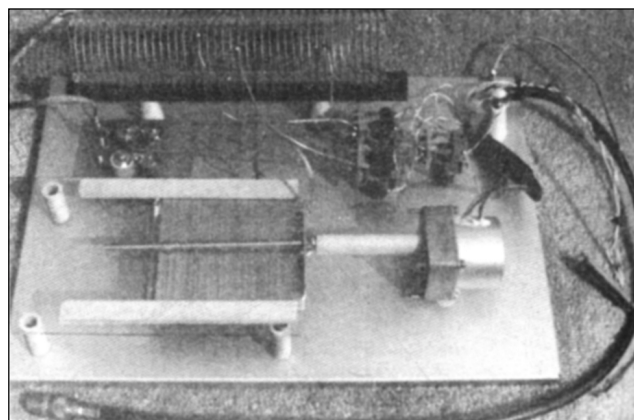
In Vol 2 of *The ARRL Antenna Compendium* series, [Richard Plasencia, W0RPV](#), described a clever high-voltage variable capacitor he constructed using readily available materials. See **Fig 22**, which shows Plasencia's homebrew high-voltage variable capacitor, along with the coil and other parts used in his homemade antenna coupler. This capacitor could be varied from 16 to 542 pF and tested at a breakdown of 12,000 V.

The capacitor sits on four PVC pillars and consists of two 4 1/2 x 4 1/2-inch aluminum plates separated by a piece of window glass that is 8 1/2 x 5 1/2 inches in size. The lower

**Table 5**

#### KD7S Loop-Tuning Capacitor Parts List for Nominal 50-pF Capacitor

Qty	Description
2	10-inch length of 3/4-inch-ID type M copper water pipe
2	10-inch length of 1/2-inch-ID type M copper water pipe
1	3-inch length of 1/2-inch-ID type M copper water pipe
2	1/2-inch, 90° copper elbows
2	3/4-inch, 90° copper elbows
2	10 x 22-inch piece of 0.005-inch-thick Teflon sheet plastic
1	12-inch length of #8-32 threaded brass rod
1	#8-32 brass shoulder nut
2	22 x 5 1/2 x 1/4-inch ABS plastic sheet (top and bottom covers)
3	1 x 5 1/2 x 1/4-inch ABS plastic sheet (end pieces and center) brace/guide
2	1 x 22 x 1/4-inch ABS plastic sheet (side rails)
1	50 to 200-rpm gear-head dc motor
1	DPDT center-off toggle switch (up/down control)
2	SPDT microswitches (limit switches)
50 feet	3-conductor control cable
1	Enclosure for control switch



**Fig 22**—The picture-frame-glass variable capacitor design of Richard Plasencia, W0RPV. Two aluminum plates separated by a piece of glass scavenged from a picture frame create a variable capacitor that can withstand 12,000 V, with a variable range from 16 to 542 pF.

plate is epoxied to the glass. The upper plate is free to move in a wooden track epoxied to the upper surface of the glass. The motor is reversible and moves the upper capacitor plate by rotating a threaded rod in a wing nut pinned to a tab on the capacitor plate. The four pillars are cut from PVC pipe to insulate the capacitor from the chassis and to elevate it into alignment with the motor shaft.

WORPV used a piece of 0.063-inch thick single-weight glass that exhibited a dielectric constant of 8. He removed the glass from a dime-store picture frame. In time-honored ham fashion, he improvised his wooden tracks for the upper capacitor plate from a single wooden paint stirrer, and for the capacitor plates, he used aluminum cookie sheets.

The wooden track for the upper plate is made by splitting the wooden paint stirrer with a knife into one narrow and one wide strip. The narrow strip is cemented on top and overhangs the movable plate, creating a slotted track. Since the wood is supported by the glass plate, its insulating qualities are of no importance.

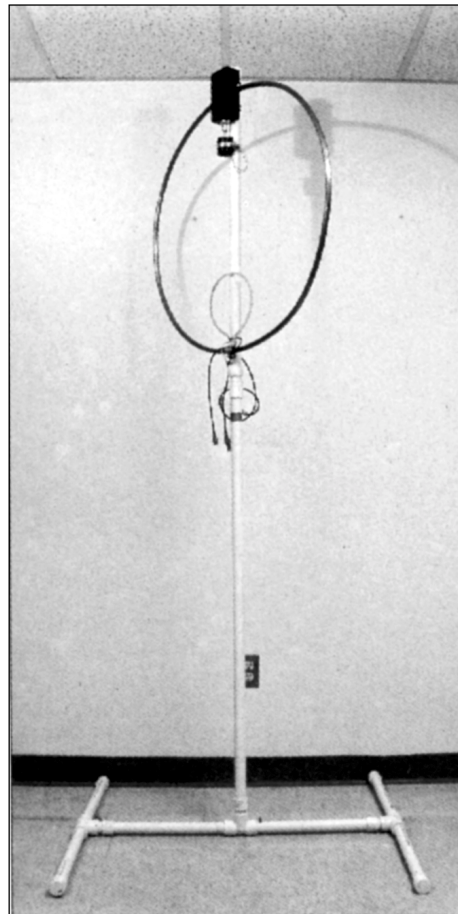
The principle of operation is simple. The reversible motor turns a threaded  $\frac{1}{4}$ -inch rod with a pitch of 20 threads to the inch. This rod engages a wing nut attached to the movable capacitor plate. Although WORPV grounded his capacitor's movable plate with a braid, an insulator similar to that used in the trombone capacitor above should be used to isolate the lead-screw mechanism. Several pieces of braid made from RG-8 coax shield should be used to connect to the ends of the compact transmitting loop conductors to form low-loss connections.

WORPV used a 90-rpm motor from a surplus vending machine. It moved his variable capacitor plate  $4\frac{1}{2}$  inches, taking about a minute to travel from one end to the other. Since he wished to eliminate the complexity and dubious reliability of limit switches when used outdoors, he monitored the motor's dc current through two  $3\ \Omega$ , 2-W resistors placed in series with each lead of the motor and shunted by red LEDs at the control box. When the motor stalled by jamming up against the PVC limit stop or against the inside of the plastic mounting box, the increased motor current caused one or the other of the LEDs to light up.

### TYPICAL LOOP CONSTRUCTION

After you select the electrical design for your loop application, you must consider how to mount it and how to feed it. If you wish to cover only the upper HF bands of 20 through 10 meters, you will probably choose a loop that has a circumference of about 8.5 feet. You can make a reasonably sturdy loop using 1-inch diameter PVC pipe and  $\frac{5}{8}$ -inch flexible copper tubing bent into the shape of a circle. [Robert Capon, WA3ULH](#), did this for a QRP-level transmitting loop described in May 1994 *QST*. **Fig 23** shows a picture of his loop, with PVC H-frame stand.

This loop design used a 20-inch long coupling loop made of RG-8 coax to magnetically couple into the transmitting loop rather than the gamma-match arrangement used by W5QJR in his loop designs. The coupling loop was



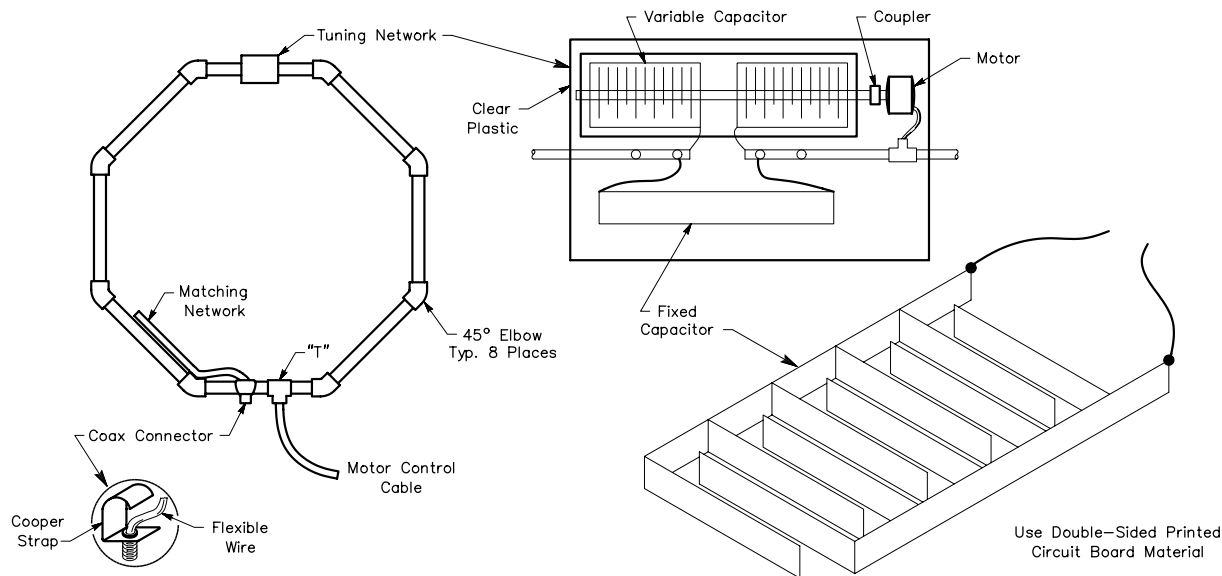
**Fig 23**—Photo of compact transmitting loop designed by Robert Capon, WA3ULH. This uses a 1-inch PVC H-frame to support the loop made of flexible  $\frac{5}{8}$ -inch copper tubing. The small coupling loop made of RG-8 coax braid couples the loop to the coax feed line. The tuning capacitor and drive motor are at the top of the loop, shown here in the ARRL Laboratory during testing.

fastened to the PVC pipe frame using 2-inch long #8 bolts that also held the main loop to the mast.

A more rugged loop can be constructed using rigid  $\frac{3}{4}$ -inch copper water pipe, as shown in the W5QJR design in **Fig 24**. While a round loop is theoretically a bit more efficient, an octagonal shape is much easier to construct. The values presented in [Table 4](#) are for octagons.

For a given loop circumference, divide the circumference by 8 and cut eight equal-length pieces of  $\frac{3}{4}$ -inch copper water pipe. Join the pieces with  $45^\circ$  elbows to form the octagon. With the loop lying on the ground on scraps of  $2 \times 4$  lumber, braze or solder all joints.

W5QJR made a box from clear plastic to house his air-variable capacitor and drive motor at the top of the loop. The side of the box that mounts to the loop and the capacitor should be at least  $\frac{1}{4}$ -inch thick, preferably  $\frac{3}{8}$  inch. The remainder of the box can be  $\frac{1}{8}$ -inch plastic sheet. He mounted the loop to the plastic using  $\frac{1}{4}$ -inch bolts (two on



**Fig 24—Octagonal loop construction details. Table 4 gives loop design data for various frequency ranges.**

either side of center) after cutting out a section of pipe 2 inches wide in the center. On the motor side of the capacitor, he cut the pipe and installed a copper T for the motor wiring.

W5QJR's next step was to solder copper straps to the loop ends and to the capacitor stators, then he remounted the loop to the plastic. If you insert wood dowels, the pipe will remain round when you tighten the bolts. Next he installed the motor drive cable through the loop and connected it to the motor. Antenna rotator cable is a good choice for this cable. He completed the plastic box using short pieces of aluminum angle and small sheet-metal screws to join the pieces.

The loop was then ready to raise to the vertical position. Remember, no metal is allowed near the loop. W5QJR made a pole of 2×4-inch lumber with 1×4-inch boards on either side to form an I section. He held the boards together with 1/4-inch bolts, 2 feet apart and tied rope guys to the top. This made an excellent mast up to 50 feet high. The pole height should be one foot greater than the loop diameter, to allow room for cutting grass or weeds at the bottom of the loop. W5QJR installed a pulley at the top so that his loop could be raised, supported by rope. He supported the bottom of the loop by tying it to the pole and tied guy ropes to the sides of the loop to keep it from rotating in the wind. By moving the anchor points, he could rotate his loop in the azimuth plane.

W5QJR used a gamma-matching arrangement made of flexible 1/4-inch copper tubing to couple the loop to the transmission line. In the center of one leg, he cut the pipe and installed a copper T. Adjacent to the T, he installed a

mount for the coax connector. He made the mount from copper strap, which can be obtained by splitting a short piece of pipe and hammering it flat.

While the loop was in the vertical position he cut a piece of 1/4-inch flexible copper tubing the length of one of the straight sides of the loop. He then flattened one end and soldered a piece of flexible wire to the other. He wrapped the tubing with electrical tape for insulation and connected the flexible wire to the coax connector. He then installed the tubing against the inside of the loop, held temporarily in place with tape. He soldered the flat part to the loop, ending up with a form of gamma match, but without reactive components. This simple feed provided better than 1.7:1 SWR over a 2:1 frequency range. For safety, he installed a good ground rod under the loop and connected it to the strap for the coax connector, using large flexible wire.

### TUNE-UP PROCEDURE

The resonant frequency of the loop can be readily found by setting the receiver to a desired frequency and rotating the capacitor (by remote control) until signals peak. The peak will be very sharp because of the high Q of the loop.

Turn on the transmitter in the tune mode and adjust either the transmitter frequency or the loop capacitor for maximum signal on a field-strength meter, or for maximum forward signal on an SWR bridge. Adjust the matching network for minimum SWR by bending the matching line. Normally a small hump in the 1/4-inch tubing line, as shown in Fig 24, will give the desired results. For a loop that covers two or more bands, adjust the feed to give equally low SWR at each end of the tubing range. The SWR will be very low

in the center of the tuning range but will rise at each end.

If there is metal near the loop, the additional loss will reduce the Q and therefore the impedance of the loop. In those cases it will be necessary to increase the length of the matching line and tap higher up on the loop to obtain a 50-Ω match.

### PERFORMANCE COMPARISON

As previously indicated, a compact transmitting loop can provide performance approaching full-size dipoles and verticals. To illustrate one case, a loop 100 feet in circumference would be 30 feet high for 1.8 MHz. However, a good dipole would be 240 feet ( $1/2 \lambda$ ) in length and at least 120 feet high ( $1/4 \lambda$ ). A  $1/4\text{-}\lambda$  vertical would be 120 feet tall with a large number

of radials on the ground, each 120 feet in length. The smaller loop could replace both of those antennas with only a moderate degradation in performance and a requirement for a high-voltage variable capacitor.

On the higher frequencies, the same ratios apply, but full-size antennas are less dramatic. However, very few city dwellers can erect good verticals even on 7 MHz with a full-size counterpoise. Even on 14 MHz a loop about 3 feet high can work the world.

Other than trading small size for narrow bandwidth and a high-voltage capacitor, the compact transmitting loop is an excellent antenna and should find use where large antennas are not practical.

## The Loop Skywire

Are you looking for a multiband HF antenna that is easy to construct, costs nearly nothing and yet works well? You might want to try this one. The *Loop Skywire* antenna is a full-sized horizontal loop. Early proponents suggested that the antenna could be fed with coaxial cable with little concern for losses, but later analysis proved that this was a bit of wishful thinking—the relatively low values for SWR across multiple bands indicate that cable losses were part and parcel performance. The best way to feed this versatile antenna is with open-wire ladder line, with an antenna tuner in the shack to present the transmitter with a low value of SWR.

### THE DESIGN

The Loop Skywire is shown in **Fig 25**. The antenna has one wavelength of wire in its perimeter at the design or fundamental frequency. If you choose to calculate  $L_{\text{total}}$  in feet, the following equation should be used:

$$L_{\text{total}} = \frac{1005}{f}$$

where f equals the frequency in MHz.

Given any length of wire, the maximum possible area the antenna can enclose is with the wire in the shape of a

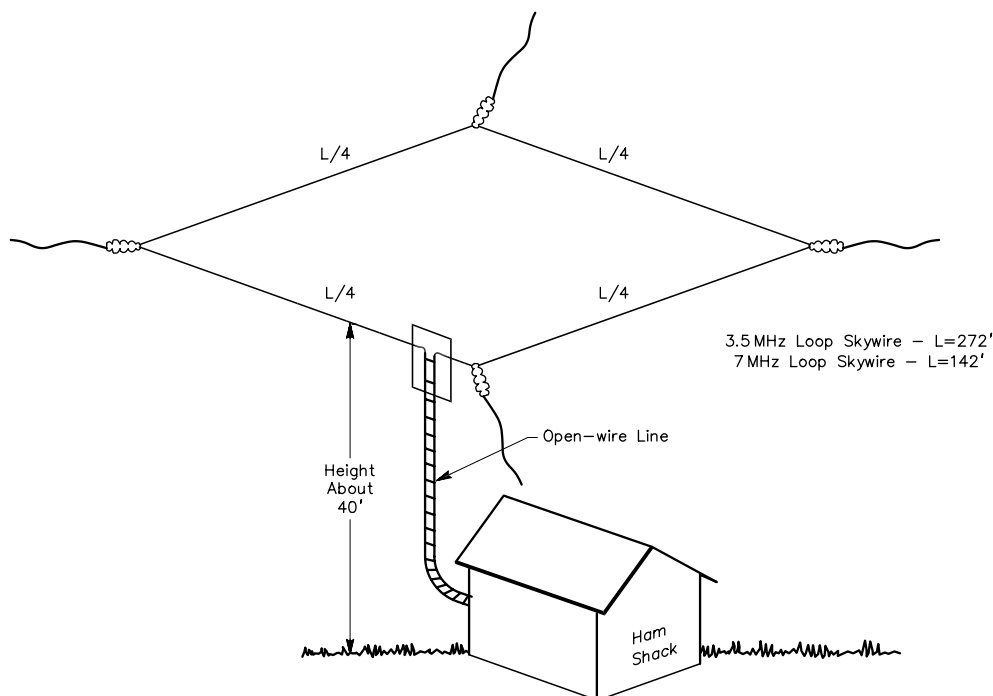


Fig 25—A complete view of the Loop Skywire. The square loop is erected horizontal to the earth.

circle. Since it takes an infinite number of supports to hang a circular loop, the square loop (four supports) is the most practical. Further reducing the area enclosed by the wire loop (fewer supports) brings the antenna closer to the properties of the folded dipole, and both harmonic-impedance and feed-line voltage problems can result. Loop geometries other than a square are thus possible, but remember the two fundamental requirements for the Loop Skywire—its horizontal position and maximum enclosed area.

There is another great advantage to this antenna system. It can be operated as a vertical antenna with top-hat loading on other bands as well. This is accomplished by simply keeping the feed line run from the antenna to the shack as vertical as possible and clear of objects. Both feed-line conductors are then tied together, and the antenna is fed against a good ground.

### CONSTRUCTION

Antenna construction is simple. Although the loop can be made for any band or frequency of operation, the following two Loop Skywires are good performers. The 10-MHz band can also be operated on both.

#### 3.5-MHz Loop Skywire

(3.5-28 MHz loop and 1.8-MHz vertical)

Total loop perimeter: 272 feet

Square side length: 68 feet

#### 7-MHz Loop Skywire

(7-28 MHz loop and 3.5-MHz vertical)

Total loop perimeter: 142 feet

Square side length: 35.5 feet

The actual total length can vary from the above by a few feet, as the length is not at all critical. Do not worry about tuning and pruning the loop to resonance. No signal

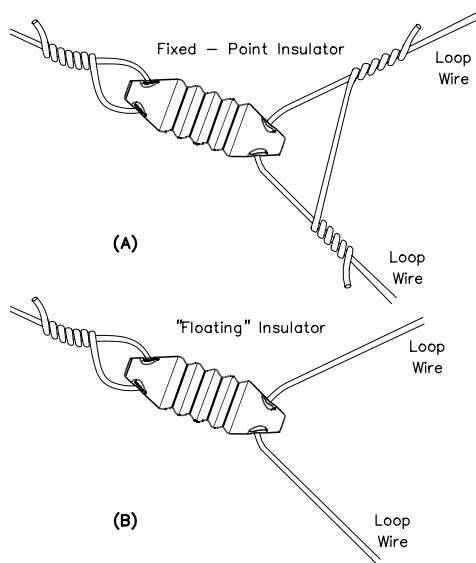


Fig 26—Two methods of installing the insulators at the loop corners.

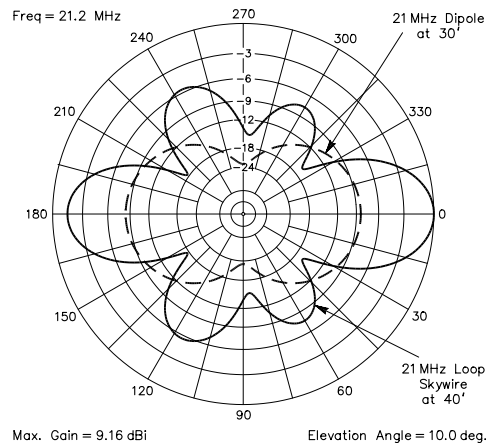
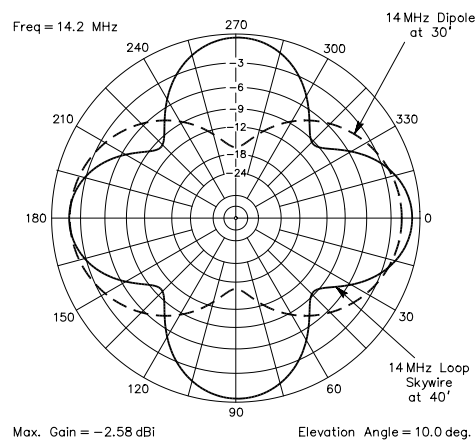
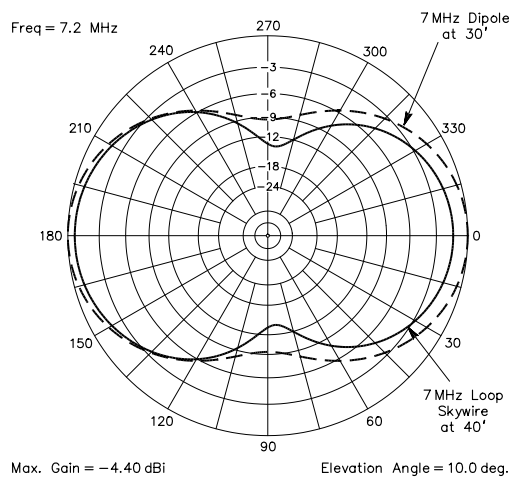


Fig 27—At A, azimuth-plane response of 142-foot long, 7-MHz Loop Skywire, 40 feet in the air at 7.2 MHz, compared with  $1/2\text{-}\lambda$  dipole 30 feet in the air. At B, response of same Loop Skywire at 14.2 MHz, compared with  $1/2\text{-}\lambda$  14.2-MHz dipole 30 feet in the air. Now the loop has some advantage in certain directions. At C, response of the same Loop Skywire at 21.2 MHz compared to a 21.2-MHz dipole at 30 feet. Here, the Loop Skywire has more gain in almost all directions than the simple dipole. All azimuth-plane patterns were made at 10° elevation.

difference will be detected on the other end when that method is used.

Bare #14 copper wire is used in the loop. Fig 26 shows the placement of the insulators at the loop corners. Two common methods are used to attach the insulators. Either lock or tie the insulator in place with a loop wire tie, as shown in Fig 26A, or leave the insulator free to “float” or slide along the wire, Fig 26B. Most loop users float at least two insulators. This allows pulling the slack out of the loop once it is in the air, and eliminates the need to have all the supports exactly placed for proper tension in each leg. Floating two opposite corners is recommended.

Fig 27A shows the azimuth-plane performance on 7.2 MHz of a 142-foot long, 7-MHz Loop Skywire, 40 feet high at an elevation angle of 10°, compared to a regular flattop  $\frac{1}{2}\lambda$  dipole at a height of 30 feet. The loop comes into its own at higher frequencies. Fig 27B shows the response at 14.2 MHz, compared again to a  $\frac{1}{2}\lambda$  14.2-MHz dipole at a height of 30 feet. Now the loop has several lobes that are stronger than the dipole. Fig 27C shows the response at 21.2 MHz, compared to a dipole. Now the loop has superior gain compared to the  $\frac{1}{2}\lambda$  dipole at almost any azimuth. In its favored direction on 21.2 MHz, the loop is 8 dB stronger than the dipole.

The feed point can be positioned anywhere along the loop that you wish. However, most users feed the Skywire at a corner. Fig 28 depicts a method of doing this, using a piece of plexiglass to provide insulation as well as strain relief for the open-wire ladder line. It is advantageous to keep the feed-point mechanicals away from the corner support. Feeding a foot or so from one corner allows the feed line to exit more freely. This method keeps the feed line free from the loop support.

Generally a minimum of four supports is required. If trees are used for supports, then at least two of the ropes or guys used to support the insulators should be counterweighted and allowed to move freely. The feed-line corner is almost always tied down, however. Very little tension is needed to support the loop (far less than that for a dipole). Thus, counterweights are light. Several such loops have been constructed with bungee cords tied to three of the four insulators. This eliminates the need for counterweighting.

Recommended height for the antenna is 40 feet or more. The higher the better, especially if you wish to use the loop in the vertical mode. However, successful local and DX operation has been reported in several cases with the antenna at 20 feet. Fig 29 shows the feed arrangement for using the Loop Skywire as a top-loaded vertical fed against ground on the lower bands.

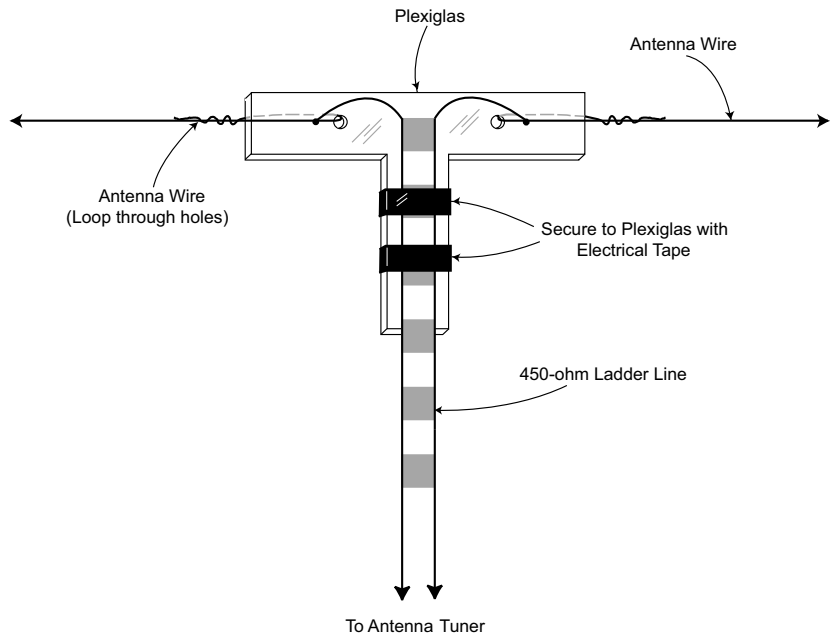


Fig 28—Most users feed the Skywire at a corner. A high-impedance weather-resistant insulator should be used for the feed-point insulator.

Because the loop is high in the air and has considerable electrical exposure to the elements, proper methods should be employed to eliminate the chance of induced or direct lightning hazard to the shack and operator. Some users simply completely disconnect the antenna from the antenna tuner and rig and shack during periods of possible lightning activity.

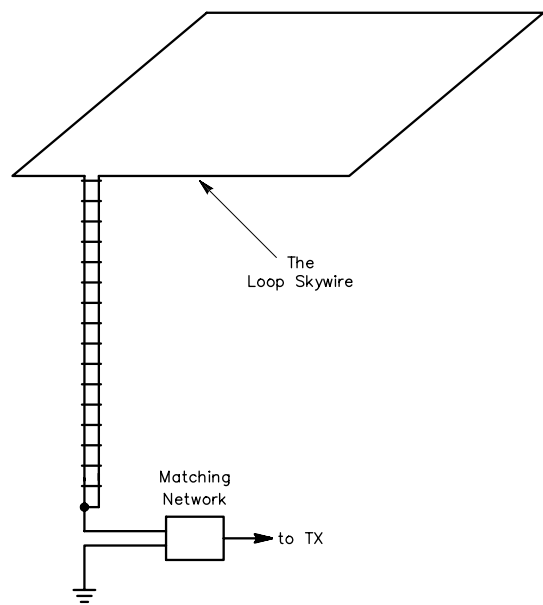


Fig 29—The feed arrangement for operating the 7-MHz Loop Skywire as a vertical antenna.



# 7-MHz Loop

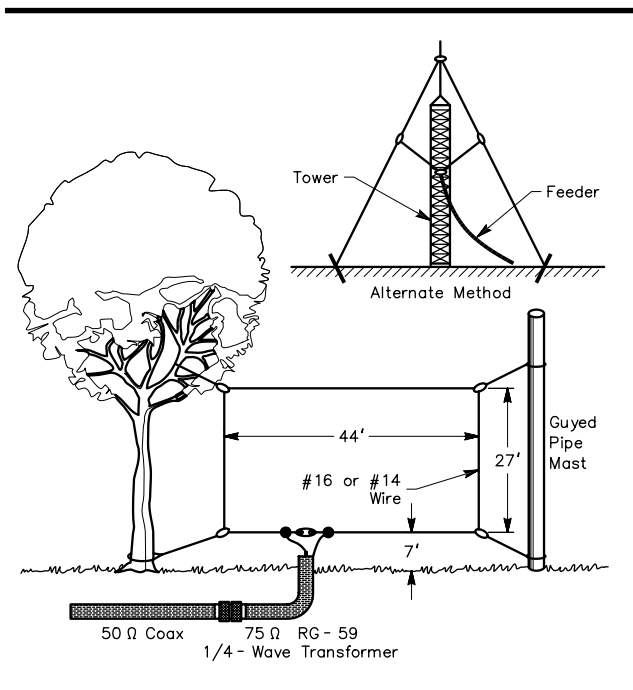
An effective but simple 7-MHz antenna that has a theoretical gain of approximately 2 dB over a dipole is a full-wave, closed vertical loop. Such a loop need not be square, as illustrated in **Fig 30**. It can be trapezoidal, rectangular, circular, or some distorted configuration in between those shapes. For best results, however, the builder should attempt to make the loop as square as possible. The more rectangular the shape, the greater the cancellation of energy in the system, and the less effective it will be. In the limiting case, the antenna loses its identity as a loop and becomes a folded dipole.

The loop can be fed in the center of one of the vertical sides if vertical polarization is desired. For horizontal polarization, it is necessary to feed either of the horizontal sides at the center. Optimum directivity occurs at right angles to the plane of the loop, or in more simple terms, broadside from the loop. One should try to hang the system from available supports which will enable the antenna to radiate the maximum amount in some favored direction. **Fig 31** shows how the elevation pattern changes with changes in

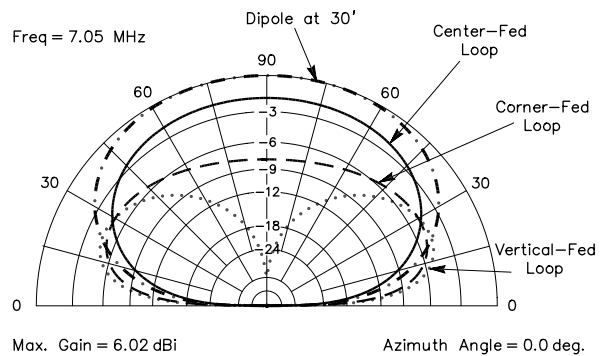
the feed-point location. For DX work, the optimal feed point for vertical polarization is in the center of one of the vertical wires. Feeding the loop at one of the corners at the bottom gives a good compromise for local and DX work. The actual impedance is roughly the same at each point: bottom horizontal center, corner or side center.

Just how the wire is erected will depend on what is available in one's yard. Trees are always handy for supporting antennas, and in many instances the house is high enough to be included in the lineup of solid objects from which to hang a radiator. If only one supporting structure is available, it should be a simple matter to put up an A frame or pipe mast to use as a second support. (Also, tower owners see **Fig 30** inset.)

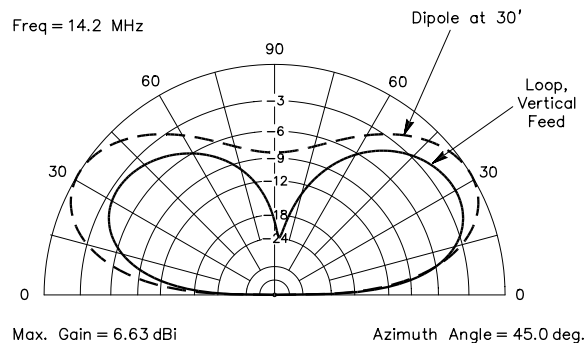
The overall length of the wire used in a loop is



**Fig 30**—Details of the full-wave loop. The dimensions given are for operation at 7.05 MHz. The height above ground was 7 feet in this instance, although improved performance should result if the builder can install the loop higher above ground without sacrificing length on the vertical sides. The inset illustrates how a single supporting structure can be used to hold the loop in a diamond-shaped configuration. Feeding the diamond at the lower tip provides radiation in the horizontal plane. Feeding the system at either side will result in vertical polarization of the radiated signal.



**Fig 31**—Elevation-plane responses for the 7-MHz loop, fed at different points. The solid line is for feeding it at the bottom; the dashed line is for feeding it at either corner at the bottom; the dotted line is for feeding it at the center of one of the vertical sides. For reference, the response of a simple flattop horizontal dipole at 30 feet in height is shown as a dashed-dotted line.



**Fig 32**—Elevation-plane response of 7-MHz loop used on 14.2 MHz. This is for a feed point at the center of one of the two vertical wires. The dashed line is the response of a flattop 20-meter dipole at 30 feet in height for comparison.

determined in feet from the formula  $1005/f$  (MHz). Hence, for operation at 7.125 MHz the overall wire length will be 141 feet. The matching transformer, an electrical  $1/4 \lambda$  of 75- $\Omega$  coax cable, can be computed by dividing 246 by the operating frequency in MHz, then multiplying that number by the velocity factor of the cable being used. Thus, for operation at 7.125 MHz,  $246/7.125 \text{ MHz} = 34.53$  feet. If coax with solid polyethylene insulation is used, a velocity factor of 0.66 must be employed. Foam-polyethylene coax has a velocity factor of 0.80. Assuming RG-59 is used, the

length of the matching transformer becomes  $34.53 \text{ (feet)} \times 0.66 = 22.79$  feet, or 22 feet,  $9\frac{1}{2}$  inches.

This same loop antenna may be used on the 14 and 21-MHz bands, although its pattern will not be as good as that on its fundamental frequency. The gain from a simple flattop dipole, mounted at 30 feet, will be superior to the loop operated on a harmonic frequency. Fig 32 shows the response at the peak lobe of the loop, at a  $45^\circ$  angle to the plane of the loop, compared to the peak response for a simple halfwave 20-meter dipole, 30 feet high.

## A Receiving Loop for 1.8 MHz

You can use a small shielded loop antennas to improve reception under certain conditions, especially at the lower amateur frequencies. This is particularly true when high levels of man-made noise are prevalent, when the second-harmonic energy from a nearby broadcast station falls in the 1.8-MHz band, or when interference exists from some other amateur station in the immediate area. A properly constructed and tuned small loop will exhibit approximately 30 dB of front-to-side response, the minimum response being at right angles to the plane of the loop. Therefore, noise and interference can be reduced significantly or completely nulled out, by rotating the

loop so that it is sideways to the interference-causing source.

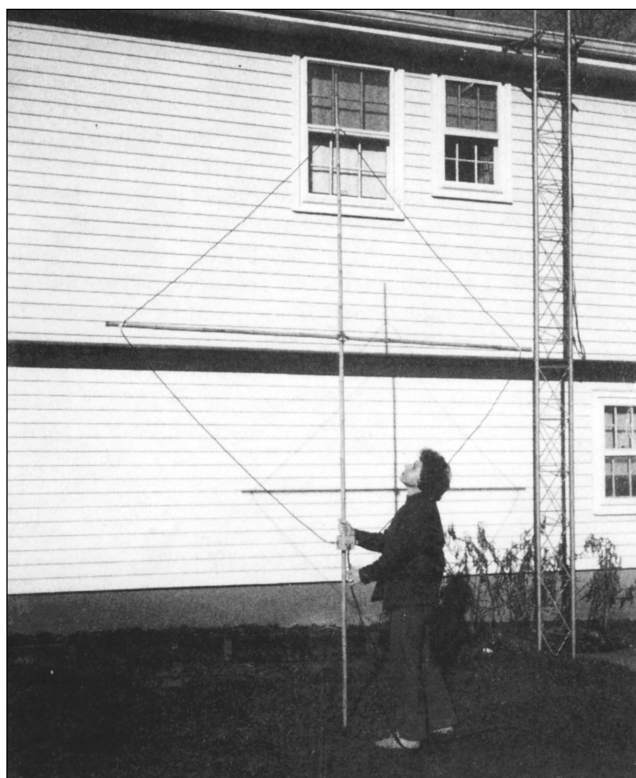
Generally speaking, small shielded loops are far less responsive to man-made noise than are the larger antennas used for transmitting and receiving. But a trade-off in performance must be accepted when using the loop, for the strength of received signals will be 10 or 15 dB less than when using a full-size resonant antenna. This condition is not a handicap on 1.8 or 3.5 MHz, provided the station receiver has normal sensitivity and overall gain. Because a front-to-side ratio of 30 dB may be expected, a shielded loop can be used to eliminate a variety of receiving problems if made rotatable, as shown in Fig 33.

To obtain the sharp bidirectional pattern of a small loop, the overall length of the conductor must not exceed  $0.1 \lambda$ . The loop of Fig 34 has a conductor length of 20 feet. At 1.81 MHz, 20 feet is  $0.037 \lambda$ . With this style of loop,  $0.037 \lambda$  is about the maximum practical dimension if you want to tune the element to resonance. This limitation results from the distributed capacitance between the shield and inner conductor of the loop. RG-59 was used for the loop element in this example. The capacitance per foot for this cable is 21 pF, resulting in a total distributed capacitance of 420 pF. An additional 100 pF was needed to resonate the loop at 1.810 MHz.

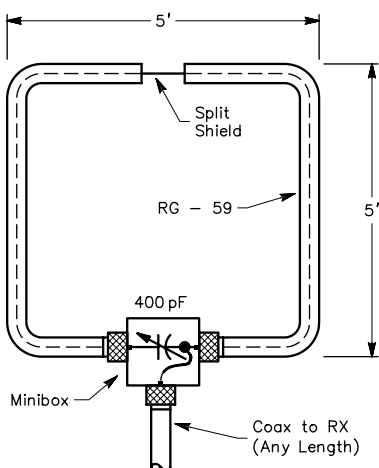
Therefore, the approximate inductance of the loop is  $15 \mu\text{H}$ . The effect of the capacitance becomes less pronounced at the higher end of the HF spectrum, provided the same percentage of a wavelength is used in computing the conductor length. The ratio between the distributed capacitance and the lumped capacitance used at the feed point becomes greater at resonance. These facts should be contemplated when scaling the loop to those bands above 1.8 MHz.

There will not be a major difference in the construction requirements of the loop if coaxial cables other than RG-59 are used. The line impedance is not significant with respect to the loop element. Various types of coaxial line exhibit different amounts of capacitance per foot, however, thereby requiring more or less capacitance across the feed point to establish resonance.

Shielded loops are not affected noticeably by nearby



**Fig 33—Jean DeMaw, W1CKK, tests the 1.8-MHz shielded loop. Bamboo cross arms are used to support the antenna.**



**Fig 34—Schematic diagram of the loop antenna. The dimensions are not critical provided overall length of the loop element does not exceed approximately  $0.1 \lambda$ . Small loops which are one half or less the size of this one will prove useful where limited space is a consideration.**

objects, and therefore they can be installed indoors or out after being tuned to resonance. Moving them from one place to another does not significantly affect the tuning.

You can see in the model shown in Fig 33 that a supporting structure was fashioned from bamboo poles. The X frame is held together at the center with two U bolts. The loop element is taped to the cross-arms to form a square. You could likely use metal cross arms without seriously degrading the antenna performance. Alternatively, wood can be used for the supporting frame.

A Minibox was used at the feed point of the loop to hold the resonating variable capacitor. In this model a 50 to 400-pF compression trimmer was used to establish resonance. You must weatherproof the box for outdoor installations.

Remove the shield braid of the loop coax for one inch directly opposite the feed point. You should treat the exposed areas with a sealing compound once this is done.

In operation this receiving loop has proven very effective for nulling out second-harmonic energy from local broadcast stations. During DX and contest operations on 1.8 MHz it helped prevent receiver overloading from nearby 1.8-MHz stations that share the band. The marked reduction in response to noise has made the loop a valuable station accessory when receiving weak signals. It is not used all of the time, but is available when needed by connecting it to the receiver through an antenna selector switch. Reception of European stations with the loop has been possible from New England at times when other antennas were totally ineffective because of noise.

It was also discovered that the effects of approaching storms (with attendant atmospheric noise) could be nullified considerably by rotating the loop away from the storm front.

It should be said that the loop does not exhibit meaningful directivity when receiving sky-wave signals. The directivity characteristics relate primarily to ground-wave signals. This is a bonus feature in disguise, for when nulling out local noise or interference, one is still able to copy sky-wave signals from all compass points!

For receiving applications it is not necessary to match the feed line to the loop, though doing so may enhance the performance somewhat. If no attempt is made to obtain an SWR of 1, the builder can use 50 or 75- $\Omega$  coax for a feeder, and no difference in performance will be observed. The Q of this loop is sufficiently low to allow the operator to peak it for resonance at 1.9 MHz and use it across the entire 1.8-MHz band. The degradation in performance at 1.8 and 2 MHz will be so slight that it will be difficult to discern.

## BIBLIOGRAPHY

Source material and more extended discussion of topics covered in this chapter can be found in the references given below and in the textbooks listed at the end of Chapter 2.

- C. F. W. Anderson, "A Crossed-Loop/Goniometer DF Antenna for 160 Meters," *The ARRL Antenna Compendium Vol 1* (Newington: ARRL, 1985), pp 127-132.
- J. S. Belrose, "Ferromagnetic Loop Aerials," *Wireless Engineer*, Feb 1955, pp 41-46.
- J. S. Belrose, "An Update on Compact Transmitting Loops," *QST*, Nov 1993, pp 37-40.
- J. S. Belrose, "Loops for 80-Meter DX," *QEX*, Aug 1997, pp 3-16.
- D. S. Bond, *Radio Direction Finders*, 1st ed. (New York: McGraw-Hill Book Co, 1944).
- G. Bramslev, "Loop Aerial Reception," *Wireless World*, Nov 1952, pp 469-472.
- G. Breed, "The K9AY Terminated Loop—A Compact, Directional Receiving Antenna," *QST*, Sep 1997, pp 43-46.
- G. Brown, "The Principles of HF Radio Direction Finding Loops," *QEX*, Sep 1995, pp 19-23.
- R. W. Burhans, "Experimental Loop Antennas for 60 kHz to 200 kHz," *Technical Memorandum (NASA) 71* (Athens, OH: Ohio Univ, Dept of Electrical Engr), Dec 1979.
- R. W. Burhans, "Loop Antennas for VLF-LF," *Radio-Electronics*, Jun 1983, pp 83-87.
- R. Capon, "A Compact Loop for 30 through 12 Meters," *QST*, May 1994, pp 33-36.
- D. J. Crockett, "A Triband 75/40/30-Meter Delta Loop," *The ARRL Antenna Compendium Volume 5* (Newington, CT: ARRL, 1996).
- D. DeMaw, "Beat the Noise with a Scoop Loop," *QST*, Jul 1977, pp 30-34.
- D. DeMaw, *Ferromagnetic-Core Design and Application Handbook* (Englewood Cliffs, NJ: Prentice-Hall Inc, 1981).
- D. DeMaw and L. Aurick, "The Full-Wave Delta Loop at Low Height," *QST*, Oct 1984, pp 24-26.
- D. DeMaw, "Transmitting Loops Revisited," *QST*, Mar 1988, pp 27-29.

- D. DeMaw, "A Closer Look at Horizontal Loop Antennas," *QST*, May 1990, pp 28-29,35.
- R. Devore and P. Bohley, "The Electrically Small Magnetically Loaded Multiturn Loop Antenna," *IEEE Trans on Ant and Prop*, Jul 1977, pp 496-505.
- T. Dorbuck, "Radio Direction-Finding Techniques," *QST*, Aug 1975, pp 30-36.
- R. G. Fenwick, "A Loop Array for 160 Meters," *CQ*, Apr 1986, pp 25-29.
- D. Fischer, "The Loop Skywire," *QST*, Nov 1985, pp 20-22. Also "Feedback," *QST*, Dec 1985, p 53.
- R. A. Genaille, "V.L.F. Loop Antenna," *Electronics World*, Jan 1963, pp 49-52.
- G. Gercke, "Radio Direction/Range Finder," *73*, Dec 1971, pp 29-30.
- R. S. Glasgow, *Principles of Radio Engineering* (New York: McGraw-Hill Book Co, Inc, 1936).
- S. Goldman, "A Shielded Loop for Low Noise Broadcast Reception," *Electronics*, Oct 1938, pp 20-22.
- F. W. Grover, *Inductance Calculation-Working Formulas and Tables* (New York: D. VanNostrand Co, Inc, 1946).
- J. V. Hagan, "A Large Aperture Ferrite Core Loop Antenna for Long and Medium Wave Reception," *Loop Antennas Design and Theory*, M.G. Knitter, Ed. (Cambridge, WI: National Radio Club, 1983), pp 37-49.
- T. Hart, "Small, High-Efficiency Loop Antennas," *QST*, Jun 1986, pp 33-36.
- T. Hart, *Small High Efficiency Antennas Alias The Loop* (Melbourne, FL: W5QJR Antenna Products, 1985)
- H. Hawkins, "A Low Budget, Rotatable 17 Meter Loop," *QST*, Nov 1997, p 35.
- F. M. Howes and F. M. Wood, "Note on the Bearing Error and Sensitivity of a Loop Antenna in an Abnormally Polarized Field," *Proc IRE*, Apr 1944, pp 231-233.
- B. Jones, KD7S, "You Can Build: A Compact Loop Antenna for 30 Through 12 Meters," Nov 1994 *QST*, pp 33-36.
- J. A. Lambert, "A Directional Active Loop Receiving Antenna System," *Radio Communication*, Nov 1982, pp 944-949.
- D. Lankford, "Loop Antennas, Theory and Practice," *Loop Antennas Design and Theory*, M. G. Knitter, Ed. (Cambridge, WI: National Radio Club, 1983), pp 10-22.
- D. Lankford, "Multi-Rod Ferrite Loop Antennas," *Loop Antennas Design and Theory*, M. G. Knitter, Ed. (Cambridge, WI: National Radio Club, 1983), pp 53-56.
- G. Levy, "Loop Antennas for Aircraft," *Proc IRE*, Feb 1943, pp 56-66. Also see correction, *Proc IRE*, Jul 1943, p 384.
- J. Malone, "Can a 7 foot 40m Antenna Work?" *73*, Mar 1975, pp 33-38.
- R. Q. Marris, "An In-Room 80-Meter Transmitting Multiturn Loop Antenna," *QST*, Feb 1996, pp 43-45. Feedback. *QST*, May 1996, p 48.
- L. G. McCoy, "The Army Loop in Ham Communications," *QST*, Mar 1968, pp 17, 18, 150, 152. (See also Technical Correspondence, *QST*, May 1968, pp 49-51 and Nov 1968, pp 46-47.)
- R. G. Medhurst, "HF Resistance and Self Capacitance of Single Layer Solenoids," *Wireless Engineer*, Feb 1947, pp 35-43, and Mar 1947, pp 80-92.
- D. Monticelli, "Build the Versa-Loop," *QST*, Aug 1989, pp 22-26.
- G. P. Nelson, "The NRC FET Altazimuth Loop Antenna," *N.R.C. Antenna Reference Manual Vol. 1*, 4th ed., R. J. Edmunds, Ed. (Cambridge, WI: National Radio Club, 1982), pp 2-18.
- R. Newkirk, "Honey, I Shrunk the Antenna!" *QST*, Jul 1993, pp 34-35,39.
- P. Newton, "The Droopy Loop," *QST*, Jul 1996, pp 57-58.
- K. H. Patterson, "Down-To-Earth Army Antenna," *Electronics*, Aug 21, 1967, pp 111-114.
- R. C. Pettengill, H. T. Garland and J. D. Meindl, "Receiving Antenna Design for Miniature Receivers," *IEEE Trans on Ant and Prop*, Jul 1977, pp 528-530.
- R. Z. Plasencia, W0RPV, "Remotely Controlled Antenna Coupler," *The ARRL Antenna Compendium Vol 2* (Newington: ARRL, 1989), pp 182-186.
- W. J. Polydoroff, *High Frequency Magnetic Materials—Their Characteristics and Principal Applications* (New York: John Wiley and Sons, Inc, 1960).
- E. Robberson, "QRM? Get Looped," *Radio and Television News*, Aug 1955, pp 52-54, 126.
- G. S. Smith, "Radiation Efficiency of Electrically Small Multiturn Loop Antennas," *IEEE Trans on Ant and Prop*, Sep 1972, pp 656-657.
- E. C. Snelling, *Soft Ferrites—Properties and Applications* (Cleveland, OH: CRC Press, 1969).
- G. Thomas, "The Hot Rod—An Inexpensive Ferrite Booster Antenna," *Loop Antennas Theory and Design*, M. G. Knitter, Ed. (Cambridge, WI: National Radio Club, 1983), pp 57-62.
- J. R. True, "Low-Frequency Loop Antennas," *Ham Radio*, Dec 1976, pp 18-24.
- O. G. Villard, "The Coplanar Twin Loop Antenna," *QST*, Sep 1988, pp 29-35.
- E. G. VonWald, "Small-Loop Antennas," *Ham Radio*, May 1972, pp 36-41.
- "An FET Loop Amplifier with Coaxial Output," *N.R.C. Antenna Reference Manual, Vol 2*, 1st ed., R. J. Edmunds, Ed. (Cambridge, WI: National Radio Club, Oct 1982), pp 17-20.
- Aperiodic Loop Antenna Arrays* (Hermes Electronics Ltd, Nov 1973).
- Reference Data for Radio Engineers*, 6th ed. (Indianapolis: Howard W. Sams & Co, subsidiary of ITT, 1977).

## Chapter 6

# Low-Frequency Antennas

In theory there is no difference between antennas at 10 MHz and up and those for lower frequencies. In reality however, there are often important differences. It is the size of the antennas, which increases as frequency is decreased, that creates practical limits on what can be realized physically at reasonable cost.

At 7.3 MHz,  $1 \lambda = 133$  feet and by the time we get to 1.8 MHz,  $1 \lambda = 547$  feet. Even a  $\lambda/2$  dipole is very long on 160 meters. The result is that the average antenna for these

bands is quite different from the higher bands, where Yagis and other relatively complex antennas dominate. In addition, vertical antennas can be more useful at low frequencies than they are on 20 meters and above because of the low heights (in wavelengths) usually available for horizontal antennas on the low bands. Much of the effort on the low bands is focused on how to build simple but effective antennas with limited resources. This section is devoted to antennas for use on amateur bands between 1.8 to 7 MHz.

## Horizontal Antennas

As shown in [Chapter 3](#), radiation angles from horizontal antennas are a very strong function of the height above ground in wavelengths. Typically for DX work heights of  $\lambda/2$  to  $1 \lambda$  are considered to be a minimum. As we go down in frequency these heights become harder to realize. For example, a 160-meter dipole at 70 feet is only  $0.14 \lambda$  high. This antenna will be very effective for local and short distance QSOs but not very good for DX work. Despite this limitation, horizontal antennas are very popular on the lower bands because the low frequencies are often used for short range communications, local nets and rag chewing. Also horizontal antennas do not require extensive ground systems to be efficient.

### DIPOLE ANTENNAS

Half-wave dipoles and variations of these can be a very good choice for a low band antenna. A variety of possibilities are shown in [Fig 1](#). An untuned or “flat” feed line is a logical choice on any band because the losses are low, but this generally limits the use of the antenna to one band. Where only single-band operation is wanted, the  $\lambda/2$  antenna fed with untuned line is one of the most popular systems on the 3.5 and 7-MHz bands.

If the antenna is a single-wire affair, its impedance is in the vicinity of  $60 \Omega$ , depending on the height and the ground characteristics. The most common way to feed the antenna is with  $72\text{-}\Omega$  twin-lead or  $50$  or  $75\text{-}\Omega$  coaxial line. Heavy duty twin-lead and coaxial line present support

problems because they are a concentrated weight at the center of the antenna, tending to pull the center of the antenna down. This can be overcome by using an auxiliary pole to take at least some of the weight of the line. The line should come away from the antenna at right angles, and it can be of any length.

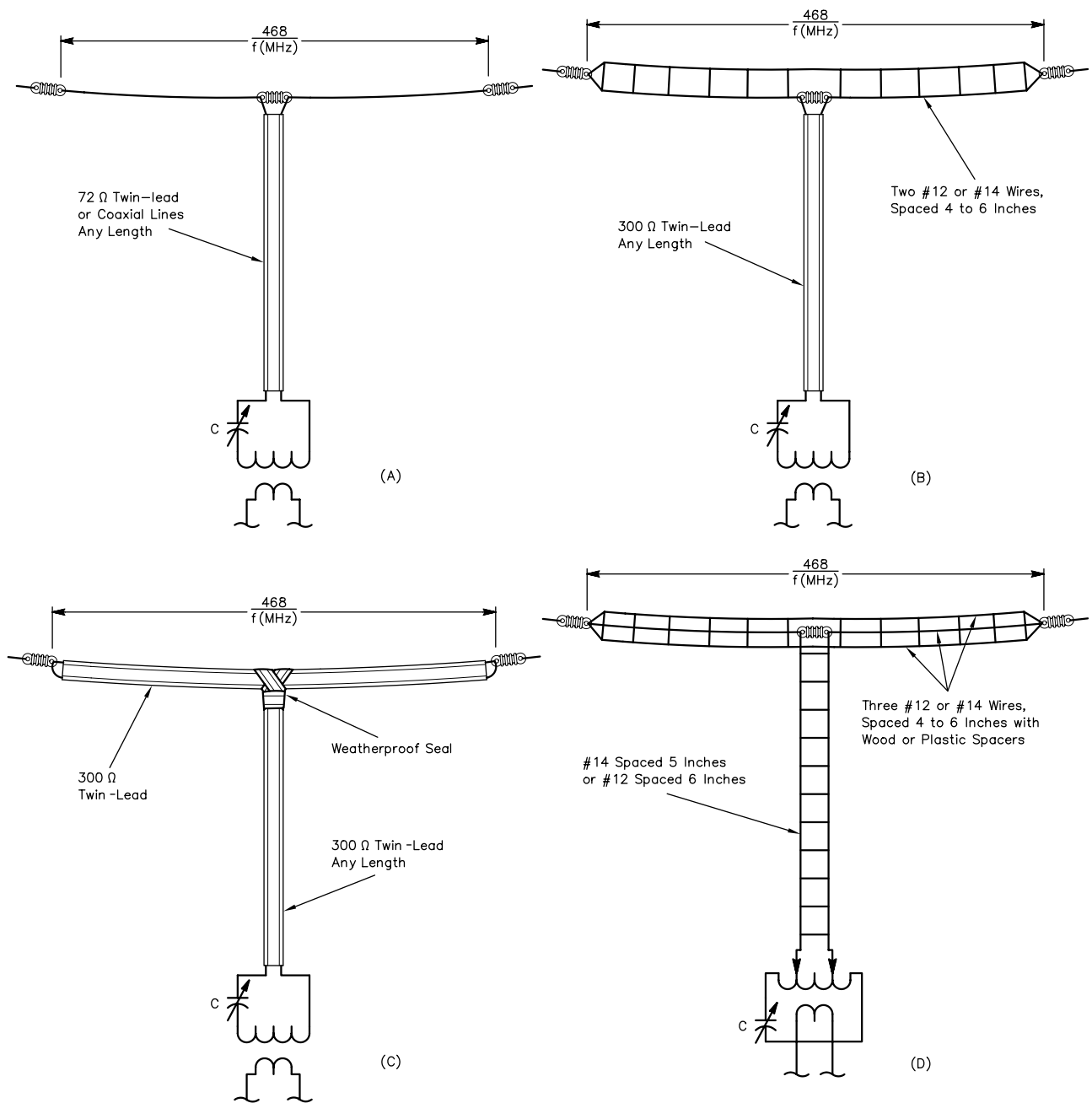
### Folded Dipoles

A folded dipole ([Fig 1B](#) and C) has an impedance of about  $300 \Omega$ , and can be fed directly with any length of  $300\text{-}\Omega$  line. The folded dipole can be made of ordinary wire spaced by lightweight wooden or plastic spacers, 4 or 6 inches long, or a piece of  $300$  or  $450\text{-}\Omega$  twin-lead or ladder line.

A folded dipole can be fed with a  $600\text{-}\Omega$  open wire line with only a 2:1 SWR, but a nearly perfect match can be obtained with a three-wire dipole fed with either  $450\text{-}\Omega$  ladder line or  $600\text{-}\Omega$  open wire line. One advantage of the two- and three-wire antennas over the single wire is that they offer a better match over a wider band. This is particularly important if full coverage of the 3.5-MHz band is contemplated.

### Inverted-V Dipole

The halves of a dipole may be sloped to form an inverted V, as shown in [Fig 2](#). This has the advantages of requiring only a single high support and less horizontal space. There will be some difference in performance between a normal horizontal dipole and the inverted V as shown by

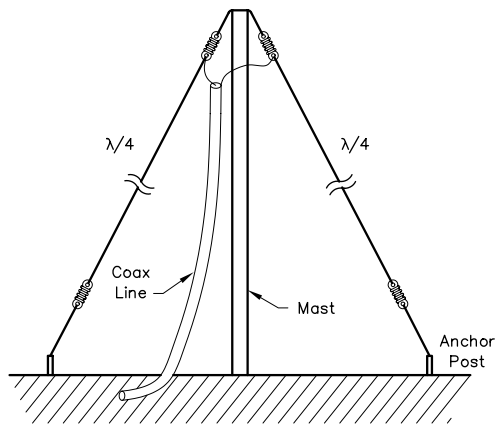


**Fig 1—Half-wavelength antennas for single band operation. The multiwire types shown in B, C and D offer a better match to the feeder over a somewhat wider range of frequencies but otherwise the performances are identical. The feeder should run away from the antenna at a right angle for as great a distance as possible. In the coupling circuits shown, tuned circuits should resonate to the operating frequency. In the series-tuned circuits of A, B, and C, high L and low C are recommended, and in D the inductance and capacitance should be similar to the output-amplifier tank, with the feeders tapped across at least  $\frac{1}{2}$  the coil. The tapped-coil matching circuit shown in [Chapter 25](#) can be substituted in each case.**

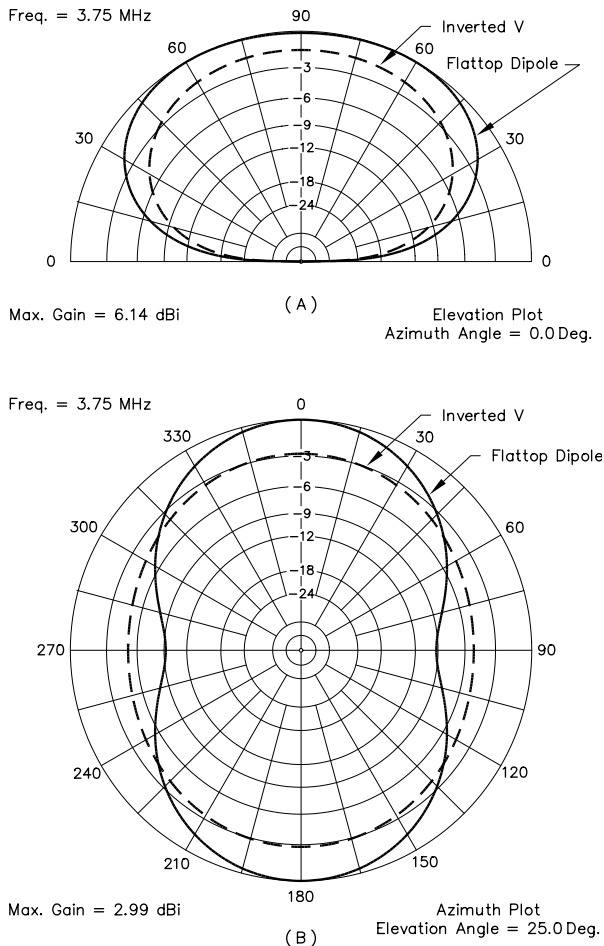
the radiation patterns in [Fig 3](#). There is small loss in peak gain and the pattern is less directional.

Sloping of the wires results in a lowering of the resonant frequency and a decrease in feed-point impedance and bandwidth. Thus, for the same frequency, the length of the dipole must be decreased somewhat. The angle at the apex

is not critical, although it should probably be made no smaller than  $90^\circ$ . Because of the lower impedance, a 50- $\Omega$  line should be used. For those who are dissatisfied with anything but a perfect match, the usual procedure is to adjust the angle for lowest SWR while keeping the dipole resonant by adjustment of length. Bandwidth may be increased by using



**Fig 2—The inverted-V dipole. The length and apex angle should be adjusted as described in the text.**

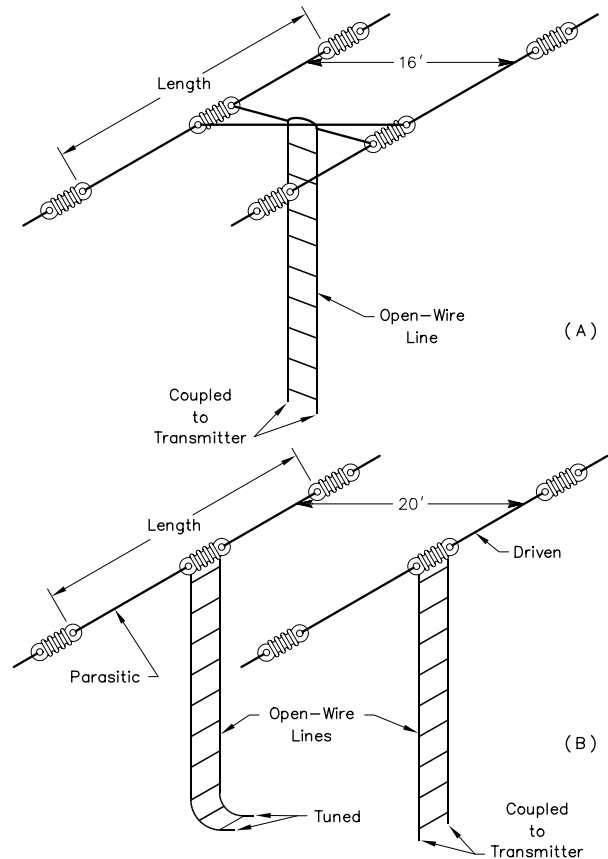


**Fig 3—At A, elevation and at B, azimuthal radiation patterns comparing a normal 80-meter dipole and an inverted-V dipole. The center of both dipoles is at 65 feet and the ends of the inverted V are at 20 feet. The frequency is 3.750 MHz.**

multiconductor elements, such as a cage configuration.

### PHASED HORIZONTAL ARRAYS

Phased arrays with horizontal elements, which provide some directional gain, can be used to advantage at 7 MHz, if they can be placed at least 40 feet above ground. At 3.5 MHz heights of 70 feet or more are needed for any real advantage. Many of the driven arrays discussed in Chapter 8 and even some of the Yagis discussed in Chapter 11 can be used as fixed directional antennas. If a bidirectional characteristic is desired, the W8JK array, shown in Fig 4A, is a good one. If a unidirectional characteristic is required, two elements can be mounted about 20 feet apart and provision included for tuning one of the elements as either a director or reflector, as shown in Fig 4B.



**Fig 4—Directional antennas for 7 MHz. To realize any advantage from these antennas, they should be at least 40 feet high. At A, system is bidirectional. At B, system is unidirectional in a direction depending upon the tuning conditions of the parasitic element. The length of the elements in either antenna should be exactly the same, but any length from 60 to 150 feet can be used. If the length of the antenna at A is between 60 and 80 feet, the antenna will be bidirectional along the same line on both 7 and 14 MHz. The system at B can be made to work on 7 and 14 MHz in the same way, by keeping the length between 60 and 80 feet.**

The parasitic element is tuned at the end of its feed line with a series or parallel-tuned circuit (whichever would normally be required to couple power into the line), and the proper tuning condition can be found by using the system for receiving and listening to distant stations along the line to the rear of the antenna. Tuning the feeder to the parasitic element can minimize the received signals from the back of the antenna. This is in effect adjusting the antenna for maximum front-to-back ratio. Maximum front-to-back does not occur at the same point as maximum forward gain but the loss in forward gain is very small. Adjusting the antenna for maximum forward gain (peaking received signals in the forward direction) may increase the forward gain slightly but will almost certainly result in relatively poor front-to-back ratio.

### A MODIFIED EXTENDED DOUBLE ZEPP

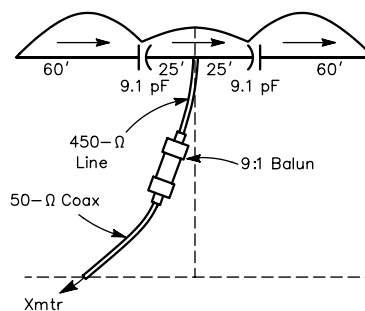
If the distance between the available supports is greater than  $\lambda/2$  then a very simple form of a single wire collinear array can be used to achieve significant gain. The *extended double Zepp* antenna has long been used by amateurs and is discussed in Chapter 8. A simple variation of this antenna with substantially improved bandwidth can be very useful on 3.5 and 7.0 MHz. The following material has been taken from an article by [Rudy Severns, N6LF](#), in *The ARRL Antenna Compendium Vol 4*.

The key to improving the characteristics of a standard double-extended Zepp is to modify the current distribution. One of the simplest ways to do this is to insert a reactance(s) in series with the wire. This could either be an inductor(s) or a capacitor(s). In general, a series capacitor will have a higher Q and therefore less loss. With either choice it is desirable to use as few components as possible.

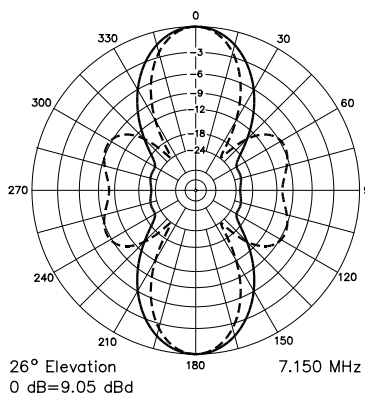
As an initial trial at 7 MHz, only two capacitors, one on each side of the antenna, were used. The value and position of the capacitors was varied to see what would happen. It quickly became clear that the reactance at the feed point could be tuned out by adjusting the capacitor value, making the antenna look essentially like a resistor over the entire band. The value of the feed-point resistance could be varied from less than 150  $\Omega$  to over 1500  $\Omega$  by changing the location of the capacitors and adjusting their values to resonate the antenna.

A number of interesting combinations were created. The one ultimately selected is shown in **Fig 5**. The antenna is 170 feet in length. Two 9.1 pF capacitors are located 25 feet out each side of the center. The antenna is fed with 450- $\Omega$  transmission line and a 9:1 three-core Guanella balun used at the transmitter to convert to 50  $\Omega$ . The transmission line can be any convenient length and it operates with a very low SWR.

That's all there is to it. The radiation pattern, overlaid with that for a standard DEZepp for comparison, is shown in **Fig 6**. The sidelobes are now reduced to below 20 dB. The main lobe is now 43° wide at the 3-dB points, as opposed to 35° for the original DEZepp. The antenna has gain over a



**Fig 5**—Schematic for modified N6LF Double Extended Zepp. Overall length is 170 feet, with 9.1 pF capacitors placed 25 feet each side of center.



**Fig 6**—Azimuth pattern for N6LF Double Extended Zepp (solid line), compared to classic Double Extended Zepp (dashed line). The main lobe for the modified antenna is slightly broader than that of the classic model, and the sidelobes are suppressed better.

dipole for  $> 50^\circ$  now and the gain of the main lobe has dropped only 0.2 dB below the original DEZepp.

### Experimental Results

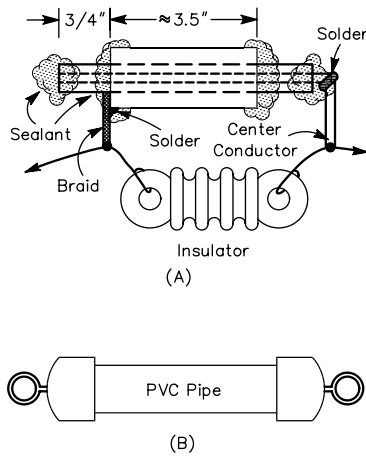
The antenna was made from #14 wire and the capacitors were made from 3.5-inch sections of RG-213, shown in **Fig 7A**. Note that great care should be taken to seal out moisture in these capacitors. The voltage across the capacitor for 1.5 kW will be about 2000 V so any corona will quickly destroy the capacitor.

A silicon sealant was used and then both ends covered with coax seal, finally wrapping it with plastic tape. The solder balls indicated on the drawing are to prevent wicking of moisture through the braid and the stranded center conductor. This is a small but important point if long service out in the weather is expected. An even better way to protect the capacitor would be to enclose it in a short piece of PVC pipe with end caps, as shown in **Fig 7B**.

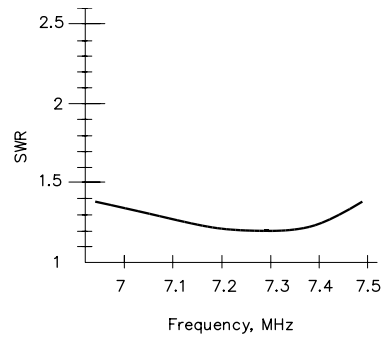
Note that all RG-8 type cables do not have exactly the same capacitance per foot and there will also be some end effect adding to the capacitance. If possible the capacitor should be trimmed with a capacitance meter. It isn't necessary to be too exact—the effect of varying the capacitance  $\pm 10\%$  was checked and the antenna still worked fine.

The results proved to be close to those predicted by the computer model. **Fig 8** shows the measured value for

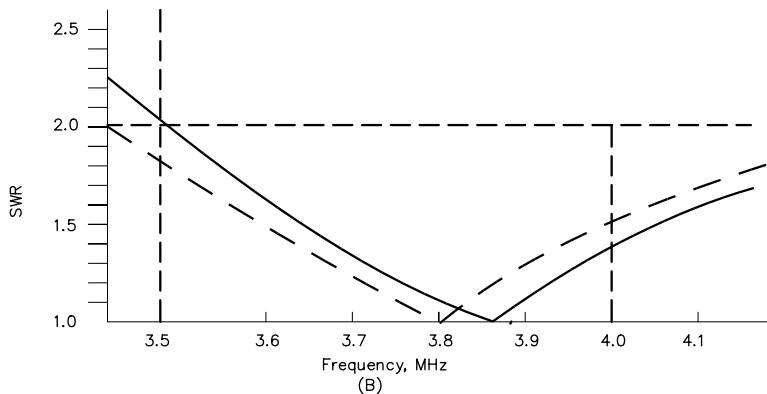
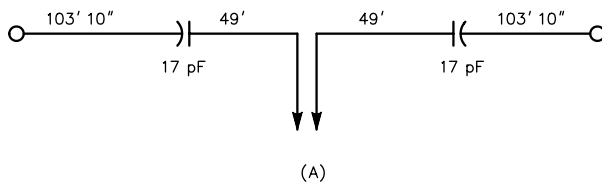




**Fig 7—**Construction details for series capacitor made from RG-213 coaxial cable. At A, the method used by N6LF is illustrated. At B, a suggested method to seal capacitor better against weather is shown, using a section of PVC pipe with end caps.



**Fig 8—**Measured SWR curve across 40-meter band for N6LF DEZepp.



**Fig 9—**75/80-meter modified Double Extended Zepp, designed using *NEC Wires*. At A, a schematic is shown for antenna. At B, SWR curve is shown across 75/80-meter band. Solid line shows measured curve for W7ISV antenna, which was pruned to place SWR minimum higher in the band. The dashed curve shows the computed response when SWR minimum is set to 3.8 MHz.

SWR across the band. These measurements were made with a Bird directional wattmeter. The worst SWR is 1.35:1 at the low end of the band.

Dick Ives, W7ISV, erected an 80-meter version of the antenna, shown in Fig 9A. The series capacitors are 17 pF. Since he isn't interested in CW, Dick adjusted the length for the lowest SWR at the high end of the band, as shown in

the SWR curve (Fig 9B). The antenna could have been tuned somewhat lower in frequency and would then provide an SWR < 2:1 over the entire band, as indicated by the dashed line.

This antenna provides wide bandwidth and moderate gain over the entire 75/80-meter band. Not many antennas will give you that with a simple wire structure.

# Vertical Antennas

On the low bands vertical antennas become increasingly attractive, especially for DX work, because they provide a means for lowering the radiation angle. This is especially true where practical heights for horizontal antennas are too low. In addition, verticals can be very simple and unobtrusive structures. For example, it is very easy to disguise a vertical as a flagpole. In fact an actual flagpole may be used as a vertical. Performance of a vertical is determined by several factors:

- Height of the vertical portion of the radiator
- The ground or counterpoise system efficiency
- Ground characteristics in the near and far-field regions
- The efficiency of loading elements and matching networks

For best performance the vertical portion of the antenna should be  $\lambda/4$  or more, but this is not an absolute requirement. With proper design, antennas as short as  $0.1 \lambda$  or even less can be efficient and effective. Antennas shorter than  $\lambda/4$  will be reactive and some form of loading and perhaps a matching network will be required.

If the radiator is made of wire supported by nonconducting material, the approximate length for  $\lambda/4$  resonance can be found from:

$$\ell_{\text{feet}} = \frac{234}{f_{\text{MHz}}} \quad (\text{Eq 1})$$

For tubing, the length for resonance must be shorter than given by the above equation, as the length-to-diameter ratio is lower than for wire (see [Chapter 2](#)). For a tower, the resonant length will be shorter still. In any case, after installation the antenna length (height) can be adjusted for resonance at the desired frequency.

The effect of ground characteristics on losses and elevation pattern is discussed in detail in [Chapter 3](#). The most important points made in that discussion are the effect of ground characteristics on the radiation pattern and the means for achieving low ground resistance in a buried ground system. As ground conductivity increases, low-angle radiation improves. This makes a vertical very attractive to those who live in areas with good ground conductivity. If your QTH is on a saltwater beach, then a vertical would be very effective, even when compared to horizontal antennas at great height.

When a buried-radial ground system is used, the efficiency of the antenna will be limited by the loss resistance of the ground system. The ground can be a number of radial wires extending out from the base of the antenna for about  $\lambda/4$ . Driven ground rods, while satisfactory for electrical safety and for lightning protection, are of little value as an RF ground for a vertical antenna, except perhaps in marshy or beach areas. As pointed out in [Chapter 3](#), many long radials are desirable. In general, however, a large number of short radials are preferable to only a few long radials, although the best system would have 60 or more radials

longer than  $\lambda/4$ . An elevated system of radials or a ground screen (*counterpoise*) may be used instead of buried radials, and can result in an efficient antenna.

## ELEVATED RADIALS AND COUNTERPOISES

*Elevated radials*, isolated from ground, can be used in place of an extensive buried radial system. Work by Al Christman, K3LC (ex-KB8I), has shown that 4 to 8 elevated radials can provide performance comparable to a 120  $\lambda/4$ -long buried wires. This is especially important for the low bands, where such a buried ground system is very large and impractical for most amateurs. An elevated ground system is sometimes referred to as a *ground plane* or *counterpoise*. [Fig 10](#) compares buried and elevated ground systems, showing the difference in current flow in the two systems.

An elevated ground can take several forms. A number of wires arranged with radial symmetry around the base of the antenna is shown in [Fig 10B](#). Four radials are normally used, but as few as two, or as many as eight, can be used. For a given height of vertical, the length of the radials can be adjusted to resonate the antenna. For a  $\lambda/4$  vertical, the radials are normally  $\lambda/4$  long.

In the case of a multiband vertical, two or more sets of radials, with different lengths, may be interleaved. The radials associated with each band are adjusted for resonance on their associated band.

A counterpoise is most commonly a system of elevated radials, where the radial wires are interconnected with jumpers, as shown in [Fig 11](#). As illustrated in [Fig 10](#), the purpose of the elevated-ground system is to provide a return path for the displacement currents flowing in the vicinity of the antenna. The idea is to minimize the current flowing through the ground itself, which is usually very lossy. By raising the radials above ground most of the current will flow in the radials, which are good conductors. This allows a simple radial system to provide a very efficient ground. However, there is a price to be paid for this.

The ground system now has a direct effect on the feed-point impedance, introducing reactance as well as resistance, and is relatively narrow band. For a given vertical height, the radial length must be adjusted to resonate the antenna. The length of the radials must be readjusted for each band if a multiband vertical is used. As pointed out above, this usually means the installation of a set of radials for each band. To minimize current flowing in the ground, the antenna, ground plane and feed line must be isolated from ground for RF. More on this later.

The height of the vertical does not have to be exactly  $\lambda/4$ . Other lengths may be used and the antenna may be resonated by adjusting the length of the radials. [Table 1](#) gives a comparison between three different vertical lengths in an antenna using four elevated radials at 3.525 MHz.

An important feature of [Table 1](#) is the dramatic reduction in radial length ( $L_2$ ) with even a small increase in

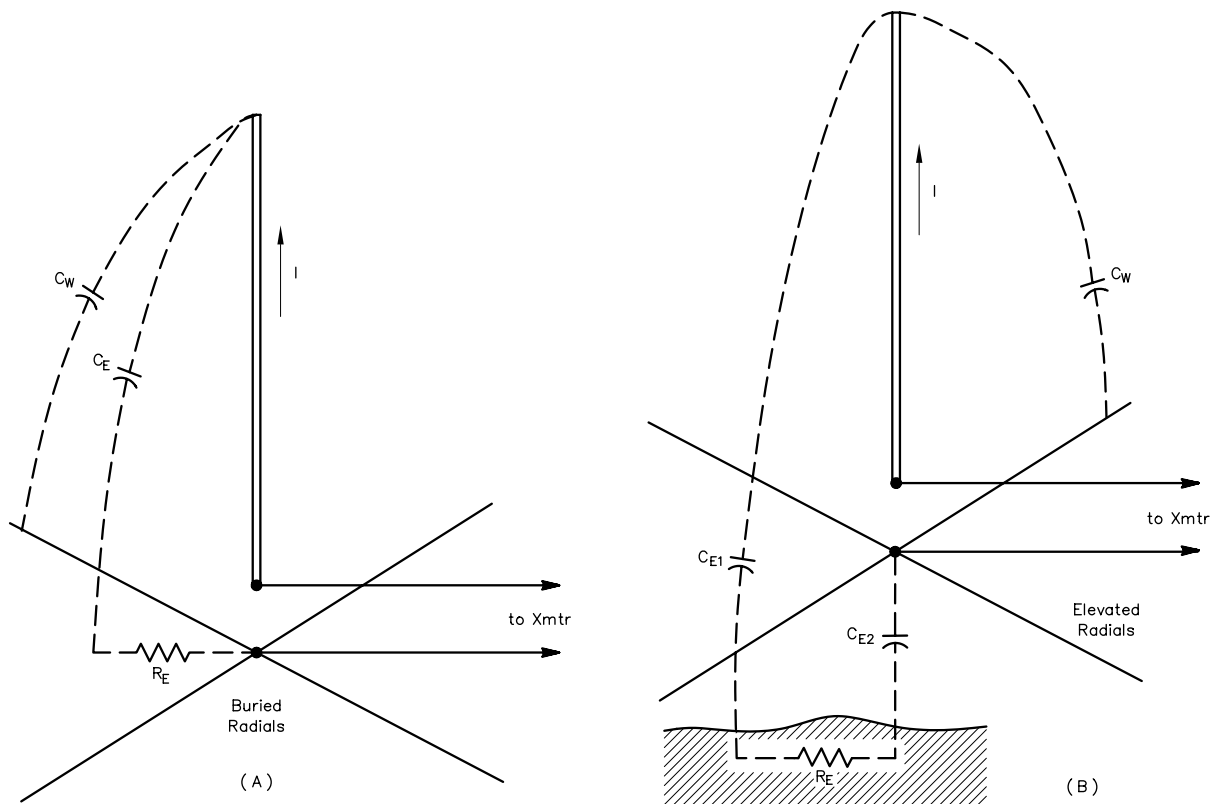


Fig 10—How earth currents affect the losses in a short vertical antenna system. At A, the current through the combination of  $C_E$  and  $R_E$  may be appreciable if  $C_E$  is much greater than  $C_W$ , the capacitance of the vertical to the ground wires. This ratio can be improved (up to a point) by using more radials. By raising the entire antenna system off the ground,  $C_E$  (which consists of the series combination of  $C_{E1}$  and  $C_{E2}$ ) is decreased while  $C_W$  stays the same. The radial system shown at B is sometimes called a *counterpoise*.

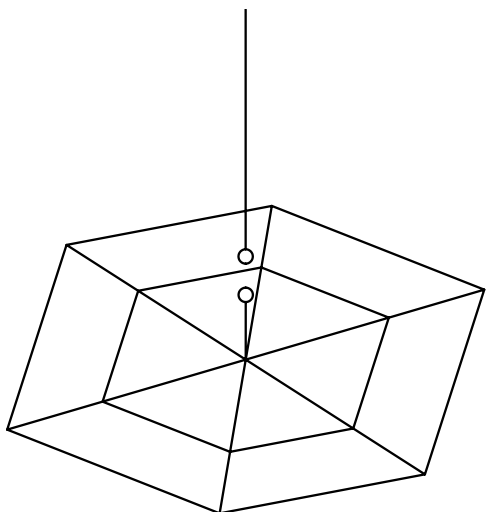


Fig 11—Counterpoise, showing the radial wires connected together by cross wires. The length of the perimeter of the individual meshes should be  $< \lambda/4$  to prevent undesired resonances. Sometimes the center portion of the counterpoise is made from wire mesh.

Table 1

Illustration of the Effect of Variable Vertical Height ( $L_1$ ) on Elevated Radial Length ( $L_2$ ) and  $R_R$

#12 Wire, Elevated 5 Feet Over Average Ground at 3.525 MHz

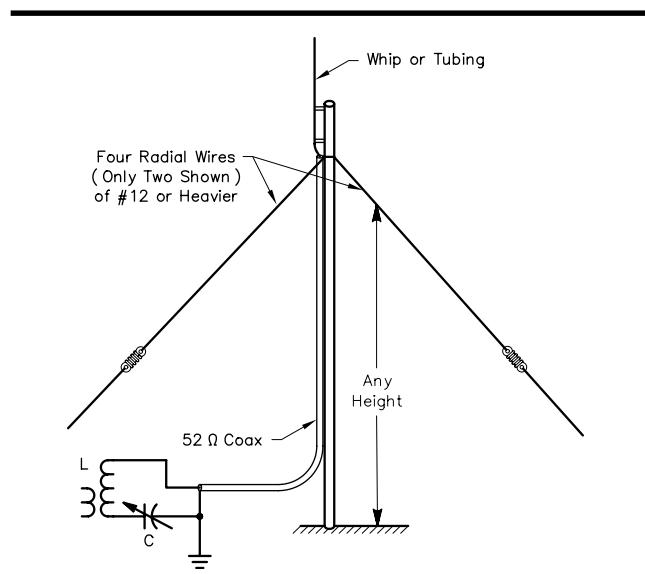
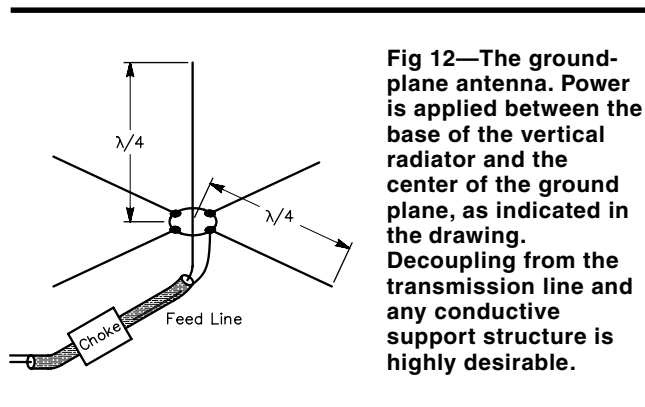
$L_1$ $\lambda$	$L_1$ (feet)	$L_2$ (feet)	$R_R$ ( $\Omega$ )
0.225	62.8	94	28.8
0.25	69.8	67	38.4
0.27	75.0	45	51.0
0.3	83.7	24	75.9

vertical height ( $L_1$ ). For example, increasing the height by 5 feet reduces the radial length by 22 feet. On the other hand even a small decrease in  $L_1$  can cause a substantial increase in  $L_2$ . This would be very undesirable, since the area required by the radials is already considerable. Notice also that the small increase in height raises  $R_R$  to 51  $\Omega$ . This trick of increasing the height slightly to reduce the size of the elevated ground system and to increase the input resistance can be very useful. In a following section the use of *top loading* for short antennas will be discussed. Top loading

can also be used on a  $\lambda/4$  vertical to achieve the same effect as increasing the height—the ability to use shorter radials and a better match.

### GROUND-PLANE ANTENNAS

The ground-plane antenna is a  $\lambda/4$  vertical with four radials, as shown in Fig 12. The entire antenna is elevated above ground with the radials angled downward. A practical example of a 7-MHz ground-plane antenna is given in Fig 13. As explained earlier, elevating the antenna reduces the ground loss and lowers the radiation angle somewhat.

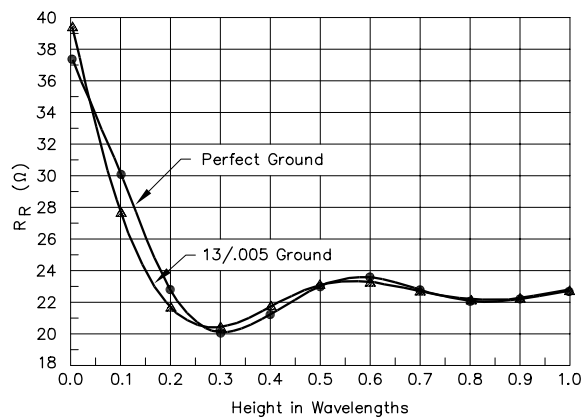


**Fig 13—A ground-plane antenna is effective for DX work on 7 MHz. Although its base can be any height above ground, losses in the ground underneath will be reduced by keeping the bottom of the antenna and the ground plane as high above ground as possible. Feeding the antenna directly with 50-Ω coaxial cable will result in a low SWR. The vertical radiator and the radials are all  $\lambda/4$  long electrically. Contrary to popular myth, the radials need not necessarily be 5% longer than the radiator. Their physical length will depend on their length-to-diameter ratios, the height over ground and the length of the vertical radiator, as discussed in text.**

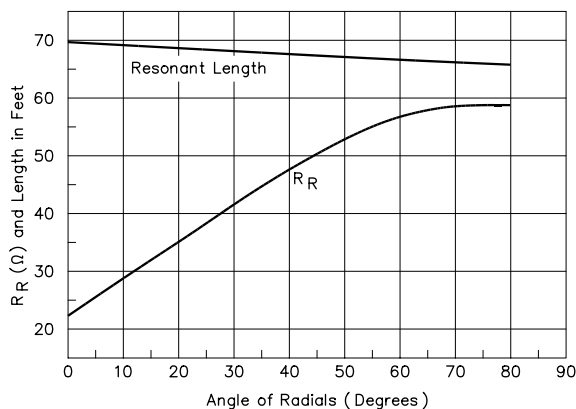
The radials are sloped downward to make the feed-point impedance closer to 50 Ω.

The feed-point impedance of the antenna varies with the height above ground, and to a lesser extent varies with the ground characteristics. Fig 14 is a graph of feed-point resistance ( $R_R$ ) for a ground-plane antenna with the radials parallel to the ground.  $R_R$  is plotted as a function of height above ground. Notice that the difference between perfect ground and average ground ( $\epsilon = 13$  and  $\sigma = 0.005$  S/m) is small, except when quite close to ground. Near ground  $R_R$  is between 36 and 40 Ω. This is a reasonable match for 50-Ω feed line but as the antenna is raised above ground  $R_R$  drops to approximately 22 Ω, which is not a very good match. The feed-point resistance can be increased by sloping the radials downward, away from the vertical section.

The effect of sloping the radials is shown in Fig 15.



**Fig 14—Radiation resistance of a 4-radial ground-plane antenna as a function of height over ground. Perfect and average ground are shown. Frequency is 3.525 MHz. Radial angle ( $\theta$ ) is 0°.**

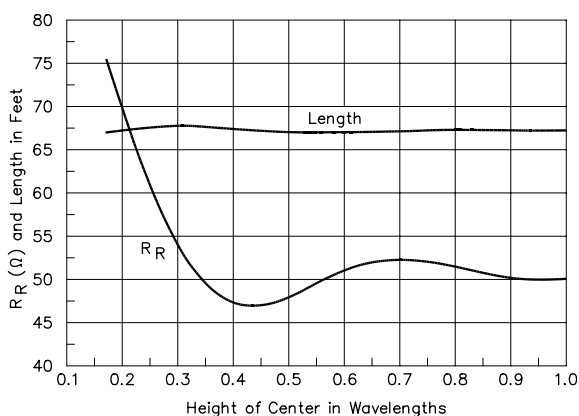


**Fig 15—Radiation resistance and resonant length for a 4-radial ground-plane antenna  $> 0.3 \lambda$  above ground as a function of radial droop angle ( $\theta$ ).**

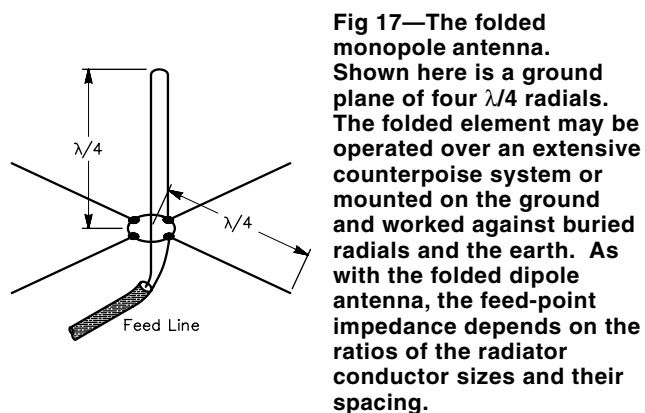
The graph is for an antenna well above ground ( $> 0.3 \lambda$ ). Notice that  $R_R = 50 \Omega$  when the radials are sloped downward at an angle of  $45^\circ$ . The resonant length of the antenna will vary slightly with the angle. In addition, the resonant length will vary a small amount with height above the ground. It is for these reasons, as well as the effect of conductor diameter, that some adjustment of the radial lengths is usually required. When the ground-plane antenna is used on the higher HF bands and at VHF, the height above ground is usually such that a radial sloping angle of  $45^\circ$  will give a good match to  $50\text{-}\Omega$  feed line.

The effect of height on  $R_R$  with a radial angle of  $45^\circ$  is shown in **Fig 16**. At 7 MHz and lower, it is seldom possible to elevate the antenna a significant portion of a wavelength and the radial angle required to match to  $50\text{-}\Omega$  line is usually of the order of  $10^\circ$  to  $20^\circ$ . To make the vertical portion of the antenna as long as possible, it may be better to accept a slightly poorer match and keep the radials parallel to ground.

The principles of the folded dipole (**Fig 1**) can also be applied to the ground-plane antenna, as shown in **Fig 17**.



**Fig 16**—Radiation resistance and resonant length for a 4-radial ground-plane antenna for various heights above average ground for radial droop angle  $\theta = 45^\circ$ .



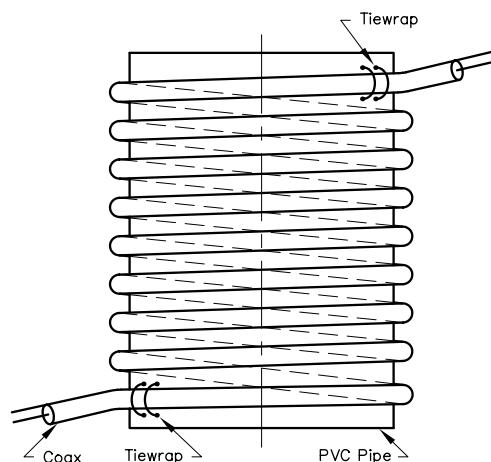
**Fig 17**—The folded monopole antenna. Shown here is a ground plane of four  $\lambda/4$  radials. The folded element may be operated over an extensive counterpoise system or mounted on the ground and worked against buried radials and the earth. As with the folded dipole antenna, the feed-point impedance depends on the ratios of the radiator conductor sizes and their spacing.

This is the *folded monopole* antenna. The feed-point resistance can be controlled by the number of parallel vertical conductors and the ratios of their diameters.

As mentioned earlier, it is important in most installations to isolate the antenna from the feed line and any conductive supporting structure. This is done to minimize the return current conducted through the ground. A return current on the feed line or the support structure can drastically alter the radiation pattern, usually for the worse. For these reasons, a balun (see **Chapter 26**) or other isolation scheme must be used. 1:1 baluns are effective for the higher bands but at 3.5 and 1.8 MHz commercial baluns often have too low a shunt inductance to provide adequate isolation. It is very easy to recognize when the isolation is inadequate. When the antenna is being adjusted by means of an isolated impedance or SWR meter, adjustments may be sensitive to your touching the instrument. After adjustment and after the feed line is attached, the SWR may be drastically different. When the feed line is inadequately isolated, the apparent resonant frequency or the length of the radials required for resonance may also be significantly different from what you expect.

In general, an isolation choke inductance of 50 to  $100 \mu\text{H}$  will be needed for 3.5 and 1.8-MHz ground-plane antennas. One of the easiest ways to make the required isolation choke is to wind a length of coaxial cable into a coil as shown in **Fig 18**. For 1.8 MHz, 30 turns of RG-213 wound on a 14-inch length of 8-inch diameter PVC pipe, will make a very good isolation choke that can handle full legal power continuously. A smaller choke could be wound on 4-inch diameter plastic drain pipe using RG-8X or a Teflon insulated cable. The important point here is to isolate or decouple the antenna from the feed line and support structure.

A full-size ground-plane antenna is often a little impractical for 3.5-MHz and quite impractical for 1.8 MHz,



**Fig 18**—A choke balun with sufficient impedance to isolate the antenna properly can be made by winding coaxial cable around a section of plastic pipe. Suitable dimensions are given in the text.

but it can be used at 7 MHz to good advantage, particularly for DX work. Smaller versions can be very useful on 3.5 and 1.8 MHz.

### EXAMPLES OF VERTICALS

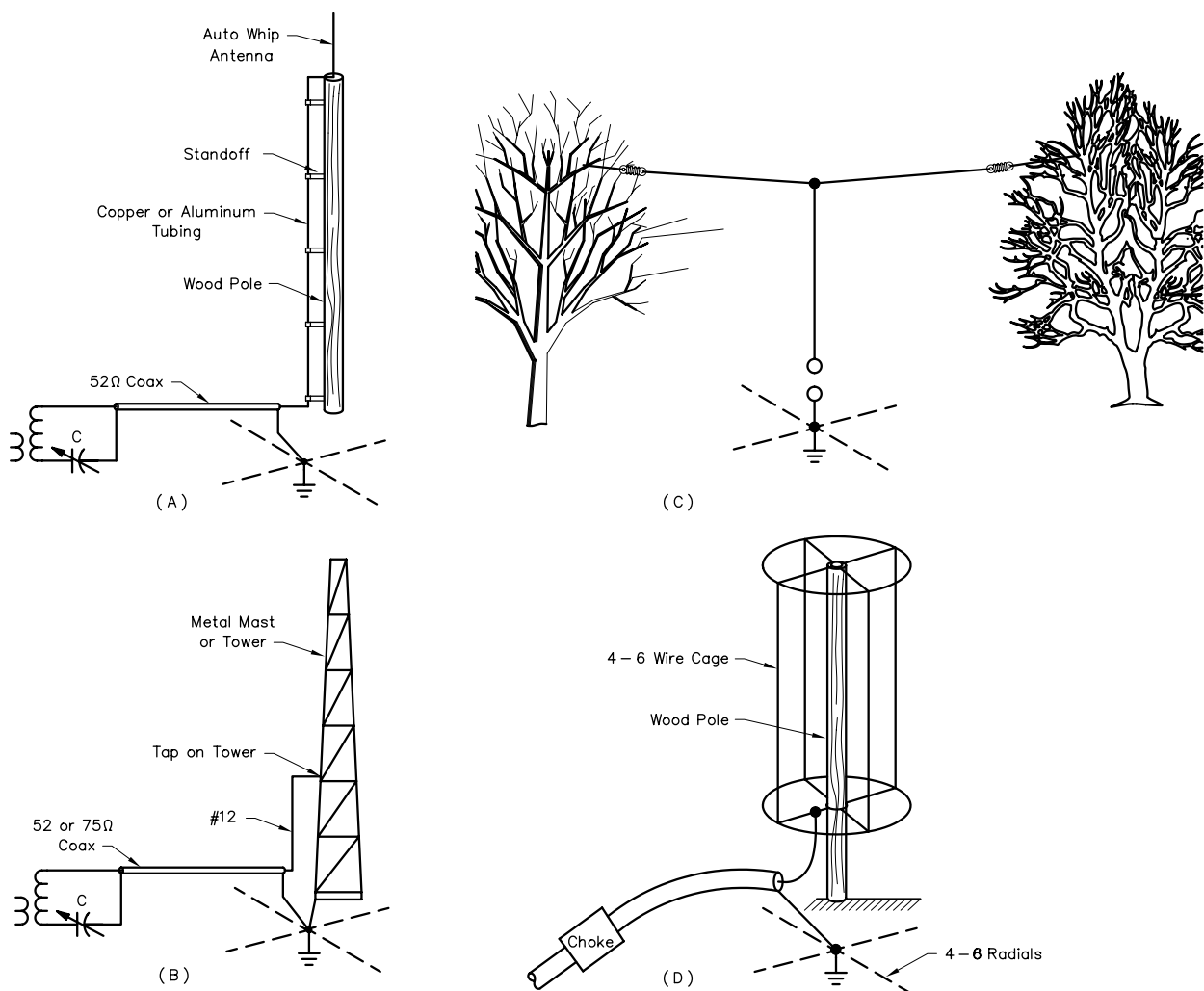
There are many possible ways to build a vertical antenna—the limits are set by your ingenuity. The primary problem is creating the vertical portion of the antenna with sufficient height. Some of the more common means are:

- A dedicated tower
- Using an existing tower with an HF Yagi on top
- A wire suspended from a tree limb or the side of a building
- A vertical wire supported by a line between two trees or other supports

- A tall pole supporting a conductor
- Flagpoles
- Light standards
- Irrigation pipe
- TV masts

If you have the space and the resources, the most straightforward means is to erect a dedicated tower for a vertical. While this is certainly an effective approach, many amateurs do not have the space or the funds to do this, especially if they already have a tower with an HF antenna on the top. The existing tower can be used as a top-loaded vertical, using shunt feed and a ground radial system. A system like this is shown in **Fig 19B**.

For those who live in an area with tall trees, it may be



**Fig 19**—Vertical antennas are effective for 3.5 or 7-MHz work. The  $\lambda/4$  antenna shown at A is fed directly with 50- $\Omega$  coaxial line, and the resulting SWR is usually less than 1.5 to 1, depending on the ground resistance. If a grounded antenna is used as at B, the antenna can be shunt fed with either 50 or 75- $\Omega$  coaxial line. The tap for best match and the value of C will have to be found by experiment. The line running up the side of the antenna should be spaced 6 to 12 inches from the antenna. If tall trees are available the antenna can be supported from a line suspended between the trees, as shown in C. If the vertical section is not long enough then the horizontal support section can be made of wire and act as top loading. A pole or even a grounded tower can be used with elevated radials if a cage of four to six wires is provided as shown in D. The cage surrounds the pole which may be wood or a grounded conductor.

possible to install a support rope between two trees, or between a tree and an existing tower. (Under no circumstances should you use an active utility pole!) The vertical portion of the antenna can be a wire suspended from the support line to ground, as shown in Fig 19C. If top loading is needed, some or all of the support line can be made part of the antenna.

Your local utility company will periodically have older power poles that they no longer wish to keep in service. These are sometimes available at little or no expense. If you see a power line under reconstruction or repair in your area you might stop and speak with the crew foreman. Sometimes they will have removed older poles they will not use again and will have to haul them back to their shop for disposal. Your offer for local “disposal” may well be accepted. Such a pole can be used in conjunction with a tubing or whip extension such as that shown in Fig 19A. Power poles are not your only option. In some areas of the US, such as the southeast or northwest, tall poles made directly from small conifers are available.

Freestanding (unguyed) flagpoles and roadway illumination standards are available in heights exceeding 100 feet. These are made of fiberglass, aluminum or galvanized steel. All of these are candidates for verticals. Flagpole suppliers are listed under “Flags and Banners” in your Yellow Pages. For lighting standards (lamp posts), you can contact a local electrical hardware distributor. Like a wooden pole, a fiberglass flagpole does not require a base insulator, but metal poles do. Guy wires will be needed.

One option to avoid the use of guys and a base insulator is to mount the pole directly into the ground as originally intended and then use shunt feed. If you want to keep the pole grounded but would like to use elevated radials, you can attach a cage of wires (four to six) at the top as shown in Fig 19D. The cage surrounds the pole and allows the pole (or tower for that matter) to be grounded while allowing elevated radials to be used. The use of a cage of wires surrounding the pole or tower is a very good way to increase the effective diameter. This reduces the Q of the antenna, thereby increasing the bandwidth. It can also reduce the conductor loss, especially if the pole is galvanized steel, which is not a very good RF conductor.

Aluminum irrigation tubing, which comes in diameters of 3 and 4 inches and in lengths of 20 to 40 feet, is widely available in rural areas. One or two lengths of tubing connected together can make a very good vertical when guyed with non-conducting line. It is also very lightweight and relatively easy to erect. A variety of TV masts are available which can also be used for verticals.

### **1.8-3.5 MHz VERTICAL USING AN EXISTING TOWER**

A tower can be used as a vertical antenna, provided that a good ground system is available. The shunt-fed tower is at its best on 1.8 MHz, where a full  $\lambda/4$  vertical antenna is rarely possible. Almost any tower height can be used. If the beam

structure provides some top loading, so much the better, but anything can be made to radiate—if it is fed properly. W5RTQ uses a self-supporting, aluminum, crank-up, tilt-over tower, with a TH6DXX tribander mounted at 70 feet. Measurements showed that the entire structure has about the same properties as a 125-foot vertical. It thus works quite well as an antenna on 1.8 and 3.5 MHz for DX work requiring low-angle radiation.

### **Preparing the Structure**

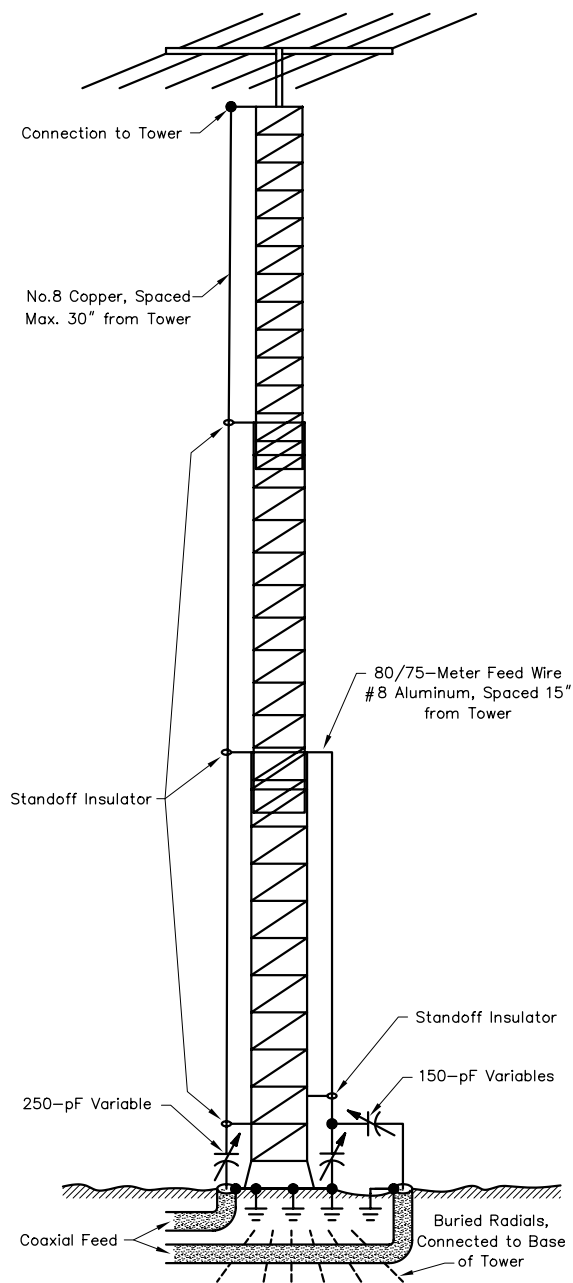
Usually some work on the tower system must be done before shunt-feeding is tried. If present, metallic guys should be broken up with insulators. They can be made to simulate top loading, if needed, by judicious placement of the first insulators. Don't overdo it; there is no need to “tune the radiator to resonance” in this way since a shunt feed is employed. If the tower is fastened to a house at a point more than about one-fourth of the height of the tower, it may be desirable to insulate the tower from the building. Plexiglas sheet, 1/4-inch or more thick, can be bent to any desired shape for this purpose, if it is heated in an oven and bent while hot.

All cables should be taped tightly to the tower, on the inside, and run down to the ground level. It is not necessary to bond shielded cables to the tower electrically, but there should be no exceptions to the down-to-the-ground rule.

A good system of buried radials is very desirable. The ideal would be 120 radials, each 250 feet long, but fewer and shorter ones must often suffice. You can lay them around corners of houses, along fences or sidewalks, wherever they can be put a few inches under the surface, or even on the earth's surface. Aluminum clothesline wire may be used extensively in areas where it will not be subject to corrosion. Neoprene-covered aluminum wire will be better in highly acid soils. Contact with the soil is not important. Deep-driven ground rods and connection to underground copper water pipes may be helpful, if available, especially to provide some protection from lightning.

### **Installing the Shunt Feed**

Principal details of the shunt-fed tower for 1.8 and 3.5 MHz are shown in Fig 20. Rigid rod or tubing can be used for the feed portion, but heavy gauge aluminum or copper wire is easier to work with. Flexible stranded #8 copper wire is used at W5RTQ for the 1.8-MHz feed, because when the tower is cranked down, the feed wire must come down with it. Connection is made at the top, 68 feet, through a 4-foot length of aluminum tubing clamped to the top of the tower, horizontally. The wire is clamped to the tubing at the outer end, and runs down vertically through standoff insulators. These are made by fitting 12-inch lengths of PVC plastic water pipe over 3-foot lengths of aluminum tubing. These are clamped to the tower at 15 to 20-foot intervals, with the bottom clamp about 3 feet above ground. These lengths allow for adjustment of the tower-to-wire spacing over a range of about 12 to 36 inches, for impedance matching.



**Fig 20—Principal details of the shunt-fed tower at W5RTQ. The 1.8-MHz feed, left side, connects to the top of the tower through a horizontal arm of 1-inch diameter aluminum tubing. The other arms have standoff insulators at their outer ends, made of 1-foot lengths of plastic water pipe. The connection for 3.5-4 MHz, right, is made similarly, at 28 feet, but two variable capacitors are used to permit adjustment of matching with large changes in frequency.**

The gamma-match capacitor for 1.8 MHz is a 250-pF variable with about  $\frac{1}{6}$ -inch plate spacing. This is adequate for power levels up to about 200 watts. A large transmitting or a vacuum-variable capacitor should be used for high-power applications.

## Tuning Procedure

The 1.8-MHz feed wire should be connected to the top of the structure if it is 75 feet tall or less. Mount the standoff insulators so as to have a spacing of about 24 inches between wire and tower. Pull the wire taut and clamp it in place at the bottom insulator. Leave a little slack below to permit adjustment of the wire spacing, if necessary.

Adjust the series capacitor in the 1.8-MHz line for minimum reflected power, as indicated on an SWR meter connected between the coax and the connector on the capacitor housing. Make this adjustment at a frequency near the middle of your expected operating range. If a high SWR is indicated, try moving the wire closer to the tower. Just the lower part of the wire need be moved for an indication as to whether reduced spacing is needed. If the SWR drops, move all insulators closer to the tower, and try again.

If the SWR goes up, increase the spacing. There will be a practical range of about 12 to 36 inches. If going down to 12 inches does not give a low SWR, try connecting the top a bit farther down the tower. If wide spacing does not make it, the omega match shown for 3.5-MHz work should be tried. No adjustment of spacing is needed with the latter arrangement, which may be necessary with short towers or installations having little or no top loading.

The two-capacitor arrangement in the omega match is also useful for working in more than one 25-kHz segment of the 1.8-MHz band. Tune up on the highest frequency, say 1990 kHz, using the single capacitor, making the settings of wire spacing and connection point permanent for this frequency. To move to the lower frequency, say 1810 kHz, connect the second capacitor into the circuit and adjust it for the new frequency. Switching the second capacitor in and out then allows changing from one segment to the other, with no more than a slight retuning of the first capacitor.

## SIMPLE, EFFECTIVE, ELEVATED GROUND-PLANE ANTENNAS

This section describes a simple and effective means of using a grounded tower, with or without top-mounted antennas, as an elevated ground-plane antenna for 80 and 160 meters. It first appeared in a June 1994 *QST* article by [Thomas Russell, N4KG](#).

### From Sloper to Vertical

Recall the quarter-wavelength sloper, also known as the *half-sloper*. It consists of an isolated quarter wavelength of wire, sloping from an elevated feed point on a grounded tower. Best results are usually obtained when the feed point is somewhere below a top-mounted Yagi antenna. You feed a sloper by attaching the center conductor of a coaxial cable to the wire and the braid of the cable to the tower leg. Now, imagine four (or more) slopers, but instead of feeding each individually, connect them together to the center conductor of a single feed line. Voilà! Instant elevated ground plane.

Now, all you need to do is determine how to tune the antenna to resonance. With no antennas on the top of the



tower, the tower can be thought of as a fat conductor and should be approximately 4% shorter than a quarter wavelength in free space. Calculate this length and attach four insulated quarter-wavelength radials at this distance from the top of the tower. For 80 meters, a feed point 65 feet below the top of an unloaded tower is called for. The tower guys must be broken up with insulators for all such installations. For 160 meters, 130 feet of tower above the feed point is needed.

What can be done with a typical grounded-tower-and-Yagi installation? A top-mounted Yagi acts as a large capacitance hat, top loading the tower. Fortunately, top loading is the most efficient means of loading a vertical antenna.

The examples in **Table 2** should give us an idea of how much top loading might be expected from typical amateur antennas. The values listed in the *Equivalent Loading* column tell us the approximate vertical height replaced by the antennas listed in a top-loaded vertical antenna. To arrive at the remaining amount of tower needed for resonance, subtract these numbers from the non-loaded tower height needed for resonance. Note that for all but the 10-meter antennas, the equivalent loading equals or exceeds a quarter wavelength on 40 meters. For typical HF Yagis, this method is best used only on 80 and 160 meters.

### Construction Examples

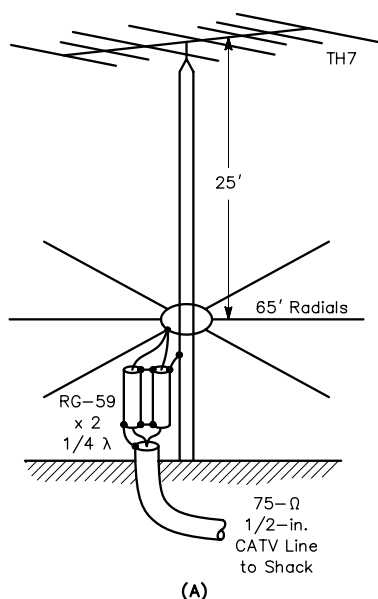
Consider this example: A TH7 triband Yagi mounted on a 40-foot tower. The TH7 has approximately the same overall dimensions as a full-sized 3-element 20-meter beam, but has more interlaced elements. Its equivalent loading is estimated to be 40 feet. At 3.6 MHz, 65 feet of tower is needed without loading. Subtracting 40 feet of equivalent loading, the feed point should be 25 feet below the TH7 antenna.

Ten quarter-wavelength (65-foot) radials were run from a nylon rope tied between tower legs at the 15-foot level, to various supports 10 feet high. Nylon cord was tied to the insulated, stranded, #18 wire, without using insulators. The radials are all connected together and to the center of an exact half wavelength (at 3.6 MHz) of RG-213 coax, which will repeat the antenna feed impedance at the other end. **Fig 21** is a drawing of the installation. The author used a Hewlett-Packard low-frequency impedance analyzer to measure the input impedance across the 80-meter band. An exact resonance (zero reactance) was seen at 3.6 MHz, just as predicted. The radiation resistance was found to be 17 Ω. The next question is, how to feed and match the antenna.

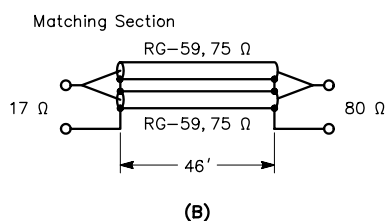
One good approach to 80-meter antennas is to tune them to the low end of the band, use a low-loss transmission line, and switch an antenna tuner in line for operation in the higher portions of the band. With a 50-Ω line, the 17-Ω radiation resistance represents a 3:1 SWR, meaning that an antenna tuner should be in-line for all frequencies. For short runs, it would be permissible to use RG-8 or RG-213 directly to the tuner. If you have a plentiful supply of low-loss 75-Ω

**Table 2**  
**Effective Loading of Common Yagi Antennas**

Antenna	Boom Length (feet)	S (area, ft <sup>2</sup> )	Equivalent Loading (feet)
3L 20	24	768	39
5L 15	26	624	35
4L 15	20	480	31
3L 15	16	384	28
5L 10	24	384	28
4L 10	18	288	24
3L 10	12	192	20
TH7	24	—	40 (estimated)
TH3	14	—	27 (estimated)



**Fig 21—At A, an 80-meter top-loaded, reverse-fed elevated ground plane, using a 40-foot tower carrying a TH7 triband Yagi antenna. At B, dimensions of the 3.6-MHz matching network, made from RG-59.**



CATV rigid coax, you can take another approach.

Make a quarter-wave (70 feet  $\times$  0.66 velocity factor = 46 feet) 37-Ω matching line by paralleling two pieces of RG-59 and connecting them between the feed point and a run of the rigid coax to the transmitter. The magic of quarter-wave matching transformers is that the input impedance ( $R_i$ ) and output impedance ( $R_o$ ) are related by:

$$Z_0^2 = R_i \times R_o \quad (\text{Eq 2})$$

For  $R_i = 17 \Omega$  and  $Z_0 = 37 \Omega$ ,  $R_o = 80 \Omega$ , an almost

perfect match for the 75- $\Omega$  CATV coax. The resulting 1.6:1 SWR at the transmitter is good enough for CW operation without a tuner.

### 160-Meter Operation

On the 160-meter band, a resonant quarter-wavelength requires 130 feet of tower above the radials. That's a pretty tall order. Subtracting 40 feet of top loading for a 3-element 20-meter or TH7 antenna brings us to a more reasonable 90 feet above the radials. Additional top loading in the form of more antennas will reduce that even more.

Another installation, using stacked TH6s on a 75-foot tower, is shown in **Fig 22**. The radials are 10 feet off the ground.

### PHASED VERTICALS

Two or more vertical antennas spaced apart can be operated as a single antenna system to obtain additional gain and a directional pattern. There is an extensive discussion of phased arrays in Chapter 8. Much of this material is useful for low-band antennas.

### The Half-Square Antenna

The *half-square* antenna is a very simple form of vertical two-element phased array that can be very effective on the low bands. The following section was originally

presented in *The ARRL Antenna Compendium Vol 5*, by [Rudy Severns, N6LF](#).

A simple modification to a standard dipole is to add two  $\lambda/4$  vertical wires, one at each end, as shown in **Fig 23**. This makes a *half-square antenna*. The antenna can be fed at one corner (low-impedance, current fed) or at the lower end of one of the vertical wires (high-impedance, voltage fed). Other feed arrangements are also possible.

The "classical" dimensions for this antenna are  $\lambda/2$  (131 feet at 3.75 MHz) for the top wire and  $\lambda/4$  (65.5 feet) for the vertical wires. However, there is nothing sacred about these dimensions! They can vary over a wide range and still obtain nearly the same performance.

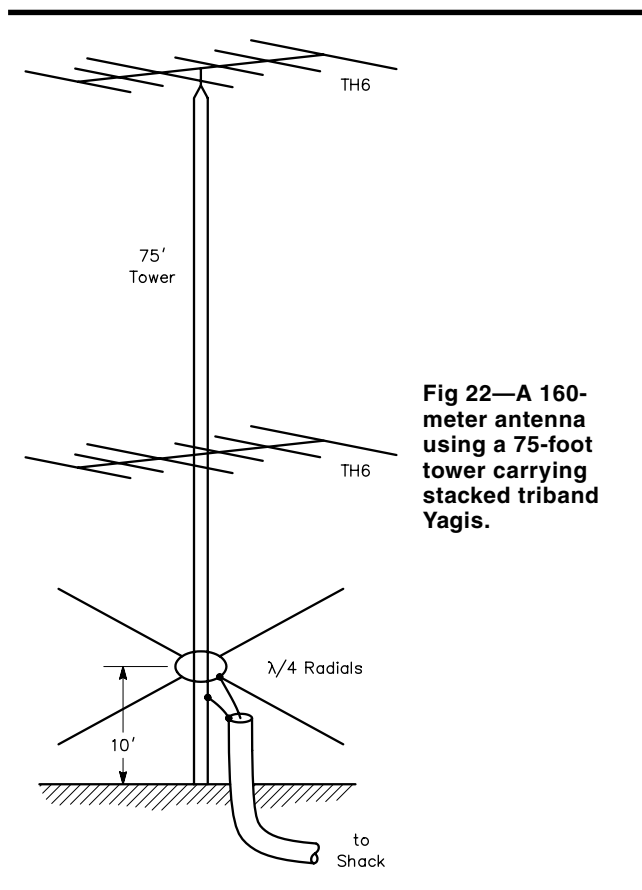
This antenna is two  $\lambda/4$  verticals, spaced  $\lambda/2$ , fed in-phase by the top wire. The current maximums are at the top corners. The theoretical gain over a single vertical is 3.8 dB. An important advantage of this antenna is that it does not require the extensive ground system and feed arrangements that a conventional pair of phased  $\lambda/4$  verticals would.

### Comparison to a Dipole

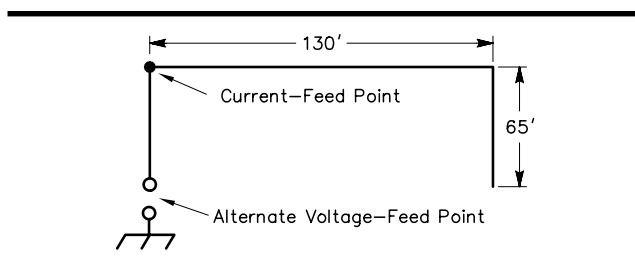
In the past, one of the things that has turned off potential users of the half-square on 80 and 160 meters is the perceived need for  $\lambda/4$  vertical sections. This forces the height to be >65 feet on 80 meters and >130 feet on 160 meters. That's not really a problem. If you don't have the height there are several things you can do. For example, just fold the ends in, as shown in **Fig 24**. This compromises the performance surprisingly little.

It is helpful to compare the examples given in Figs 23 and 24 to dipoles at the same height. Two heights, 40 and 80 feet, and average, very good and sea water grounds, were used for this comparison. It is also assumed that the lower end of the vertical wires had to be a minimum of 5 feet above ground.

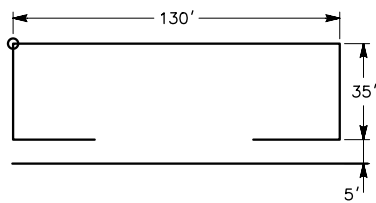
At 40 feet the half-square is really mangled, with only 35-foot high ( $\approx \lambda/8$ ) vertical sections. The comparison between this antenna and a dipole of the same height is shown in **Fig 25**. Over average ground the half-square is superior below



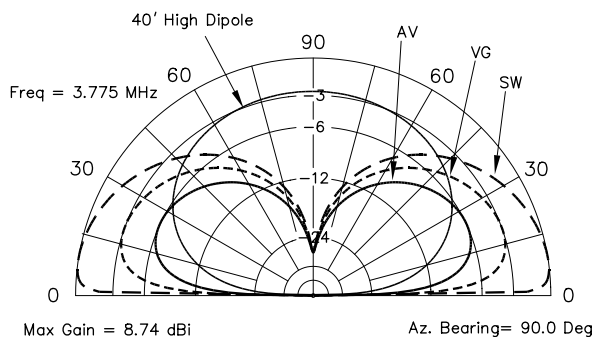
**Fig 22—A 160-meter antenna using a 75-foot tower carrying stacked triband Yagis.**



**Fig 23—Typical 80-meter half-square, with  $\lambda/4$ -high vertical legs and a  $\lambda/2$ -long horizontal leg. The antenna may be fed at the bottom or at a corner. When fed at a corner, the feed point is a low-impedance, current-feed. When fed at the bottom of one of the wires against a small ground counterpoise, the feed point is a high-impedance, voltage-feed.**



**Fig 24—An 80-meter half-square configured for 40-foot high supports. The ends have been bent inward to resonate the antenna. The performance is compromised surprisingly little.**



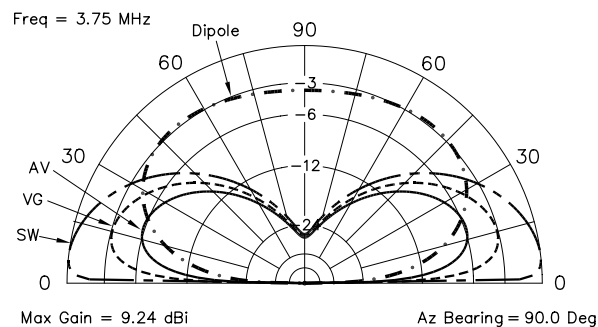
**Fig 25—Comparison of 80-meter elevation response of 40-foot high, horizontally polarized dipole over average ground and a 40-foot high, vertically polarized half-square, over three types of ground: average (conductivity  $\sigma = 5$  mS/m, dielectric constant  $\epsilon = 13$ ), very good ( $\sigma = 30$  mS/m,  $\epsilon = 20$ ) and salt water ( $\sigma = 5000$  mS/m,  $\epsilon = 80$ ). The quality of the ground clearly has a profound effect on the low-angle performance of the half-square. Even over average ground, however, the half-square outperforms the low dipole below about  $32^\circ$ .**

$32^\circ$  and at  $15^\circ$  is almost 5 dB better. That is a worthwhile improvement. If you have very good soil conductivity, like parts of the lower Midwest and South, then the half-square will be superior below  $38^\circ$  and at  $15^\circ$  will be nearly 8 dB better. For those fortunate few with saltwater frontal property the advantage at  $15^\circ$  is 11 dB! Notice also that above  $35^\circ$ , the response drops off rapidly. This is great for DX but is not good for local work.

If we push both antennas up to 80 feet (**Fig 26**) the differences become smaller and the advantage over average ground is 3 dB at  $15^\circ$ . The message here is that the lower your dipole and the better your ground, the more you have to gain by switching from a dipole to a half-square. The half-square antenna looks like a good bet for DXing.

### Changing the Shape

Just how flexible is the shape? There are several common distortions of practical importance. Some have very little effect but a few are fatal to the gain. Suppose you have either more height and less width than called for in the



**Fig 26—Comparison of 80-meter elevation response of 80-foot high, horizontally polarized dipole over average ground and an 80-foot high, vertically polarized half-square, over same three types of ground as in Fig 25: average, good and salt water. The greater height of the dipole narrows the gap in performance at low elevation angles, but the half-square is still a superior DX antenna, especially when the ground nearby is salt water! For local, high-angle contacts, the dipole is definitely the winner, by almost 20 dB when the angle is near  $90^\circ$ .**

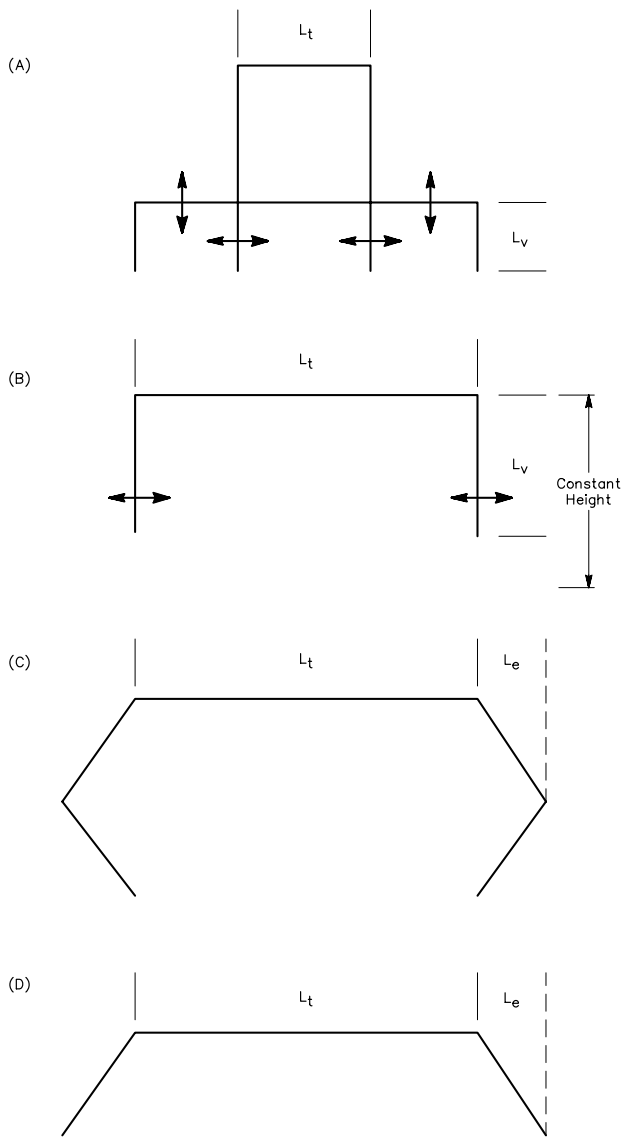
standard version or more width and less height, as shown in **Fig 27A**.

The effect on gain from this type of dimensional variation is given in **Table 3**. For a top length ( $L_T$ ) varying between 110 and 150 feet, where the vertical wire lengths ( $L_V$ ) readjusted to resonate the antenna, the gain changes only by 0.6 dB. For a 1 dB change the range of  $L_T$  is 100 to 155 feet, a pretty wide range.

Another variation results if we vary the length of the horizontal top wire and readjust the vertical wires for resonance, while keeping the top at a constant height. See **Fig 27B**. **Table 4** shows the effect of this variation on the peak gain. For a range of  $L_T = 110$  to 145 feet, the gain changes only 0.65 dB.

The effect of bending the ends into a V shape, as shown in **Fig 27C**, is given in **Table 5**. The bottom of the antenna is kept at a height of 5 feet and the top height ( $H$ ) is either 40 or 60 feet. Even this gross deformation has only a relatively small effect on the gain. Sloping the ends outward as shown in **Fig 27D** and varying the top length also has only a small effect on the gain. While this is good news because it allows you dimension the antenna to fit different QTHs, not all distortions are so benign.

Suppose the two ends are not of the same height, as illustrated in **Fig 28**, where one end of the half-square is 20 feet higher than the other. The radiation pattern for this antenna is shown in **Fig 29** compared to a dipole at 50 feet. This type of distortion does affect the pattern. The gain drops somewhat and the zenith null goes away. The nulls off the end of the antenna also go away, so that there is some end-fire radiation. In this example the difference in height is fairly extreme at 20 feet. Small differences of 1 to 5 feet do not affect the pattern seriously.



**Fig 27—Varying the horizontal and vertical lengths of a half-square. At A, both the horizontal and vertical legs are varied, while keeping the antenna resonant. At B, the height of the horizontal wire is kept constant, while its length and that of the vertical legs is varied to keep the antenna resonant. At C, the length of the horizontal wire is varied and the legs are bent inward in the shape of “vees.” At D, the ends are sloped outward and the length of the flattop portion is varied. All these symmetrical forms of distortion of the basic half-square shape result in small performance losses.**

If the top height is the same at both ends but the length of the vertical wires is not the same, then a similar pattern distortion can occur. The antenna is very tolerant of symmetrical distortions but it is much less accepting of asymmetrical distortion.

What if the length of the wires is such that the antenna is not resonant? Depending on the feed arrangement, that may or may not matter. We will look at that issue later on,

**Table 3  
Variation in Gain with Change in Horizontal Length, with Vertical Height Readjusted for Resonance (see Fig 27A)**

$L_T$ (feet)	$L_V$ (feet)	Gain (dBi)
100	85.4	2.65
110	79.5	3.15
120	73.7	3.55
130	67.8	3.75
140	61.8	3.65
150	56	3.05
155	53	2.65

**Table 4  
Variation in Gain with Change in Horizontal Length, with Vertical Length Readjusted for Resonance, but Horizontal Wire Kept at Constant Height (see Fig 27B)**

$L_T$ (feet)	$L_V$ (feet)	Gain (dBi)
110	78.7	3.15
120	73.9	3.55
130	68	3.75
140	63	3.35
145	60.7	3.05

**Table 5  
Gain for Half-Square Antenna, Where Ends Are Bent Into V-Shape (see Fig 27C)**

$L_T$ (feet)	Height $\Rightarrow$ H=40' H=40' H=60' H=60'			
	$L_e$ (feet)	Gain (dBi)	$L_e$ (feet)	Gain (dBi)
40	57.6	3.25	52.0	2.75
60	51.4	3.75	45.4	3.35
80	45.2	3.95	76.4	3.65
100	38.6	3.75	61.4	3.85
120	31.7	3.05	44.4	3.65
140	—	—	23	3.05

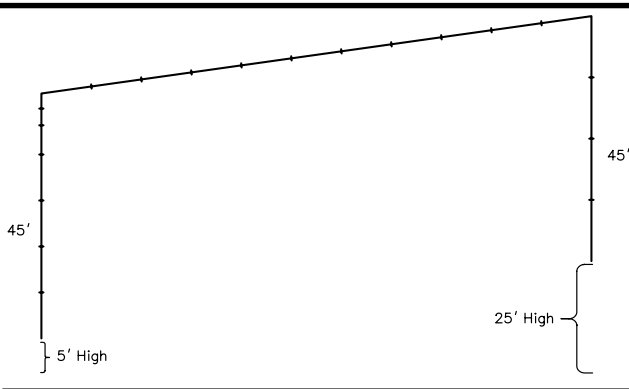
in the section on patterns versus frequency. The half-square antenna, like the dipole, is very flexible in its proportions.

### Feed-Point Impedance

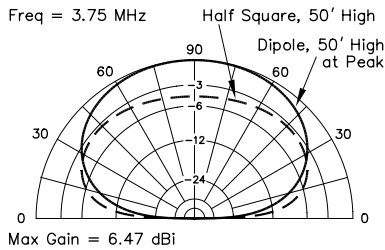
There are many different ways to feed the half-square. Traditionally the antenna has been fed either at the end of one of the vertical sections, against ground, or at one of the upper corners as shown in Fig 23.

For voltage feed at the bottom against ground, the impedance is very high, on the order of several thousand ohms. For current feed at a corner, the impedance is much lower and is usually close to 50  $\Omega$ . This is very convenient for direct feed with coax.

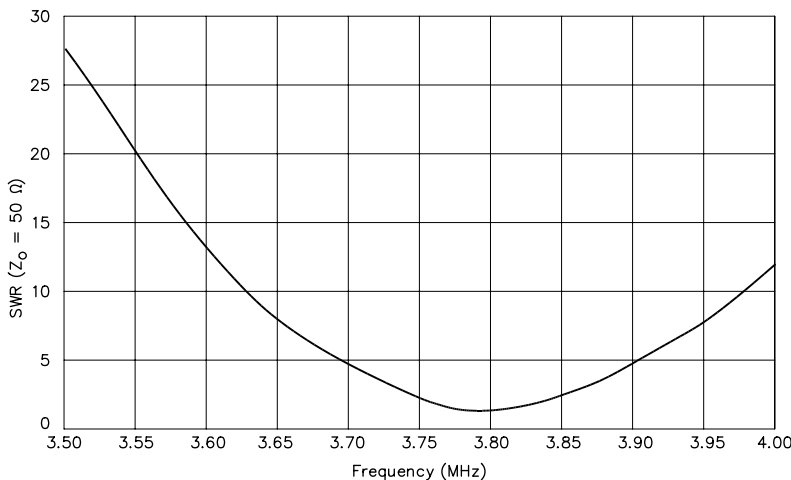
The half-square is a relatively high-Q antenna ( $Q \approx 17$ ). Fig 30 shows the SWR variation with frequency for this feed arrangement. An 80-meter dipole is not



**Fig 28—An asymmetrical distortion of the half-square antenna, where the bottom of one leg is purposely made 20 feet higher than the other. This type of distortion does affect the pattern!**



**Fig 29—Elevation pattern for the asymmetrical half-square shown in Fig 28, compared with pattern for a 50-foot high dipole. This is over average ground, with a conductivity of 5 mS/m and a dielectric constant of 13. Note that the zenith-angle null has filled in and the peak gain is lower compared to conventional half-square shown in Fig 25 over the same kind of ground.**



**Fig 30—Variation of SWR with frequency for current-fed half-square antenna. The SWR bandwidth is quite narrow.**

particularly wideband either, but a dipole will have less extreme variation in SWR than the half-square.

### Patterns Versus Frequency

Impedance is not the only issue when defining the bandwidth of an antenna. The effect on the radiation pattern of changing frequency is also a concern. For a voltage-fed half-square, the current distribution changes with frequency. For an antenna resonant near 3.75 MHz, the current distribution is nearly symmetrical. However, above and below resonance the current distribution increasingly becomes asymmetrical. In effect, the open end of the antenna is constrained to be a voltage maximum but the feed point can behave less as a voltage point and more like a current maxima. This allows the current distribution to become asymmetrical.

The effect is to reduce the gain by  $-0.4$  dB at 3.5 MHz and by  $-0.6$  dB at 4 MHz. The depth of the zenith null is reduced from  $-20$  dB to  $-10$  dB. The side nulls are also reduced. Note that this is exactly what happened when the antenna was made physically asymmetrical. Whether the asymmetry is due to current distribution or mechanical arrangements, the antenna pattern will suffer.

When current-feed at a corner is used, the asymmetry introduced by off-resonance operation is much less, since both ends of the antenna are open circuits and constrained to be voltage maximums. The resulting gain reduction is only  $-0.1$  dB. It is interesting that the sensitivity of the pattern to changing frequency depends on the feed scheme used.

Of more concern for corner feed is the effect of the transmission line. The usual instruction is to simply feed the antenna using coax, with the shield connected to vertical wire and the center conductor to the top wire. Since the shield of the coax is a conductor, more or less parallel with the radiator, and is in the immediate field of the antenna, you

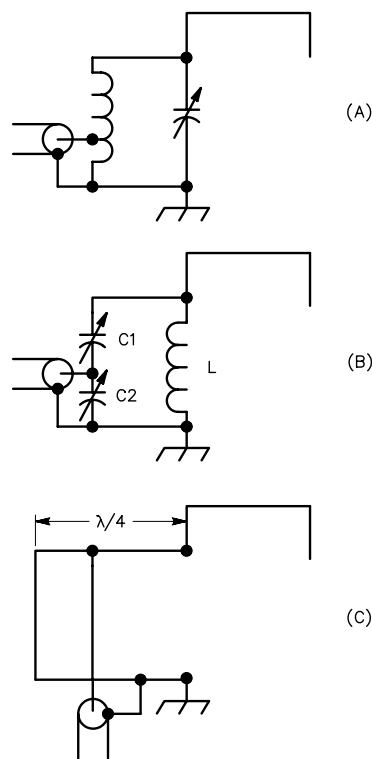
might expect the pattern to be seriously distorted by this practice. This arrangement seems to have very little effect on the pattern. The greatest effect is when the feed-line length was near a multiple of  $\lambda/2$ . Such lengths should be avoided.

Of course, you may use a choke balun at the feed point if you desire. This might reduce the coupling to the feed line even further but it doesn't appear to be worth the trouble. In fact, if you use an antenna tuner in the shack to operate away from resonance with a very high SWR on the transmission line, a balun at the feed point would take a beating.

### Voltage-Feed at One End of Antenna: Matching Schemes

Several straightforward means are available for narrow-band matching. However, broadband matching over the full 80-meter band is much more challenging. Voltage feed with a parallel-resonant circuit and a modest local ground, as shown in **Fig 31**, is the traditional matching scheme for this antenna. Matching is achieved by resonating the circuit at the desired frequency and tapping down on the inductor in Fig 31A or using a capacitive divider (Fig 31B). It is also possible to use a  $\lambda/4$  transmission-line matching scheme, as shown in Fig 31C.

If the matching network shown in Fig 31B is used, typical values for the components would be:  $L = 15 \mu\text{H}$ ,  $C1 = 125 \text{ pF}$  and  $C2 = 855 \text{ pF}$ . At any single point the SWR can be made very close to 1:1 but the bandwidth for SWR  $< 2:1$  will be very narrow at  $< 100 \text{ kHz}$ . Altering the L-C ratio doesn't make very much difference. The half-square antenna has a well-earned reputation for being narrowband.



**Fig 31**—Typical matching networks used for voltage-feeding a half-square antenna.

## Short Antennas

On the lower frequencies it becomes increasingly difficult to accommodate a full  $\lambda/4$  vertical height and full-sized  $\lambda/4$  radials. In fact, it is not absolutely necessary to make the antenna full size, whether it is a grounded antenna or a ground-plane antenna. The size of the antenna can be reduced by half or even more and still retain high efficiency and the desired radiation pattern. This requires careful design, however. If high efficiency is maintained, the operating bandwidth of the shortened antenna will be reduced because the shortened antenna will have a higher Q.

This translates into a more rapid increase of reactance away from resonance. The effect can be mitigated to some extent by using larger-diameter conductors. Even doing this however, bandwidth will be a problem, particularly on the 3.5 to 4-MHz band, which is very wide in proportion to the center frequency.

If we take a vertical with a diameter of 2 inches and a frequency of 3.525 MHz and progressively shorten it, the feed-point impedance and efficiency (using an inductor at the base to tune out the capacitive reactance) will vary as

shown in **Table 6**. In this example perfect ground and conductor are assumed. Real ground will not make a great difference in the impedance but will introduce ground loss, which will reduce the efficiency further. Conductor loss will also reduce efficiency. In general, higher  $R_R$  will result in better efficiency.

The important point of **Table 6** is the drastic reduction in  $R_R$  as the antenna gets shorter. This combined with the increasing loss resistance of the inductor ( $R_L$ ) used to tune out the increasing base reactance ( $X_C$ ), reduces the efficiency.

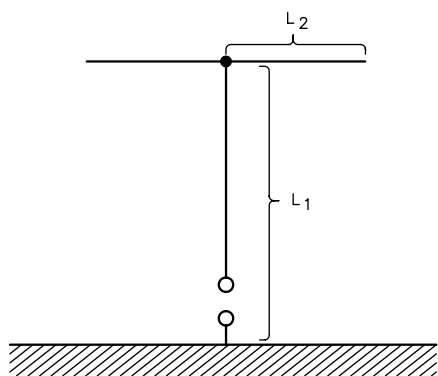
The base of the antenna is a convenient point at which to add a loading inductor, but it is usually not the lowest loss point at which an inductor, of a given Q, can be placed. There is an extensive discussion of the optimum location of the loading in a short vertical as a function of ground loss and inductor Q in **Chapter 16** for mobile antennas. This information should be reviewed before using inductive loading.

On the accompanying CD-ROM is a copy of the

**Table 6**  
**Effect of Shortening a Vertical Radiator Below  $\lambda/4$  Using Inductive Base Loading.**

Frequency is 3.525 MHz and for the inductor  $Q_L = 200$ .  
 Ground and Conductor Losses Are Omitted

Length (feet)	Length ( $\lambda$ )	$R_R$ ( $\Omega$ )	$X_C$ ( $\Omega$ )	$R_L$ ( $\Omega$ )	Efficiency (%)	Loss (dB)
14	0.050	0.96	-761	3.8	20	-7.0
20.9	0.075	2.2	-533	2.7	45	-3.5
27.9	0.100	4.2	-395	2.0	68	-1.7
34.9	0.125	6.8	-298	1.5	82	-0.86
41.9	0.150	10.4	-220	1.1	90	-0.44
48.9	0.175	15.1	-153	0.77	95	-0.22
55.8	0.200	21.4	-92	0.46	98	-0.09
62.8	0.225	29.7	-34	0.17	99	-0.02



**Fig 32—Horizontal wire used to top load a short vertical.**

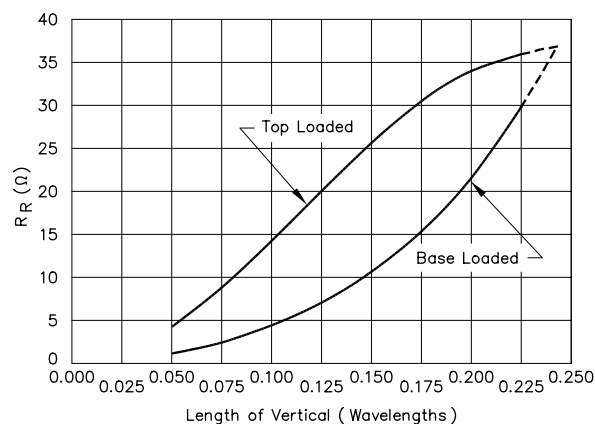
program *MOBILE.EXE*. This is an excellent tool for designing short, inductively loaded antennas. In most cases, where top loading is not used, the optimum point is near or a little above the middle of the vertical section. Moving the loading coil from the base to the middle of the antenna can make an important difference, increasing  $R_R$  and reducing the inductor loss. For example, in an antenna operating at 3.525 MHz, if we make  $L_1 = 34.9$  feet ( $0.125 \lambda$ ) the amount of loading inductor placed at the center is  $25.2 \mu\text{H}$ . This resonates the antenna. In this configuration  $R_R$  will increase from  $6.8 \Omega$  (base loading) to  $13.5 \Omega$  (center loading). This substantially increases the efficiency of the antenna, depending on the ground loss and conductor resistances.

Instead of a lumped inductance being inserted at some point in the antenna, it is also possible to use “continuous loading,” where the entire radiator is wound as a small diameter coil. The effect is to distribute the inductive loading all along the radiator. In this version of inductive loading the coil is the radiator. An example of a short vertical using this principle is given later in this chapter.

Inductive loading is not the only or even the best way to compensate for reduced antenna height. *Capacitive top*

**Table 7**  
**Effect of Shortening a Vertical using Top Loading**

$L_1$ (feet)	$L_2$ (feet)	Length ( $\lambda$ )	$R_R$ ( $\Omega$ )
14.0	48.8	0.050	4.0
20.9	38.6	0.075	8.5
27.9	30.1	0.100	14.0
34.9	22.8	0.125	19.9
41.9	17.3	0.150	25.5
48.9	11.9	0.175	30.4
55.8	7.0	0.200	33.9
62.8	2.4	0.225	35.7

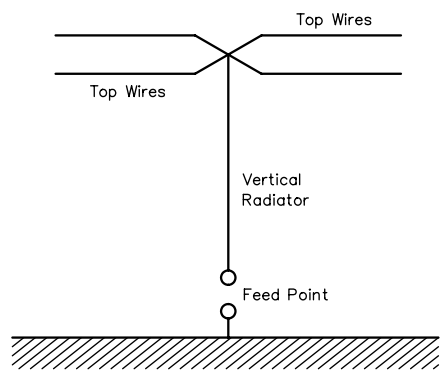


**Fig 33—Comparison of top (capacitive) and base (inductive) loading for short verticals. Sufficient loading is used to resonate the antenna.**

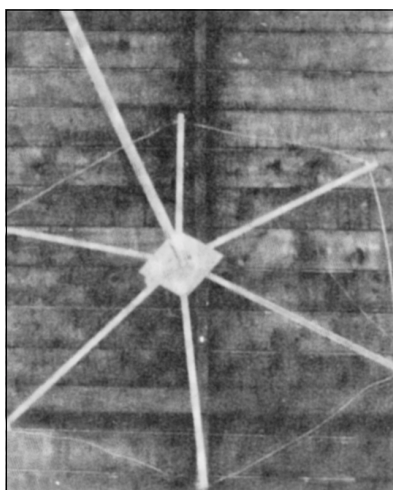
loading can also be used as indicated in Fig 32. Table 7 gives information on a shortened 3.525-MHz vertical using top loading. The vertical portion ( $L_1$ ) is made from 2-inch tubing. The top loading is also 2-inch tubing extending across the top like a T. The length of the top loading T ( $\pm L_2$ ) is adjusted to resonate the antenna. Again the ground and the conductors are assumed to be perfect in Table 7.

For a given vertical height, resonating the antenna with top loading results in much higher  $R_R$  —2 to 4 times. In addition, the loss associated with the loading element will be much smaller. The result is a much more efficient antenna for low heights. A comparison of  $R_R$  for both capacitive top loading and inductive base loading is given in Fig 33. For heights below  $0.15 \lambda$  the length of the top-loading elements becomes impractical but there are other, potentially more useful, top-loading schemes.

A multiwire system such as the one shown in Fig 34 has more capacitance than the single-conductor arrangement, and thus does not need to be as long to resonate at a given frequency. This design does, however, require extra supports for the additional wires. Ideally, an arrangement of this sort should be in the form of a cross, but parallel wires separated



**Fig 34—Multiple top wires can increase the effective capacitance substantially. This allows the use of shorter top wires to achieve resonance.**

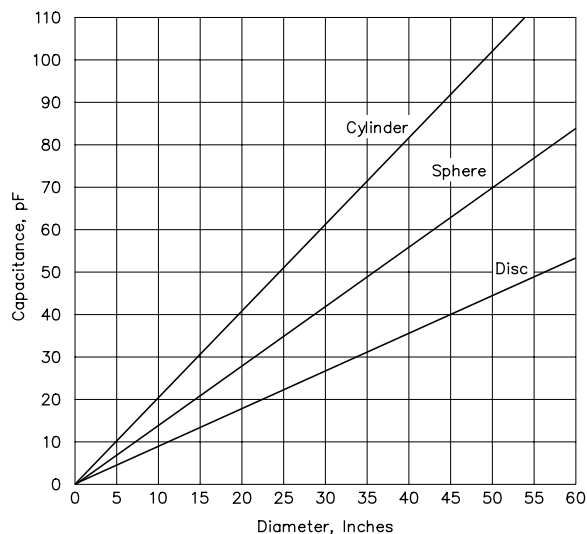


**Fig 35—A close-up view of the capacitance hat for a 7-MHz vertical antenna. The 1/2-in. diameter radial arms terminate in a loop of copper wire.**

by several feet give a considerable increase in capacitance over a single wire.

The top loading can be supplied by a variety of metallic structures large enough to have the necessary self-capacitance. For example, as shown in **Fig 35**, a multi-spoked structure with the ends connected together can be used. One simple way to make a capacitance hat is to take four to six, 8-foot fiberglass CB mobile whips, arrange them like spokes in a wagon wheel and connect the ends with a peripheral wire. This arrangement will produce a 16-foot diameter hat which is economical and very durable, even when loaded with ice. Practically any sufficiently large metallic structure can be used for this purpose, but simple geometric forms such as the sphere, cylinder and disc are preferred because of the relative ease with which their capacitance can be calculated.

The capacitance of three geometric forms can be estimated from the curves of **Fig 36** as a function of their size. For the cylinder, the length is specified equal to the diameter. The sphere, disc and cylinder can be constructed



**Fig 36—Capacitance of sphere, disc and cylinder as a function of their diameters. The cylinder length is assumed equal to its diameter.**

from sheet metal, if such construction is feasible, but the capacitance will be practically the same in each if a “skeleton” type of construction with screening or networks of wire or tubing are used.

### FINDING CAPACITANCE HAT SIZE

The required size of a capacitance hat may be determined from the following procedure. The information in this section is based on a September 1978 *QST* article by Walter Schulz, K3OQF. The physical length of a shortened antenna can be found from:

$$h_{\text{inches}} = \frac{11808}{F_{\text{MHz}}} \quad (\text{Eq 3})$$

where h = length in inches

Thus, using an example of 7 MHz and a shortened length of  $0.167 \lambda$ ,  $h = 11808/7 \times 0.167 = 282$  inches, equivalent to 23.48 feet.

Consider the vertical radiator as an open-ended transmission line, so the impedance and top loading may be determined. The characteristic impedance of a vertical antenna can be found from

$$Z_0 = 60 \left( \ln \left( \frac{4h}{d} \right) - 1 \right) \quad (\text{Eq 4})$$

where

ln = natural logarithm

h = length (height) of vertical radiator in inches (as above)

d = diameter of radiator in inches



The vertical radiator for this example has a diameter of 1 inch. Thus, for this example,

$$Z_0 = 60 \left( \ln \left( \frac{4 \times 281}{1} \right) - 1 \right) = 361 \Omega$$

The capacitive reactance required for the amount of top loading can be found from

$$X = \frac{Z_0}{\tan \theta} \quad (\text{Eq 5})$$

where

X = capacitive reactance, ohms

Z<sub>0</sub> = characteristic impedance of antenna (from Eq 4)

θ = amount of electrical loading, degrees

This value for a 30° hat is 361/tan 30° = 625 Ω. This capacitive reactance may be converted to capacitance with the following equation,

$$C = \frac{10^6}{2\pi f X_C} \quad (\text{Eq 6})$$

where

C = capacitance in pF

f = frequency, MHz

X<sub>C</sub> = capacitive reactance, ohms (from above)

For this example, the required C = 10<sup>6</sup>/(2π × 7 × 625) = 36.4 pF, which may be rounded to 36 pF. A disc capacitor is used in this example. The appropriate diameter for 36 pF of hat capacitance can be found from Fig 36. The disc diameter that yields 36 pF of capacitance is 40 inches.

The skeleton disc shown in Fig 35 is fashioned into a wagonwheel configuration. Six 20-inch lengths of 1/2-inch OD aluminum tubing are used as spokes. Each is connected to the hub at equidistant intervals. The outer ends of the spokes terminate in a loop made of #14 copper wire. Note that the loop increases the hat capacitance slightly, making a better approximation of a solid disc. The addition of this hat at the top of a 23.4-foot radiator makes it quarter-wave resonant at 7 MHz.

After construction, some slight adjustment in the radiator length or the hat size may be required if resonance at a specific frequency is desired. From Fig 33, the radiation resistance of a 0.167-λ high radiator is seen to be about 13 Ω without top loading. With top loading R<sub>r</sub> ≈ 25 Ω or almost double.

### LINEAR LOADING

An alternative to inductive loading is *linear loading*. This little-understood method of shortening radiators can be applied to almost any antenna configuration—including parasitic arrays. Although commercial antenna manufacturers make use of linear loading in their HF antennas, relatively few hams have used it in their own designs. Linear loading can be used to advantage in many antennas because it introduces very little loss, does not degrade directivity patterns, and has low enough Q to allow reasonably good bandwidth. Some examples of linear-loaded

antennas are shown in Fig 37.

Since the dimensions and spacing of linear-loading devices vary greatly from one antenna installation to another, the best way to employ this technique is to try a length of conductor 10% to 20% longer than the difference between the shortened antenna and the full-size dimension for the linear-loading device. Then use the “cut-and-try” method, varying both the spacing and length of the loading device to optimize the match. A hairpin at the feed point can be useful in achieving a 1:1 SWR at resonance.

### Linear-Loaded Short Wire Antennas

More detail on linear loading is provided in this section, which was originally presented in *The ARRL Antenna Compendium Vol 5* by John Stanford, NN0F. Linear loading can significantly reduce the required length for resonant antennas. For example, it is easy to make a resonant antenna that is as much as 30 to 40% shorter than an ordinary dipole for a given band. The shorter overall lengths come from bending back some of the wire. The increased self-coupling lowers the resonant frequency. These ideas are applicable to short antennas for restricted space or portable use.

### Experiments

The results of the measurements are shown in Fig 38 and are also consistent with values given by Rashed and Tai from an earlier paper. This shows several simple wire antenna configurations, with resonant frequencies and impedance (radiation resistance). The reference dipole has a resonant frequency f<sub>0</sub> and resistance R = 72 Ω. The f/f<sub>0</sub> values give the effective reduced frequency obtained with

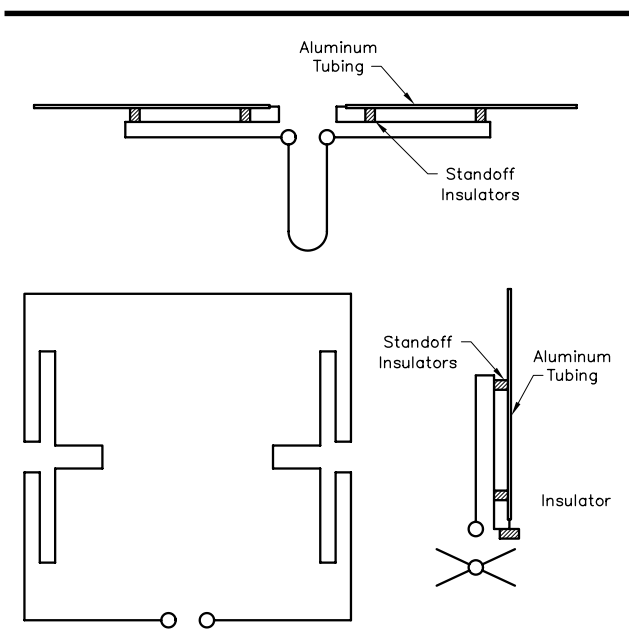


Fig 37—Some examples of linear loading. The small circles indicate the feed points of the antennas.

the linear loading in each case. For example, the two-wire linear-loaded dipole has its resonant frequency lowered to about 0.67 to 0.70 that of the simple reference dipole of the same length.

The three-wire linear-loaded dipole has its frequency reduced to 0.55 to 0.60 of the simple dipole of the same length. As you will see later, these values will vary with conductor diameter and spacing.

The two-wire linear-loaded dipole (Fig 38B) looks almost like a folded dipole but, unlike a folded dipole, it is open in the middle of the side opposite where the feed line is attached. Measurements show that this antenna structure has a resonant frequency lowered to about two-thirds that of the reference dipole, and R equal to about 35 Ω. A three-

wire linear-loaded dipole (Fig 38C) has an even lower resonant frequency and R about 25 to 30 Ω.

Linear-loaded monopoles (one half of the dipoles in Fig 38) working against a radial ground plane have similar resonant frequencies, but with only half the radiation resistance shown for the dipoles.

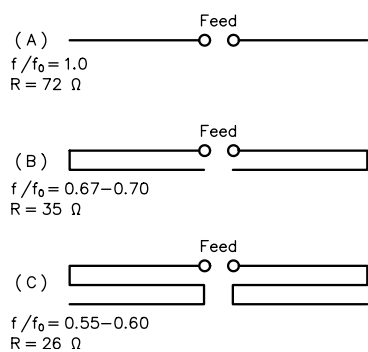
### A Ladder-Line Linear-Loaded Dipole

Based on these results, NN0F next constructed a linear-loaded dipole as in Fig 38B, using 24 feet of 1-inch ladder line (the black, 450-Ω plastic kind widely available) for the dipole length. He hung the system from a tree using nylon fishing line, about 4 feet from the tree at the top, and about 8 feet from the ground on the bottom end. It was slanted at about a 60° angle to the ground. This antenna resonated at 12.8 MHz and had a measured resistance of about 35 Ω. After the resonance measurements, he fed it with 1-inch ladder open-wire line (a total of about 100 feet to the shack).

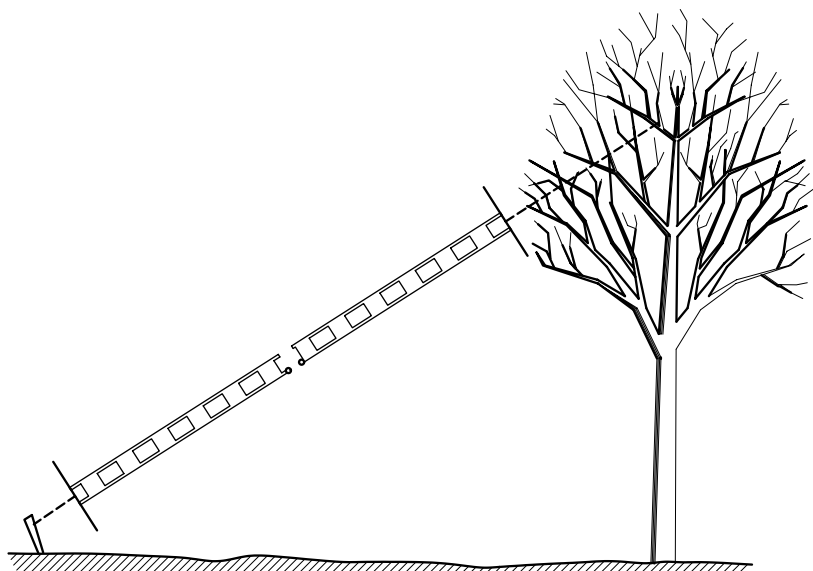
For brevity, this is called a vertical LLSD (linear-loaded short dipole). A tuner resonated the system nicely on 20 and 30 meters. On these bands the performance of the vertical LLSD seemed comparable to his 120-foot long, horizontal center-fed Zepp, 30 feet above ground. In some directions where the horizontal, all-band Zepp has nulls, such as toward Siberia, the vertical LLSD was definitely superior. This system also resonates on 17 and 40 meters. However, from listening to various signals, NN0F had the impression that this length LLSD is not as good on 17 and 40 meters as the horizontal 120-foot antenna.

### Using Capacitance “End Hats”

He also experimented with an even shorter resonant length by trying an LLSD with capacitance “end-hats.” The hats, as expected, increased the radiation resistance and



**Fig 38—Wire dipole antennas.** The ratio  $f/f_0$  is the measured resonant frequency divided by frequency  $f_0$  of a standard dipole of same length. R is radiation resistance in ohms. At A, standard single-wire dipole. At B, two-wire linear-loaded dipole, similar to folded dipole except that side opposite feed line is open. At C, three-wire linear-loaded dipole.



**Fig 39—Two-wire linear-loaded dipole with capacitance end hats.** Main dipole length was constructed from 24 feet of “windowed” ladder line. The end-hat elements were stiff wires 6 feet long. The antenna was strung at about a 60° angle from a tree limb using monofilament fishing line. Measured resonant frequency and radiation resistance were 10.6 MHz and 50 Ω.

lowered the resonant frequency. Six-foot long, single-wire hats were used on each end of the previous 24-foot LLSA, as shown in Fig 39. The antenna was supported in the same way as the previous vertical dipole, but the bottom-end hat wire was only inches from the grass. This system resonated at 10.6 MHz with a measured resistance of 50 Ω.

If the dipole section were lengthened slightly, by a foot or so, to about 25 feet, it should hit the 10.1-MHz band and be a good match for 50-Ω coax. It would be suitable for a restricted space, shortened 30-meter antenna. Note that this antenna is only about half the length of a conventional 30-meter dipole, needs no tuner, and has no losses due to traps. It does have the loss of the extra wire, but this is essentially negligible.

Any of the linear-loaded dipole antennas can be mounted either horizontally or vertically. The vertical version can be used for longer skip contacts—beyond 600 miles or so—unless you have rather tall supports for horizontal antennas to give a low elevation angle. Using different diameter conductors in linear-loaded antenna configurations yields different results, depending on whether the larger or small diameter conductor is fed. NN0F experimented with a vertical ground-plane antenna using a 10-foot piece of electrical conduit pipe (5/8 inch OD) and #12 copper house wire.

Fig 40 shows the configuration. The radial ground system was buried a couple of inches under the soil and is not shown. Note that this is not a folded monopole, which would have either A or B grounded.

The two conductors were separated by 2 inches, using plastic spreaders held onto the pipe by stainless-steel hose clamps obtained from the local hardware store. Hose clamps intertwined at right angles were also used to clamp the pipe on electric fence stand-off insulators on a short 2 × 4 post set vertically in the ground.

The two different diameter conductors make the antenna characteristics change, depending on how they are configured. With the antenna bridge connected to the larger diameter conductor (point A in Fig 40), and point B

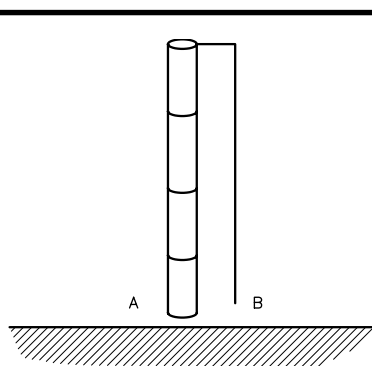


Fig 40—Vertical ground-plane antenna with a 10-foot pipe and #12 wire as the linear-loaded element. Resonant frequency and radiation resistance depend on which side (A or B) is fed. The other side (B or A) is not grounded. See text for details.

unconnected, the system resonated at 16.8 MHz and had  $R = 35 \Omega$ . With the bridge at B (the smaller conductor), and point A left unconnected, the resonance lowered to 12.4 MHz and  $R$  was found to be about 24 Ω.

The resonant frequency of the system in Fig 40 can be adjusted by changing the overall height, or for increasing the frequency, by reducing the length of the wire. Note that a 3.8-MHz resonant ground plane can be made with height only about half that of the usual 67 feet required, if the smaller conductor is fed (point B in Fig 40). In this case, the pipe would be left unconnected electrically. The lengths given above can be scaled to determine a first-try attempt for your favorite band. Resonant lengths will, however, depend on the conductor diameters and spacing.

The same ideas hold for a dipole, except that the lengths should be doubled from those of the ground plane in Fig 40. The resistance will be twice that of the ground plane. Say, how about a shortened 40-meter horizontal beam to enhance your signal?!

### COMBINED LOADING

As an antenna is shortened further the size of the top-loading device will become larger and at some point will be impractical. In this situation inductive loading, usually placed directly between the capacitance “hat” and the top

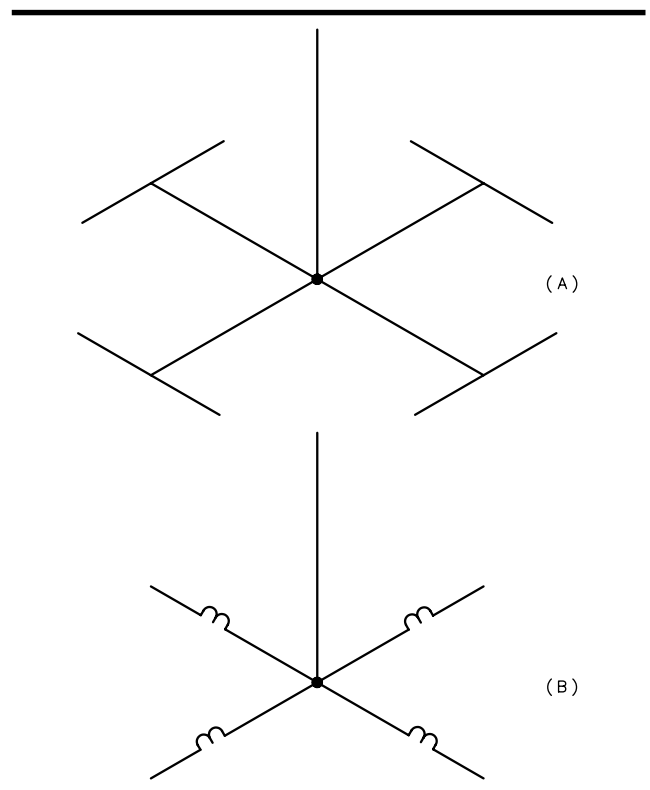


Fig 41—Radials may be shortened by using either capacitive (A) or inductive (B) loading. In extreme cases both may be used but the operating bandwidth will be limited.

of the antenna, can be added to resonate the antenna. An alternative would be to use linear loading in place of inductive loading. The previous section contained an example of end loading combined with linear loading.

### SHORTENING THE RADIALS

Very often the space required by full-length radials is simply not available. Like the vertical portion of the antenna, the radials can also be shortened and loaded in much the same way. An example of end loaded radials is given in Fig 41A. Radials half the usual length can be used with little reduction in efficiency but, as in the case of top loading, the antenna Q will be higher and the bandwidth reduced. As shown in Fig 41B, inductive loading can also be used. As long as they are not made too short (down to  $0.1 \lambda$ ) loaded radials can be efficient—with careful design.

### GENERAL RULES

The steps in designing an efficient short vertical antenna system are:

- Make the vertical section as long as possible
- Make the diameter of the vertical section as large as possible. Tubing or a cage of smaller wires will work well.
- Provide as much top loading as possible
- If the top loading is insufficient, resonate the antenna with a high-Q inductor placed between the hat and the top of the antenna
- For buried-ground systems, use as many radials ( $> 0.2 \lambda$ ) as possible. Forty or more is best
- If an elevated ground plane is used, use 4 to 8 radials, 5 or more feet above ground
- If shortened radials must be used then capacitive loading is preferable to inductive loading

### EXAMPLES OF SHORT VERTICALS

#### A 6-Foot-High 7-MHz Vertical Antenna

Figs 42, 43, 44 and 45 give details for building short, effective vertical quarter-wavelength radiators. This information was originally presented by Jerry Sevick, W2FMI.

A short vertical antenna, properly designed and installed, approaches the efficiency of a full-size resonant quarter-wave antenna. Even a 6-foot vertical on 7 MHz can produce an exceptional signal. Theory tells us that this should be possible, but the practical achievement of such a result requires an understanding of the problems of ground losses, loading, and impedance matching.

The key to success with shortened vertical antennas lies in the efficiency of the ground system with which the antenna is used. A system of at least 60 radial wires is recommended for best results, although the builder may want to reduce the number at the expense of some performance. The radials can be tensioned and pinned at the far ends to permit on-the-ground installation, which will enable the amateur to mow the lawn without the wires becoming entangled in the mower blades. Alternatively, the wires can

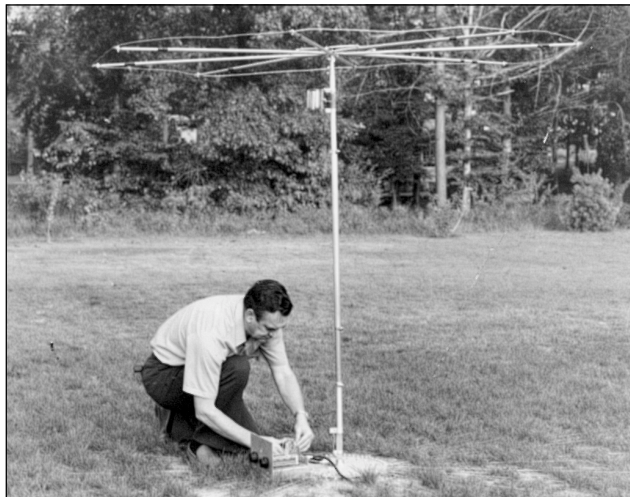


Fig 42—Jerry Sevick, W2FMI, adjusts the 6-foot high, 40-meter vertical.

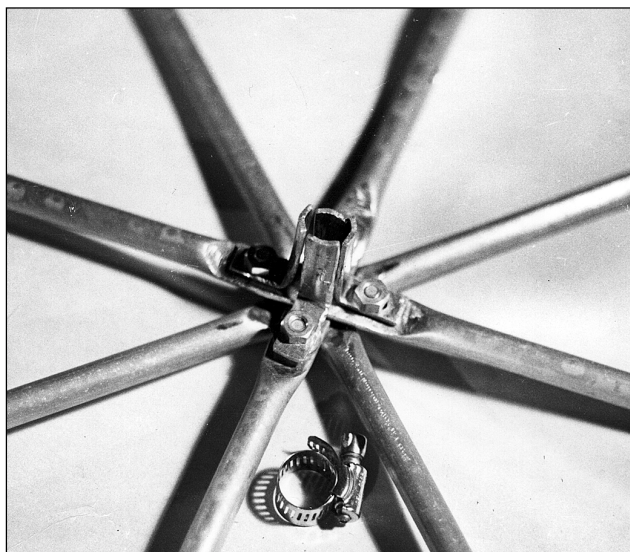


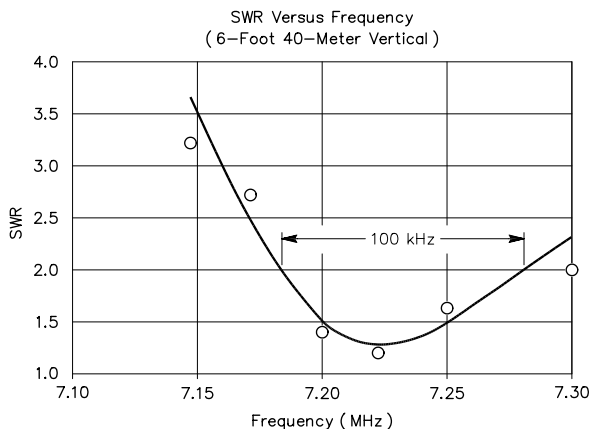
Fig 43—Construction details for the top hat. For a diameter of 7 feet,  $\frac{1}{2}$ -in. aluminum tubing is used. The hose clamp is made of stainless steel and is available at Sears. The rest of the hardware is aluminum.

be buried in the ground, where they will not be visible. There is nothing critical about the wire size for the radials. Radials made of 28, 22, or even 16-gauge wire, will provide the same results. The radials should be at least  $0.2 \lambda$  long (27 feet or greater on 7 MHz).

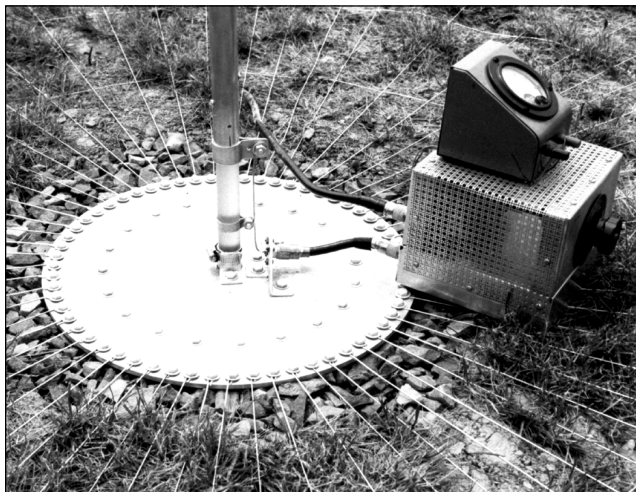
A top hat is formed as illustrated in Fig 43. The diameter is 7 feet, and a continuous length of wire is connected to the spokes around the outer circumference of the wheel. A loading coil consisting of 14 turns of B&W 3029 Miniductor stock ( $2\frac{1}{2}$ -inch dia, 6 TPI, #12 wire) is installed 6 inches below the top hat (see Fig 42). This antenna exhibits a feed-point impedance of  $3.5 \Omega$  at 7.21 MHz. For operation above or below this frequency, the number of coil turns must be decreased or increased, respectively. Matching is

accomplished by increasing the feed-point impedance to  $14 \Omega$  through addition of a 4:1-transformer, then matching  $14 \Omega$  to  $50 \Omega$  (feeder impedance) by means of a pi network. The 2:1 SWR bandwidth for this antenna is approximately 100 kHz.

More than 200 contacts with the 6-foot antenna have indicated the efficiency and capability of a short vertical. Invariably at distances greater than 500 or 600 miles, the short vertical yields excellent signals. Similar antennas can be scaled and constructed for bands other than 7 MHz. The 7-foot-diameter-top hat was tried on a 3.5-MHz vertical, with



**Fig 44—Standing-wave ratio of the 6-foot vertical using a 7-foot top hat and 14 turns of loading 6 inches below the top hat.**



**Fig 45—Base of the vertical antenna showing the 60 radial wires. The aluminum disc is 15 inches in diameter and  $\frac{1}{4}$  inches thick. Sixty tapped holes for  $\frac{1}{4}$ -20 aluminum hex-head bolts form the outer ring and 20 form the inner ring. The inner bolts were used for performance comparisons with more than 60 radials. The insulator is polystyrene material (phenolic or Plexiglas suitable) with a 1-inch diameter. Also shown is the impedance bridge used for measuring input resistance.**

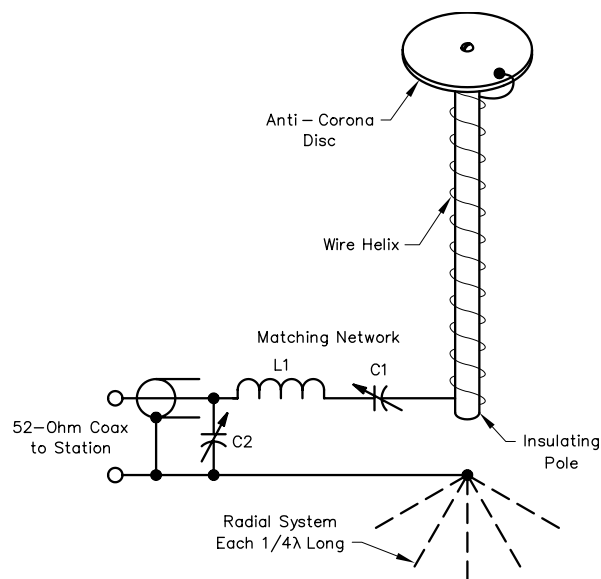
an antenna height of 22 feet. The loading coil had 24 turns and was placed 2 feet below the top hat. On-the-air results duplicated those on 40 meters. The bandwidth was 65 kHz.

Short verticals such as these have the ability to radiate and receive almost as well as a full-size quarter-wave. Trade-offs are in lowered input impedances and bandwidths. With a good radial system and a proper design, these trade-offs can be made entirely acceptable.

### Short Continuously Loaded Verticals

While there is the option of using lumped inductance to achieve resonance in a short antenna, the antenna can also be helically wound to provide the required inductance. This is shown in **Fig 46**. Shortened quarter-wavelength vertical antennas can be made by forming a helix on a long cylindrical insulator. The diameter of the helix must be small in terms of  $\lambda$  to prevent the antenna from radiating in the axial mode.

Acceptable form diameters for HF-band operation are from 1 inch to 10 inches when the practical aspects of antenna construction are considered. Insulating poles of fiberglass, PVC tubing, treated bamboo or wood, or phenolic are suitable for use in building helically wound radiators. If wood or bamboo is used the builder should treat the material with at least two coats of exterior spar varnish prior to winding the antenna element. The completed structure should be given



**Fig 46—Helically wound ground-plane vertical. Performance from this type of antenna is comparable to that of many full-size  $\lambda/4$  vertical antennas. The major design trade-off is usable bandwidth. All shortened antennas of this variety are narrow-band devices. At 7 MHz, in the example illustrated here, the bandwidth between the 2:1 SWR points will be on the order of 50 kHz, half that amount on 80 meters, and twice that amount on 20 meters. Therefore, the antenna should be adjusted for operation in the center of the frequency band of interest.**

two more coats of varnish, regardless of the material used for the coil form. Application of the varnish will help weatherproof the antenna and prevent the coil turns from changing position.

No strict rule has been established concerning how short a helically wound vertical can be before a significant drop in performance is experienced. Generally, one should use the greatest amount of length consistent with available space. A guideline might be to maintain an element length of 0.05 wavelength or more for antennas which are electrically a quarter wavelength long. Thus, use 13 feet or more of stock for an 80-meter antenna, 7 feet for 40 meters, and so on.

A quarter-wavelength helically wound vertical can be used in the same manner as a full-size vertical. That is, it can be worked against an above-ground wire radial system (four or more radials), or it can be ground-mounted with radials buried or lying on the ground. Some operators have reported good results when using antennas of this kind with four helically wound radials cut for resonance at the operating frequency. The latter technique should capture the attention of those persons who must use indoor antennas.

### Winding Information

There is no hard-and-fast formula for determining the amount of wire needed to establish resonance in a helical antenna. The relationship between the length of wire needed for resonance and a full quarter wave at the desired frequency depends on several factors. Some of these are wire size, diameter of the turns, and the dielectric properties of the form material, to name a few. Experience has indicated that a section of wire approximately one half wavelength long, wound on an insulating form with a linear pitch (equal spacing between turns) will come close to yielding a resonant quarter wavelength. Therefore, an antenna for use on 160 meters would require approximately 260 feet of wire, spirally wound on the support.

No specific rule exists concerning the size or type of wire one should use in making a helix. Larger wire sizes are, of course, preferable in the interest of minimizing I<sup>2</sup>R losses in the system. For power levels up to 1000 watts it is wise to use a wire size of #16 or larger. Aluminum clothesline wire is suitable for use in systems where the spacing between turns is greater than the wire diameter. Antennas requiring close-spaced turns can be made from enameled magnet wire or #14 vinyl jacketed, single-conductor house wiring stock. Every effort should be made to keep the turn spacing as large as is practical to maximize efficiency.

A short rod or metal disc should be made for the top or high-impedance end of the vertical. This is a necessary part of the installation to assure reduction in antenna Q. This broadens the bandwidth of the system and helps prevent extremely high amounts of RF voltage from being developed at the top of the radiator. (Some helical antennas act like Tesla coils when used with high-power transmitters, and can actually catch fire at the high-impedance end when a stub or disc is not used.) Since the Q-lowering device exhibits

some additional capacitance in the system, it must be in place before the antenna is tuned.

### Tuning and Matching

Once the element is wound it should be mounted where it will be used, with the ground system installed. The feed end of the radiator can be connected temporarily to the ground system. Use a dip meter to check the antenna for resonance by coupling the dipper to the last few turns near the ground end of the radiator. Add or remove turns until the vertical is resonant at the desired operating frequency.

It is impossible to predict the absolute value of feed impedance for a helically wound vertical. The value will depend upon the length and diameter of the element, the ground system used with the antenna, and the size of the disc or stub atop the radiator. Generally speaking, the radiation resistance will be very low—approximately 3 to 10 Ω. An L network of the kind shown in Fig 46 can be used to increase the impedance to 50 Ω. The Q<sub>L</sub> (loaded Q) of the network inductors is low to provide reasonable bandwidth, consistent with the bandwidth of the antenna. Network values for other operating bands and frequencies can be determined by using the reactance values listed below. The design center for the network is based on a radiation resistance of 5 Ω. If the exact feed impedance is known, the following equations can be used to determine precise component values for the matching network. (See Chapter 25 for additional information on L-network matching.)

$$X_A = QR_L \quad (\text{Eq 7})$$

$$X_{C2} = 50 \sqrt{\frac{R_L}{50 - R_L}} \quad (\text{Eq 8})$$

$$X_{L1} = X_{C1} + \frac{R_L 50}{X_{C2}} \quad (\text{Eq 9})$$

where

X<sub>C1</sub> = capacitive reactance of C1

X<sub>C2</sub> = capacitive reactance of C2

X<sub>L1</sub> = inductive reactance of L1

Q = loaded Q of network

R<sub>L</sub> = radiation resistance of antenna

Example: Find the network constants for a helical antenna with a feed impedance of 5 Ω at 7 MHz, Q = 3:

$$X_{C1} = 3 \times 5 = 15$$

$$X_{C2} = \sqrt{\frac{5}{50 - 5}} = 16.666$$

$$X_{L1} = 15 + \frac{250}{16.666} = 30$$

Therefore, C1 = 1500 pF, C2 = 1350 pF, and L1 = 0.7 μH. The capacitors can be made from parallel or series combinations of transmitting micas. L1 can be a few turns of large Mininductor stock. At RF power levels of 100 W or less, large compression trimmers can be used at C1 and C2

because the maximum RMS voltage at 100  $\Omega$  (across 50  $\Omega$ ) will be 50 V. At, say, 800 W there will be approximately 220 V RMS developed across 50  $\Omega$ . This suggests the use of small transmitting variables at C1 and C2, possibly connected in parallel with fixed values of capacitance to constitute the required amount of capacitance for the network.

By making some part of the network variable, it will be possible to adjust the circuit for an SWR of 1:1 without knowing precisely what the antenna feed impedance is. Actually, C1 is not required as part of the matching network. It is included here to bring the necessary value for L1 into a practical range.

Fig 46 illustrates the practical form a typical helically wound ground-plane vertical might take. Performance from this type antenna is comparable to that of many full-size quarter-wavelength vertical antennas. The major design trade-off is in usable bandwidth. All shortened antennas of this variety are narrow-band devices. At 7 MHz, in the example illustrated here, the bandwidth between the 2:1 SWR points will be on the order of 50 kHz, half that amount on 80 meters, and twice that amount on 20 meters. Therefore, the antenna should be adjusted for operation in the center of the frequency spread of interest.

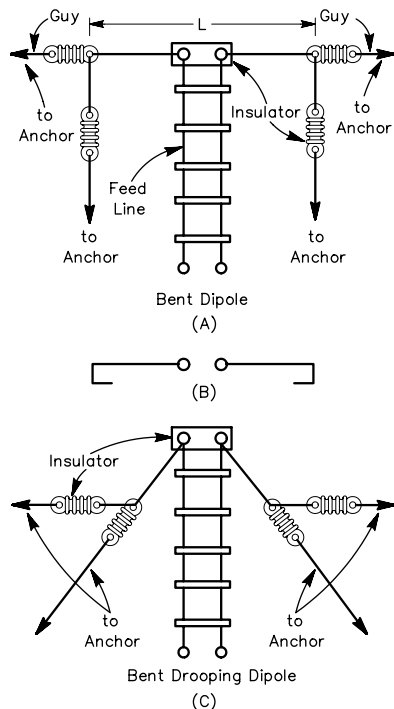


Fig 47—When space is limited, the ends may be bent downward as shown at A, or back on the radiator as shown at B. The bent dipole ends may come straight down or be led off at an angle away from the center of the antenna. An inverted V at C can be erected with the ends bent parallel to the ground when the support structure is not high enough.

## SHORTENED DIPOLES

As shown in preceding sections, there are several ways to load antennas so they may be reduced in size without severe reduction in effectiveness. Loading is always a compromise; the best method is determined by the amount of space available and the band(s) to be worked.

The simplest way to shorten a dipole is shown in Fig 47. If you do not have sufficient length between the supports, simply hang as much of the center of the antenna as possible between the supports and let the ends hang down. The ends can be straight down or may be at an angle as indicated but in either case should be secured so that they do not move in the wind. As long as the center portion between the supports is at least  $\lambda/4$ , the radiation pattern will be very nearly the same as a full-length dipole.

The resonant length of the wire will be somewhat shorter than a full-length dipole and can best be determined by experimentally adjusting the length of ends, which may be conveniently near ground. Keep in mind that there can be very high potentials at the ends of the wires and for safety the ends should be kept out of reach. Letting the ends hang down as shown is a form of capacitive end loading. While it is efficient, it will also reduce the matching bandwidth—as does any form of loading.

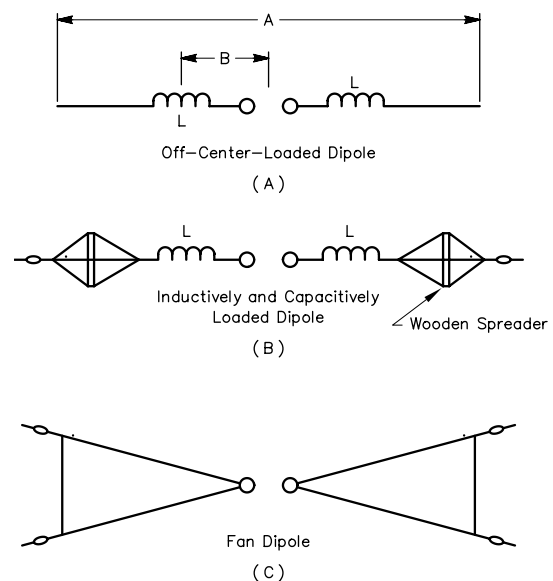
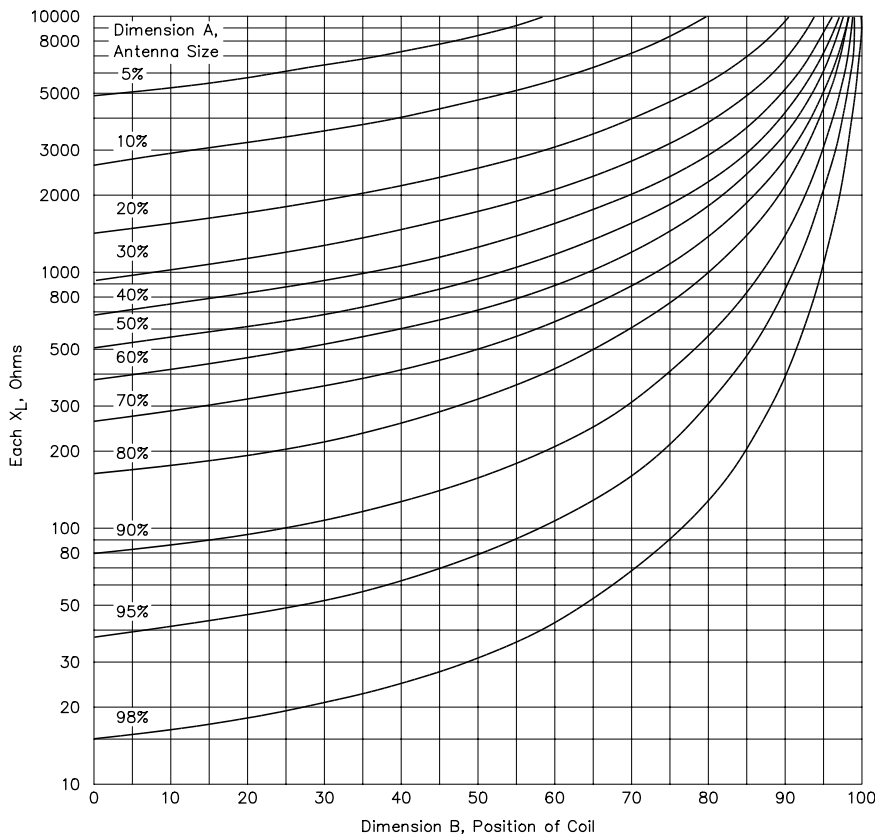


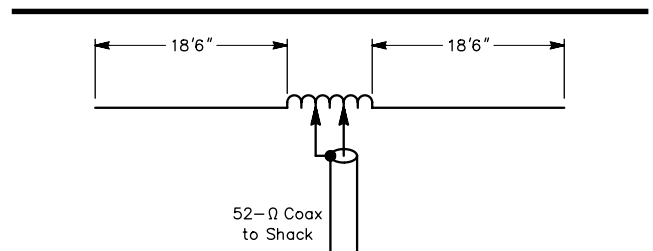
Fig 48—At A is a dipole antenna lengthened electrically with off-center loading coils. For a fixed dimension A, greater efficiency will be realized with greater distance B, but as B is increased, L must be larger in value to maintain resonance. If the two coils are placed at the ends of the antenna, in theory they must be infinite in size to maintain resonance. At B, capacitive loading of the ends, either through proximity of the antenna to other objects or through the addition of capacitance hats, will reduce the required value of the coils. At C, a fan dipole provides some electrical lengthening as well as broadbanding.



**Fig 49—Chart for determining approximate inductance values for off-center-loaded dipoles. See Fig 48A. At the intersection of the appropriate curve from the body of the chart for dimension A and proper value for the coil position from the horizontal scale at the bottom of the chart, read the required inductive reactance for resonance from the scale at the left. Dimension A is expressed as percent length of the shortened antenna with respect to the length of a half-wave dipole of the same conductor material. Dimension B is expressed as the percentage of coil distance from the feed point to the end of the antenna. For example, a shortened antenna, which is 50% or half the size of a half-wave dipole (one-quarter wavelength overall) with loading coils positioned midway between the feed point and each end (50% out), would require coils having an inductive reactance of approximately 950 Ω at the operating frequency for antenna resonance.**

The most serious drawback associated with inductive loading is high loss in the coils themselves. It is important that you use inductors made from reasonably large wire or tubing to minimize this problem. Close winding of turns should also be avoided if possible. A good compromise is to use some off-center inductive loading in combination with capacitive end loading, keeping the inductor losses small and the efficiency as high as possible.

Some examples of off-center coil loading and capacitive-end loading are shown in Fig 48. This technique was described by Jerry Hall, K1TD in Sep 1974 QST. For the antennas shown, the longer the overall length (dimension A, Fig 48A) and the farther the loading coils are from the center of the antenna (dimension B), the greater the efficiency of the antenna. As dimension B is increased, however, the inductance required to resonate the antenna at the desired frequency increases. Approximate inductance values for single-band resonance (for the antenna in Fig 48A only) may be determined with the aid of Fig 49 or from Eq 10 below. The final values will depend on the proximity of surrounding objects in individual installations and must be determined experimentally. The use of high-Q low-loss coils is important for maximum efficiency.



**Fig 50—The W0SVM “Shorty Forty” center-loaded antenna. Dimensions given are for 7.0 MHz. The loading coil is 5 inches long and 2½ inches diameter. It has a total of 30 turns of #12 wire wound at 6 turns per inch (Miniductor 3029 stock).**

$$X_L = \frac{10^6}{34\pi f} \left[ \frac{\left( \ln \frac{24 \left( \frac{234}{f} - B \right)}{D} - 1 \right) \left( \left( 1 - \frac{fB}{234} \right)^2 - 1 \right)}{\frac{234}{f} - B} - \frac{\left( \ln \frac{24 \left( \frac{A}{2} - B \right)}{D} - 1 \right) \left( \left( \frac{fA}{2} - fB \right)^2 - 1 \right)}{\frac{A}{2} - B} \right] \quad (\text{Eq 10})$$



A dip meter or SWR indicator is recommended for use during adjustment of the system. Note that the minimum inductance required is for a center-loaded dipole. If the inductive reactance is read from Fig 49 for a dimension B of

zero, one coil having approximately twice this reactance can be used near the center of the dipole. Fig 50 illustrates this idea. This antenna was conceived by Jack Sobel, W0SVM, who dubbed the 7-MHz version the “Shorty Forty.”

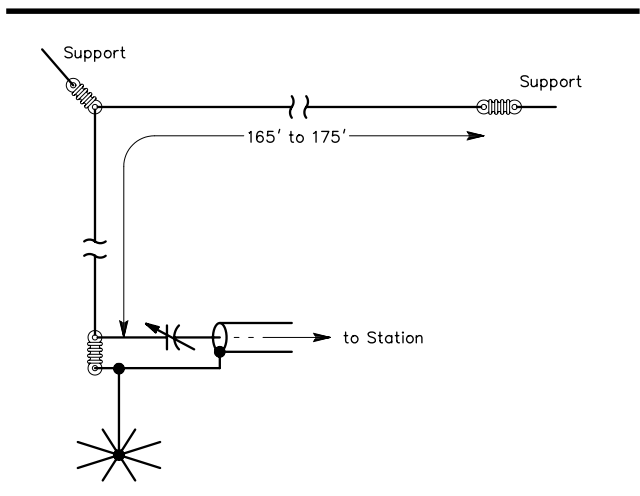
## Inverted-L Antennas

The antenna shown in Fig 51 is called an *inverted-L* antenna. It is simple and easy to construct and is a good antenna for the beginner or the experienced 1.8-MHz DXer. Because the overall electrical length is made somewhat greater than  $\lambda/4$ , the feed-point resistance is on the order of  $50 \Omega$ , with an inductive reactance. That reactance is canceled by a series capacitor as indicated in the figure. For a vertical section length of 60 feet and a horizontal section length of 125 feet, the input impedance is  $\approx 40 + j 450 \Omega$ . Longer vertical or horizontal sections would increase the input impedance. The azimuthal radiation pattern is slightly asymmetrical with  $\approx 1$  to 2 dB increase in the direction

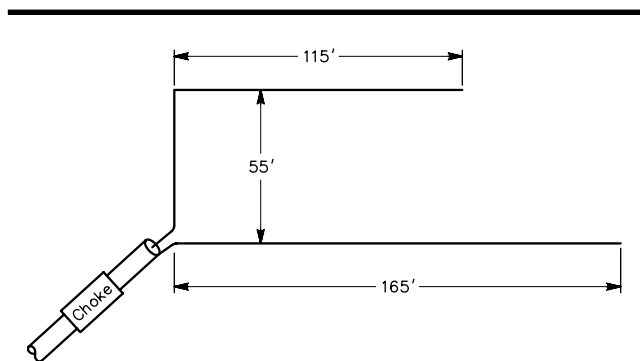
opposite to the horizontal wire. This antenna requires a good buried ground system or elevated radials.

This antenna is a form of top-loaded vertical, where the top loading is asymmetrical. This results in both vertical and horizontal polarization because the currents in the top wire do not cancel like they would in a symmetrical-T vertical. This is not necessarily a bad thing because it eliminates the zenith null present in a true vertical. This allows for good communication at short ranges as well as for DX.

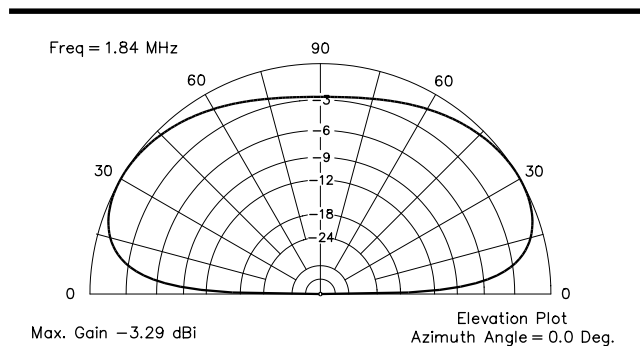
A yardarm attached to a tower or a tree limb can be used to support the vertical section. As with any vertical,



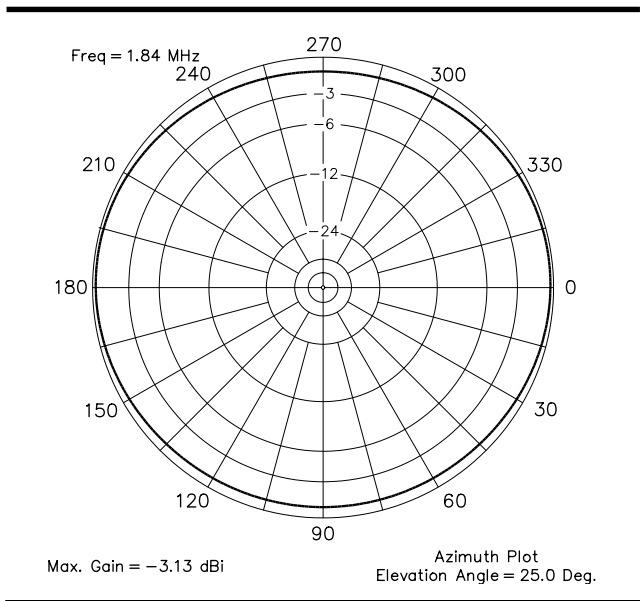
**Fig 51—The 1.8-MHz inverted L. Overall wire length is 165 to 175 feet. The variable capacitor has a maximum capacitance of 500 to 800 pF. Adjust antenna length and variable capacitor for lowest SWR.**



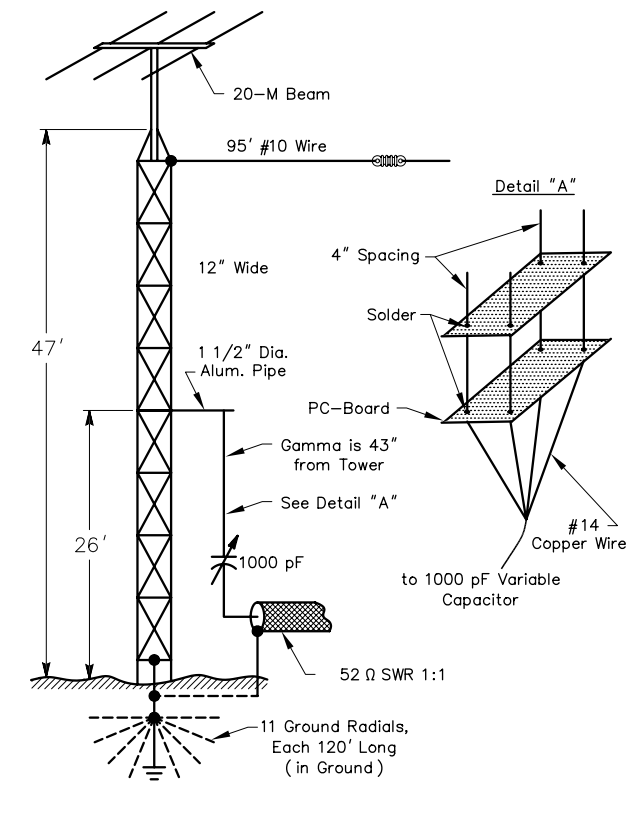
**Fig 52—A single elevated radial can be used for the inverted L. This changes the directivity slightly.**



**Fig 53—Elevation pattern for the inverted L with a single radial.**



**Fig 54—Azimuthal pattern for the inverted L with a single radial at an elevation angle of 25°.**



**Fig 55—Details and dimensions for gamma-match feeding a 50-foot tower as a 1.8-MHz vertical antenna. The rotator cable and coaxial feed line for the 14-MHz beam is taped to the tower legs and run into the shack from ground level. No decoupling networks are necessary.**

for best results the vertical section should be as long as possible. A good ground system is necessary for good results—the better the ground, the better the results.

If the ground system suggested for Fig 51 is not practical, it is possible to use a single elevated radial as shown in Fig 52. For the dimensions shown in the figure  $Z_i = 50 + j 465 \Omega$ . The vertical and azimuthal radiation patterns are shown in Figs 53 and 54. Note that the 1 to 2 dB asymmetry is now in the direction of the horizontal wires, just the opposite of that for a symmetrical ground system.

### A Different Approach

Fig 55 shows the method used by Doug DeMaw, W1FB, to gamma match his self-supporting 50-foot tower operating as an inverted L. A wire cage simulates a gamma rod of the proper diameter. The tuning capacitor is fashioned from telescoping sections of 1 1/2 and 1 1/4-inch aluminum tubing with polyethylene tubing serving as the dielectric. This capacitor is more than adequate for power levels of 100 watts. The horizontal wire connected to the top of the tower provides the additional top loading.

## Sloper Antennas

Sloping dipoles and  $\lambda/2$  dipoles can be very useful antennas on the low bands. These antennas can have one end attached to a tower, tree or other structure and the other end near ground level. The following section gives a number of examples of these types of antennas.

### THE QUARTER-WAVELENGTH “HALF SLOPER”

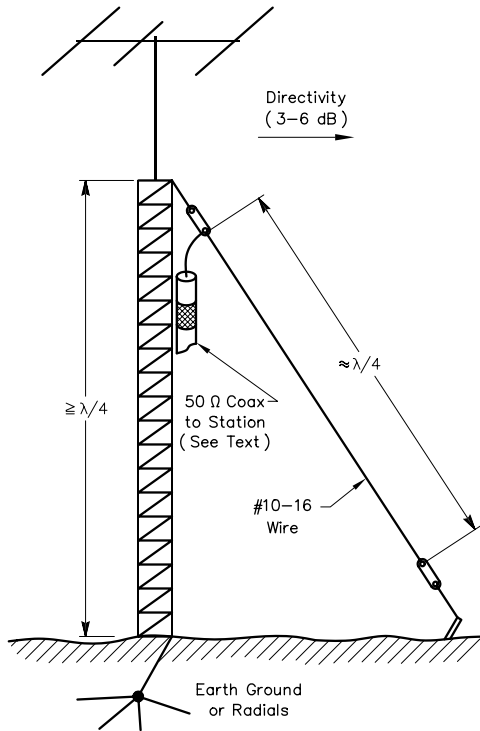
Perhaps one of the easiest antennas to install is the  $\lambda/4$  sloper shown in Fig 56. A sloping  $\lambda/2$  dipole is known among radio amateurs as a “full sloper” or just “sloper.” If only one half of it is used it becomes a “half sloper.” The performance of the two types of sloping antennas is similar: They exhibit some directivity in the direction of the slope and radiate energy at low angles relative to the horizon. The wave polarization is vertical. The amount of directivity will range from 3 to 6 dB, depending upon the individual installation, and will be observed in the slope direction. A typical radiation pattern is given in Fig 57.

The advantage of the half sloper over the full sloper is that the current portion of the antenna is higher. Also, only half as much wire is required to build the antenna for a given

amateur band. The disadvantage of the half sloper is that it is sometimes impossible to obtain a low SWR when using coaxial-cable feed, especially without a good isolating choke balun. (See the section above on isolating ground-plane antennas.) Other factors that affect the feed impedance are tower height, height of the attachment point, enclosed angle between the sloper and the tower, and what is mounted atop the tower (HF or VHF beams). Also the quality of the ground under the tower (ground conductivity, radials, etc) has a marked effect on the antenna performance. The final SWR can vary (after optimization) from 1:1 to as high as 6:1. Generally speaking, the closer the low end of the slope wire is to ground, the more difficult it will be to obtain a good match.

### Basic Recommendations for Half Sloper

The half sloper can be an excellent DX type of antenna. It is usually installed on a metal supporting structure such as a mast or tower. The support needs to be grounded at the lower end, preferably to a buried or on-ground radial system. If a nonconductive support is used, the outside of the coax braid becomes the return circuit and should be grounded at



**Fig 56—The  $\lambda/4$  “half sloper” antenna.**

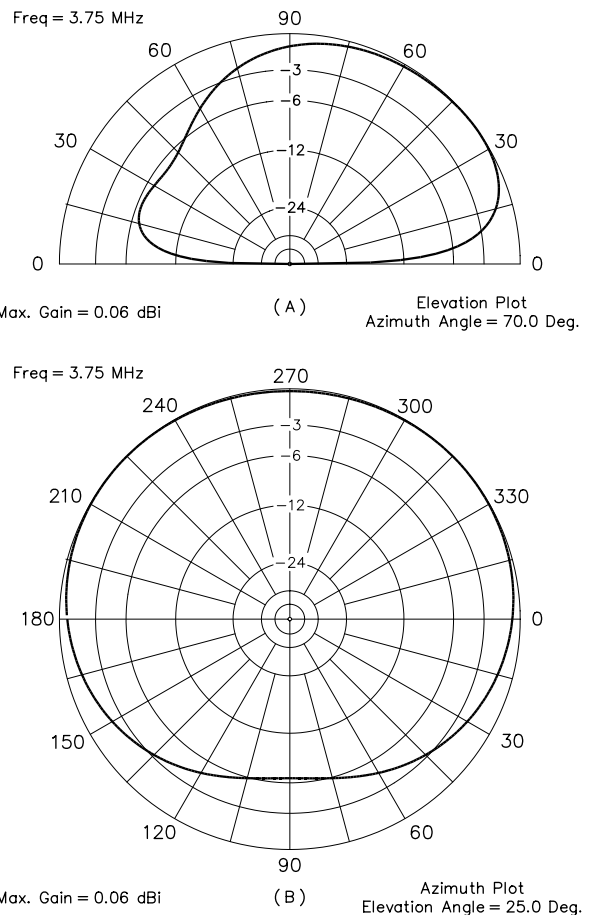
the base of the support. As a starting point one can attach the sloper so the feed point is approximately  $\lambda/4$  above ground. If the tower is not high enough to permit this, the antenna should be fastened as high on the supporting structure as possible. Start with an enclosed angle of approximately  $45^\circ$ , as indicated in Fig 56. The wire may be cut to the length determined from

$$\ell = \frac{260}{f_{\text{MHz}}} \quad (\text{Eq 11})$$

This will allow sufficient extra length for pruning the wire for the lowest SWR. A metal tower or mast becomes an operating part of the half sloper system. In effect, it and the slope wire function somewhat like an inverted-V dipole antenna. In other words, the tower operates as the missing half of the dipole. Hence its height and the top loading (beams) play a significant role.

The 50- $\Omega$  transmission line can be taped to the tower leg at frequent intervals to make it secure. The best method is to bring it to earth level, then route it to the operating position along the surface of the ground if it can't be buried. This will ensure adequate RF decoupling, which will help prevent RF energy from affecting the equipment in the station. Rotator cable and other feed lines on the tower or mast should be treated in a similar manner.

Adjustment of the half sloper is done with an SWR indicator in the 50- $\Omega$  transmission line. A compromise can be found between the enclosed angle and wire length, providing the lowest SWR attainable in the center of the



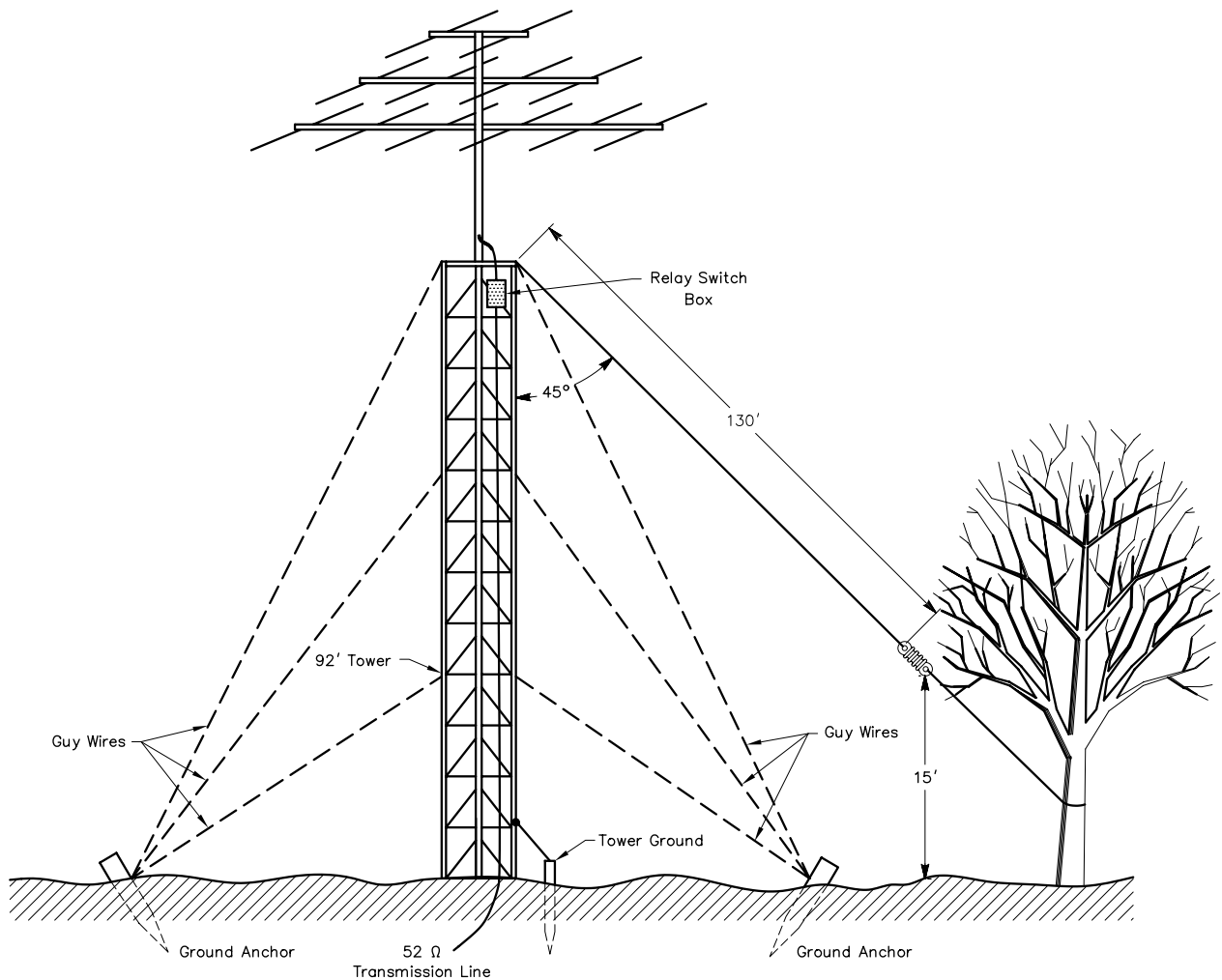
**Fig 57—Radiation pattern for a typical half sloper. At A, elevation pattern. At B, azimuth pattern.**

chosen part of an amateur band. If the SWR “bottoms out” at 2:1 or lower, the system will work fine without using an antenna tuner, provided the transmitter can work into the load. Typical optimum values of SWR for 3.5 or 7-MHz half slopers are between 1.3:1 and 2:1. A 100-kHz bandwidth is normal on 3.5 MHz, with 200 kHz being typical at 7 MHz.

If the lowest SWR possible is greater than 2:1, the attachment point can be raised or lowered to improve the match. Readjustment of the wire length and enclosed angle may be necessary when the feed-point height is changed. If the tower is guyed, the guy wires will need to be insulated from the tower and broken up with additional insulators to prevent resonance.

### 1.8-MHz ANTENNA SYSTEMS USING TOWERS

An existing metal tower used to support HF or VHF beam antennas can also be used as an integral part of a 1.8-MHz radiating system. The half sloper discussed earlier will also perform well on 1.8 MHz. Prominent 1.8-MHz operators who have had success with the half sloper antenna suggest a minimum tower height of 50 feet. Dana Atchley, W1CF, used the configuration sketched in Fig 58. He reported that the uninsulated guy wires act as an effective



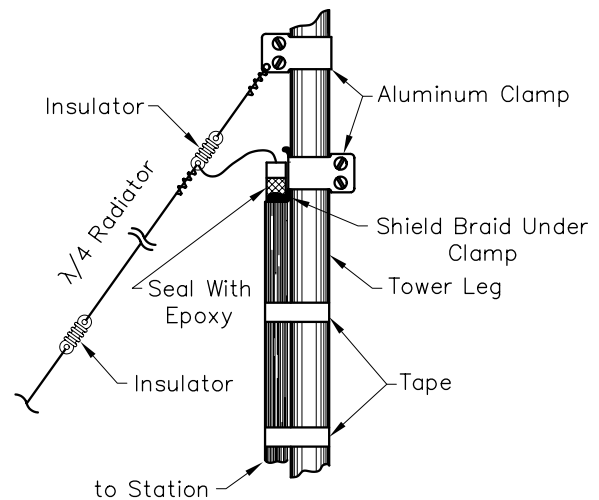
**Fig 58—The W1CF half sloper for 160 meters is arranged in this manner. Three monoband antennas atop the tower provide capacitive loading.**

counterpoise for the sloping wire. At Fig 59 is the feed system used by Doug DeMaw, W1FB, on a 50-foot self-supporting tower. The ground for the W1FB system is provided by buried radials connected to the tower base.

As described previously, a tower can also be used as a true vertical antenna, provided a good ground system is used. The shunt-fed tower is at its best on 1.8 MHz, where a full  $\lambda/4$  vertical antenna is rarely possible. Almost any tower height can be used. An HF beam at the top provides some top loading.

### 7-MHz "SLOPER SYSTEM"

One of the more popular antennas for 3.5 and 7 MHz is the half-wave long sloping dipole. David Pietraszewski, K1WA, made an extensive study of sloping dipoles at different heights with reflectors at the 3-GHz frequency range. From his experiments, he developed the novel 7-MHz antenna system described here. With several sloping dipoles supported by a single mast and a switching network, an antenna with directional characteristics and forward gain



**Fig 59—Feed system used by W1FB for 1.8 MHz half sloper on a 50-foot self-supporting tower.**

can be simply constructed. This 7-MHz system uses several “slopers” equally spaced around a common center support. Each dipole is cut to  $\lambda/2$  and fed at the center with 50- $\Omega$  coax. The length of each feed line is 36 feet.

All of the feed lines go to a common point on the support (tower) where the switching takes place. The line length of 36 feet is just over  $3\lambda/8$ , which provides a useful quality. At 7 MHz, the coax looks inductive to the antenna when the end at the switching box is open circuited. This has the effect of adding inductance at the center of the sloping dipole element, which electrically lengthens the element. The 36-foot length of feed line serves to increase the length of the element about 5%. This makes any unused element appear to be a reflector.

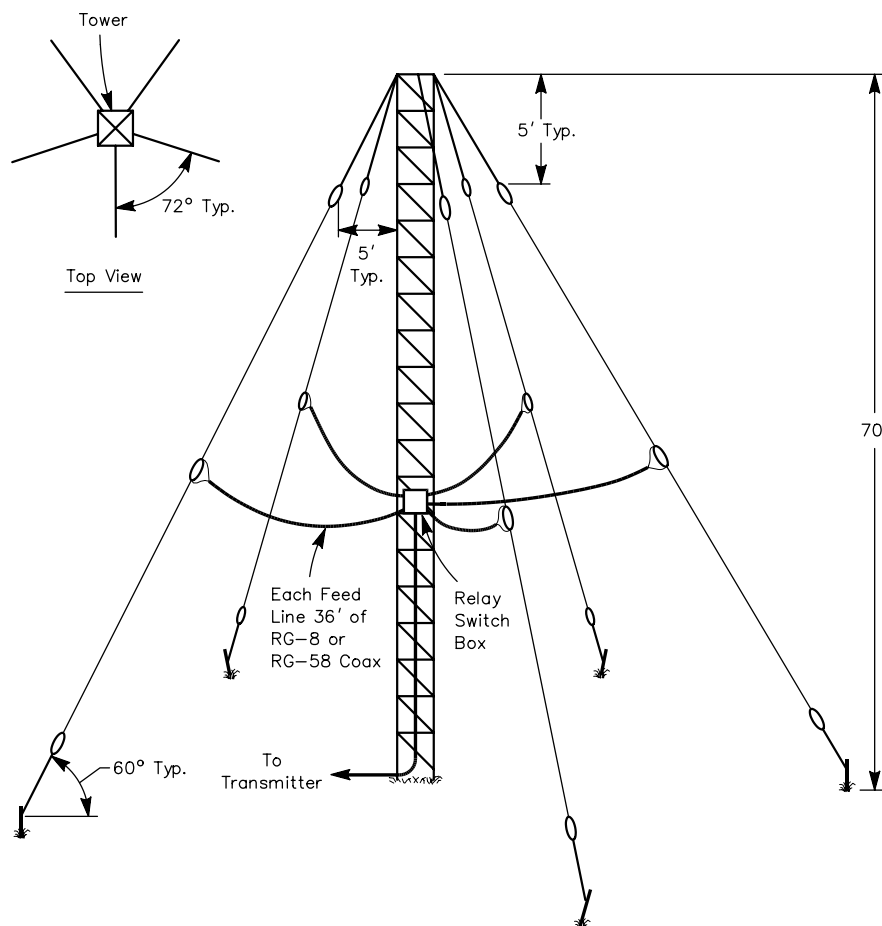
The array is simple and effective. By selecting one of the slopers through a relay box located at the tower, the system becomes a parasitic array that can be electrically rotated. All but the driven element of the array become reflectors.

The physical layout is shown in **Fig 60**, and the basic materials required for the sloper system are shown in **Fig 61**. The height of the support point should be about

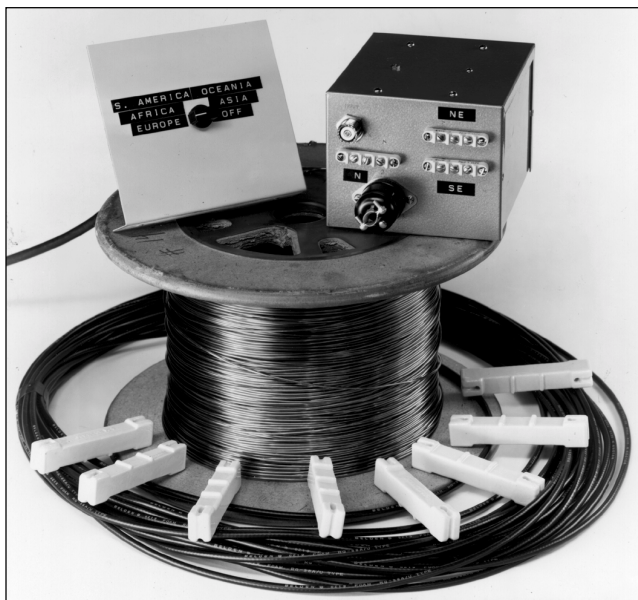
70 feet, but can be less and still give reasonable results. The upper portion of the sloper is 5 feet from the tower, suspended by rope. The wire makes an angle of  $60^\circ$  with the ground.

In **Fig 62**, the switch box is shown containing all the necessary relays to select the proper feed line for the desired direction. One feed line is selected at a time and the feed lines of those remaining are opened, **Fig 63**. In this way the array is electrically rotated. These relays are controlled from inside the shack with an appropriate power supply and rotary switch. For safety reasons and simplicity, 12-volt dc relays are used. The control line consists of a five-conductor cable, one wire used as a common connection; the others go to the four relays. By using diodes in series with the relays and a dual-polarity power supply, the number of control wires can be reduced, as shown in **Fig 63B**.

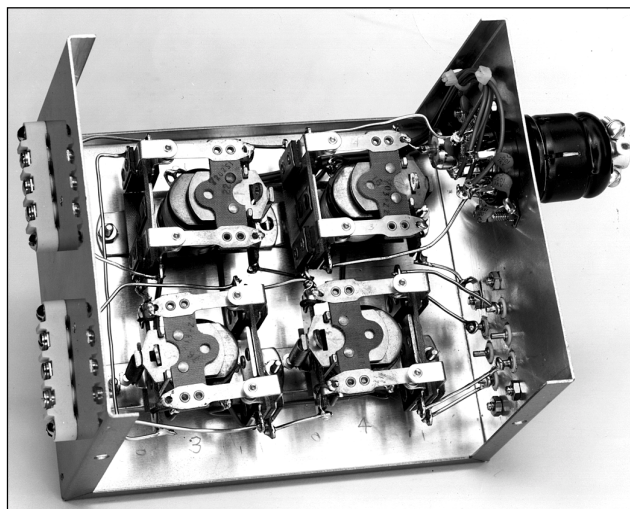
Measurements indicate that this sloper array provides up to 20 dB front-to-back ratio and forward gain of about 4 dB over a single half-wave sloper. If one direction is the only concern, the switching system can be eliminated and the reflectors should be cut 5% longer than the resonant frequency. The one feature worth noting is the good F/B ratio.



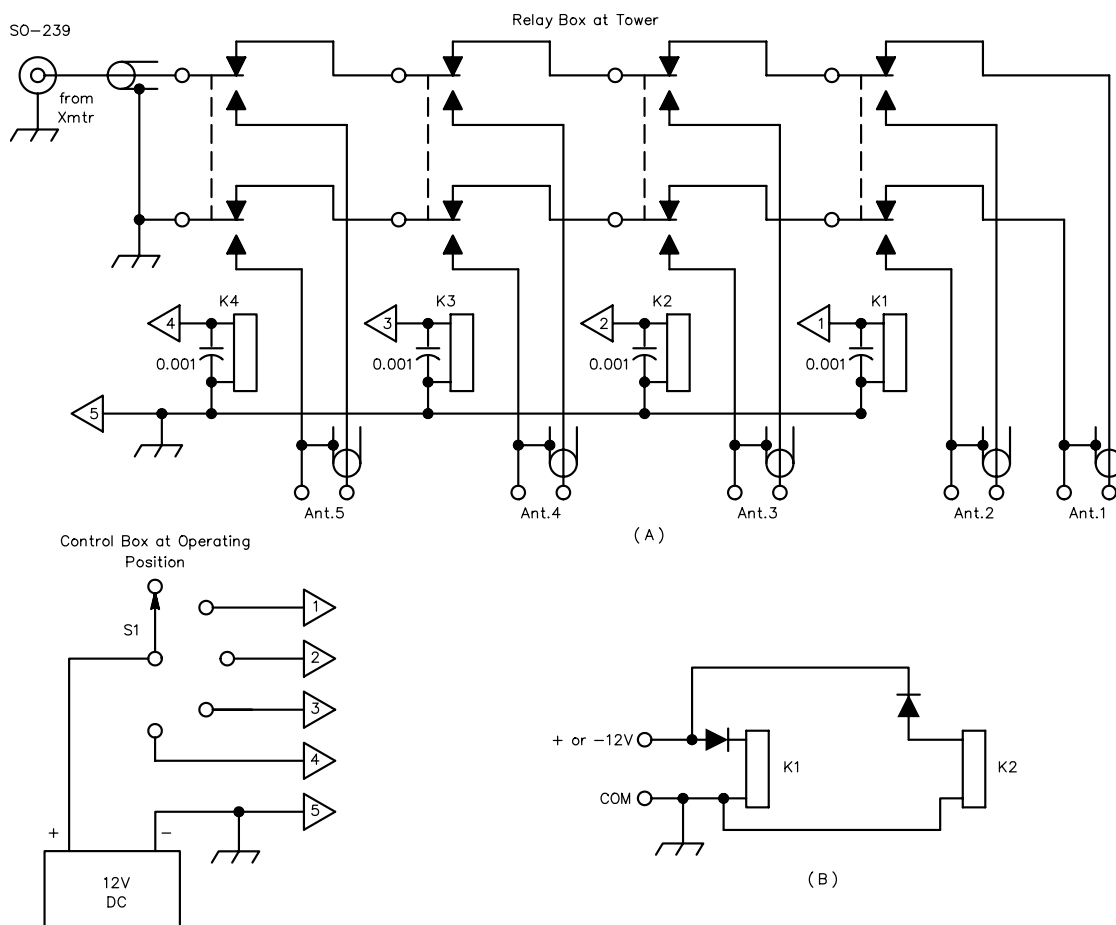
**Fig 60**—Five sloping dipoles suspended from one support. Directivity and forward gain can be obtained from this simple array. The top view shows how the elements should be spaced around the support.



**Fig 61**—The basic materials required for the sloper system. The control box appears at the left, and the relay box at the right.



**Fig 62**—Inside view of relay box. Four relays provide control over five antennas. See text. The relays pictured here are Potter and Brumfeld type MR11D.



**Fig 63**—Schematic diagram for sloper control system. All relays are 12-volt dc, DPDT, with 8-A contact ratings. At A, the basic layout, excluding control cable and antennas. Note that the braid of the coax is also open-circuited when not in use. Each relay is bypassed with 0.001- $\mu$ F capacitors. The power supply is a low current type. At B, diodes are used to reduce the number of control wires when using dc relays. See text.

By arranging the system properly, a null can be placed in an unwanted direction, thus making it an effective receiving antenna. In the tests conducted with this antenna, the number of reflectors used were as few as one and as many as five.

The optimum combination appeared to occur with four reflectors and one driven element. No tests were conducted with more than five reflectors. This same array can be scaled to 3.5 MHz for similar results.

## Low-Frequency (“Lowfer”) Antennas

The following section on low-frequency antennas is from material submitted by Andrew Corney, ZL2BBJ, and Bob Vernall, ZL2CA, and material from Curry Communications.

The *Low Frequency* band (known commonly as the *lowfer* band) ranges from 30 to 300 kHz, or in terms of wavelength from 10,000 to 1000 meters. Allocation of specific LF bands varies from one region of the world to another. For example, in the US the lowfer allocation is from 160 to 190 kHz, and the band is commonly referred to as 1750 meters.

The long wavelengths of LF bands introduce real challenges for amateur antennas. A frequency of 200 kHz corresponds to a wavelength of 1500 meters, where a full-sized  $\lambda/4$  vertical would be about 375 meters (1230 feet) high!

In the US, FCC regulations limit the antenna to a cylindrical area 50 feet high, with a diameter of 50 feet. This essentially restricts US lowfer antennas to top-loaded verticals, since a loop with those dimensions is not very practical. In terms of wavelength, a 15-meter high vertical is only 0.0086  $\lambda$  high on 1750 meters, putting it into the category of a *really tiny* antenna! The FCC also limits power input to the antenna to 1 watt.

### ELECTRICALLY SMALL ANTENNAS

The impedance of electrically tiny antennas is highly reactive (capacitive for whips, inductive for loops), since they are too small to have any natural resonance. While any small antenna can be resonated by loading with inductance (or capacitance for a loop), antenna and ground losses overshadow whatever power is radiated to the far field. For amateur LF antennas, radiation resistance is conveniently expressed in milliohms, rather than ohms. The overall efficiency of an amateur LF antenna is unlikely to exceed 1%. In fact, 0.1% is a more realistic target for amateur LF antennas in suburban locations. Nevertheless, even 0.1% efficiency can achieve useful communication over several hundred kilometers.

### LF PROPAGATION CHARACTERISTICS

Contrasted with HF, the surface wave at LF is a very important propagation mode. Even at 1.8 MHz in the Medium Frequency (MF) spectrum, attenuation of the ground wave is relatively high, rendering the surface ground wave far less useful than at LF.

Surprisingly little radiated power can provide effective

LF communication over hundreds of kilometers. At 180 kHz, 1 mW of radiated power will enable a CW signal to be copied at a range of 400 km over sea or good ground, and 300 km over poor ground, assuming a daytime noise level of about -10 dB re 1  $\mu$ V/m in a 500-Hz bandwidth.

Daytime signals are remarkably steady in strength, providing good conditions for SSB, where 10 mW radiated power can be copied comfortably at 300 km over a seawater path or good ground. Daytime conditions are likely to favor specialized computer-controlled modes using low information rates, which promise much greater ranges than are possible with conventional CW.

During the night, skywave propagation by ionospheric reflection generally dominates the surface wave for reception over longer distances. The skywave is strongly attenuated during daylight hours, but around sunset attenuation usually decreases. This results in progressive increases in DX signal strength, reaching a maximum four to six hours after sunset. The skywave is actually a mixture of waves resulting from different ionospheric-reflection mechanisms. The multipath nature of these means that they interfere with each other and with the ground wave to produce a random pattern of signal enhancements followed by deep fades. An enhancement will typically last several minutes, and similarly fading is generally slow.

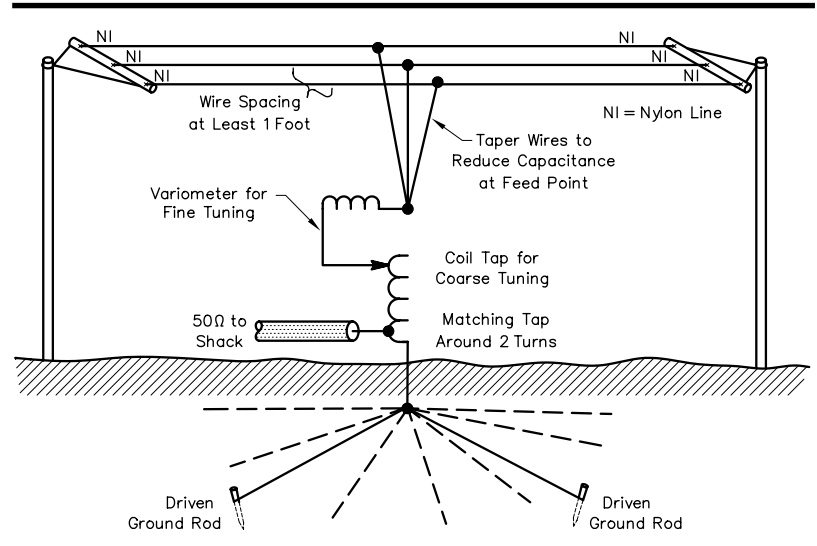
Night-time DX signal strengths are generally much stronger than during the day. However, as night-time atmospheric noise tends to rise in sympathy with the sky-wave strength, there is less benefit from enhanced night-time propagation than we might expect. Nevertheless, the greatest communication ranges using conventional CW are usually achieved one or two hours after sunset at the mid point of a path. Fortunately there are some occasions when skywaves are favorable and QRN is lower than normal, the combination of which leads to DX opportunities.

### POLARIZATION FOR LF

The conductivity of most types of ground means that vertically polarized LF waves can propagate relatively unhindered as surface ground waves. Higher ground conductivity leads to lower propagation loss. On the other hand, horizontally polarized waves have an electric field component parallel to the conducting surface of the ground. This effectively “shorts out” the electric field, resulting in higher losses for horizontal polarization.

There is little choice in the matter—LF transmitting antennas must be vertically polarized. Even for sky-wave

**Fig 64—An idealized lower vertical-T antenna. A base loading coil with a variometer for fine-tuning is used, along with capacitance-hat top-loading wires. Note that three vertical wires are used to increase the bandwidth and that the performance gets better with more top-loading wires to increase the top capacitance. The ground-radial system consists of as many wires as possible, buried a few inches below the surface.**



propagation (with its random polarization of received signals due to ionospheric reflections) a ground-mounted LF antenna responds mainly to the vertical component.

### LF TRANSMITTING ANTENNAS

Often an existing HF or MF wire antenna can be put to use on LF. L and T antennas were popular in the early days of LF radio transmission, and the principles still apply. If there are regulatory limits on the overall size of an LF antenna (as in the US), then a vertical with inductive center loading, with or without top loading, is the most suitable choice for making the most of a size-limited situation.

A top-loaded system, such as a T, is preferable to a straight coil-loaded vertical, since it can give a considerable increase in efficiency compared to a simple vertical of the same height. For a T antenna, the radiated power is proportional to the square of the “effective height.” The current in a vertical with no top loading tapers linearly from maximum at the bottom to zero at the top, and has an effective height of half the physical height of the antenna. The more top loading used, the higher the current at the top of the vertical section. With “infinite” capacitive top loading, the effective height is equal to the physical height, giving a four-fold increase in efficiency.

Multiple top loading wires and multiple ground radial wires (usually bare copper wire) buried just below ground level are highly recommended. Multiple earth rods can also be used to advantage, such as being connected to the far ends of radial wires, but are probably not as useful as adding more radial wires.

For estimating the capacitance of a T antenna made of wires, an approximation is to use 6 pF per meter for vertical wires, and 5 pF per meter for horizontal wires. When multiple close-spaced wires are used, proximity effect will reduce the net capacitance to less than if individual wires were summed in capacitance. For additional details on capacitance

top-hat loading, especially multi-spoked “wagon wheel” structures, see discussion earlier in this chapter.

A low-loss (high-Q) base loading coil is needed to resonate the vertical at the operating frequency. The coil shape should have a diameter to length ratio of about 2.5 for highest Q (which is different from the optimum shape for HF inductors). Turns should be spaced by about one wire diameter. Tuning is fairly critical, and a variometer (some series turns on a spindle inside the loading coil) can be very handy for fine tuning.

### The ZL2CA LF Transmitting Antenna

See Fig 64 for information on an ideal type of LF vertical for amateur use. In most cases amateurs will need to adapt the ideal to suit the practicalities of a given QTH. A top-loaded T antenna is used by ZL2CA for operation in the vicinity of 180 kHz. It is not a large antenna, but performs reasonably well. The vertical feed is near the middle of the property, and rises some 8 meters to a horizontal fiberglass rod mounted near the top of a pipe mast that is also used for mounting other antennas. The fiberglass rod provides good insulation and keeps the vertical feed wire a meter or so away from the grounded pipe mast. It also terminates all top-loading wires.

Top-loading wires at ZL2CA go in various directions, customized to fit on the particular property. The loading system toward the rear of the property is actually a horizontal 40-meter delta loop. The corner feed point can be manually changed from a coax balun (balanced feed in HF mode) to a single wire coming from the fiberglass standoff (unbalanced feed in LF mode). The delta loop feed point is on the pipe mast near the fiberglass standoff used for LF, and is accessible by ladder. The other two poles supporting the delta loop are some 10 meters high. Top-loading wires toward the front of the property make up a fan of six wires, varying in length from 11 to 17 meters. There is a seventh



**Table 8**  
**Measured Impedance at the Bottom of ZL2CA's T Antenna**

<i>Frequency (kHz)</i>	<i>Resistance (<math>\Omega</math>)</i>	<i>Capacitance (pF)</i>
100	14	790
165	11	800
190	10	805
250	9	810
300	8	815

wire running across the far end of the fan to support the fan wires at an average of around 9 meters above ground.

The ground system consists of 13 bare copper radials running to various parts of the property, and several of these have a driven-pipe earth at the far end. The measured values of the impedance at the bottom of the vertical wire are shown in **Table 8**. The antenna is self-resonant around 1.4 MHz and is useful on 160 meters as well as LF. The resistance measured between the RF earth and mains earth is 4.1  $\Omega$ . The earth resistance probably varies with soil moisture. Some of the antenna top loading is galvanized wire, and this may contribute to the RF resistance of the antenna. However, the lower resistance with increasing frequency in the above table suggests it is not a major factor. The loading coil used has a Q of just over 300, which adds some 3  $\Omega$  in series with the overall loop resistance.

The antenna vertical wire is taken from a carefully selected point around 57 turns on the loading coil. The loaded Q of the whole antenna is about 60, so tuning is critical. Matching to 50- $\Omega$  coaxial cable is by tapping 2 turns from the "cold" end of the loading coil. An alternative is an L match consisting of 30 nF of polypropylene capacitors between coax inner and ground, with the series inductance of some 20  $\mu$ H in effect being a small part of the loading coil. The matching bandwidth of the antenna is satisfactory for SSB.

An estimate of radiation resistance at 180 kHz is 10 milliohms, giving an efficiency of 0.08% (the net series resistance is some 13  $\Omega$ ). Applying 100 watts results in about 2.7 amps of antenna current, and a radiated power of up to 80 mW. The voltage applied from the loading coil to the antenna is about 6000 volts. It is difficult to know the specific radiated power, but whatever it is, it provides a lot of fun for chasing DX when propagation conditions are good. This has resulted in logging two-way CW contacts to 670 km and two-way SSB contacts to 460 km. SSB has been monitored at distances to 700 km.

### Other Transmitting Antenna Types

Some lowfers in the US use helically wound short verticals, with top-hat loading, such as are described in some detail earlier in this chapter. They use three 10-foot sections of 2-inch diameter white PVC pipe. The three sections are

coupled together with wood dowels and are wound with #22 wire spaced evenly along each section, where the turns are spaced by diameter of the wire. Solder lugs are bolted to each end of each section to connect to the wire. Once the three sections are joined together to make up the 30-foot long radiator, wire jumpers are soldered across adjoining lugs. The final antenna must be pruned for resonance.

### Loops

The top-loaded vertical antenna is almost always the best choice for an amateur LF transmitting antenna. (In fact it is virtually the only choice in the US due to FCC regulations.) Another possible alternative outside the US is some form of loop. However, a top-loaded vertical in a suburban backyard will have a much higher radiation resistance than can be achieved by a loop antenna in the same space, and the directional properties of the loop are usually more of a hindrance than a help.

### INSULATION FOR TRANSMITTING ANTENNAS

High voltages are present on the antenna and feeders during LF transmission. Especially for a loaded vertical antenna, the whole antenna system is subject to much higher voltages than in typical HF antennas. Adequate insulators are needed at every support point on any LF transmitting antenna. Egg-type insulators are generally not up to the task, especially when they are wet. Leakage paths across insulators should be as long as practical.

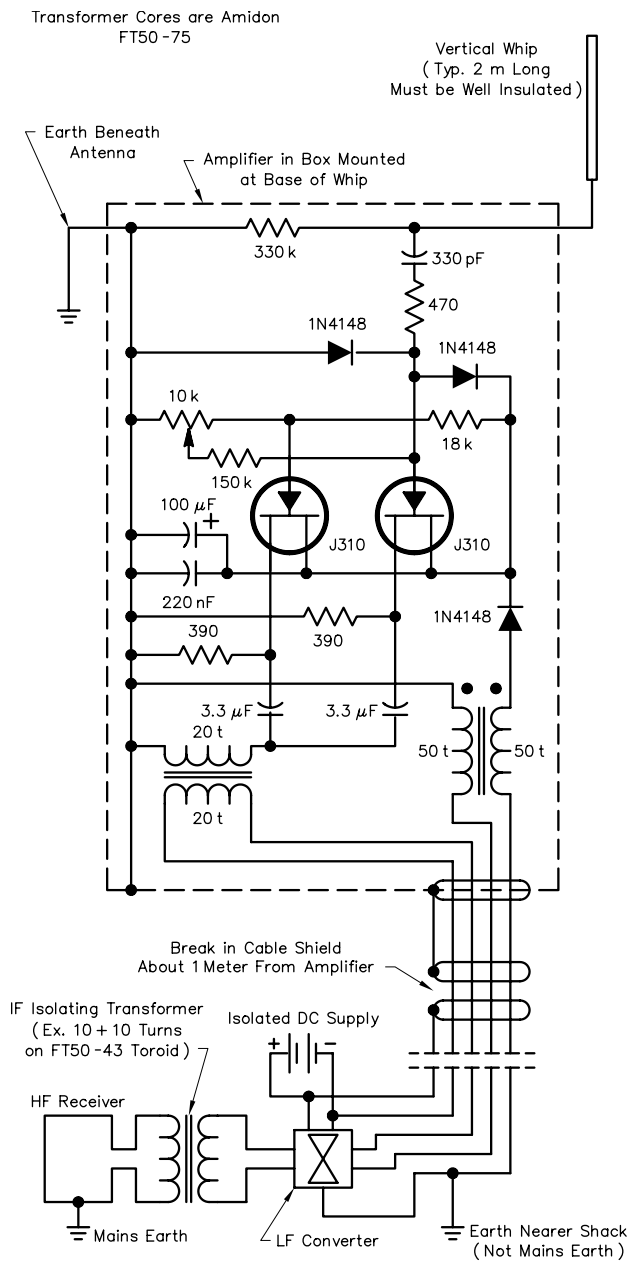
Monofilament nylon (otherwise known as heavy duty fishing line) provides cheap and very effective insulation for LF antennas. It is also visually unobtrusive. The length of a nylon line insulator can be as long as is convenient, and the smooth surface is washed clean in the rain. The life of monofilament nylon insulators is approximately five years, depending on wind conditions and ultraviolet radiation levels.

The feeder to an LF antenna will generally need to exit either the cabinet of a tuner box or go through the shack wall, so very good feedthrough insulation should be provided. Plastic tubing can be used to sleeve a feeder wire that passes through a feedthrough hole in a wall. Several layers of plastic tubing can be applied by using appropriately selected diameters. If arcing is suspected, it can be monitored with a nearby VHF receiver, and it should soon be obvious if arcing occurs during LF transmission. It is hard enough to radiate a small amount of power at LF, so wasting power on unwanted discharges must be avoided!

Base insulators can be very simple. Some use a glass soft-drink bottle held in a hollow cinder block on the ground. An old-fashioned "Coke" bottle makes a great insulator!

### LF RECEIVING ANTENNAS

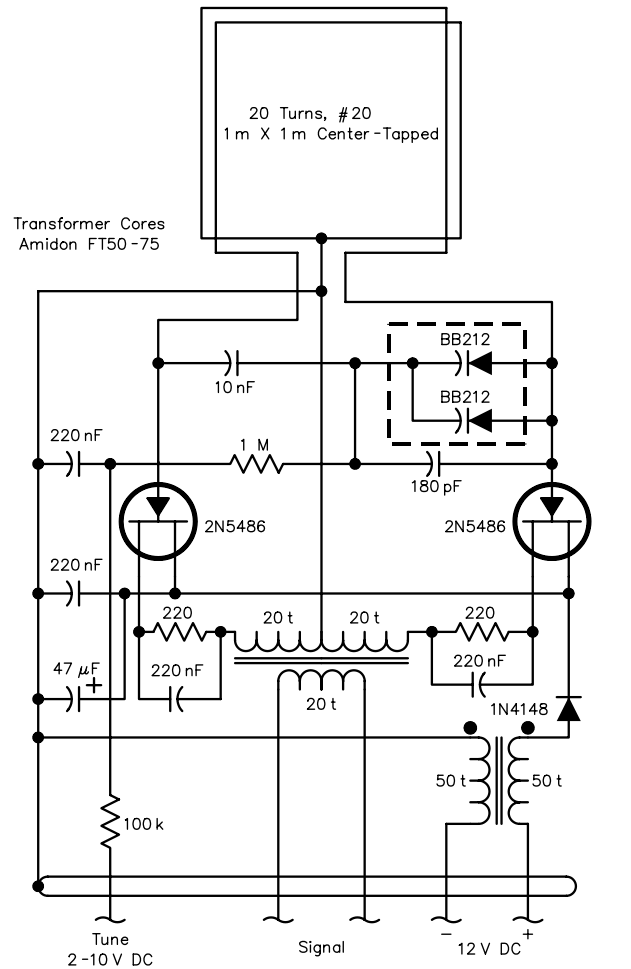
Receiving LF signals is generally much easier than transmitting LF signals. Electrical noise from thunderstorms travels vast distances, establishing a background atmospheric noise that greatly exceeds the receiver thermal noise. Inefficient receiving antennas are tolerable as long as they



**Fig 65—Remote active lower preamplifier. Note that careful attention must be paid to ground isolation for best S/N.**

can still hear the background noise. Man-made radio noise is usually a more serious limitation in most suburban situations, as the electricity mains conduct “hash” around the neighborhood. Switching-mode power supplies in domestic appliances such as PCs are one of the more obnoxious noise sources.

At LF, local noise is spread more by being conducted by mains electrical wiring, rather than by radiation. An LF transmitting antenna often couples rather well to the near field of mains wiring, giving the LF band an undeserved reputation as being excessively noisy. A dramatic improvement can result from using a small active antenna



**Fig 66—Remote active preamplifier for directional loop receiving antenna.**

located a modest distance (20 feet or more) away from any building supplied with mains power. The small aperture of the active antenna reduces coupling to the mains wiring without sacrificing far-field reception, provided the very high impedance of the small antenna is properly matched to the receiver with a low-noise-figure buffer amplifier.

It is also very important to prevent mains interference from reaching the antenna by the cable from the receiver to the antenna by decoupling the cable using chokes and/or isolating transformers. The active-antenna power supply should also be well decoupled from the mains. It is also very important to detune the transmitting antenna while receiving, to prevent noise picked up by the large antenna from coupling into the receive antenna. This coupling can occur over a surprisingly long distance.

Cable decoupling is particularly important for an active vertical antenna, **Fig 65**, where the buffer amplifier is grounded directly beneath the antenna, and isolated from common-mode cable interference by means of a transformer to isolate the signal and a bifilar choke to isolate the power

supply. The JFET buffer amplifier used to match the very high antenna impedance to the low cable impedance must have a low noise figure, together with a high second-order intermodulation threshold to prevent interference from strong AM broadcast signals.

The type of FET used is important, the J310 being one of the more satisfactory. Two FETs in parallel increase the second order threshold by 6 dB. Input filtering may still be needed if the antenna is within a few kilometers of high-power broadcast and television stations. It is not commonly appreciated that the voltage induced by LF and MF signals is proportional to the average height of the antenna above ground, rather than to the length of the antenna. Even a small antenna mounted high up may pick up enough AM broadcast signals to overload the antenna.

A remotely tuned receiving loop having a performance limited by natural noise (external QRN) is shown in Fig 66. A smaller loop is satisfactory for nighttime use but will not have a good enough noise figure for daytime work, when noise levels are much lower. A larger loop with fewer turns will work well if it is not too near mains wiring. A balanced unshielded loop is easier to construct than a shielded loop and rejects electric fields just as well. This is important if the signals from an active loop and active vertical are to be combined in a manner similar to that used in direction-finding, which can give a signal-to-noise improvement of 2 dB. This does not sound impressive but can make all the difference in whether or not a weak signal can be copied.

## LF ANTENNA TEST EQUIPMENT

High permeability ferrite cores must be used at LF for current transformers and directional wattmeters. Ferrite cores salvaged from surplus TV line output transformers are very useful. An inline RF current monitor with the antenna feed passing through the core (equivalent to a single turn primary) is an effective way of sampling antenna current. The secondary can be 20 to 30 turns, loaded with 27  $\Omega$ , and a simple diode feeding a low-current meter through a suitable range resistor. The current monitor can even be calibrated against an RF thermocouple ammeter. If the monitor is at the high-voltage end of a vertical antenna loading coil, take care to ensure that adequate insulation is present around the antenna feed passing through the toroidal core.

Many amateurs use even simpler instrumentation. Three NE-2 neon bulbs in series placed near the antenna serve as a very useful indicator of tuning, although they can be a little hard to see in direct sunlight.

When a new antenna is erected it is useful to know the capacitance in the case of a vertical, or the inductance in the case of a loop, so that matching circuits can be designed. An audio component bridge will give an answer that is fairly close to the LF capacitance value, provided precautions are taken against mains pickup overloading the bridge detector. Another method is to use a signal generator and oscilloscope to find the resonant frequency with a known inductance for a vertical. This method also enables the loss component to

be estimated from the observed Q.

Comparative before-and-after tests on transmitting antenna effectiveness following a hoped-for improvement (for example, more top loading or better earth system) can be made by measuring the open-circuit voltage from a navigation beacon. The open-circuit voltage is directly proportional to the effective height of the antenna, and any improvement in effective height means an improvement in efficiency. One way of obtaining a relative open-circuit voltage measurement is to couple the antenna to an LF receiver through a capacitor of a few picofarads. Of course, the coupling capacitor should not be disturbed between changes to the system.

## SAFETY PRECAUTIONS

While amateurs can have a lot of fun with RF experimentation at LF, there are important safety precautions required for transmitting antennas. Most LF antennas are resonant arrangements, with relatively high Q, and high RF voltages are present. There should be no possibility of humans or animals coming into contact with exposed feeders or antenna wires. All insulation material should be very good. Although the power radiated into the far field is minute, the near fields in the close vicinity of an LF antenna can be intense enough to exceed the electromagnetic field exposure limits applying in some countries. The antenna should not be energized if people are close to any of the conductors.

## BIBLIOGRAPHY

Source material and more extended discussion of topics covered in this chapter can be found in the references given below.

- D. Atchley, Jr., "Putting the Quarter-Wave Sloper to Work on 160," *QST*, Jul 1979, pp 19-20.
- J. Belrose, "Transmission Line Low Profile Antennas," *QST*, Dec 1975, pp 19-25.
- L. Braskamp, AA6GL, "MOBILE, a Computer Program for Short HF Verticals," *The ARRL Antenna Compendium Vol 4*, pp 92-96.
- G. H. Brown, "The Phase and Magnitude of Earth Currents Near Radio Transmitting Antennas," *Proc. IRE*.
- G. H. Brown, R. F. Lewis and J. Epstein, "Ground Systems as a Factor in Antenna Efficiency," *Proc. IRE*, Jun 1937, pp 753-787.
- P. Carr, N4PC, "A Two Band Half-Square Antenna With Coaxial Feed," *CQ*, Sep 1992, pp 40-45.
- P. Carr, N4PC, "A DX Antenna For 40 Meters," *CQ*, Sep 1994, pp 40-43.
- A. Christman, KB8I, "Elevated Vertical Antennas for the Low Bands," *The ARRL Antenna Compendium Vol 5*, pp 11-18.
- Curry Communications, PO Box 1884, Burbank, CA 91507, a kit manufacturer of lower CW transceivers.
- D. DeMaw, "Additional Notes on the Half Sloper," *QST*, Jul 1979, pp 20-20.
- P. Dodd, *The LF Experimenter's Source Book* (RSGB, 1996).
- A. C. Doty, Jr., J. A. Frey and H. J. Mills, "Efficient Ground

- Systems for Vertical Antennas,” *QST*, Feb 1983, pp 9-12.
- R. Fosberg, “Some Notes on Ground Systems for 160 Meters,” *QST*, Apr 1965, pp 65-67.
- J. Hall, “Off-Center-Loaded Dipole Antennas,” *QST*, Sep 1974, pp 28-34.
- G. Hubbell, “Feeding Grounded Towers as Radiators,” *QST*, pp 32-33, 140, 142.
- P. H. Lee, *The Amateur Radio Vertical Antenna Handbook*, 1st edition (Port Washington, NY: Cowan Publishing Corp., 1974).
- C. J. Michaels, “Some Reflections on Vertical Antennas,” *QST*, July 1987, pp 15-19; feedback *QST*, Aug 1987, p 39.
- Rashed and C. Tai, “A New Class of Wire Antennas,” 1982 International Symposium Digest, *Antennas and Propagation*, Vol 2, IEEE.
- T. Russell, N4KG, “Simple, Effective, Elevated Ground-Plane Antennas,” *QST*, June 1994, pp 45-46
- F. J. Schnell, “The Flagpole Deluxe,” *QST*, Mar 1978, pp 29-32.
- R. Severns, N6LF, “Using the Half-Square Antenna for Low-Band DXing,” *The ARRL Antenna Compendium Vol 5*, pp 35-42.
- R. Severns, N6LF, “Broadbanding the Half-Square Antenna For 80-meter DXing,” *The ARRL Antenna Compendium Vol 5*, pp 43-44.
- R. Severns, N6LF, “An Improved Double Extended Zepp,” *The ARRL Antenna Compendium Vol 4*, pp 78-80.
- J. Sevick, “The Ground-Image Vertical Antenna,” *QST*, Jul 1971, pp 16-19, 22.
- J. Sevick, “The W2FMI Ground-Mounted Short Vertical,” *QST*, Mar 1973, pp 13-18, 41.
- J. Sevick, “The Constant-Impedance Trap Vertical,” *QST*, Mar 1974, pp 29-34.
- J. Sevick, “Short Ground-Radial Systems for Short Verticals,” *QST*, Apr 1978, pp 30-33.
- J. Sevick, W2FMI, *Transmission Line Transformers*, Noble Publishing, Atlanta, 1996, p 9-28.
- W. Smith, W6BCX, “Bet My Money On A Bobtail Beam,” *CQ*, Mar 1948, pp 21-23, 92.
- J. Stanford, NN0F, “Linear-Loaded Short Wire Antennas,” *The ARRL Antenna Compendium, Vol 5*, pp 105-107.
- J. Swank, W8HXR, “The S-Meter Bender,” *73*, Jun 1978, pp 170-173.
- J. Tyskewicz, “The Heli-Rope Antenna,” *QST*, Jun 1971.
- B. Vester, K3BC, “The Half-Square Antenna,” *QST*, Mar 1974, pp 11-14.
- A. D. Watt, *VLF Radio Engineering* (Pergamon Press, 1967) (out of print).
- Prediction of Sky-wave Field Strength at Frequencies Between About 150 and 1700 kHz*, ITU Doc 3/14, Radiocommunication Study Groups, Feb 1995.
- Vertical Antenna Classics* (ARRL, 1995)

# Multiband Antennas

For operation in a number of bands, such as those between 3.5 and 30 MHz, it would be impractical for most amateurs to put up a separate antenna for each band. But this is not necessary—a dipole, cut for the lowest frequency band to be used, can be operated readily on higher frequencies. To do so, one must be willing to accept the fact that such harmonic-type operation leads to a change in the directional pattern of the antenna (see [Chapter 2](#)). The user must also be willing to use so-called *tuned feeders*. A center-fed single-wire antenna can be made to accept power and radiate it with high efficiency on any frequency higher than its fundamental resonant frequency and, with a reduction in efficiency and bandwidth, on frequencies as low as one half the fundamental.

In fact, it is not necessary for an antenna to be a full half-wavelength long at the lowest frequency. An antenna can be considerably shorter than  $\frac{1}{2} \lambda$ , even as short as  $\frac{1}{4} \lambda$ , and still be a very efficient radiator. The use of such short

antennas results in stresses, however, on other parts of the system, for example the antenna tuner and the transmission line. This will be discussed in some detail in this chapter.

Methods have been devised for making a single antenna structure operate on a number of bands while still offering a good match to a transmission line, usually of the coaxial type. It should be understood, however, that a multiband antenna is not *necessarily* one that will match a given line on all bands where you intend to use it. Even a relatively short whip type of antenna can be operated as a multiband antenna with suitable loading for each band. Such loading may be in the form of a coil at the base of the antenna on those frequencies where loading is needed, or it may be incorporated in the tuned feeders running from the transmitter to the base of the antenna.

This chapter describes a number of systems that can be used on two or more bands. Beam antennas, such as [Yagis](#) or [quads](#), are treated separately in later chapters.

## Simple Wire Antennas

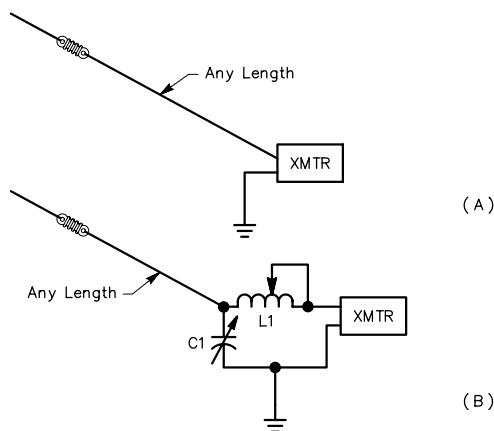
The simplest multiband antenna is a random length of #12 or #14 wire. Power can be fed to the wire on practically any frequency using one or the other of the methods shown in [Fig 1](#). If the wire is made either 67 or 135 feet long, it can also be fed through a tuned circuit, as in [Fig 2](#). It is advantageous to use an SWR bridge or other indicator in the coax line at the point marked “X.”

If a 28- or 50-MHz rotary beam has been installed, in many cases it may be possible to use the beam feed line as an antenna on the lower frequencies. Connecting the two wires of the feeder together at the station end will give a random-length wire that can be conveniently coupled to the transmitter as in [Fig 1](#). The rotary system at the far end will serve only to *end-load* the wire and will not have much other effect.

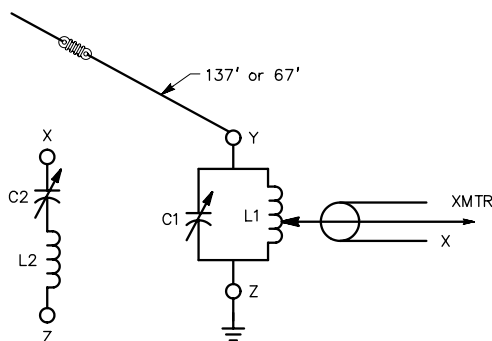
One disadvantage of all such directly fed systems is that part of the antenna is practically within the station, and there is a good chance that you will have some trouble with RF feedback. RF within the station can often be minimized by choosing a length of wire so that the low feed-point

impedance at a current loop occurs at or near the transmitter. This means using a wire length of  $\lambda/4$  (65 feet at 3.6 MHz, 33 feet at 7.1 MHz), or an odd multiple of  $\lambda/4$  ( $3/4\lambda$  is 195 feet at 3.6 MHz, 100 feet at 7.1 MHz). Obviously, this can be done for only one band in the case of even harmonically related bands, since the wire length that presents a current loop at the transmitter will present a voltage loop at two (or four) times that frequency.

When you operate with a random-length wire antenna, as in [Figs 1](#) and [2](#), you should try different types of grounds on the various bands, to see what gives you the best results. In many cases it will be satisfactory to return to the transmitter chassis for the ground, or directly to a convenient metallic water pipe. If neither of these works well (or the metallic water pipe is not available), a length of #12 or #14 wire (approximately  $\lambda/4$  long) can often be used to good advantage. Connect the wire at the point in the circuit that is shown grounded, and run it out and down the side of the house, or support it a few feet above the ground if the station is on the first floor or in the basement. It should not be



**Fig 1**—At A, a random-length wire driven directly from the pi-network output of a transmitter. At B, an L network for use in cases where sufficient loading cannot be obtained with the arrangement at A. C1 should have about the same plate spacing as the final tank capacitor in a vacuum-tube type of transmitter; a maximum capacitance of 100 pF is sufficient if L1 is 20 to 25  $\mu$ H. A suitable coil would consist of 30 turns of #12 wire, 2½ inches diameter, 6 turns per inch. Bare wire should be used so the tap can be placed as required for loading the transmitter.

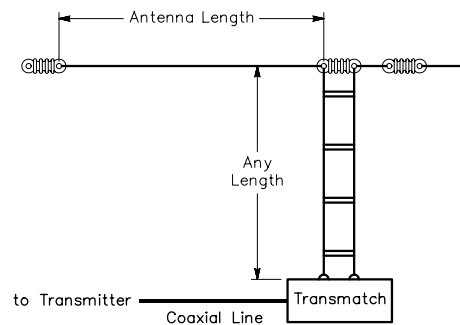


**Fig 2**—If the antenna length is 137 feet, a parallel-tuned coupling circuit can be used on each amateur band from 3.5 through 30 MHz, with the possible exception of the 10-, 18- and 24-MHz bands. C1 should duplicate the final tank tuning capacitor and L1 should have the same dimensions as the final tank inductor on the band being used. If the wire is 67 feet long, series tuning can be used on 3.5 MHz as shown at the left; parallel tuning will be required on 7 MHz and higher frequency bands. C2 and L2 will in general duplicate the final tank tuning capacitor and inductor, the same as with parallel tuning. The L network shown in Fig 1B is also suitable for these antenna lengths.

connected to actual ground at any point.

### END-FED ANTENNAS

When a straight-wire antenna is fed at one end with a two-wire transmission line, the length of the antenna portion becomes critical if radiation from the line is to be held to a minimum. Such an antenna system for multiband operation



**Fig 3**—An end-fed Zepp antenna for multiband use.

is the *end-fed Zepp* or *Zepp-fed* antenna shown in **Fig 3**. The antenna length is made  $\lambda/2$  long at the lowest operating frequency. (This name came about because the first documented use of this sort of antennas was on the Zeppelin balloons.) The feeder length can be anything that is convenient, but feeder lengths that are multiples of  $\lambda/4$  generally give trouble with parallel currents and radiation from the feeder portion of the system. The feeder can be an open-wire line of #14 solid copper wire spaced 4 or 6 inches with ceramic or plastic spacers. Open-wire TV line (not the type with a solid web of dielectric) is a convenient type to use. This type of line is available in approximately 300- and 450- $\Omega$  characteristic impedances.

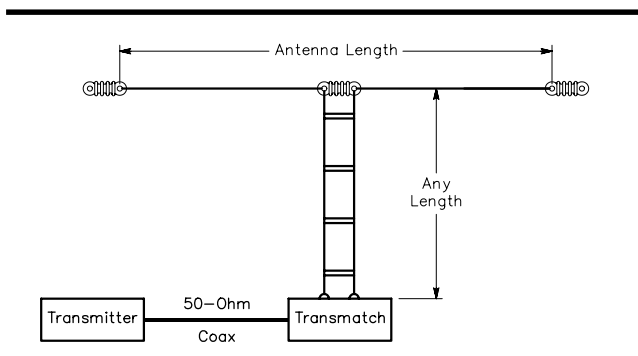
If one has room for only a 67-foot flat top and yet wants to operate in the 3.5-MHz band, the two feeder wires can be tied together at the transmitter end and the entire system treated as a random-length wire fed directly, as in **Fig 1**.

The simplest precaution against parallel currents that could cause feed-line radiation is to use a feeder length that is not a multiple of  $\lambda/4$ . An antenna tuner can be used to provide multiband coverage with an end-fed antenna with any length of open-wire feed line, as shown in **Fig 3**.

### CENTER-FED ANTENNAS

The simplest and most flexible (and also least expensive) all-band antennas are those using open-wire parallel-conductor feeders to the center of the antenna, as in **Fig 4**. Because each half of the flat top is the same length, the feeder currents will be balanced at all frequencies unless, of course, unbalance is introduced by one half of the antenna being closer to ground (or a grounded object) than the other. For best results and to maintain feed-current balance, the feeder should run away at right angles to the antenna, preferably for at least  $\lambda/4$ .

Center feed is not only more desirable than end feed because of inherently better balance, but generally also results in a lower standing wave ratio on the transmission line, provided a parallel-conductor line having a characteristic impedance of 450 to 600  $\Omega$  is used. TV-type open-wire line is satisfactory for all but possibly high power installations (over 500 W), where heavier wire and wider spacing is desirable to handle the larger currents and voltages.



**Fig 4—A center-fed antenna system for multiband use.**

The length of the antenna is not critical, nor is the length of the line. As mentioned earlier, the length of the antenna can be considerably less than  $\lambda/2$  and still be very effective. If the overall length is at least  $\lambda/4$  at the lowest frequency, a quite usable system will result. The only difficulty that may exist with this type of system is the matter of coupling the antenna-system load to the transmitter. Most modern transmitters are designed to work into a  $52 \Omega$  coaxial load. With this type of antenna system a coupling network (an antenna tuner) is required.

### Feed-Line Radiation

The preceding sections have pointed out means of reducing or eliminating feed-line radiation. However, it should be emphasized that any radiation from a transmission line is not “lost” energy and is not necessarily harmful. Whether or not feed-line radiation is important depends entirely on the antenna system being used. For example, feed-line radiation is not desirable when a directive array is being used. Such feed-line radiation can distort the desired pattern of such an array, producing responses in unwanted directions. In other words, one wants radiation only from the directive array, rather than from the directive array and the feed line. See [Chapter 26](#) for a detailed discussion of this topic.

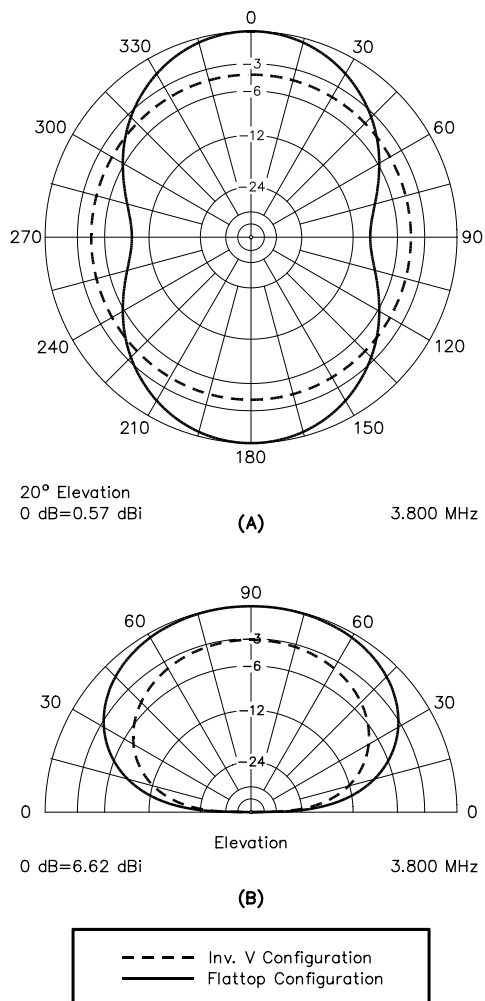
On the other hand, in the case of a multiband dipole where general coverage is desired, if the feed line happens to radiate, such energy could actually have a desirable effect. Antenna purists may dispute such a premise, but from a practical standpoint where one is not concerned with a directive pattern, much time and labor can be saved by ignoring possible transmission-line radiation.

### THE 135-FOOT, 80 TO 10-METER DIPOLE

As mentioned previously, one of the most versatile antennas around is a simple dipole, center-fed with open-wire transmission line and used with an antenna tuner in the shack. A 135-foot long dipole hung horizontally between two trees or towers at a height of 50 feet or higher works very well on 80 through 10 meters. Such an antenna system has significant gain at the higher frequencies.

### Flattop or Inverted-V Configuration?

There is no denying that the inverted-V mounting configuration (sometimes called a *drooping dipole*) is very convenient, since it requires only a single support. The flattop configuration, however, where the dipole is mounted horizontally, gives more gain at the higher frequencies. **Fig 5** shows the 80-meter azimuth and elevation patterns for two 135-foot long dipoles. The first is mounted as a flattop at a height of 50 feet over flat ground with a conductivity of 5 mS/m and a dielectric constant of 13, typical for “good soil.” The second dipole uses the same length of wire, with the center apex at 50 feet and the ends drooped down to be suspended 10 feet off the ground. This height is sufficient

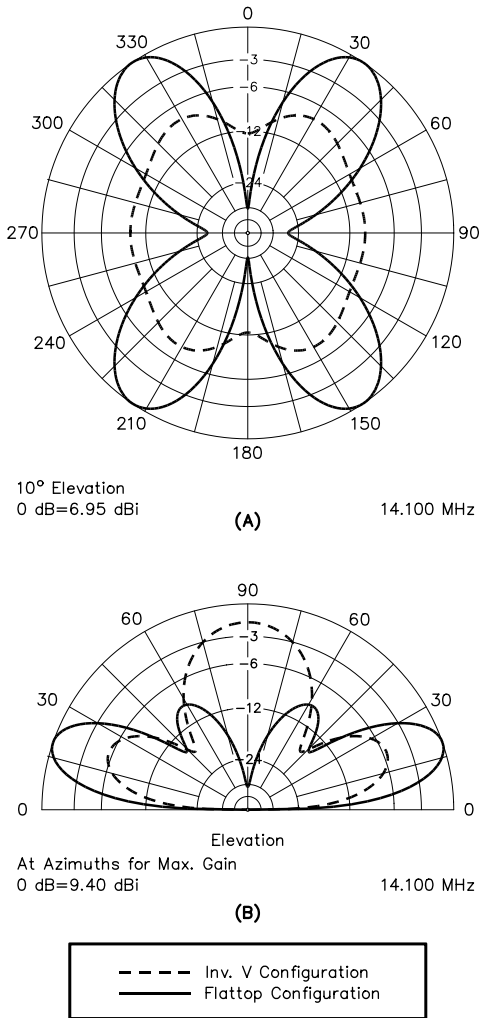


**Fig 5—Patterns on 80 meters for 135-foot, center-fed dipole erected as a horizontal flattop dipole at 50 feet, compared with the same dipole installed as an inverted V with the apex at 50 feet and the ends at 10 feet. The azimuth pattern is shown at A, where the dipole wire lies in the  $90^\circ$  to  $270^\circ$  plane. At B, the elevation pattern, the dipole wire comes out of the paper at a right angle. On 80 meters, the patterns are not markedly different from either flattop or inverted-V configuration.**

so that there is no danger to passersby from RF burns.

At 3.8 MHz, the flattop dipole has about 4 dB more peak gain than its drooping cousin. On the other hand, the inverted-V configuration gives a pattern that is more omnidirectional than the flattop dipole, which has nulls off the ends of the wire. Omnidirectional coverage may be more important to net operators, for example, than pure gain.

**Fig 6** shows the azimuth and elevation patterns for the same two antenna configurations, but this time at 14.2 MHz. The flattop dipole has developed four distinct lobes at a

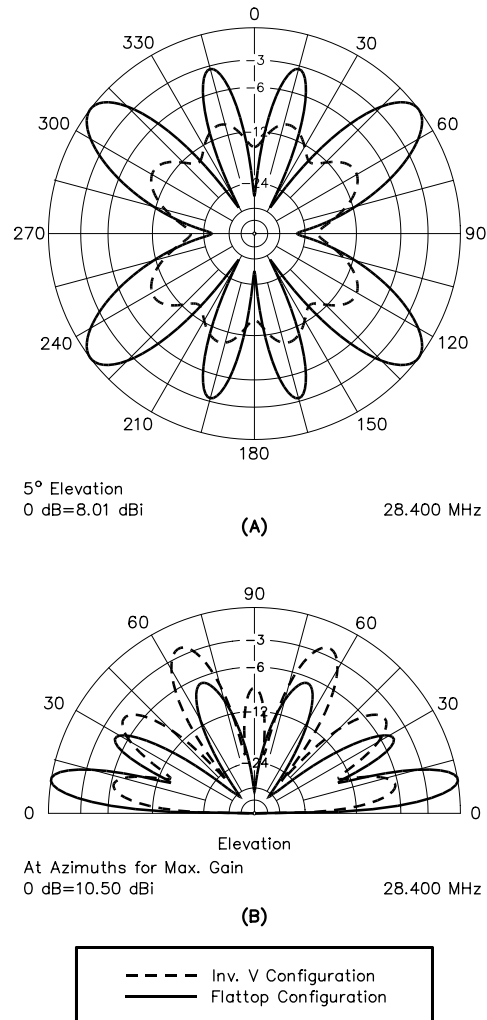


**Fig 6**—Patterns on 20 meters for two 135-foot dipoles. One is mounted horizontally as a flattop and the other as an inverted V with 120° included angle between the legs. The azimuth pattern is shown in A and the elevation pattern is shown in B. The inverted V has about 6 dB less gain at the peak azimuths, but has a more uniform, almost omnidirectional, azimuthal pattern. In the elevation plane, the inverted V has a fat lobe overhead, making it a somewhat better antenna for local communication, but not quite so good for DX contacts at low elevation angles.

10° elevation angle, an angle typical for 20-meter skywave communication. The peak elevation angle gain of 9.4 dBi occurs at about 17° for a height of 50 feet above flat ground for the flattop dipole. The inverted-V configuration is again nominally more omnidirectional, but the peak gain is down some 6 dB from the flattop.

The situation gets even worse in terms of peak gain at 28.4 MHz for the inverted-V configuration. Here the peak gain is down about 8 dB from that produced by the flattop dipole, which exhibits eight lobes at this frequency with a maximum gain of 10.5 dBi at about 7° elevation. See the comparisons in **Fig 7**.

Whatever configuration you choose to mount the 135-foot dipole, you will want to feed it with some sort of low-loss open-wire transmission line. So-called *window* 450-Ω ladder line is popular for this application. Be sure to



**Fig 7**—Patterns on 10 meters for same antenna configurations as in Figs 5 and 6. Once again, the inverted-V configuration yields a more omnidirectional pattern, but at the expense of almost 8 dB less gain than the flattop configuration at its strongest lobes.



twist the line about three or four turns per foot to keep it from twisting excessively in the wind. Make sure also that you provide some mechanical support for the line at the junction with the dipole wires. This will prevent flexing of the transmission-line wire, since excessive flexing will result in breakage.

### THE G5RV MULTIBAND ANTENNA

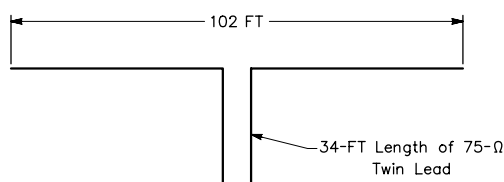
A multiband antenna that does not require a lot of space, is simple to construct, and is low in cost is the G5RV. Designed in England by [Louis Varney \(G5RV\)](#) some years ago, it has become quite popular in the US. The G5RV design is shown in **Fig 8**. The antenna may be used from 3.5 through 30 MHz. Although some amateurs claim it may be fed directly with 50-Ω coax on several amateur bands with a low SWR, Varney himself recommends the use of an antenna tuner on bands other than 14 MHz (see Bibliography). In fact, an analysis of the G5RV feed-point impedance shows there is *no* length of balanced line of *any* characteristic impedance that will transform the terminal impedance to the 50 to 75-Ω range on all bands. (Low SWR indication with coax feed and no matching network on bands other than 14 MHz may indicate excessive losses in the coaxial line.)

The portion of the antenna shown as horizontal in **Fig 8** may also be installed in an inverted-V dipole arrangement, subject to the same loss of peak gain mentioned above for the 135-foot dipole. Or instead, up to 1/6 of the total length of the antenna at each end may be dropped vertically, semi-vertically, or bent at a convenient angle to the main axis of the antenna, to cut down on the requirements for real estate.

### THE WINDOM ANTENNA

An antenna that enjoyed popularity in the 1930s and into the 1940s was what we now call the *Windom*. It was known at the time as a “single-feeder Hertz” antenna, after being described in Sep 1929 *QST* by [Loren G. Windom, W8GZ](#) (see Bibliography).

The Windom antenna, shown in **Fig 9**, is fed with a single wire, attached approximately 14% off center. The system is worked against an earth ground. Because the feed line is brought to the operating position, “RF in the shack” and a potential radiation hazard may be experienced with this antenna.

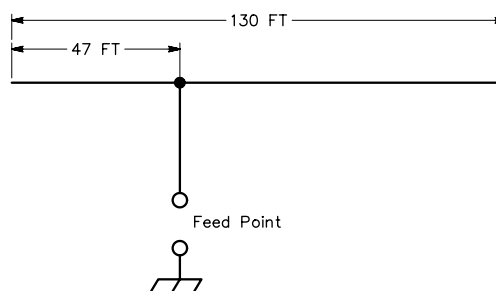


**Fig 8**—The G5RV multiband antenna covers 3.5 through 30 MHz. Although many amateurs claim it may be fed directly with 50-Ω coax on several amateur bands, Louis Varney, its originator, recommends the use of a matching network on bands other than 14 MHz.

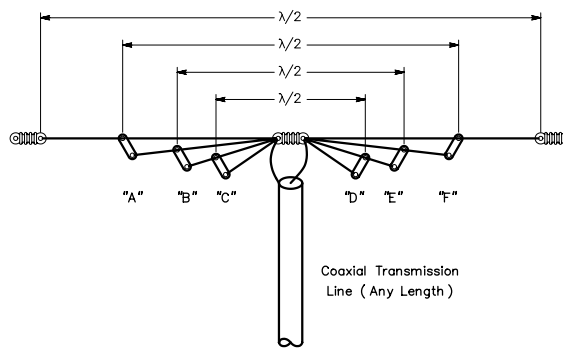
### MULTIPLE-DIPOLE ANTENNAS

The antenna system shown in **Fig 10** consists of a group of center-fed dipoles, all connected in parallel at the point where the transmission line joins them. The dipole elements are *stagger-tuned*. That is, they are individually cut to be  $\lambda/2$  at different frequencies. **Chapter 9** discusses the stagger tuning of dipole antennas to attain a low SWR across a broad range of frequencies. An extension of the stagger tuning idea is to construct multiwire dipoles cut for different bands.

In theory, the 4-wire antenna of **Fig 10** can be used with a coaxial feeder on five bands. The four wires are prepared as parallel-fed dipoles for 3.5, 7, 14, and 28 MHz. The 7-MHz dipole can be operated on its 3rd harmonic for 21-MHz operation to cover the 5th band. However, in practice it has been found difficult to get a good match to coaxial line on all bands. The  $\lambda/2$  resonant length of any one dipole in the presence of the others is not the same as



**Fig 9**—The Windom antenna, cut for a fundamental frequency of 3.75 MHz. The single-wire feeder, connected 14% off center, is brought into the station and the system is fed against ground. The antenna is also effective on its harmonics.



**Fig 10**—Multiband antenna using paralleled dipoles all connected to a common low-impedance transmission line. The half-wave dimensions may be either for the centers of the various bands or selected to fit favorite frequencies in each band. The length of a half wave in feet is 468/frequency in MHz, but because of interaction among the various elements, some pruning for resonance may be needed on each band.

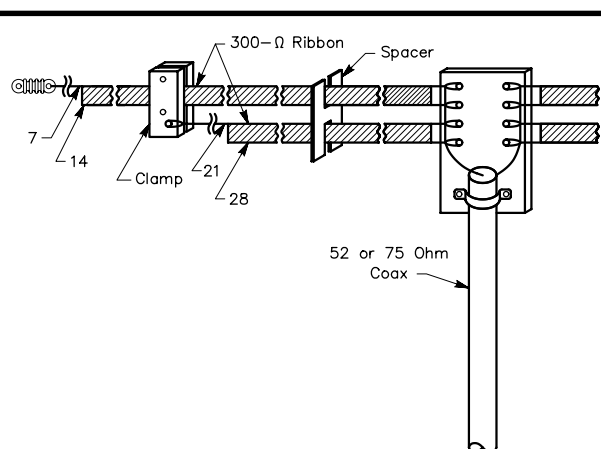
for a dipole by itself due to interaction, and attempts to optimize all four lengths can become a frustrating procedure. The problem is compounded because the optimum tuning changes in a different antenna environment, so what works for one amateur may not work for another. Even so, many amateurs with limited antenna space are willing to accept the mismatch on some bands just so they can operate on those frequencies using a single coax feed line.

Since this antenna system is balanced, it is desirable to use a balanced transmission line to feed it. The most desirable type of line is 75-Ω transmitting twin-lead. However, either 52-Ω or 75-Ω coaxial line can be used; coax line introduces some unbalance, but this is tolerable on the lower frequencies. An alternative is to use a balun at the feed point, fed with coaxial cable.

The separation between the dipoles for the various frequencies does not seem to be especially critical. One set of wires can be suspended from the next larger set, using insulating spreaders (of the type used for feeder spreaders) to give a separation of a few inches. Users of this antenna often run some of the dipoles at right angles to each other to help reduce interaction. Some operators use inverted-V-mounted dipoles as guy wires for the mast that supports the antenna system.

An interesting method of construction used successfully by [Louis Richard, ON4UF](#), is shown in **Fig 11**. The antenna has four dipoles (for 7, 14, 21 and 28 MHz) constructed from 300-Ω ribbon transmission line. A single length of ribbon makes two dipoles. Thus, two lengths, as shown in the sketch, serve to make dipoles for four bands. Ribbon with copper-clad steel conductors (Amphenol type 14-022) should be used because all of the weight, including that of the feed line, must be supported by the uppermost wire.

Two pieces of ribbon are first cut to a length suitable for the two halves of the longest dipole. Then one of the next



**Fig 11**—Sketch showing how the twin-lead multiple-dipole antenna system is assembled. The excess wire and insulation are stripped away.

band higher in frequency. The excess wire and insulation is stripped away. A second pair of lengths is prepared in the same manner, except that the lengths are appropriate for the next two higher frequency bands.

A piece of thick polystyrene sheet drilled with holes for anchoring each wire serves as the central insulator. The shorter pair of dipoles is suspended the width of the ribbon below the longer pair by clamps also made of poly sheet. Intermediate spacers are made by sawing slots in pieces of poly sheet so they will fit the ribbon snugly.

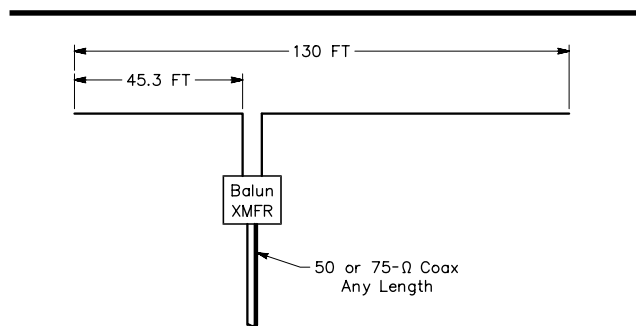
The multiple-dipole principle can also be applied to vertical antennas. Parallel or fanned  $\lambda/4$  elements of wire or tubing can be worked against ground or tuned radials from a common feed point.

### OFF-CENTER-FED DIPOLES

**Fig 12** shows the off-center-fed or *OCF* dipole. Because it is similar in appearance to the Windom of **Fig 9**, this antenna is often mistakenly called a “Windom,” or sometimes a “coax-fed Windom.” The two antennas are not the same, as the Windom is worked against its image in the ground, while one leg is worked against the other in the OCF dipole.

It is not necessary to feed a dipole antenna at its center, although doing so will allow it to be operated with a relatively low feed-point impedance on its fundamental and *odd* harmonics. (For example, a 7-MHz center-fed half-wave dipole can also be used for 21-MHz operation.) By contrast, the OCF dipole of **Fig 12**, fed 1/3 of its length from one end, may be used on its fundamental and *even* harmonics. Its free-space antenna-terminal impedance at 3.5, 7 and 14 MHz is on the order of 150 to 200 Ω. A 1:4 step-up transformer at the feed point should offer a reasonably good match to 50- or 75-Ω line, although some commercially made OCF dipoles use a 1:6 transformer.

At the 6th harmonic, 21 MHz, the antenna is three wavelengths long and fed at a voltage loop (maximum), instead of a current loop. The feed-point impedance at this frequency is high, a few thousand ohms, so the antenna is unsuitable for use on this band.



**Fig 12**—The off-center-fed (OCF) dipole for 3.5, 7 and 14 MHz. A 1:4 or 1:6 step-up current balun is used at the feed point.

## Balun Requirements

Because the OCF dipole is not fed at the center of the radiator, the RF impedance paths of the two wires at the feed point are unequal. If the antenna is fed directly with coax (or a balanced line), or if a voltage step-up transformer is used, then voltages of equal magnitude (but opposite polarity) are applied to the wires at the feed point. Because of unequal impedances, the resulting antenna currents flowing in the two wires will not be equal. (This also means

that antenna current can flow on the feeder—on the *outside* of the coaxial line.

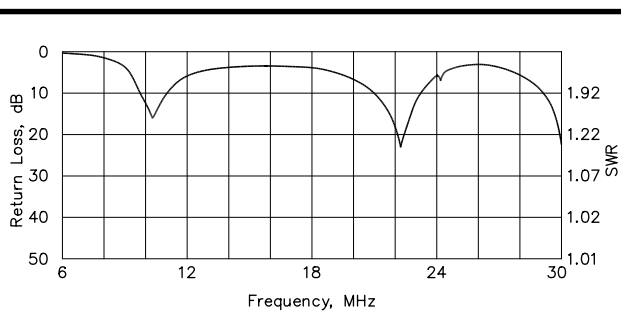
How much current flows there depends on the impedance of the RF current path down the outside of the feed line.) This is not a desirable situation. Rather, equal *currents* are required at the feed point, with the same current flowing in and out of the short leg as in and out of the long leg of the radiator. A *current* or *choke* type of balun provides just such operation. (Current baluns are discussed in detail in [Chapter 26](#).)

# Trap Antennas

By using tuned circuits of appropriate design strategically placed in a dipole, the antenna can be made to show what is essentially fundamental resonance at a number of different frequencies. The general principle is illustrated by **Fig 13**.

Even though a trap-antenna arrangement is a simple one, an explanation of how a trap antenna works can be elusive. For some designs, traps are resonated in our amateur bands, and for others (especially commercially made antennas) the traps are resonant far outside any amateur band.

A trap in an antenna system can perform either of two functions, depending on whether or not it is resonant at the operating frequency. A familiar case is where the trap is parallel-resonant in an amateur band. For the moment, let us assume that dimension A in Fig 13 is 33 feet and that each L/C combination is resonant in the 7-MHz band. Because of its parallel resonance, the trap presents a high impedance at that point in the antenna system. The electrical effect at 7 MHz is that the trap behaves as an insulator. It serves to divorce the outside ends, the B sections, from the antenna. The result is easy to visualize—we have an antenna system that is resonant in the 7-MHz band. Each 33-foot section (labeled A in the drawing) represents  $\lambda/4$ , and the trap behaves as an insulator. We therefore have a full-size 7-MHz antenna.



**Fig 13—A trap dipole antenna. This antenna may be fed with 52- $\Omega$  coaxial line. Depending on the L/C ratio of the trap elements and the lengths chosen for dimensions A and B, the traps may be resonant either in an amateur band or at a frequency far removed from an amateur band for proper two-band antenna operation.**

The second function of a trap, obtained when the frequency of operation is *not* the resonant frequency of the trap, is one of electrical loading. If the operating frequency is below that of trap resonance, the trap behaves as an inductor; if above, as a capacitor. Inductive loading will electrically lengthen the antenna, and capacitive loading will electrically shorten the antenna.

Let's carry our assumption a bit further and try using the antenna we just considered at 3.5 MHz. With the traps resonant in the 7-MHz band, they will behave as inductors when operation takes place at 3.5 MHz, electrically lengthening the antenna. This means that the total length of sections A and B (plus the length of the inductor) may be something less than a physical  $\lambda/4$  for resonance at 3.5 MHz. Thus, we have a two-band antenna that is shorter than full size on the lower frequency band. But with the electrical loading provided by the traps, the overall electrical length is  $\lambda/2$ . The total antenna length needed for resonance in the 3.5-MHz band will depend on the L/C ratio of the trap elements.

The key to trap operation off resonance is its L/C ratio, the ratio of the value of L to the value of C. At resonance, however, within practical limitations the L/C ratio is immaterial as far as electrical operation goes. For example, in the antenna we've been discussing, it would make no difference for 7-MHz operation whether the inductor were 1  $\mu\text{H}$  and the capacitor were 500 pF (the reactances would be just below 45  $\Omega$  at 7.1 MHz), or whether the inductor were 5  $\mu\text{H}$  and the capacitor 100 pF (reactances of approximately 224  $\Omega$  at 7.1 MHz). But the choice of these values will make a significant difference in the antenna size for resonance at 3.5 MHz. In the first case, where the L/C ratio is 2000, the necessary length of section B of the antenna for resonance at 3.75 MHz would be approximately 28.25 feet. In the second case, where the L/C ratio is 50,000, this length need be only 24.0 feet, a difference of more than 15%.

The above example concerns a two-band antenna with trap resonance at one of the two frequencies of operation. On each of the two bands, each half of the dipole operates as an electrical  $\lambda/4$ . However, the same band coverage can be obtained with a trap resonant at, say, 5 MHz, a frequency quite removed from either amateur band. With proper selection of the L/C ratio and the dimensions for A and B, the trap will act to shorten the antenna electrically at 7 MHz

and lengthen it electrically at 3.5 MHz. Thus, an antenna that is intermediate in physical length between being full size on 3.5 MHz and full size on 7 MHz can cover both bands, even though the trap is not resonant at either frequency. Again, the antenna operates with electrical  $\lambda/4$  sections.

Additional traps may be added in an antenna section to cover three or more bands. Or a judicious choice of dimensions and the L/C ratio may permit operation on three or more bands with just a pair of identical traps in the dipole.

An important point to remember about traps is this. If the operating frequency is below that of trap resonance, the trap behaves as an inductor; if above, as a capacitor. The above discussion is based on dipoles that operate electrically as  $\lambda/2$  antennas. This is not a requirement, however. Elements may be operated as electrical  $3/2 \lambda$ , or even  $5/2 \lambda$ , and still present a reasonable impedance to a coaxial feeder. In trap antennas covering several HF bands, using electrical lengths that are odd multiples of  $\lambda/2$  is often done at the higher frequencies.

To further aid in understanding trap operation, let's now choose trap L and C components that each have a reactance of  $20 \Omega$  at 7 MHz. Inductive reactance is directly proportional to frequency, and capacitive reactance is inversely proportional. When we shift operation to the 3.5-MHz band, the inductive reactance becomes  $10 \Omega$ , and the capacitive reactance becomes  $40 \Omega$ . At first thought, it may seem that the trap would become capacitive at 3.5 MHz with a higher capacitive reactance, and that the extra capacitive reactance would make the antenna electrically shorter yet. Fortunately, this is not the case. The inductor and the capacitor are connected in parallel with each other

$$Z = \frac{-jX_L X_C}{X_L - X_C} \quad (\text{Eq 1})$$

where  $j$  indicates a reactive impedance component, rather than resistive. A positive result indicates inductive reactance, and a negative result indicates capacitive. In this 3.5-MHz case, with  $40 \Omega$  of capacitive reactance and  $10 \Omega$  of inductive, the equivalent series reactance is  $13.3 \Omega$  inductive. This inductive loading lengthens the antenna to an electrical  $\lambda/2$  overall at 3.5 MHz, assuming the B end sections in Fig 13 are of the proper length.

With the above reactance values providing resonance at 7-MHz,  $X_L$  equals  $X_C$ , and the theoretical series equivalent is infinity. This provides the insulator effect, divorcing the ends.

At 14 MHz, where  $X_L = 40 \Omega$  and  $X_C = 10 \Omega$ , the resultant series equivalent trap reactance is  $13.3 \Omega$  capacitive. If the total physical antenna length is slightly longer than  $3/2 \lambda$  at 14 MHz, this trap reactance at 14 MHz can be used to shorten the antenna to an electrical  $3/2 \lambda$ . In this way, 3-band operation is obtained for 3.5, 7 and 14 MHz with just one pair of identical traps. The design of such a system is not straightforward, however, for any chosen L/C ratio for a given total length affects the resonant frequency of the antenna on both the 3.5 and 14-MHz bands.

## Trap Losses

Since the tuned circuits have some inherent losses, the efficiency of a trap system depends on the unloaded Q values of the tuned circuits. Low-loss (high-Q) coils should be used, and the capacitor losses likewise should be kept as low as possible. With tuned circuits that are good in this respect—comparable with the low-loss components used in transmitter tank circuits, for example—the reduction in efficiency compared with the efficiency of a simple dipole is small, but tuned circuits of low unloaded Q can lose an appreciable portion of the power supplied to the antenna.

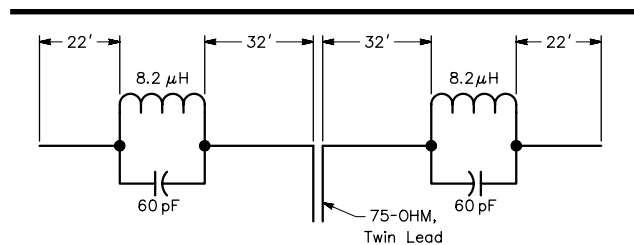
The commentary above applies to traps assembled from conventional components. The important function of a trap that is resonant in an amateur band is to provide a high isolating impedance, and this impedance is directly proportional to Q. Unfortunately, high Q restricts the antenna bandwidth, because the traps provide maximum isolation only at trap resonance.

## FIVE-BAND W3DZZ TRAP ANTENNA

C. L. Buchanan, W3DZZ, created one of the first trap antennas for the five pre-WARC amateur bands from 3.5 to 30 MHz. Dimensions are given in Fig 14. Only one set of traps is used, resonant at 7 MHz to isolate the inner (7-MHz) dipole from the outer sections. This causes the overall system to be resonant in the 3.5-MHz band. On 14, 21 and 28 MHz the antenna works on the capacitive-reactance principle just outlined. With a  $75\text{-}\Omega$  twin-lead feeder, the SWR with this antenna is under 2:1 throughout the three highest frequency bands, and the SWR is comparable with that obtained with similarly fed simple dipoles on 3.5 and 7 MHz.

## Trap Construction

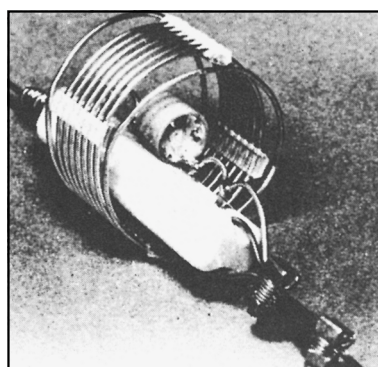
Traps frequently are built with coaxial aluminum tubes (usually with polystyrene tubing between them for insulation) for the capacitor, with the coil either self-supporting or wound on a form of larger diameter than the tubular capacitor. The coil is then mounted coaxially with



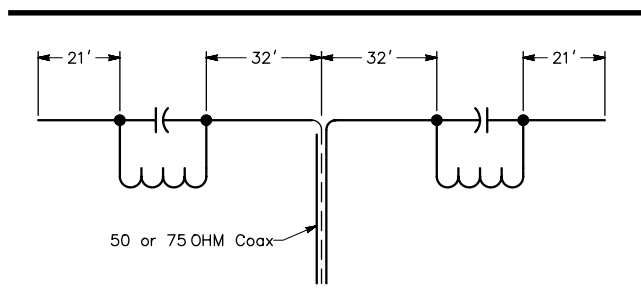
**Fig 14—Five-band (3.5, 7, 14, 21 and 28 MHz) trap dipole for operation with  $75\text{-}\Omega$  feeder at low SWR (C. L. Buchanan, W3DZZ). The balanced (parallel-conductor) line indicated is desirable, but  $75\text{-}\Omega$  coax can be substituted with some sacrifice of symmetry in the system. Dimensions given are for resonance (lowest SWR) at 3.75, 7.2, 14.15 and 29.5 MHz. Resonance is very broad on the 21-MHz band, with SWR less than 2:1 throughout the band.**

the capacitor to form a unit assembly that can be supported at each end by the antenna wires. In another type of trap devised by [William J. Lattin, W4JRW](#) (see Bibliography at the end of this chapter), the coil is supported inside an aluminum tube and the trap capacitor is obtained in the form of capacitance between the coil and the outer tube. This type of trap is inherently weatherproof.

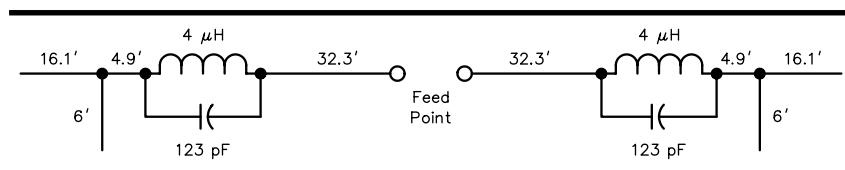
A simpler type of trap, easily assembled from readily available components, is shown in **Fig 15**. A small transmitting-type ceramic “doorknob” capacitor is used, together with a length of commercially available coil material, these being supported by an ordinary antenna strain insulator. The circuit constants and antenna dimensions differ slightly from those of [Fig 14](#), in order to bring the antenna resonance points closer to the centers of the various phone bands. Construction data are given in **Fig 16**. If a 10-turn



**Fig 15**—Easily constructed trap for wire antennas ([A. Greenburg, W2LH](#)). The ceramic insulator is 4¼ inches long ([Birnbach 688](#)). The clamps are small service connectors available from electrical supply and hardware stores ([Burndy KS90 servits](#)).



**Fig 16**—Layout of multiband antenna using traps constructed as shown in [Fig 15](#). The capacitors are 100 pF each, transmitting type, 5000-volt dc rating ([Centralab 850SL-100N](#)). Coils are 9 turns of no. 12 wire, 2½ inches diameter, 6 turns per inch ([B&W 3029](#)) with end turns spread as necessary to resonate the traps to 7.2 MHz. These traps, with the wire dimensions shown, resonate the antenna at approximately the following frequencies on each band: 3.9, 7.25, 14.1, 21.5 and 29.9 MHz (based on measurements by [W9YJH](#)).



**Fig 17**—A W8NX multiband dipole for 80, 40, 20, 15 and 10 meters. The values shown (123 pF and 4 µH) for the coaxial-cable traps are for parallel resonance at 7.15 MHz. The low-impedance output of each trap is used for this antenna.

length of inductor is used, a half turn from each end may be used to slip through the anchor holes in the insulator to act as leads.

The components used in these traps are sufficiently weatherproof in themselves so that no additional weatherproofing has been found necessary. However, if it is desired to protect them from the accumulation of snow or ice, a plastic cover can be made by cutting two discs of polystyrene slightly larger in diameter than the coil, drilling at the center to pass the antenna wires, and cementing a plastic cylinder on the edges of the discs. The cylinder can be made by wrapping two turns or so of 0.02-inch poly or Lucite sheet around the discs, if no suitable ready-made tubing is available. Plastic drinking glasses and 2-liter soft-drink plastic bottles are easily adaptable for use as impromptu trap covers.

## TWO W8NX MULTIBAND, COAX-TRAP DIPOLES

Over the last 60 or 70 years, amateurs have used many kinds of multiband antennas to cover the traditional HF bands. The availability of the 30, 17 and 12-meter bands has expanded our need for multiband antenna coverage.

Two different antennas are described here. The first covers the traditional 80, 40, 20, 15 and 10 meter bands, and the second covers 80, 40, 17 and 12 meters. Each uses the same type of W8NX trap—connected for different modes of operation—and a pair of short capacitive stubs to enhance coverage. The W8NX coaxial-cable traps have two different modes: a high- and a low-impedance mode. The inner-conductor windings and shield windings of the traps are connected in series for both modes. However, either the low- or high-impedance point can be used as the trap’s output terminal. For low-impedance trap operation, only the center conductor turns of the trap windings are used. For high-impedance operation, all turns are used, in the conventional manner for a trap. The short stubs on each antenna are strategically sized and located to permit more flexibility in adjusting the resonant frequencies of the antenna.

### 80, 40, 20, 15 and 10-Meter Dipole

**Fig 17** shows the configuration of the 80, 40, 20, 15 and 10-meter antenna. The radiating elements are made of #14 stranded copper wire. The element lengths are the wire span lengths in feet. These lengths do not include the lengths of the pigtailed at the balun, traps and insulators. The 32.3-foot-long inner 40-meter segments are measured from the eyelet of the input balun to the tension-relief hole in the trap coil form. The 4.9-foot segment length is measured from the tension-relief hole in the trap to the 6-foot stub. The 16.1-foot outer-segment span is measured from the stub to the eyelet of the end insulator.

The coaxial-cable traps are wound on PVC pipe coil forms and use the low-impedance output connection. The stubs are 6-foot lengths of 1/8-inch stiffened aluminum or copper rod hanging perpendicular to the radiating elements. The first inch of their length is bent 90° to permit attachment to the radiating elements by large-diameter copper crimp connectors. Ordinary #14 wire may be used for the stubs, but it has a tendency to curl up and may tangle unless weighed down at the end. You should feed the antenna with 75-Ω coax cable using a good 1:1 balun.

This antenna may be thought of as a modified W3DZZ antenna due to the addition of the capacitive stubs. The length and location of the stub give the antenna designer two extra degrees of freedom to place the resonant frequencies within the amateur bands. This additional flexibility is particularly helpful to bring the 15 and 10-meter resonant frequencies to more desirable locations in these bands. The actual 10-meter resonant frequency of the original W3DZZ antenna is somewhat above 30 MHz, pretty remote from the more desirable low frequency end of 10 meters.

### 80, 40, 17 and 12-Meter Dipole

Fig 18 shows the configuration of the 80, 40, 17 and 12-meter antenna. Notice that the capacitive stubs are attached immediately outboard after the traps and are 6.5 feet long, 1/2 foot longer than those used in the other antenna. The traps are the same as those of the other antenna, but are connected for the high-impedance parallel-resonant output mode. Since only four bands are covered by this antenna, it is easier to fine tune it to precisely the desired frequency on all bands. The 12.4-foot tips can be pruned to a particular 17-meter frequency with little effect on the 12-meter frequency. The stub lengths can be pruned to a particular 12-meter frequency with little effect on the 17-meter frequency. Both such pruning adjustments slightly alter the 80-meter resonant frequency. However, the bandwidths of the antennas are so broad on 17 and 12 meters that little need for such pruning exists. The 40-meter frequency is nearly independent of adjustments to the capacitive stubs and outer radiating tip elements. Like the first antennas, this dipole is fed with a 75-Ω balun and feed line.

Fig 19 shows the schematic diagram of the traps. It explains the difference between the low and high-impedance modes of the traps. Notice that the high-impedance terminal is the output configuration used in most conventional trap applications. The low-impedance connection is made across only the inner conductor turns, corresponding to one-half of

the total turns of the trap. This mode steps the trap's impedance down to approximately one-fourth of that of the high-impedance level. This is what allows a single trap design to be used for two different multiband antennas.

Fig 20 is a drawing of a cross-section of the coax trap shown through the long axis of the trap. Notice that the traps are conventional coaxial-cable traps, except for the added low-impedance output terminal. The traps are 8<sup>3</sup>/<sub>4</sub> close-spaced turns of RG-59 (Belden 8241) on a 2<sup>3</sup>/<sub>8</sub>-inch-OD PVC pipe (schedule 40 pipe with a 2-inch ID) coil form. The forms are 4<sup>1</sup>/<sub>8</sub> inches long. Trap resonant frequency is very sensitive to the outer diameter of the coil form, so check it carefully. Unfortunately, not all PVC pipe is made with the same wall thickness. The trap frequencies should be checked with a dip meter and general-coverage receiver and adjusted to within 50 kHz of the 7150 kHz resonant frequency before installation. One inch is left over at each end of the coil forms to allow for the coax feed-through holes and holes for tension-relief attachment of the antenna radiating elements to the traps. Be sure to seal the ends of the trap coax cable with RTV sealant to prevent moisture from entering the coaxial cable.

Also, be sure that you connect the 32.3-foot wire element at the start of the inner conductor winding of the trap. This avoids detuning the antenna by the stray capacitance of the coaxial-cable shield. The trap output terminal (which has the shield stray capacitance) should be at the outboard side of the trap. Reversing the input and output terminals of the trap will lower the 40-meter frequency by approximately 50 kHz, but there will be negligible effect on the other bands.

Fig 21 shows a coaxial-cable trap. Further details of the trap installation are shown in Fig 22. This drawing applies specifically to the 80, 40, 20, 15 and 10-meter antenna, which uses the low-impedance trap connections. Notice the lengths of the trap pigtails: 3 to 4 inches at each terminal of the trap. If you use a different arrangement, you must modify the span

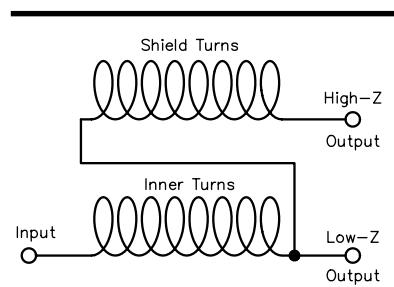


Fig 19—Schematic for the W8NX coaxial-cable trap. RG-59 is wound on a 2<sup>3</sup>/<sub>8</sub>-inch OD PVC pipe.

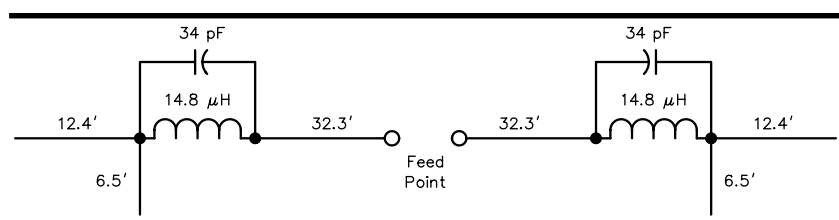


Fig 18—A W8NX multiband dipole for 80, 40, 17 and 12 meters. For this antenna, the high-impedance output is used on each trap. The resonant frequency of the traps is 7.15 MHz.

lengths accordingly, All connections can be made using crimp connectors rather than by soldering. Access to the trap's interior is attained more easily with a crimping tool than with a soldering iron.

### Performance

The performance of both antennas has been very satisfactory. W8NX uses the 80, 40, 17 and 12-meter version because it covers 17 and 12 meters. (He has a tribander for 20, 15 and 10 meters.) The radiation pattern on 17 meters is that of  $3/2$ -wave dipole. On 12 meters, the pattern is that of a  $5/2$ -wave dipole. At his location in Akron, Ohio, the antenna runs essentially east and west. It is installed as an inverted V, 40 feet high at the center, with a  $120^\circ$  included angle between the legs. Since the stubs are very short, they radiate little power and make only minor contributions to the radiation patterns. In theory, the pattern has four major lobes on 17 meters, with maxima to the northeast, southeast, southwest and northwest. These provide low-angle radiation into Europe, Africa, South Pacific, Japan and Alaska. A narrow pair of minor broadside lobes provides north and south coverage into Central America, South America and the polar regions.

There are four major lobes on 12 meters, giving nearly end-fire radiation and good low-angle east and west coverage. There are also three pairs of very narrow, nearly broadside, minor lobes on 12 meters, down about 6 dB from the major end-fire lobes. On 80 and 40 meters, the antenna has the usual figure-8 patterns of a half-wave-length dipole.

Both antennas function as electrical half-wave dipoles on 80 and 40 meters with a low SWR. They both function as odd-harmonic current-fed dipoles on their other operating frequencies, with higher, but still acceptable, SWR. The presence of the stubs can either raise or lower the input impedance of the antenna from those of the usual third and fifth harmonic dipoles. Again W8NX recommends that 75- $\Omega$ , rather than 50- $\Omega$ , feed line be used because of the

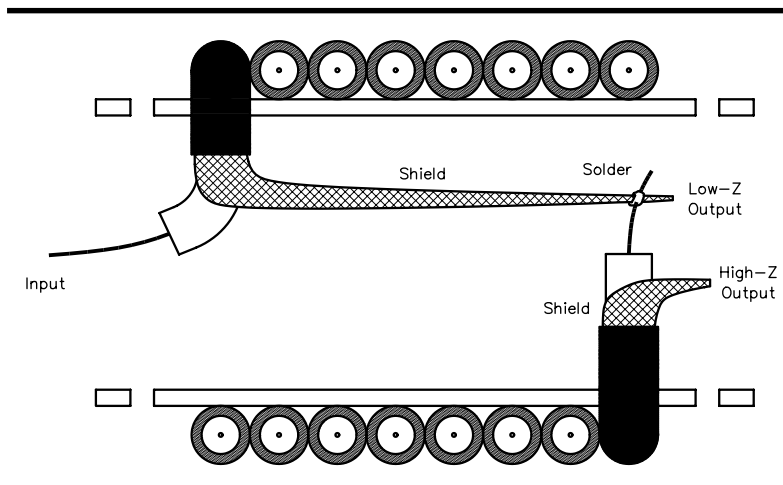


Fig 20—Construction details of the W8NX coaxial-cable trap.

generally higher input impedances at the harmonic operating frequencies of the antennas.

The SWR curves of both antennas were carefully measured using a 75 to 50- $\Omega$  transformer from Palomar Engineers inserted at the junction of the 75- $\Omega$  coax feed

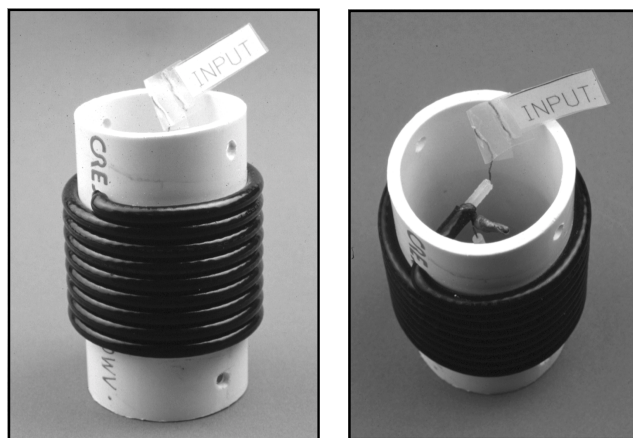


Fig 21—Other views of a W8NX coax-cable trap.

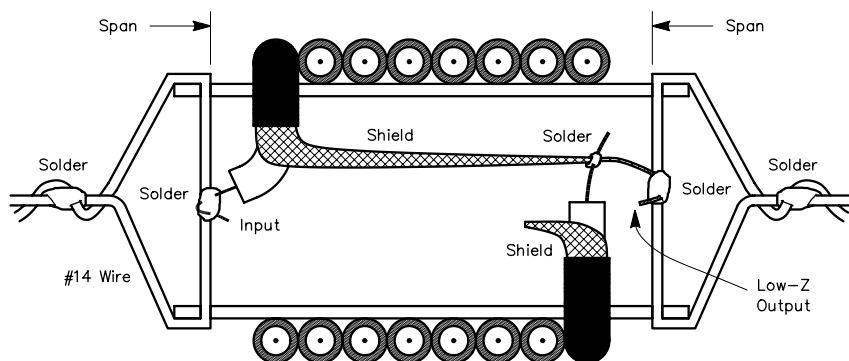


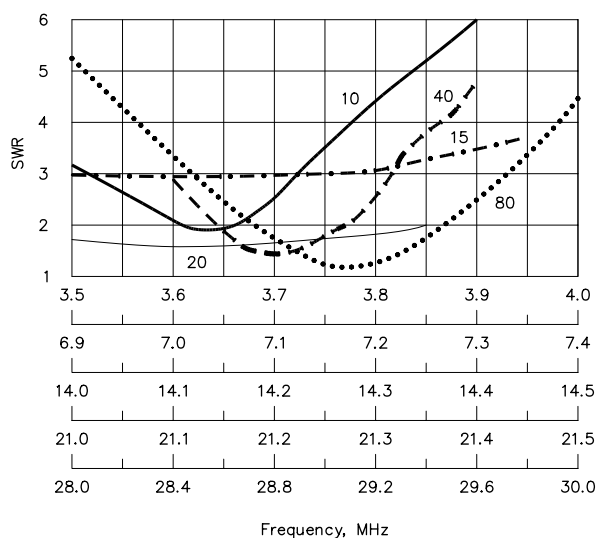
Fig 22—Additional construction details for the W8NX coaxial-cable trap.

line and a 50-Ω SWR bridge. The transformer is required for accurate SWR measurement if a 50-Ω SWR bridge is used with a 75-Ω line. Most 50-Ω rigs operate satisfactorily with a 75-Ω line, although this requires different tuning and load settings in the final output stage of the rig or antenna tuner. The author uses the 75 to 50-Ω transformer only when making SWR measurements and at low power levels. The transformer is rated for 100 W, and when he runs his 1-kW PEP linear amplifier the transformer is taken out of the line.

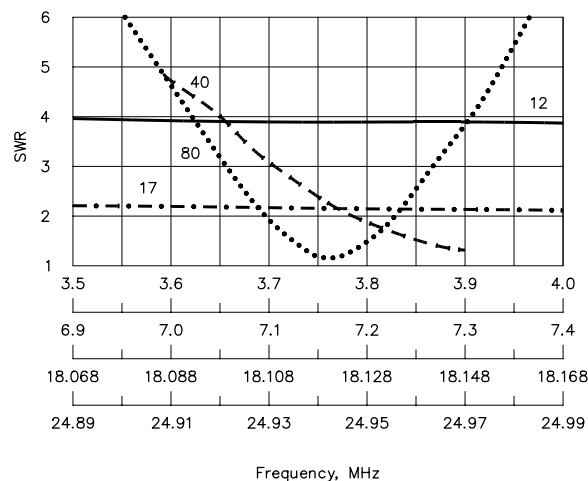
**Fig 23** gives the SWR curves of the 80, 40, 20, 15 and 10-meter antenna. Minimum SWR is nearly 1:1 on 80 meters, 1.5:1 on 40 meters, 1.6:1 on 20 meters, and 1.5:1 on 10 meters. The minimum SWR is slightly below 3:1 on 15 meters. On 15 meters, the stub capacitive reactance combines with the inductive reactance of the outer segment of the antenna to produce a resonant rise that raises the antenna input resistance to about 220 Ω, higher than that of the usual  $\frac{3}{2}$ -wavelength dipole. An antenna tuner may be required on this band to keep a solid-state final output stage happy under these load conditions.

**Fig 24** shows the SWR curves of the 80, 40, 17 and 12-meter antenna. Notice the excellent 80-meter performance with a nearly unity minimum SWR in the middle of the band. The performance approaches that of a full-size 80-meter wire dipole. The short stubs and the low-inductance traps shorten the antenna somewhat on 80 meters. Also observe the good 17-meter performance, with the SWR being only a little above 2:1 across the band.

But notice the 12-meter SWR curve of this antenna, which shows 4:1 SWR across the band. The antenna input resistance approaches 300 Ω on this band because the capacitive reactance of the stubs combines with the inductive



**Fig 23—Measured SWR curves for an 80, 40, 20, 15 and 10-meter antenna, installed as an inverted-V with 40-ft apex and 120° included angle between legs.**



**Fig 24—Measured SWR curves for an 80, 40, 17 and 12-meter antenna, installed as an inverted-V with 40-ft apex and 120° included angle between legs.**

reactance of the outer antenna segments to give resonant rises in impedance. These are reflected back to the input terminals. These stub-induced resonant impedance rises are similar to those on the other antenna on 15 meters, but are even more pronounced.

Too much concern must not be given to SWR on the feed line. Even if the SWR is as high as 9:1 *no destructively high voltages will exist on the transmission line*. Recall that transmission-line voltages increase as the square root of the SWR in the line. Thus, 1 kW of RF power in 75-Ω line corresponds to 274 V line voltage for a 1:1 SWR. Raising the SWR to 9:1 merely triples the maximum voltage that the line must withstand to 822 V. This voltage is well below the 3700-V rating of RG-11, or the 1700-V rating of RG-59, the two most popular 75-Ω coax lines. Voltage breakdown in the traps is also very unlikely. As will be pointed out later, the operating power levels of these antennas are limited by RF power dissipation in the traps, not trap voltage breakdown or feed-line SWR.

### Trap Losses and Power Rating

**Table 1** presents the results of trap Q measurements and extrapolation by a two-frequency method to higher frequencies above resonance. W8NX employed an old, but recently calibrated, Boonton Q meter for the measurements. Extrapolation to higher-frequency bands assumes that trap resistance losses rise with skin effect according to the square root of frequency, and that trap dielectric losses rise directly with frequency. Systematic measurement errors are not increased by frequency extrapolation. However, random measurement errors increase in magnitude with upward frequency extrapolation. Results are believed to be accurate within 4% on 80 and 40 meters, but only within 10 to 15% at 10 meters. Trap Q is shown at both the high- and low-impedance trap terminals. The Q at the low-impedance output terminals is 15 to 20% lower than the Q at the high-



---

**Table 1****Trap Q**

Frequency (MHz)	3.8	7.15	14.18	18.1	21.3	24.9	28.6
High Z out (W)	101	124	139	165	73	179	186
Low Z out (W)	83	103	125	137	44	149	155

**Table 2****Trap Loss Analysis: 80, 40, 20, 15, 10-Meter Antenna**

Frequency (MHz)	3.8	7.15	14.18	21.3	28.6
Radiation Efficiency (%)	96.4	70.8	99.4	99.9	100.0
Trap Losses (dB)	0.16	1.5	0.02	0.01	0.003

**Table 3****Trap Loss Analysis: 80, 40, 17, 12-Meter Antenna**

Frequency (MHz)	3.8	7.15	18.1	24.9
Radiation Efficiency (%)	89.5	90.5	99.3	99.8
Trap Losses (dB)	0.5	0.4	0.03	0.006

---

impedance output terminals.

W8NX computer-analyzed trap losses for both antennas in free space. Antenna-input resistances at resonance were first calculated, assuming lossless, infinite-Q traps. They were again calculated using the Q values in Table 1. The radiation efficiencies were also converted into equivalent trap losses in decibels. **Table 2** summarizes the trap-loss analysis for the 80, 40, 20, 15 and 10-meter antenna and **Table 3** for the 80, 40, 17 and 12-meter antenna.

The loss analysis shows radiation efficiencies of 90% or more for both antennas on all bands except for the 80, 40, 20, 15 and 10-meter antenna when used on 40 meters. Here, the radiation efficiency falls to 70.8%. A 1-kW power level at 90% radiation efficiency corresponds to 50-W dissipation per trap. In W8NX's experience, this is the trap's survival limit for extended key-down operation. SSB power levels of 1 kW PEP would dissipate 25 W or less in each trap. This is well within the dissipation capability of the traps.

When the 80, 40, 20, 15 and 10-meter antenna is operated on 40 meters, the radiation efficiency of 70.8% corresponds to a dissipation of 146 W in each trap when 1 kW is delivered to the antenna. This is sure to burn out the traps—even if sustained for only a short time. Thus, the power should be limited to less than 300 W when this antenna is operated on 40 meters under prolonged key-down

conditions. A 50% CW duty cycle would correspond to a 600-W power limit for normal 40-meter CW operation. Likewise, a 50% duty cycle for 40-meter SSB corresponds to a 600-W PEP power limit for the antenna.

The author knows of no analysis where the burnout wattage rating of traps has been rigorously determined. Operating experience seems to be the best way to determine trap burn-out ratings. In his own experience with these antennas, he's had no traps burn out, even though he operated the 80, 40, 20, 15 and 10-meter antenna on the critical 40-meter band using his AL-80A linear amplifier at the 600-W PEP output level. He did not make a continuous, key-down, CW operating tests at full power purposely trying to destroy the traps!

Some hams may suggest using a different type of coaxial cable for the traps. The dc resistance of 40.7  $\Omega$  per 1000 feet of RG-59 coax seems rather high. However, W8NX has found no coax other than RG-59 that has the necessary inductance-to-capacitance ratio to create the trap characteristic reactance required for the 80, 40, 20, 15 and 10-meter antenna. Conventional traps with wide-spaced, open-air inductors and appropriate fixed-value capacitors could be substituted for the coax traps, but the convenience, weatherproof configuration and ease of fabrication of coaxial-cable traps is hard to beat.

# Multiband Vertical Antennas

There are two basic types of vertical antennas; either type can be used in multiband configurations. The first is the ground-mounted vertical and the second, the ground plane. These antennas are described in detail in [Chapter 6](#).

The efficiency of any ground-mounted vertical depends a great deal on near-field earth losses. As pointed out in [Chapter 3](#), these near-field losses can be reduced or eliminated with an adequate radial system. Considerable experimentation has been conducted on this subject by Jerry Sevick, W2FMI, and several important results were obtained. It was determined that a radial system consisting of 40 to 50 radials,  $0.2 \lambda$  long, would reduce the earth losses to about  $2 \Omega$  when a  $\lambda/4$  radiator was being used. These radials should be on the earth's surface, or if buried, placed not more than an inch or so below ground. Otherwise, the RF current would have to travel through the lossy earth before reaching the radials. In a multiband vertical system, the radials should be  $0.2 \lambda$  long for the lowest band, that is, 55 feet long for 3.5-MHz operation. Any wire size may be used for the radials. The radials should fan out in a circle, radiating from the base of the antenna. A metal plate, such as a piece of sheet copper, can be used at the center connection.

The other common type of vertical is the ground-plane antenna. Normally, this antenna is mounted above ground with the radials fanning out from the base of the antenna. The vertical portion of the antenna is usually an electrical  $\lambda/4$ , as is each of the radials. In this type of antenna, the system of radials acts somewhat like an RF choke, to prevent RF currents from flowing in the supporting structure, so the number of radials is not as important a factor as it is with a ground-mounted vertical system. From a practical standpoint, the customary number of radials is four or five. In a multiband configuration,  $\lambda/4$  radials are required for each band of operation with the ground-plane antenna.

This is not so with the ground-mounted vertical antenna, where the ground plane is relied upon to provide an image of the radiating section. Note that even quarter-wave-long radials are greatly detuned by their proximity to ground—radial resonance is not necessary or even possible. In the ground-mounted case, so long as the ground-screen radials are approximately  $0.2 \lambda$  long at the lowest frequency, the length will be more than adequate for the higher frequency bands.

## Short Vertical Antennas

A short vertical antenna can be operated on several bands by loading it at the base, the general arrangement being similar to [Figs 1 and 2](#). That is, for multiband work the vertical can be handled by the same methods that are used for random-length wires.

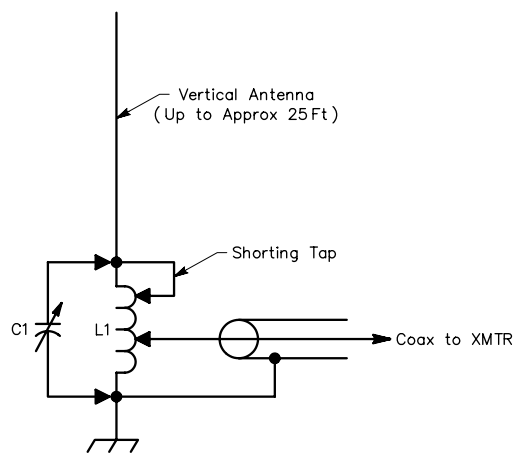
A vertical antenna should not be longer than about  $3/4 \lambda$  at the highest frequency to be used, however, if low-angle radiation is wanted. If the antenna is to be used on 28 MHz and lower frequencies, therefore, it should not be

more than approximately 25 feet high, and the shortest possible ground lead should be used.

Another method of feeding is shown in [Fig 25](#). L1 is a loading coil, tapped to resonate the antenna on the desired band. A second tap permits using the coil as a transformer for matching a coax line to the transmitter. C1 is not strictly necessary, but may be helpful on the lower frequencies, 3.5 and 7 MHz, if the antenna is quite short. In that case C1 makes it possible to tune the system to resonance with a coil of reasonable dimensions at L1. C1 may also be useful on other bands as well, if the system cannot be matched to the feed line with a coil alone.

The coil and capacitor should preferably be installed at the base of the antenna, but if this cannot be done a wire can be run from the antenna base to the nearest convenient location for mounting L1 and C1. The extra wire will of course be a part of the antenna, and since it may have to run through unfavorable surroundings it is best to avoid using it if at all possible.

This system is best adjusted with the help of an SWR indicator. Connect the coax line across a few turns of L1 and take trial positions of the shorting tap until the SWR reaches its lowest value. Then vary the line tap similarly; this should bring the SWR down to a low value. Small



**Fig 25—Multiband vertical antenna system using base loading for resonating on 3.5 to 28 MHz. L1 should be wound with bare wire so it can be tapped at every turn, using #12 wire. A convenient size is  $2\frac{1}{2}$  inches diameter, 6 turns per inch (such as B&W 3029). Number of turns required depends on antenna and ground lead length, more turns being required as the antenna and ground lead are made shorter. For a 25-foot antenna and a ground lead of the order of 5 feet, L1 should have about 30 turns. The use of C1 is explained in the text. The smallest capacitance that will permit matching the coax cable should be used; a maximum capacitance of 100 to 150 pF will be sufficient in any case.**

adjustments of both taps then should reduce the SWR to close to 1:1. If not, try adding C1 and go through the same procedure, varying C1 each time a tap position is changed.

### Trap Verticals

The trap principle described in Fig 13 for center-fed dipoles also can be used for vertical antennas. There are two principal differences. Only one half of the dipole is used, the ground connection taking the place of the missing half,

and the feed-point impedance is one half the feed-point impedance of a dipole. Thus it is in the vicinity of  $30 \Omega$  (plus the ground-connection resistance), so 52- $\Omega$  cable should be used since it is the commonly available type that comes closest to matching.

### A TRAP VERTICAL FOR 21 AND 28 MHz

Simple antennas covering the upper HF bands can be quite compact and inexpensive. The two-band vertical ground plane described here is highly effective for long-distance communication when installed in the clear.

Figs 26, 27 and 28 show the important assembly details. The vertical section of the antenna is mounted on a  $3/4$ -inch thick piece of plywood board that measures  $7 \times 10$  inches. Several coats of exterior varnish or similar material will help protect the wood from inclement weather. Both the mast and the radiator are mounted on the piece of wood by means of TV U-bolt hardware. The vertical is electrically isolated from the wood with a piece of 1-inch diameter PVC tubing. A piece approximately 8 inches long is required, and

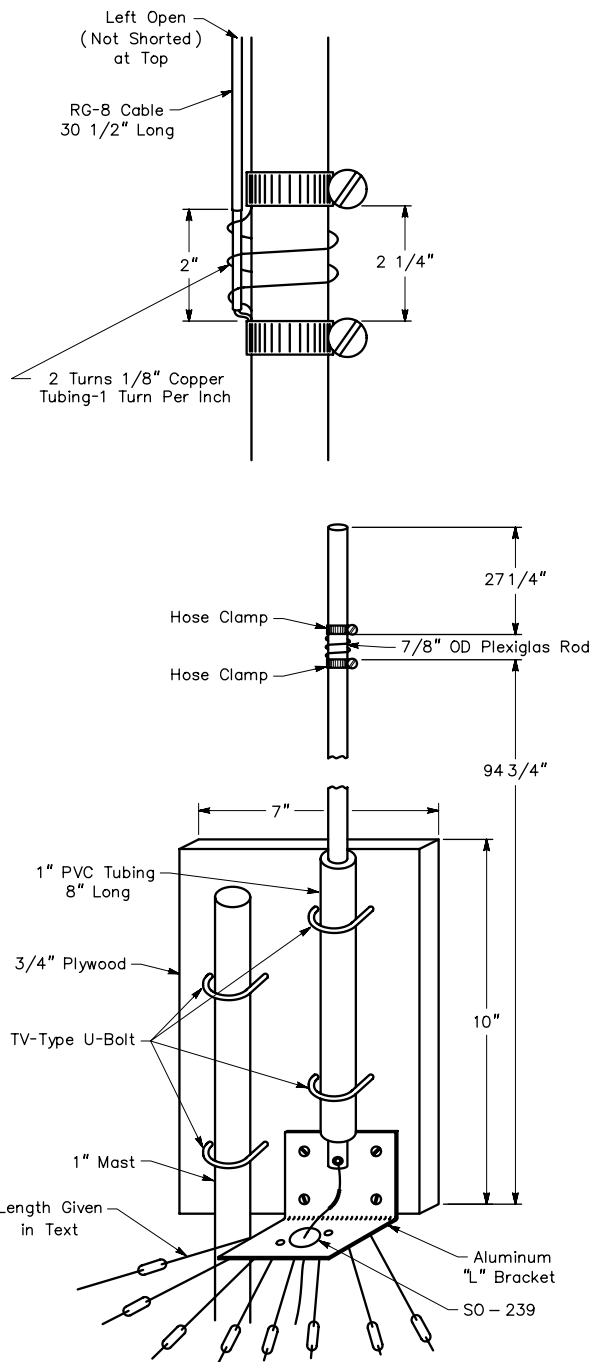


Fig 26—Constructional details of the 21- and 28-MHz dual-band antenna system.

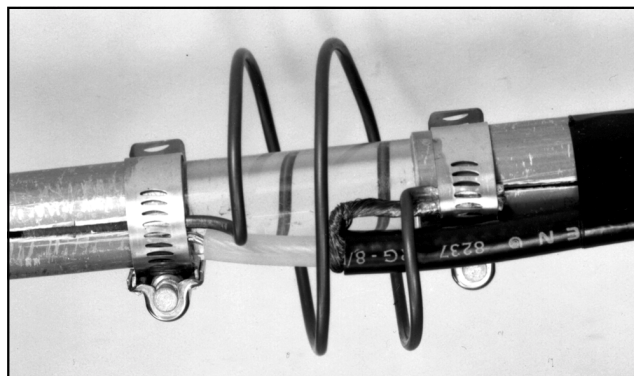


Fig 27—A close-up view of a trap. The coil is 3 inches in diameter. The leads from the coaxial-cable capacitor should be soldered directly to the pigtails of the coil. These connections should be coated with varnish after they have been secured under the hose clamps.

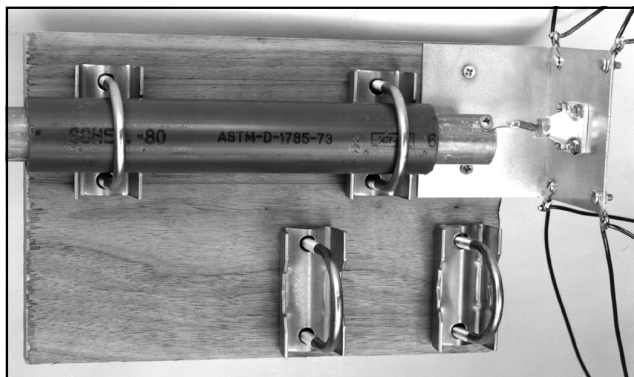


Fig 28—The base assembly of the 21- and 28-MHz vertical. The SO-239 coaxial connector and hood can be seen in the center of the aluminum L bracket. The U bolts are TV-type antenna hardware. The plywood should be coated with varnish or similar material.

it is of the schedule-80 variety. To prepare the tubing, you must slit it along the entire length on one side. A hacksaw will work quite well. The PVC fits rather snugly on the aluminum tubing and will have to be “persuaded” with the aid of a hammer. Mount the mast directly on the wood with no insulation.

Use an SO-239 coaxial connector and four solder lugs on an L-shaped bracket made from a piece of aluminum sheet. Solder a short length of test probe wire, or inner conductor of RG-58 cable, to the inner terminal of the connector. A UG-106 connector hood is then slid over the wire and onto the coaxial connector. Then bolt the hood and connector to the aluminum bracket. Two wood screws are used to secure the aluminum bracket to the plywood, as shown in the drawing and photograph. Solder the free end of the wire coming from the connector to a lug mounted on the bottom of the vertical radiator. Fill any space between the wire and where it passes through the hood with GE silicone sealant or similar material to keep moisture out. The eight radials, four for each band, are soldered to the four lugs on the aluminum bracket. Separate the two sections of the vertical member with a piece of clear acrylic rod. Approximately 8 inches of  $7/8$ -inch OD material is required. You must slit the aluminum tubing lengthwise for several inches so the acrylic rod may be inserted. The two pieces of aluminum tubing are separated by  $2\frac{1}{4}$  inches.

The trap capacitor is made from RG-8 coaxial cable and is 30.5 inches long. RG-8 cable has 29.5 pF of

capacitance per foot and RG-58 has 28.5 pF per foot. RG-8 cable is recommended over RG-58 because of its higher breakdown-voltage capability. The braid should be pulled back 2 inches on one end of the cable, and the center conductor soldered to one end of the coil. Solder the braid to the other end of the coil. Compression type hose clamps are placed over the capacitor/coil leads and put in position at the edges of the aluminum tubing. When tightened securely, the clamps serve a two-fold purpose—they keep the trap in contact with the vertical members and prevent the aluminum tubing from slipping off the acrylic rod. The coaxial-cable capacitor runs upward along the top section of the antenna. This is the side of the antenna to which the braid of the capacitor is connected. Place a cork or plastic cap in the very top of the antenna to keep moisture out.

### Installation and Operation

The antenna may be mounted in position using a TV-type tripod, chimney, wall or vent mount. Alternatively, a telescoping mast or ordinary steel TV mast may be used, in which case the radials may be used as guys for the structure. The 28-MHz radials are 8 feet 5 inches long, and the 21-MHz radials are 11 feet 7 inches.

Any length of 52- $\Omega$  cable may be used to feed the antenna. The SWR at resonance should be on the order of 1.2:1 to 1.5:1 on both bands. The reason the SWR is not 1:1 is that the feed-point resistance is something other than 52  $\Omega$ —closer to 35 or 40  $\Omega$ .

## The Open-Sleeve Antenna

Although only recently adapted for the HF and VHF amateur bands, the open-sleeve antenna has been around since 1946. The antenna was invented by [Dr J. T. Bolljahn](#), of Stanford Research Institute. This section on sleeve antennas was written by Roger A. Cox, WB0DGF.

The basic form of the open-sleeve monopole is shown in [Fig 29](#). The open-sleeve monopole consists of a base-fed central monopole with two parallel closely spaced parasitics, one on each side of the central element, and grounded at each base. The lengths of the parasitics are roughly one half that of the central monopole.

### Impedance

The operation of the open sleeve can be divided into two modes, an antenna-mode and a transmission-line mode. This is shown in [Fig 30](#).

The antenna-mode impedance,  $Z_A$ , is determined by the length and diameter of the central monopole. For sleeve lengths less than that of the monopole, this impedance is essentially independent of the sleeve dimensions.

The transmission-line mode impedance,  $Z_T$ , is determined by the characteristic impedance, end impedance, and length of the 3-wire transmission line formed by the central monopole and the two sleeve elements. The characteristic impedance,  $Z_C$ , can be determined by the

element diameters and spacing if all element diameters are equal, and is found from

$$Z_C = 207 \log 1.59 (D/d) \quad (\text{Eq 2})$$

where

$D$  = spacing between the center of each sleeve element and the center of the driven element

$d$  = diameter of each element

This is shown graphically in [Fig 31](#). However, since the end impedance is usually unknown, there is little need to know the characteristic impedance. The transmission-line mode impedance,  $Z_T$ , is usually determined by an educated guess and experimentation.

As an example, let us consider the case where the central monopole is  $\lambda/4$  at 14 MHz. It would have an antenna mode impedance,  $Z_A$ , of approximately 52  $\Omega$ , depending upon the ground conductivity and number of radials. If two sleeve elements were added on either side of the central monopole, with each approximately half the height of the monopole and at a distance equal to their height, there would be very little effect on the antenna mode impedance,  $Z_A$ , at 14 MHz.

Also,  $Z_T$  at 14 MHz would be the end impedance transformed through a  $\lambda/8$  section of a very high

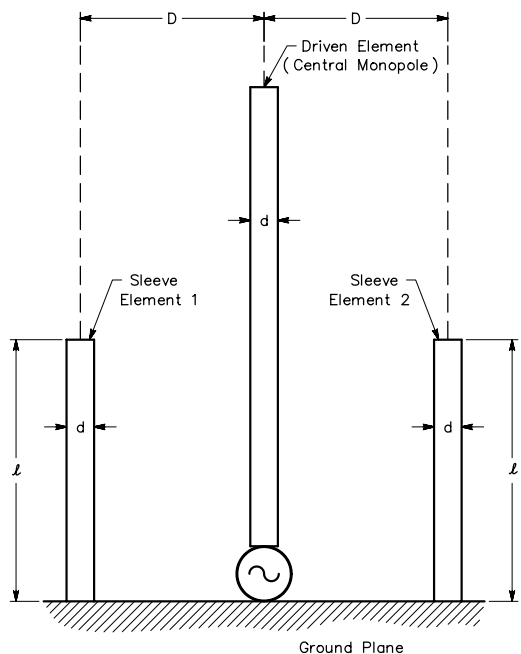


Fig 29—Diagram of an open sleeve monopole.

characteristic impedance transmission line. Therefore,  $Z_T$  would be on the order of 500-2000  $\Omega$  resistive plus a large capacitive reactance component. This high impedance in parallel with 52  $\Omega$  would still give a resultant impedance close to 52  $\Omega$ .

At a frequency of 28 MHz, however,  $Z_A$  is that of an end-fed half-wave antenna, and is on the order of 1000-5000  $\Omega$  resistive. Also,  $Z_T$  at 28 MHz would be on the order of 1000-5000  $\Omega$  resistive, since it is the end impedance of the sleeve elements transformed through a quarter-wave section of a very high characteristic impedance 3-wire transmission line. Therefore, the parallel combination of  $Z_A$  and  $Z_T$  would still be on the order of 500-2500  $\Omega$  resistive.

If the sleeve elements were brought closer to the central monopole such that the ratio of the spacing to element diameter was less than 10:1, then the characteristic impedance of the 3-wire transmission line would drop to less than 250  $\Omega$ . At 28 MHz,  $Z_A$  remains essentially unchanged, while  $Z_T$  begins to edge closer to 52  $\Omega$  as the spacing is reduced. At some particular spacing the characteristic impedance, as determined by the  $D/d$  ratio, is just right to transform the end impedance to exactly 52  $\Omega$  at some frequency. Also, as the spacing is decreased, the frequency where the impedance is purely resistive gradually increases.

The actual impedance plots of a 14/28-MHz open sleeve monopole appear in Figs 31 and 32. The length of the central monopole is 195.5 inches, and of the sleeve elements 89.5 inches. The element diameters range from 1.25 inches

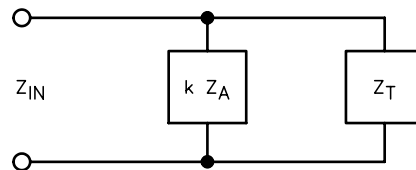


Fig 30—Equivalent circuit of an open sleeve antenna.

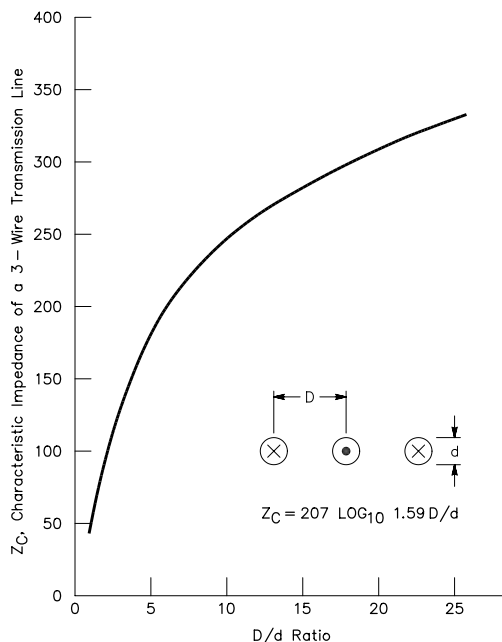


Fig 31—Characteristic impedance of transmission line mode in an open-sleeve antenna.

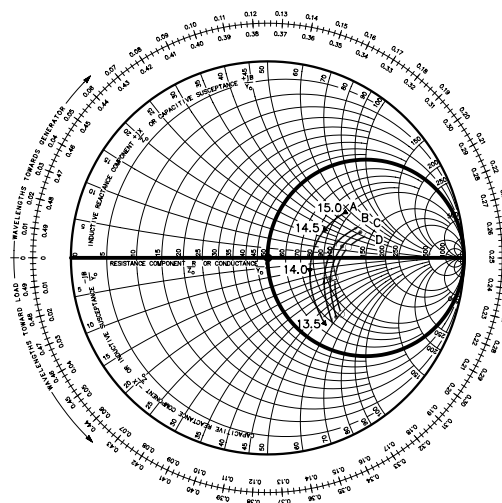


Fig 32—Impedance of an open-sleeve monopole for the frequency range 13.5-15 MHz. Curve A is for a 14 MHz monopole alone. For curves B, C and D, the respective spacings from the central monopole to the sleeve elements are 8, 6 and 4 inches. See text for other dimensions.

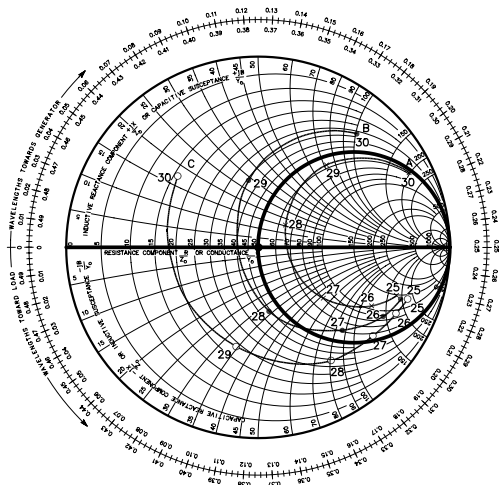
at the bases to 0.875 inch at each tip. The measured impedance of the 14 MHz monopole alone, curve A of Fig 32, is quite high. This is probably because of a very poor ground plane under the antenna. The addition of the sleeve elements raises this impedance slightly, curves B, C and D.

As curves A and B in Fig 33 show, an 8-inch sleeve spacing gives a resonance near 27.8 MHz at 70 Ω, while a 6-inch spacing gives a resonance near 28.5 MHz at 42 Ω. Closer spacings give lower impedances and higher resonances. The optimum spacing for this particular antenna would be somewhere between 6 and 8 inches. Once the spacing is found, the lengths of the sleeve elements can be tweaked slightly for a choice of resonant frequency.

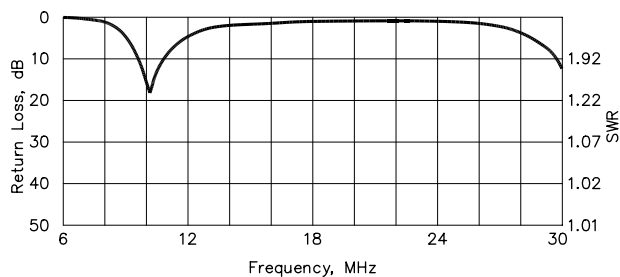
In other frequency combinations such as 10/21, 10/24, 14/21 and 14/24-MHz, spacings in the 6 to 10-inch range work very well with element diameters in the 0.5 to 1.25-inch range.

### Bandwidth

The open-sleeve antenna, when used as a multiband



**Fig 33—Impedance of the open-sleeve monopole for the range 25-30 MHz. For curves A, B and C the spacings from the central monopole to the sleeve elements are 8, 6 and 4 inches, respectively.**



**Fig 34—Return loss and SWR of a 10 MHz vertical antenna. A return loss of 0 dB represents an SWR of infinity. The text contains an equation for converting return loss to an SWR value.**

antenna, does not exhibit broad SWR bandwidths unless, of course, the two bands are very close together. For example, Fig 34 shows the return loss and SWR of a single 10-MHz vertical antenna. Its 2:1 SWR bandwidth is 1.5 MHz, from 9.8 to 11.3 MHz. Return loss and SWR are related as given by the following equation.

$$SWR = \frac{1+k}{1-k} \quad (\text{Eq } 3)$$

where

$$k = 10^{\frac{R_L}{20}}$$

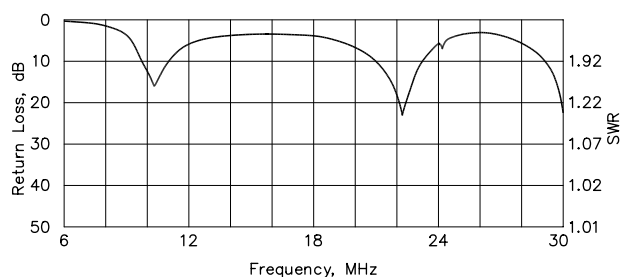
$R_L$  = return loss, dB

When sleeve elements are added for a resonance near 22 MHz, the 2:1 SWR bandwidth at 10 MHz is still nearly 1.5 MHz, as shown in Fig 35. The total amount of spectrum under 2:1 SWR increases, of course, because of the additional band, but the individual bandwidths of each resonance are virtually unaffected.

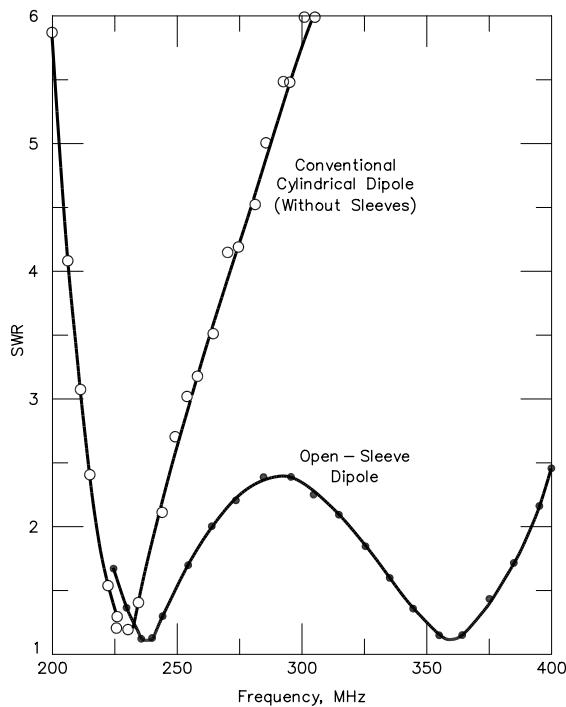
The open-sleeve antenna, however, can be used as a broadband structure, if the resonances are close enough to overlap. With the proper choices of resonant frequencies, sleeve and driven element diameters and sleeve spacing, the SWR “hump” between resonances can be reduced to a value less than 3:1. This is shown in Fig 36.

### Current Distribution

According to H. B. Barkley (see Bibliography at the end of this chapter), the total current flowing into the base of the open-sleeve antenna may be broken down into two components, that contributed by the antenna mode,  $I_A$ , and that contributed by the transmission-line mode,  $I_T$ . Assuming that the sleeves are approximately half the height of the central monopole, the impedance of the antenna mode,  $Z_A$ , is very low at the resonant frequency of the central monopole, and the impedance of the transmission-line mode,  $Z_T$ , is very high. This allows almost all of the current to flow in the antenna mode, and  $I_A$  is very much greater than  $I_T$ . Therefore, the current on the central  $\lambda/4$  monopole assumes the standard sinusoidal variation, and the radiation



**Fig 35—Return loss and SWR of a 10/22 MHz open-sleeve vertical antenna.**



**Fig 36—SWR response of an open-sleeve dipole and a conventional dipole.**

and gain characteristics are much like those of a normal  $\lambda/4$  vertical antenna.

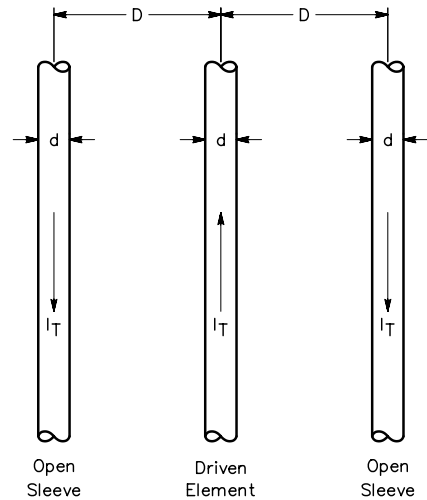
However, at the resonant frequency of the sleeves, the impedance of the central monopole is that of an end fed half-wave monopole and is very high. Therefore  $I_A$  is small. If proper element diameters and spacings have been used to match the transmission line mode impedance,  $Z_T$ , to  $52 \Omega$ , then  $I_T$ , the transmission line mode current, is high compared to  $I_A$ .

This means that very little current flows in the central monopole above the tops of the sleeve elements, and the radiation is mostly from the transmission-line mode current,  $I_T$ , in all three elements below the tops of the sleeve elements. The resulting current distribution is shown in **Figs 37** and **38** for this case.

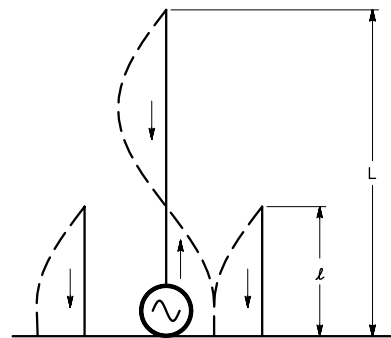
### Radiation Pattern and Gain

The current distribution of the open-sleeve antenna where all three elements are nearly equal in length is nearly that of a single monopole antenna. If, at a particular frequency, the elements are approximately  $\lambda/4$  long, the current distribution is sinusoidal.

If, for this and other length ratios, the chosen diameters and spacings are such that the two sleeve elements approach an interelement spacing of  $\lambda/8$ , the azimuthal pattern will show directivity typical of two in-phase vertical radiators, approximately  $\lambda/8$  apart. If a bi-directional pattern is needed, then this is one way to achieve it.



**Fig 37—Current distribution in the transmission line mode. The amplitude of the current induced in each sleeve element equals that of the current in the central element but the phases are opposite, as shown.**



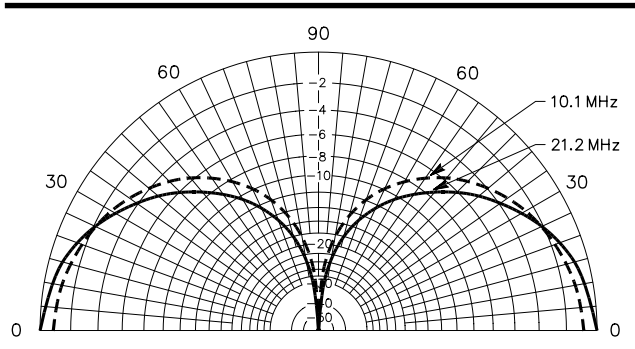
**Fig 38—Total current distribution with  $\lambda = L/2$ .**

Spacings closer than this will produce nearly circular azimuthal radiation patterns. Practical designs in the 10 to 30 MHz range using 0.5 to 1.5-inch diameter elements will produce azimuthal patterns that vary less than  $\pm 1$  dB.

If the ratio of the length of the central monopole to the length of the sleeves approaches 2:1, then the elevation pattern of the open-sleeve vertical antenna at the resonant frequency of the sleeves becomes slightly compressed. This is because of the in-phase contribution of radiation from the  $\lambda/2$  central monopole.

As shown in **Fig 39**, the 10/21-MHz open sleeve vertical antenna produces a lower angle of radiation at 21.2 MHz with a corresponding increase in gain of 0.66 dB over that of the 10-MHz vertical alone.

At length ratios approaching 3:1, the antenna mode and transmission-line mode impedance become nearly equal again, and the central monopole again carries a significant



**Fig 39—Vertical-plane radiation patterns of a 10/21 MHz open-sleeve vertical antenna on a perfect ground plane. At 10.1 MHz the maximum gain is 5.09 dBi, and 5.75 dBi at 21.2 MHz.**

portion of the antenna current. The radiation from the top  $\lambda/2$  combines constructively with the radiation from the  $\lambda/4$  sleeve elements to produce gains of up to 3 dB more than just a quarter-wave vertical element alone.

Length ratios in excess of 3.2:1 produce higher level sidelobes and less gain on the horizon, except for narrow spots near the even ratios of 4:1, 6:1, 8:1, etc. These are where the central monopole is an even multiple of a half-wave, and the antenna-mode impedance is too high to allow much antenna-mode current.

Up to this point, it has been assumed that only  $\lambda/4$  resonance could be used on the sleeve elements. The third, fifth, and seventh-order resonances of the sleeve elements and the central monopole element can be used, but their radiation patterns normally consist of high-elevation lobes, and the gain on the horizon is less than that of a  $\lambda/4$  vertical.

### Practical Construction and Evaluation

The open-sleeve antenna lends itself very easily to home construction. For the open-sleeve vertical antenna, only a feed-point insulator and a good supply of aluminum tubing are needed. No special traps or matching networks are required. The open-sleeve vertical can produce up to 3 dB more gain than a conventional  $\lambda/4$  vertical. Further, there is no reduction in bandwidth, because there are no loading coils.

The open-sleeve design can also be adapted to horizontal dipole and beam antennas for HF, VHF and UHF. A good example of this is Telex/Hy-Gain's Explorer 14 triband beam which utilizes an open sleeve for the 10/15-meter driven element. The open-sleeve antenna is also very easy to model in computer programs such as *NEC* and *MININEC*, because of the open tubular construction and lack of traps or other intricate structures.

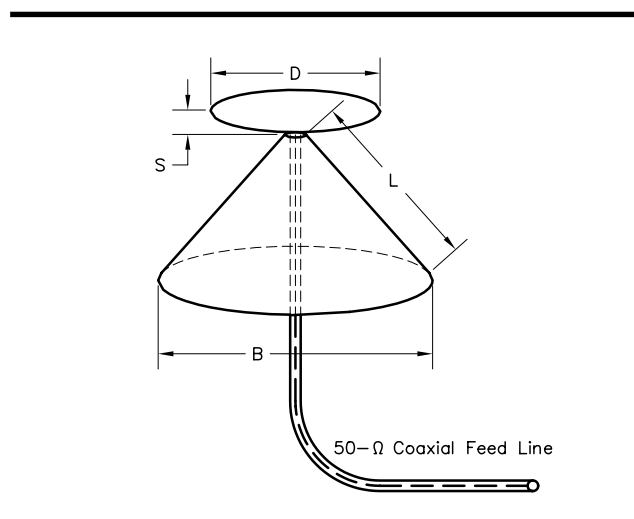
In conclusion, the open-sleeve antenna is an antenna experimenter's delight. It is not difficult to match or construct, and it makes an ideal broadband or multiband antenna.

## HF Discone Antennas

The material in this section is adapted from an article by Daniel A. Krupp, W8NWF, in *The ARRL Antenna Compendium, Vol 5*. The name *discone* is a contraction of the words disc and cone. Although people often describe a discone by its design-center frequency (for example, a "20-meter discone"), it works very well over a wide frequency range, as much as several octaves. **Fig 40** shows a typical discone, constructed of sheet metal for UHF use. On lower frequencies, the sheet metal may be replaced with closely spaced wires and/or aluminum tubing.

The dimensions of a discone are determined by the lowest frequency of use. The antenna produces a vertically polarized signal at a low-elevation angle and it presents a good match for 50- $\Omega$  coax over its operating range. One advantage of the discone is that its maximum current area is near the top of the antenna, where it can radiate away from ground clutter. The cone-like skirt of the discone radiates the signal—radiation from the disc on top is minimal. This is because the currents flowing in the skirt wires essentially all go in the same direction, while the currents in the disc elements oppose each other and cancel out. The discone's omnidirectional characteristics make it ideal for roundtable QSOs or for a Net Control station.

Electrical operation of this antenna is very stable, with no changes due to rain or accumulated ice. It is a self-



**Fig 40—Diagram of VHF/UHF discone, using a sheet-metal disc and cone. It is fed directly with 50- $\Omega$  coax line. The dimensions L and D, together with the spacing S between the disc and cone, determine the frequency characteristics of the antenna.  $L = 246 / f_{\text{MHz}}$  for the lowest frequency to be used. Diameter D should be from 0.67 to 0.70 of dimension L. The diameter at the bottom of the cone B is equal to L. The space S between disc and cone can be 2 to 12 inches, with the wider spacing appropriate for larger antennas.**



contained antenna—unlike a traditional ground-mounted vertical radiator, the disccone does not rely on a ground-radial system for efficient operation. However, just like any other vertical antenna, the quality of the ground in the Fresnel area will affect the disccone’s far-field pattern.

Both the disc and cone are inherently balanced for wind loading, so torque caused by the wind is minimal. The entire cone and metal mast or tower can be connected directly to ground for lightning protection.

Unlike a trap vertical or a triband beam, disccone antennas are not adjusted to resonate at a particular frequency in a ham band or a group of ham bands. Instead, a disccone functions as a sort of high-pass filter, efficiently radiating RF all the way from the low-frequency design cutoff to the high-frequency limits imposed by the physical design.

While VHF disccones have been available out-of-the-box for many years, HF disccones are rare indeed. Some articles have dealt with HF disccones, where the number of disc elements and cone wires was minimized to cut costs or to simplify construction. While the minimalist approach is fine if the sought-after results really are obtained, W8NWF believes in building his disccones without compromise.

### History of the Disccone

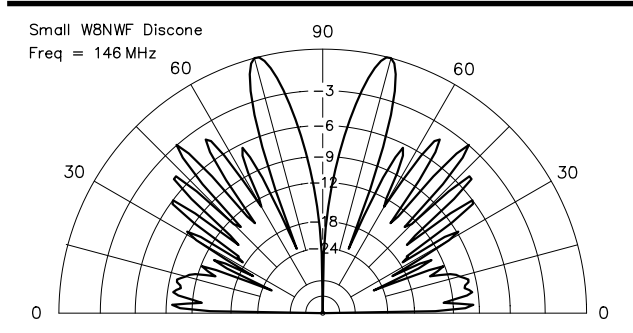
The July 1949 and July 1950 issues of *CQ* magazine both contained excellent articles on disccones. The first article, by [Joseph M. Boyer, W6UYH](#), said that the disccone was developed and used by the military during World War II. (See Bibliography.) The exact configuration of the top disc and cone was the brainchild of [Armig G. Kandonian](#). Boyer described three VHF models, plus information on how to build them, radiation patterns, and most importantly, a detailed description of how they work. He referred to the disccone as a type of “coaxial taper transformer.”

The July 1950 article was by [Mack Seybold, W2RYI](#). He described an 11-MHz version he built on his garage roof. The mast actually fit through the roof to allow lowering the antenna for service. Seybold stated that his 11-MHz disccone would load up on 2 meters but that performance was down 10 dB compared to his 100-MHz Birdcage disccone. He commented that this was caused by the relatively large spacing between the disc and cone. Actually, the performance degradation he found was caused by the wave angle lifting upward at high frequencies. The cone wires were electrically long, causing them to act like long wire antennas. See [Fig 41](#).

### W8NWF’s First Disccone: the A-Frame Disccone

The first disccone was one designed to cover 20 through 10 meters without requiring an antenna tuner. The cone assembly uses 18-foot long wires, with a 60° included apex angle and a 12-foot diameter disc assembly. See [Fig 42](#) and [Fig 43](#). The whole thing was assembled on the ground, with the feed coax and all guys attached. Then with the aid of some friends, it was pulled up into position.

The author used a 40-foot tall wooden “A-frame” mast, made of three 22-foot-long 2 × 4s. He primed the mast with sealer and then gave it two coats of red barn paint to make it



**Fig 41—Computed elevation plot over average ground for W8NWF’s small disccone at 146 MHz, ten times its design frequency range. The cone wires are acting as long-wire antennas, distorting severely the low-elevation angle response, even though the feed-point impedance is close to 50 Ω.**

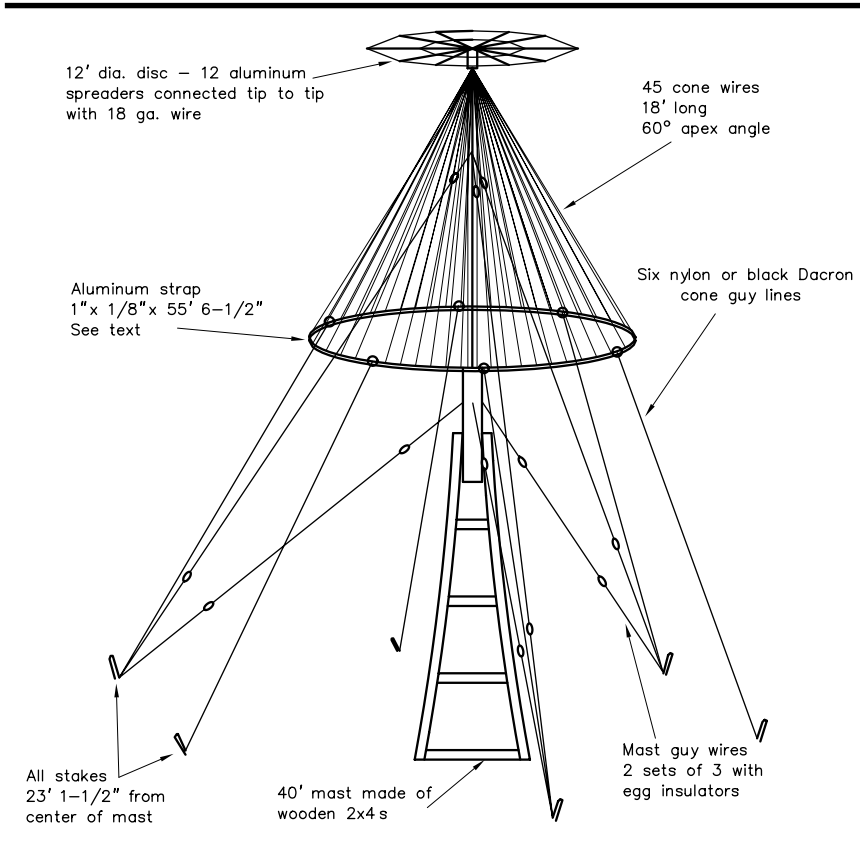


**Fig 42—Photo of W8NWF’s original A-frame mounted HF disccone.**

look nice and last a long time. The disc hub was a 12-inch length of 3-inch schedule-40 PVC plumbing pipe. The PVC is very tough, slightly ductile, and easy to drill and cut. PVC is well suited for RF power at the feed point of the antenna.

Three 12-foot by 0.375-inch OD pieces of 6061 aluminum, with 0.058-inch wall thickness, were used for the 12-foot diameter top disc. These were cut in half to make the center portions of the six telescoping spreaders. Four twelve foot by 0.250-inch OD (0.035-inch wall thickness) tubes were cut into 12 pieces, each 40 inches long. This gave extension tips for each end of the six spreaders.

See [Fig 44](#) for details on the disc hub assembly. W8NWF started by drilling six holes straight through the



**Fig 43—Detailed drawing of the A-frame discone for 14 to 30 MHz. The disc assembly at the top of the A-frame is 12 feet in diameter. There are 45 cone wires, each 18 feet long, making a 60° included angle of the cone. This antenna works very well over the design frequency range.**

inches. For convenience, place the whole mast assembly in a horizontal position on top of two clothesline poles and one stepladder.

Place the disc head assembly over the top of the mast, but don't secure it yet. This allows for rotation while adding the disc spreader extensions. A tip for safety: tie white pieces of cloth to the ends of elements near eye level. Just remember to remove them before raising the antenna.

For a long-lasting installation, use an anti-corrosion compound, such as Penetrox, when assembling the

PVC for the six spreaders, accurately and squarely, starting about two inches down from the top and spaced radially every 30°. Each hole is 0.375 inches below the plane of the previous one. Take great care in drilling—a poor job now will look bad from the ground up for a long time! It's a good idea to make up a paper template beforehand. Tape this to the PVC hub and then drill the holes, which should make for a close fit with the elements. If you goof, start over with a new piece of PVC—it's cheap.

Each six-foot spreader tube was secured exactly in the center to clear a 6-32 threaded brass rod that secured the elements mechanically and electrically. A two-foot long by 1/4-inch OD wooden dowel was inserted into the middle of each six-foot length of tubing. The dowel added strength and also prevented crushing the element when the nuts on the threaded rod were tightened.

Insert the 40-inch long extensions four inches into each end of the six-foot spreaders. Mark and drill holes to pin the telescoping tips, plus holes big enough to clear #18 soft-drawn copper wire. This was for the inner circumferential wire for the disc. Drill a single hole for #18 wire about 1/4 inch from each extension element tip, through which passes the outer circumferential wire. Finally, insert all six-foot elements into the PVC hub and line up the holes in the center so the brass rod could be inserted through the middle to secure the elements.

The next step is to "chisel to fit" the top of the wooden mast to allow the PVC to slide down on it about six or seven

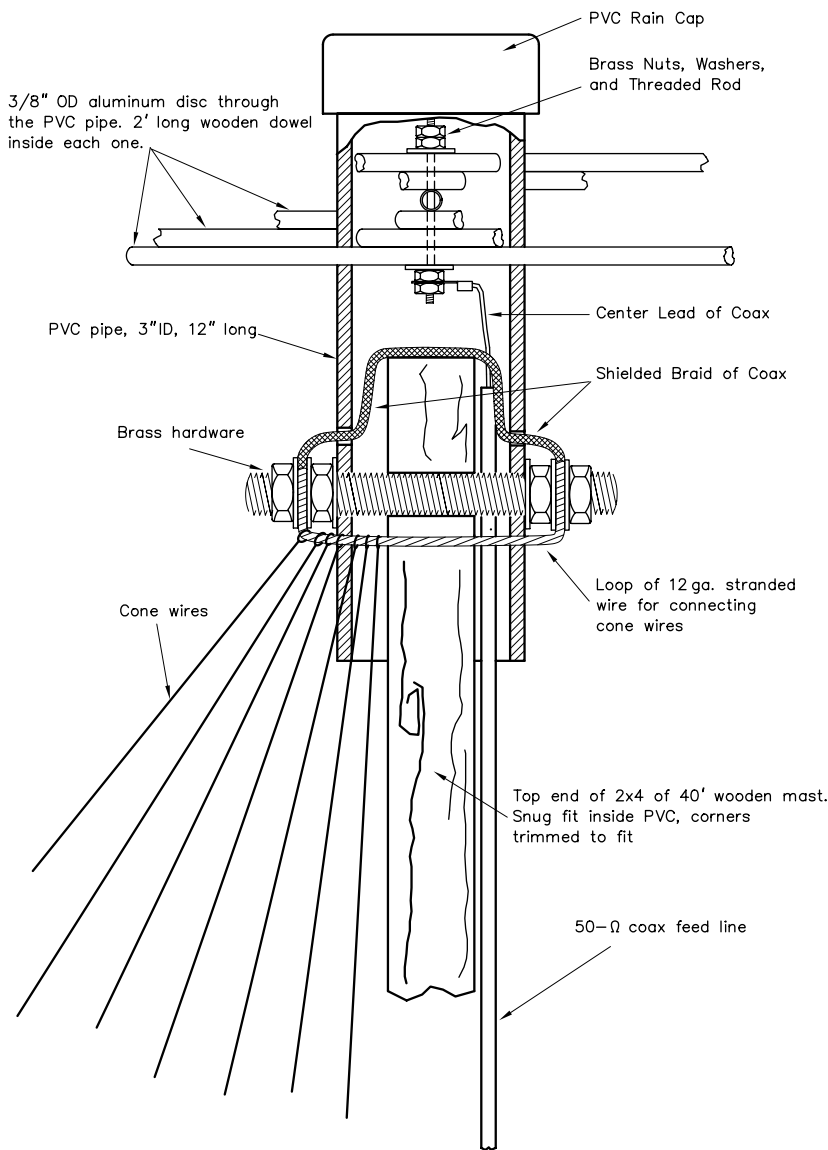
aluminum antenna elements. As the extensions are added, secure them in the innermost of the two holes with a short piece of #18 wire. Then run a wire through the remaining holes looping each element as you go. This gives added support laterally to the elements. Next add a #18 wire to the tips of the extensions in the same fashion. This provides even more physical stability as well as making electrical connections.

Next, pin the PVC disk hub to the wooden mast with a 3/8-inch threaded rod. This is also the point where the cone wires are attached, using a loop of #12 stranded copper wire around the PVC. Solder each cone wire to this loop, together with the coax shield braid. Make sure the loop of #12 wire is large enough to make soldering possible without burning the PVC with the soldering iron.

Connect the coax center conductor to the disc assembly by securing it with the same 6-32 threaded rod that ties all the disc elements together. Make sure to use coax-seal compound to keep moisture out of the coax. The coax is then fed down the mast and secured in a few places to provide strain relief and to keep it out of the way of the cone wires.

Use two sets of three guy wires. Break these up with egg insulators, just to be sure there won't be any interaction with the antenna. Use 45 wires of #18 soft-drawn copper wire for the cone, 18 feet long each. Cut them a little long so they can be soldered to the connecting loop.

A difficult task is now at hand—keeping all the cone wires from getting tangled! Solder each of the 45 cone wires



**Fig 44—Details of the top hub for the A-frame discone. The three-inch PVC pipe was drilled to hold the six spreaders making up the top disc. Connections for the shield of the feed coax were made to the disc. The coax center conductor was connected to the cone-wire assembly by means of a loop of #12 stranded wire encircling the outside of the PVC hub.**

checking that all hardware is tight. A rain cap at the top of the PVC disc hub completes construction.

### Putting It All Up

You are going to need a lot of help now to raise the antenna. Have the whole process fully thought out before trying to raise it. You should have the spot selected for the base of the mast and some pipes driven into the ground to prevent the mast from slipping sideways as it is being pulled up. The three guy stakes should be in place, 23 feet, 1½ inches from mast center. Of course, the guys should have been cut to the correct length, with some extra. Be sure the coax transmission line will come off the mast where it should. A long length of rope to an upper and lower guy line is used to pull up the whole works.

The author used an old trick of standing an extension ladder vertically near the antenna base with the pull lines looped over the top rung to get a good lift angle. The weight added to the mast

from the antenna disc assembly and cone wires is about 26 pounds, most of it from the cone assembly. Use two strong people to pull up the antenna slowly so that the other helpers on the guy wires and cone guy lines have time to move about as required. As the antenna rises to the vertical position, if there are no snafus, the guy lines can be secured. Then tie the six cone lines to stakes.

### A Really Big Discone

When an opportunity arose to buy a 64-foot self-supporting TV tower, the author jumped at the chance to implement a full 7 to 30-MHz discone. His new tower had eight sections, each eight feet long. Counting the overlap between sections, the cone wires would come off the tower at about the 61.5-foot mark.

W8NWF took some liberties with the design of this larger discone compared to the first one, which he had done

to the loop of #12 wire, spacing each wire about ¼ inch from the last one for an even distribution all the way around.

The cone base is 18 feet in diameter to provide a 60° included angle. At the base of the cone, use five 12-foot long aluminum straps, 1 inch wide by ⅛ inch thick, overlapping 8¼ inches and fastened together with aluminum rivets. Drill holes along the strap every 15 inches to secure the cone wires.

Make sure to handle the aluminum strap carefully while fastening the cone wire ends; too sharp of a bend could possibly break it. Fasten six small-diameter nylon lines to the cone-base aluminum strap to stabilize the cone. These cone-guys share the same guy stakes as the mast guy lines. After cutting the nylon lines, heat the frayed ends of each with a small flame to prevent unraveling. Apply several coats of clear protective spray to the disk head assembly, after

strictly “by the book.” The first change was to make the cone wires 70 feet long, even though the formula said they should be 38 feet long. Further, the cone wires would not be connected together at the bottom. With the longer cone wires, he felt that 75 and 80-meter operation might be a possibility.

The second major change was to widen the apex angle out from 60° to about 78°. Modeling said this should produce a flatter SWR over the frequency spectrum and would also give a better guy system for the tower.

The topside disc assembly would be 27 feet in diameter and have 16 radial spreaders, using telescoping aluminum tubing tapering from  $\frac{5}{8}$  to  $\frac{1}{2}$  to  $\frac{3}{8}$  inches OD. All spreaders were made from 0.058-inch wall thickness 6063-T832 aluminum tubing, available from Texas Towers. A section of 10-inch PVC plumbing pipe would be used as the hub for construction of the disc assembly.

### Construction Details for the Large Discone

While installing the tower, the author had left the top section on the ground. This allowed him to fit the disc head assembly precisely to it. **Fig 45** shows the overall plan for the large discone. The 10-inch diameter PVC hub was designed to slip over the tower top section, but was a little too large. So a set of shims was installed on the three legs at the top of the tower for a just-right fit. Drilling the PVC pipe for the eight  $\frac{5}{8}$ -inch OD elements was started about an inch down from the top. W8NWF purposely staggered the drilled holes in the same fashion as the hub for the smaller antenna. See **Fig 46**.

Again, three foot sections of  $\frac{1}{2}$ -inch wooden dowel were used to strengthen the  $\frac{5}{8}$ -inch center portion of each spreader. Instead of using a loop of #12 wire for the connecting the cone wires, as had been done on the smaller discone, he drilled 36 holes in the PVC hub. These holes are small enough so that the PVC hub would not be weakened appreciably. He drilled the circles of holes for the cone wires about six inches below the disc spreaders.

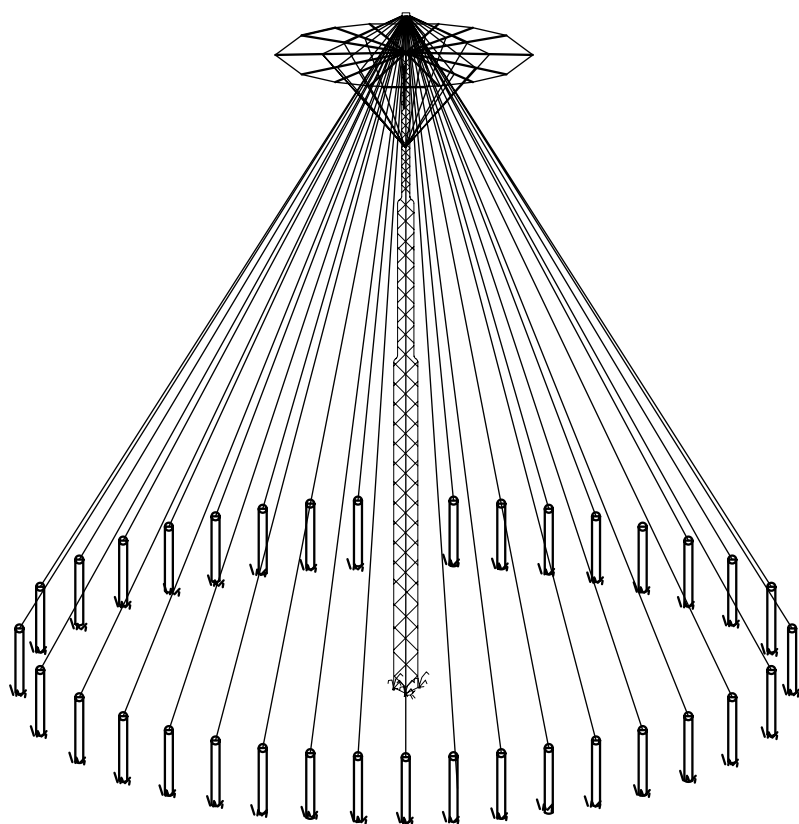
He prepared a three-foot long piece of RG-213 coax, permanently fastened on one end to the antenna, with a female type-N connector at the other end. Type-N fittings were used because of their superior waterproofing abilities. The coax center lead was connected with a terminal lug under a nut on the brass threaded rod securing the disc spreaders. The coax shield braid was folded back over a six-inch long copper pipe and clamped to it with a stainless-steel hose clamp. See **Fig 47** for details.

The plan was that after the top disc assembly had been hoisted up and attached at the top of the tower, individual cone wires would be fed, one at a time, through the small holes drilled in the PVC. They were to be laid against the copper pipe and secured with stainless-steel hose clamps.

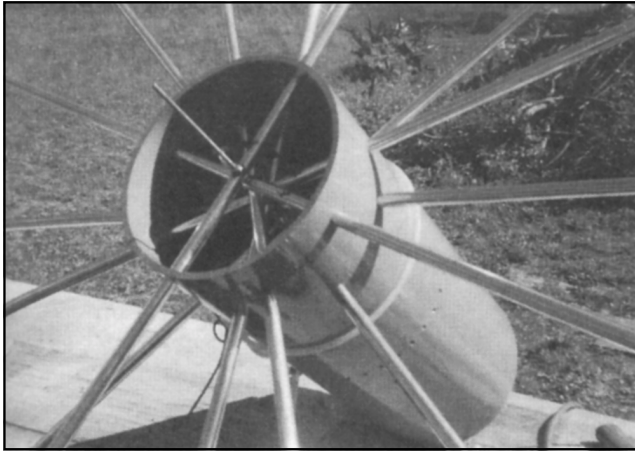
The  $\frac{1}{2}$  and  $\frac{3}{8}$ -inch OD spreader extension tips were secured in place with two aluminum pop-rivets at each joint. Again, the author used anti-oxidant compound on all spreader junctions. He drilled a hole horizontally near the tip of each  $\frac{3}{8}$ -inch tip all around the perimeter to allow a #8 aluminum wire to circle the entire disc. A small stainless-steel sheet-metal screw was threaded into the end of each element to secure the wire.

In parallel with the aluminum wire, a length of small-diameter black Dacron line was run, securing it in a couple of places between each set of spreaders with UV-resistant plastic tie-wraps. The reason for doing this was to hold the aluminum wire in position and to prevent it from dangling, in case it should break some years in the future. Two coats of clear protective spray were applied for protection.

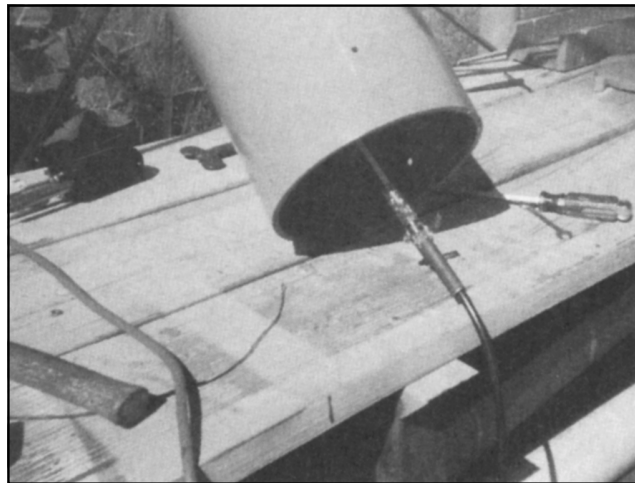
A truss system helps prevent the disc from sagging due to its own weight. See **Fig 48** for details. This shows the completed disk assembly mounted on the top of the tower. A three-foot length of two-inch PVC pipe was used for a truss mast above the disc assembly, notching the bottom of the pipe so that it would form a saddle over the top couple of spreaders. This gave a good foothold. He



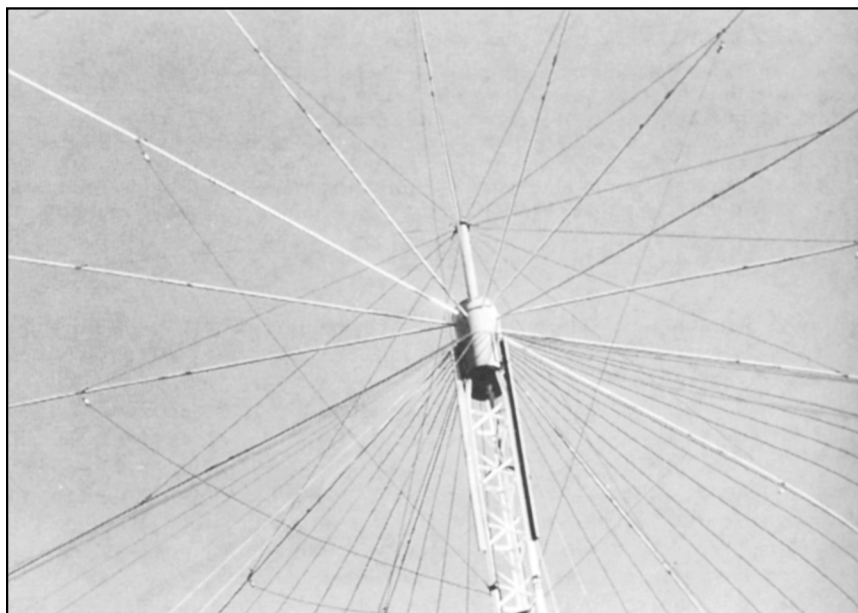
**Fig 45**—The large W8NWF discone, designed for operation from 7 to 14 MHz, but usable with a tuning network in the shack for 3.8 MHz.



**Fig 46—Photo showing details of the hub assembly for the large dish, including the threaded brass rod that connects the radial spreaders together. The 10-inch PVC pipe is drilled to accommodate the radial spreaders. Each spreader is reinforced with a three-foot long wooden dowel inside for crush resistance. Note the row of holes drilled below the lowest spreader. Each of the 36 cone wire passes through one of these holes.**



**Fig 47—Details of the copper pipe slipped over the feed coax. The coax shield has been folded back over the copper pipe and secured with two stainless-steel hose clamps. The cone wires are also laid against the copper pipe and secured with additional hose clamps.**



**Fig 48—Photo of the spreader hub assembly, showing the truss ropes above and below the radial spreaders. This is a very rugged assembly!**

cut a circle of thin sheet aluminum to fit over the 10-inch PVC to serve as a rain cap. The cap has a hole in the center for the two-inch PVC truss mast to pass through, thereby holding it down tight. The author sprayed a few light coats of paint over the PVC for protection from ultraviolet radiation from the sun.

Sixteen small-diameter black Dacron ropes were connected at the top of the truss support mast, with the other ends fastened to the disc spreaders, halfway out. Another rain cap was added to the top of the two-inch PVC truss mast. Eight lengths of the same small diameter Dacron rope were added halfway out the length of every other spreader. These ropes are meant to be tied back to the tower, to prevent updrafts from blowing the disc assembly upwards. Small egg insulators were used near the spot where the eight bottom trusses were tied to the disc spreaders, just to be sure there would be no RF leakage in rainy weather.

Hoisting the completed disc assembly to the top of the tower can be done easily, with the assistance of at least two others. The trickiest part is to get the disc assembly from its position sitting flat on the ground to the vertical position needed for hoisting it up the tower without damaging it. The disc assembly weighs about 35 pounds. Someone at the top of the tower will receive the disc as it is hoisted up by gin pole, and can mount it on the tower top.

You should prepare three six-foot long metal braces going over the outside of the PVC to fasten to the tower legs. They really beef things up.

In plastic irrigation pipe buried between the house and tower base, the author ran 100 feet of 9086 low-loss coax to the shack. For cone wires, he was able to obtain some #18 copperclad steel wire, with heavy black insulation that looked a lot like neoprene. The cone system takes a lot of wire:  $36 \times 70 \text{ feet} = 2520 \text{ feet}$ , plus some extra at each end for termination. You'd be well advised to look around at hamfests to save money.

As each cone wire is connected at the top of the tower, a helper should

place the other end at its proper spot below. The lower end of each cone wire is secured to an insulator screwed into a fencepost. See **Fig 49**. There are 36 treated-pine fenceposts, each standing about 5½ feet tall, 45 feet from the tower base to hold the lower end of the cone wires. This makes mowing the grass easier and the cone wires are less likely to be tripped over too.

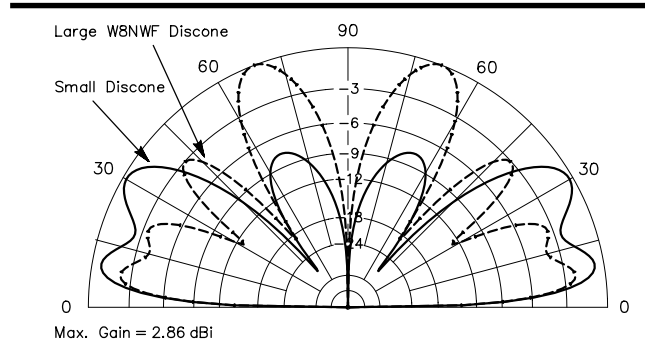
On the final trip down the tower, the eight Dacron downward-truss lines were tied back to the tower about six feet below the disc assembly. The author's tower has three ground rods driven near the base, connected with heavy copper wire to the three tower legs.

### Performance Tests

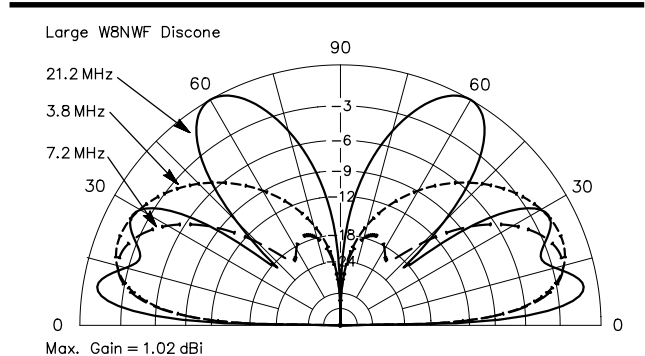
On the air tests proved to be very satisfying. Loading up on 40 meters was easy—the SWR was 1:1 across the entire band. W8NWF can work all directions very well and receives excellent signal reports from DX stations. When he switches to his long (333 foot) center-fed dipole for comparison, he finds the dipole is much noisier and that received signals are weaker. During the daytime, nearby stations (less than about 300 to 500 miles) can be louder with the dipole, but the discone can work them just fine also.

The author happily reports that this antenna even works well on 75 meters. As you might expect, it doesn't present a 1:1 match. However, the SWR is between 3.5:1 and 5.5:1 across the band. W8NWF uses an antenna tuner to operate the discone on 75. It seems to get out as well on 75 as it does on 40 meters.

The SWR on 30 meters is about 1.1:1. On 20 meters the SWR runs from 1.05:1 at 14.0 MHz to 1.4:1 at 14.3 MHz. The SWR on the 17, 15, 12 and 10-meter bands varies, going up to a high of 3.5:1 on 12 meters.



**Fig 50—Computed patterns showing elevation response of small discone at 28.5 MHz compared to that of the larger discone at 28.5 MHz. The cone wires are clearly too long for efficient operation on 10 meters, producing unwanted high-angle lobes that rob power from the desirable low-elevation angles.**



**Fig 51—Computed elevation-response patterns for the larger W8NWF discone for 3.8, 7.2 and 21.2 MHz operation. Again, as in Fig 50, the pattern degrades at 21.2 MHz, although it is still reasonably efficient, if not optimal.**



**Fig 49—Photo showing some of the fence posts used to hold individual cone wires to keep them off the ground and out of harm's way. The truck in the background is carting away the A-frame discone for installation at KA8UNO's QTH.**

## Radiation Patterns for the Discones

From modeling using *NEC/Wires* by K6STI, W8NWF verified that the low-angle performance for the bigger antenna is worse than that for the smaller discone on the upper frequencies. See **Fig 50** for an elevation-pattern comparison on 10 meters for both antennas, with average ground constants. The azimuth patterns are simply circles. Radiation patterns produced by antenna modeling programs are very helpful to determine what to expect from an antenna.

The smaller discone, which was built by the book, displays good, low-angle lobes on 20 through 10 meters. The frequency range of 14 through 28 MHz is an octave's worth of coverage. It met expectations in every way by covering this frequency span with low SWR and a low angle of radiation.

The bigger discone, with a modified cone suitable for use on 75 meters, presents a little different story. The low-angle lobe on 40 meters works well, and 75 meter performance also is good, although an antenna tuner is necessary on this band. The 30-meter band has a good low-angle lobe but secondary high-angle lobes are starting to

hurt performance. Note that 30 meters is roughly three times the design frequency of the cone. On 20 and 17 meters there still are good low-angle lobes but more and more power is wasted in high-angle lobes.

The operation on 15, 12, and 10 meters continues to worsen for the larger discone. The message here is that although a discone may have a decent SWR as high as 10 times the design frequency, its radiation pattern is not necessarily good for low-angle communications. See **Fig 51** for a comparison of elevation patterns for 3.8, 7.2 and 21.2 MHz on the larger discone.

A discone antenna built according to formula will work predictably and without any adjustments. One can modify the antenna's cone length and apex angle without fear of rendering it useless. The broadband feature of the discone makes it attractive to use on the HF bands. The low angle of radiation makes DX a real possibility, and the discone is also much less noisy on receive than a dipole.

Probably the biggest drawback to an HF discone is its bulky size. There is no disguising this antenna! However, if you live in the countryside you should be able to put up a nice one.

## Harmonic Radiation from Multiband Antennas

Since a multiband antenna is intentionally designed for operation on a number of different frequencies, any harmonics or spurious frequencies that happen to coincide with one of the antenna resonant frequencies will be radiated with very little, if any, attenuation. Particular care should be exercised, therefore, to prevent such harmonics from reaching the antenna.

Multiband antennas using tuned feeders have a certain inherent amount of built-in protection against such radiation, since it is nearly always necessary to use a tuned coupling circuit (antenna tuner) between the transmitter and the feeder. This adds considerable selectivity to the system and helps

to discriminate against frequencies other than the desired one.

Multiple dipoles and trap antennas do not have this feature, since the objective in design is to make the antenna show as nearly as possible the same resistive impedance in all the amateur bands the antenna is intended to cover. It is advisable to conduct tests with other amateur stations to determine whether harmonics of the transmitting frequency can be heard at a distance of, say, a mile or so. If they can, more selectivity should be added to the system since a harmonic that is heard locally, even if weak, may be quite strong at a distance because of propagation conditions.

### BIBLIOGRAPHY

Source material and more extended discussion of topics covered in this chapter can be found in the references given below and in the textbooks listed at the end of Chapter 2.

- H. B. Barkley, *The Open-Sleeve As A Broadband Antenna*, Technical Report No. 14, U.S. Naval Postgraduate School, Monterey, CA, Jun 1955.
- W. M. Bell, "A Trap Collinear Antenna," *QST*, Aug 1963, pp 30-31.
- J. S. Belrose, "The HF Discone Antenna," *QST*, Jul 1975, pp 11-14, 56.
- J. Belrose and P. Bouliane, "The Off-Center-Fed Dipole Revisited: A Broadband, Multiband Antenna," *QST*, Oct 1990, p 40.

- H. J. Berg, "Multiband Operation with Paralleled Dipoles," *QST*, Jul 1956.
- E. L. Bock, J. A. Nelson and A. Dorne, "Sleeve Antennas," *Very High Frequency Techniques*, H. J. Reich, ed. (New York: McGraw-Hill, 1947), Chap 5.
- J. T. Bolljahn and J. V. N. Granger, "Omnidirectional VHF and UHF Antennas," *Antenna Engineering Handbook*, H. Jasik, ed. (New York: McGraw-Hill, 1961) pp 27-32 through 27-34.
- J. M. Boyer, W6UYH, "Discone—40 to 500 Mc Skywire," *CQ*, July 1949, p 11.
- G. H. Brown, "The Phase and Magnitude of Earth Currents Near Radio Transmitting Antennas," *Proc. IRE*, Feb 1935.

- G. H. Brown, R. F. Lewis and J. Epstein, "Ground Systems as a Factor in Antenna Efficiency," *Proc. IRE*, Jun 1937, pp 753-787.
- C. L. Buchanan, "The Multimatch Antenna System," *QST*, Mar 1955.
- R. A. Cox, "The Open-Sleeve Antenna," *CQ*, Aug 1983, pp 13-19.
- D. DeMaw, "Lightweight Trap Antennas—Some Thoughts," *QST*, Jun 1983, p 15.
- W. C. Gann, "A Center-Fed 'Zepp' for 80 and 40," *QST*, May 1966.
- D. Geiser, "An Inexpensive Multiband VHF Antenna," *QST*, Dec 1978, pp 28-29.
- A. Greenberg, "Simple Trap Construction for the Multiband Antenna," *QST*, Oct 1956.
- G. L. Hall, "Trap Antennas," Technical Correspondence, *QST*, Nov 1981, pp 49-50.
- W. Hayward, "Designing Trap Antennas," Technical Correspondence, *QST*, Aug 1976, p 38.
- R. H. Johns, "Dual-Frequency Antenna Traps," *QST*, Nov 1983, p 27.
- A. G. Kandonian, "Three New Antenna Types and Their Applications," *Proc IEE*, Vol 34, Feb 1946, pp 70W-75W.
- R. W. P. King, *Theory of Linear Antennas* (Cambridge, MA: Harvard Univ Press, 1956), pp 407-427.
- W. J. Lattin, "Multiband Antennas Using Decoupling Stubs," *QST*, Dec 1960.
- W. J. Lattin, "Antenna Traps of Spiral Delay Line," *QST*, Nov 1972, pp 13-15.
- M. A. Logan, "Coaxial-Cable Traps," Technical Correspondence, *QST*, Aug 1985, p 43.
- J. R. Mathison, "Inexpensive Traps for Wire Antennas," *QST*, Aug 1977, p 18.
- L. McCoy, "An Easy-to-Make Coax-Fed Multiband Trap Dipole," *QST*, Dec 1964.
- M. Mims, "The Mims Signal Squirter," *QST*, Dec 1939, p 12.
- G. E. O'Neil, "Trapping the Mysteries of Trapped Antennas," *Ham Radio*, Oct 1981, pp 10-16.
- E. W. Pappenfus, "The Conical Monopole Antenna," *QST*, Nov 1966, pp 21-24.
- L. Richard, "Parallel Dipoles of 300-Ohm Ribbon," *QST*, Mar 1957.
- R. R. Shellenback, "Try the 'TJ'," *QST*, Jun 1982, p 18.
- R. R. Shellenback, "The JF Array," *QST*, Nov 1982, p 26.
- H. Scholle and R. Steins, "Eine Doppel-Window Antenna fur Acht Bander," *cq-DL*, Sep 1983, p 427. (In English: *QST*, Aug 1990, pp 33-34.)
- M. Seybold, W2RYI, "The Low-Frequency Discone," *CQ*, July 1950, p 13.
- D. P. Shafer, "Four-Band Dipole with Traps," *QST*, Oct 1958.
- R. C. Sommer, "Optimizing Coaxial-Cable Traps," *QST*, Dec 1984, p 37.
- L. Varney, "The G5RV Multiband Antenna . . . Up-to-Date," *The ARRL Antenna Compendium, Vol 1* (Newington: ARRL, 1985), pp 86.
- L. G. Windom, "Notes on Ethereal Antennas," *QST*, Sep 1929, pp 19-22, 84.
- W. I. Orr, W6SAI, editor, "The Low-Frequency Discone," *RADIO Handbook*, 14th Edition (Editors and Engineers, 1956), p 369.



# Chapter 8

# Multielement Arrays

The gain and directivity offered by an array of elements represents a worthwhile improvement both in transmitting and receiving. Power gain in an antenna is the same as an equivalent increase in the transmitter power. But unlike increasing the power of one's own transmitter, antenna gain works equally well on signals received from the favored direction. In addition, the directivity reduces the strength of signals coming from the directions not favored, and so helps discriminate against interference.

One common method of obtaining gain and directivity is to combine the radiation from a group of  $\lambda/2$  dipoles to concentrate it in a desired direction. A few words of explanation may help make it clear how power gain is obtained.

In **Fig 1**, imagine that the four circles, A, B, C and D, represent four dipoles so far separated from each other that the coupling between them is negligible. Also imagine that point P is so far away from the dipoles that the distance from P to each one is exactly the same (obviously P would have to be much farther away than it is shown in this drawing). Under these conditions the fields from all the dipoles will add up at P if all four are fed RF currents in the same phase.

Let us say that a certain current, I, in dipole A will produce a certain value of field strength, E, at the distant point P. The same current in any of the other dipoles will produce the same field at P. Thus, if only dipoles A and B are operating, each with a current I, the field at P will be 2E.

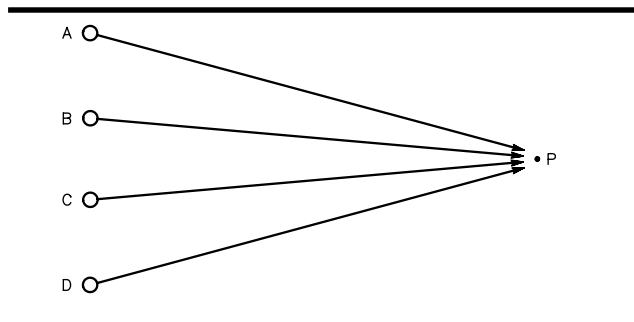
With A, B and C operating, the field will be 3E, and with all four operating with the same I, the field will be 4E. Since the power received at P is proportional to the square of the field strength, the relative power received at P is 1, 4, 9 or 16, depending on whether one, two, three or four dipoles are operating.

Now, since all four dipoles are alike and there is no coupling between them, the same power must be put into each in order to cause the current I to flow. For two dipoles the relative power input is 2, for three dipoles it is 3, for four dipoles 4, and so on. The actual gain in each case is the relative received (or output) power divided by the relative input power. Thus we have the results shown in **Table 1**. The power ratio is directly proportional to the number of elements used.

It is well to have clearly in mind the conditions under which this relationship is true:

- 1) The fields from the separate antenna elements must be in phase at the receiving point.
- 2) The elements are identical, with equal currents in all elements.
- 3) The elements must be separated in such a way that the current induced in one by another is negligible; that is, the radiation resistance of each element must be the same as it would be if the other elements were not there.

Very few antenna arrays meet all these conditions exactly. However, the power gain of a directive array using dipole elements with optimum values of element spacing is approximately proportional to the number of elements.



**Fig 1**—Fields from separate antennas combine at a distant point, P, to produce a field strength that exceeds the field produced by the same power in a single antenna.

**Table 1**  
**Comparison of Dipoles with Negligible Coupling**  
**(See Fig 1)**

Dipoles	Relative Output Power	Relative Input Power	Power Gain	Gain in dB
A only	1	1	1	0
A and B	4	2	2	3
A, B and C	9	3	3	4.8
A, B, C and D	16	4	4	6

Another way to say this is that a gain of approximately 3 dB will be obtained each time the number of elements is doubled, assuming the proper element spacing is maintained. It is possible, though, for an estimate based on this rule to be in error by a ratio factor of two or more (gain error of 3 dB or more), especially if mutual coupling is *not* negligible.

### DEFINITIONS

An *element* in a multi-element directive array is usually a  $\lambda/2$  radiator or a  $\lambda/4$  vertical element above ground. The length is not always an exact electrical half or quarter wavelength, because in some types of arrays it is desirable that the element show either inductive or capacitive reactance. However, the departure in length from resonance is ordinarily small (not more than 5% in the usual case) and so has no appreciable effect on the radiating properties of the element.

Antenna elements in multi-element arrays of the type considered in this chapter are always either *parallel*, as in Fig 2A, or *collinear* (end-to-end), as in Fig 2B. Fig 2C shows an array combining both parallel and collinear elements. The elements can be either horizontal or vertical, depending on whether horizontal or vertical polarization is desired. Except for space communications, there is seldom any reason for mixing polarization, so arrays are customarily constructed with all elements similarly polarized.

A *driven element* is one supplied power from the transmitter, usually through a transmission line. A *parasitic element* is one that obtains power solely through coupling to another element in the array because of its proximity to such an element.

A *driven array* is one in which all the elements are driven elements. A *parasitic array* is one in which one or more of the elements are parasitic elements. At least one element must be a driven element, since you must somehow introduce power into the array.

A *broadside array* is one in which the principal direction of radiation is perpendicular to the axis of the array and to the plane containing the elements, as shown in Fig 3. The elements of a broadside array may be collinear, as in Fig 3A, or parallel (two views in Fig 3B).

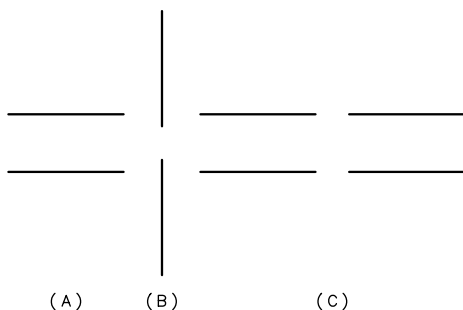


Fig 2—At A, parallel and at B, collinear antenna elements. The array shown at C combines both parallel and collinear elements.

An *end-fire array* is one in which the principal direction of radiation coincides with the direction of the array axis. This definition is illustrated in Fig 4. An end-fire array must consist of parallel elements. They cannot be collinear, as  $\lambda/2$  elements do not radiate straight off their ends. A Yagi is a familiar form of an end-fire array.

A *bidirectional array* is one that radiates equally well in either direction along the line of maximum radiation. A bidirectional pattern is shown in Fig 5A. A *unidirectional array* is one that has only one principal direction of radiation, as the pattern in Fig 5B shows.

The *major lobes* of the directive pattern are those in which the radiation is maximum. Lobes of lesser radiation intensity are called *minor lobes*. The *beamwidth* of a directive antenna is the width, in degrees, of the major lobe between the two directions at which the relative radiated power is equal to one half its value at the peak of the lobe. At these *half-power points* the field intensity is equal to 0.707 times its maximum value, or down 3 dB from the maximum. Fig 6 shows a lobe having a beamwidth of 30°.

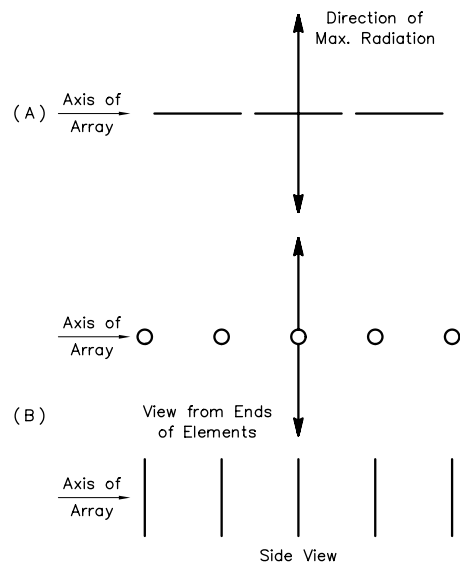


Fig 3—Representative broadside arrays. At A, collinear elements, with parallel elements at B.

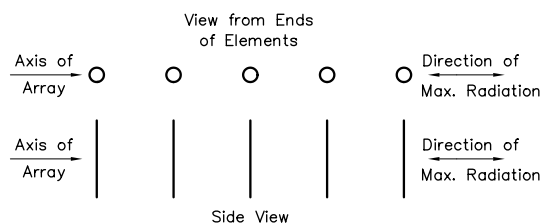


Fig 4—An end-fire array. Practical arrays may combine both broadside directivity (Fig 3) and end-fire directivity, including both parallel and collinear elements.

Unless specified otherwise, the term *gain* as used in this section is the power gain over an isotropic radiator in free space. The gain can also be compared with a  $\lambda/2$  dipole of the same orientation and height as the array under discussion, and having the same power input. Gain may either be measured experimentally or determined by calculation. Experimental measurement is difficult and often subject to considerable error, for two reasons. First, errors

normally occur in measurement because the accuracy of simple RF measuring equipment is relatively poor—even high-quality instruments suffer in accuracy compared with their low-frequency and dc counterparts. And second, the accuracy depends considerably on conditions—the antenna site, including height, terrain characteristics, and surroundings—under which the measurements are made. Calculations are frequently based on the measured or theoretical directive patterns of the antenna (see [Chapter 2](#)). The theoretical gain of an array may be determined approximately from:

$$G = 10 \log \frac{41,253}{\theta_H \theta_V} \quad (\text{Eq 1})$$

where

G = decibel gain over a dipole in its favored direction  
 $\theta_H$  = horizontal half-power beamwidth in degrees  
 $\theta_V$  = vertical half-power beamwidth in degrees.

This equation, strictly speaking, applies only to lossless antennas having approximately equal and narrow E- and H-plane beam widths—up to about  $20^\circ$ —and no large minor lobes. The E and H planes are discussed in [Chapter 2](#). The error may be considerable when the formula is applied to simple directive antennas having relatively large beam widths. The error is in the direction of making the calculated gain larger than the actual gain.

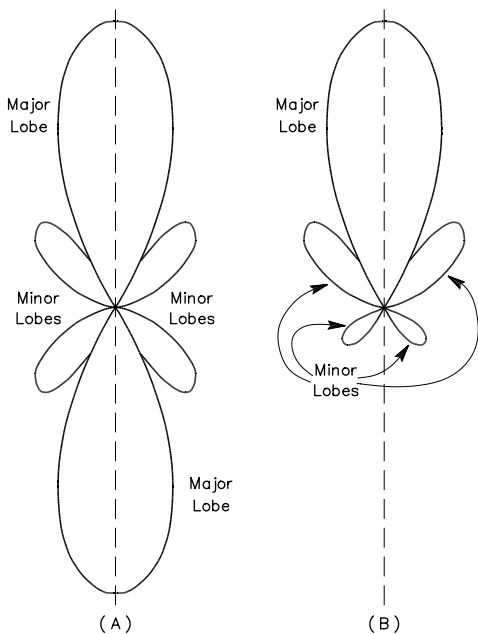
*Front-to-back ratio* (F/B) is the ratio of the power radiated in the favored direction to the power radiated in the opposite direction. See [Chapter 11](#) for a discussion of front-to-back ratio, and its close cousin, *worst-case front-to-rear ratio*.

## Phase

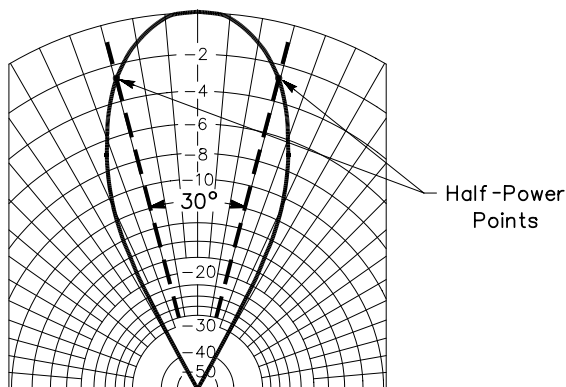
The term *phase* has the same meaning when used in connection with the currents flowing in antenna elements as it does in ordinary circuit work. For example, two currents are in phase when they reach their maximum values, flowing in the same direction, at the same instant. The direction of current flow depends on the way in which power is applied to the element.

This is illustrated in [Fig 7](#). Assume that by some means an identical voltage is applied to each of the elements at the ends marked A. Assume also that the coupling between the elements is negligible, and that the instantaneous polarity of the voltage is such that the current is flowing away from the point at which the voltage is applied. The arrows show the assumed current directions. Then the currents in elements 1 and 2 are in phase, since they are flowing in the same direction in space and are caused by the same voltage. However, the current in element 3 is flowing in the *opposite* direction in space because the voltage is applied to the opposite end of the element. The current in element 3 is therefore  $180^\circ$  out of phase with the currents in elements 1 and 2.

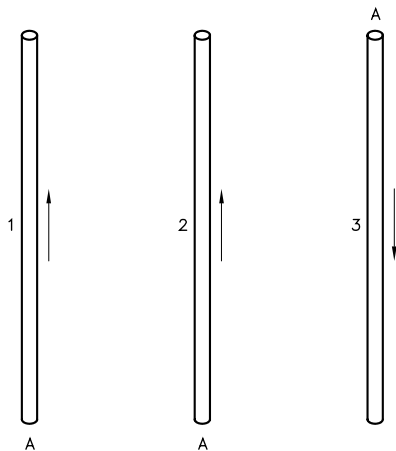
The phasing of driven elements depends on the direction of the element, the phase of the applied voltage,



**Fig 5—At A, typical bidirectional pattern and at B, unidirectional directive pattern. These drawings also illustrate the application of the terms *major* and *minor* to the pattern lobes.**



**Fig 6—The width of a beam is the angular distance between the directions at which the received or transmitted power is half the maximum power ( $-3$  dB). Each angular division of the pattern grid is  $5^\circ$ .**



**Fig 7—This drawing illustrates the phase of currents in antenna elements, represented by the arrows. The currents in elements 1 and 2 are in phase, while that in element 3 is 180° out of phase with 1 and 2.**

and the point at which the voltage is applied. In many systems used by amateurs, the voltages applied to the elements are exactly in or exactly out of phase with each other. Also, the axes of the elements are nearly always in the same direction, since parallel or collinear elements are invariably used. The currents in driven elements in such systems therefore are usually either exactly in or exactly out of phase with the currents in other elements.

It is possible to use phase differences of less than 180° in driven arrays. One important case is where the current in one set of elements differs by 90° from the current in another set. However, making provision for proper phasing in such systems is considerably more complex than in the case of simple 0° or 180° phasing, as described in a later section of this chapter.

In parasitic arrays the phase of the currents in the parasitic elements depends on the spacing and tuning, as described later.

### Ground Effects

The effect of the ground is the same with a directive antenna as it is with a simple dipole antenna. The reflection factors discussed in [Chapter 3](#) may therefore be applied to the vertical pattern of an array, subject to the same modifications mentioned in that chapter. In cases where the array elements are not all at the same height, the reflection factor for the mean height of the array may be used for a close approximation. The mean height is the average of the heights measured from the ground to the centers of the lowest and highest elements.

### MUTUAL IMPEDANCE

Consider two  $\lambda/2$  elements that are fairly close to each other. Assume that power is applied to only one element,

causing current to flow. This creates an electromagnetic field, which induces a voltage in the second element and causes current to flow in it as well. The current flowing in element 2 will in turn induce a voltage in element 1, causing additional current to flow there. The total current in 1 is then the sum (taking phase into account) of the original current and the induced current.

With element 2 present, the amplitude and phase of the resulting current in element 1 will be different than if element 2 were not there. This indicates that the presence of the second element has changed the impedance of the first. This effect is called *mutual coupling*. Mutual coupling results in a *mutual impedance* between the two elements. The mutual impedance has both resistive and reactive components. The actual impedance of an antenna element is the sum of its self-impedance (the impedance with no other antennas present) and its mutual impedances with all other antennas in the vicinity.

The magnitude and nature of the feed-point impedance of the first antenna depends on the amplitude of the current induced in it by the second, and on the phase relationship between the original and induced currents. The amplitude and phase of the induced current depend on the spacing between the antennas and whether or not the second antenna is tuned to resonance.

In the discussion of the several preceding paragraphs, power is applied to only one of the two elements. Do not interpret this to mean that mutual coupling exists only in parasitic arrays! It is important to remember that mutual coupling exists between any two conductors that are located near one another.

### Amplitude of Induced Current

The induced current will be largest when the two antennas are close together and are parallel. Under these conditions the voltage induced in the second antenna by the first, and in the first by the second, has its greatest value and causes the largest current flow. The coupling decreases as the parallel antennas are moved farther apart.

The coupling between collinear antennas is comparatively small, and so the mutual impedance between such antennas is likewise small. It is not negligible, however.

### Phase Relationships

When the separation between two antennas is an appreciable fraction of a wavelength, a measurable period of time elapses before the field from antenna 1 reaches antenna 2. There is a similar time lapse before the field set up by the current in number 2 gets back to induce a current in number 1. Hence the current induced in antenna 1 by antenna 2 will have a phase relationship with the original current in antenna 1 that depends on the spacing between the two antennas.

The induced current can range all the way from being completely in phase with the original current to being completely out of phase with it. If the currents are in phase,

the total current is larger than the original current, and the antenna feed-point impedance is reduced. If the currents are out of phase, the total current is smaller and the impedance is increased. At intermediate phase relationships the impedance will be lowered or raised depending on whether the induced current is mostly in or mostly out of phase with the original current.

Except in the special cases when the induced current is exactly in or out of phase with the original current, the induced current causes the phase of the total current to shift with respect to the applied voltage. Consequently, the presence of a second antenna nearby may cause the impedance of an antenna to be reactive—that is, the antenna will be detuned from resonance—even though its self-impedance is entirely resistive. The amount of detuning depends on the magnitude and phase of the induced current.

### Tuning Conditions

A third factor that affects the impedance of antenna 1 when antenna 2 is present is the tuning of number 2. If antenna 2 is not exactly resonant, the current that flows in it as a result of the induced voltage will either lead or lag the phase it would have if the antenna were resonant. This causes an additional phase advance or delay that affects the phase of the current induced back in antenna 1. Such a phase lag has an effect similar to a change in the spacing between self-resonant antennas. However, a change in tuning is not exactly equivalent to a change in spacing because the two methods do not have the same effect on the amplitude of the induced current.

### MUTUAL IMPEDANCE AND GAIN

The mutual coupling between antennas is important because it can have a significant effect on the amount of current that will flow for a given amount of power supplied. And it is the amount of *current* flowing that determines the field strength from the antenna. Other things being equal, if the mutual coupling between two antennas is such that the currents are greater for the same total power than would be the case if the two antennas were not coupled, the power gain will be greater than that shown in Table 1. On the other hand, if the mutual coupling is such as to reduce the current, the gain will be less than if the antennas were not coupled. The term *mutual coupling*, as used in this paragraph, assumes that the mutual impedance between elements is taken into account, along with the added effects of propagation delay because of element spacing, and element tuning or phasing.

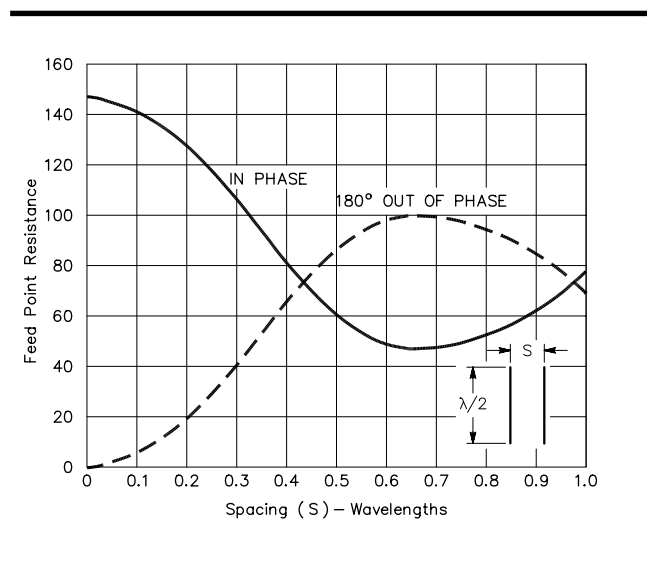
The calculation of mutual impedance between antennas is a complex problem. Data for two simple but important cases are graphed in Figs 8 and 9. These graphs do not show the mutual impedance, but instead show a more useful quantity—the feed-point resistance measured at the center of an antenna as it is affected by the spacing between two antennas.

As shown by the solid curve in Fig 8, the feed-point resistance at the center of either antenna, when the two are

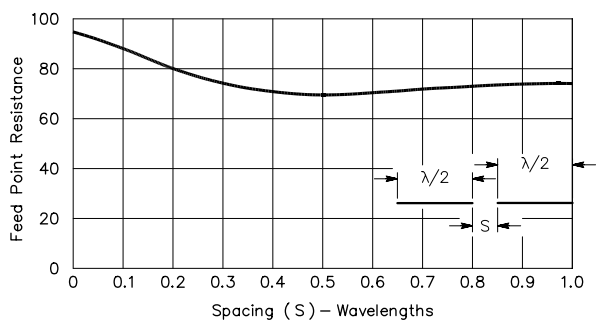
self-resonant, parallel, and operated in phase, decreases as the spacing between them is increased until the spacing is about  $0.7 \lambda$ . This is a broadside array. The maximum gain is achieved from a pair of such elements when the spacing is in this region, because the current is larger for the same power and the fields from the two arrive in phase at a distant point placed on a line perpendicular to the line joining the two antennas.

The dashed line in Fig 8, representing two antennas operated  $180^\circ$  out of phase (end-fire), cannot be interpreted quite so simply. The feed-point resistance decreases with spacing decreasing less than about  $0.6 \lambda$  in this case. However, for the range of spacings considered, only when the spacing is  $0.5 \lambda$  do the fields from the two antennas add up exactly in phase at a distant point in the favored direction. At smaller spacings the fields become increasingly out of phase, so the total field is less than the simple sum of the two. Smaller spacings thus decrease the gain at the same time that the reduction in feed point resistance is increasing it. For a lossless antenna, the gain goes through a maximum when the spacing is in the region of  $1/8 \lambda$ .

The feed-point resistance curve for two collinear elements in phase, Fig 9, shows that the feed-point resistance decreases and goes through a broad minimum in the region of  $0.4$  to  $0.6\lambda$  spacing between the adjacent ends of the antennas. As the minimum is not significantly less than the feed-point resistance of an isolated antenna, the gain will not exceed the gain calculated on the basis of uncoupled antennas. That is, the best that two collinear elements will give, even with optimum spacing, is a power gain of about 2 (3 dB). When the separation between the ends is very



**Fig 8—Feed-point resistance measured at the center of one element as a function of the spacing between two parallel  $1/2\text{-}\lambda$  self-resonant antenna elements. For ground-mounted  $1/4\text{-}\lambda$  vertical elements, divide these resistances by two.**



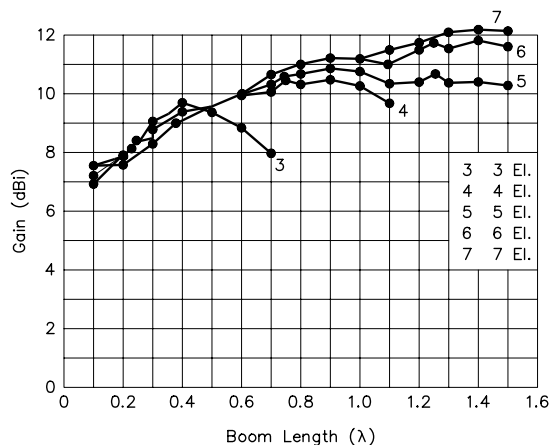
**Fig 9—Feed-point resistance measured at the center of one element as a function of the spacing between the ends of two collinear self-resonant  $\frac{1}{2}\lambda$ -antenna elements operated in phase.**

small—the usual method of operation—the gain is reduced.

### GAIN AND ARRAY DIMENSIONS

The gain of an array is principally determined by the dimensions of the array as long as there are a minimum number of elements. A good example of this is the relationship between boom length, gain and number of elements for an array such as a Yagi. **Fig 10** compares the gain versus boom length for Yagis with different numbers of elements. Notice that, for given number of elements, the gain increases as the boom length increases, up to a maximum. Beyond this point, longer boom lengths result in less gain for a given number of elements. This observation does not mean that it is always desirable to use only the minimum number of elements. Other considerations of array performance, such as front-to-back ratio, minor lobe amplitudes or operating bandwidth, may make it advantageous to use more than the minimum number of elements for a given array length. A specific example of this is presented in a later section in a comparison between a half-square, a bobtail curtain and a Bruce array.

In a broadside array the gain is a function of both the length and width of the array. The gain can be increased by adding more elements (with additional spacing) or by using longer elements ( $>\lambda/2$ ), although the use of longer elements requires proper attention to current phase in the elements. In general, in a broadside array the element spacing that



**Fig 10—Yagi gain for 3, 4, 5, 6 and 7-element beams as a function of boom length. (From *Yagi Antenna Design*, J. Lawson, W2PV.)**

gives maximum gain for a minimum number of elements, is in the range of 0.5 to 0.7  $\lambda$ . Broadside arrays with elements spaced for maximum gain will frequently have significant side lobes and associated narrowing of the main lobe beamwidth. Side lobes can be reduced by using more than the minimum number of elements, spaced closer than the maximum gain distance.

Additional gain can be obtained by expanding the array into a third dimension. An example of this is the stacking of endfire arrays in a broadside configuration. In the case of stacked short endfire arrays, maximum gain occurs with spacings in the region of 0.5 to 0.7  $\lambda$ . However, for longer higher-gain end-fire arrays, larger spacing is required to achieve maximum gain. This is important in VHF and UHF arrays, which often use long-boom Yagis.

### PARASITIC ARRAYS

The foregoing applies to multi-element arrays of both types, driven and parasitic. However, there are special considerations for driven arrays that do not necessarily apply to parasitic arrays, and vice versa. Such considerations for Yagi and quad parasitic arrays are presented in Chapters 11 and 12. The remainder of this chapter is devoted to driven arrays.

## Driven Arrays

Driven arrays in general are either broadside or end-fire, and may consist of collinear elements, parallel elements, or a combination of both. From a practical standpoint, the maximum number of usable elements depends on the frequency and the space available for the antenna. Fairly elaborate arrays, using as many as 16 or even 32 elements, can be installed in a rather small space when the operating

frequency is in the VHF range, and more at UHF. At lower frequencies the construction of antennas with a large number of elements is impractical for most amateurs.

Of course the simplest of driven arrays is one with just two elements. If the elements are collinear, they are always fed in phase. The effects of mutual coupling are not great, as illustrated in Fig 9. Therefore, feeding power to each

element in the presence of the other presents no significant problems. This may not be the case when the elements are parallel to each other. However, because the combination of spacing and phasing arrangements for parallel elements is infinite, the number of possible radiation patterns is endless. This is illustrated in Fig 11. When the elements are fed in phase, a broadside pattern always results. At spacings of less than  $\frac{5}{8} \lambda$  with the elements fed  $180^\circ$  out of phase, an end-fire pattern always results. With intermediate amounts of phase difference, the results cannot be so simply stated. Patterns evolve that are not symmetrical in all four quadrants.

Because of the effects of mutual coupling between the two driven elements, for a given power input greater or lesser currents will flow in each element with changes in spacing and phasing, as described earlier. This, in turn, affects the gain of the array in a way that cannot be shown merely by plotting the *shapes* of the patterns, as has been done in Fig 11. Therefore, supplemental gain information is also shown in Fig 11, adjacent to the pattern plot for each combination of spacing and phasing. The gain figures shown are referenced to a single element. For example, a pair of elements fed  $90^\circ$  apart at a spacing of  $\frac{1}{4} \lambda$  will have a gain in the direction of maximum radiation of 3.1 dB over a single element.

### Current Distribution in Phased Arrays

In the plots of Fig 11, the two elements are assumed to be identical and self-resonant. In addition, currents of equal amplitude are assumed to be flowing at the feed point of each element, a condition that most often will not exist in practice without devoting special consideration to the feeder system. Such considerations are discussed in the next section of this chapter.

Most literature for radio amateurs concerning phased arrays is based on the assumption that if all elements in the array are identical, the *current distribution* in all the elements will be identical. This distribution is presumed to be that of a single, isolated element, or nearly sinusoidal. However, information published in the professional literature as early as the 1940s indicates the existence of dissimilar current distributions among the elements of phased arrays. (See [Harrison and King](#) references in the Bibliography.) [Lewallen](#), in July 1990 *QST*, points out the causes and effects of dissimilar current distributions.

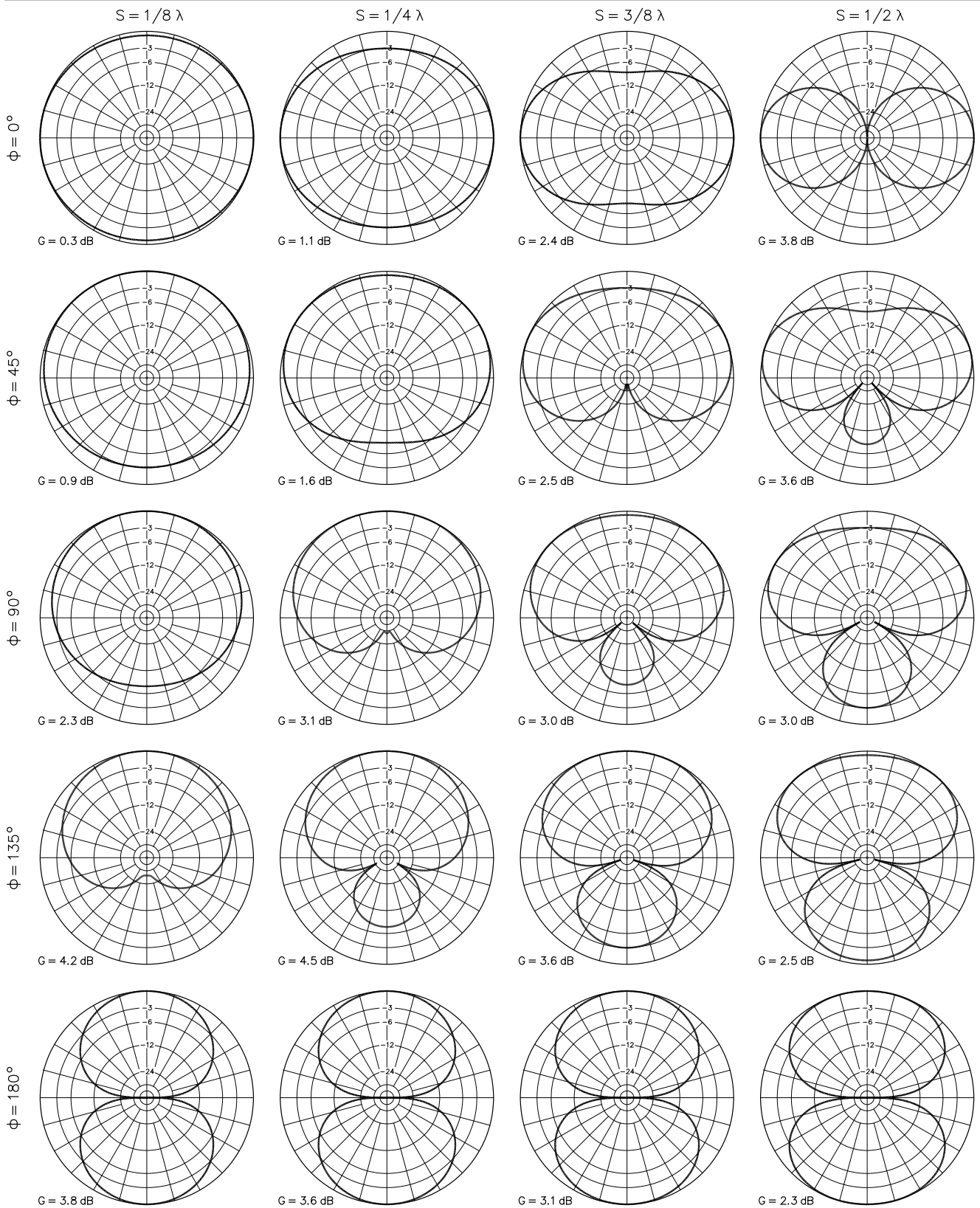
In essence, even though the two elements in a phased array may be identical and have exactly equal currents of the desired phase flowing *at the feed point*, the amplitude

and phase relationships degenerate with departure from the feed point. This happens any time the phase relationship is not  $0^\circ$  or  $180^\circ$ . Thus, the field strengths produced at a distant point by the individual elements may differ. This is because the field from each element is determined by the *distribution* of the current, as well as its magnitude and phase. The effects are minimal with shortened elements—verticals less than  $\frac{1}{4} \lambda$  or dipoles less than  $\frac{1}{2} \lambda$  long. The effects on radiation patterns begin to show at the above resonant lengths, and become profound with longer elements— $\frac{1}{2} \lambda$  or longer verticals and  $1 \lambda$  or longer center-fed elements. These effects are less pronounced with thin elements. The amplitude and phase degeneration takes place because the currents in the array elements are not sinusoidal. Even in two-element arrays with phasing of  $0^\circ$  or  $180^\circ$ , the currents are not sinusoidal, but in these two special cases they do remain identical.

The pattern plots of Fig 11 take element current distributions into account. The visible results of dissimilar distributions are incomplete nulls in some patterns, and the development of very small minor lobes in others. For example, the pattern for a phased array with  $90^\circ$  spacing and  $90^\circ$  phasing has traditionally been published in amateur literature as a cardioid with a perfect null in the rear direction. Fig 11, calculated for 7.15-MHz self-resonant dipoles of #12 wire in free space, shows a minor lobe at the rear and only a 33-dB front-to-back ratio.

It is characteristic of broadside arrays that the power gain is proportional to the length of the array but is substantially independent of the number of elements used, provided the optimum element spacing is not exceeded. This means, for example, that a five-element array and a six-element array will have the same gain, provided the elements in both are spaced so the overall array length is the same. Although this principle is seldom used for the purpose of reducing the number of elements because of complications introduced in feeding power to each element in the proper phase, it does illustrate the fact that there is nothing to be gained, in terms of more gain, by increasing the number of elements if the space occupied by the antenna is not increased proportionally.

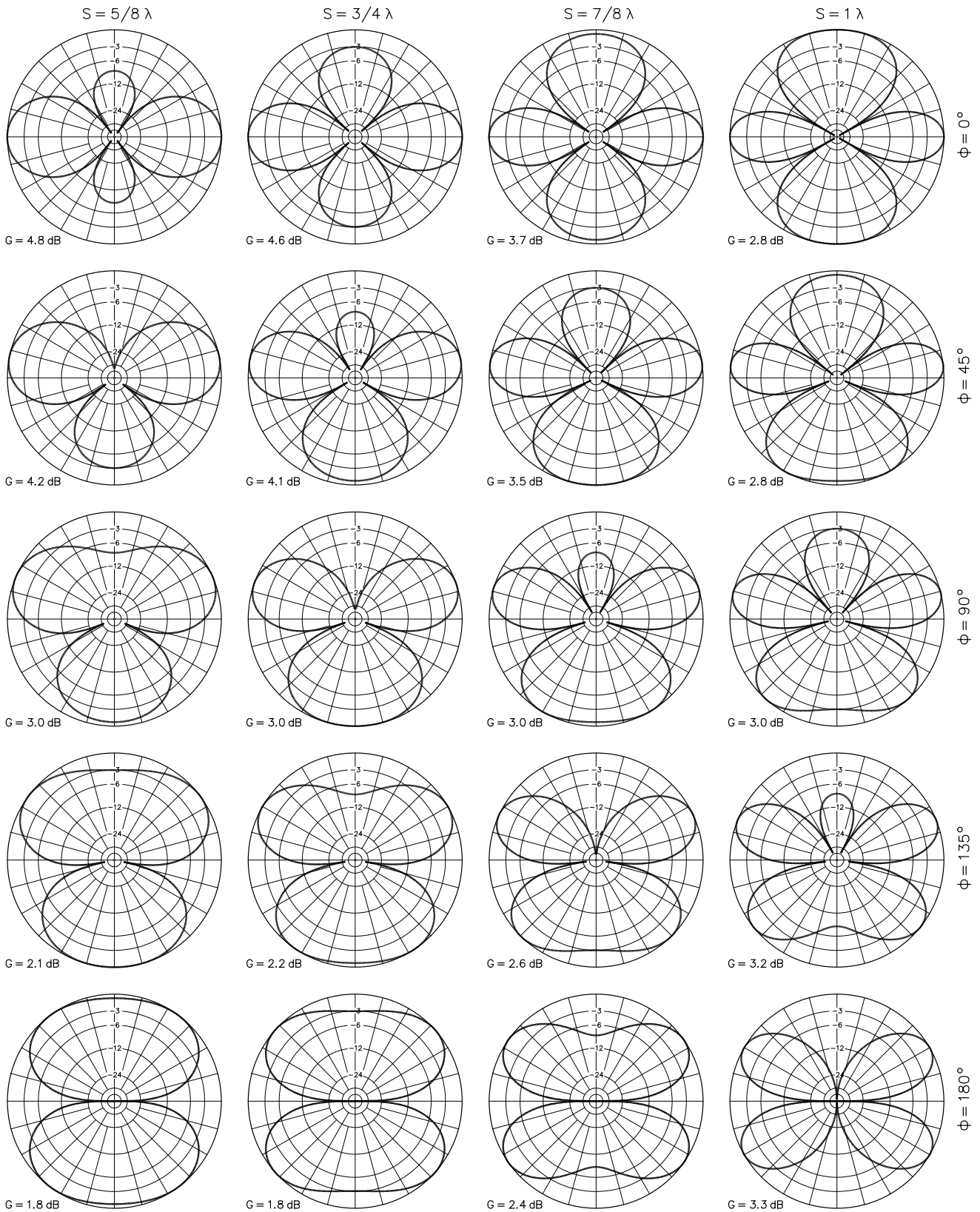
Generally speaking, the maximum gain in the smallest linear dimensions will result when the antenna combines both broadside and end-fire directivity and uses both parallel and collinear elements. In this way the antenna is spread over a greater volume of space, which has the same effect as extending its length to a much greater extent in one linear direction.



**Fig 11—H-plane patterns of two identical parallel driven elements, spaced and phased as indicated ( $S = \text{spacing}$ ,  $\phi = \text{phasing}$ ). The elements are aligned with the vertical ( $0^\circ$ - $180^\circ$ ) axis, and the element nearer the  $0^\circ$  direction (top of page) is of lagging phase at**

**angles other than  $0^\circ$ . The two elements are assumed to be thin and self-resonant, with equal-amplitude currents flowing at the feed point. See text regarding current distributions. The gain figure associated with each pattern indicates that of the array over a single**





element. The plots represent the horizontal or azimuth pattern at a  $0^\circ$  elevation angle of two  $1/4\text{-}\lambda$  vertical elements over a perfect conductor, or the free-space vertical or elevation pattern of two horizontal  $1/2\text{-}\lambda$  elements when viewed on end, with one element above

the other. (Patterns computed with *ELNEC*—see [Bibliography](#).)

# Phased Array Techniques

Phased antenna arrays have become increasingly popular for amateur use, particularly on the lower frequency bands, where they provide one of the few practical methods of obtaining substantial gain and directivity. This section on phased array techniques was written by Roy W. Lewallen, W7EL. The operation and limitations of phased arrays, how to design feed systems to make them work properly, and how to make necessary tests and adjustments are discussed in the pages that follow. The examples deal primarily with vertical HF arrays, but the principles apply to horizontal and VHF/UHF arrays as well.

The performance of a phased array is determined by several factors. Most significant among these are the characteristics of a single element, reinforcement or cancellation of the fields from the elements, and the effects of mutual coupling. To understand the operation of phased arrays, it is first necessary to understand the operation of a single antenna element.

## Fundamentals of Phased Arrays

Of primary importance is the strength of the field produced by the element. The field radiated from a linear (straight) element, such as a dipole or vertical monopole, is proportional to the sum of the elementary currents flowing in each part of the antenna element. For this discussion it is important to understand what determines the current in a single element.

The amount of current flowing at the base of a resonant ground mounted vertical or ground-plane antenna is given by the familiar formula

$$I = \sqrt{\frac{P}{R}} \quad (\text{Eq 2})$$

where

- P is the power supplied to the antenna
- R is the feed-point resistance.

R consists of two parts, the loss resistance and the radiation resistance. The loss resistance,  $R_L$ , includes losses in the conductor, in the matching and loading components, and dominantly (in the case of ground-mounted verticals), in ground losses. The power *dissipated* in the radiation resistance,  $R_R$ , is the power that is radiated, so maximizing the power dissipated by the radiation resistance is desirable. However, the power dissipated in the loss resistance truly is lost (as heat), so resistive losses should be made as small as possible.

The radiation resistance of an element may be derived from electromagnetic field theory, being a function of antenna length, diameter, and geometry. Graphs of radiation resistance versus antenna length are given in [Chapter 2](#). The radiation resistance of a thin  $1/4$ - $\lambda$  ground-mounted vertical is about 36  $\Omega$ . A  $1/2$ - $\lambda$  dipole in free space has a radiation resistance of about 73  $\Omega$ . Reducing the antenna lengths by

one half drops the radiation resistances to approximately 7 and 14  $\Omega$ , respectively.

## Radiation Efficiency

To generate a stronger field from a given radiator, it is necessary either to increase the power P (the brute-force solution), or to decrease the loss resistance  $R_L$  (by putting in a more elaborate ground system for a vertical, for instance), or to somehow decrease the radiation resistance  $R_R$  so more current will flow with a given power input. This can be seen by expanding the formula for base current as:

$$I = \sqrt{\frac{P}{R_R + R_L}} \quad (\text{Eq 3})$$

Splitting the feed-point resistance into components  $R_R$  and  $R_L$  easily leads to an understanding of element efficiency. The efficiency of an element is the proportion of the total power that is actually radiated. The roles of  $R_R$  and  $R_L$  in determining efficiency can be seen by analyzing a simple equivalent circuit, shown in [Fig 12](#).

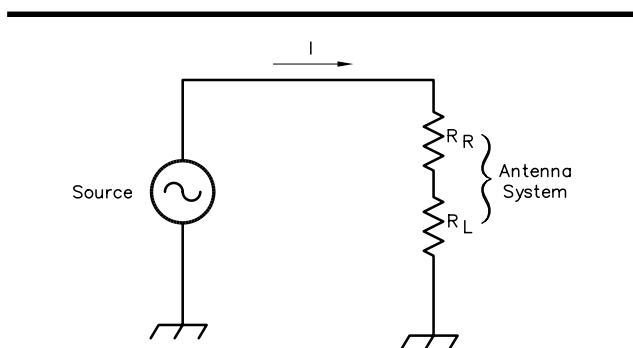
The power dissipated in  $R_R$  (the radiated power) equals  $I^2 R_R$ . The total power supplied to the antenna system is

$$P = I^2 (R_R + R_L) \quad (\text{Eq 4})$$

so the efficiency (the fraction of supplied power that is actually radiated) is

$$\text{Eff} = \frac{I^2 R_R}{I^2 (R_R + R_L)} = \frac{R_R}{R_R + R_L} \quad (\text{Eq 5})$$

Efficiency is frequently expressed in percent, but expressing it in decibels relative to a 100%-efficient radiator gives a better idea of what to expect in the way of signal strength. The field strength of an element relative to a lossless but otherwise identical element, in dB, is



**Fig 12—Simplified equivalent circuit for a single-element resonant antenna.  $R_R$  represents the radiation resistance, and  $R_L$  the ohmic losses in the total antenna system.**

$$\text{FSG} = 10 \log \frac{R_R}{R_R + R_L} \quad (\text{Eq 6})$$

where FSG = field strength gain, dB.

For example, information presented by [Sevick](#) in March 1973 *QST* shows that a  $1/4\text{-}\lambda$  ground-mounted vertical antenna with four  $0.2\text{-}\lambda$  radials has a feed-point resistance of about  $65 \Omega$  (see the Bibliography at the end of this chapter). The efficiency of such a system is  $36/65 = 55.4\%$ . It is rather disheartening to think that, of 100 W fed to the antenna, only 55 W are being radiated, with the remainder literally warming up the ground. Yet the signal will be only  $10 \log (36/65) = -2.57 \text{ dB}$  relative to the same vertical with a perfect ground system. In view of this information, trading a small reduction in signal strength for lower cost and greater simplicity may become an attractive consideration.

So far, only the current at the base of a resonant antenna has been discussed, but the field is proportional to the sum of currents in each tiny part of the antenna. The field is a function of not only the magnitude of current flowing at the base, but also the distribution of current along the radiator and the length of the radiator. However, nothing can be done at the base of the antenna to change the current distribution, so for a given element, the field strength is proportional to the base current (or center current, in the case of a dipole). However, changing the radiator length or loading it at some point other than the feed point will change the current distribution. More information on shortened or loaded radiators may be found in Chapters 2 and 6, and in the Bibliography references of this chapter. A few other important facts follow.

- 1) If there is no loss, the field from even an infinitesimally short radiator is less than  $1/2 \text{ dB}$  weaker than the field from a half-wave dipole or quarter-wave vertical. Without loss, all the supplied power is radiated regardless of the antenna length, so the only factor influencing gain is the slight difference in the patterns of very short and  $1/2\text{-}\lambda$  antennas. The small pattern difference arises from different current distributions. A short antenna has a very low radiation resistance, resulting in a heavy current flow over its short length. In the absence of loss, this generates a field strength comparable to that of a longer antenna. Where loss is present—that is, in practical antennas—shorter radiators usually don't do so well, since the low radiation resistance leads to lower efficiency for a given loss resistance. If care is taken, short antennas can achieve good efficiency.
- 2) The feed-point resistance of folded antennas isn't the radiation resistance as the term is used here. The act of folding an antenna only transforms the input impedance to a higher value, providing an easier match in some cases. The higher feed-point impedance doesn't help the efficiency, since the resulting smaller currents flow through more conductors, for the same net loss. In a folded vertical, the same total current ends up flowing through the ground system, again resulting in the same loss.
- 3) The current flowing in an element with a given power

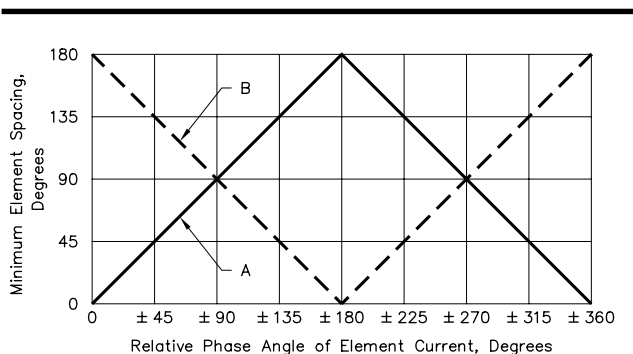
input can be increased, or decreased, by mutual coupling to other elements. The effect is equivalent to changing the element radiation resistance. Mutual coupling is sometimes regarded as a *minor* effect, but most often it is not minor!

### Field Reinforcement and Cancellation

Consider two elements that each produce a field strength of, say, exactly 1 millivolt per meter (mV/m) at some distance many wavelengths from the array. In the direction in which the fields are in phase, a total field of 2 mV/m results; in the direction in which they are out of phase, a zero field results. The ratio of maximum to minimum field strength of this array is  $2/0$ , or infinite.

Now suppose, instead, that one field is 10% high and the other 10% low—1.1 and 0.9 mV/m, respectively. In the forward direction, the field strength is still 2 mV/m, but in the canceling direction, the field will be 0.2 mV/m. The front-to-back ratio has dropped from infinite to  $2/0.2$ , or 20 dB. (Actually, slightly more power is required to redistribute the field strengths this way, so the forward gain is reduced—but only by a small amount, less than 0.1 dB.) For most arrays, unequal fields from the elements have a minor effect on forward gain, but a major effect on pattern nulls.

Even with perfect current balance, deep nulls aren't assured. **Fig 13** shows the minimum spacing required for total field reinforcement or cancellation. If the element spacing isn't adequate, there may not be any direction in which the fields are completely out of phase (see curve B of Fig 13). Slight physical and environmental differences between elements will invariably affect null depths, and null depths will vary with elevation angle. However, a properly designed and fed array can, in practice, produce very impressive nulls. The key to achieving good performance is being able to control the fields from the elements. This, in turn, requires knowing how to control the currents in the



**Fig 13—Minimum element spacing required for total field reinforcement, curve A, or total field cancellation, curve B. Total cancellation results in pattern nulls in one or more directions. Total reinforcement does not necessarily mean there is gain over a single element, as the effects of loss and mutual coupling must also be considered.**

elements, since the fields are proportional to the currents. Most phased arrays require the element currents to be equal in magnitude and different in phase by some specific amount. Just how this can be accomplished is explained in a subsequent section.

## MUTUAL COUPLING

Mutual coupling refers to the effects which the elements in an array have on each other. Mutual coupling can occur intentionally or entirely unintentionally. For example, Lewallen has observed effects such as a quad coupling to an inverted-V dipole to form a single, very strange, antenna system. The current in the “parasitic element” (non-driven antenna) was caused entirely by mutual coupling, just as in the familiar Yagi antenna. The effects of mutual coupling are present regardless of whether or not the elements are driven.

Suppose that two driven elements are very far from each other. Each has some voltage and current at its feed point. For each element, the ratio of this voltage to current is the element self-impedance. If the elements are brought close to each other, the current in each element will change in amplitude and phase because of coupling with the field from the other element. Significant mutual coupling occurs at spacings as great as a wavelength or more. The fields change the currents, which change the fields. There is an equilibrium condition where the currents in all elements (hence, their fields) are totally interdependent. The feed-point impedances of all elements also are changed from their values when far apart, and all are dependent on each other. In a driven array, the changes in feed-point impedances can cause additional changes in element currents, because the operation of many feed systems depends on the element feed-point impedances.

Connecting the elements to a feed system to form a driven array does not eliminate the effects of mutual coupling. In fact, in many driven arrays the mutual coupling has a greater effect on antenna operation than the feed system does. All feed-system designs must account for the impedance changes caused by mutual coupling if the desired current balance and phasing are to be achieved.

Several general statements can be made regarding phased-array systems. Mutual coupling accounts for these characteristics.

- 1) The resistances and reactances of all elements of an array generally will change substantially from the values of an isolated element.
- 2) If the elements of a two-element array are identical and have equal currents, which are in phase or 180° out of phase, the feed-point impedances of the two elements will be equal. But they will be different than for an isolated element. If the two elements are part of a larger array, their impedances can be very different from each other.
- 3) If the elements of a two-element array have currents that are neither in phase (0°) nor out of phase (180°), their feed-point impedances will not be equal. The difference will be substantial in typical amateur arrays.

- 4) The feed-point resistances of the elements in a closely spaced, 180° out-of-phase array will be very low, resulting in poor efficiency unless care is taken to minimize loss. This is also true for any other closely spaced array with significant predicted gain.

## Gain

Gain is strictly a relative measure, so the term is completely meaningless unless accompanied by a statement of just what it is relative to. One useful measure for phased array gain is *gain relative to a single similar element*. This is the increase in signal strength that would be obtained by replacing a single element by an array made from elements just like it. All gain figures in this section are relative to a single similar element unless otherwise noted. In some instances, such as investigating what happens to array performance when *all* elements become more lossy, gain refers to a more absolute, although unattainable standard; a lossless element. Uses of this standard are explicitly noted.

Why does a phased array have gain? One way to view it is in terms of directivity. Since a given amount of radiated power, whether radiated from one or a dozen elements, must be radiated *somewhere*, field strength must be increased in some directions if it is reduced in others. There is no guarantee that the fields from the elements of an arbitrary array will completely reinforce or cancel in any direction; element spacing must be adequate for either to happen (see Fig 13). If the fields reinforce or cancel to only a single extent, causing a pattern similar to that of a single element, the gain will also be similar to that of a single element.

To get a feel for how much gain a phased array can deliver, consider what would happen if there were no change in element feed-point resistance from mutual coupling. This actually does occur at some spacings and phasings, but not in commonly used systems. It is a useful example, nevertheless.

In the fictitious array the elements are identical and there are no resistance changes from mutual coupling. The feed-point resistance,  $R_F$ , equals  $R_R + R_L$ , the sum of radiation and loss resistances. If power  $P$  is put into a single element, the feed-point current is

$$I_F = \sqrt{\frac{P}{R_F}} \quad (\text{Eq 7})$$

At a given distance, the field strength is proportional to the current, so the field strength is

$$E = kI_F = k\sqrt{\frac{P}{R_F}} \quad (\text{Eq 8})$$

where  $k$  is the constant relating the element current to the field strength at the chosen distance.

If, instead, the power is equally split between two elements,

$$I_{F1} = I_{F2} = \sqrt{\frac{P/2}{R_F}} \quad (\text{Eq 9})$$

From this,

$$E_1 = E_2 = k \sqrt{\frac{P/2}{R_F}} \quad (\text{Eq 10})$$

If the elements are spaced far enough apart to allow full field reinforcement, the total field in the favored direction will be

$$E_1 = E_2 = 2k \sqrt{\frac{P/2}{R_F}} = \sqrt{2} k \sqrt{\frac{P}{R_F}} \quad (\text{Eq 11})$$

This represents a field strength gain of

$$\text{FSG} = 20 \log \sqrt{2} = 3 \text{ dB} \quad (\text{Eq 12})$$

where FSG = field strength gain, dB.

The power gain in dB equals the field strength gain in dB. The above argument leading to Eq 11 can be extended to show that the gain in dB for an array of  $n$  elements, without resistance changes from mutual coupling and with sufficient spacing and geometry for total field reinforcement, is

$$\text{FSG} = 20 \log \sqrt{n} = 10 \log n \quad (\text{Eq 13})$$

That is, a five-element array satisfying these assumptions would have a power gain of 5 times, or about 7 dB. Remember, the assumption was made that equal power is fed to each element. With equal element resistances and no resistance changes from mutual coupling, *equal currents* are therefore made to flow in all elements.

The gain of an array can be increased or decreased from  $10 \log n$  decibels by mutual coupling, but any loss will move the gain back toward  $10 \log n$ . This is because resistance changes from mutual coupling get increasingly swamped by the loss as the loss increases. Arrays designed to have substantially more gain than  $10 \log n$  decibels require heavy element currents. As designed gain increases, the required currents increase dramatically, resulting in power losses that partially or totally negate the expected gain. The net result is a practical limit of about  $10 \log n$  for the gain in dB of an  $n$ -element array, and this gain can be achieved only if extreme attention is paid to keeping losses very small. The majority of practical arrays, particularly arrays of ground-mounted verticals, have gains closer to  $10 \log n$  decibels.

The foregoing comments indicate that many of the claims about the gain of various arrays are exaggerated, if not ridiculous. But an honest 3 dB or so of gain from a two-element array can really be appreciated if an equally honest 3 dB has been attempted by other means. Equations for calculating array gain and examples of their use are given in a later section of this chapter.

### FEEDING PHASED ARRAYS

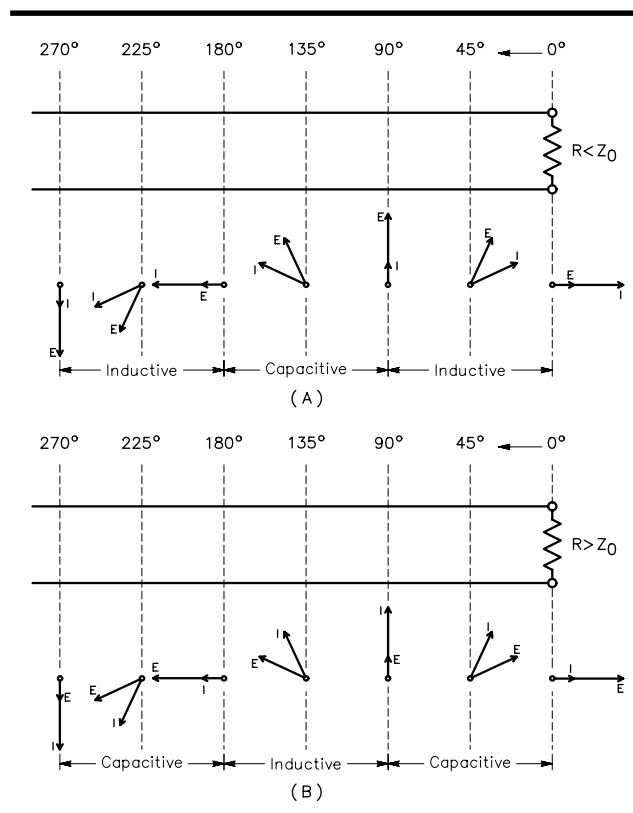
The previous section explains why the currents in the elements must be very close to the ratios required by the array design. This section explains how to feed phased arrays to produce the desired current ratio and phasing. Since the desired current ratio is 1:1 for virtually all two-element and for most

larger amateur arrays, special attention is paid to methods of assuring equal element currents. Other current ratios are also examined.

### Phasing Errors

For an array to produce the desired pattern, the element currents must have the required magnitude and the required phase relationship. On the surface, this sounds easy; just make sure that the difference in electrical lengths of the feed lines to the elements equals the desired phase angle. Unfortunately, this approach doesn't necessarily achieve the desired result. The first problem is that the phase shift through the line is not equal to its electrical length. The current (or, for that matter, voltage) delay in a transmission line is equal to its electrical length in only a few special cases—cases which do not exist in most amateur arrays! The impedance of an element in an array is frequently very different from the impedance of an isolated element, and the impedances of all the elements in an array can be different from each other.

Consequently, the elements seldom provide a matched load for the element feed lines. The effect of mismatch on phase shift can be seen in **Fig 14**. Observe what happens to the phase of the current and voltage on a line terminated by a purely resistive impedance which is lower than the characteristic impedance of the line (Fig 14A). At a point  $45^\circ$  from the load, the current has advanced less than  $45^\circ$ ,



**Fig 14—Resultant voltages and currents along a mismatched line. At A,  $R$  less than  $Z_0$ , and at B,  $R$  greater than  $Z_0$ .**

and the voltage more than  $45^\circ$ . At  $90^\circ$  from the load, both are advanced  $90^\circ$ . At  $135^\circ$ , the current has advanced more and the voltage less than  $135^\circ$ . This apparent slowing down and speeding up of the current and voltage waves is caused by interference between the forward and reflected waves. It occurs on any line not terminated with a pure resistance equal to its characteristic impedance. If the load resistance is greater than the characteristic impedance of the line, as shown in Fig 14B, the voltage and current exchange angles. Adding reactance to the load causes additional phase shift. The *only* cases in which the current (or voltage) delay is equal to the electrical length of the line are

- 1) When the line is *flat*, that is, terminated in a purely resistive load equal to its characteristic impedance;
- 2) When the line length is an integral number of half wavelengths;
- 3) When the line length is an odd number of quarter wavelengths *and* the load is purely resistive; and
- 4) When other specific lengths are used for specific load impedances.

Just how much phase error can be expected if two lines are simply hooked up to form an array? There is no simple answer. Some casually designed feed systems might deliver satisfactory results, but most will not. Later examples show just what the consequences of casual feeding can be.

The effect of phasing errors is to alter the basic shape of the radiation pattern. Nulls may be reduced in depth, and additional lobes added. Actual patterns can be calculated by using Eq 15 in a later section of this chapter. The effects of phasing errors on the shape of a  $90^\circ$  fed,  $90^\circ$  spaced array pattern are shown in Fig 15.

A second problem with simply connecting feed lines of different lengths to the elements is that the lines will change the *magnitudes* of the currents. The magnitude of

the current (or voltage) out of a line does not equal the magnitude in, except in cases 1, 2 and 4 above. The feed systems presented here assure currents which are correct in both magnitude and phase.

### The Wilkinson Divider

The *Wilkinson divider*, sometimes called the *Wilkinson power divider*, has been promoted in recent years as a means to distribute power among the elements of a phased array. It is therefore worthwhile to investigate just what the Wilkinson divider does.

The Wilkinson divider is shown in Fig 16. It is a very useful device for *splitting power* among several loads, or, in reverse, combining the outputs from several generators. If all loads are equal to the design value (usually  $50\ \Omega$ ), the power from the source is split equally among them, and no power is dissipated in the resistors. If the impedance of one of the loads should change, however, the power which was being delivered to that load becomes shared between it and the resistors. The power to the other loads is unchanged, so they are not affected by the errant load.

The network is also commonly used to combine the outputs of several transmitters to obtain a higher power than a single transmitter can deliver. The great value of the network becomes evident by observing what happens if one transmitter fails. The other transmitters continue working normally, delivering their full power to the load. The Wilkinson network prevents them, or the load, from *seeing* the failed transmitter, except as a reduction of total output power. Most other combining techniques would result in incorrect operation or failure of the remaining transmitters.

The Wilkinson divider is a port-to-port isolation device. It does *not* assure equal powers or currents in all loads. When connected to a phased array, it might make the system more

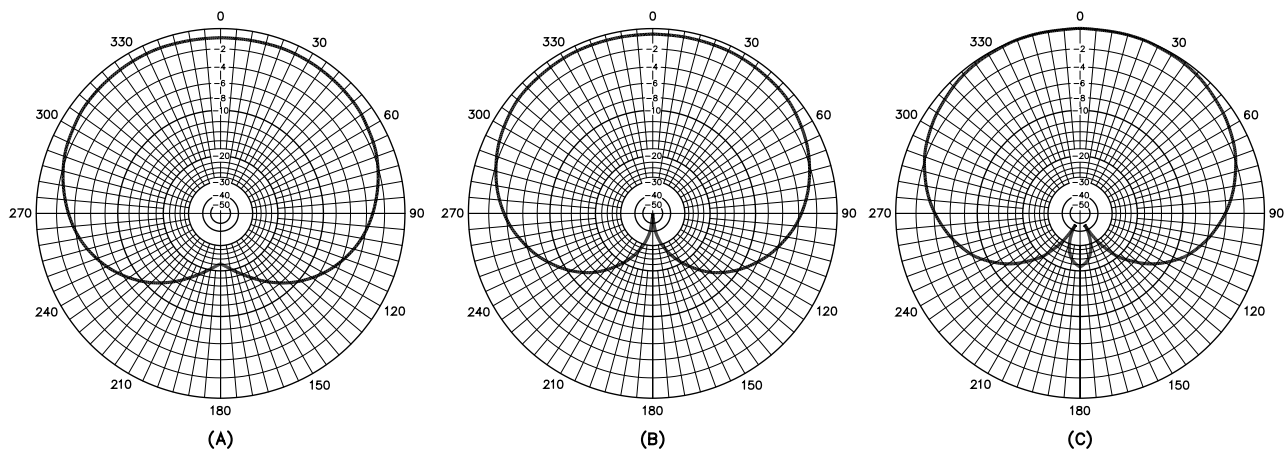
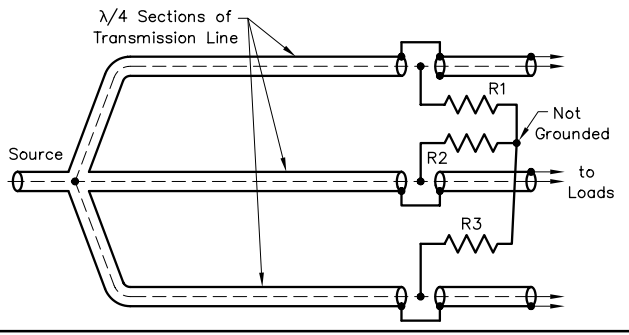


Fig 15—The change in pattern of a  $90^\circ$  spaced array caused by deviations from  $90^\circ$  phasing (equal currents and similar current distributions assumed). At A, B and C the respective phase angles are  $80^\circ$ ,  $90^\circ$  and  $100^\circ$ . Note the minor changes in gain as well as in pattern shapes with phase angle deviations. Gain is referenced to a single element; add 3.4 dB to the scale values shown for each plot.



**Fig 16—The Wilkinson divider. Three output ports are shown here, but the number may be reduced to two or increased as necessary. If (and only if) the source and all load impedances equal the design impedance, the power from the source will be split equally among the loads. The  $Z_0$  of the  $\lambda/4$ -sections is equal to the load impedance times the square root of the number of loads. R1, R2, R3—Noninductive resistors having a value equal to the impedance of the loads.**

broadband—by an amount directly related to the amount of power being lost in the resistors! Amateurs feeding a *four-square* array (reference Atchley, Steinhelfer and White—see Bibliography) with this network have reported one or more resistors getting very warm, indicating lost power that would be used to advantage if radiated.

Incidentally, if the divider is to be used for its intended purpose, the source impedance must be correct for proper operation. Hayward and DeMaw have pointed out that amateur transmitters do not necessarily have a well-defined output impedance (see Bibliography).

In summary, if the Wilkinson divider is used for feeding a phased array, (1) it will *not* assure equal element powers (which are not wanted anyway). (2) It will *not* assure equal element currents (which *are* wanted). (3) It will waste power. The Wilkinson divider is an extremely useful device. But it is not what is needed for feeding phased antenna arrays.

### The Broadcast Approach

Networks can be designed to transform the element base impedances to, say, 50 Ω resistive. Then another network can be inserted at the junction of the feed lines to properly divide the power among the elements (not necessarily equally!). And finally, additional networks must be built to correct for the phase shifts of the other networks. This general approach is used by the broadcast industry. Although this technique can be used to feed any type of array, design is difficult and adjustment is tedious, as all adjustments interact. When the relative currents and phasings are adjusted, the feed-point impedances change, which in turn affect the element currents and phasings, and so on. A further disadvantage of using this method is that switching the array direction is generally impossible. Information on applying this technique to amateur arrays may be found in Paul Lee’s book.

### A PREFERRED FEED METHOD

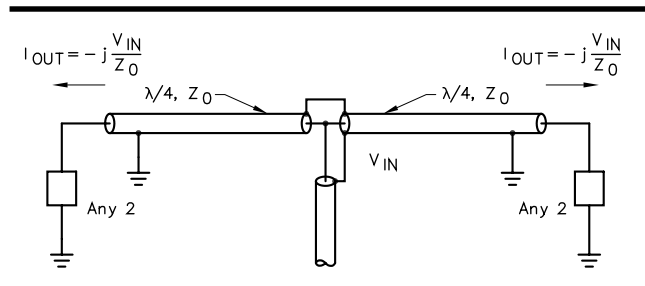
The feed method introduced here has been used in its simplest form to feed television receiving antennas and other arrays, as presented by Jasik, pages 2-12 and 24-10. However, this feed method has not been widely applied to amateur arrays.

The method takes advantage of an interesting property of  $\lambda/4$ -λ transmission lines. (All references to lengths of lines are electrical length, and lines are assumed to have negligible loss.) See Fig 17. The magnitude of the *current* out of a  $\lambda/4$ -λ transmission line is equal to the *input* voltage divided by the characteristic impedance of the line, independent of the load impedance. In addition, the phase of the output current lags the phase of the input voltage by 90°, also independent of the load impedance. This property can be used to advantage in feeding arrays with certain phasings between elements.

If any number of loads are connected to a common driving point through  $\lambda/4$ -λ lines of equal impedance, the currents in the loads will be *forced* to be equal and in phase, regardless of the load impedances. So any number of in-phase elements can be correctly fed using this method. Arrays which require unequal currents can be fed through lines of unequal impedance to achieve other current ratios.

The properties of  $\lambda/2$ -λ lines also are useful. Since the current out of a  $\lambda/2$ -λ line equals the input current shifted 180°, regardless of the load impedance, any number of half wavelengths of line may be added to the basic  $\lambda/4$  λ, and the current and phase “forcing” property will be preserved. For example, if one element is fed through a  $\lambda/4$ -λ line, and another element is fed from the same point through a  $3/4$ -λ line of the same characteristic impedance, the currents in the two elements will be forced to be equal in magnitude and 180° out of phase, regardless of the feed-point impedances of the elements.

If an array of two identical elements is fed in phase or 180° out of phase, both elements have the same feed-point impedance. With these arrays, feeding the elements through equal lengths of feed line (in phase) or lengths differing by 180° (out of phase) will lead to the correct current and phase



**Fig 17—A useful property of  $\lambda/4$ -λ transmission lines; see text. This property is utilized in the “current forcing” method of feeding an array of coupled elements.**

match, regardless of what the line length is. Unless the lines are an integral number of half wavelengths long, the currents out of the lines will not be equal to the input currents, and the phase will not be shifted an amount equal to the electrical lengths of the lines. But both lines will produce the same transformation and phase shift because their load impedances are equal, resulting in a properly fed array. In practice, however, feed-point impedances of elements frequently are different even in these arrays, because of such things as different ground systems (for vertical elements), proximity to buildings or other antennas, or different heights above ground (for horizontal elements).

In many larger arrays, two or more elements must be fed either in phase or out of phase with equal currents, but coupling to other elements may cause their impedances to change unequally—sometimes extremely so. Using the current-forcing method allows the feed system designer to ignore all these effects while guaranteeing equal and correctly phased currents in any combination of  $0^\circ$  and  $180^\circ$  fed elements.

### Feeding Elements in Quadrature

Many popular arrays have elements or groups of elements which are fed in quadrature ( $90^\circ$  relative phasing). A combination of the forcing method and a simple adjustable network can produce the correct current balance and element phasing.

Suppose that  $1/4\text{-}\lambda$  lines of the same impedance are connected to two elements. The magnitudes of the element currents equal the voltages at the feed-line inputs, divided by the characteristic impedance of the lines. The currents are both shifted  $90^\circ$  relative to the input voltages. If the two input voltages can be made equal in magnitude but  $90^\circ$  different in phase, the element currents will also be equal and phased at  $90^\circ$ . Many networks will accomplish the desired function, the simplest being the L network. Either a high-pass or low-pass network can be used. A high-pass network will give a phase lead, and a low-pass network causes a phase lag. The low-pass network offers dc continuity, which can be beneficial by eliminating static buildup. Only low-pass networks are described here.

The harmonic reduction properties of low-pass networks should not be a consideration in choosing the network type; antenna system matching components should not be depended upon to achieve an acceptable level of harmonic radiation. The quadrature feed system is shown in Fig 18.

For element currents of equal magnitude and  $90^\circ$  relative phase, equations for designing the network are

$$X_{\text{ser}} = \frac{Z_0^2}{R_2} \quad (\text{Eq 14})$$

$$X_{\text{sh}} = \frac{Z_0^2}{X_2 - R_2} \quad (\text{Eq 15})$$

where

- $X_{\text{ser}}$  = the reactance of the series component
- $X_{\text{sh}}$  = the reactance of the shunt component
- $Z_0$  = the characteristic impedance of the  $1/4\text{-}\lambda$  lines
- $R_2$  = the feed-point resistance of element 2
- $X_2$  = the feed-point reactance of element 2

$R_2$  and  $X_2$  may be calculated from Eqs 21 and 22, presented later. If  $X_{\text{ser}}$  or  $X_{\text{sh}}$  is positive, that component is an inductor; if negative, a capacitor. In most practical arrays,  $X_{\text{ser}}$  is an inductor, and  $X_{\text{sh}}$  is a capacitor.

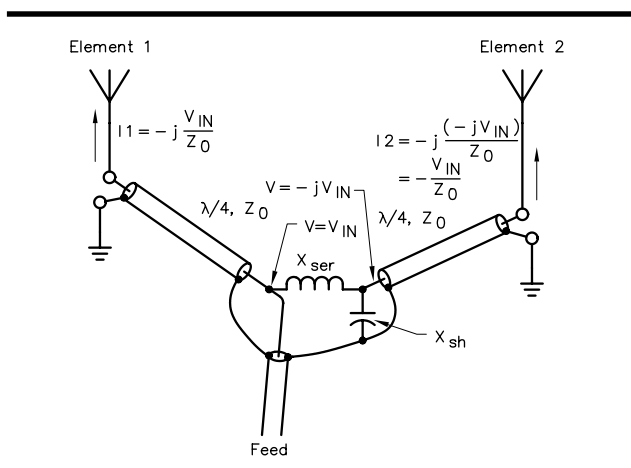
Unlike the current-forcing methods, the output-to-input voltage transformation and the phase shift of an L network *do* depend on the feed-point impedances of the array elements. So the impedances of the elements, when coupled to each other and while being excited to have the proper currents, must be known in order to design a proper L network. Methods for determining the impedance of one element in the presence of others are presented in later sections.

Suffice it to say here that the self-impedances of the elements and their mutual impedance must be known in order to calculate the element feed-point impedances. In practice, if simple dipoles or verticals are used, a rough estimation of self- and mutual impedances is generally enough to provide a starting point for determining the component values. Then the components may be adjusted for the desired array performance.

### The Magic Bullet

Two elements could be fed in quadrature without the necessity to determine self- and mutual impedances if a quadrature forcing network could be found. This passive network would have any one of the following characteristics, but the condition must be *independent of the network load impedance*:

- 1) The output voltage is equal in amplitude and  $90^\circ$  delayed or advanced in phase relative to the input voltage.



**Fig 18—Quadrature feed system. Equations in the text permit calculation of values for the L network components,  $X_{\text{ser}}$  and  $X_{\text{sh}}$ .**



- 2) The output current is equal in amplitude and  $90^\circ$  delayed or advanced in phase relative to the input current.
- 3) The output voltage is in phase or  $180^\circ$  out of phase with the input current, and the magnitude of the output voltage is related to the magnitude of the input current by a constant.
- 4) The output current is in phase or  $180^\circ$  out of phase with the input voltage, and the magnitude of the output current is related to the magnitude of the input voltage by a constant.

Such a network would be the *magic bullet* to extend the forcing method to quadrature feed systems. Lewallen has looked long and hard for this magic bullet without success. Among the many unsuccessful candidates is the  $90^\circ$  hybrid coupler. Like the Wilkinson divider, the hybrid coupler is a useful port-to-port isolation device that does not accomplish the needed function for this application. The feeding of amateur arrays could be greatly simplified by use of a suitable network. Any reader who is aware of such a network is encouraged to publish it in amateur literature, or to contact Lewallen or the editors of this book.

### PATTERN AND GAIN CALCULATION

The following equations are derived from those published by Brown in 1937. Findings from Brown's and later works are presented in concise form by Jasik. Equivalent equations may be found in other texts, such as *Antennas* by Kraus. (See the Bibliography at the end of this chapter.) The equations in this part will enable the mathematically inclined amateur armed with a calculator or computer to determine patterns, actual gains, and front-to-back or front-to-side ratios of two-element arrays. Although only two-element arrays are presented in detail in this part, the principles hold for larger arrays.

The importance of equal element currents (assuming identical elements) in obtaining the best possible nulls was explained earlier, dissimilar current distributions notwithstanding. Maximum forward gain is obtained usually, if not always, for two-element arrays when the currents are equal. Therefore, most of the equations in this part have been simplified to assume that equal element feed-point currents are produced. Just how this can be accomplished for many common array types has already been described briefly, and is covered in more detail later in this chapter. Equations that include the effects of unequal feed-point currents are also presented later in this chapter.

The equations given below are valid for horizontal or vertical arrays. However, ground-reflection effects must be taken into account when dealing with horizontal arrays, doubling the number of elements, which must be dealt with. In fact, the impedance and vertical radiation patterns of horizontal arrays over a reflecting surface (such as the ground) can be derived by treating the images as additional array elements.

For two-element arrays of identical elements with equal element currents, the field strength gain at a distant point

relative to a single similar element is

$$FSG = 10 \log \frac{(R_R + R_L) [1 + \cos(S \cos \theta + \phi_{12})]}{(R_R + R_L) + R_m \cos \phi_{12}} \quad (\text{Eq 16})$$

where

FSG = field strength gain, dB

$R_R$  = radiation resistance of a single isolated element

$R_L$  = loss resistance of a single element

S = element spacing in degrees

$\theta$  = direction from array (see Fig 19)

$\phi_{12}$  = phase angle of current in element 2 relative to element 1.  $\phi_{12}$  is negative if element 2 is delayed (lagging) relative to element 1

$R_m$  = mutual resistance between elements (see Fig 20).

### The Gain Equation

The gain value from Eq 16 is the *power gain* in dB, which equals the *field strength gain* in dB. Eq 16 should not be confused with equations used to calculate only the *shape* of the pattern. The above equation gives not only the shape of the pattern, but also the actual gain at each angle, relative to a single element.

The quantity for which the logarithm is taken in Eq 16 is composed of two major parts,

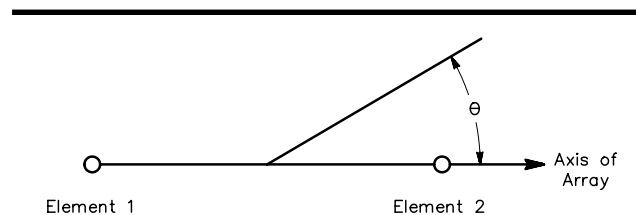


Fig 19—Definition of the angle  $\theta$  for pattern calculation.

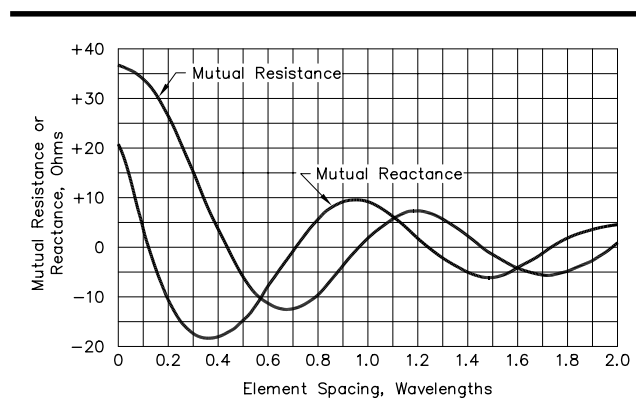


Fig 20—Mutual impedance between two parallel  $\frac{1}{4} \lambda$  vertical elements. Multiply the resistance and reactance values by two for  $\frac{1}{2} \lambda$  dipoles. Values for vertical elements that are between  $0.15 \lambda$  and  $0.25 \lambda$  high may be approximated by multiplying the given values by  $R_R/36$ , where  $R_R$  is the radiation resistance of the vertical given by graphs in Chapter 2.

$$1 + \cos(S \cos \theta + \phi_{12}) \quad (\text{Term 1})$$

which relates to field reinforcement or cancellation, and

$$\frac{R_L + R_L}{(R_R + R_L) + R_m \cos \phi_{12}} \quad (\text{Term 2})$$

which is the gain change caused by mutual coupling. It is informative to look at each of these terms separately, to see what effect they have on the overall gain.

If there were no mutual coupling at all, Eq 16 would reduce to

$$\text{FSG} = 10 \log [1 + \cos(S \cos \theta + \phi_{12})] \quad (\text{Eq 17})$$

The term

$$\cos(S \cos \theta + \phi_{12}) \quad (\text{Term 3})$$

can assume values from  $-1$  to  $+1$ , depending on the element spacing, current phase angle, and direction from the array. In the directions in which the term is  $-1$ , the gain becomes zero; a null occurs. Where the term is equal to  $+1$ , a maximum gain of

$$\text{FSG} = 10 \log 2 = 3 \text{ dB} \quad (\text{Eq 18})$$

occurs. This is the same conclusion reached earlier (Eq 13). If the element spacing is insufficient, the term will fail to reach  $-1$  or  $+1$  in any direction, resulting in incomplete nulls or reduced gain, or both. Analysis of the spacing required for the term to reach  $-1$  and  $+1$  results in the graphs of Fig 11.

Analyzing array operation without mutual coupling is not simply an intellectual exercise, even though mutual coupling is present in all arrays. There are some circumstances that will make the mutual coupling portion of the gain equation equal, or very nearly equal, to one. Term 2 above will equal one if

$$R_m \cos \phi_{12} \quad (\text{Term 4})$$

is equal to zero. This will happen if  $R_m = 0$ , which does occur at an element spacing of about  $0.43 \lambda$  (see Fig 20). Arrays don't usually have elements spaced at  $0.43 \lambda$ , but a much more common circumstance can cause the effect of mutual coupling on gain to be zero. Term 4 also equals zero if  $\phi_{12}$ , the phase angle between the element currents, is  $\pm 90^\circ$ . As a result, the gain of any two-element array with  $90^\circ$  phased elements is 3 dB in the favored directions, provided that the spacing is at least  $1/4 \lambda$ . The  $1/4\text{-}\lambda$  minimum is dictated by the requirement for full field reinforcement. If the elements are closer together, the gain will be less than 3 dB, as indicated in Fig 11.

### Loss Resistance and Antenna Gain

A circumstance that reduces the gain effects of mutual coupling is the presence of high losses. If the loss resistance,  $R_L$ , becomes very large, the  $R_R + R_L$  part of Term 2 above gets much larger than the  $R_m \cos \phi_{12}$  part. Then Term 2, the mutual coupling part of the gain equation, becomes approximately

$$\frac{R_R + R_L}{R_R + R_L} = 1$$

Thus, the gain of any very lossy two-element array is 3 dB relative to a single similar element, providing that the spacing is adequate for full field reinforcement. Naturally, higher losses will always lower the gain relative to a single *lossless* element.

This principle can be used to obtain substantial gain if an inefficient antenna system is in use. The technique is to construct one or more additional closely spaced elements (each with its own ground system), and feed the resulting array with all elements in phase. The array won't have appreciable directivity, but it will have significant gain if the original system is very inefficient. As losses increase, the gain approaches  $10 \log n$ , where  $n$  is the number of elements—3 dB for two elements. This gain, of course, is relative to the original lossy element, so the system gain is unlikely to exceed that of a single lossless element.

Why does a close-spaced second element provide gain? An intuitive way to understand it is to note that two or more closely spaced in-phase elements behave almost like a single element, because of mutual coupling. However, the ground systems are not coupled, so they behave like parallel resistors. The result is a more favorable ratio of radiation to loss resistance. In an efficient system, which has a favorable ratio to begin with, the improvement is not significant, but it can be very significant if the original antenna is inefficient.

The following example illustrates the use of this technique to improve the performance of a 1.8-MHz antenna system. Suppose the original system consists of a single 50-foot high vertical radiator with a 6-inch effective diameter. This antenna will have a radiation resistance,  $R_R$ , of  $3.12 \Omega$  at 1.9 MHz. A moderate ground system on a city lot will have a loss resistance,  $R_L$ , of perhaps  $20 \Omega$ . The efficiency of the antenna will be  $3.12/(20 + 3.12) = 13.5\%$ , or  $-8.7$  dB relative to a perfectly efficient antenna.

If a second 50-foot antenna with a similar ground system is constructed just 10 feet away from the first, the mutual resistance between elements will be  $3.86 \Omega$ . (Calculation of mutual resistance for very short radiators isn't covered in this chapter, but Brown shows that the mutual resistance between short radiators drops approximately in proportion to the self-resistance of each element.) Putting the appropriate values into Eq 16 shows an array gain of 2.34 dB relative to the original single element.

When the effects of mutual coupling are present, the gain in the favored direction can be greater or less than 3 dB, depending on the sign of Term 4. Analysis becomes easier if the element spacing is assumed to be sufficient for full field reinforcement. If this is true, the gain in the favored direction is

$$\begin{aligned} \text{FSG} &= 10 \log \frac{2(R_R + R_L)}{(R_R + R_L) + R_m \cos \phi_{12}} \\ &= 3 \text{ dB} + 10 \log \frac{R_R + R_L}{(R_R + R_L) + R_m \cos \phi_{12}} \end{aligned} \quad (\text{Eq 19})$$

Note that Term 4 above appears in the denominator of Eq 19. If maximum gain is the goal, this term should be made as negative as possible. One of the more obvious ways is to make  $\phi_{12}$ , the phase angle, be  $180^\circ$ , so that  $\cos \phi_{12} = -1$ , and space the elements closely to make  $R_m$  large and positive (see Fig 20). Unfortunately, close spacing does not permit total field reinforcement, so Eq 19 is invalid for this approach. However, the very useful gain of just under 4 dB is still obtainable with this concept if the loss is kept very low. The highest gains for two-element arrays (about 5.6 dB) occur at close spacings with feed angles just under  $180^\circ$ . All close-spaced, moderate to high-gain arrays are very sensitive to loss, so they generally will produce disappointing results when made with ground-mounted vertical elements.

Here are some examples which illustrate the use of Eq 16. Consider an array of two parallel,  $1/4\text{-}\lambda$  high, ground-mounted vertical elements, spaced  $1/2 \lambda$  apart and fed  $180^\circ$  out of phase. For this array,

$$\begin{aligned} R_R &= 36 \Omega \\ S &= 180^\circ \\ \phi_{12} &= 180^\circ \\ R_m &= -6 \Omega \text{ (from Fig 20)} \end{aligned}$$

$R_L$  must be measured or approximated, measurements being preferred for best accuracy. Suitable methods are described later. Alternatively,  $R_L$  can be estimated from graphs of ground-system losses. Probably the most extensive set of measurements of vertical antenna ground systems was published by Brown, et al in their classic 1937 paper. Their data have been republished countless times since, in amateur and other literature. Unfortunately, information is sparse for systems of only a few radials because Brown's emphasis is on broadcast installations. Measurements by Sevick nicely fill this void. From his data, we find that the typical feed-point resistance of a  $1/4\text{-}\lambda$  vertical with four 0.2 to 0.4- $\lambda$  radials is  $65 \Omega$ . (See Fig 24.) The loss resistance is  $65 - 36 = 29 \Omega$ . This value is used for the example.

Putting the values into Eq 16 results in

$$\text{FSG} = 10 \log \frac{65 [1 + \cos (180^\circ \cos \theta + 180^\circ)]}{65 + (-6 \cos 180^\circ)}$$

Calculating the result for various values of  $\theta$  reveals the familiar two-lobed pattern with maxima at  $0^\circ$  and  $180^\circ$ , and complete nulls at  $90^\circ$  and  $270^\circ$ . Maximum gain is calculated from Eq 16 by taking  $\theta$  as  $0^\circ$ .

$$\text{FSG} = 10 \log \frac{65(1+1)}{65+6} = 2.63 \text{ dB}$$

In this array, the mutual coupling decreases the gain slightly from the nominal 3-dB figure. The reader can confirm that if the element losses were zero ( $R_L = 0$ ), the gain would be 2.34 dB relative to a similar, lossless element. If the elements were extremely lossy, the gain would approach 3 dB relative to a single similar and very lossy element. The efficiency of the original example elements is

$36/65 = 55\%$ , and a single isolated element would have a signal strength of  $10 \log 36/65 = -2.57$  dB relative to a lossless element. As determined above, this phased array has a gain of 2.63 dB relative to a single 55% efficient element. Comparing the decibel numbers indicates the array performance in its favored directions is approximately the same as a single lossless element.

Changing the phasing of the array to  $0^\circ$  rotates the pattern  $90^\circ$ , and changes the gain to

$$\text{FSG} = 10 \log \frac{65 \times 2}{65 - 6} = 3.43 \text{ dB}$$

A system of very lossy elements would give 3 dB gain as before, and a lossless system would show 3.80 dB (each relative to a single similar element). In this case, the mutual coupling increases the gain above 3 dB, but the losses drop it back toward that figure. This effect can be generalized for larger arrays: Increasing loss in a system of  $n$  elements tends to move the gain toward  $10 \log n$  relative to a single similar (lossy) element, provided that spacing is adequate for full field reinforcement. If the spacing is closer, losses can reduce gain below this value.

## MUTUAL COUPLING AND FEED-POINT IMPEDANCE

The feed-point impedances of the elements of an array are important to the design of some of the feed systems presented here. When elements are placed in an array, their feed-point impedances change from the self-impedance values (impedances when isolated from other elements). The following information shows how to find the feed-point impedances of elements in an array.

The impedance of element 1 in a two-element array is given by Jasik as

$$R_1 = R_s + M_{12} (R_m \cos \phi_{12} - X_m \sin \phi_{12}) \quad (\text{Eq 20})$$

$$X_1 = X_s + M_{12} (X_m \cos \phi_{12} + R_m \sin \phi_{12}) \quad (\text{Eq 21})$$

where

$R_1$  = the feed-point resistance of element 1

$X_1$  = the feed-point reactance of element 1

$R_s$  = the self-resistance of a single isolated element = radiation resistance  $R_R$  + loss resistance  $R_L$

$X_s$  = the self-reactance of a single isolated element

$M_{12}$  = the magnitude of current in element 2 relative to that in element 1

$\phi_{12}$  = the phase angle of current in element 2 relative to that in element 1

$R_m$  = the mutual resistance between elements 1 and 2

$X_m$  = the mutual reactance between elements 1 and 2

For element 2,

$$R_2 = R_s + M_{21} (R_m \cos \phi_{21} - X_m \sin \phi_{21}) \quad (\text{Eq 22})$$

$$X_2 = X_s + M_{21} (X_m \cos \phi_{21} + R_m \sin \phi_{21}) \quad (\text{Eq 23})$$

where

$$M_{21} = \frac{1}{M_{12}}$$

$$\phi_{21} = -\phi_{12}$$

and other terms are as defined above.

Equations for the impedances of elements in larger arrays are given later.

### Two Elements Fed Out of Phase

Consider the earlier example of a two-element array of  $1/4$ - $\lambda$  verticals spaced  $1/2 \lambda$  apart and fed  $180^\circ$  out of phase. To find the element feed-point impedances, first the values of  $R_m$  and  $X_m$  are found from Fig 20. These are  $-6$  and  $-15 \Omega$ , respectively. Assuming that the element currents can be balanced and that the desired  $180^\circ$  phasing can be obtained, the feed-point impedance of element 1 becomes

$$R_1 = R_S + 1 [-6 \cos 180^\circ - (-15) \sin 180^\circ] = R_S + 6 \Omega$$

$$X_1 = X_S + 1 [-15 \cos 180^\circ + (-6) \sin 180^\circ] = X_S + 15 \Omega$$

Suppose that the elements, when not in an array, are resonant ( $X_S = 0$ ) and that they have good ground systems so their feed-point resistances ( $R_S$ ) are  $40 \Omega$ . The feed-point impedance of element 1 changes from  $40 + j 0$  for the element by itself to  $40 + 6 + j (0 + 15) = 46 + j 15 \Omega$ , because of mutual coupling with the second element. Such a change would be quite noticeable.

The second element in this array would be affected by the same amount, as the elements *look* the same to each other—there is no difference between  $180^\circ$  leading and  $180^\circ$  lagging. Mathematically, the difference in the calculation for element 2 involves changing  $+180^\circ$  to  $-180^\circ$  in the equations, leading to identical results. Elements fed in phase ( $\phi_{12} = 0^\circ$ ) also look the same to each other. So for two-element arrays fed in phase ( $0^\circ$ ) or out of phase ( $180^\circ$ ), the feed-point impedances of both elements change by the same amount and in the same direction because of mutual coupling. This is not generally true for a pair of elements that are part of a larger array, as a later example shows.

### Two Elements with $90^\circ$ Phasing

Now see what happens with two elements having a different relative phasing. Consider the popular vertical array with two elements spaced  $1/4 \lambda$  and fed with a  $90^\circ$  relative phase angle to obtain a cardioid pattern. Assuming equal element currents and  $1/4$ - $\lambda$  elements, Fig 20 shows that  $R_m = 20 \Omega$  and  $X_m = -15 \Omega$ . Use Eqs 19 and 20 to calculate the feed-point impedance of the leading element, and Eqs 21 and 22 for the lagging element.

$$R_1 = R_S + 1 [20 \cos(-90^\circ) - (-15) \sin(-90^\circ)] = R_S - 15 \Omega$$

$$X_1 = X_S + 1 [-15 \cos(-90^\circ) + 20 \sin(-90^\circ)] = X_S - 20 \Omega$$

And for the lagging element,

$$R_2 = R_S + 1 [20 \cos 90^\circ - (-15) \sin 90^\circ] = R_S + 15 \Omega$$

$$X_2 = X_S + 1 [(-15) \cos 90^\circ + 20 \sin 90^\circ] = X_S + 20 \Omega$$

These values represent quite a change in element impedance from mutual coupling. If each element, when isolated, is  $50 \Omega$  and resonant ( $50 + j 0 \Omega$  impedance), the impedances of the elements in the array become  $35 - j 20$

and  $65 + j 20 \Omega$ . These very different impedances can lead to current imbalance and serious phasing errors, if a casually designed or constructed feed system is used.

### Close-Spaced Elements

Another example provides a good illustration of several principles. Consider an array of two parallel  $1/2$ - $\lambda$  dipoles fed  $180^\circ$  out of phase and spaced  $0.1 \lambda$  apart. To avoid complexity in this example, assume these dipoles are a free-space  $1/2$ - $\lambda$  long, which is about 1.4% longer than a thin, resonant dipole. At this spacing, from Fig 20,  $R_m = 67 \Omega$  and  $X_m = 7 \Omega$ . (Remember to double the values from the graph of Fig 20 for dipole elements.) For each element,

$$R_1 = R_2 = R_S + 1 [67 \cos 180^\circ - 7 \sin 180^\circ] = R_S - 67 \Omega$$

$$X_1 = X_2 = X_S + 1 [7 \cos 180^\circ + 67 \sin 180^\circ] = X_S - 7 \Omega$$

The feed-point impedance of an isolated, free-space  $1/2$ - $\lambda$  dipole is approximately  $74 + j 44 \Omega$ . Therefore the elements in this array will each have an impedance of about  $74 - 67 + j (44 - 7) = 7 - j 37 \Omega$ ! Aside from the obvious problem of matching the array to a feed line, there are some other consequences of such a radical change in the feed-point impedance. Because of the very low feed-point impedance, relatively heavy current will flow in the elements. Normally this would produce a larger field strength, but note from Fig 13 that the element spacing ( $36^\circ$ ) is far below the  $180^\circ$  required for total field reinforcement. What happens here is that the fields from the elements of this array partially or totally cancel in all directions; there is no direction in which they fully reinforce. As a result, the array produces only moderate gain. Even a few ohms of loss resistance will dissipate a substantial amount of power, reducing the array gain.

This type of array was first described in 1940 by Dr. John Kraus, W8JK (see Bibliography). At  $0.1$ - $\lambda$  spacing, the array will deliver just under 4 dB gain if there is no loss, and just over 3 dB if there is 1- $\Omega$  loss per element. The gain drops to about 1.3 dB for 5  $\Omega$  of loss per element, and to zero dB at 10  $\Omega$ . These figures can be calculated from Eq 16 or read directly from the graphs in Kraus's paper. The modern W8JK array (presented later in this chapter) is based on the array just described, but it overcomes some of the above disadvantages by using four elements instead of two (two pairs of two half waves in phase). Doubling the size of the array provides a theoretical 3 dB gain increase over the above values, and feeding the array as pairs of half waves in phase increases the feed-point impedance to a more reasonable value. However, the modern W8JK array is still sensitive to losses, as described above, because of relatively high currents flowing in the elements.

### LARGER ARRAYS

As mentioned earlier, the feed-point impedance of any given element in an array of dipole or ground-mounted vertical elements is altered from its self-impedance by coupling to other elements in the array. Eqs 19, 20, 21 and 22 may be used to calculate the resistive and reactive

components of the elements in a two-element array. In a larger array, however, mutual coupling must be taken into account between any given element and all other elements in the array.

### Element Feed-Point Impedances

The equations presented in this section may be used to calculate element feed-point impedances in larger arrays. Jasik gives the impedance of an element in an n-element array as follows. For element 1,

$$R_1 = R_{11} + M_{12}(R_{12} \cos \phi_{12} - X_{12} \sin \phi_{12}) + M_{13}(R_{13} \cos \phi_{13} - X_{13} \sin \phi_{13}) + \dots + M_{1n}(R_{1n} \cos \phi_{1n} - X_{1n} \sin \phi_{1n}) \quad (\text{Eq 24})$$

$$X_1 = X_{11} + M_{12}(R_{12} \sin \phi_{12} + X_{12} \cos \phi_{12}) + M_{13}(R_{13} \sin \phi_{13} + X_{13} \cos \phi_{13}) + \dots + M_{1n}(R_{1n} \sin \phi_{1n} + X_{1n} \cos \phi_{1n}) \quad (\text{Eq 25})$$

For element p,

$$R_p = R_{pp} + M_{p1}(R_{p1} \cos \phi_{p1} - X_{p1} \sin \phi_{p1}) + M_{p2}(R_{p2} \cos \phi_{p2} - X_{p2} \sin \phi_{p2}) + \dots + M_{pn}(R_{pn} \cos \phi_{pn} - X_{pn} \sin \phi_{pn}) \quad (\text{Eq 26})$$

$$X_p = X_{pp} + M_{p1}(R_{p1} \sin \phi_{p1} + X_{p1} \cos \phi_{p1}) + M_{p2}(R_{p2} \sin \phi_{p2} + X_{p2} \cos \phi_{p2}) + \dots + M_{pn}(R_{pn} \sin \phi_{pn} + X_{pn} \cos \phi_{pn}) \quad (\text{Eq 27})$$

And for element n,

$$R_n = R_{nn} + M_{n1}(R_{n1} \cos \phi_{n1} - X_{n1} \sin \phi_{n1}) + M_{n2}(R_{n2} \cos \phi_{n2} - X_{n2} \sin \phi_{n2}) + \dots + M_{n(n-1)}(R_{n(n-1)} \cos \phi_{n(n-1)} - X_{n(n-1)} \sin \phi_{n(n-1)}) \quad (\text{Eq 28})$$

$$X_n = X_{nn} + M_{n1}(R_{n1} \sin \phi_{n1} + X_{n1} \cos \phi_{n1}) + M_{n2}(R_{n2} \sin \phi_{n2} + X_{n2} \cos \phi_{n2}) + \dots + M_{n(n-1)}(R_{n(n-1)} \sin \phi_{n(n-1)} + X_{n(n-1)} \cos \phi_{n(n-1)}) \quad (\text{Eq 29})$$

where

- $R_{jj}$  = self resistance of element j
- $X_{jj}$  = self reactance of element j
- $M_{jk}$  = magnitude of current in element k relative to that in element j
- $R_{jk}$  = mutual resistance between elements j and k
- $X_{jk}$  = mutual reactance between elements j and k
- $\phi_{jk}$  = phase angle of current in element k relative to that in element j

These are more general forms of Eqs 19 and 20. Examples of using these equations appear in a later section.

### Quadrature Fed Elements in Larger Arrays

In some arrays, groups of elements must be fed in quadrature. Such a system is shown in Fig 21. The current in each element in the left-hand group equals

$$I_1 = -j \frac{V_{in}}{Z_0} \quad (\text{Eq 30})$$

The current in the elements in the right-hand group equals

$$I_2 = -j \frac{V_{out}}{Z_0} \quad (\text{Eq 31})$$

Thus, if  $V_{out} = -jV_{in}$ , the right-hand group will have currents equal in magnitude to and 90° delayed from the currents in the left-hand group. The feed-point resistances of the elements have nothing to do with determining the current relationship, except that the relationship between  $V_{out}$  and  $V_{in}$  is a function of the impedance of the load presented to the L network. That load is determined by the impedances of the elements in the right-hand group.

Values of network components are given by

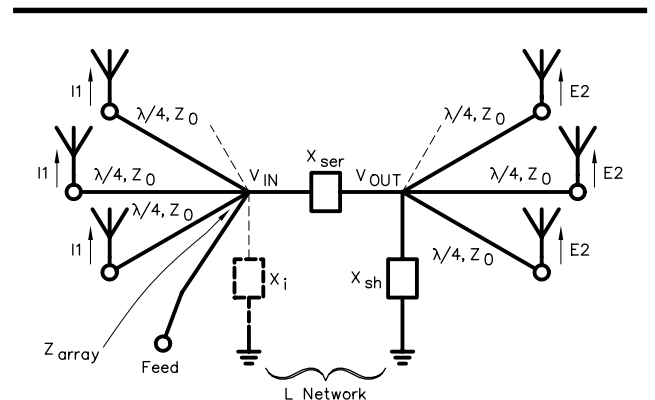
$$X_{ser} = \frac{Z_0^2}{\sum R_2} \quad (\text{Eq 32})$$

$$X_{sh} = \frac{Z_0^2}{\sum X_2 - \sum R_2} \quad (\text{Eq 33})$$

where

- $X_{ser}$  = the reactance of the series network element
- $X_{sh}$  = the reactance of the shunt network element (at the output side)
- $Z_0$  = the characteristic impedance of the element feed lines
- $\sum R_2$  = the sum of the feed-point resistances of all elements connected to the output side of the network
- $\sum X_2$  = the sum of the feed-point reactances of all elements connected to the output side of the network

These are more general forms of Eqs 13 and 14. If the value of  $X_{ser}$  or  $X_{sh}$  is positive, that component is an inductor; if negative, a capacitor.



**Fig 21—The L network applied to larger arrays. Coaxial cable shields and ground connections for the elements have been omitted for clarity. The text gives equations for determining the component values of  $X_{ser}$ ,  $X_{sh}$  and  $X_i$ .  $X_i$  is an optional impedance matching component.**

## Array Impedance and Array Matching

Although the impedance matching of an array to the main feed line is not covered in any depth in this chapter, simply adding  $X_i$  to the L network, as shown in Fig 21, can improve the match of the array.  $X_i$  is a shunt component with reactance, added at the network input. With the proper  $X_i$ , the array common-point impedance is made purely resistive, improving the SWR or allowing Q-section matching.  $X_i$  is determined from

$$X_i = \frac{Z_0^2}{\sum X_1 - \sum R_2} \quad (\text{Eq 34})$$

where

$X_i$  = the reactance of the shunt network matching element (at the input side)

$\sum X_1$  = the sum of the feed-point reactances of all elements connected to the input side of the network and other terms are as defined above

If the value of  $X_i$  is positive, the component is an inductor; if negative, a capacitor. With the added network element in place, the array common-point impedance is

$$Z_{\text{array}} = \frac{Z_0^2}{\sum R_1 + \sum R_2} \quad (\text{Eq 35})$$

where

$\sum R_1$  = the sum of the feed-point resistances of all elements connected to the input side of the network and other terms are as described above.

$X_{\text{ser}}$  and  $X_{\text{sh}}$  should be adjusted for correct phasing and current balance as described later. They should not be adjusted for the best SWR.  $X_i$ , only, is adjusted for the best SWR, and has no effect on phasing or current balance.

## CURRENT IMBALANCE AND ARRAY PERFORMANCE

The result of phase error in a driven array was discussed earlier. Changes in phase from the design value produce pattern changes such as shown in Fig 15. Now we turn our attention to the effects of current amplitude imbalance in the elements. This requires the introduction of more general gain equations to take the current ratio into account; the equations given earlier are simplified, based on equal element currents.

### Gain, Nulls, and Null Depth

A more general form of Eq 16, taking the current ratios into account, is

$$\text{FSG} = 10 \log \frac{(R_R + R_L) [1 + M_{12}^2 + 2M_{12} \cos(S \cos \theta + \phi_{12})]}{(R_R + R_L) (1 + M_{12}^2) + 2M_{12} R_m \cos \phi_{12}} \quad (\text{Eq 36})$$

where

FSG = field strength gain relative to a single, similar element, dB

$M_{12}$  = the magnitude of current in element 2 relative to

the current in element 1. and other symbols are as defined for Eq 16.

Eq 36 may be used to determine the array field strength at a distant point relative to that from a single similar element for any spacing of two array elements. Now consider arrays where the spacing is sufficient for total field reinforcement or total field cancellation, or both. Fig 13 shows the spacings necessary to achieve these conditions. The curves of Fig 13 show spacings which will allow the term

$$\cos(S \cos \theta + \phi_{12})$$

to equal its maximum possible value of +1 (total field reinforcement) and minimum possible value of -1 (total field cancellation). In reality, the fields from the two elements cannot add to zero unless this term is -1 and the element currents and distributions are equal. For a given set of element currents, the directions in which the term is +1 are those of maximum gain, and the directions in which the term is -1 are those of the deepest nulls.

The elements in many arrays are spaced at least as far apart as given by the two curves in Fig 13. Considerable simplification results in gain calculations for unequal currents if it is assumed that the elements are spaced to satisfy the conditions of Fig 13. Such simplified equations follow.

In the directions of maximum signal,

$$\text{FSG} = 10 \log \frac{(R_R + R_L) (1 + M_{12}^2)^2}{(R_R + R_L) (1 + M_{12}^2) + 2M_{12} R_m \cos \phi_{12}} \quad (\text{Eq 37})$$

This is a more general form of Eq 19, and is valid provided that the element spacing is sufficient for total field reinforcement. In the directions of minimum gain (nulls),

$$\text{FSG at nulls} = 10 \log \frac{(R_R + R_L) (1 - M_{12}^2)^2}{(R_R + R_L) (1 + M_{12}^2) + 2M_{12} R_m \cos \phi_{12}} \quad (\text{Eq 38})$$

This equation is valid if the spacing is enough for total field cancellation. The "front-to-null" ratio can be calculated by combining the above two equations.

$$\text{Front-to-null ratio} = 10 \log \frac{(1 + M_{12}^2)^2}{(1 - M_{12}^2)^2} \quad (\text{Eq 39})$$

This equation is valid if the spacing is sufficient for total field reinforcement and cancellation. The equation for forward gain is further simplified for those special cases where

$$R_m \cos \phi_{12} \quad (\text{Term 5})$$

is equal to zero. (See the discussion of Eq 16 and Term 4 in the earlier section, "The Gain Equation.")

$$\text{FSG} = 10 \log \frac{(1 + M_{12}^2)^2}{1 + M_{12}^2} \quad (\text{Eq 40})$$

This equation is valid if the element spacing is sufficient for total field reinforcement.

If an array is more closely spaced than indicated above, the gain will be less, the nulls poorer, or front-to-null ratio worse than given by Eqs 37, 38, 39 and 40. Eq 36 is valid regardless of spacing.

Graphs of Eqs 39 and 40 are shown in Fig 22. Note that the “forward gain” curve applies only to arrays for which Term 5, above, equals zero (which includes all two-element arrays phased at 90° and spaced at least 1/4 λ). The curve is useful, however, to get a ballpark idea of the gain of other arrays. The “front-to-null” curve applies to any two-element array, provided that spacing is wide enough for both full reinforcement and cancellation. Fig 22 clearly shows that current imbalance affects the front-to-null ratio much more strongly than it affects forward gain.

If the two elements have different loss resistances (for example, from different ground systems in a vertical array), gain relative to a single *lossless* element can still be calculated

$$FSG = 10 \log \frac{R_R [1 + M_{12}^2 + 2M_{12} \cos(S \cos \theta + \phi_{12})]}{(R_R + R_{L1}) + M_{12}^2 (R_R + R_{L2}) + 2M_{12} R_m \cos \phi_{12}} \quad (\text{Eq 41})$$

where

the gain is relative to a lossless element

$R_{L1}$  = loss resistance of element 1

$R_{L2}$  = loss resistance of element 2.

### Current Errors with Simple Feed Systems

It has already been said that casually designed feed systems can lead to poor current balance and improper phasing. To illustrate just how significant the errors can be, consider various arrays with typical feed systems.

The first array consists of two resonant, 1/4-λ ground-mounted vertical elements, spaced 1/4 λ apart. Each element has a feed-point resistance of 65 Ω when the other element

is open circuited. This is the approximate value when four radials per element are used. In an attempt to obtain 90° relative phasing, element 1 is fed with a line of electrical length  $L_1$ , and element 2 is fed with a line 90 electrical degrees longer ( $L_2$ ). The results appear in Table 2.

Not only is the magnitude of the current ratio off by as much as nearly 40%, but the phase angle is incorrect by as much as 30°! The pattern of the array fed with feed system number 1 is shown in Fig 23, with a correctly fed array pattern for reference. Note that the example array has only a 9.0 dB front-to-back ratio, although the forward gain is only 0.1 dB more than the correctly fed array. This pattern was calculated from Eq 36. Similar current distributions in the elements are assumed.

Results will be different for arrays with different ground systems. For example, if the array fed with feed system 1 had elements with an initial feed-point resistance of 40 Ω

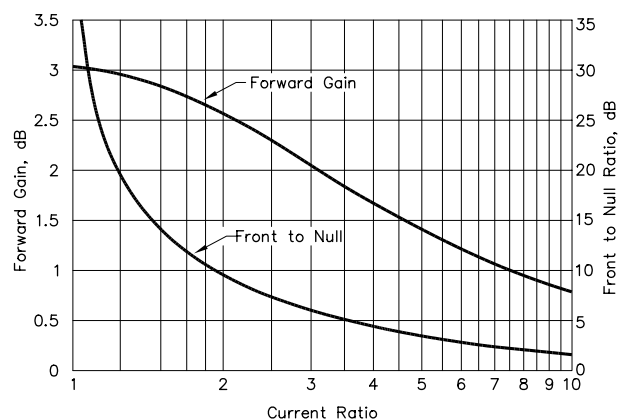


Fig 22—Effect of element current imbalance on forward gain and front-to-null ratio for certain arrays. See text.

Table 2

### Two 1/4-λ Vertical Elements with 1/4 λ Spacing

Feeder system: Line lengths to elements 1 and 2 are given below as  $L_1$  and  $L_2$ , respectively. The line length to element 2 is electrically 90° longer than to element 1.

No.	Feed Lines			Ele. Feed Point Impedances		Ele. Current Ratio	
	$Z_0$ , Ω	$L_1$ , Deg.	$L_2$ , Deg.	$Z_1$ , Ω	$Z_2$ , Ω	Mag.	Phase, Deg.
1	50	90	180	50.8 - j 6.09	69.8 + j 40.0	0.620	-120
2	75	90	180	45.1 - j 14.0	73.3 + j 24.3	0.973	-108
3	50	180	270	45.7 - j 14.1	73.9 + j 24.6	0.956	-107
4	75	180	270	51.5 - j 11.4	79.4 + j 32.4	0.705	-103
5	50	45	135	45.2 - j 8.44	68.5 + j 28.9	0.859	-120
6	75	45	135	50.2 - j 14.9	79.4 + j 26.1	0.840	-98
7	Correctly fed			50.0 - j 20.0	80.0 + j 20.0	1.000	-90

**Table 3**

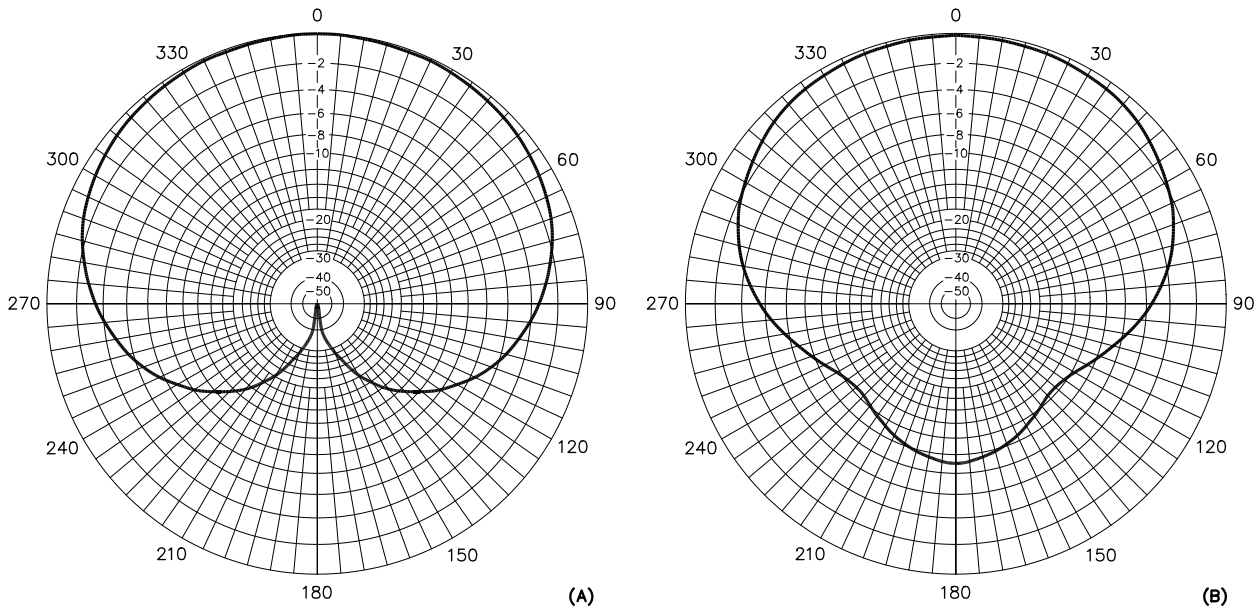
**Two  $\frac{1}{4}\lambda$  Vertical Elements with  $\frac{1}{2}\lambda$  Spacing and Different Self-Resistances**

Self-resistances: Element 1—50  $\Omega$ ; Element 2—65  $\Omega$  (difference caused by different ground losses). Feeder system: Line lengths to elements 1 and 2 are given below as  $L_1$  and  $L_2$ , respectively.

No.	Feed Lines			Ele. Feed Point Impedances		Ele. Current Ratio	
	$Z_0$ , $\Omega$	$L_1$ , Deg.	$L_2$ , Deg.	$Z_1$ , $\Omega$	$Z_2$ , $\Omega$	Mag.	Phase, Deg.
1	Any*	180	180	45.9 - j 12.2	56.5 - j 18.3	0.800	+3.1
2	50	135	135	43.8 - j 11.9	59.7 - j 18.6	0.834	-5.8
3	75	135	135	43.2 - j 12.5	60.3 - j 17.7	0.883	-6.8
4	Any*	270†	270†	44.0 - j 15.0	59.0 - j 15.0	1.000	0.0
5	50	45	225	53.2 + j 12.9	74.8 + j 17.1	0.820	-172
6	Any*	180	360	55.6 + j 11.0	71.1 + j 20.2	0.764	-185
7	Any*	90†	270†	56.0 + j 15.0	71.0 + j 15.0	1.000	-180

\*Both lines must have the same  $Z_0$

†Current forced



**Fig 23—Patterns of an array when correctly fed, A, and when casually fed, B. (See text. Similar current distributions are assumed.) The difference in gain is about 0.1 dB. Gain is referenced to a single similar element; add 3.1 dB to the scale values shown.**

instead of 65  $\Omega$ , the current ratio would be almost exactly 1—but the phase angle would still be  $-120^\circ$ , resulting in poor nulls. The forward gain of the array is +4.0 dB, but the front-to-back ratio is only 11.5 dB.

The advantage of using the current-forcing method to feed arrays of in-phase and  $180^\circ$  out-of-phase elements is shown by the following example. Suppose that the ground systems of two half-wave spaced,  $\frac{1}{4}\lambda$  vertical elements are slightly different, so that one element has a feed-point resistance of 50  $\Omega$ , the other 65  $\Omega$ . (Each is measured when

the other element is open circuited.) What happens in this case is shown in **Table 3**.

The patterns of the nonforced arrays are only slightly distorted, with the main deficiency being imperfect nulls. The in-phase array fed with feed system number 1 exhibits a front-to-side ratio of 18.8 dB. The out-of-phase array fed with feed system number 6 has a front-to-side ratio of 17.0 dB. Both these arrays have forward gains very nearly equal to that of a correctly fed array.

Even when the ground systems of the two elements are



only slightly different, a substantial current imbalance can occur in in-phase and 180° out-of-phase arrays if casually fed. Two elements with feed-point resistances of 36 Ω and 41 Ω (when isolated), fed with 1/2 and 1 λ of line, respectively, will have a current ratio of 0.881. This is a significant error for a

small resistance difference that may be impossible to avoid in practice. As explained earlier, two horizontal elements of different heights, or two elements in many larger arrays, even when fed in phase or 180° out of phase, require more than a casual feed system for correct current balance and phasing.

## Phased Array Design Examples

This section, also written by Roy Lewallen, W7EL, presents four examples of practical arrays using the design principles given in previous sections. All arrays are assumed to be made of 1/4-λ vertical elements.

### General Array Design Considerations

If the quadrature feed system (Fig 18) is used, the self-impedance of one or more elements must be known. If the elements are common types, such as plain vertical wires or tubes, the impedance can be estimated quite closely from the graphs in Chapter 2. Elements that are close to 1/4-λ high will be near resonance, and calculations can be simplified by adjusting each element to exact resonance (with the other element open-circuited at the feed point) before proceeding. If the elements are substantially less than 1/4 λ high, they will have a large amount of capacitive reactance. This should be reduced in order to keep the SWR on the feed lines to a value low enough to prevent large losses, possible arcing, or other problems. Any tuning or loading done to the elements at the feed point must be in *series* with the elements, so as not to shunt any of the carefully balanced current to ground. A loading coil in series with a short element is permissible, provided that all elements have identical loading coils, but any shunt component at the element feed point must be avoided.

For the following examples, it is assumed that the elements are close to 1/4 λ high and that they have been adjusted for resonance. The radiation resistance of each element is then close to 36 Ω, and the self-reactance is zero because it is resonant.

In any real vertical array, there is ground loss associated with each element. The amount of loss depends on the length and number of ground radials, and on the type and wetness of the ground under and around the antenna. This resistance appears in series with the radiation resistance. The self-resistance is the sum of the radiation resistance and the loss resistance. Fig 24 gives resistance values for typical ground systems, based on measurements by Sevick (July 1971 and March 1973 *QST*). The values of quadrature feed system components based on Fig 24 will be reasonably close to correct, even if the ground characteristics are somewhat different than Sevick's.

Feed systems for the design example arrays to follow are based on the resistance values given below.

Number of Radials	Loss Resistance, Ω
4	29
8	18
16	9
Infinite	0

The mutual impedance of the elements also must be known in order to calculate the impedances of the elements when in the array. The mutual impedance of parallel elements of near-resonant length may be taken from Fig 20. For elements of different lengths, or for unusual shape or orientation, the mutual impedance is best determined by measurement, using measurement methods as given later. Fig 20 suffices for the mutual impedance values in the example arrays.

The matter of matching the array for the best SWR on the feed line to the station is not discussed here. Many of the simpler arrays provide a match that is close to 50 or 75 Ω, so no further matching is required. If better matching is necessary, the appropriate network should be placed in the single feed line running to the station. Attempts to improve the match by adjustment of the phasing L network, antenna lengths, or individual element feeder lengths will ruin the current balance of the array. Information on impedance matching may be found in Chapters 25 and 26.

### 90° FED, 90° SPACED ARRAY

The feed system for a 90° fed, 90° spaced array is shown in Fig 18. The values of the inductor and capacitor must be calculated, at least approximately. The exact values can be determined by adjustment.

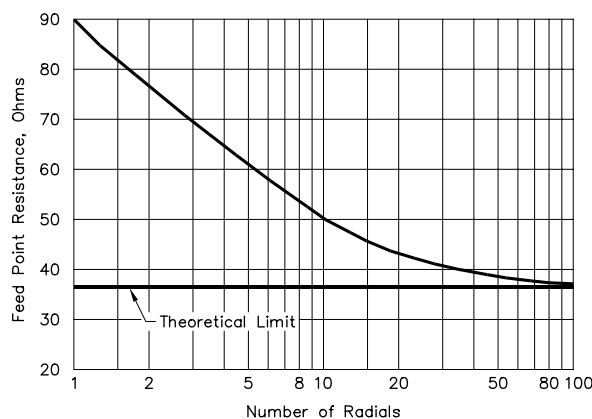


Fig 24—Approximate feed point resistance of a resonant 1/4-λ ground-mounted vertical element versus the number of radials, based on measurements by Jerry Sevick, W2FMI. Moderate length radials (0.2 to 0.4 λ) were used for the measurements. The exact resistance, especially for only a few radials, will depend on the nature of the soil under the antenna.

In this example the elements are assumed to be close to  $\frac{1}{4} \lambda$  high, and each is assumed to have been adjusted for resonance with the other element open circuited. If each element has, say, four ground radials, the ground loss resistance is approximately  $29 \Omega$ . The self-resistance is  $65 \Omega$ . The self-reactance is zero, as the elements are resonant. From Fig 20, the mutual resistance of two parallel  $\frac{1}{4}\lambda$  verticals spaced  $\frac{1}{4} \lambda$  apart is  $20 \Omega$ , and the mutual reactance is  $-15 \Omega$ . These values are used in Eqs 20, 21, 22 and 23 to calculate the feed-point impedances of the elements. Element currents of equal magnitude are required, so  $M_{12} = M_{21} = 1$ . The L network causes the current in element 2 to lag that in element 1 by  $90^\circ$ , so  $\phi_{12} = -90^\circ$  and  $\phi_{21} = 90^\circ$ . Summarizing,

$$\begin{aligned} R_S &= 65 \Omega \\ X_S &= 0 \Omega \\ M_{12} &= M_{21} = 1 \\ \phi_{12} &= -90^\circ \\ \phi_{21} &= 90^\circ \\ R_m &= 20 \Omega \\ X_m &= -15 \Omega \end{aligned}$$

Putting these values into Eqs 19, 20, 21 and 22 results in the following values.

$$\begin{aligned} R_1 &= 50 \Omega \\ X_1 &= -20 \Omega \\ R_2 &= 80 \Omega \\ X_2 &= 20 \Omega \end{aligned}$$

These are the actual impedances at the bases of the two elements when placed in the array and fed properly. It is necessary only to know the impedance of element 2 in order to design the L network, but the impedance of element 1 was calculated here to show how different the impedances are. Next, the impedance of the feed lines is chosen. Suppose the choice is  $50 \Omega$ . For Eqs 14 and 15,

$$\begin{aligned} Z_0 &= 50 \Omega \\ R_2 &= 80 \Omega \\ X_2 &= 20 \Omega \end{aligned}$$

From Eq 14,

$$X_{ser} = \frac{50^2}{80} = 31.3 \Omega$$

And from Eq 15,

$$X_{sh} = \frac{50^2}{20 - 80} = -41.7 \Omega$$

The signs show that  $X_{ser}$  is an inductor and  $X_{sh}$  is a capacitor. The actual values of L and C can be calculated for the desired frequency by rearranging and modifying the basic equations for reactance.

$$L = \frac{X_L}{2\pi f} \quad (\text{Eq 42})$$

$$C = \frac{-10^6}{2\pi f X_C} \quad (\text{Eq 43})$$

where

$$\begin{aligned} L &= \text{inductance, } \mu\text{H} \\ C &= \text{capacitance, pF} \\ f &= \text{frequency, MHz} \\ X_L \text{ and } X_C &= \text{reactance values, } \Omega \end{aligned}$$

The negative sign in Eq 43 is included because capacitive reactance values are given here as negative. A similar process is followed to find the values of  $X_{ser}$  and  $X_{sh}$  for different ground systems and different feed-line impedances. The results of such calculations appear in Table 4.

To obtain correct performance, both network components must be adjustable. If an adjustable inductor is not convenient or available, a fixed inductor in series with a variable capacitor will provide the required adjustability. The equivalent reactance should be equal to the value calculated for  $X_{ser}$ .

For example, to use the above design at 7.15 MHz,  $L_{ser} = 0.697 \mu\text{H}$ , and  $C_{sh} = 534 \text{ pF}$ . The  $0.697 \mu\text{H}$  inductor (reactance =  $31.3 \Omega$ ) can be replaced by a  $1.39 \mu\text{H}$  inductor (reactance = approximately  $62.6 \Omega$ ) in series with a variable capacitor capable of being adjusted on both sides of  $711 \text{ pF}$  (reactance =  $-31.3 \Omega$ ). The reactance of the series combination can then be varied on both sides of  $62.6 - 31.3 = 31.3 \Omega$ . Actually, it might be preferable to use  $75\text{-}\Omega$  feed line instead of  $50 \Omega$  for this array. Table 4 shows that the L network reactances are about twice as great if  $75\text{-}\Omega$  line is chosen. This means that the required capacitance would be one half as large. Smaller adjustable capacitors are more common, and more compact.

The voltages across the network components are relatively low. Components with breakdown voltages of a few hundred volts will be adequate for a few hundred watts of output power. If fixed capacitors are used, they should be good quality mica or ceramic units.

### A THREE-ELEMENT BINOMIAL BROADSIDE ARRAY

An array of three in-line elements spaced  $\frac{1}{2} \lambda$  apart and fed in phase gives a pattern that is generally bidirectional. If the element currents are equal, the resulting pattern has a forward gain of 5.7 dB (for lossless elements) but substantial side lobes. If the currents are tapered in a binomial coefficient

**Table 4**  
**L Network Values for Two Elements  $\frac{1}{4} \lambda$  Apart, Fed  $90^\circ$  Out of Phase (Fig 18)**

$R_S$ , $\Omega$	No. of Radials per Element	$Z_0$ , $\Omega$	$X_{ser}$ $\Omega$	$X_{sh}$ $\Omega$
65	4	50	31.3	-41.7
65	4	75	70.3	-93.8
54	8	50	36.2	-51.0
54	8	75	81.5	-114.8
45	16	50	41.7	-62.5
45	16	75	93.8	-140.6
36	$\infty$	50	49.0	-80.6
36	$\infty$	75	110.3	-181.5

1:2:1 ratio (twice the current in the center element as in the two end elements), the gain drops slightly to 5.2 dB, the main lobes widen, and the side lobes disappear.

The array is shown in Fig 25. To obtain a 1:2:1 current ratio in the elements, each end element is fed through a  $3/4\text{-}\lambda$  line of impedance  $Z_0$ . Line lengths of  $3/4\text{-}\lambda$  are chosen because  $1/4\text{-}\lambda$  lines will not physically reach. The center element is fed from the same point through two parallel  $3/4\text{-}\lambda$  lines of the same characteristic impedance, which is equivalent to feeding it through a line of impedance  $Z_0/2$ . The currents are thus forced to be in phase and to have the correct ratio.

### A FOUR-ELEMENT RECTANGULAR ARRAY

The four-element array shown with its pattern in Fig 26 has appeared numerous times in amateur publications. However, the accompanying feed systems invariably fail to deliver currents in the proper amounts and phases to the various elements. The array can be correctly fed using the principles discussed in this section.

Elements 1 and 2 can be forced to be in phase and to have equal currents by feeding them through  $3/4\text{-}\lambda$  lines. (Again,  $3/4\text{-}\lambda$  lines are chosen because  $1/4\text{-}\lambda$  lines won't physically reach.) Likewise, the currents in elements 3 and 4 can be forced to be equal and in phase. Elements 3 and 4 are made to have currents of equal amplitude but of  $90^\circ$  phase difference from elements 1 and 2 by use of the quadrature

feed system shown in Fig 27. The phasing network is the type shown in Fig 18, but Eqs 32 and 33 must be used to calculate the network component values. For this array they are

$$X_{\text{ser}} = \frac{Z_0^2}{R_3 + R_4} = \frac{Z_0^2}{2R_3} \quad (\text{Eq 44})$$

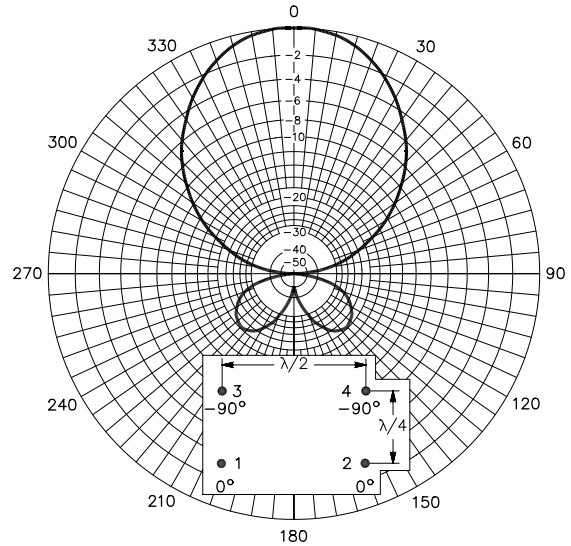


Fig 26—Pattern and layout of the four-element rectangular array. Gain is referenced to a single similar element; add 6.8 dB to the scale values shown.

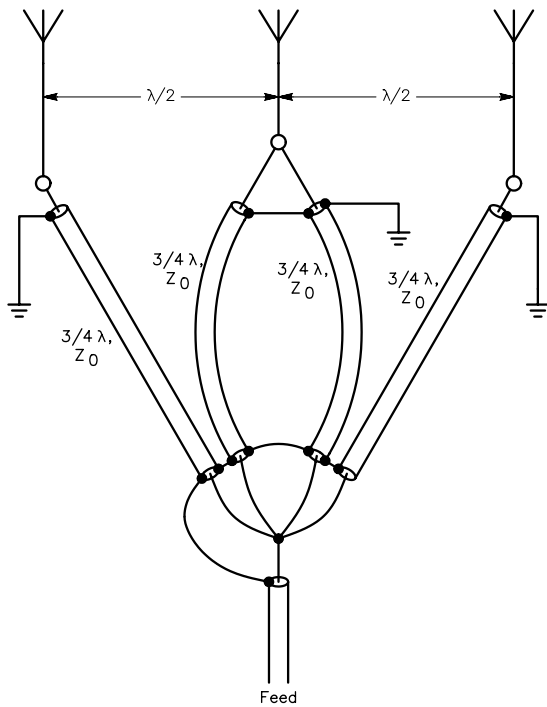


Fig 25—Feed system for the three element 1:2:1 binomial array. All feed lines are  $3/4$  electrical wavelength long and have the same characteristic impedance.

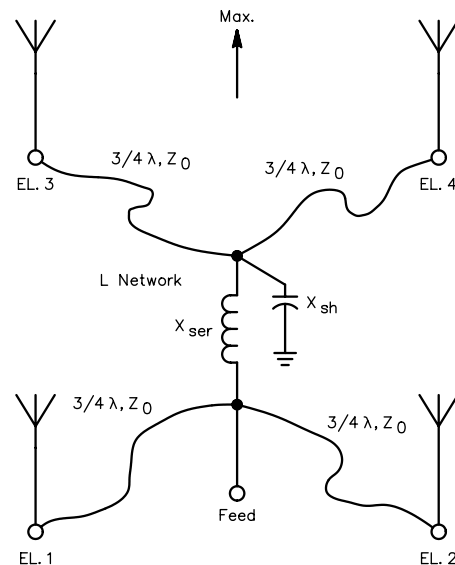


Fig 27—Feed system for the four-element rectangular array. Grounds and cable shields have been omitted for clarity.

$$X_{sh} = \frac{Z_0^2}{X_3 + X_4 - (R_3 + R_4)} = \frac{Z_0^2}{2(X_3 - R_3)} \quad (\text{Eq 45})$$

The impedances of elements 3 and 4 will change by the same amount because of mutual coupling. If their ground systems are identical, they will also have equal values of  $R_L$ . If the ground systems are different, an adjustment of network values must be made, but the currents in all elements will be equal and correctly phased once the network is adjusted.

Eqs 26 and 27 are used to calculate  $R_3$  and  $X_3$ . For element 3, they become

$$\begin{aligned} R_3 &= R_S + M_{31}(R_{31} \cos \phi_{31} - X_{31} \sin \phi_{31}) + \\ &M_{32}(R_{32} \cos \phi_{32} - X_{32} \sin \phi_{32}) + \\ &M_{34}(R_{34} \cos \phi_{34} - X_{34} \sin \phi_{34}) \\ X_3 &= X_S + M_{31}(R_{31} \sin \phi_{31} + X_{31} \cos \phi_{31}) + \\ &M_{32}(R_{32} \sin \phi_{32} + X_{32} \cos \phi_{32}) + \\ &M_{34}(R_{34} \sin \phi_{34} + X_{34} \cos \phi_{34}) \end{aligned}$$

where

$$\begin{aligned} M_{31} &= M_{32} = M_{34} = 1 \\ \phi_{31} &= +90^\circ \\ \phi_{32} &= +90^\circ \\ \phi_{34} &= 0^\circ \\ R_{31} &= 20 \Omega \text{ (from Fig 20, } 0.25\text{-}\lambda \text{ spacing)} \\ X_{31} &= -15 \Omega \text{ (} 0.25\text{-}\lambda \text{ spacing)} \\ R_{32} &= -10 \Omega \text{ (} 0.56\text{-}\lambda \text{ spacing)} \\ X_{32} &= -10 \Omega \text{ (} 0.56\text{-}\lambda \text{ spacing)} \\ R_{34} &= -6 \Omega \text{ (} 0.50\text{-}\lambda \text{ spacing)} \\ X_{34} &= -15 \Omega \text{ (} 0.50\text{-}\lambda \text{ spacing)} \end{aligned}$$

resulting in  $R_3 = R_S + 19 \Omega$  and  $X_3 = X_S - 5.0 \Omega$ .  $R_S$  and  $X_S$  are the self-resistance and self-reactance of a single isolated element. In this example, they are assumed to be the same for all elements. Thus, element 4 will have the same impedance as element 3.

It is now possible to make a table of  $X_{ser}$  and  $X_{sh}$  values for this array for different ground systems and feed-line impedances. The information appears in Table 5. Calculation of actual values of L and C are the same as for the earlier example.

**Table 5**  
**L Network Values for the Four-Element Rectangular Array (Fig 27)**

$R_S$ , $\Omega$	No. of Radials per Element	$Z_0$ , $\Omega$	$X_{SER}$ , $\Omega$	$X_{SH}$ , $\Omega$
65	4	50	14.9	-14.0
65	4	75	33.5	-31.6
54	8	50	17.1	-16.0
54	8	75	38.5	-36.1
34	16	50	19.5	-18.1
34	16	75	43.9	-40.8
36	$\infty$	50	22.7	-20.8
36	$\infty$	75	51.1	-46.9

## THE FOUR-SQUARE ARRAY

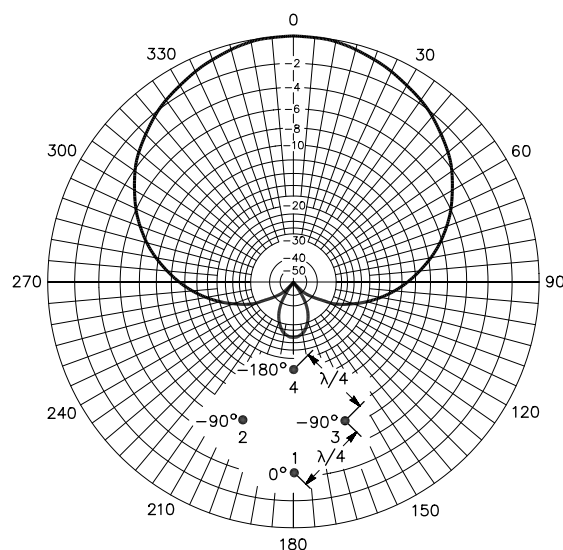
A versatile array is one having four elements arranged in a square, commonly called the *four-square array*. The array layout and its pattern are shown in Fig 28. This array has several attractive properties:

- 1) 5.5 dB forward gain over a single similar element, for any value of loss resistance;
- 2) 3 dB or greater forward gain over a  $90^\circ$  angle;
- 3) 20 dB or better F/B ratio maintained over a  $130^\circ$  angle;
- 4) symmetry that allows directional switching in  $90^\circ$  increments.

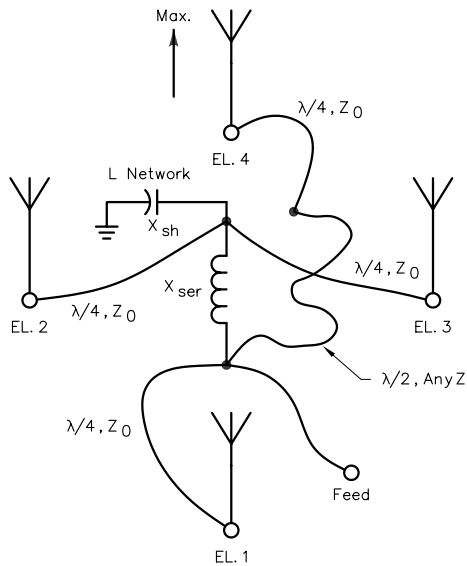
Because of the large differences in element feed-point impedances from mutual coupling, casual feed systems nearly always lead to poor performance of this array. Using the feed system described here, performance is very good, being limited chiefly by environmental factors. Such an array and feed system have been in use at W7EL for several years.

Although the impedances of only two of the four elements need to be calculated to design the feed system, all element impedances will be calculated to show the wide differences in value. This is done by using Eqs 24, 25, 26, 27, 28 and 29, with the following values for the variables.

$$\begin{aligned} M_{jk} &= 1 \text{ for all } j \text{ and } k \\ R_{12} = R_{21} = R_{13} = R_{31} = R_{24} = R_{42} = R_{34} = R_{43} &= 20 \Omega \text{ (from} \\ &\text{Fig 20, } 0.25\text{-}\lambda \text{ spacing)} \\ X_{12} = X_{21} = X_{13} = X_{31} = X_{24} = X_{42} = X_{34} = X_{43} &= -15 \Omega \\ &\text{(} 0.25\text{-}\lambda \text{ spacing)} \\ R_{14} = R_{41} = R_{23} = R_{32} &= 8 \Omega \text{ (} 0.354\text{-}\lambda \text{ spacing)} \\ X_{14} = X_{41} = X_{23} = X_{32} &= -18 \Omega \text{ (} 0.354\text{-}\lambda \text{ spacing)} \\ f_{12} = f_{13} = f_{24} = f_{34} &= -90^\circ \\ f_{21} = f_{31} = f_{42} = f_{43} &= 90^\circ \\ f_{14} = f_{41} &= \pm 180^\circ \\ f_{23} = f_{32} &= 0^\circ \end{aligned}$$



**Fig 28—Pattern and layout of the four-square array. Gain is referenced to a single similar element; add 5.5 dB to the scale values shown.**



**Fig 29—Feed system for the four-square array. Grounds and cable shields have been omitted for clarity.**

resulting in

$$R_1 = R_S - 38 \Omega$$

$$X_1 = X_S - 22 \Omega$$

$$R_2 = R_3 = R_S + 8 \Omega$$

$$X_2 = X_3 = X_S - 18 \Omega$$

$$R_4 = R_S + 22 \Omega$$

$$X_4 = X_S + 58 \Omega$$

where  $R_S$  and  $X_S$  are the resistance and reactance of a single element when isolated from the array.

If element 1 had a perfect ground system and were resonant (a self-impedance of  $36 + j 0 \Omega$ ), in the array it would have a feed-point impedance of  $36 - 38 - j 22 = -2 - j 22 \Omega$ . The negative resistance means that it would be delivering power *into* the feed system. This can, and does, happen in some phased arrays, and is a perfectly legitimate result. The power is, of course, coupled into it from the other elements by mutual coupling. Elements having impedances of precisely zero ohms could have the feed line short circuited at the feed point without effect; that is what a parasitic

**Table 6**

**L Network Values for the Four-Square Array (Fig 29)**

$R_S$ , $\Omega$	No. of Radials per Element	$Z_0$ , $\Omega$	$X_{SER}$ , $\Omega$	$X_{SH}$ , $\Omega$
65	4	50	17.1	-13.7
65	4	75	38.5	-30.9
54	8	50	20.2	-15.6
54	8	75	45.4	-35.2
34	16	50	23.6	-17.6
34	16	75	53.1	-39.6
36	$\infty$	50	28.4	-20.2
36	$\infty$	75	63.9	-45.4

element is. This is yet another illustration of the error of trying to deliver equal *powers* to the elements.

The basic system for properly feeding the four-square array is shown in **Fig 29**. Foamed-dielectric cable must be used for the  $\frac{1}{4}\lambda$  lines. The velocity factor of solid dielectric cable is lower, making an electrical  $\frac{1}{4}\lambda$  of that type physically too short to reach. Elements 2 and 3 are forced to have equal and in-phase currents regardless of differences in ground systems. Likewise, elements 1 and 4 are forced to have equal,  $180^\circ$  out-of-phase currents, in spite of extremely different feed-point impedances. The  $90^\circ$  phasing between element pairs is accomplished, as before, by an L network.

Eqs 44 and 45 may be used directly to generate a table of network element values for this array. For this array the values of resistance and reactance for element 3 are as calculated above.

$$R_3 = R_S + 8 \Omega$$

$$X_3 = X_S - 18 \Omega = -18 \Omega$$

(Because each element was resonated when isolated from the other elements,  $X_S$  equals 0.) **Table 6** shows values of L-network components for various ground systems and feed-line impedances.

This array is more sensitive to adjustment than the two-element  $90^\circ$  fed,  $90^\circ$  spaced array. Adjustment procedures and a method of remotely switching the direction of this array are described in the section that follows.

## Practical Aspects of Phased Array Design

With almost any type of antenna system, there is much that can be learned from experimenting with, testing, and using various array configurations. In this section, Roy Lewallen, W7EL, shares the benefit of years of his experience from actually building, adjusting, and using phased arrays. There is much more work to be done in most of the areas covered here, and Roy encourages the reader to build on this work.

### Adjusting Phased Array Feed Systems

If a phased array is constructed only to achieve forward gain, adjusting it is seldom worthwhile. This is because the forward gain of most arrays is quite insensitive to either the magnitude or phase of the relative currents flowing in the elements. If, however, good rejection of unwanted signals is desired, adjustment may be required.

The in-phase and 180° out-of-phase current-forcing methods supply very well-balanced and well-phased currents to the elements without adjustment. If the pattern of an array fed using this method is unsatisfactory, this is generally the result of environmental differences; the elements, furnished with correct currents, do not generate correct fields. Such an array can be optimized in a single direction, but a more general approach than the current-forcing method must be taken. Some possibilities are described by [Paul Lee](#) and [Forrest Gehrke](#) (see Bibliography).

Unlike the current-forcing methods, the quadrature feed systems described earlier in this chapter are dependent on the element self and mutual impedances. The required L network component values can be computed to a high level of precision, but the results are only as good as the knowledge of the relevant impedances. A practical approach is to estimate the impedances or measure them with moderate accuracy, and adjust the network for the best performance. Simple arrays, such as the two-element 90° fed and spaced array, may be adjusted as follows.

Place a low-power signal source at a distance from the array (preferably several wavelengths), in the direction of the null. While listening to the signal on a receiver connected to the array, alternately adjust the two L-network components for the best rejection of the signal.

This has proved to be a very good way to adjust two-element arrays. However, variable results were obtained when a four-square array was adjusted using this technique. The probable reason is that more than one combination of current balance and phasing will produce a null in a given direction. But the overall array pattern is different for each

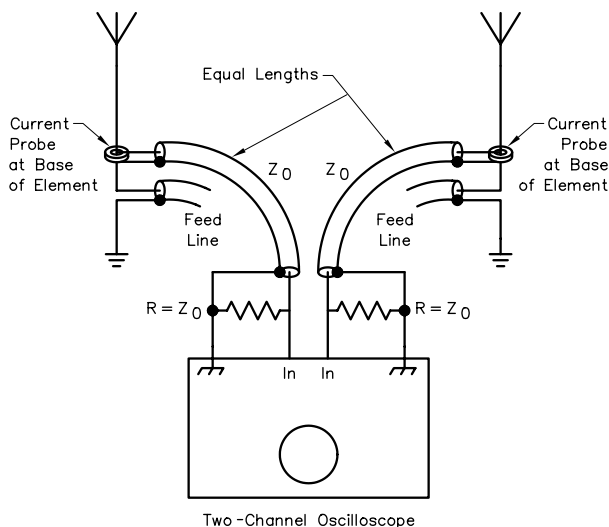
combination. So a different method must be used for adjusting more complex arrays. This involves actually measuring the element currents one way or another, and adjusting the network until the currents are correct.

### MEASURING ELEMENT CURRENTS

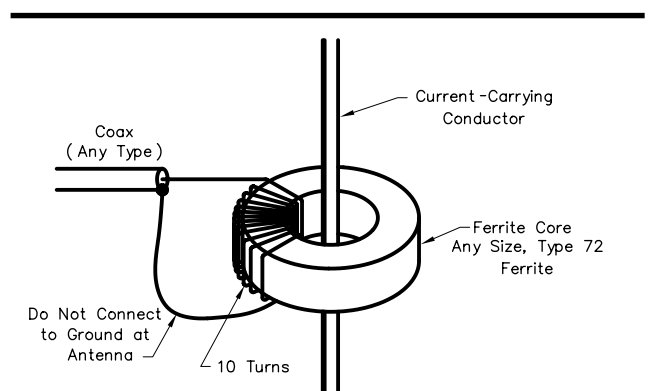
The element currents can be measured two ways. One way is to measure them directly at the element feed points, as shown in [Fig 30](#). A dual-channel oscilloscope is required to monitor the currents. This method is the most accurate, and it provides a direct indication of the actual relative magnitudes and phases of the element currents. The current probe is shown in [Fig 31](#).

Instead of measuring the element currents directly, they may be indirectly monitored by measuring the voltages on the feed lines an electrical  $\frac{1}{4}$  or  $\frac{3}{4}$   $\lambda$  from the array. The voltages at these points are directly proportional to the element currents. All the example arrays presented earlier ([Figs 18, 21, 25, 27](#) and [29](#)) have  $\frac{1}{4}$  or  $\frac{3}{4}$   $\lambda$  lines from all elements to a common location, making this measurement method convenient. The voltages may be observed with a dual-channel oscilloscope, or, to adjust for equal-magnitude currents and 90° phasing, the test circuit shown in [Fig 32](#) may be used.

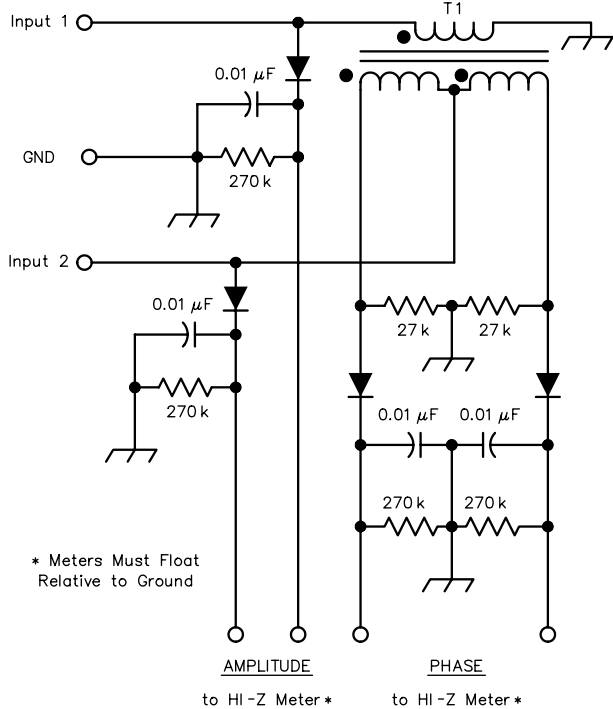
The test circuit is connected to the feed lines of two elements which are to be adjusted for 90° phasing (such as elements 1 and 2, or 2 and 4 of the four-square array of [Fig 29](#)). Adjust the L-network components alternately until both meters read zero. Proper operation of the test circuit may be verified by disconnecting one of the inputs. The *phase* output should then remain close to zero. If not, there is an undesirable imbalance in the circuit, which must be corrected. Another means of verification is to first adjust the L network so the tester indicates correct phasing (zero volts at the *phase* output). Then reverse the tester input connections to the elements. The *phase* output should remain close to zero.



**Fig 30**—One method of measuring element currents in a phased array. Details of the current probe are given in [Fig 31](#). **Caution:** Do not run high power to the antenna system for this measurement, or damage to the test equipment may result.



**Fig 31**—The current probe for use in the test setup of [Fig 30](#). The ferrite core is of type 72 material, and may be any size. The coax line must be terminated at the opposite end with a resistor equal to its characteristic impedance.

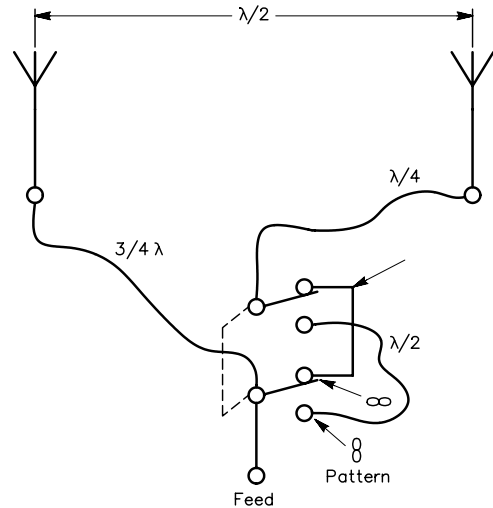


**Fig 32—Quadrature test circuit.** All diodes are germanium, such as 1N34A, 1N270, or equiv. All resistors are 1/4 or 1/2 W, 5% tolerance. Capacitors are ceramic. Alligator clips are convenient for making the input and ground connections to the array. T1—7 trifilar turns on an Amidon FT-37-72 or equiv ferrite toroid core.

### DIRECTIONAL SWITCHING OF ARRAYS

One ideal directional-switching method would take the entire feed system, including the lines to the elements, and rotate them. The smallest possible increment of rotation depends on the symmetry of the array—the feed system would need to rotate until the array again *looks* the same to it. For example, any two-element array can be rotated 180° (although that wouldn't accomplish anything if the array was bidirectional to begin with). The four-element rectangular array of Figs 26 and 27 can also be reversed, and the four-square array of Figs 28 and 29 can be switched in 90° increments. Smaller increment switching can be accomplished only by reconfiguring the feed system, including the phase shift network, if used. Switching in smaller increments than dictated by symmetry will create a different pattern in some directions than in others, and must be thoughtfully done to maintain equal and properly phased element currents. The methods illustrated here will deal only with switching in increments related to the array symmetry, except one, a two-element broadside/end-fire array.

In arrays containing quadrature-fed elements, the success of directional switching depends on the elements and ground systems being identical. Few of us can afford the luxury of having an array many wavelengths away from



**Fig 33—Two-element broadside/end-fire switching.** All lines must have the same characteristic impedance. Grounds and cable shields have been omitted for clarity.

all other conductors, so an array will nearly always perform somewhat differently in each direction. The array, then, should be adjusted when steered in the direction requiring the most signal rejection in the nulls. Forward gain will, for practical purposes, be equal in all the switched directions, since gain is much more tolerant of error than nulls are.

### BASIC SWITCHING METHODS

Following is a discussion of basic switching methods, how to power relays through the main feed line, and other practical considerations. In diagrams, grounds are frequently omitted to aid clarity, but connections of the ground conductors must be carefully made. In fact, it is recommended that the ground conductors be switched just as the center conductors are. This is explained in more detail in subsequent text. In all cases, interconnecting lines must be very short.

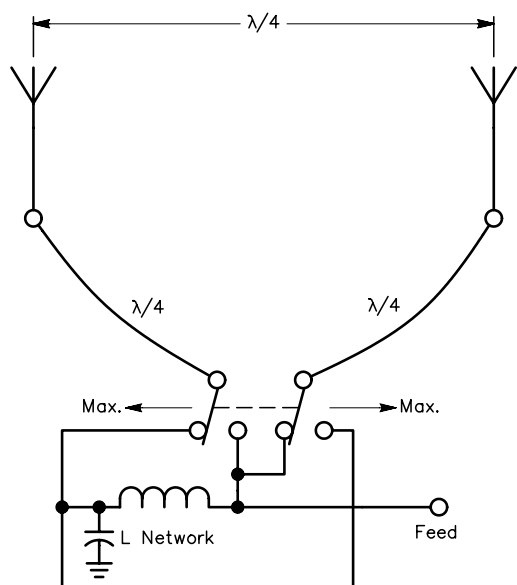
A pair of elements spaced 1/2 λ apart can readily be switched between broadside and end-fire bidirectional patterns, using the current-forcing properties of 1/4-λ lines. The method is shown in Fig 33. The switching device can be a relay powered via a separate cable or by dc sent along the main feed line.

Fig 34 shows directional switching of a 90° fed, 90° spaced array. The rectangular array of Figs 26 and 27 can be switched in a similar manner, as shown in Fig 35.

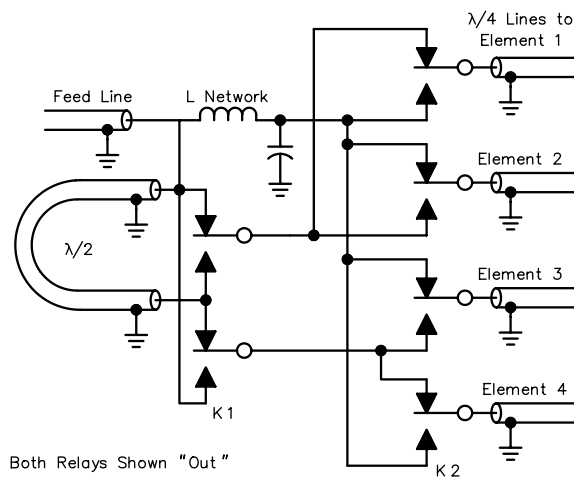
Switching the direction of an array in increments of 90°, when permitted by its symmetry, requires at least two relays. A method of 90° switching of the four-square array is shown in Fig 36.

### Powering Relays Through Feed Lines

All of the above switching methods can be implemented without additional wires to the switch box. A single-relay system is shown in Fig 37A, and a two-relay system in



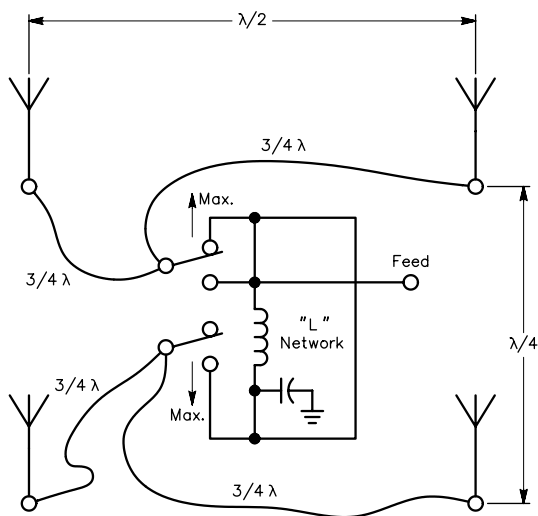
**Fig 34—90° fed, 90° phased array reversal switching. All interconnections must be very short. Grounds and cable shields have been omitted for clarity.**



Both Relays Shown "Out"

Element No.	Pattern Maximum in Direction of Element No.	Relays K1	Relays K2
El. 4	1	In	Out
El. 2	2	In	In
El. 3	3	Out	In
El. 1	4	Out	Out

**Fig 36—Directional switching of the four-square array. All interconnections must be very short.**



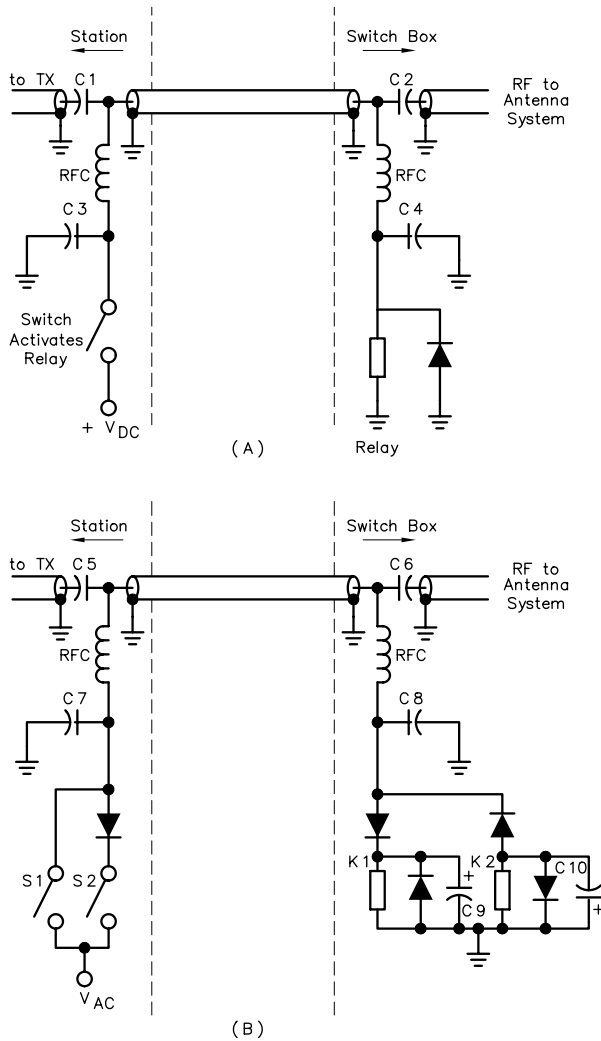
**Fig 35—Directional switching of a four-element rectangular array. All interconnections must be very short. Grounds and cable shields have been omitted for clarity.**

**Fig 37B.** Small 12 or 24-V dc power relays can be used in either system at power levels up to at least a few hundred watts. Do not attempt to change directions while transmitting, however. Blocking capacitors C1 and C2 should be good quality ceramic or transmitting mica units of 0.01 to 0.1 μF. No problems have been encountered using 0.1 μF, 300-V monolithic ceramic units at RF output levels up to 300 W. C2 may be omitted if the antenna system is an open circuit at dc. C3 and C4 should be ceramic, 0.001 μF or larger.

In **Fig 37B**, capacitors C5 through C8 should be selected with the ratings of their counterparts in **Fig 36A**, as given above. Electrolytic capacitors across the relay coils, C9 and C10 in **Fig 37B**, should be large enough to prevent the relays from buzzing, but not so large as to make relay operation too slow. Final values for most relays will be in the range from 10 to 100 μF. They should have a voltage rating of at least double the relay coil voltage. Some relays do not require this capacitor. All diodes are 1N4001 or similar. A rotary switch may be used in place of the two toggle switches in the two-relay system to switch the relays in the desired sequence.

Although plastic food-storage boxes are inexpensive and durable, using them to contain the direction-switching circuitry might lead to serious phasing errors. If the circuitry is implemented as shown in **Figs 33, 34, 35** and **36** and the feed-line grounds are simply connected together, the currents from more than one element share a single conductive path and get phase shifted by the reactance of the wire. As much as 30° of phase shift has been measured at 7 MHz from one side of a plastic box to the other, a distance of only four inches! #12 wire was connecting the two points. Since this experience, twice the number of relay contacts have been used, and the ground conductor of each coaxial cable has been switched right along with the center conductor. A solid metal box might present a path of low enough impedance to prevent the problem. If it does not, the best solution is to use a nonconductive box, and switch the grounds as described.



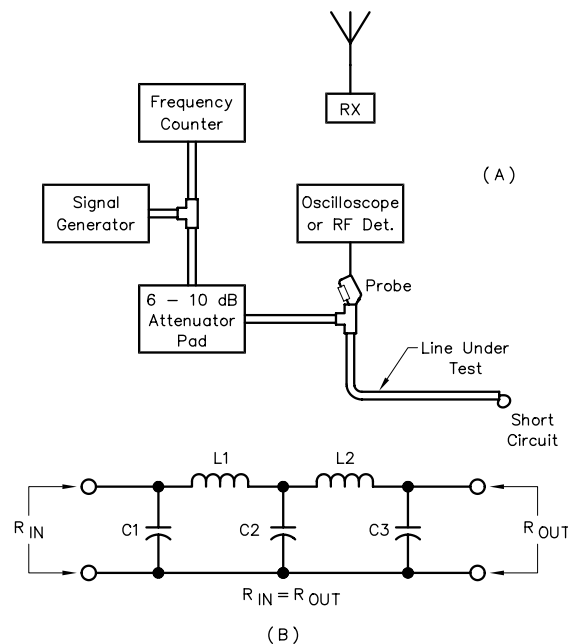


**Fig 37—Remote switching of relays.** See text for component information. A one-relay system is shown at A, and a two-relay system at B. In B, S1 activates K1, and S2 activates K2.

### MEASURING THE ELECTRICAL LENGTH OF FEED LINES

When using the feed methods described earlier, the feed lines must be very close to the correct length. For best results, they should be correct within 1% or so. This means that a line that is intended to be, say,  $\frac{1}{4} \lambda$  at 7 MHz, should actually be  $\frac{1}{4} \lambda$  at some frequency within 70 kHz of 7 MHz. A simple but accurate method to determine at what frequency a line is  $\frac{1}{4}$  or  $\frac{1}{2} \lambda$  is shown in Fig 38A. The far end of the line is short circuited with a very short connection. A signal is applied to the input, and the frequency is swept until the impedance at the input is a minimum. This is the frequency at which the line is  $\frac{1}{2} \lambda$ . Either the frequency counter or the receiver may be used to determine this frequency. The line is, of course,  $\frac{1}{4} \lambda$  at one half the measured frequency.

The detector can be a simple diode detector, or an oscilloscope may be used if available. A 6 to 10 dB attenuator



**Fig 38—At A, the setup for measurement of the electrical length of a transmission line.** The receiver may be used in place of the frequency counter to determine the frequency of the signal generator. The signal generator output must be free of harmonics; the half-wave harmonic filter at B may be used outboard if there is any doubt. It must be constructed for the frequency band of operation. Connect the filter between the signal generator and the attenuator pad.

C1, C3—Value to have a capacitive reactance =  $R_{IN}$ .  
 C2—Value to have a capacitive reactance =  $\frac{1}{2} R_{IN}$ .  
 L1, L2—Value to have an inductive reactance =  $R_{IN}$ .

pad is included to prevent the signal generator from looking into a short circuit at the measurement frequency. The signal generator output must be free of harmonics. If there is any doubt, an outboard low-pass filter, such as a half-wave harmonic filter, should be used. The half-wave filter circuit is shown in Fig 38B, and must be constructed for the frequency band of operation.

Another satisfactory method is to use a noise or resistance bridge at the input of the line, again looking for a low impedance at the input while the output is short circuited. Simple resistance bridges are described in Chapter 27.

Dip oscillators have been found to be unsatisfactory. The required coupling loop has too great an effect on measurements.

### MEASURING ELEMENT SELF-IMPEDANCE

The self-impedance of an unbalanced element, such as a vertical monopole, can be measured directly at the feed point using an impedance bridge. Commercial noise bridges are available, and noise and RLC bridges for home construction are described in Chapter 27. In the 1990s, portable impedance/SWR-measuring instruments with built-in signal generators and digital readouts have become very popular.

When the measurement is being made, all other elements must be *open circuited*. If the feed point is not readily accessible, the impedance can be measured remotely through one or more half wavelengths of transmission line. Other line lengths may also be used, but then an impedance conversion becomes necessary, such as with a Smith Chart (see [Chapter 28](#)) or by using a computer program, such as the *TLW* program on the CD-ROM included with this book.

A balanced antenna, for example a dipole, must be measured through a transmission line to permit insertion of the proper type of balun (see below) unless the impedance meter can be effectively isolated from the ground and nearby objects, including the person doing the measurement. When measuring impedance through a transmission line, the following precautions must be taken to avoid substantial errors.

- 1) The characteristic impedance of the transmission line should be as close as possible to the impedance being measured. The closer the impedances, the less the sensitivity to feed-line loss and length.
- 2) Do not use any more  $1/2\text{-}\lambda$  sections of line than necessary. Errors are multiplied by the number of sections. Measurements made through lines longer than  $1\ \lambda$  should be suspect.
- 3) Use low-loss line. Lossy line will skew the measured value toward the characteristic impedance of the line. If the line impedance is close to the impedance being measured, the effect is usually negligible.
- 4) If a  $1/2\text{-}\lambda$  section of line or multiple is being used, measure the line length using one of the methods described earlier. Do not try to make measurements at frequencies very far away from the frequency at which the line is the correct length. The sensitivity to electrical line length is less if the line impedance is close to the impedance being measured.
- 5) If the impedance of a balanced antenna such as a dipole is being measured, the correct type of balun must be used. (See [Lewallen](#) on baluns, listed in the Bibliography.) One way to make the proper type of balun is to use coaxial feed line, and pass the line through a large, high permeability ferrite core several times, near the antenna. Or a portion of the line may be wound into a flat coil of several turns, a foot or two in diameter, near the antenna. A third method is to string a large number of ferrite cores over the feed line, as described in [Chapter 26](#). The effectiveness of the balun can be tested by watching the impedance measurement while moving the coax about, and grasping it and letting go. The measurement should not change when this is done.

### MEASURING MUTUAL IMPEDANCE

Various methods for determining the mutual impedance between elements have been devised. Each method has advantages and disadvantages. The basic difficulty in achieving accuracy is that the measurement of a small change in a large value is required. Two methods are described here.

Both require the use of a calibrated impedance bridge. The necessary calculations require a knowledge of complex arithmetic. If measurements are made through feed lines, instead of directly at the feed points, the precautions listed above must be observed.

#### Method 1

- 1) Measure the self-impedance of one element with the second element open circuited at the feed point, or with the second element connected to an open-circuited feed line that is an integral number of  $1/2\ \lambda$  long. This impedance is designated  $Z_{11}$ .
- 2) Measure the self-impedance of the second element with the first element open circuited. This impedance is called  $Z_{22}$ .
- 3) Short circuit the feed point of the second element, directly or at the end of an integral number of  $1/2\ \lambda$  of feed line. Measure the impedance of the first element. This is called  $Z_{1S}$ .
- 4) Calculate the mutual impedance  $Z_{12}$ .

$$Z_{12} = \pm \sqrt{Z_{22}(Z_{11} - Z_{1S})} \quad (\text{Eq 46})$$

where all values are complex.

Because the square root is extracted, there are two answers to this equation. One of these answers is correct and one is incorrect. There is no way to be sure which answer is correct except by noticing which one is closest to a theoretical value, or by making another measurement with a different method. This ambiguity is one disadvantage of using method 1. The other disadvantage is that the difference between the two measured values is small unless the elements are very closely spaced. This can cause relatively large errors in the calculated value of  $Z_{12}$  if small errors are made in the measured impedances. Useful results can be obtained with this method if care is taken, however. The chief advantage of method 1 is its simplicity.

#### Method 2

- 1) As in method 1, begin by measuring the self-impedance of one element, with the second element open circuited at the feed point, or with the second element connected to a  $1/2\text{-}\lambda$  (or multiple) open-circuited line. Designate this impedance  $Z_{11}$ .
- 2) Measure the self-impedance of the second element with the first element open circuited. Call this impedance  $Z_{22}$ .
- 3) Connect the two elements together with  $1/2\ \lambda$  of transmission line, and measure the impedance at the feed point of one element. A  $1/2\text{-}\lambda$  line may be added to both elements for this measurement if necessary. That is, the line to element 1 would be  $1/2\ \lambda$ , and the line to element 2 a full wavelength. Be sure to read and observe the precautions necessary when measuring impedance through a transmission line, enumerated earlier. This measured impedance is called  $Z_{1X}$ .
- 4) Calculate the mutual impedance  $Z_{12}$ .

$$Z_{12} = Z_{21} = -Z_{1X} \pm \sqrt{(Z_{1X} - Z_{11})(Z_{1X} - Z_{22})} \quad (\text{Eq 47})$$

where all values are complex.

Again, there are two answers. But the correct one is generally easier to identify than when method 1 is used. For most systems,  $Z_{11}$  and  $Z_{22}$  are about the same. If they are, the wrong answer will be about equal to  $-Z_{11}$  (or  $-Z_{22}$ ). The correct answer will be about equal to  $Z_{11} - 2Z_{1X}$  (or  $Z_{22} - 2Z_{1X}$ ). The advantages of this method are that the correct answer is easier to identify, and that there is a larger difference between the two measured impedances. The

disadvantage is that the  $\frac{1}{2}\lambda$  line adds another possible source of error.

The wrong answers from methods 1 and 2 will be different, but the correct answers should be the same. Measure with both methods, if possible. Accuracy in these measurements will enable the builder to determine more precisely the proper values of components for a phasing L network. And with precision in these measurements, the performance features of the array, such as gain and null depth, can be determined more accurately with methods given earlier in this chapter.

## Broadside Arrays

Broadside arrays can be made up of collinear or parallel elements or combinations of the two. This section was contributed by Rudy Severns, N6LF.

### COLLINEAR ARRAYS

Collinear arrays are always operated with the elements in phase. (If alternate elements in such an array are out of phase, the system simply becomes a harmonic type of antenna.) A collinear array is a broadside radiator, the direction of maximum radiation being at right angles to the line of the antenna.

### POWER GAIN

Because of the nature of the mutual impedance between collinear elements, the feed-point resistance (compared to a single element, which is  $\approx 73 \Omega$ ) is increased as shown earlier in this chapter (Fig 9). For this reason the power gain does not increase in direct proportion to the number of elements. The gain with two elements, as the spacing between them is varied, is shown by Fig 39. Although the gain is greatest when the end-to-end spacing is in the region of  $0.4$  to  $0.6 \lambda$ , the use of spacings of this order is inconvenient constructionally and introduces problems in feeding the two elements. As a result, collinear elements are almost always operated with their ends quite close together—in wire antennas, usually with just a strain insulator between.

With very small spacing between the ends of adjacent elements the theoretical power gain of collinear arrays, assuming the use of #12 copper wire, is approximately as follows:

- 2 collinear elements—1.6 dB
- 3 collinear elements—3.1 dB
- 4 collinear elements—3.9 dB
- More than four elements are rarely used.

### DIRECTIVITY

The directivity of a collinear array, in a plane containing the axis of the array, increases with its length. Small secondary lobes appear in the pattern when more than two elements are used, but the amplitudes of these lobes are low enough so that they are usually not important. In a plane at right angles to the array the directive diagram is a circle, no matter what the number of elements. Collinear operation,

therefore, affects only E-plane directivity, the plane containing the antenna.

When a collinear array is mounted with the elements vertical, the antenna radiates equally well in all geographical directions. An array of such *stacked* collinear elements tends to confine the radiation to low vertical angles.

If a collinear array is mounted horizontally, the directive pattern in the vertical plane at right angles to the array is the same as the vertical pattern of a simple  $\lambda/2$  antenna at the same height (Chapter 3).

### TWO-ELEMENT ARRAYS

The simplest and most popular collinear array is one using two elements, as shown in Fig 40. This system is commonly known as *two half-waves in phase*. The directive pattern in a plane containing the wire axis is shown in Fig 41. Fig 41 gives superimposed patterns for a dipole and 2, 3 and 4 element collinear arrays. Depending on the conductor size, height, and similar factors, the impedance at the feed point can be expected to be in the range of 4 to 6 k $\Omega$ , for wire antennas. If the elements are made of tubing having a low  $\lambda/\text{dia}$  (wavelength to diameter) ratio, values as low as 1 k $\Omega$  are representative. The system can be fed through an open-

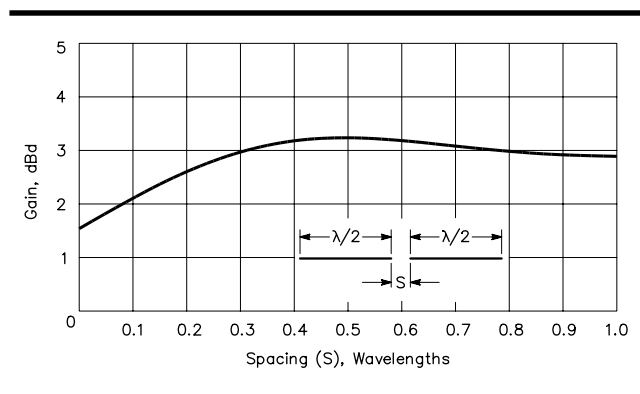
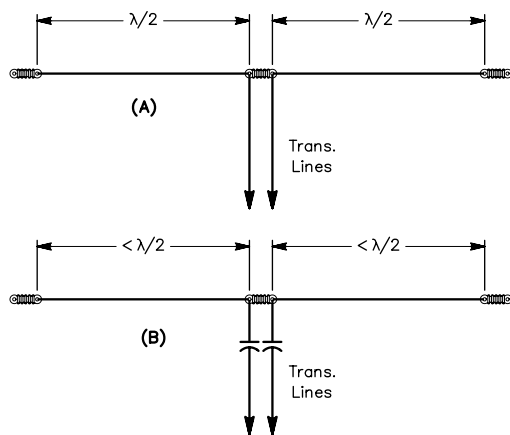
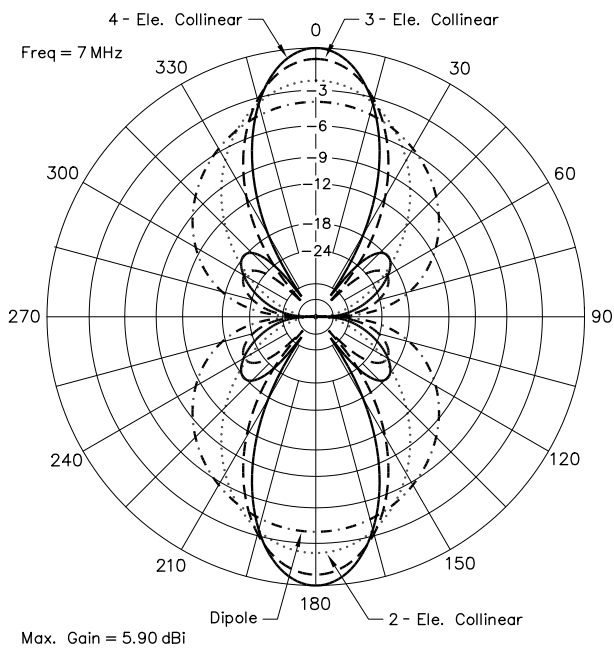


Fig 39—Gain of two collinear  $\frac{1}{2}\lambda$  elements as a function of spacing between the adjacent ends.



**Fig 40—At A, two-element collinear array (two half-waves in phase). The transmission line shown would operate as a tuned line. A matching section can be substituted and a nonresonant line used if desired, as shown at B, where the matching section is two series capacitors.**



**Fig 41—Free-space E-plane directive diagram for dipole, 2, 3 and 4-element collinear arrays. The solid line is a 4-element collinear; the dashed line is for a 3-element collinear; the dotted line is for a 2-element collinear and the dashed-dotted line is for a  $\lambda/2$  dipole.**

wire tuned line with negligible loss for ordinary line lengths, or a matching section may be used if desired.

A number of arrangements for matching the feedline to this antenna are described in [Chapter 26](#). If elements somewhat shorter than  $\lambda/2$  are used, then additional matching schemes can be employed at the expense of a slight reduction

in gain. When the elements are shortened two things happen—the impedance at the feed-point drops and the impedance has inductive reactance that can be tuned out with simple series capacitors, as shown in Fig 40B.

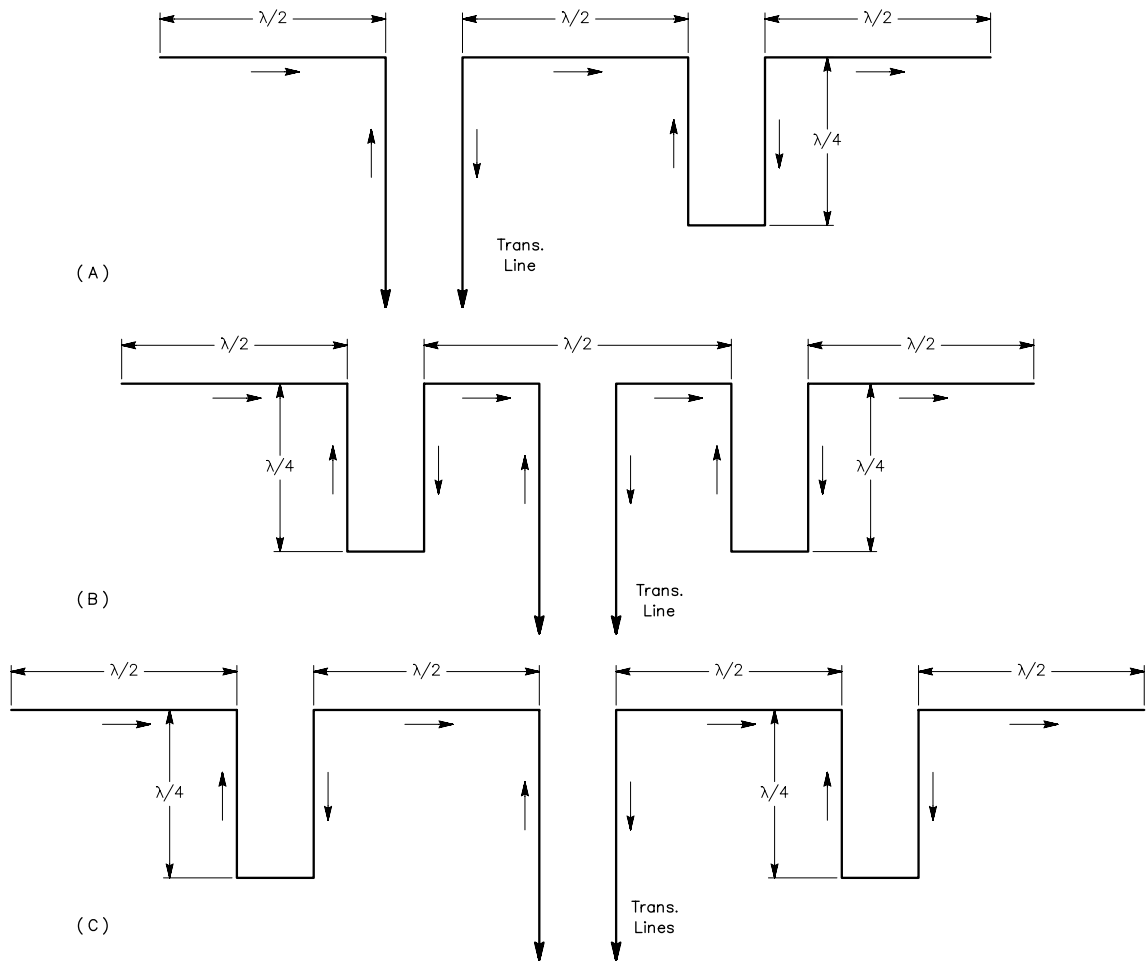
Note that these capacitors must be suitable for the power level. Small *doorknob* capacitors such as those frequently used in power amplifiers, are suitable. By way of an example, if each side of a 40-meter 2-element array is shortened from 67 to 58 feet, the feed-point impedance drops from nearly 6000  $\Omega$  to about 1012  $\Omega$  with an inductive reactance of 1800  $\Omega$ . The reactance can be tuned out by inserting 25 pF capacitors at the feed-point. The 1012  $\Omega$  resistance can be transformed to 200  $\Omega$  using a  $\lambda/4$  matching section made of 450- $\Omega$  ladder line and then transformed to 50  $\Omega$  with a 4:1 balun. Shortening the array as suggested reduces the gain by about 0.5 dB.

Another scheme that preserves the gain is to use a 450- $\Omega$   $\lambda/4$  matching section and shorten the antenna only slightly to have a resistance of 4 k $\Omega$ . The impedance at the input of the matching section is then near 50  $\Omega$  and a simple 1:1 balun can be used. Many other schemes are possible. The free-space E-plane response for a 2-element collinear array is shown in Fig 41, compared with the responses for more elaborate collinear arrays described below.

### THREE- AND FOUR-ELEMENT ARRAYS

In a long wire the direction of current flow reverses in each  $\lambda/2$  section. Consequently, collinear elements cannot simply be connected end to end; there must be some means for making the current flow in the same direction in all elements. When more than two collinear elements are used it is necessary to connect *phasing* stubs between adjacent elements in order to bring the currents in all elements in phase. In Fig 42A the direction of current flow is correct in the two left-hand elements because the shorted  $\lambda/4$  transmission line (*stub*) is connected between them. This stub may be looked upon simply as the alternate  $\lambda/2$  section of a long-wire antenna folded back on itself to cancel its radiation. In Fig 42A the part to the right of the transmission line has a total length of three half wavelengths, the center half wave being folded back to form a  $\lambda/4$  phase-reversing stub. No data are available on the impedance at the feed point in this arrangement, but various considerations indicate that it should be over 1 k $\Omega$ .

An alternative method of feeding three collinear elements is shown in Fig 42B. In this case power is applied at the center of the middle element and phase-reversing stubs are used between this element and both of the outer elements. The impedance at the feed point in this case is somewhat over 300  $\Omega$  and provides a close match to 300  $\Omega$  line. The SWR will be less than 2:1 when 600- $\Omega$  line is used. Center feed of this type is somewhat preferable to the arrangement in Fig 42A because the system as a whole is balanced. This assures more uniform power distribution among the elements. In Fig 42A, the right-hand element is likely to receive somewhat less power than the other two because a



**Fig 42—Layouts for 3- and 4-element collinear arrays. Alternative methods of feeding a 3-element array are shown at A and B. These drawings also show the current distribution on the antenna elements and phasing stubs. A matched transmission line can be substituted for the tuned line by using a suitable matching section.**

portion of the input power is radiated by the middle element before it can reach the element located at the extreme right.

A four-element array is shown in Fig 42C. The system is symmetrical when fed between the two center elements as shown. As in the three-element case, no data are available on the impedance at the feed point. However, the SWR with a 600 Ω line should not be much over 2:1.

Fig 41 compares the directive patterns of 2, 3 and 4-element arrays. Collinear arrays can be extended to more than four elements. However, the simple two-element collinear array is the type most frequently used, as it lends itself well to multi-band operation. More than two collinear elements are seldom used because more gain can be obtained from other types of arrays.

### ADJUSTMENT

In any of the collinear systems described, the lengths of the radiating elements in feet can be found from the formula  $468/f_{\text{MHz}}$ . The lengths of the phasing stubs can be

found from the equations given in Chapter 26 for the type of line used. If the stub is open-wire line (500 to 600 Ω impedance) you may assume a velocity factor of 0.975 in the formula for a  $\lambda/4$  line. On-site adjustment is, in general, an unnecessary refinement. If desired, however, the following procedure may be used when the system has more than two elements.

Disconnect all stubs and all elements except those directly connected to the transmission line (in the case of feed such as is shown in Fig 42B leave only the center element connected to the line). Adjust the elements to resonance, using the still-connected element. When the proper length is determined, cut all other elements to the same length. Make the phasing stubs slightly long and use a shorting bar to adjust their length. Connect the elements to the stubs and adjust the stubs to resonance, as indicated by maximum current in the shorting bars or by the SWR on the transmission line. If more than three or four elements are used it is best to add elements two at a time (one at each end

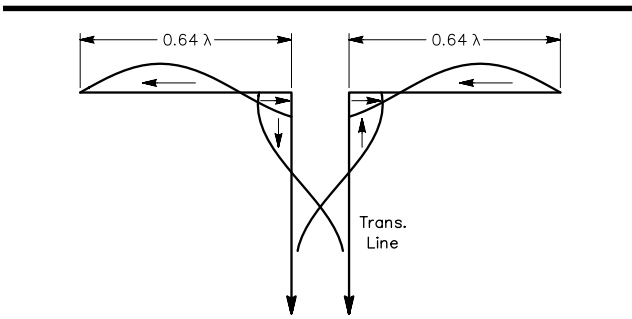
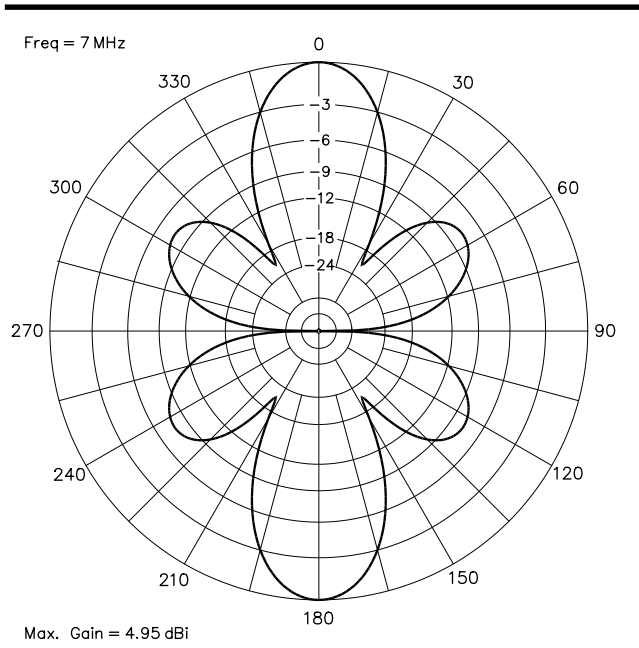
of the array), resonating the system each time before a new pair is added.

### THE EXTENDED DOUBLE ZEPP

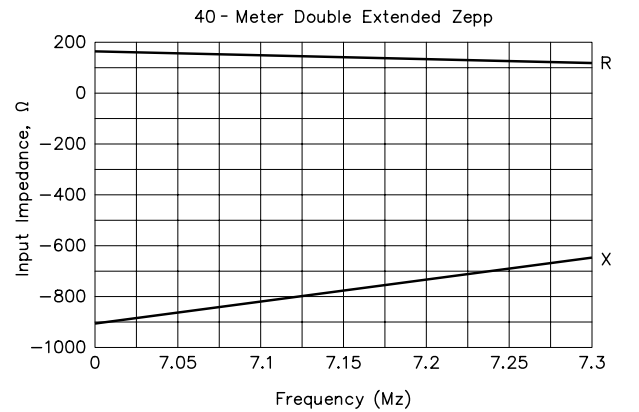
One method to obtain higher gain that goes with wider spacing in a simple system of two collinear elements is to make the elements somewhat longer than  $\lambda/2$ . As shown in **Fig 43**, this increases the spacing between the two in-phase  $\lambda/2$  sections at the ends of the wires. The section in the center carries a current of opposite phase, but if this section is short the current will be small; it represents only the outer ends of a  $\lambda/2$  antenna section. Because of the small current and short length, the radiation from the center is small. The optimum length for each element is  $0.64 \lambda$ . At greater lengths the system tends to act as a long-wire antenna, and the gain decreases.

This system is known as the *extended double Zepp*. The gain over a  $\lambda/2$  dipole is approximately 3 dB, as compared with about 1.6 dB for two collinear  $\lambda/2$  dipoles. The directional pattern in the plane containing the axis of the antenna is shown in **Fig 44**. As in the case of all other collinear arrays, the free-space pattern in the plane at right angles to the antenna elements is the same as that of a  $\lambda/2$  antenna—circular.

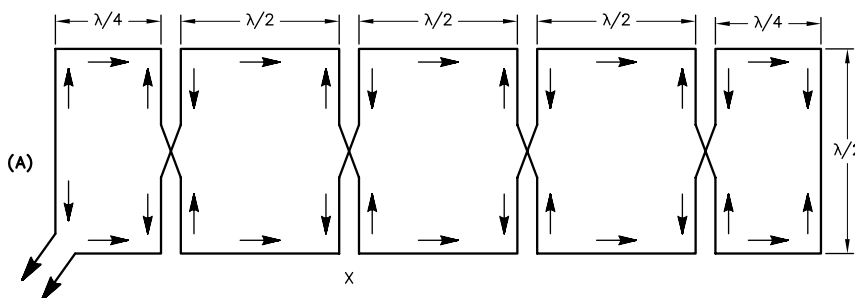
This antenna is not resonant at the operating frequency so that the feed-point impedance is complex ( $R \pm j X$ ). A



**Fig 43**—The extended double Zepp. This system gives somewhat more gain than two  $\lambda$ -sized collinear elements.



**Fig 45**—Resistive and reactive feed-point impedance of a 40-meter extended double Zepp in free space.



**Fig 46**—Typical Sterba array, a 10-element version.

typical example of the variation of the feed-point impedance over the band for a 40-meter double-extended Zepp is shown in Fig 45. This antenna is normally fed with open-wire transmission line to an antenna tuner. Other matching arrangements are, of course, possible. A method for transforming the feed-point impedance to 450 Ω and eliminating the minor lobes is given in Chapter 6.

### THE STERBA ARRAY

Two collinear arrays can be combined to form the *Sterba array*, often called the *Sterba curtain*. An 8-element example of a Sterba array is shown in Fig 46. The four λ/4 elements joined on the ends are equivalent to two λ/2 elements. The two collinear arrays are spaced λ/2 and the λ/4 phasing lines connected together to provide λ/2 phasing lines. This arrangement has the advantage of increasing the gain for a given length and also increasing the E-plane

directivity, which is no longer circular. An additional advantage of this array is that the wire forms a closed loop. For installations where icing is a problem a low voltage dc or low frequency (50 or 60 Hz) ac current can be passed through the wire to heat it for deicing. The heating current is isolated from RF by decoupling chokes. This is standard practice in commercial installations.

The number of sections in a Sterba array can be extended as far as desired but more than four or five are rarely used because of the slow increase in gain with extra elements, the narrow H-plane directivity and the appearance of multiple sidelobes. When fed at the point indicated the impedance is about 600 Ω. The antenna can also be fed at the point marked X. The impedance at this point will be about 1 kΩ. The gain of the 8-element array in Fig 46 will be between 7 to 8 dB over a single element.

## Parallel Broadside Arrays

To obtain broadside directivity with parallel elements the currents in the elements must all be in phase. At a distant point lying on a line perpendicular to the axis of the array and also perpendicular to the plane containing the elements, the fields from all elements add up in phase. The situation is like that pictured in Fig 1 in this chapter, where four parallel 1/2-λ dipoles were fed together a broadside array.

Broadside arrays of this type theoretically can have any number of elements. However, practical limitations of construction and available space usually limit the number of broadside parallel elements.

### POWER GAIN

The power gain of a parallel-element broadside array depends on the spacing between elements as well as on the number of elements. The way in which the gain of a two-element array varies with spacing is shown in Fig 47. The greatest gain is obtained when the spacing is in the vicinity of 0.67 λ.

The theoretical gains of broadside arrays having more than two elements are approximately as follows:

No. of Parallel Elements	dB Gain with λ/2 Spacing	dB Gain with 3/4 λ Spacing
3	5.7	7.2
4	7.1	8.5
5	8.1	9.4
6	8.9	10.4

The elements must, of course, all lie in the same plane and all must be fed in phase.

### DIRECTIVITY

The sharpness of the directive pattern depends on spacing between elements and number of elements. Larger element spacing will sharpen the main lobe, for a given number of elements, up to a point as was shown in Fig 39. The two-element array has no minor lobes when the spacing is λ/2, but small minor lobes appear at greater spacings. When three or more elements are used the pattern always has minor lobes.

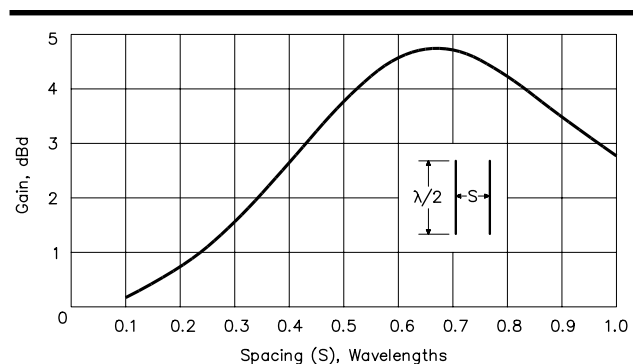


Fig 47—Gain as a function of the spacing between two parallel elements operated in phase (broadside).

# Other Forms Of Broadside Arrays

For those who have the available room, multi-element arrays based on the broadside concept have something to offer. The antennas are large but of simple design and non-critical dimensions; they are also very economical in terms of gain per unit of cost.

Large arrays can often be fed at several different points. However, the pattern symmetry may be sensitive to the choice of feed-point within the array. Non-symmetrical feed points will result in small asymmetries in the pattern but these are not usually of great concern.

Arrays of three and four elements are shown in **Fig 48**. In the 3-element array with  $\lambda/2$  spacing at A, the array is fed at the center. This is the most desirable point in that it tends to keep the power distribution among the elements uniform. However, the transmission line could alternatively be connected at either point B or C of Fig 48A, with only slight skewing of the radiation pattern.

When the spacing is greater than  $\lambda/2$ , the phasing lines must be  $1 \lambda$  long and are not transposed between elements. This is shown Fig 48B. With this arrangement, any element spacing up to  $1 \lambda$  can be used, if the phasing lines can be folded as suggested in the drawing.

The 4-element array at C is fed at the center of the system to make the power distribution among elements as uniform as possible. However, the transmission line could be connected at either point B, C, D or E. In this case the section of phasing line between B and D must be transposed to make the currents flow in the same direction in all elements. The 4-element array at C and the 3-element array at B have approximately the same gain when the element spacing in the array at B is  $3/4 \lambda$ .

An alternative feeding method is shown in Fig 48D. This system can also be applied to the 3-element arrays, and will result in better symmetry in any case. It is necessary only to move the phasing line to the center of each element, making connection to both sides of the line instead of one only.

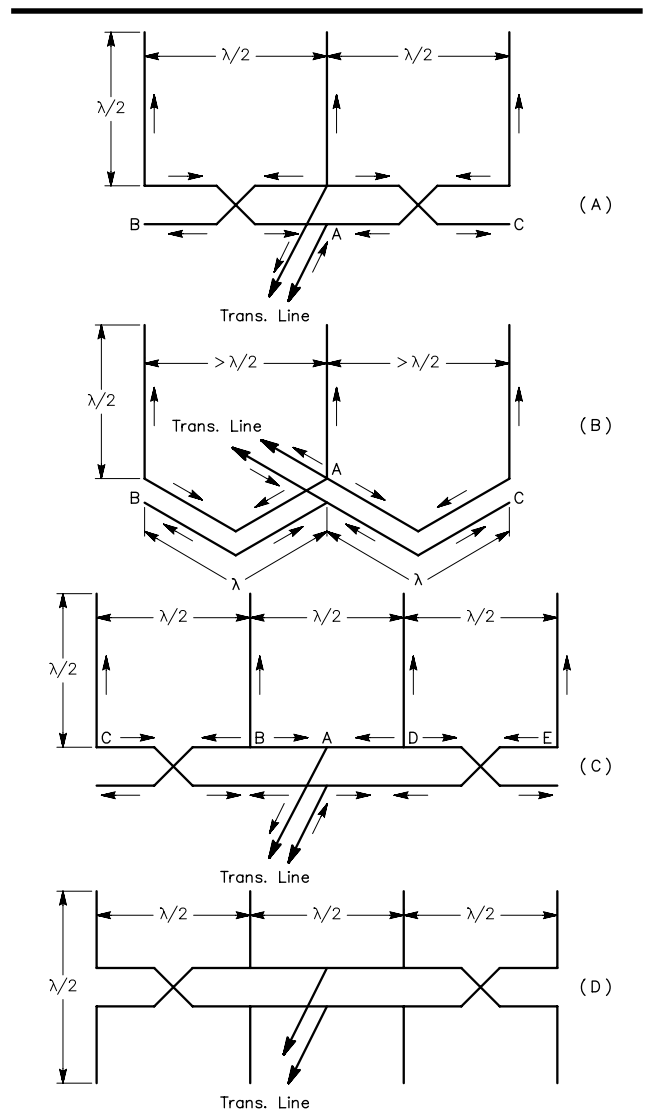
The free-space pattern for a 4-element array with  $\lambda/2$  spacing is shown in **Fig 49**. This is also approximately the pattern for a 3-element array with  $3/4 \lambda$  spacing.

Larger arrays can be designed and constructed by following the phasing principles shown in the drawings. No accurate figures are available for the impedances at the various feed points indicated in Fig 48. You can estimate it to be in the vicinity of  $1 \text{ k}\Omega$  when the feed point is at a junction between the phasing line and a  $\lambda/2$  element, becoming smaller as the number of elements in the array is increased. When the feed point is midway between end-fed elements as in Fig 48C, the feed-point impedance of a 4-element array is in the vicinity of  $200$  to  $300 \Omega$ , with  $600 \Omega$  open-wire phasing lines. The impedance at the feed point with the antenna shown at D should be about  $1.5 \text{ k}\Omega$ .

## NON-UNIFORM ELEMENT CURRENTS

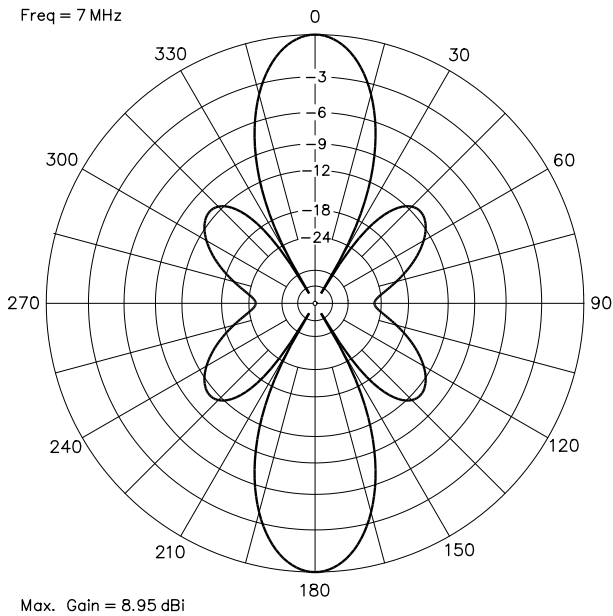
The pattern for a 4-element broadside array shown in

**Fig 49** has substantial side lobes. This is typical for arrays more than  $\lambda/2$  wide when equal currents flow in each element. Sidelobe amplitude can be reduced by using non-uniform current distribution among the elements. Many possible current amplitude distributions have been suggested. All of them have reduced current in the outer elements and greater current in the inner elements. This reduces the gain somewhat but can produce a more desirable pattern. One of the common current distributions is called *binomial current grading*. In this scheme the ratio of element currents is set equal to the coefficients of a polynomial. For example:



**Fig 48—Methods of feeding three- and four-element broadside arrays with parallel elements.**





**Fig 49—Free-space E-plane pattern of a four-element broadside array using parallel elements (Fig 48). This corresponds to the horizontal directive pattern at low wave angles for a vertically polarized array over ground. The axis of the elements lies along the 90°-270° line.**

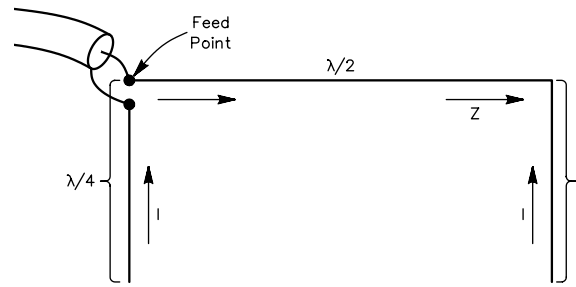
$$\begin{aligned}
 (x + 1) &\Rightarrow 1x + 1 \Rightarrow 1,1 \\
 (x + 1)^2 &= 1x^2 + 2x + 1, \Rightarrow 1,2,1 \\
 (x + 1)^3 &= 1x^3 + 3x^2 + 3x + 1, \Rightarrow 1,3,3,1 \\
 (x + 1)^4 &= 1x^4 + 4x^3 + 6x^2 + 6x + 1, \Rightarrow 1,4,6,4,1
 \end{aligned}
 \tag{Eq 48}$$

In a 2-element array the currents are equal, in a 3-element array the current in the center element is twice that in the outer elements, and so on.

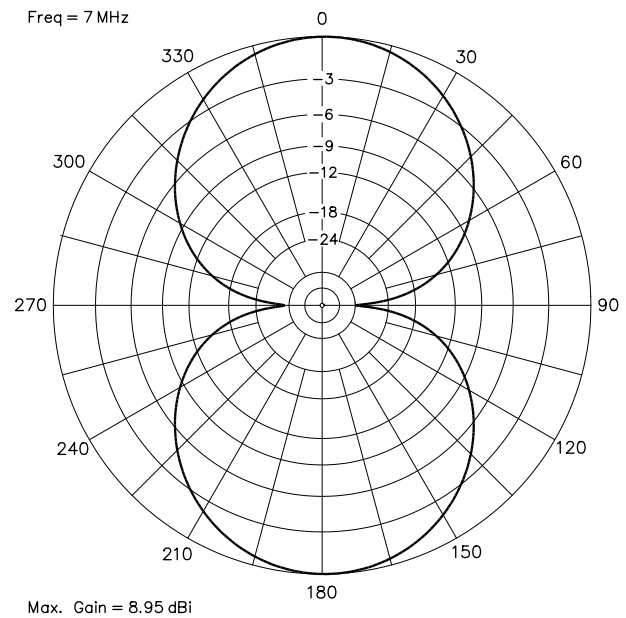
### HALF-SQUARE ANTENNA

On the low-frequency bands (40, 80 and 160 meters) it becomes increasingly difficult to use  $\lambda/2$  elements because of their size. The half-square antenna is a 2-element broadside array with  $\lambda/4$ -high vertical elements and  $\lambda/2$  horizontal spacing. See Fig 50. The free-space H-plane pattern for this array is shown in Fig 51. The antenna gives modest (4.2 dBi) but useful gain and has the advantage of only  $\lambda/4$  height. Like all vertically polarized antennas, real-world performance depends directly on the characteristics of the ground surrounding it.

The half-square can be fed either at the point indicated or at the bottom end of one of the vertical elements using a voltage feed scheme, such as that shown in Fig 52 for the bobtail curtain. The feed-point impedance is in the region of  $50 \Omega$  when fed at a corner as shown in Fig 50. A typical SWR plot is shown in Fig 53. Chapter 6 has a detailed discussion of the half-square antenna with several variations, together with practical considerations.



**Fig 50—Layout for the half-square antenna.**



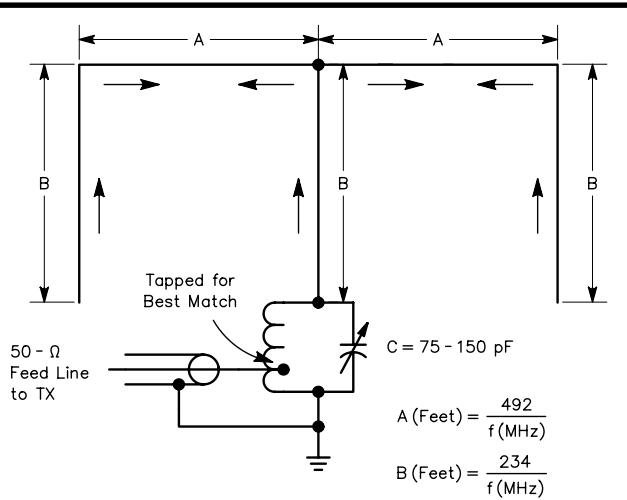
**Fig 51—Free-space E-plane directive pattern for the half-square antenna.**

### BOBTAIL CURTAIN

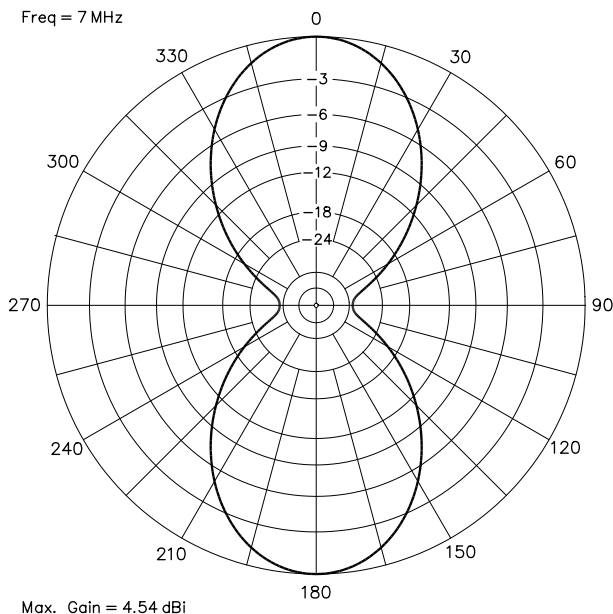
The antenna system in Fig 52 uses the principles of co-phased verticals to produce a broadside, bidirectional pattern providing approximately 5.1 dB of gain over a single  $\lambda/4$  element. The antenna performs as three in-phase, top-fed vertical radiators approximately  $\lambda/4$  in height and spaced approximately  $\lambda/2$ . It is most effective for low-angle signals and makes an excellent long-distance antenna for 1.8, 3.5 or 7 MHz.

The three vertical sections are the actual radiating components, but only the center element is fed directly. The two horizontal parts, A, act as phasing lines and contribute very little to the radiation pattern. Because the current in the center element must be divided between the end sections, the current distribution approaches a binomial 1:2:1 ratio. The radiation pattern is shown in Fig 54.

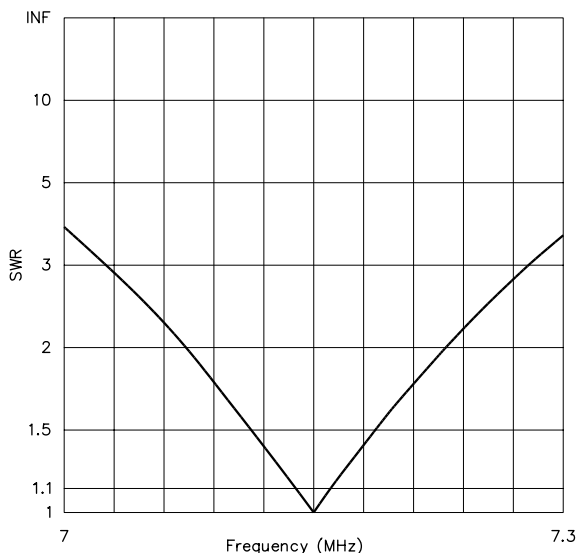
The vertical elements should be as vertical as possible.



**Fig 52**—The bobtail curtain is an excellent low-angle radiator having broadside bidirectional characteristics. Current distribution is represented by the arrows. Dimensions A and B (in feet, for wire antennas) can be determined from the equations.



**Fig 54**—Calculated free-space E-plane directive diagram of the bobtail curtain shown in Fig 52. The array lies along the 90°-270° axis.



**Fig 53**—Typical SWR plot for a 40-meter half-square antenna fed at one corner. Antenna in free space.

The height for the horizontal portion should be slightly greater than B, as shown in Fig 52. The tuning network is resonant at the operating frequency. The L/C ratio should be fairly low to provide good loading characteristics. As a starting point, a maximum capacitor value of 75 to 150 pF is recommended, and the inductor value is determined by C and the operating frequency. The network is first tuned to resonance and then the tap point is adjusted for the best match. A slight readjustment of C may be necessary. A link coil consisting of a few turns can also be used to feed the antenna.

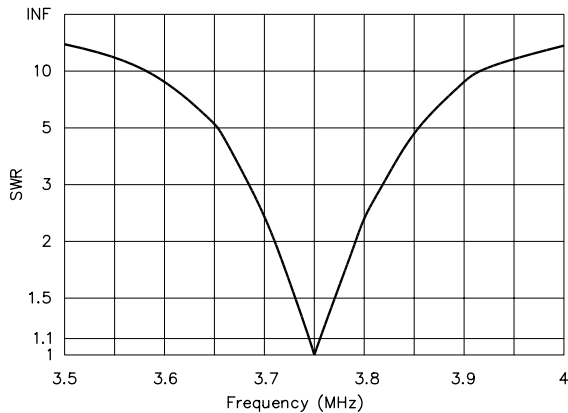
A feeling for the matching bandwidth of this antenna

can be obtained by looking at a feed point located at the top end of the center element. The impedance at this point will be approximately 32 Ω. An SWR plot (for  $Z_0 = 32 \Omega$ ) for an 80-meter bobtail curtain at this feed-point is shown in Fig 55. However, it is not advisable to actually connect a feedline at this point since it would detune the array and alter the pattern. This antenna is relatively narrow band. When fed at the bottom of the center element as shown in Fig 52, the SWR can be adjusted to be 1:1 at one frequency but the operating bandwidth for SWR < 2:1 may be even narrower than Fig 55 shows. For 80-meters, where operation is often desired in the CW DX window (3.510 MHz) and in the phone DX window (3.790 MHz), it will be necessary to retune the matching network as you change frequency. This can be done by switching a capacitor in or out, manually or remotely with a relay.

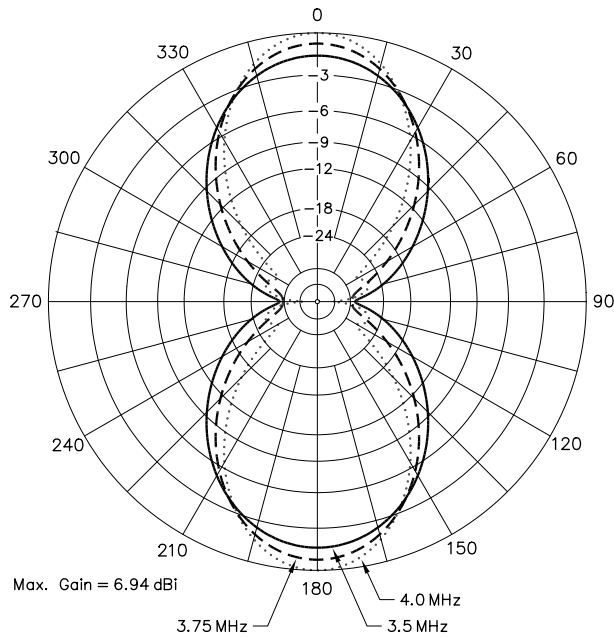
While the match bandwidth is quite narrow, the radiation pattern changes more slowly with frequency. Fig 56 shows the variation in the pattern over the entire band (3.5 to 4.0 MHz). As would be expected, the gain increases with frequency because the antenna is larger in terms of wavelengths. The general shape of the pattern, however, is quite stable.

### THE BRUCE ARRAY

Four variations of the Bruce array are shown in Fig 57. The Bruce is simply a wire folded so that the vertical sections carry large in-phase currents, while the horizontal sections carry small currents flowing in opposite directions with respect to the center of a section (indicated by dots). The radiation is vertically polarized. The gain is proportional



**Fig 55—Typical SWR plot for an 80-meter bobtail curtain in free space. This is a narrow-band antenna.**



**Fig 56—80-meter bobtail curtain’s free-space E-plane pattern variation over the 80-meter band.**

to the length of the array but is somewhat smaller than you can obtain from a broadside array of  $\lambda/2$  elements of the same length. This is because the radiating portion of the elements is only  $\lambda/4$ .

The Bruce array has a number of advantages:

- 1) The array is only  $\lambda/4$  high. This is especially helpful on 80 and 160 meters, where the height of  $\lambda/2$  supports becomes impractical for most amateurs.
- 2) The array is very simple. It is just a single piece of wire folded to form the array.
- 3) The dimensions of the array are very flexible. Depending on the available distance between supports, any number of elements can be used. The longer the array, the greater the gain.
- 4) The shape of the array does not have to be exactly  $1.05 \lambda/4$  squares. If the available height is short but the array can be made longer, then shorter vertical sections and longer horizontal sections can be used to maintain gain and resonance. Conversely, if more height is available but width is restricted then longer vertical sections can be used with shorter horizontal sections.
- 5) The array can be fed at other points more convenient for a particular installation.
- 6) The antenna is relatively low Q, so that the feed-point impedance changes slowly with frequency. This is very helpful on 80 meters, for example, where the antenna can be relatively broadband.
- 7) The radiation pattern and gain is stable over the width of an amateur band.

Note that the nominal dimensions of the array in Fig 57 call for section lengths =  $1.05 \lambda/4$ . The need to use slightly longer elements to achieve resonance is common in large wire arrays. A quad loop behaves in the same manner. This is quite different from wire dipoles which are typically *shortened* by 2-5% to achieve resonance.

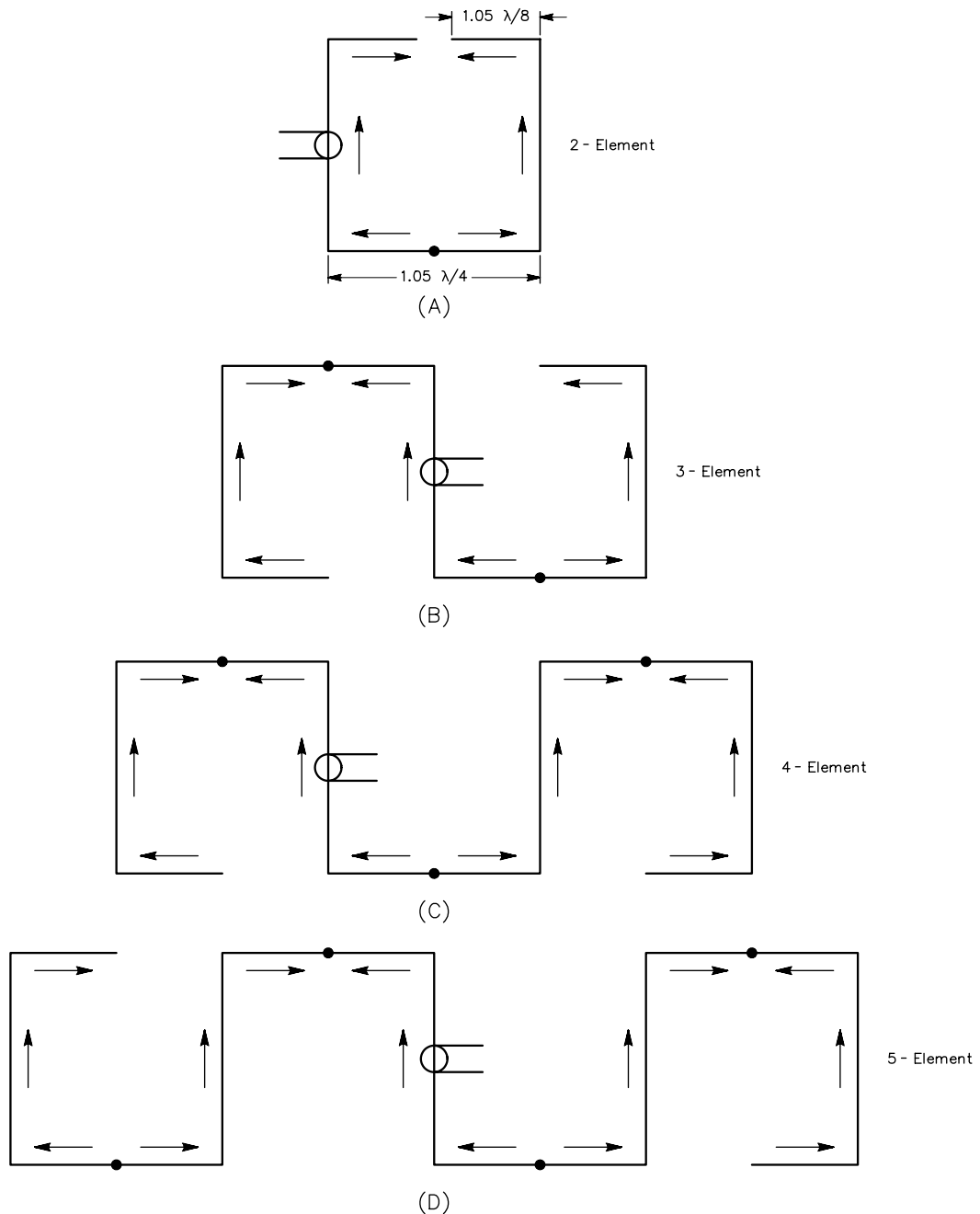
Fig 58 shows the variations in gain and pattern for 2- to 5-element 80-meter Bruce arrays. Table 7 lists the gain over a vertical  $\lambda/2$  dipole, a 4-radial ground-plane vertical and the size of the array. The gain and impedance parameters listed are for free space. Over real ground the patterns and gain will depend on the height above ground and the ground characteristics. Copper loss using #12 conductors is included.

Worthwhile gain can be obtained from these arrays,

**Table 7**

**Bruce array length, impedance and gain as a function of number of elements**

Number Elements	Gain Over $\lambda/2$ Vertical Dipole	Gain over $\lambda/4$ Ground-Plane	Array Length Wavelengths	Approx. Feed Z, $\Omega$
2	1.2 dB	1.9 dB	$1/4$	130
3	2.8 dB	3.6 dB	$1/2$	200
4	4.3 dB	5.1 dB	$3/4$	250
5	5.3 dB	6.1 dB	1	300

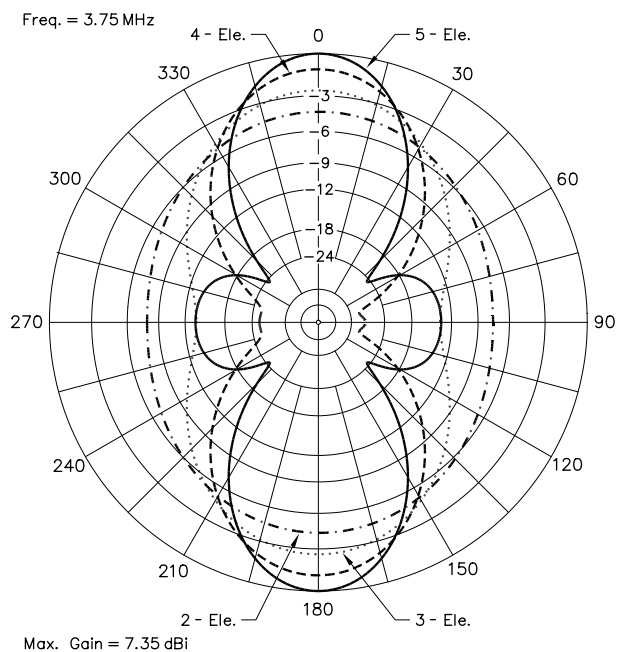


**Fig 57—Various Bruce arrays: 2, 3, 4 and 5-element versions.**

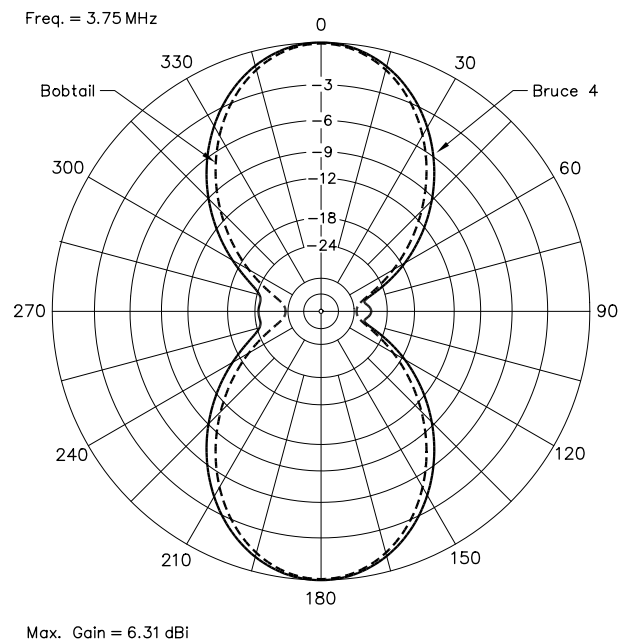
especially on 80 and 160 meters, where any gain is hard to come by. The feed-point impedance is for the center of a vertical section. From the patterns in Fig 58 you can see that sidelobes start to appear as the length of the array is increased beyond  $3/4 \lambda$ . This is typical for arrays using equal currents in the elements.

It is interesting to compare the bobtail curtain (Fig 52) with a 4-element Bruce array. Fig 59 compares the radiation patterns for these two antennas. Even though the Bruce is shorter ( $3/4 \lambda$ ) than the bobtail ( $1 \lambda$ ), it has slightly more

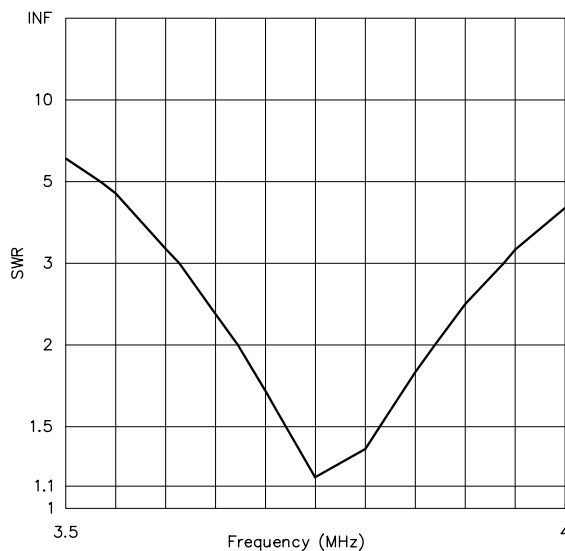
gain. The matching bandwidth is illustrated by the SWR curve in Fig 60. The 4-element Bruce has over twice the match bandwidth (200 kHz) than does the bobtail (75 kHz in Fig 55). Part of the gain difference is due to the binomial current distribution—the center element has twice the current as the outer elements in the bobtail. This reduces the gain slightly so that the 4-element Bruce becomes competitive. This is a good example of using more than the minimum number of elements to improve performance or to reduce size. On 160 meters the 4-element Bruce will be 140 feet



**Fig 58—80-meter free-space E-plane directive patterns for the Bruce arrays shown in Fig 57. The 5-element's pattern is a solid line; the 4-element is a dashed line; the 3-element is a dotted line, and the 2-element version is a dashed-dotted line.**



**Fig 59—Comparison of free space patterns of a 4-element Bruce array (solid line) and a 3-element bobtail curtain (dashed line).**



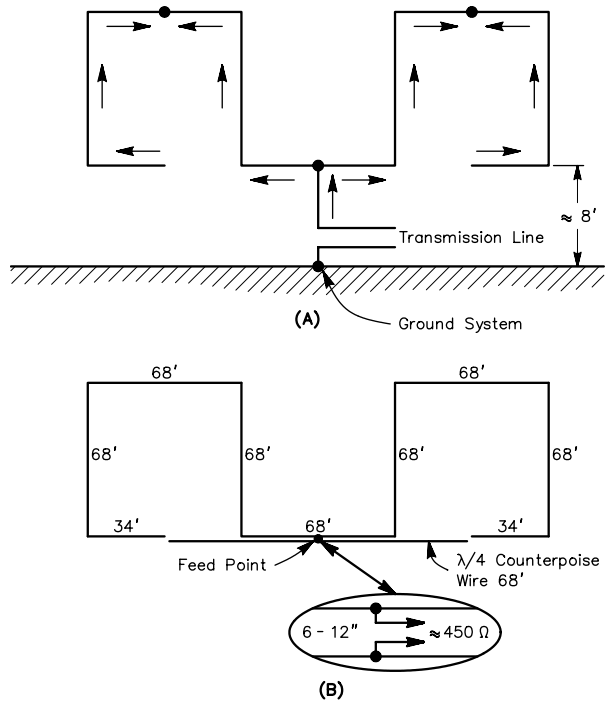
**Fig 60—Typical SWR curve for a 4-element 80-meter Bruce array.**

shorter than the bobtail, a significant reduction. If additional space is available for the bobtail ( $1\lambda$ ) then a 5-element Bruce could be used, with a small increase in gain but also introducing some sidelobes.

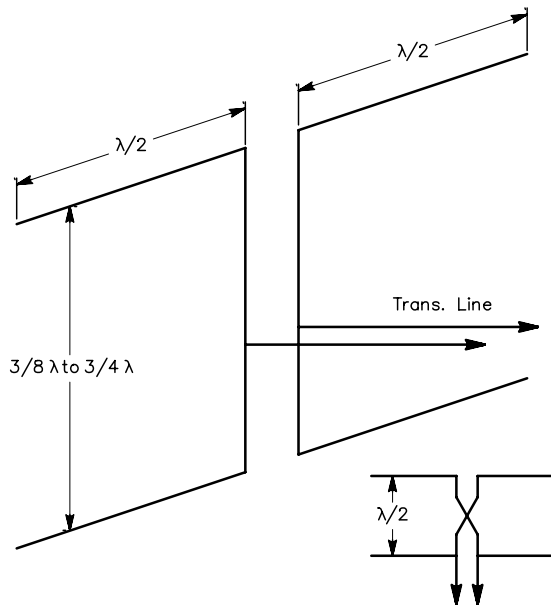
The 2-element Bruce and the half-square antennas are both 2-element arrays. However, since the spacing between radiators is greater in the half-square ( $\lambda/2$ ) the gain of the half-square is about 1 dB greater. If space is available, the half-square would be a better choice. If there is not room for a half-square then the Bruce, which is only half as long ( $\lambda/4$ ), may be a good alternative. The 3-element Bruce, which has the same length ( $\lambda/2$ ) as the half-square, has about 0.6 dB more gain than the half-square and will have a wider match bandwidth.

The Bruce antenna can be fed at many different points and in different ways. In addition to the feed points indicated in Fig 57, you may connect the feed line at the center of any of the vertical sections. In longer Bruce arrays, feeding at one end will result in some current imbalance among the elements but the resulting pattern distortion is small. Actually, the feed-point can be anywhere along a vertical section. One very convenient point is at an outside corner. The feed-point impedance will be higher (about 600  $\Omega$ ). A good match for 450- $\Omega$  ladder-line can usually be found somewhere on the vertical section. It is important to recognize that feeding the antenna at a voltage node (dots in Fig 57) by breaking the wire and inserting an insulator, completely changes the current distribution. This will be discussed in the section on endfire arrays.

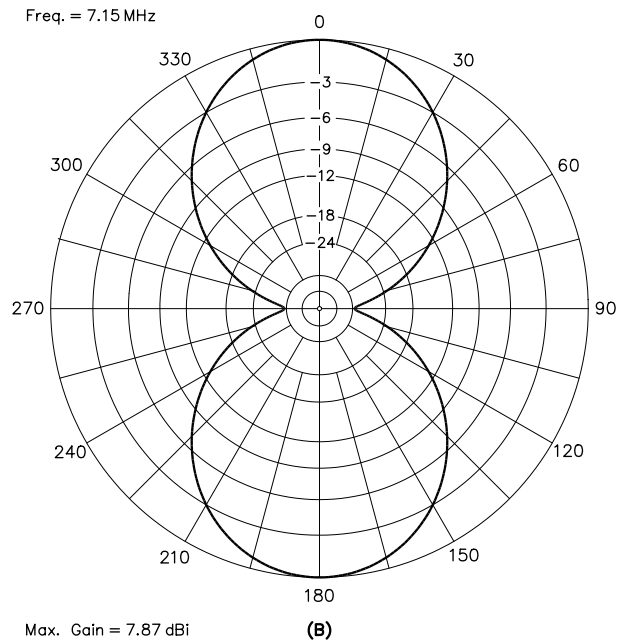
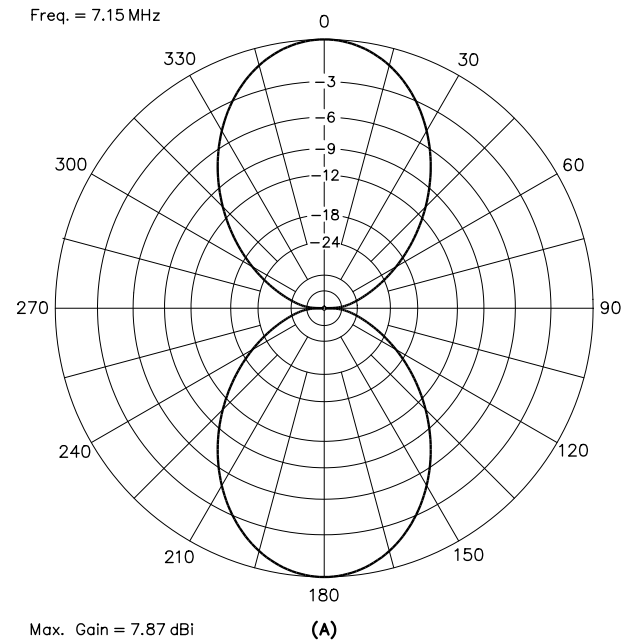
A Bruce can be fed unbalanced against ground or against a counterpoise as shown in Fig 61. Because it is a vertically polarized antenna, the better the ground system the better the performance. As few as two elevated radials can be used as shown in Fig 61B, but more radials can also be used to improve the performance, depending on local



**Fig 61—Alternate feed arrangements for the Bruce array. At A, the antenna is driven against a ground system and at B, it uses a two-wire counterpoise.**



**Fig 62—Four-element broadside array ("lazy H") using collinear and parallel elements.**



**Fig 63—Free-space directive diagrams of the four-element antenna shown in Fig 62. At A is the E-plane pattern. The axis of the elements lies along the 90°-270° line. At B is the free-space H-plane pattern, viewed as if one set of elements is above the other from the ends of the elements.**

ground constants. The original development of the Bruce array in the late 1920s used this feed arrangement.

#### FOUR-ELEMENT BROADSIDE ARRAY

The 4-element array shown in Fig 62 is commonly known as the *lazy H*. It consists of a set of two collinear elements and a set of two parallel elements, all operated in phase to give broadside directivity. The gain and directivity will depend on the spacing, as in the case of a simple parallel-element broadside array. The spacing may be chosen between the limits shown on the drawing, but spacings below  $\frac{3}{8}\lambda$  are not worthwhile because the gain is small. Estimated gains compared to a single element are:

- $\frac{3}{8}\lambda$  spacing—4.2 dB
- $\frac{1}{2}\lambda$  spacing—5.8 dB
- $\frac{5}{8}\lambda$  spacing—6.7 dB
- $\frac{3}{4}\lambda$  spacing—6.3 dB

Half-wave spacing is generally used. Directive patterns for this spacing are given in Figs 63 and 64. With  $\frac{1}{2}\lambda$  spacing between parallel elements, the impedance at the junction of the phasing line and transmission line is resistive and in the vicinity of  $100\ \Omega$ . With larger or smaller spacing the impedance at this junction will be reactive as well as resistive. Matching stubs are recommended in cases where a non-resonant line is to be used. They may be calculated and adjusted as described in Chapter 26.

The system shown in Fig 62 may be used on two bands having a 2-to-1 frequency relationship. It should be designed for the higher of the two frequencies, using  $\frac{3}{4}\lambda$  spacing between parallel elements. It will then operate on the lower frequency as a simple broadside array with  $\frac{3}{8}\lambda$  spacing.

An alternative method of feeding is shown in the small diagram in Fig 62. In this case the elements and the phasing line must be adjusted exactly to an electrical half wavelength. The impedance at the feed point will be resistive and on the order of  $2\ \text{k}\Omega$ .

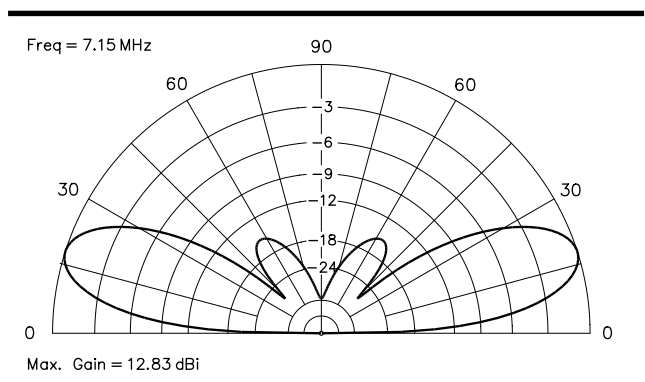


Fig 64—Vertical pattern of the four-element broadside antenna of Fig 62, when mounted with the elements horizontal and the lower set  $\frac{1}{2}\lambda$  above flat ground. Stacked arrays of this type give best results when the lowest elements are at least  $\frac{1}{2}\lambda$  high. The gain is reduced and the wave angle raised if the lowest elements are too close to ground.

#### THE BI-SQUARE ANTENNA

A development of the lazy H, known as the *bi-square antenna*, is shown in Fig 65. The gain of the bi-square is somewhat less than that of the lazy-H, but this array is attractive because it can be supported from a single pole. It has a circumference of  $2\lambda$  at the operating frequency, and is horizontally polarized.

The bi-square antenna consists of two  $1\lambda$  radiators, fed  $180^\circ$  out of phase at the bottom of the array. The radiation resistance is  $300\ \Omega$ , so it can be fed with either 300- or 600- $\Omega$  line. The free space gain of the antenna is about 5.8 dB, which is 3.7 dB more than a single dipole element. Gain may be increased by adding a parasitic reflector or director. Two bi-square arrays can be mounted at right angles and switched to provide omnidirectional coverage. In this way, the antenna wires may be used as part of the guying system for the pole.

Although it resembles a loop antenna, the bi-square is not a true loop because the ends opposite the feed point are open. However, identical construction techniques can be used for the two antenna types. Indeed, with a means of remotely closing the connection at the top for lower frequency operation, the antenna can be operated on two harmonically related bands. As an example, an array with 17 feet per side can be operated as a bi-square at 28 MHz and as a full-wave loop at 14 MHz. For two-band operation in this manner, the side length should favor the higher frequency. The length of a closed loop is not as critical.

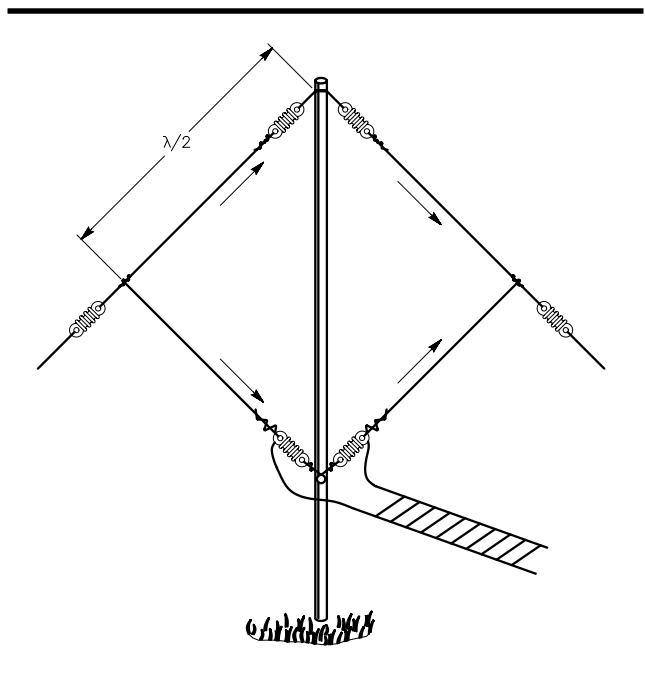


Fig 65—The bi-square array. It has the appearance of a loop, but is not a true loop because the conductor is open at the top. The length of each side, in feet, is  $480/f$  (MHz).

# End-Fire Arrays

The term *end-fire* covers a number of different methods of operation, all having in common the fact that the maximum radiation takes place along the array axis, and that the array consists of a number of parallel elements in one plane. End-fire arrays can be either bidirectional or unidirectional. In the bidirectional type commonly used by amateurs there are only two elements, and these are operated with currents 180° out of phase. Even though adjustment tends to be complicated, unidirectional end-fire driven arrays have also seen amateur use, primarily as a pair of phased, ground-mounted  $\frac{1}{4} \lambda$  vertical elements. Extensive discussion of this array is contained in earlier sections of this chapter.

Horizontally polarized unidirectional end-fire arrays see little amateur use except in log-periodic arrays (described in Chapter 10). Instead, horizontally polarized unidirectional arrays usually have parasitic elements (described in Chapter 11).

## TWO-ELEMENT END-FIRE ARRAY

In a 2-element array with equal currents out of phase, the gain varies with the spacing between elements as shown in Fig 66. The maximum gain occurs in the neighborhood of  $0.1 \lambda$  spacing. Below that the gain drops rapidly due to conductor loss resistance.

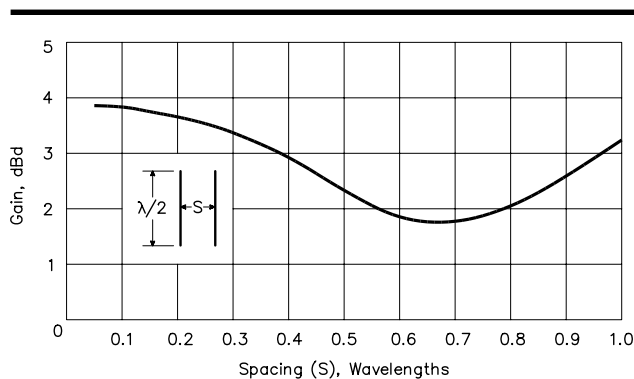
The feed-point resistance for either element is very low at the spacings giving greatest gain, as shown in Fig 8 earlier in this chapter. The spacings most frequently used are  $\frac{1}{8} \lambda$  and  $\frac{1}{4} \lambda$ , at which the resistances of center-fed  $\frac{1}{2} \lambda$  elements are about 9 and 32  $\Omega$ , respectively.

The effect of conductor resistance on gain for various spacings is shown in Fig 67. Because current along the element is not constant (it is approximately sinusoidal), the resistance shown is the equivalent resistance ( $R_{eq}$ ) inserted at the center of the element to account for the loss distributed along the element.

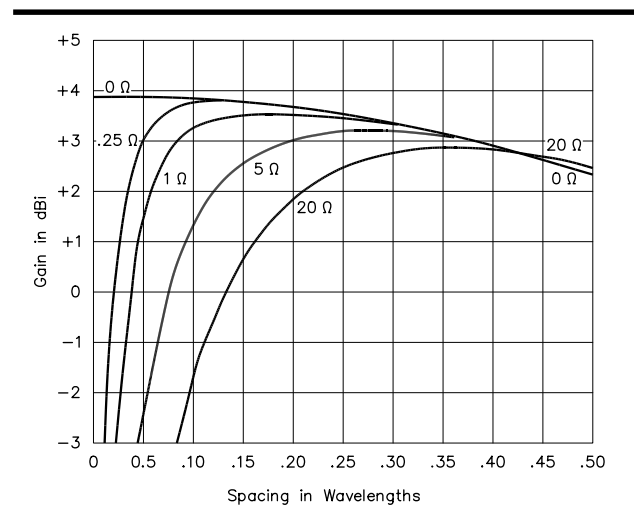
The equivalent resistance of a  $\lambda/2$  element is  $\frac{1}{2}$  the AC resistance ( $R_{ac}$ ) of the complete element.  $R_{ac}$  is usually  $\gg R_{dc}$  due to skin effect. For example, a 1.84 MHz dipole using #12 copper wire will have the following  $R_{eq}$ :

Wire length = 267 feet  
 $R_{dc} = 0.00159 [\Omega/\text{foot}] \times 267 [\text{feet}] = 0.42 \Omega$   
 $Fr = R_{ac}/R_{dc} = 10.8$   
 $R_{eq} = (R_{dc}/2) \times Fr = 2.29 \Omega$   
 For a 3.75 MHz dipole made with #12 wire,  $R_{eq} = 1.59 \Omega$ .

In Fig 67, it is clear that end-fire antennas made with #12 or smaller wire will limit the attainable gain because of losses. There is no point in using spacings much less than  $0.25 \lambda$  if you use wire elements. If instead you use elements made of aluminum tubing then smaller spacings can be used to increase gain. However, as the spacing is reduced below  $0.25 \lambda$  the increase in gain is quite small even with good conductors. Closer spacings give little gain increase but can drastically reduce the operating bandwidth due to the rapidly increasing Q of the array.



**Fig 66—Gain of an end-fire array consisting of two elements fed 180° out of phase, as a function of the spacing between elements. Maximum radiation is in the plane of the elements and at right angles to them at spacings up to  $\frac{1}{2} \lambda$ , but the direction changes at greater spacings.**



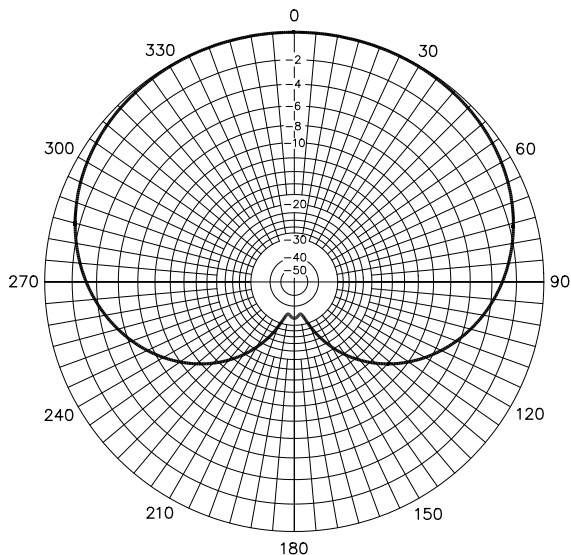
**Fig 67—Gain over a single element of two out-of-phase elements in free space as a function of spacing for various loss resistances.**

## Unidirectional End-Fire Arrays

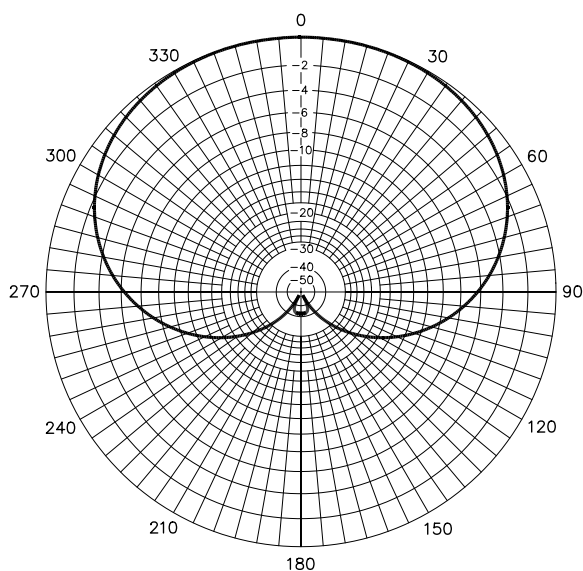
Two parallel elements spaced  $\frac{1}{4} \lambda$  apart and fed equal currents 90° out of phase will have a directional pattern in the plane at right angles to the plane of the array. See Fig 68. The maximum radiation is in the direction of the element in which the current lags. In the opposite direction the fields from the two elements cancel.

When the currents in the elements are neither in phase nor 180° out of phase, the feed-point resistances of the elements are not equal. This complicates the problem of feeding equal currents to the elements, as discussed in earlier sections.





**Fig 68—Representative H-plane pattern for a 2-element end-fire array with 90° spacing and phasing. The elements lie along the vertical axis, with the uppermost element the one of lagging phase. Dissimilar current distributions are taken into account. (Pattern computed with *ELNEC*.)**



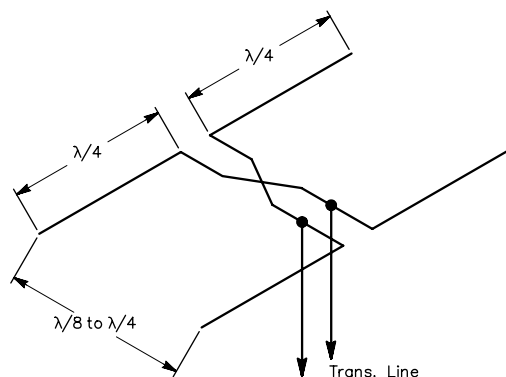
**Fig 69—H-plane pattern for a 3-element end-fire array with binomial current distribution (the current in the center element is twice that in each end element). The elements are spaced  $\frac{1}{4} \lambda$  apart along the 0°-180° axis. The center element lags the lower element by 90°, while the upper element lags the lower element by 180° in phase. Dissimilar current distributions are taken into account. (Pattern computed with *ELNEC*.)**

More than two elements can be used in a unidirectional end-fire array. The requirement for unidirectivity is that there must be a progressive phase shift in the element currents equal to the spacing, in electrical degrees, between the elements. The amplitudes of the currents in the various elements also must be properly related. This requires binomial current distribution. In the case of three elements, this requires that the current in the center element be twice that in the two outside elements, for 90° ( $\frac{1}{4} \lambda$ ) spacing and element current phasing. This antenna has an overall length of  $\frac{1}{2} \lambda$ . The directive diagram is shown in Fig 69. The pattern is similar to that of Fig 68, but the 3-element binomial array has greater directivity, evidenced by the narrower half-power beamwidth (146° versus 176°). Its gain is 1.0 dB greater.

### THE W8JK ARRAY

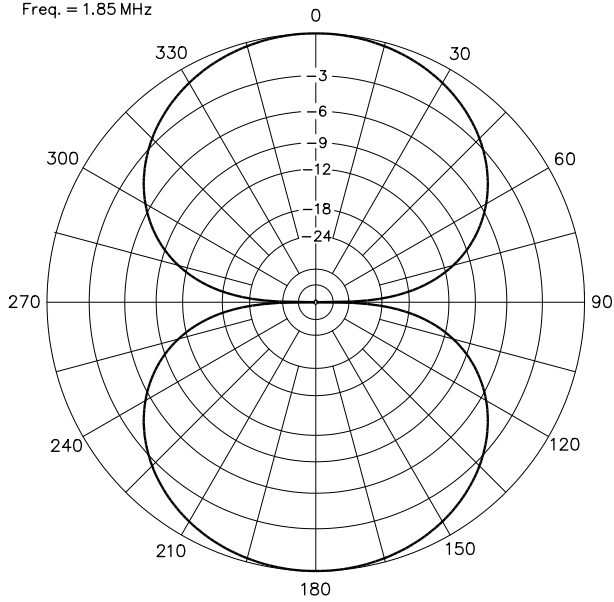
As pointed out earlier, John Kraus, W8JK, described his bi-directional flat-top W8JK beam antenna in 1940. See Fig 70. Two  $\frac{\lambda}{2}$  elements are spaced  $\frac{\lambda}{8}$  to  $\frac{\lambda}{4}$  and driven 180° out of phase. The free-space radiation pattern for this antenna, using #12 copper wire, is given in Fig 71. The pattern is representative of spacings between  $\frac{\lambda}{8}$  and  $\frac{\lambda}{4}$  where the gain varies less than 0.5 dB. The gain over a dipole is about 3.3 dB (5.4 dBi referenced to an isotropic radiator), a worthwhile improvement. The feed-point impedance (including wire resistance) of *each* element is about 11  $\Omega$  for  $\frac{\lambda}{8}$  spacing and 33  $\Omega$  for  $\frac{\lambda}{4}$  spacing. The feed-point impedance at the center connection will depend on the length and  $Z_0$  of the connecting transmission line.

Kraus gave a number of other variations for end-fire arrays, some of which are shown in Fig 72. The ones fed at the center (A, C and E) are usually horizontally polarized flat-top beams. The end-fed versions (B, D & F) are usually vertically polarized, where the feed point can be conveniently near ground. A practical variation of Fig 72B is given in Fig 73. In this example, the height is limited to  $\frac{\lambda}{4}$  so the ends can be bent over as shown, producing a 2-element end-fire array. This reduces the gain somewhat but allows much



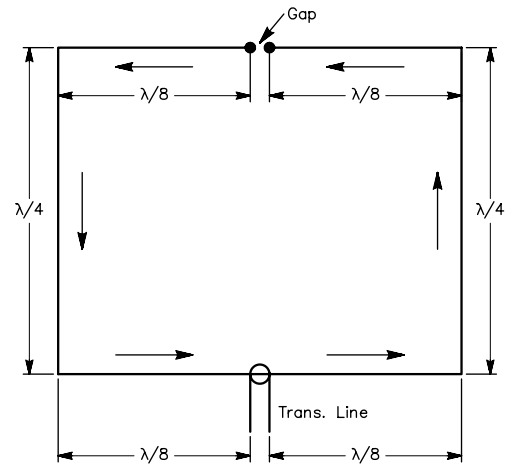
**Fig 70—A 2-element W8JK array.**

Freq. = 1.85 MHz

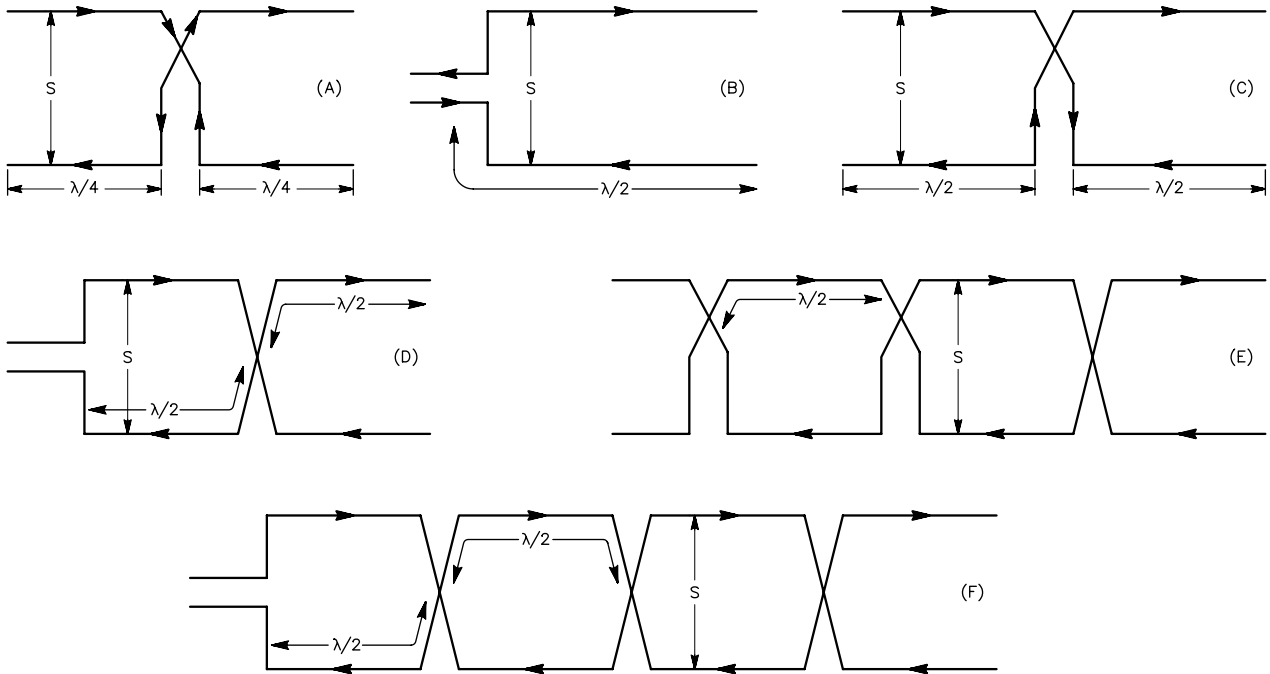


Max. Gain = 5.39 dBi

**Fig 71—Free-space E-plane pattern for the 2-element W8JK array**



**Fig 73—A 2-element end-fire array with reduced height.**



**Fig 72—Six other variations of W8JK “flat-top beam” antennas.**

shorter supports, an important consideration on the low bands. If additional height is available, then you can achieve some additional gain. The upper ends can be bent over to fit the available height. The feed-point impedance will be greater than  $1\text{ k}\Omega$ .

### FOUR-ELEMENT END-FIRE AND COLLINEAR ARRAYS

The array shown in **Fig 74** combines collinear in-phase elements with parallel out-of-phase elements to give both broadside and end-fire directivity. It is a *two-section W8JK*. The approximate free-space gain using #12 copper wire is 4.9 dBi with  $1/8\lambda$  spacing and 5.4 dBi with  $1/4\lambda$  spacing. Directive patterns are given in **Figs 75** for free space, and in **Fig 76** for heights of  $1\lambda$  and  $1/2\lambda$  above flat ground.

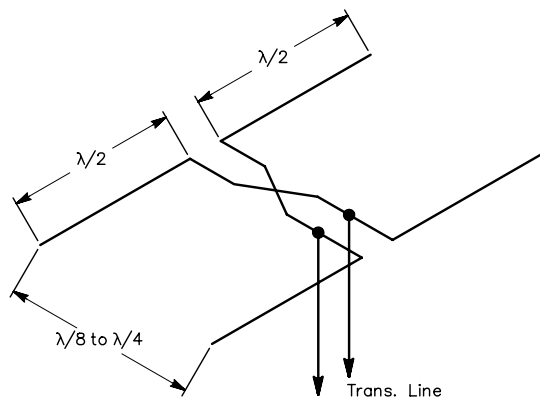
The impedance between elements at the point where the phasing line is connected is of the order of several thousand ohms. The SWR with an unmatched line consequently is quite high, and this system should be constructed with open-wire line ( $500$  or  $600\ \Omega$ ) if the line is to be resonant. With  $\lambda/4$  element spacing the SWR on a  $600\ \Omega$  line is estimated to be in the vicinity of 3 or 4:1.

To use a matched line, you could connect a closed stub  $3/16\lambda$  long at the transmission-line junction shown in **Fig 74**. The transmission line itself can then be tapped on this matching section at the point resulting in the lowest line SWR. This point can be determined by trial.

This type of antenna can be operated on two bands having a frequency ratio of 2 to 1, if a resonant feed line is used. For example, if you design for 28 MHz with  $\lambda/4$  spacing between elements, you can also operate on 14 MHz as a simple 2-element end-fire array having  $\lambda/8$  spacing.

### Combination Driven Arrays

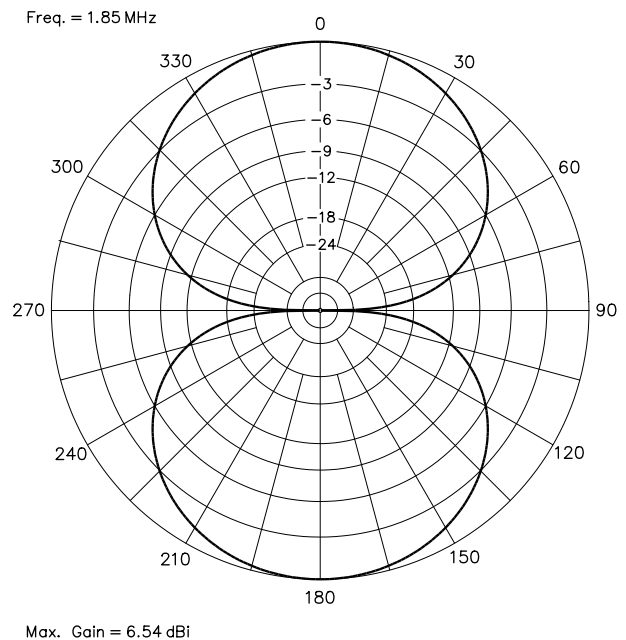
You can readily combine broadside, end-fire and collinear elements to increase gain and directivity, and this is in fact usually done when more than two elements are



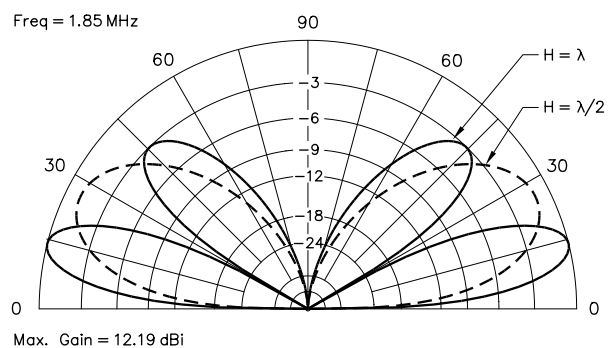
**Fig 74**—A four-element array combining collinear broadside elements and parallel end-fire elements, popularly known as a two-section W8JK array.

used in an array. Combinations of this type give more gain, in a given amount of space, than plain arrays of the types just described. Since the combinations that can be worked out are almost endless, this section describes only a few of the simpler types.

The accurate calculation of the power gain of a multi-element array requires a knowledge of the mutual impedances between all elements, as discussed in earlier sections. For approximate purposes it is sufficient to assume that each set (collinear, broadside, end-fire) will have the gains as given earlier, and then simply add up the gains for the combination.



**Fig 75**—Free-space E-plane pattern for the antenna shown in **Fig 74**, with  $1/8\lambda$  spacing. The elements are parallel to the  $90^\circ$ - $270^\circ$  line in this diagram. Less than a  $1^\circ$  change in half-power beamwidth results when the spacing is changed from  $1/8$  to  $1/4\lambda$ .



**Fig 76**—Elevation-plane pattern for the four-element antenna of **Fig 74** when mounted horizontally at two heights over flat ground. Solid line =  $1\lambda$  high; dashed line =  $1/2\lambda$  high.

This neglects the effects of cross-coupling between sets of elements. However, the array configurations are such that the mutual impedances from cross-coupling should be relatively small, particularly when the spacings are  $\frac{1}{4}\lambda$  or more, so the estimated gain should be reasonably close to the actual gain. Alternatively, an antenna modeling program will give good estimates of all parameters for a real-world antenna, providing that you take care to model all applicable parameters.

#### FOUR-ELEMENT DRIVEN ARRAYS

The array shown in Fig 77 combines parallel elements with broadside and end-fire directivity. The smallest array (physically)— $\frac{3}{8}\lambda$  spacing between broadside and  $\frac{1}{8}\lambda$  spacing between end-fire elements—has an estimated gain of 6.5 dBi and the largest— $\frac{3}{4}\lambda$  and  $\frac{1}{4}\lambda$  spacing, respectively—about 8.4 dBi. Typical directive patterns for a  $\frac{1}{4} \times \frac{1}{2}\lambda$  array are given in Figs 78 and 79.

The impedance at the feed point will not be purely resistive unless the element lengths are correct and the phasing lines are exactly  $\frac{1}{2}\lambda$  long. (This requires somewhat

less than  $\frac{1}{2}\lambda$  spacing between broadside elements.) In this case the impedance at the junction is estimated to be over 10 k $\Omega$ . With other element spacings the impedance at the junction will be reactive as well as resistive, but in any event the SWR will be quite large. An open-wire line can be used as a resonant line, or a matching section may be used for non-resonant operation.

#### EIGHT-ELEMENT DRIVEN ARRAYS

The array shown in Fig 80 is a combination of collinear and parallel elements in broadside and end-fire directivity. Common practice in a wire antenna is to use  $\frac{1}{2}\lambda$  spacing for the parallel broadside elements and  $\frac{1}{4}\lambda$  spacing for the end-fire elements. This gives a free-space gain of about 9.1 dBi. Directive patterns for an array using these spacings are similar to those of Figs 78 and 79, but are somewhat sharper.

The SWR with this arrangement will be high. Matching stubs are recommended for making the lines non-resonant. Their position and length can be determined as described in Chapter 26.

This system can be used on two bands related in

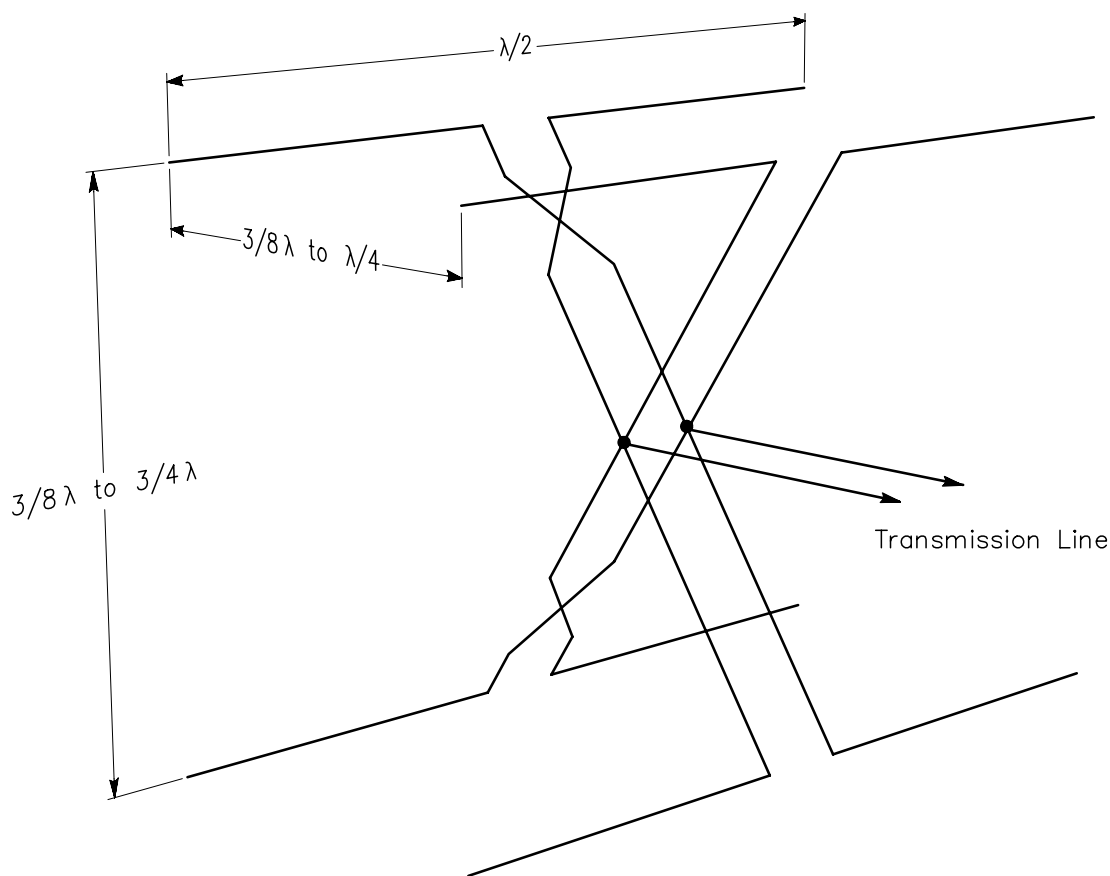
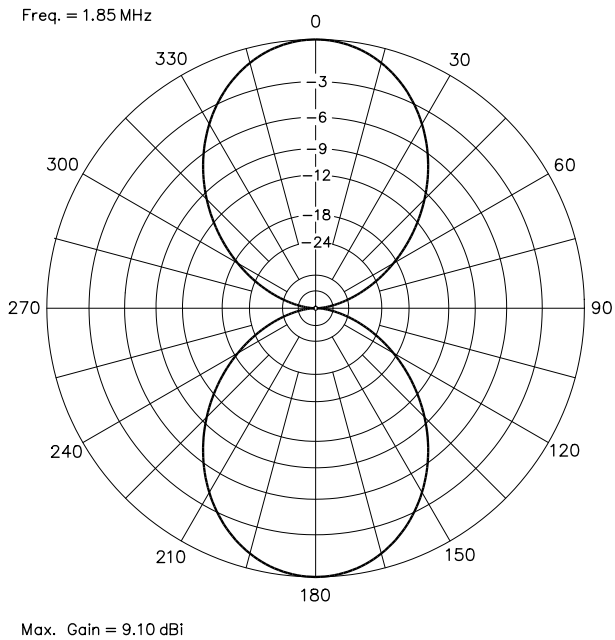
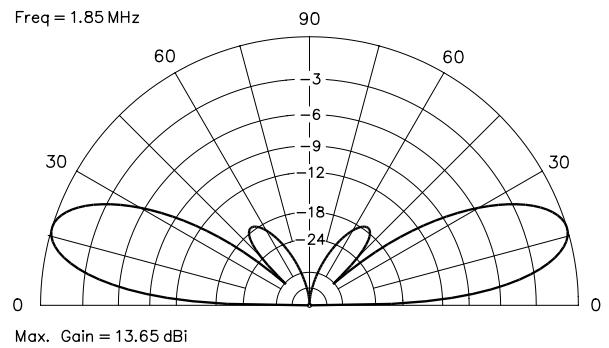


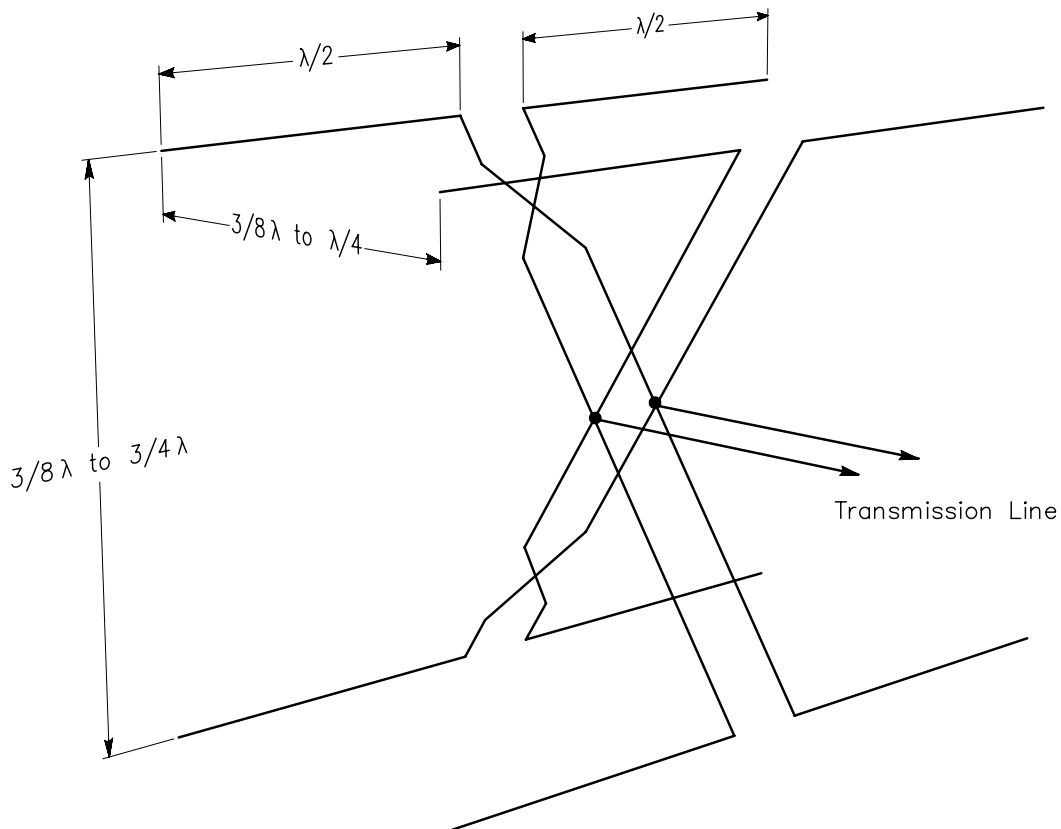
Fig 77—Four-element array combining both broadside and end-fire elements.



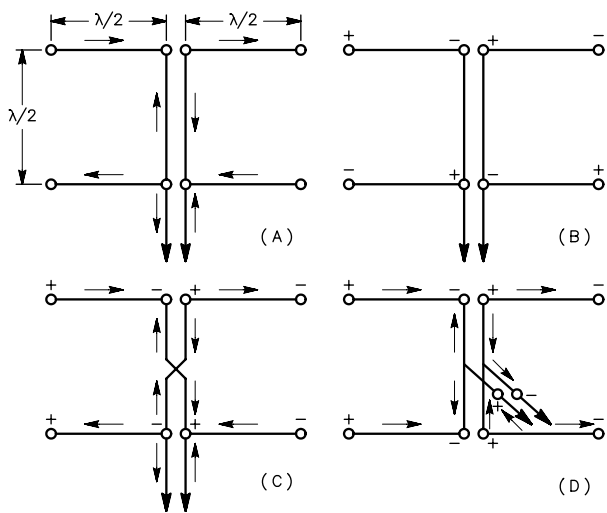
**Fig 78**—Free-space H-plane pattern of the four-element antenna shown in Fig 77.



**Fig 79**—Vertical pattern of the antenna shown in Fig 77 at a mean height of  $\frac{3}{4} \lambda$  (lowest elements  $\frac{1}{2} \lambda$  above flat ground) when the antenna is horizontally polarized. For optimum gain and low wave angle the mean height should be at least  $\frac{3}{4} \lambda$ .



**Fig 80**—Eight-element driven array combining collinear and parallel elements for broadside and end-fire directivity.



**Fig 81—Methods of checking the phase of currents in elements and phasing lines.**

frequency by a 2-to-1 ratio, providing it is designed for the higher of the two, with  $\frac{3}{4} \lambda$  spacing between the parallel broadside elements and  $\frac{1}{4} \lambda$  spacing between the end-fire elements. On the lower frequency it will then operate as a four-element antenna of the type shown in Fig 77, with  $\frac{3}{8} \lambda$  broadside spacing and  $\frac{1}{8} \lambda$  end-fire spacing. For two-band operation a resonant transmission line must be used.

### PHASING ARROWS IN ARRAY ELEMENTS

In the antenna diagrams of preceding sections, the relative direction of current flow in the various antenna elements and connecting lines was shown by arrows. In laying out any antenna system it is necessary to know that the phasing lines are properly connected; otherwise the antenna may have entirely different characteristics than anticipated. The phasing may be checked either on the basis of current direction or polarity of voltages. There are two rules to remember:

- 1) In every  $\frac{1}{2} \lambda$  section of wire, starting from an open end, the current directions reverse. In terms of voltage, the polarity reverses at each  $\frac{1}{2} \lambda$  point, starting from an open end.
- 2) Currents in transmission lines always must flow in opposite directions in adjacent wires. In terms of voltage, polarities always must be opposite.

Examples of the use of current direction and voltage polarity are given at A and B, respectively, in Fig 81. The  $\lambda/2$  points in the system are marked by small circles. When current in one section flows toward a circle, the current in the next section must also flow toward it, and vice versa. In the four-element antenna shown at A, the current in the upper right-hand element cannot flow toward the transmission line, because then the current in the right-hand section of the

phasing line would have to flow upward and thus would be flowing in the same direction as the current in the left-hand wire. The phasing line would simply act like two wires in parallel in such a case. Of course, all arrows in the drawing could be reversed, and the net effect would be unchanged.

C shows the effect of transposing the phasing line. This transposition reverses the direction of current flow in the lower pair of elements, as compared with A, and thus changes the array from a combination collinear and end-fire arrangement into a collinear-broadside array.

The drawing at D shows what happens when the transmission line is connected at the center of a section of phasing line. Viewed from the main transmission line, the two parts of the phasing line are simply in parallel, so the half wavelength is measured from the antenna element along the upper section of phasing line and thence along the transmission line. The distance from the lower elements is measured in the same way. Obviously the two sections of phasing line should be the same length. If they are not, the current distribution becomes quite complicated; the element currents are neither in phase nor  $180^\circ$  out of phase, and the elements at opposite ends of the lines do not receive the same current. To change the element current phasing at D into the phasing at A, simply transpose the wires in one section of the phasing line; this reverses the direction of current flow in the antenna elements connected to that section of phasing line.

### BIBLIOGRAPHY

Source material and more extended discussion of topics covered in this chapter can be found in the references given below and in the textbooks listed at the end of Chapter 2.

- D. W. Atchley, H. E. Stinehelfer, and J. F. White, "360°-Steerable Vertical Phased Arrays," *QST*, Apr 1976, pp 27-30.
- G. H. Brown, "Directional Antennas," *Proc. IRE*, Vol 25, No. 1, Jan 1937, pp 78-145.
- G. H. Brown, R. F. Lewis and J. Epstein, "Ground Systems as a Factor in Antenna Efficiency," *Proc. IRE*, Jun 1937, pp 753-787.
- G. H. Brown and O. M. Woodward, Jr., "Experimentally Determined Impedance Characteristics of Cylindrical Antennas," *Proc. IRE*, Apr 1945.
- A. Christman, "Feeding Phased Arrays: An Alternate Method," *Ham Radio*, May 1985, pp 58-59, 61-64.
- ELNEC* and *EZNEC* are antenna-modeling computer programs for the IBM PC and compatibles, permitting the use of true current sources. They are available commercially from Roy W. Lewallen, W7EL, 5470 SW 152 Ave, Beaverton, OR 97007.
- F. Gehrke, "Vertical Phased Arrays," in six parts, *Ham Radio*, May-Jul, Oct and Dec 1983, and May 1984.
- C. Harrison, Jr, and R. King, "Theory of Coupled Folded Antennas," *IRE Trans on Antennas and Propagation*, Mar 1960, pp131-135.
- W. Hayward and D. DeMaw, *Solid State Design for the*

- Radio Amateur* (Newington, CT: ARRL, 1977).
- W. Hayward, *Radio Frequency Design* (Newington, CT: ARRL, 1994).
- H. Jasik, *Antenna Engineering Handbook*, 1st ed. (New York: McGraw-Hill, 1961).
- R. King and C. Harrison, Jr, "Mutual and Self-Impedance for Coupled Antennas," *Journal of Applied Physics*, Vol 15, Jun 1944, pp 481-495.
- R. King, "Self- and Mutual Impedances of Parallel Identical Antennas," *Proc. IRE*, Aug 1952, pp 981-988.
- R. W. P. King, *Theory of Linear Antennas* (Cambridge, MA: Harvard Univ Press, 1956), p 275ff.
- H. W. Kohler, "Antenna Design for Field-Strength Gain," *Proc. IRE*, Oct 1944, pp 611-616.
- J. D. Kraus, "Antenna Arrays with Closely Spaced Elements," *Proc. IRE*, Feb, 1940, pp 76-84.
- J. D. Kraus, *Antennas*, 2nd ed. (New York: McGraw-Hill Book Co., 1988).
- E. A. Laport, *Radio Antenna Engineering* (New York: McGraw-Hill Book Co, 1952).
- J. L. Lawson, "Simple Arrays of Vertical Antenna Elements," *QST*, May 1971, pp 22-27.
- P. H. Lee, *The Amateur Radio Vertical Antenna Handbook*, 1st ed. (Port Washington, NY: Cowan Publishing Corp., 1974).
- R. W. Lewallen, "Baluns: What They Do and How They Do It," *The ARRL Antenna Compendium Volume 1* (Newington: ARRL, 1985).
- R. Lewallen, "The Impact of Current Distribution on Array Patterns," Technical Correspondence, *QST*, Jul 1990, pp 39-40.
- M. W. Maxwell, "Some Aspects of the Balun Problem," *QST*, Mar 1983, pp 38-40.
- J. Sevick, "The Ground-Image Vertical Antenna," *QST*, Jul 1971, pp 16-19, 22.
- J. Sevick, "The W2FMI Ground-Mounted Short Vertical," *QST*, Mar 1973, pp 13-28,41.
- E. J. Wilkinson, "An N-Way Hybrid Power Divider," *IRE Transactions on Microwave Theory and Techniques*, Jan, 1960.
- Radio Broadcast Ground Systems*, available from Smith Electronics, Inc, 8200 Snowville Rd, Cleveland, OH 44141.

## Chapter 9

# Broadband Antenna Matching

Antennas systems that provide a good impedance match to the transmitter over a wide frequency range have been a topic of interest to hams for many years. Most emphasis has been focused on the 80-meter band, since a conventional half-wave dipole will provide better than 2:1 SWR over only about one-third of the 3.5 to 4.0 MHz band. The advantage of a broadband match is obvious—fewer adjustments during tune-up and an antenna tuner may not be required.

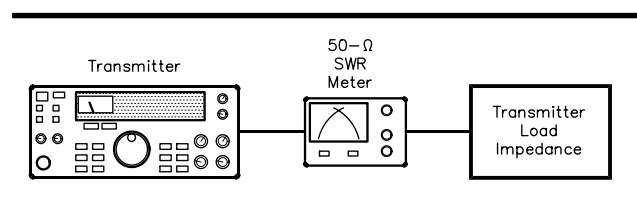
This chapter was written by [Frank Witt, AI1H](#), who has written numerous articles in *QST* and in *The ARRL Antenna Compendium* series on this subject. See the Bibliography for details.

The term *broadband antennas* has frequently been used to describe antenna systems that provide a wideband impedance match to the transmitter. This is something of a misnomer, since most antennas are good radiators over a wide range of frequencies and are therefore “broadband antennas” by definition. The problem is getting the energy to the antenna so it can be radiated. Antenna tuners solve this problem in some cases, although losses in transmission lines, baluns and the antenna tuner itself can be excessive. Also worthy of mention is that antenna directional properties are usually frequency dependent. In this chapter, we discuss broadbanding the impedance match to the transmitter only.

## GENERAL CONCEPTS

### The Objective

**Fig 1** shows a simplified system: the transmitter, an SWR meter and the transmitter load impedance. Modern transceivers are designed to operate properly into a 50-Ω



**Fig 1—Basic antenna system elements at the output of a transmitter.**

load and they will deliver full power into the load impedance, at their rated level of distortion, when the SWR is less than about 1.5:1. Loads beyond this limit may cause the transceiver to protect itself by lowering the output power.

Many transceivers have built-in automatic antenna tuners that permit operation for loads outside the 1.5:1 SWR range, but the matching range is often limited, particularly on the lower-frequency bands. In practice, barefoot operation is simplified if the load SWR is held to less than 2:1.

For high-power amplifiers, it is also best to keep the load SWR to less than about 2:1, since output tuning components are commonly rated to handle such loads. You can see that the primary function of the SWR meter in Fig 1 is to measure the suitability of the load impedance so far as the transmitter is concerned. Henceforth, we will use the term *load SWR* as a description of the transmitter’s load.

The SWR meter is actually reading a circuit condition at a single point in the system. In fact, the meter really measures magnitude of the reflection coefficient, but is calibrated in SWR. The relationships between the complex load impedance,  $Z_L$ , the magnitude of the reflection coefficient,  $|\rho|$ , and the load SWR are as follows:

$$|\rho| = \left| \frac{Z_L - 50}{Z_L + 50} \right| \quad (\text{Eq 1})$$

$$\text{SWR} = \frac{1 + |\rho|}{1 - |\rho|} \quad (\text{Eq 2})$$

where 50 Ω is used as the reference impedance, since the design load impedance for the transmitter is assumed to be 50 Ω.

An important point is that you need not know the output impedance of the transmitter to design a broadband matching network. The issue of the actual value of the output impedance of typical RF power amplifiers is a matter of continuing controversy in amateur circles. Fortunately, this issue is not important for the design of broadband matching networks, since the load SWR is independent of the output impedance of the transmitter. Our objective is to design the matching network so that the load SWR (with a 50-Ω reference resistance) is less than some value, say 2:1, over as wide a band as possible.

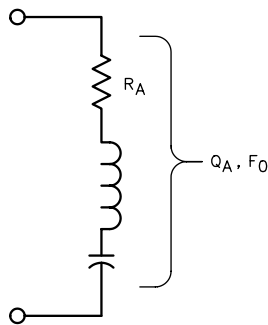


## Resonant Antennas

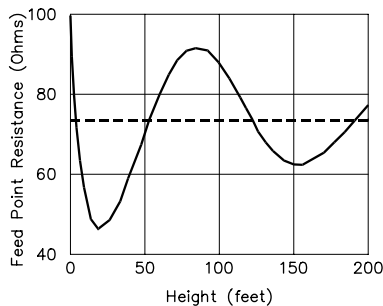
The broadband matching techniques described here apply to antennas operating near resonance. Typical resonant antennas include half-wave dipoles, quarter-wave verticals over a ground plane and full-wave loops. To design a broadband matching network, you must know the antenna feed-point impedance near resonance. **Fig 2** shows the antenna-impedance equivalent circuit near resonance. Although the series RLC circuit is an approximation, it is good enough to allow us to design matching networks that significantly increase the band over which a good match to the transmitter is achieved.

Note that the impedance is defined by  $F_0$ , the resonant frequency,  $R_A$ , the antenna resistance at resonance, and  $Q_A$ , the antenna Q.  $R_A$  is actually the sum of the radiation resistance and any loss resistance, including conductor losses and losses induced by surrounding objects, such as the ground below the antenna.  $R_A$  is frequency dependent, but it is sufficient to assume it is fixed during the matching network design process. Minor adjustments to the matching network will correct for the frequency dependence of  $R_A$ .

The antenna resistance and Q depend on the physical



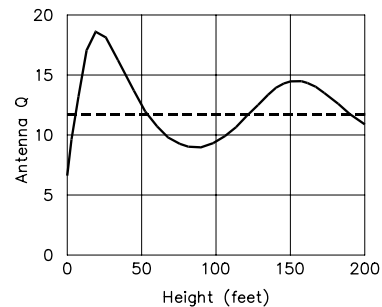
**Fig 2—The equivalent circuit of a resonant antenna. The simple series RLC approximation applies to many resonant antenna types, such as dipoles, monopoles, and loops.  $R_A$ ,  $Q_A$  and  $F_0$  are properties of the entire antenna, as discussed in the text.**



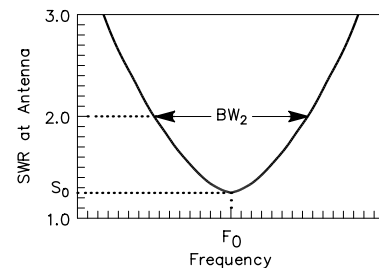
**Fig 3—Feed-point resistance (solid line) for 80-meter horizontal dipole at resonance versus height over ground. The free-space value is shown as a dashed line.**

properties of the antenna itself, the properties of ground and the height above ground. Consider as an example an 80-meter horizontal half-wave dipole made from #12 wire located over average ground (dielectric constant = 13 and conductivity = 5 mS/m). **Figs 3** and **4** show how feed-point resistance and Q vary with height. It is clear from these figures that there are wide gyrations in antenna parameters. The better these parameters are known, the more successful we will be at designing the broadband matching network. For horizontal dipoles, Figs 3 and 4 may be used to get a good idea of antenna resistance and Q, so long as the height is scaled in proportion to wavelength. For example, a 160-meter dipole at a height of 100 feet would have about the same resistance and Q as an 80-meter dipole at 50 feet.

For optimum results, the resistance and Q can be determined from computer simulation (using a program like *EZNEC*, for example) or measurement (using a low power SWR/Z meter such as the MFJ-259B or the Autek Research VA1 or RF-1).  $R_A$  can also be computed using SWR measurements at resonance. **Fig 5** shows the typical bowl-shaped SWR curve as a function of frequency for a resonant antenna.  $S_0$  is the SWR at resonance. You must take into account the loss of the feed line if the measurement must be made at the end of a long 50- $\Omega$  transmission line. If the line loss is low or if the measurement is made at the antenna terminals, the formulas given below apply.



**Fig 4—Antenna Q for 80-meter horizontal dipole (solid line) versus height. The free-space value is shown as a dashed line.**



**Fig 5—SWR at the antenna versus frequency in the vicinity of resonance.**

For  $R_A > 50 \Omega$

$$R_A = S_0 \times 50 \quad (\text{Eq 3})$$

For  $R_A < 50 \Omega$

$$R_A = \frac{50}{S_0} \quad (\text{Eq 4})$$

There is an ambiguity, since we do not know if  $R_A$  is greater than or less than  $50 \Omega$ . A simple way of resolving this ambiguity is to take the same SWR measurement at resonance with a  $10\text{-}\Omega$  non-inductive resistor added in series with the antenna impedance. If the SWR goes up,  $R_A > 45 \Omega$ . If the SWR goes down,  $R_A < 45 \Omega$ . This will resolve the ambiguity.

$Q_A$  may be determined by measuring the SWR bandwidth. Define  $BW_2$  as the bandwidth over which the resonant antenna SWR is less than 2:1 (in the same units as  $F_0$ ). See Fig 5.

For  $R_A > 50 \Omega$

$$Q_A = \frac{F_0}{BW_2} \sqrt{2.5 S_0 - S_0^2 - 1} \quad (\text{Eq 5})$$

For  $R_A < 50 \Omega$

$$Q_A = \frac{F_0}{BW_2 \times S_0} \sqrt{2.5 S_0 - S_0^2 - 1} \quad (\text{Eq 6})$$

Again, you must take into account the loss of the feed line if you make the measurement at the end of a long  $50\text{-}\Omega$  transmission line.

For horizontal and inverted-V half-wave dipoles, a very good approximation for the antenna  $Q$  when  $R_A$  is known is given by:

$$Q_A = \frac{93.9 \left[ \ln \frac{8110}{D F_0} - 1 \right]}{R_A} \quad (\text{Eq 7})$$

where  $D$  = the diameter of wire, in inches.

### Loss

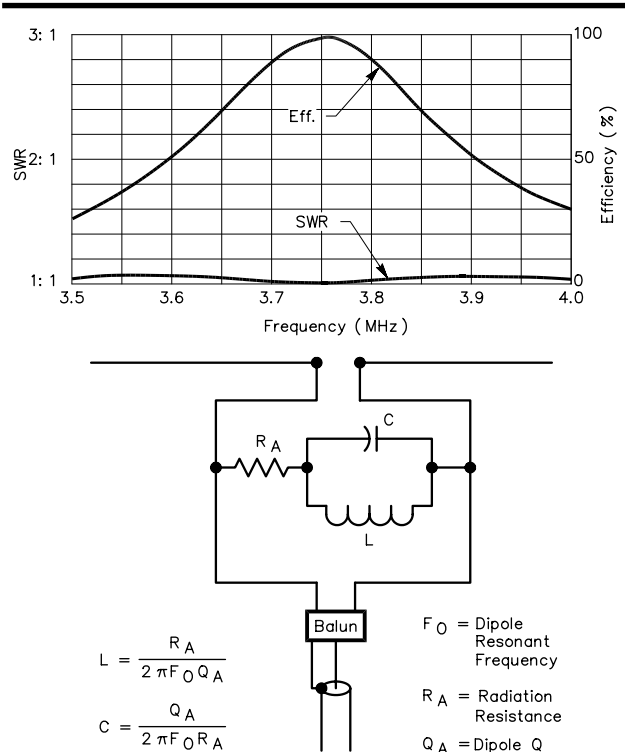
When you build a resonant antenna with some matching scheme designed to increase the bandwidth, you might overlook the loss introduced by the broadband matching components. Loss in dB is calculated from:

$$\text{Loss} = -10 \log \frac{\text{Power radiated by antenna}}{\text{Total power from transmitter}} \quad (\text{Eq 8})$$

or, alternatively, define efficiency in % as

$$\text{Efficiency} = \frac{100 \times \text{Power radiated by antenna}}{\text{Total power from transmitter}} \quad (\text{Eq 9})$$

An extreme degree of bandwidth broadening of an 80-meter dipole is illustrated in Fig 6. This approach is not recommended, but it is offered here to make a point. The broadening is accomplished by adding resistive losses. From network theory we obtain the RLC (resistor, inductor,



**Fig 6—Matching the dipole with a complementary RLC network greatly improves the SWR characteristics, nearly 1:1 across the 3.5-MHz band. However, the relative loss at the band edges is greater than 5 dB.**

capacitor) matching network shown. The network provides the complement of the antenna impedance. Note that the SWR is virtually 1:1 over the entire band (and beyond), but the efficiency falls off dramatically away from resonance.

The band-edge efficiency of 25 to 30% shown in Fig 6 means that the antenna has about 5 to 6 dB of loss relative to an ideal dipole. At the band edges, 70 to 75% of the power delivered down the transmission line from the transmitter is heating up the matching-network resistor. For a 1-kW output level, the resistor must have a power rating of at least 750 W! Use of an RLC complementary network for broadbanding is not recommended, but it does illustrate how resistance (or losses) in the matching network can significantly increase the apparent antenna SWR bandwidth.

The loss introduced by any broadband matching approach must be taken into consideration. Lossy matching networks will usually provide more match bandwidth improvement than less lossy ones.

## SIMPLE BROADBAND MATCHING TECHNIQUES

### The Cage Dipole

You can increase the match bandwidth of a single-wire dipole by using a thick radiator, one with a large diameter. The gain and radiation pattern are essentially the same as that of a thin-wire dipole. The radiator does not necessarily

have to be solid; open construction such as shown in **Fig 7** may be used.

The theoretical SWR response of an 80-meter cage dipole having a 6-inch diameter is shown in **Fig 8**.  $BW_2$  for this antenna fed with 50- $\Omega$  line is 287 kHz, and the Q is approximately 8. Its 2:1-SWR frequency range is 1.79 times broader than a dipole with a Q of 13, typical for thin-wire dipoles.

There are other means of creating a thick radiator, thereby gaining greater match bandwidth. The bow-tie and the fan dipole make use of the same Q-lowering principle as the cage for increased match bandwidth. The broadbanding techniques described below are usually more practical than the unwieldy cage dipole.

### Stagger-Tuned Dipoles

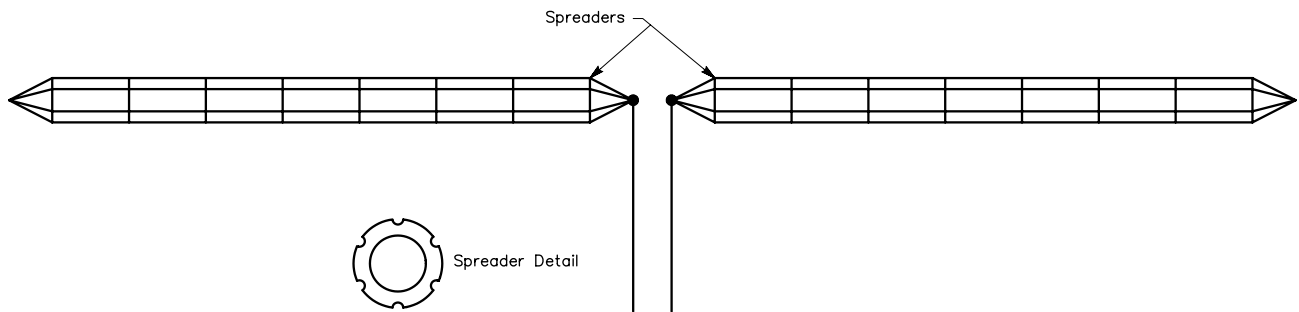
A single-wire dipole exhibits a relatively narrow bandwidth in terms of coverage for the 3.5 to 4.0-MHz band. A technique that has been used for years to cover the entire band is to use two dipoles, one cut for the CW portion and

one for the phone portion. The dipoles are connected in parallel at the feed point and use a single feeder. This technique is known as *stagger tuning*.

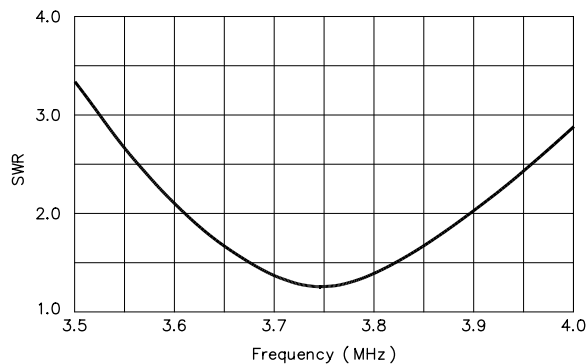
**Fig 9** shows a the theoretical SWR response of a pair of stagger-tuned dipoles fed with 50- $\Omega$  line. No mutual coupling between the wires is assumed, a condition that would exist if the two antennas were mounted at right angles to one another. As Fig 9 shows, the SWR response is less than 1.9:1 across the entire band.

A difficulty with such crossed dipoles is that four supports are required for horizontal antennas. A more common arrangement is to use inverted V dipoles with a single support, at the apex of each element. The radiator wires can also act as guy lines for the supporting mast.

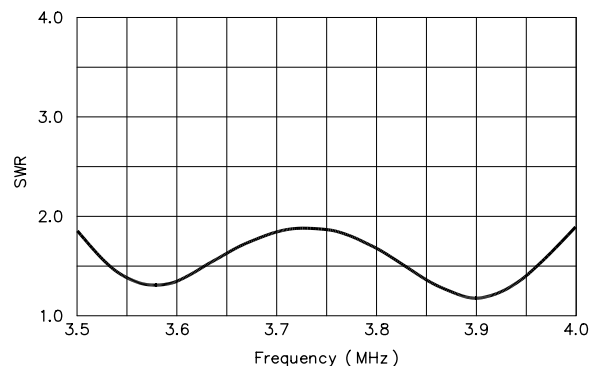
When the dipoles are mounted at something other than a right angle, mutual coupling between them comes into play. This causes interaction between the two elements—tuning of one by length adjustment will affect the tuning of the other. The interaction becomes most critical when the two dipoles are run parallel to each other, suspended by the same



**Fig 7**—Construction of a cage dipole, which has some resemblance to a round birdcage. The spreaders need not be of conductive material, and should be lightweight. Between adjacent conductors, the spacing should be  $0.02 \lambda$  or less. The number of spreaders and their spacing should be sufficient to maintain a relatively constant separation of the radiator wires.



**Fig 8**—Theoretical SWR versus frequency response for a cage dipole of length 122 feet 6 inches and a spreader diameter of 6 inches, fed with 50- $\Omega$  line. The 2:1-SWR bandwidth frequencies are 3.610 and 3.897 MHz, with a resulting  $BW_2$  of 287 kHz.



**Fig 9**—Theoretical SWR response of two stagger tuned dipoles. They are connected in parallel at the feed point and fed with 50- $\Omega$  line. The dipoles are of wire such as #12 or #14, with total lengths of 119 and 132 feet.

supports, and the wires are close together. Finding the optimum length for each dipole for total band coverage can become a tedious and frustrating process.

### Stagger-Tuned Radials

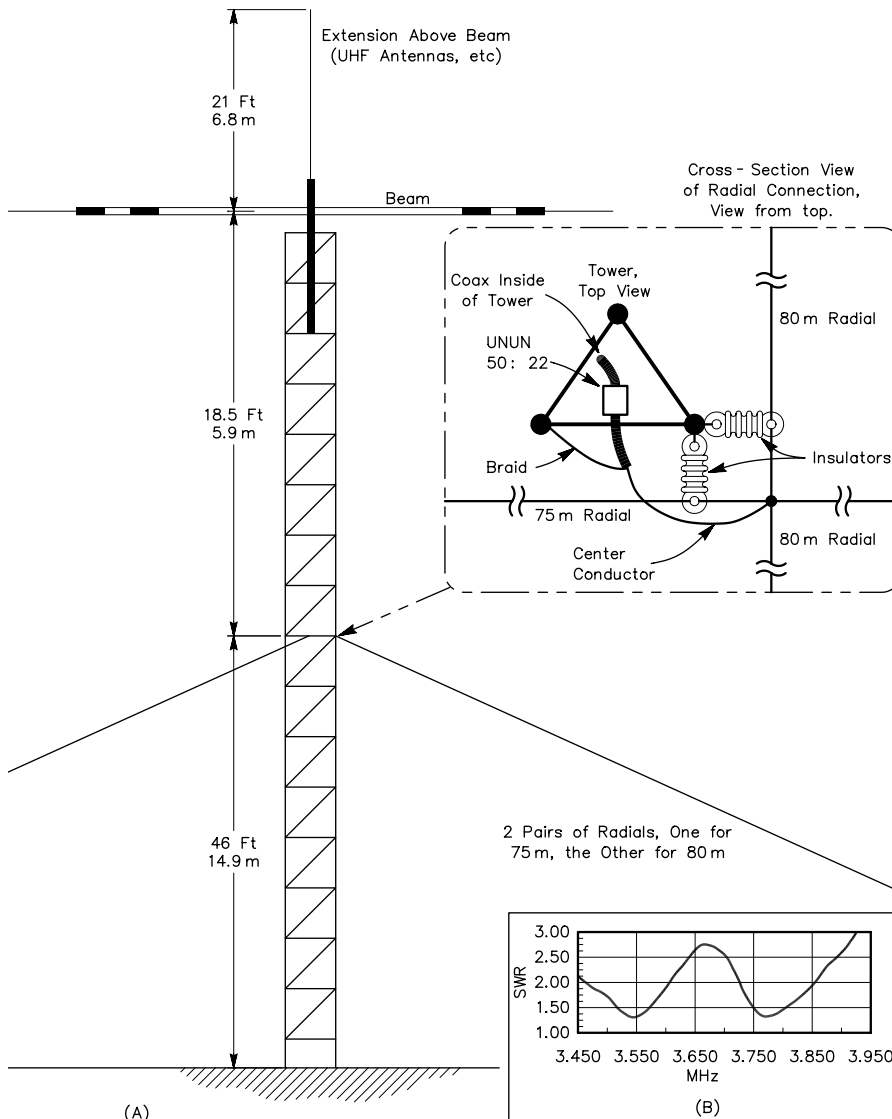
A variation of the use of stagger tuning has been applied by [Sam Leslie, W4PK](#). See his article entitled “Broadbanding the Elevated, Inverse-Fed Ground Plane Antenna” in *The ARRL Antenna Compendium Vol 6*. An existing tower with a large beam and VHF/UHF antennas on top is used as an 80-meter monopole. See **Fig 10A**. The feed point is part way up the tower, at a point where the metal above it makes up an electrical quarter wavelength. Four elevated quarter-wave radials are used as a ground plane. The radials droop away from the tower. They are joined together at the tower but not connected to the tower.

The antenna is fed with 50-Ω coax and an impedance step-down autotransformer (50:22 Ω unun) located at the tower. The shield of the coax is carried through the transformer and connected to the tower. The coax “hot side” is connected to the junction of the radials. A Q-section made from two paralleled RG-59 coax cables ( $Z_0 = 75/2 = 37.5 \Omega$ ) may be used instead of the autotransformer.

The broadband match is achieved by cutting two opposing radials for one end of the desired match range (75 meters) and cutting the other two for the other end of the range (80 meters). See Fig 10B for the resultant SWR versus frequency characteristic.

### FEED-LINE IMPEDANCE MISMATCHING

The simplest broadband matching network is a transformer at the junction of the transmission line and the



**Fig 10—At A, details of the inverse-fed ground-plane at W4PK. The inset shows the feed-point details. Keep the two sets of radials as close to 90° as possible. Don't try to resonate the antenna by adjusting radial lengths. At B, SWR curve of the inverse-fed ground plane antenna with stagger-tuned radials. The objective is to have a low SWR for both the CW and SSB 80/75-meter DX windows.**

antenna. See [Frank Witt](#)'s article entitled "Match Bandwidth of Resonant Antenna Systems" in October 1991 *QST*. Observe that the impedance of the series RLC resonant antenna model of [Fig 2](#) increases at frequencies away from resonance. The result is that more bandwidth is achieved when SWR at resonance is not exactly 1:1. For example, if the antenna is fed with a low-loss 50-Ω transmission line, the maximum SWR bandwidth is obtained if the effective  $R_A = 50/1.25 = 40 \Omega$ . The improvement in  $BW_2$ , the 2:1 SWR bandwidth, over a perfect match at resonance is only 6%, however. This condition of  $R_A = 40 \Omega$  can be achieved by installing a transformer at the junction of the feed line and the antenna.

If the line loss is larger, you can gain more benefit in terms of bandwidth by deliberately mismatching at the antenna. If the matched-line loss is 2 dB, the improvement rises to 18%. To achieve this requires an  $R_A = 28.2 \Omega$ . Again, the improvement over a perfect match at resonance is modest.

It is interesting to compare the 2:1 SWR bandwidth (at the transmitter end of the line) for the case of a lossless line versus the case of 2-dB matched-line loss.  $BW_2$  for the lossy line case is 1.95 times that of the lossless line case, so substantial match bandwidth improvement occurs, but at the cost of considerable loss. The band edge loss for the lossy-line case is 3 dB!

This example is provided mostly as a reference for comparison with the more desirable broadbanding techniques below. It also explains why some installations with long feed lines show large match bandwidths.

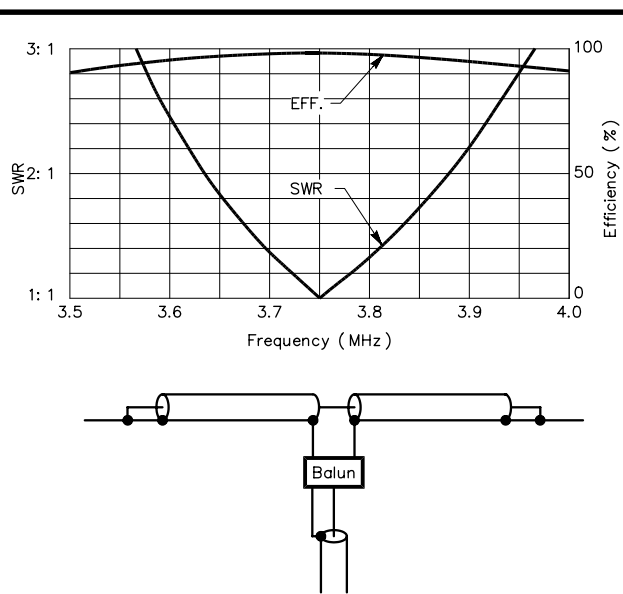
### PARALLEL-TUNED CIRCUITS AT THE ANTENNA TERMINALS

As mentioned previously, a resonant antenna has an equivalent circuit that may be represented as a series RLC circuit. We can cancel out some of the antenna reactance away from resonance with a parallel-tuned circuit connected across the antenna terminals. The impedance level of the parallel-tuned circuit must be low enough to be effective and must have the same resonant frequency as the antenna. You can use a parallel-tuned circuit made with lumped LC components or with transmission-line segments. A quarter-wave transmission line with a short at the far end, or a half-wave line with an open at the far end, each behave like a parallel-tuned LC circuit.

#### The Double Bazooka

The response of the controversial *double bazooka* antenna is shown in [Fig 11](#). This antenna actually consists of a dipole with two quarter-wave coaxial resonator stubs connected in series. The stubs are connected across the antenna terminals.

Not much bandwidth enhancement is provided by this resonator connection because the impedance of the matching network is too high. The antenna offers a 2:1-SWR bandwidth frequency range that is only 1.14 times that of a simple dipole with the same feeder. And the bandwidth enhancement is partially due to the "fat" antenna wires



**Fig 11—The double bazooka, sometimes called a coaxial dipole. The antenna is self-resonant at 3.75 MHz. The resonator stubs are 43.23-foot lengths of RG-58A coax.**

composed mostly of the coax shield. No improvement in antenna gain or pattern over a thin-wire dipole can be expected from this antenna.

### The Crossed Double Bazooka

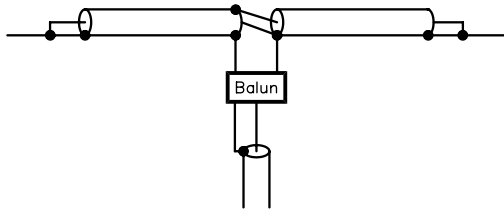
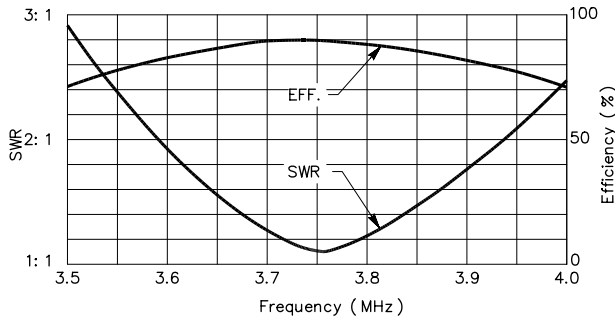
A modified version of the double-bazooka antenna is shown in [Fig 12](#). In this case, the impedance of the matching network is reduced to one-fourth of the impedance of the standard double-bazooka network. The lower impedance provides more reactance correction, and hence increases the bandwidth frequency range noticeably, to 1.55 times that of a simple dipole. Notice, however, that the efficiency of the antenna drops to about 80% at the 2:1-SWR points. This amounts to a loss of approximately 1 dB. The broadbanding, in part, is caused by the losses in the coaxial resonator stubs (made of RG-58A coax), which have a remarkably low Q (only 20).

## MATCHING NETWORK DESIGN

### Optimum Matching

You can improve the match bandwidth by using a transformer or a parallel-tuned circuit at the antenna terminals. A combination of these two techniques can yield a very effective match bandwidth enhancement. Again, you can make the impedance transformation and implement the tuned circuit using lumped-circuit elements (transformers, inductors and capacitors) or with distributed-circuit elements (transmission lines).

In 1950, an article by [R. M. Fano](#) presented the theory of broadband matching of arbitrary impedances. This classic work was limited to lossless matching networks.



**Fig 12**—The crossed double bazooka yields bandwidth improvement by using two quarter-wave resonators, parallel connected, as a matching network. As with the double bazooka, the resonator stubs are 43.23-foot lengths of RG-58A coax.

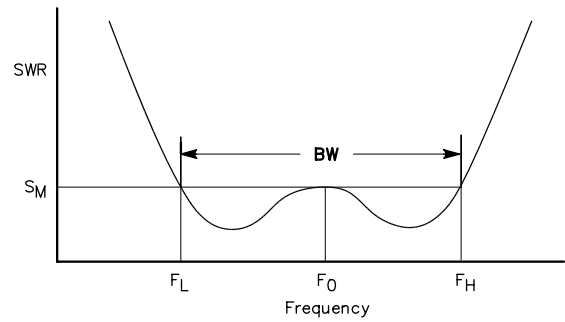
Unfortunately, matching networks realized with transmission lines have enough loss to render the Fano results useful as only a starting point in the design process. A theory of optimum matching with lossy matching networks was presented in an article by [Frank Witt](#) entitled “Optimum Lossy Broadband Matching Networks for Resonant Antennas” that appeared in April 1990 *RF Design* and was summarized and extended in “Broadband Matching with the Transmission Line Resonator,” in *The ARRL Antenna Compendium Vol 4*.

Using a matching network, the 2:1 SWR bandwidth can be increased by a factor of about 2.5. Instead of the familiar bowl-shaped SWR versus frequency characteristic seen in [Fig 5](#), the addition of the matching network yields the W-shaped characteristic of [Fig 13](#). The maximum SWR over the band is  $S_M$ . The band edges are  $F_L$  and  $F_H$ . Thus the bandwidth, BW, and the center frequency,  $F_0$ , are

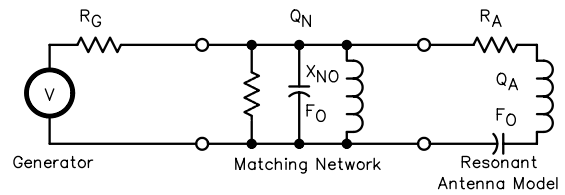
$$BW = F_H - F_L \quad (\text{Eq 10})$$

$$F_0 = \sqrt{F_H \times F_L} \quad (\text{Eq 11})$$

[Fig 14](#) shows the pertinent equivalent circuit for a typical broadband antenna system. The parallel LC matching network is defined by its resonant frequency,  $F_0$  (which is the same as the resonant frequency of the antenna), its Q and its impedance level. The impedance level is the reactance of either the matching network inductance or capacitance at  $F_0$ . The optimum transmitter load resistance,  $R_G$ , is achieved using an impedance transformer between the transmitter and the input to the parallel-tuned circuit. Thus for a transmitter whose optimum load resistance is



**Fig 13**—W-shaped SWR versus frequency characteristic that results when a transformer and parallel LC matching network are used.



**Fig 14**—Assumed equivalent circuit for the broadband matching system. The antenna and the matching network have the same resonant frequency.

50  $\Omega$ , the required impedance transformer would have an impedance transformation ratio of  $50:R_G$ .

The goal is to keep the SWR over the band as low as possible. There is a best or minimum value of  $S_M$  that may be achieved over the entire band. It depends on the desired match bandwidth and the  $Q$ s of the antenna and matching network and is given by the following formula:

$$S_{M\min} = \frac{\sqrt{B_N^2 + 1} + \sqrt{B_N^2 + 1 + \frac{2Q_A}{Q_N} \left(1 + \frac{Q_A}{2Q_N}\right)}}{2 \left(1 + \frac{Q_A}{2Q_N}\right)} \quad (\text{Eq 12})$$

where  $B_N = \frac{BW}{F_0}$  and

$Q_A$  = antenna Q

$Q_N$  = matching network Q.

The reactance at resonance of the parallel tuned LC matching network is given by:

$$X_{N0} = \frac{R_A}{Q_A} \left[ \left(1 + \frac{Q_A}{2Q_N}\right) S_{M\min}^2 - \frac{Q_A}{2Q_N} \right] \quad (\text{Eq 13})$$

where  $R_A$  = antenna resistance in  $\Omega$ .

The transmitter load resistance is calculated from:

$$R_G = \frac{S_{M \min} R_A Q_N X_{N0}}{R_A + Q_N X_{N0}} \quad (\text{Eq 14})$$

The loss of the matching network is always greatest at the edges of the band. This loss,  $L_{MNE}$ , in dB, is given by:

$$L_{MNE} = 10 \log \left[ 1 + \frac{R_A}{Q_N X_{N0}} (B_N^2 + 1) \right] \quad (\text{Eq 15})$$

Now you have all the information needed to design an optimal broadband matching network. An 80-meter dipole will serve as an example to illustrate the procedure. The following parameters are assumed:

- $F_L = 3.5 \text{ MHz}$
- $F_H = 4.0 \text{ MHz}$
- $R_A = 57.2 \ \Omega$
- $Q_A = 13$
- $Q_N = 40.65$

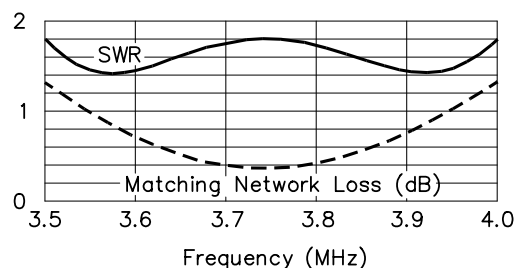
The values of  $R_A$  and  $Q_A$  are reasonable values for an 80-meter inverted V with an apex 60 feet above ground.  $Q_N = 40.65$  is the calculated value of the Q of a resonator made from RG-213 or similar cable in the middle of the 80-meter band. The results are:

- $BW = 0.5 \text{ MHz}$  (from Eq 10)
- $F_0 = 3.742 \text{ MHz}$  (from Eq 11)
- $S_{M \min} = 1.8$  (from Eq 12)
- $X_{N0} = 15.9 \ \Omega$  (from Eq 13)
- $R_G = 94.8 \ \Omega$  (from Eq 14)
- $L_{MNE} = 1.32 \text{ dB}$  (from Eq 15)

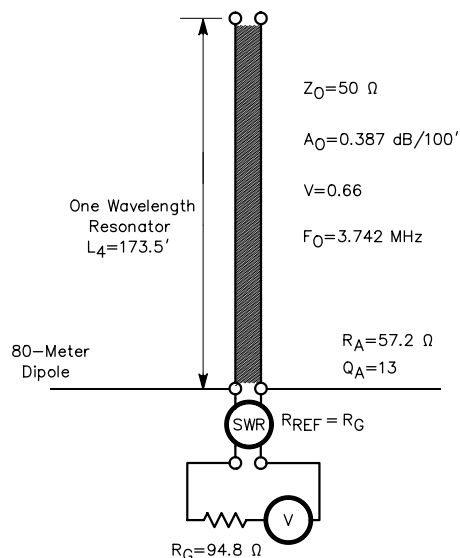
Shown in **Fig 15** is the plot of SWR and matching network loss versus frequency for this example. The reference resistance for the SWR calculation is  $R_G$  or  $94.8 \ \Omega$ . Since the desired load resistance for the transmitter is  $50 \ \Omega$ , we need some means to transform from  $94.8 \ \Omega$  to  $50 \ \Omega$ . The examples given in the rest of this chapter will show a variety of ways of achieving the necessary impedance transformation.

The meaning of  $X_{N0} = 15.9 \ \Omega$  is that the inductor and the capacitor in the matching network would each have a reactance of  $15.9 \ \Omega$  at  $3.742 \text{ MHz}$ . Methods for obtaining a particular value of  $X_{N0}$  are shown in the following examples as well. The particular value of  $X_{N0}$  of this example may be obtained with a one-wavelength resonator (open-circuited at the far end) made from RG-213. The system described in this example is shown in **Fig 16**.

The broadband antenna system shown in Fig 16 has a desirable SWR characteristic, but the feed line to the transmitter is not yet present. Fortunately, the same cable segment that makes up the resonator may be used as the feed line. A property of a feed line whose length is a multiple of  $\lambda/2$  (an even multiple of  $\lambda/4$ ) is that its input impedance is a near replica of the impedance at the far end. This is exactly true for lossless lines at the frequencies where the  $\lambda/2$  condition is true. Fortunately, practical lines have



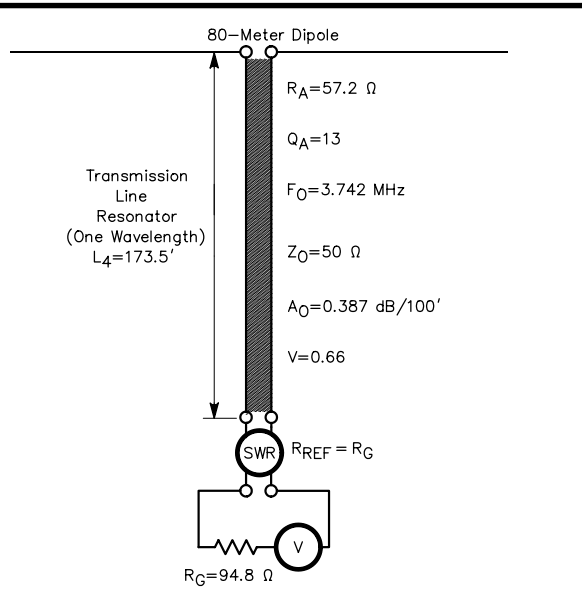
**Fig 15—SWR and matching network loss for example. Note that  $S_M$  is exactly 1.8 and the band-edge loss is exactly 1.32 dB, as calculated.**



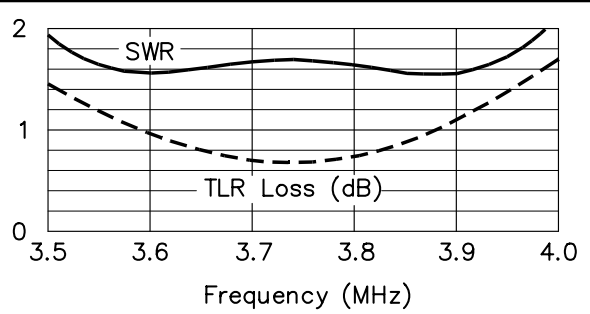
**Fig 16—80-meter dipole example with a  $1 \lambda$  resonator as the matching network.**

low-enough loss that the property mentioned above is true at the resonant frequency. Off resonance, the desired reactance cancellation we are looking for from the resonant line takes place. The very same design equations apply.

In **Fig 17**, the antenna shown in Fig 16 is moved to the far end of the  $1 \lambda$  resonator. The SWR and loss for this case are shown in **Fig 18**, which should be compared with Fig 15. The SWR is only slightly degraded, but the loss is about the same at the band edges. We have picked up a feed line that is  $1 \lambda$  long (173.5 feet) and broadband matching. You can make the SWR curve virtually the same as that of Fig 15 if the transmitter load resistance is increased from  $94.8 \ \Omega$  to  $102 \ \Omega$ . From a practical point of view, this degree of design refinement is unnecessary, but is instructive to know how the SWR characteristic may be controlled. You may apply the same approach when the resonator is an odd multiple of a wavelength, but in that case the transmitter or antenna must be connected  $\lambda/4$  from the shorted end.



**Fig 17**—The antenna is at the far end of the 1 λ line. The line does double duty—broadband matching and signal transport.



**Fig 18**—SWR and loss for a 1 λ 50-Ω feed line. The antenna system model is the one shown in Fig 17.

### Chebyshev Matching

Although it is not as efficient from the standpoint of bandwidth improvement and loss, Chebyshev matching is useful for some purposes. This arrangement yields a transmitter load impedance of  $50 + j0 \Omega$  at two frequencies in the band. The matching network circuit is the same as the optimum matching case, but the parameters are different. In this case, we assume that the antenna parameters,  $F_0$ ,  $R_A$  and  $Q_A$ , the network  $Q$  and the maximum SWR over the band are specified. The bandwidth, impedance level and generator resistance are given by:

$$BW = \frac{F_0}{Q_A Q_N} \left\{ \frac{[(Q_A + Q_N) [(Q_A + 2Q_N) S_M - Q_A] (S_M - 1)]}{S_M} \right\}^{\frac{1}{2}} \quad (\text{Eq 16})$$

$$X_{N0} = \frac{R_A}{Q_A} \left[ S_M + \frac{Q_A}{Q_N} (S_M - 1) \right] \quad (\text{Eq 17})$$

$$R_G = R_A \left( S_M - \frac{Q_A}{Q_A + Q_N} \right) \quad (\text{Eq 18})$$

The loss at the band edges is given by Eq 15. The frequencies where the transmitter load is  $50 + j0 \Omega$ ,  $F_L$  and  $F_H$ , are given by:

$$F_L = \sqrt{F_0^2 + F_M^2} - F_M \quad (\text{Eq 19})$$

where

$$F_M = \frac{F_0}{2Q_A} \left[ (S_M - 1) \left( 1 + \frac{Q_A}{Q_N} \right) \right]^{\frac{1}{2}} \quad (\text{Eq 20})$$

$$F_H = \frac{F_0^2}{F_L} \quad (\text{Eq 21})$$

### LC-MATCHING NETWORKS

Before the theory of optimal matching above was developed, Frank Witt, AI1H, described in his article “Broadband Dipoles—Some New Insights” in October 1986 *QST* the basic principle and some applications of LC matching networks. Fig 19 shows an LC matching network that is a modified version of one originally proposed by Alan Bloom, N1AL. Note that the basic ingredients are present: the parallel-tuned circuit for reactance cancellation and a transformer.

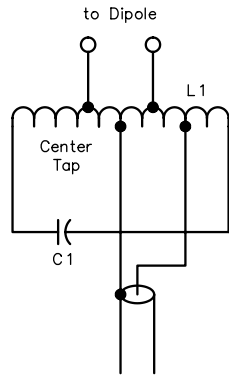
The network also functions as a voltage balun by connecting the shield of the coaxial feed line to the center tap of the inductor. The capacitor is connected across the entire coil to obtain practical element values. The SWR response and efficiency offered by a network of lumped components is shown in Fig 20. The 2:1-SWR bandwidth with 50-Ω line is 460 kHz. The design is a Chebyshev match, where SWR = 1:1 is achieved at two frequencies. For the same configuration, more match bandwidth and less loss could have been realized if the optimal-match theory had been applied.

The efficiency at the band edges for the antenna system shown in Fig 20 is 90% (Loss = 0.5 dB). This low loss is due to the high  $Q$  of the LC matching network ( $Q_N \approx 200$ ). The very low-impedance level required ( $X_{N0} = 12.4 \Omega$ ) cannot be easily realized with practical inductor-capacitor values. It is for this reason that the coil is tapped and serves as an autotransformer with multiple taps. The required impedance transformation ratio of 1:2.8 is easily achieved with this arrangement.

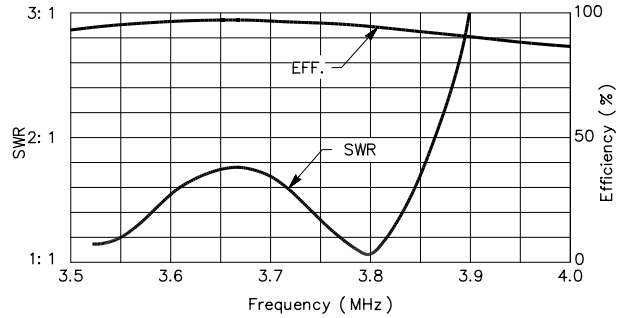
### 80-Meter DXer’s Delight

A version of an antenna system with an LC broadbanding network is dubbed the *80-meter DXer’s Delight*. This antenna has SWR minima near 3.5 and

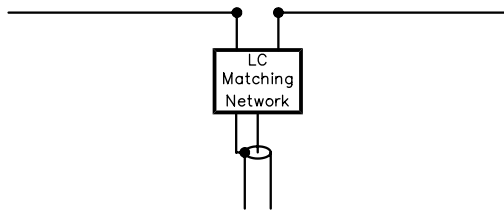
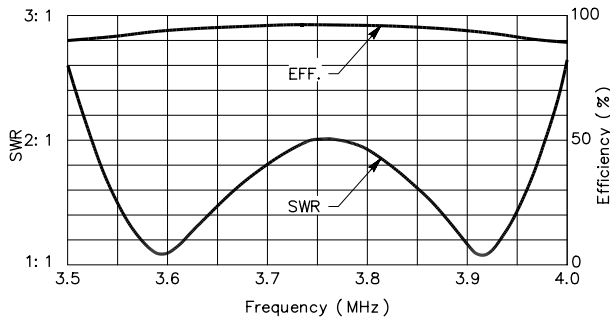




**Fig 19**—A practical LC matching network that provides reactance compensation, impedance transformation and balun action.



**Fig 21**—The 80-meter DXer's Delight permits operation with a 50- $\Omega$  transmitter load in the DX portions of the band, both CW and phone. This network was designed to provide a broadband match for an inverted V with  $F_0 = 3.67$  MHz, an antenna resistance of 60  $\Omega$  and a Q of 13. The matching network has an impedance level of 9  $\Omega$ , and a Q of 220. The feed line is 50- $\Omega$  coax, and the matching network provides an impedance step-up ratio of 2.0:1.

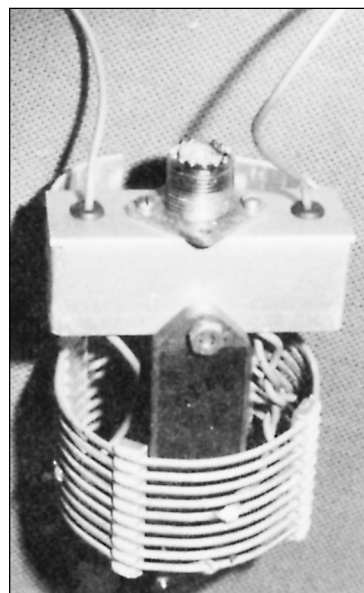


**Fig 20**—Efficient broadband matching with an lumped element LC network. The antenna in this example has a resistance of 72  $\Omega$  and a Q of 12. The matching network has an impedance level of 12.4  $\Omega$ , and a Q of 200. The feed line is 50- $\Omega$  coax, and the matching network provides an impedance step-up ratio of 2.8:1.

3.8 MHz. A single antenna permits operation with a transmitter load impedance of about 50  $\Omega$  in the DX portions of the band, both CW and phone. The efficiency and SWR characteristic are shown in **Fig 21**.

**Fig 22** shows the method of construction. The selection of a capacitor for this application must be made carefully, especially if high power is to be used. For the capacitor described in the caption of Fig 22, the allowable peak power (limited by the breakdown voltage) is 2450 W. However, the allowable average power (limited by the RF current rating of 4 A) is only 88 W! These limits apply at the 1.8:1 SWR points.

**Fig 22**—A method of constructing the LC broadband matching network. Components must be chosen for high Q and must have adequate voltage and current ratings. The network is designed for use at the antenna feed point, and should be housed in a weather-resistant package.



The component values are as follows:  
**C1**—400 pF transmitting mica rated at 3000 V, 4 A (RF)  
**L1**—4.7  $\mu$ H, 8 $\frac{1}{2}$  turns of B&W coil stock, type 3029 (6 turns per in., 2 $\frac{1}{2}$ -in. dia, #12 wire). The LC circuit is brought to midband resonance by adjusting an end tap on the inductor. The primary and secondary portions of the coil have 1 $\frac{3}{4}$  and 2 $\frac{1}{2}$  turns, respectively.

## PROPERTIES OF TRANSMISSION-LINE RESONATORS

One way around the power limitations of LC broadband matching networks is to use a transmission line as the resonator. Transmission line resonators, TLRs, typically have higher power-handling capability because the losses, though higher, are distributed over the length of the line instead of being concentrated in the lumped-LC components. Transmission-line resonators must be multiples of a quarter wavelength. For a parallel-tuned circuit, the odd-multiple  $\lambda/4$  lines must be shorted at the far end and the even-multiple

$\lambda/4$  lines must be open circuited.

The length of the matching network resonator is  $n$  electrical quarter wavelengths. The impedance level,  $Q$ , and line length are given by:

$$X_{N0} = \frac{4Z_0}{n\pi}$$

or, solving for  $Z_0$ ,

$$Z_0 = \frac{n\pi X_{N0}}{4} \quad (\text{Eq 22})$$

$$Q_N = \frac{2.774F_0}{A_0 V} \quad (\text{Eq 23})$$

$$L_N = \frac{245.9 n V}{F_0} \quad (\text{Eq 24})$$

where  $Z_0$  = line characteristic impedance in  $\Omega$   
 $A_0$  = matched line loss in dB per 100 feet  
 $V$  = velocity factor, and  
 $L_N$  = line length in feet.

These equations may be used to find the properties of the transmission line resonator in the systems shown in Figs 16 and 17. The line is RG-213 with the following properties:

$Z_0 = 50 \Omega$   
 $V = 0.66$   
 $A_0 = 0.4 \text{ dB}/100 \text{ feet at } 4 \text{ MHz}$

We need the matched loss at 3.742 MHz. Since the line loss is approximately proportional to  $\sqrt{\text{frequency}}$ ,

$$A_{0F2} = A_{0F1} \sqrt{\frac{F_2}{F_1}} \quad (\text{Eq 25})$$

where  $A_{0F1}$  and  $A_{0F2}$  are the matched line losses at frequencies  $F_1$  and  $F_2$ , respectively. Hence,

$A_0 = 0.387 \text{ dB}/100 \text{ feet at } 3.742 \text{ MHz}$   
 $Q_N = 40.65$  (from Eq 23)

This is the  $Q$  of any resonator made from RG-213 for a frequency of 3.742 MHz. It does not matter how many quarter wavelengths ( $n$ ) make up the cable segment. Earlier we calculated that the required impedance level,  $X_{N0}$ , is  $15.9 \Omega$ . Therefore, the required impedance level is:

$$Z_0 = \frac{n\pi \times 15.9}{4} = 12.5 n, \Omega \quad (\text{from Eq 22})$$

This means that you could use a quarter-wavelength segment with a short at the far end if  $Z_0 = 12.5 \Omega$ , or a half-wavelength segment with an open at the far end if  $Z_0 = 25 \Omega$ . Our example used an open-circuited full-wavelength resonator ( $n = 4$ ) with a  $Z_0$  of  $50 \Omega$ . This example was crafted to make this happen (so that it fits RG-213 properties), but it illustrates that some juggling is required to obtain the right resonator properties when it is made from a transmission line, since we are stuck with the cable's characteristic impedance.

## The TLR Transformer

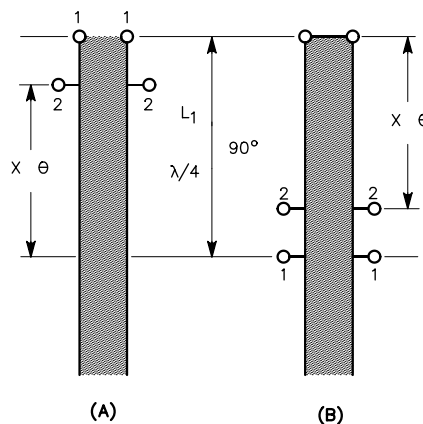
A way around the limitation created by available characteristic impedance values is to use the *transmission-line resonator transformer*. The basic idea is to make the connection to the TLR at an intermediate point along the line instead of at the end of the line. It is analogous to using taps on a parallel-tuned LC resonant circuit to achieve transformer action (See Fig 19). The nature of the transformer action is seen in Fig 23, where the ends of the transformer are designated 1-1 and 2-2. The impedance ratio of the transformer,  $N_Z$ , is approximated by

$$N_Z = \sin^2 \theta \quad (\text{Eq 26})$$

The distance in feet,  $x$ , is given by

$$x = \frac{\theta}{90} \times \frac{\lambda}{4} = \frac{\theta}{90} \times \frac{245.9 V}{F_0} \quad (\text{Eq 27})$$

This approach may be used for the connection of the TLR to the transmitter or to the antenna or both. An example will help make the power of the TLR transformer clear. We want to broadband match an 80-meter dipole (where  $F_0$  is 3.742 MHz,  $R_A$  is  $65 \Omega$  and  $Q_A$  is 13). The feed line is RG-213  $50\text{-}\Omega$  cable, and the total distance between the antenna and transmitter is less than 100 feet.



**Fig 23—Transformer action in the TLR. The definition of transformer terminals depends on whether the TLR end is open- or short-circuited.  $\theta$  is the distance between the minimum of the voltage standing wave (at resonance) and the connection point, expressed as an electrical angle. The distance  $x$  is that same distance expressed in feet.**

Since we know that  $Z_0 = 50 \Omega$ , we will design a prototype system with a  $3/4 \lambda$  TLR ( $n=3$ ). Since  $n$  is odd, the TLR must be shorted at one end, and we will place the short at the transmitter end of the line. The intermediate step of using a prototype system will enable us to design a system with the final TLR, but without transformer action. Then we'll calculate the proper connection points along the TLR. **Fig 24** shows the prototype system and the system with built-in transformers.

Note that the prototype antenna is connected to the open end of the TLR. The prototype generator (transmitter) is connected at a multiple of  $\lambda/2$  from the antenna. Here, at resonance, an approximate replica of the antenna will appear. We will use primed variables to indicate prototype antenna system elements. The prototype antenna differs from the actual antenna in impedance level, so only  $R_A$  will change.  $F_0$  and  $Q_A$  remain the same.

Starting with the  $3/4 \lambda$  TLR, we have:

$$X_{N0} = 21.2 \Omega \quad (\text{from Eq 22})$$

The prototype antenna resistance at resonance,  $R'_A$ , is calculated by rearranging [Eq 13](#).

$$R'_A = \frac{X_{N0} Q_A}{\left(1 + \frac{Q_A}{2Q_N}\right) S_{M \min}^2 - \frac{Q_A}{2Q_N}} \quad (\text{Eq 28})$$

Earlier we calculated that  $Q_N = 40.65$  and  $S_{M \min} = 1.8$ . Now we find

$$R'_A = 76.3 \Omega \quad (\text{from Eq 28})$$

$$R'_G = 126.4 \Omega \quad (\text{from Eq 14})$$

The electrical angles (in degrees) and connection locations (in feet) are given by

$$\theta_A = \sin^{-1} \sqrt{\frac{R_A}{R'_A}} \quad (\text{Eq 29})$$

$$\theta_G = \sin^{-1} \sqrt{\frac{R_G}{R'_G}} \quad (\text{Eq 30})$$

$$x_A = \frac{\theta_A}{90} L_1 \quad (\text{Eq 31})$$

$$x_G = \frac{\theta_G}{90} L_1 \quad (\text{Eq 32})$$

$$\text{where } L_1 = \frac{\lambda}{4} = \frac{245.9 \text{ V}}{F_0}$$

The lengths of the stubs and link of [Fig 24](#) are given by

$$L_O = L_1 = x_A \quad (\text{Eq 33})$$

$$L_S = x_G \quad (\text{Eq 34})$$

$$L_L = 3L_1 - L_O - L_S \quad (\text{Eq 35})$$

Since  $L_1 = 43.4$  feet,

$$\theta_A = 67.4^\circ \quad (\text{from Eq 29})$$

$$\theta_G = 39.0^\circ \quad (\text{from Eq 30})$$

$$L_O = 10.9 \text{ feet} \quad (\text{from Eq 33})$$

$$L_S = 18.8 \text{ feet} \quad (\text{from Eq 34})$$

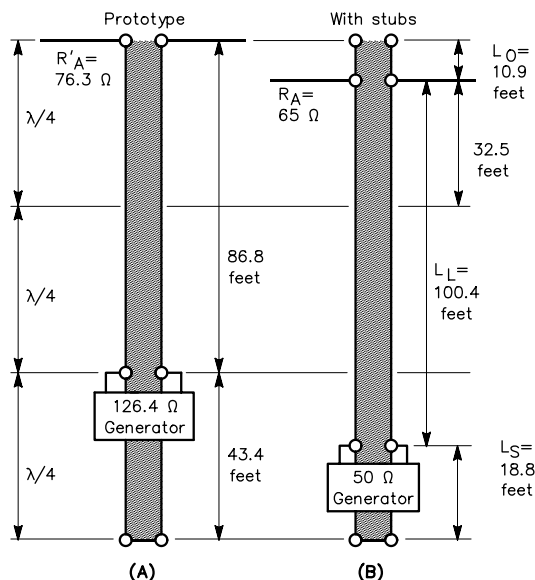
$$L_L = 100.4 \text{ feet} \quad (\text{from Eq 35})$$

These dimensions are summarized in [Fig 24](#). If required, additional 50- $\Omega$  cable may be added between the transmitter and the junction of the shorted stub and the link. A remarkable aspect of the TLR transformer, as demonstrated in this example, is that it is a transformer with multiple taps distributed over a great distance, in this case over 100 feet.

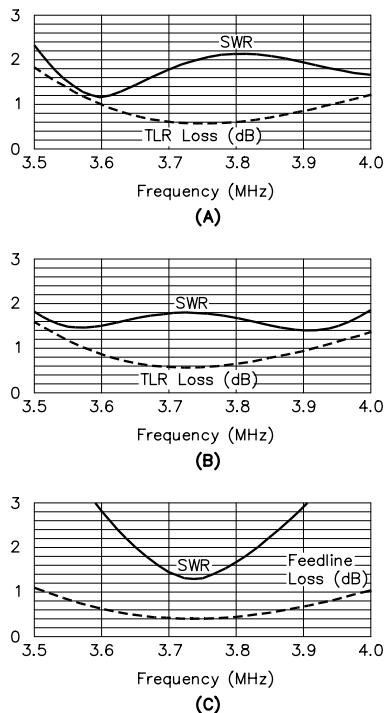
The calculated SWR and loss of the antenna system with the TLR transformer are shown in [Fig 25A](#). We mentioned earlier that the stub calculations are an approximation. [Fig 25](#) bears this out, but the changes necessary to achieve the optimized results are relatively small. By changing the lengths and dipole resonant frequency slightly, the target optimized SWR characteristic of [Fig 25B](#) results. See [Table 1](#) for a summary of the changes required.

To demonstrate the significant improvement in match bandwidth that the TLR transformer provides, the SWR and loss of the same dipole fed with 100.4 feet of RG-213 cable is shown in [Fig 25C](#). The loss added by the two stubs used to obtain match bandwidth enhancement is negligible (0.2 to 0.5 dB)

A TLR transformer may be used by itself to achieve a low-loss narrow-band impedance transformation,



**Fig 24**—An optimized antenna system with a  $3/4 \lambda$  TLR made from RG-213 coaxial cable. The prototype system at **A** is a convenient intermediate step in the design process. At **B** is the configuration with TLR transformers. It has an open stub,  $L_O$ , a link,  $L_L$  (which serves as the feed line), and a shorted stub,  $L_S$ .



**Fig 25—The SWR and loss of the TLR transformer antenna system. At A, the results are shown with the calculated line lengths. At B, the improvement after the lengths were optimized is shown in Table 1. At C, for comparison, SWR and loss for the same setup as at A, but with the stubs removed.**

**Table 1  
Calculated and Optimized Parameters Using TLR Transformers**

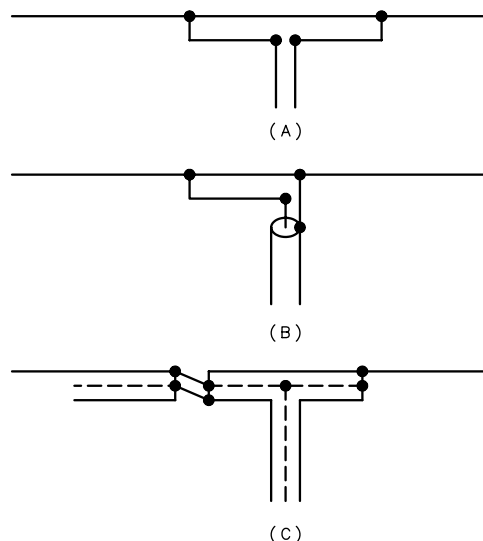
	<i>Calculated</i>	<i>Optimized</i>
Dipole resonant frequency ( $F_0$ )	3.742 MHz	3.710 MHz
Open stub ( $L_O$ )	10.9 feet	13.1 feet
Shorted stub ( $L_S$ )	18.8 feet	20.1 feet
Link ( $L_L$ )	100.4 feet	101.0 feet

functioning like a  $\lambda/4$  Q-section. It is different in nature from a Q-section, in that it is true impedance transformer, while a Q section is an *impedance inverter*. The TLR transformer may be designed into the antenna system and is a useful tool when a narrow-band impedance transformation is needed.

## TRANSMISSION-LINE RESONATORS AS PART OF THE ANTENNA

### The Coaxial-Resonator Match

This material is condensed from articles that appeared in April 1989 *QST* and *The ARRL Antenna Compendium Volume 2*. The coaxial-resonator match, a concept based on the TLR transformer, performs the same function as the



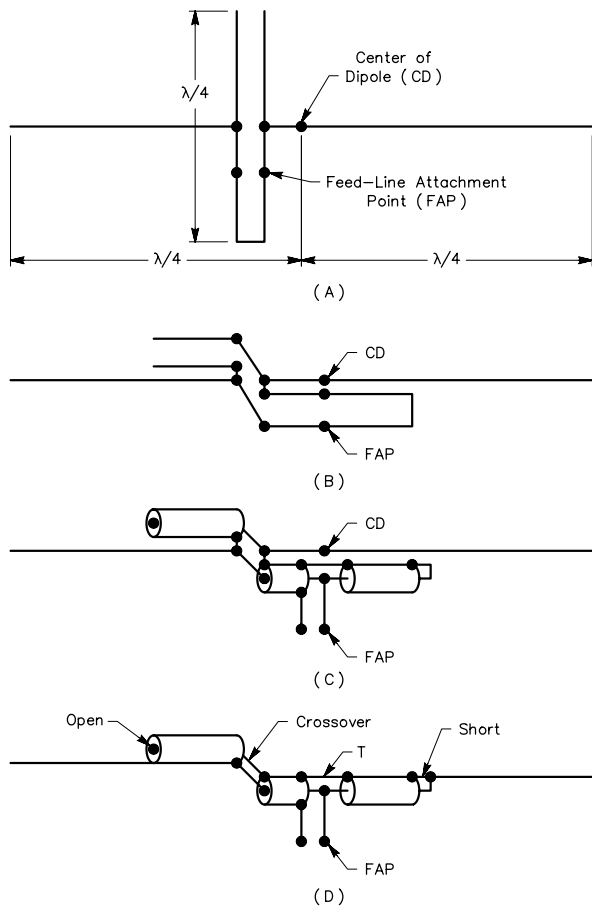
**Fig 26—Dipole matching methods. At A, the T match; at B, the gamma match; at C, the coaxial resonator match.**

T match and the gamma match, that is, matching a transmission line to a resonant dipole. These familiar matching devices as well as the coaxial resonator match are shown in **Fig 26**. The coaxial resonator match has some similarity to the gamma match in that it allows connection of the shield of the coaxial feed line to the center of the dipole, and it feeds the dipole off center. The coaxial resonator match has a further advantage: It can be used to broadband the antenna system while providing an impedance match.

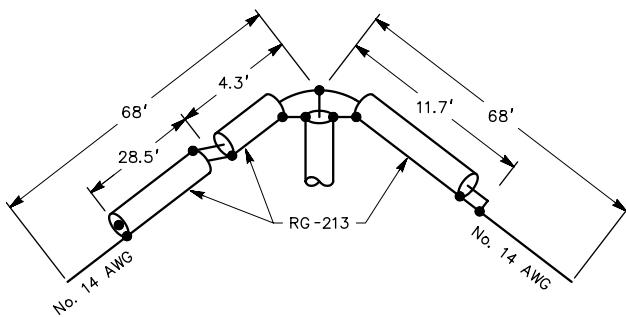
The coaxial resonator match is a resonant transformer made from a quarter-wave long piece of coaxial cable. **Fig 27** shows the evolution of the coaxial-resonator match. Now it becomes clear why coaxial cable is used for the quarter-wave TLR transformer—interaction between the dipole and the matching network is minimized. The effective dipole feed point is located at the crossover, which is an off-center feed point. In effect, the match is physically located “inside” the dipole. Currents flowing on the inside of the shield of the coax are associated with the resonator; currents flowing on the outside of the shield of the coax are the usual dipole currents. Skin effect provides a degree of isolation and allows the coax to perform its dual function. The wire extensions at each end make up the remainder of the dipole, making the overall length equal to one half-wavelength.

A useful feature of an antenna using the coaxial-resonator match is that the entire antenna is at the same dc potential as the feed-line potential, thereby avoiding charge buildup on the antenna. Hence, noise and the potential of lightning damage are reduced.

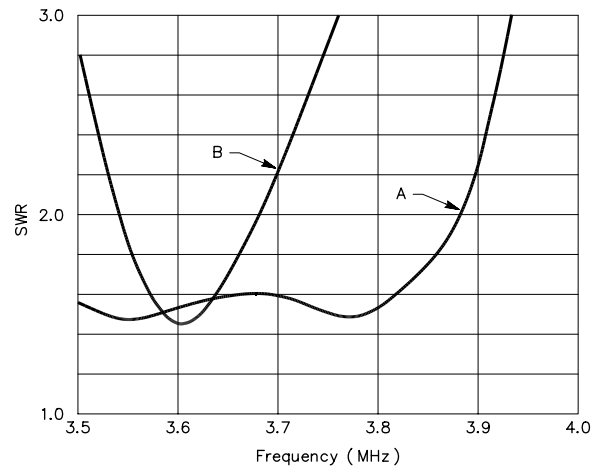
**Fig 28** shows the detailed dimensions of an 80-meter inverted-V dipole using a coaxial-resonator match. This design provides a load SWR better than 1.6:1 from 3.5 to 3.825 MHz and has been named the *80-Meter DX Special*.



**Fig 27—Evolution of the coaxial-resonator-match broadband dipole. At A, a TLR transformer is used to match the feed line to the off-center-fed dipole. The match and dipole are made collinear at B. At C, the balanced transmission-line TLR transformer of A and B is replaced by a coaxial version. Because the shield of the coax can serve as a part of the dipole radiator, the wire adjacent to the coax match may be eliminated, D.**



**Fig 28—Dimensions for the 80-Meter MHz DX Special, an antenna optimized for the phone and CW DX portions of the 3.5-MHz band. The coax segment lengths total to one quarter-wavelength. The overall length is the same as that of a conventional inverted V dipole.**



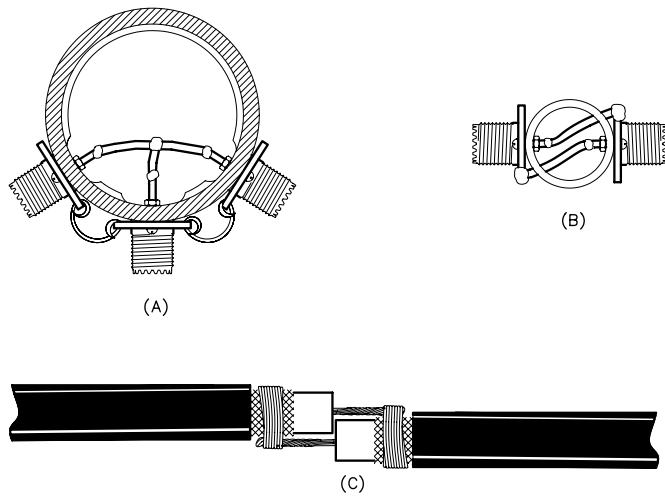
**Fig 29—Measured SWR performance of the 80-Meter DX Special, curve A. Note the substantial broadbanding relative to a conventional uncompensated dipole, curve B.**

The coax is an electrical quarter wavelength, has a short at one end, an open at the other end, a strategically placed crossover, and is fed at a T junction. (The crossover is made by connecting the shield of one coax segment to the center conductor of the adjacent segment and by connecting the remaining center conductor and shield in a similar way.) The antenna is constructed as an inverted-V dipole with a 110° included angle and an apex at 60 feet. The measured SWR versus frequency is shown in **Fig 29**. Also in **Fig 29** is the SWR characteristic for an uncompensated inverted-V dipole made from the same materials and positioned exactly like the broadband version.

The 80-Meter DX Special is made from RG-213 coaxial cable and #14 AWG wire, and is fed with 50-Ω coax. The coax forming the antenna should be cut so that the stub lengths of **Fig 28** are within 1/2 inch of the specified values. PVC plastic-pipe couplings and SO-239 UHF chassis connectors can be used to make the T and crossover connections, as shown in **Fig 30A** and **30B**. Alternatively, a standard UHF T connector and coupler can be used for the T, and the crossover may be a soldered connection (**Fig 30C**). RG-213 is used because of its ready availability, physical strength, power handling capability, and moderate loss.

Cut the wire ends of the dipole about three feet longer than the lengths given in **Fig 28**. If there is a tilt in the SWR-frequency curve when the antenna is first built, it may be flattened to look like the shape given in **Fig 29** by increasing or decreasing the wire length. Each end should be lengthened or shortened by the same amount.

*A word of caution:* If the coaxial cable chosen is not RG-8 or equivalent, the dimensions will have to be modified. The following cable types have about the same characteristic impedance, loss and velocity factor as RG-213 and could be substituted: RG-8, RG-8A, RG-10, RG-10A, RG-213 and



**Fig 30—T and crossover construction.** At A, a 2-inch PVC pipe coupling can be used for the T, and at B, a 1-inch coupling for the crossover. These sizes are the nominal inside diameters of the PVC pipe that is normally used with the couplings. The T could be made from standard UHF hardware (an M-358 T and a PL-258 coupler). An alternative construction for the crossover is shown at C, where a direct solder connection is made.

RG-215. If the Q of the dipole is particularly high or the radiation resistance is unusually low because of different ground characteristics, antenna height, surrounding objects and so on, then different segment lengths will be required.

What is the performance of this broadband antenna relative to that of a conventional inverted-V dipole? Aside from the slight loss (about 0.75 dB at band edges, less elsewhere) because of the non-ideal matching network, the broadband version will behave essentially the same as a dipole cut for the frequency of interest. That is, the radiation patterns for the two cases will be virtually the same.

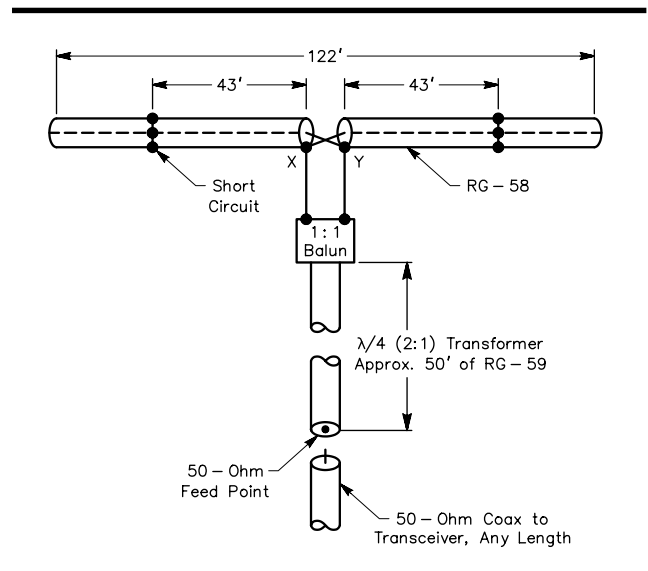
### The Snyder Dipole

A commercially manufactured antenna utilizing the principles described in the Matching Network Design section is the Snyder dipole. Patented by [Richard D. Snyder](#) in late 1984 (see Bibliography), it immediately received much public attention through an article that Snyder published. Snyder's claimed performance for the antenna is a 2:1 SWR bandwidth of 20% with high efficiency.

The configuration of the Snyder antenna is like that of the crossed-double bazooka of [Fig 12](#), with 25-Ω line used for the cross-connected resonators. In addition, the antenna is fed through a 2:1 balun, and exhibits a W-shaped SWR characteristic like that of [Fig 13](#). The SWR at band center, based on information in the patent document, is 1.7 to 1. There is some controversy in professional circles regarding the claims for the Snyder antenna.

### The Improved Crossed-Double Bazooka

The following has been condensed from an article by [Reed Fisher, W2CQH](#), that appeared in *The ARRL Antenna Compendium Volume 2*. The antenna is shown in [Fig 31](#). Note that the half-wave flat-top is constructed of sections of RG-58 coaxial cable. These sections of coaxial cable serve as quarter-wave shunt stubs that are essentially connected *in parallel* at the feed point in the crossed double-bazooka

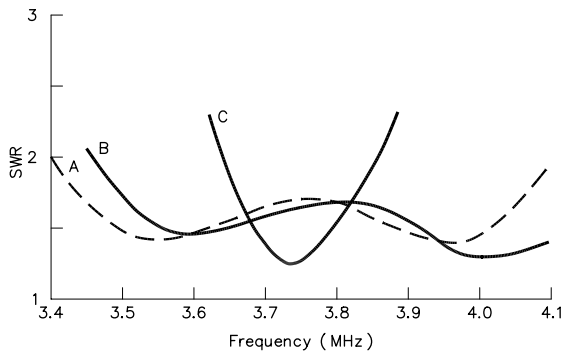


**Fig 31—Details of the W2CQH broadband-matched 80-meter dipole.**

fashion. At an electrical quarter wavelength (43 feet) from each side of the feed point X-Y, the center conductor is shorted to the braid of the coaxial cable.

The parallel stubs provide reactance compensation. The necessary impedance transformation at the antenna feed point is provided by the quarter-wave Q-section constructed of a 50-foot section of 75-Ω coaxial cable (RG-59). A W2DU 1:1 current balun is used at the feed point. See [Fig 32](#) for the SWR versus frequency for this antenna with and without the broadband matching network.

This antenna is essentially that of the crossed double bazooka antenna shown in [Fig 12](#), with the addition of the 75-Ω Q-section. The improvement in match bandwidth is substantial. The antenna at W2CQH is straight and nearly horizontal with an average height of about 30 feet.



**Fig 32—SWR curves for the improved double bazooka. Curve A, the theoretical curve with 50-Ω stubs and a  $\lambda/4$ , 75-Ω matching transformer. Curve B, measured response of the same antenna, built with RG-58 stubs and an RG-59 transformer. Curve C, measurements from a dipole without broadbanding. Measurements were made at W2CQH with the dipole horizontal at 30 feet.**

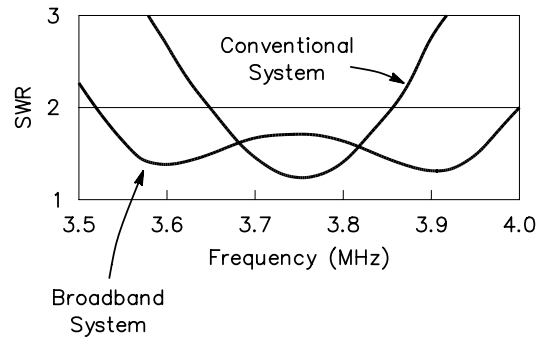
## TRANSMISSION-LINE RESONATORS AS PART OF THE FEED LINE

### A Simple Broadband Dipole for 80 Meters

This system was described in an article in September 1993 *QST*. It has the advantage that the radiator is the same as that of a conventional half-wave wire dipole. Thus the antenna is light weight, easy to support and has small wind and ice loading. The broadband matching network is integrated into the feed line.

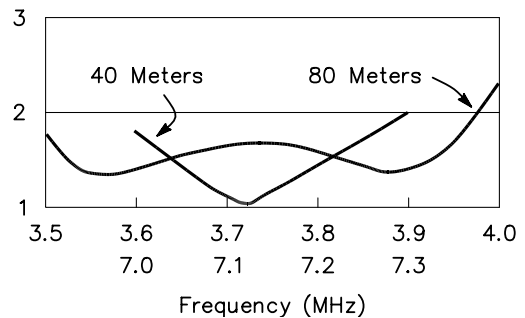
The system is shown in Fig 33. It is a variation of the example shown in the Matching Network Design section of this chapter as shown in Fig 17. The TLR is a  $1 \lambda$  length of RG-213 50-Ω coax and the impedance transformation is accomplished with a 75-Ω Q-section made of RG-11. The antenna is an inverted-V with a  $140^\circ$  included angle and an apex height of 60 feet. The wire size is #14, but is not critical. The balun is a W2DU 1:1 current type. It easily handles the legal power limit over the entire 80-meter band. The measured SWR is shown in Fig 34.

A unique advantage of this antenna is that by paralleling a 40-meter dipole at the feed point and sharing the feed line,

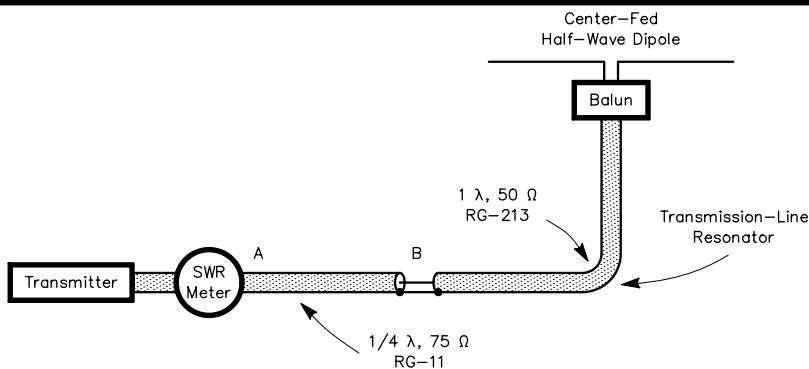


**Fig 34—Measured SWR versus frequency for the broadband and conventional antenna systems.**

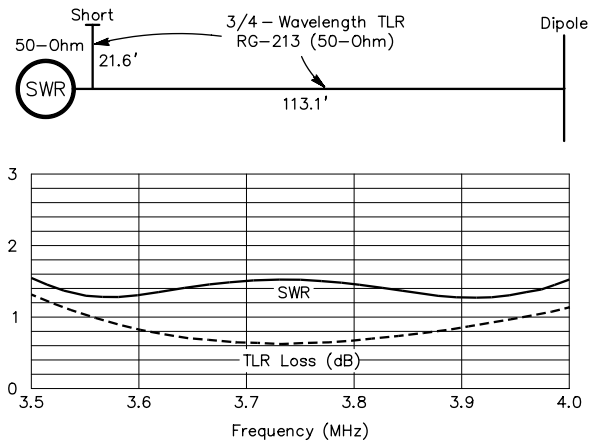
operation on both 80 and 40 meters is possible. The reason for this is that the lengths of the Q-section and the TLR are multiples of a half-wavelength on 40 meters. To minimize the interaction, the two dipoles should be spaced from each other away from the feed point. First tune the 80-meter antenna and then the 40-meter one. Fig 35 shows the result of adding a 40-meter dipole to the system shown in Fig 33. Each 40-meter dipole leg is 34.4 feet long. Note that the SWR on 80 meters changes very little compared to Fig 34. No change was made to the 80-meter dipole or to the transmission line.



**Fig 35—Measured SWR for the 80- and 40-meter multiband antenna system.**



**Fig 33—This simple broadband antenna system resembles a conventional 80-meter dipole except for the  $\lambda/4$ -wavelength 75-Ω segment. The lengths of the Q-section, TLR (including balun) and dipole are 43.3 feet, 170.5 feet, and 122.7 feet, respectively.**



**Fig 36—Broadbanding with the TLR transformer. The dimensions shown apply for an 80-meter horizontal dipole 80 feet above average ground. If the 21.6-foot shorted stub is removed, the impressive broadbanding disappears and the loss at 3.5 and 4.0 MHz drops a small amount to only 1 dB.**

### 80-Meter Dipole with the TLR Transformer

The total length of the feed line in the system just described above in Fig 33 is quite long, about 214 feet. For installations with shorter runs, the TLR transformer concept may be employed to advantage. An example provided in “Optimizing the 80-Meter Dipole” in *The ARRL Antenna Compendium Vol 4* is shown in Fig 36. Here the TLR is  $3/4 \lambda$  long overall and is made from RG-213 50- $\Omega$  cable. The design applies for an 80-meter horizontal dipole, 80 feet above average ground, with an assumed antenna  $F_0$ ,  $R_A$ , and  $Q_A$  of 3.72 MHz, 92  $\Omega$  and 9, respectively. (See Figs 3 and 4.) The lengths must be revised for other dipole parameters.

For this design, the feed line is 113.1 feet long and the shorted stub at the transmitter end is 21.6 feet long. You can add any length of 50- $\Omega$  cable between the transmitter and the junction of the shorted stub and the feed line. The shorted stub gives a dc path to ground for both sides of the dipole, preventing charge buildup and some lightning protection. For multiband operation with an antenna tuner, the stub should be removed.

The general application of the TLR transformer concept has a tap at both the transmitter end and a tap at the antenna end. (See Fig 24.) In this case, the concept was applied only at the transmitter end, since very little impedance transformation was required at the antenna end. The location of the TLR transformer is not obvious. Consider a  $3/4 \lambda$  TLR with a short at one end, and an open at the other end where the antenna is connected. The generator for no impedance transformation would be located  $\lambda/4$  (43.6 feet @ 3.72 MHz) from the short. By connecting the transmitter 21.6 feet from the short, the required impedance transformation for a transmitter optimized for 50- $\Omega$  loads is achieved.

## BIBLIOGRAPHY

Source material and more extended discussion of the topics covered in this chapter can be found in the references given below and in the textbooks listed at the end of Chapter 2.

- A. Bloom, “Once More with the 80-Meter Dipole,” *Technical Correspondence, QST*, Jun 1985, p 42.
- R. E. Fisher, “A Simple, Broadband 80-Meter Dipole Antenna,” *The ARRL Antenna Compendium Volume 2* (Newington, CT: ARRL, 1989), pp 119-123.
- R. M. Fano, “Theoretical Limitations on the Broadband Matching of Arbitrary Impedances,” *Journal of the Franklin Inst*, Jan 1950, pp 57-83, and Feb 1950, pp 139-155.
- J. Hall, “The Search for a Simple, Broadband 80-Meter Dipole,” *QST*, Apr 1983, pp 22-27.
- J. Hall, “Maxcom Antenna Matcher and Dipole Cable Kit,” *Product Review, QST*, Nov 1984, pp 53-54.
- R. C. Hansen, “Evaluation of the Snyder Dipole,” *IEEE Trans on Antennas and Prop*, Vol AP-35, No. 2, Feb 1987, pp 207-210.
- A. Harbach, “Broadband 80-Meter Antenna,” *QST*, Dec 1980, pp 36-37 (presentation of a cage antenna).
- S. Leslie, “Broadbanding the Elevated, Inverse-Fed Ground Plane Antenna,” *The ARRL Antenna Compendium Vol 6* (Newington, CT: 1999), pp 209-211.
- R. D. Snyder, “The Snyder Antenna,” *RF Design*, Sep/Oct 1984, pp 49-51.
- R. D. Snyder, “Broadband Antennae Employing Coaxial Transmission Line Sections,” United States Patent no. 4,479,130, issued Oct 23, 1984.
- C. Whysall, “The ‘Double Bazooka’ Antenna,” *QST*, Jul 1968, pp 38-39.
- F. Witt, “A Simple Broadband Dipole for 80 Meters,” *QST*, Sept 1993, pp 27-30, 76.
- F. J. Witt, “Broadband Dipoles—Some New Insights,” *QST*, Oct 1986, pp 27-37.
- F. Witt, “Broadband Matching with the Transmission Line Resonator,” *The ARRL Antenna Compendium Vol 4* (Newington, CT: 1995), pp 30-37.
- F. Witt, “How to Design Off-Center-Fed Multiband Wire Antennas Using that Invisible Transformer in the Sky,” *The ARRL Antenna Compendium Volume 3* (Newington, CT: ARRL, 1992), p 74.
- F. Witt, “Match Bandwidth of Resonant Antenna Systems,” *QST*, Oct 1991, pp 21-25
- F. Witt, “Optimizing the 80-Meter Dipole,” *The ARRL Antenna Compendium Vol 4* (Newington, CT: 1995), pp 38-48.
- F. Witt, “Optimum Lossy Broadband Matching Networks for Resonant Antennas,” *RF Design*, Apr 1990, pp 44-51 and Jul 1990, p 10.
- F. Witt, “The Coaxial Resonator Match and the Broadband Dipole,” *QST*, Apr 1989, pp 22-27.
- F. Witt, “The Coaxial Resonator Match,” *The ARRL Antenna Compendium Volume 2* (Newington, CT: ARRL, 1989), pp 110-118.



# Chapter 10

# Log Periodic Arrays

This chapter was contributed by L. B. Cebik, W4RNL. The *Log Periodic Dipole Array (LPDA)* is one of a family of frequency-independent antennas. Alone, an LPDA forms a directional antenna with relatively constant characteristics across a wide frequency range. It may also be used with parasitic elements to achieve specific characteristic within a narrow frequency range. Common names for such hybrid arrays are the *log-cell Yagi* or the *Log-Yag*. We shall look at the essential characteristics of both types of arrays in this chapter.

The LPDA is the most popular form of log-periodic systems, which also include zig-zag, planar, trapezoidal, slot, and V forms. The appeal of the LPDA version of the log periodic antenna owes much to its structural similarity to the Yagi-Uda parasitic array. This permits the construction of directional LPDAs that can be rotated—at least within the upper HF and higher frequency ranges. Nevertheless, the LPDA has special structural as well as design considerations that distinguish it from the Yagi. A number of different construction techniques for both wire and tubular elements are illustrated later in this chapter.

The LPDA in its present form derives from the pioneering work of [D. E. Isbell](#) at the University of Illinois

in the late 1950s. Although you may design LPDAs for large frequency ranges—for example, from 3 to 30 MHz or a little over 3 octaves—the most common LPDA designs that radio amateurs use are limited to a one-octave range, usually from 14 to 30 MHz. Amateur designs for this range tend to consist of linear elements. However, experimental designs for lower frequencies have used elements shaped like inverted Vs, and some versions use vertically oriented  $\frac{1}{4} \lambda$  elements over a ground system.

**Fig 1** shows the parts of a typical LPDA. The structure consists of a number of linear elements, the longest of which is approximately  $\frac{1}{2} \lambda$  long at the lowest design frequency. The shortest element is usually about  $\frac{1}{2} \lambda$  long at a frequency well above the highest operating frequency. The antenna feeder, also informally called the *phase-line*, connects the center points of each element in the series, with a phase reversal or *cross-over* between each element. A stub consisting of a shorted length of parallel feed line is often added at the back of an LPDA.

The arrangement of elements and the method of feed yield an array with relatively constant gain and front-to-back ratio across the designed operating range. In addition, the LPDA exhibits a relatively constant feed-point impedance, simplifying matching to a transmission line.

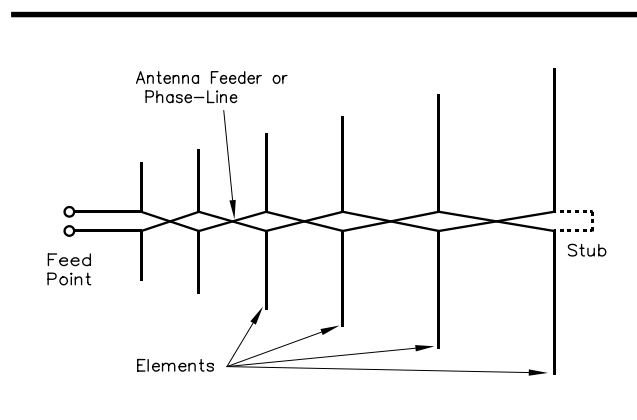
## BASIC DESIGN CONSIDERATIONS

For the amateur designer, the most fundamental facets of the LPDA revolve around three interrelated design variables:  $\alpha$  (alpha),  $\tau$  (tau), and  $\sigma$  (sigma). Any one of the three variables may be defined by reference to the other two.

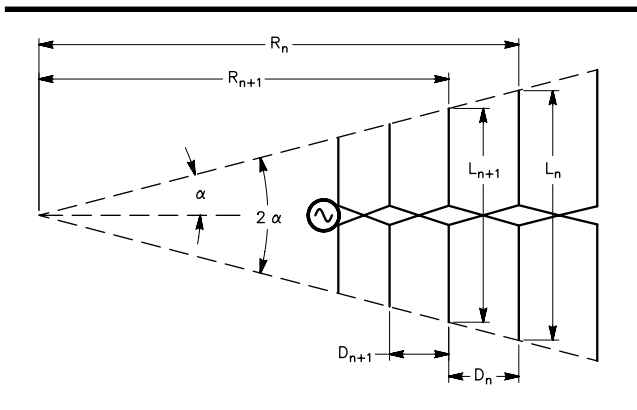
**Fig 2** shows the basic components of an LPDA. The angle  $\alpha$  defines the outline of an LPDA and permits every dimension to be treated as a radius or the consequence of a radius ( $R$ ) of a circle. The most basic structural dimensions are the element lengths ( $L$ ), the distance ( $R$ ) of each element from the apex of angle  $\alpha$ , and the distance between elements ( $D$ ). A single design constant,  $\tau$ , defines all of these relationships in the following manner:

$$\frac{R_{n+1}}{R_n} = \frac{D_{n+1}}{D_n} = \frac{L_{n+1}}{L_n} \quad (\text{Eq 1})$$

where element  $n$  and  $n+1$  are successive elements in the array working toward the apex of angle  $\alpha$ . The value of  $\tau$  is



**Fig 1**—The basic components of a log periodic dipole array (LPDA). The forward direction is to the left in this sketch. Many variations of the basic design are possible.



**Fig 2—Some fundamental relationships that define an array as an LPDA. See the text for the defining equations.**

always less than 1.0, although effective LPDA design requires values as close to 1.0 as may be feasible.

The variable  $\tau$  defines the relationship between successive element spacings but it does not itself determine the initial spacing between the longest and next longest elements upon which to apply  $\tau$  successively. The initial spacing also defines the angle  $\alpha$  for the array. Hence, we have two ways to determine the value of  $\sigma$ , the relative spacing constant:

$$\sigma = \frac{1 - \tau}{4 \tan \alpha} = \frac{D_n}{2L_n} \quad (\text{Eq 2})$$

where  $D_n$  is the distance between any two elements of the array and  $L_n$  is the length of the longer of the two elements. From the first of the two methods of determining the value of  $\sigma$ , we may also find a means of determining  $\alpha$  when we know both  $\tau$  and  $\sigma$ .

For any value of  $\tau$ , we may determine the optimal value of  $\sigma$ :

$$\sigma_{\text{opt}} = 0.243 \tau - 0.051 \quad (\text{Eq 3})$$

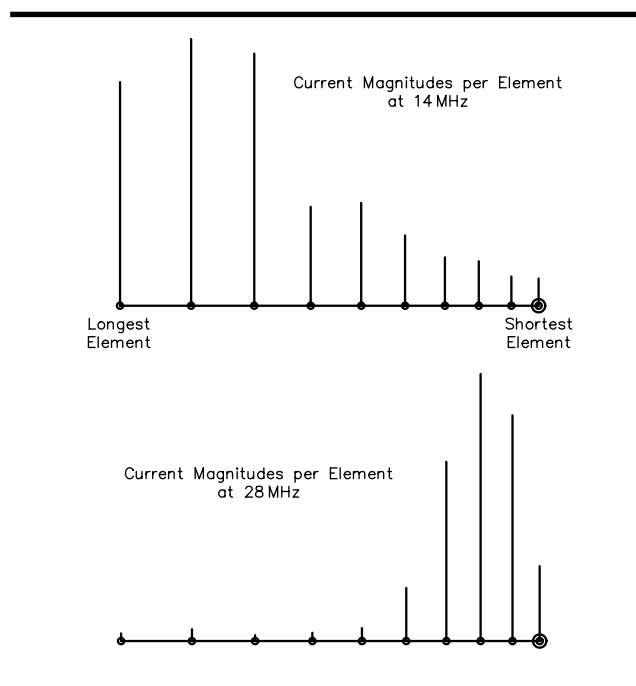
The combination of a value for  $\tau$  and its corresponding optimal value of  $\sigma$  yields the highest performance of which an LPDA is capable. For values of  $\tau$  from 0.80 through 0.98, the value of optimal  $\sigma$  varies from 0.143 to 0.187, in increments of 0.00243 for each 0.01 change in  $\tau$ . However, using the optimal value of  $\sigma$  usually yields a total array length that is beyond ham construction or tower/mast support capabilities. Consequently, amateur LPDAs usually employ compromise values of  $\tau$  and  $\sigma$  that yield lesser but acceptable performance.

For a given frequency range, increasing the value of  $\tau$  increases both the gain and the number of required elements. Increasing the value of  $\sigma$  increases both the gain and the overall boom length. A  $\tau$  of 0.96—which approaches the upper maximum recommended value for  $\tau$ —yields an optimal  $\sigma$  of about 0.18, and the resulting array grows to over 100 feet long for the 14 to 30 MHz range. The maximum

free space gain is about 11 dBi, with a front-to-back ratio that approaches 40 dB. Normal amateur practice, however, uses values of  $\tau$  from about 0.88 to 0.95 and values of  $\sigma$  from about 0.03 to 0.06.

Standard design procedures usually set the length of the rear element for a frequency about 7% lower than the lowest design frequency and use the common dipole formula ( $L_{\text{feet}} = 468/f_{\text{MHz}}$ ) to determine its length (5% lower than a free-space half wavelength, where  $L_{\text{feet}} = 493.56/f_{\text{MHz}}$ ). The upper frequency limit of the design is ordinarily set at about 1.3 times the highest design frequency. Since  $\tau$  and  $\sigma$  set the increment between successive element lengths, the number of elements becomes a function of when the shortest element reaches the dipole length for the adjusted upper frequency.

The adjusted upper frequency limit results from the behavior of LPDAs with respect to the number of active elements. See **Fig 3**, which shows an edge view of a 10-element LPDA for 20 through 10 meters. The vertical lines represent the peak relative current magnitude for each element at the specified frequency. At 14 MHz, virtually every element of the array shows a significant current magnitude. However, at 28 MHz, only the forward 5 elements carry significant current. Without the extended design range to nearly 40 MHz, the number of elements with significant current levels would be severely reduced, along with upper frequency performance.

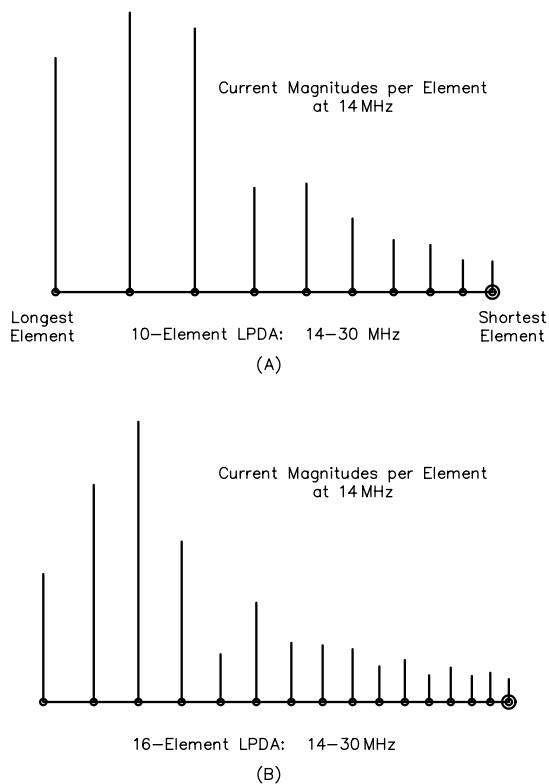


**Fig 3—The relative current magnitude on the elements of an LPDA at the lowest and highest operating frequencies for a given design. Compare the number of “active” elements, that is, those with current levels at least 1/10 of the highest level.**

The need to extend the design equations below the lowest proposed operating frequency varies with the value of  $\tau$ . In **Fig 4**, we can compare the current on the rear elements of two LPDAs, both with a  $\sigma$  value of 0.04. The upper design uses a  $\tau$  of 0.89, while the lower design uses a value of 0.93. The most significant current-bearing element moves forward with increases in  $\tau$ , reducing (but not wholly eliminating) the need for elements whose lengths are longer than a dipole for the lowest operating frequency.

### LPDA Design and Computers

Originally, LPDA design proceeded through a series of design equations intended to yield the complete specifications for an array. More recent techniques available to radio amateurs include basic LPDA design software and antenna modeling software. One good example of LPDA design software is *LPCAD28* by Roger Cox, WB0DGF. A copy of this freeware program is on the CD-ROM that accompanies this volume. The user begins by specifying the lowest and highest frequencies in the design. He then enters either his selected values for  $\tau$  and  $\sigma$  or his choices for the number of elements and the total length of the array. With this and other input data, the program provides a table of element lengths and spacings, using the adjusted upper and lower frequency limits described earlier.



**Fig 4—Patterns of current magnitude at the lowest operating frequency of two different LPDA designs: a 10-element low- $\tau$  design and a 16-element higher- $\tau$  design.**

The program also requests the diameters of the longest and shortest elements in the array, as well as the diameter of average element. From this data, the program calculates a recommended value for the phase-line connecting the elements and the approximate resistive value of the input impedance. Among the additional data that *LPCAD28* makes available is the spacing of conductors to achieve the desired characteristic impedance of the phase-line. These conductors may be round—as we would use for a wire phase-line—or square—as we might use for double-boom construction.

An additional vital output from *LPCAD28* is the conversion of the design into antenna modeling input files of several formats, including versions for *AO* and *NEC4WIN* (both *MININEC*-based programs), and a version in the standard \*.NEC format usable by many implementations of *NEC-2* and *NEC-4*, including *NECWin Plus*, *GNEC*, and *EZNEC Pro*. Every proposed LPDA design should be verified and optimized by means of antenna modeling, since basic design calculations rarely provide arrays that require no further work before construction. A one-octave LPDA represents a segment of an arc defined by  $\alpha$  that is cut off at both the upper and the lower frequency limits. Moreover, some of the design equations are based upon approximations and do not completely predict LPDA behavior. Despite these limitations, most of the sample LPDA designs shown later in this chapter are based directly upon the fundamental calculations. Therefore, the procedure will be outlined in detail before turning to hybrid log-cell Yagi concepts.

Modeling LPDA designs is most easily done on a version of *NEC*. The transmission line (TL) facility built into *NEC-2* and *NEC-4* alleviates the problem of modeling the phase-line as a set of physical wires, each section of which has a set of constraints in *MININEC* at the right-angle junctions with the elements. Although the *NEC* TL facility does not account for losses in the lines, the losses are ordinarily low enough to neglect.

*NEC* models do require some careful construction to obtain the most accurate results. Foremost among the cautions is the need for careful segmentation, since each element has a different length. The shortest element should have about 9 or 11 segments, so that it has sufficient segments at the highest modeling frequency for the design. Each element behind the shortest one should have a greater number of segments than the preceding element by the inverse of the value of  $\tau$ . However, there is a further limitation. Since the transmission line is at the center of each element, *NEC* elements should have an odd number of segments to hold the phase-line centered. Hence, each segmentation value calculated from the inverse of  $\tau$  must be rounded up to the nearest odd integer.

Initial modeling of LPDAs in *NEC-2* should be done with uniform-diameter elements, with any provision for stepped-diameter element correction turned off. Since these correction factors apply only to elements within about 15% of dipole resonance at the test frequency, models with stepped-diameter elements will correct for only a few

elements at any test frequency. The resulting combination of corrected and uncorrected elements will not yield a model with assured reliability.

Once one has achieved a satisfactory model with uniform-diameter elements, the modeling program can be used to calculate stepped-diameter substitutes. Each uniform-diameter element, when extracted from the larger array, will have a resonant frequency. Once this frequency is determined, the stepped-diameter element to be used in final construction can be resonated to the same frequency. Although *NEC-4* handles stepped diameter elements with much greater accuracy than *NEC-2*, the process just described is also applicable to *NEC-4* models for the greatest precision.

### LPDA Behavior

Although LPDA behavior is remarkably uniform over a wide frequency range compared to narrow-band designs, such as the Yagi-Uda array, it nevertheless exhibits very significant variations within the design range. **Fig 5** shows several facets of these behaviors. Fig 5 shows the free-space gain for three LPDA designs using 0.5-inch diameter aluminum elements. The designations for each model list the values of  $\tau$  (0.93, 0.89, and 0.85) and of  $\sigma$  (0.02, 0.04, and 0.06) used to design each array. The resultant array lengths are listed with each designator. The total number of elements varies from 16 for “9302” to 10 for “8904” to 7 for “8504.”

First, the gain is never uniform across the entire frequency span. The gain tapers off at both the low and high ends of the design spectrum. Moreover, the amount of gain undulates across the spectrum, with the number of peaks dependent upon the selected value of  $\tau$  and the resultant number of elements. The front-to-back ratio tends to follow the gain level. In general, it ranges from less than 10 dB

when the free-space gain is below 5 dBi to over 20 dB as the gain approaches 7 dBi. The front-to-back ratio may reach the high 30s when the free-space array gain exceeds 8.5 dBi. Well-designed arrays, especially those with high values of  $\tau$  and  $\sigma$ , tended to have well-controlled rear patterns that result in only small differences between the 180° front-to-back ratio and the averaged front-to-rear ratio.

Since array gain is a mutual function of both  $\tau$  and  $\sigma$ , average gain becomes a function of array length for any given frequency range. Although the gain curves in Fig 5 interweave, there is little to choose among them in terms of average gain for the 14 to 18-foot range of array lengths. Well-designed 20- to 10-meter arrays in the 30-foot array length region are capable of about 7 dBi free-space gain, while 40-foot arrays for the same frequency range can achieve about 8 dBi free-space gain.

Exceeding an average gain of 8.5 dBi requires at least a 50-foot array length for this frequency range. Long arrays with high values of  $\tau$  and  $\sigma$  also tend to show smaller excursions of gain and of front-to-back ratio in the overall curves. In addition, high- $\tau$  designs tend to show higher gain at the low frequency end of the design spectrum.

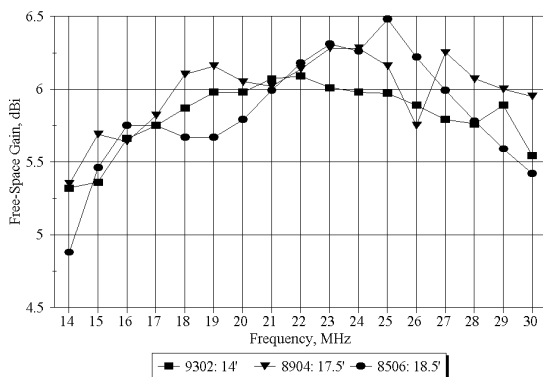
The frequency sweeps shown in Fig 5 are widely spaced at 1 MHz intervals. The evaluation of a specific design for the 14 to 30-MHz range should decrease the interval between check points to no greater than 0.25 MHz in order to detect frequencies at which the array may show a *performance weakness*. Weaknesses are frequency regions in the overall design spectrum at which the array shows unexpectedly lower values of gain and front-to-back ratio. In Fig 5 note the unexpected decrease in gain of model “8904” at 26 MHz. The other designs also have weak points, but they fall between the frequencies sampled.

In large arrays, these regions may be quite small and may occur in more than one frequency region. The weakness results from the harmonic operation of longer elements to the rear of those expected to have high current levels. Consider a 7-element LPDA about 12.25-foot long for 14 to 30 MHz using 0.5-inch aluminum elements. At 28 MHz, the rear elements operate in a harmonic mode, as shown by the high relative current magnitude curves in Fig 6. The result is a radical decrease in gain, as shown in the “No Stub” curve of Fig 7. The front-to-back ratio also drops as a result of strong radiation from the long elements to the rear of the array.

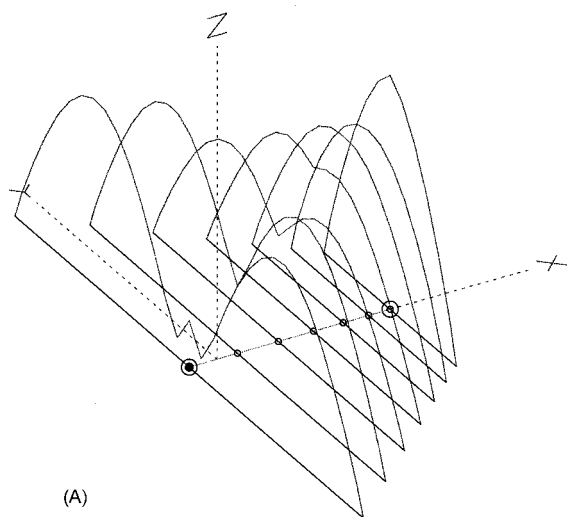
Early designs of LPDAs called for terminating transmission-line stubs as standard practice to help eliminate such weak spots in frequency coverage. In contemporary designs, their use tends to be more specific for eliminating or moving frequencies that show gain and front-to-back weakness. (Stubs have the added function of keeping both sides of each element at the same level of static charge or discharge.) The model dubbed “8504” was fitted (by trial and error) with an 18-inch shorted stub of 600- $\Omega$  transmission line. As Fig 6B shows, the harmonic operation

#### Short-Boom LPDAs: 14' to 18.5'

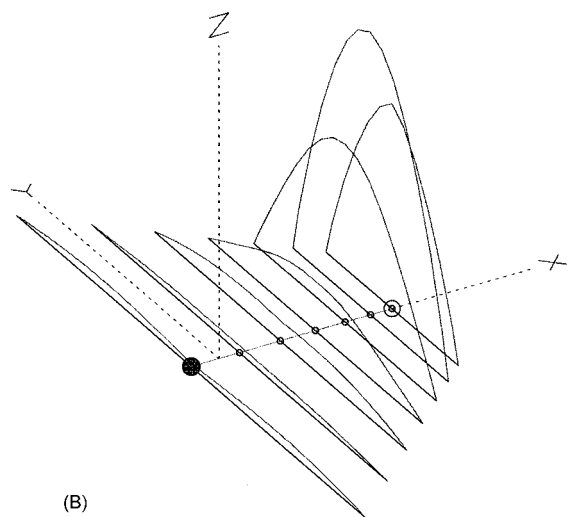
Free-Space Gain: 14 to 30 MHz



**Fig 5—The modeled free-space gain of 3 relatively small LPDAs of different design. Note the relationship of the values of  $\tau$  and of  $\sigma$  for these arrays with quite similar performance across the 14-30 MHz span.**



(A)



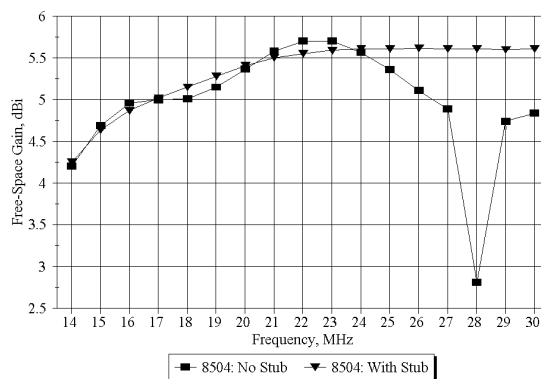
(B)

**Fig 6—The relative current magnitude on the elements of model “8504” at 28 MHz without and with a stub. Note the harmonic operation of the rear elements before a stub is added to suppress such operation.**

of the rear elements is attenuated. The “stub” curve of Fig 7 shows the smoothing of the gain curve for the array throughout the upper half of its design spectrum. In some arrays showing multiple weaknesses, a single stub may not eliminate all of them. However, it may move the weaknesses to unused frequency regions. Where full-spectrum operation of an LPDA is necessary, additional stubs located at specific elements may be needed.

Most LPDA designs benefit (with respect to gain and front-to-back ratio) from the use of larger-diameter elements. Elements with an average diameter of at least 0.5-inch are desirable in the 14 to 30 MHz range. However, standard designs usually presume a constant element length-to-diameter ratio. In the case of *LPCAD28*, this ratio is about

**Sample LPDAs: Free-Space Gain**  
With and Without Corrective Stub

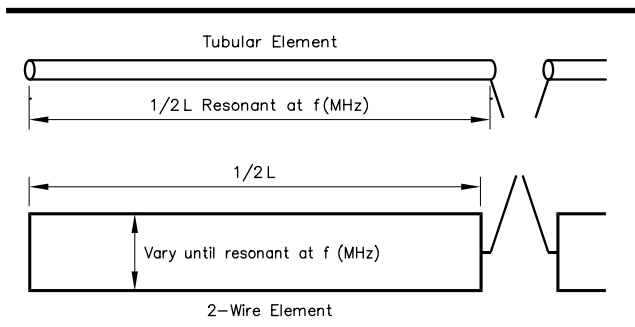


**Fig 7—A graph of the gain of model “8504” showing the frequency region in which a “weakness” occurs and its absence once a suitable stub is added to the array.**

125:1, which assumes an even larger diameter. To achieve a relatively constant length-to-diameter ratio in the computer models, you can set the diameter of the shortest element in a given array design and then increase the element diameter by the inverse of  $\tau$  for each succeeding longer element. This procedure is often likely to result in unreasonably large element diameters for the longest elements, relative to standard amateur construction practices.

Since most amateur designs using aluminum tubing for elements employ stepped-diameter (tapered) elements, roughly uniform element diameters will result unless the LPDA mechanical design tries to lighten the elements at the forward end of the array. This practice may not be advisable, however. Larger elements at the high end of the design spectrum often counteract (at least partially) the natural decrease in high-frequency gain and show improved performance compared to smaller diameter elements.

An alternative construction method for LPDAs uses wire throughout. At every frequency, single-wire elements reduce gain relative to larger-diameter tubular elements. An alternative to tubular elements appears in Fig 8. For each element of a tubular design, there is a roughly equivalent 2-wire element that may be substituted. The spacing between the wire is determined by taking one of the modeled tubular elements and finding its resonant frequency. A two-wire element of the same length is then constructed with shorts at the far ends and at the junctions with the phase-line. The separation of the two wires is adjusted until the wire element is resonant at the same frequency as the original tubular element. The required separation will vary with the wire chosen for the element. Models used to develop these substitutes must pay close attention to segmentation rules for NEC due to the short length of segments in the end and center shorts, and to the need to keep segment junctions as exactly parallel as possible with close-spaced wires.



**Fig 8—A substitute for a large-diameter tubular element composed of two wires shorted at both the outer ends and at the center junction with the phase-line.**

### Feeding and Constructing the LPDA

Original design procedures for LPDAs used a single, ordinarily fairly high, characteristic impedance for the phase-line (antenna feeder). Over time, designers realized that other values of impedance for the phase line offered both mechanical and performance advantages for LPDA performance. Consequently, for the contemporary designer, phase-line choice and construction techniques are almost inseparable considerations.

High-impedance phase lines (roughly 200 Ω and higher) are amenable to wire construction similar to that used with ordinary parallel-wire transmission lines. They require careful placement relative to a metal boom used to support individual elements (which themselves must be insulated from the support boom). Connections also require care. If the phase-line is given a half-twist between each element,

the construction of the line must ensure constant spacing and relative isolation from metal supports to maintain a constant impedance and to prevent shorts.

Along with the standard parallel-wire line, shown in **Fig 9A**, there are a number of possible LPDA structures using booms. The booms serve both to support the elements and to create relatively low-impedance (under 200 Ω) phase-lines. Fig 9B shows the basics of a twin circular tubing boom with the elements cross-supported by insulated rods. Fig 9C shows the use of square tubing with the elements attached directly to each tube by through-bolts. Fig 9D illustrates the use of L-stock, which may be practical at VHF frequencies. Each of these sketches is incomplete, however, since it omits the necessary stress analyses that determine the mechanical feasibility of a structure for a given LPDA project.

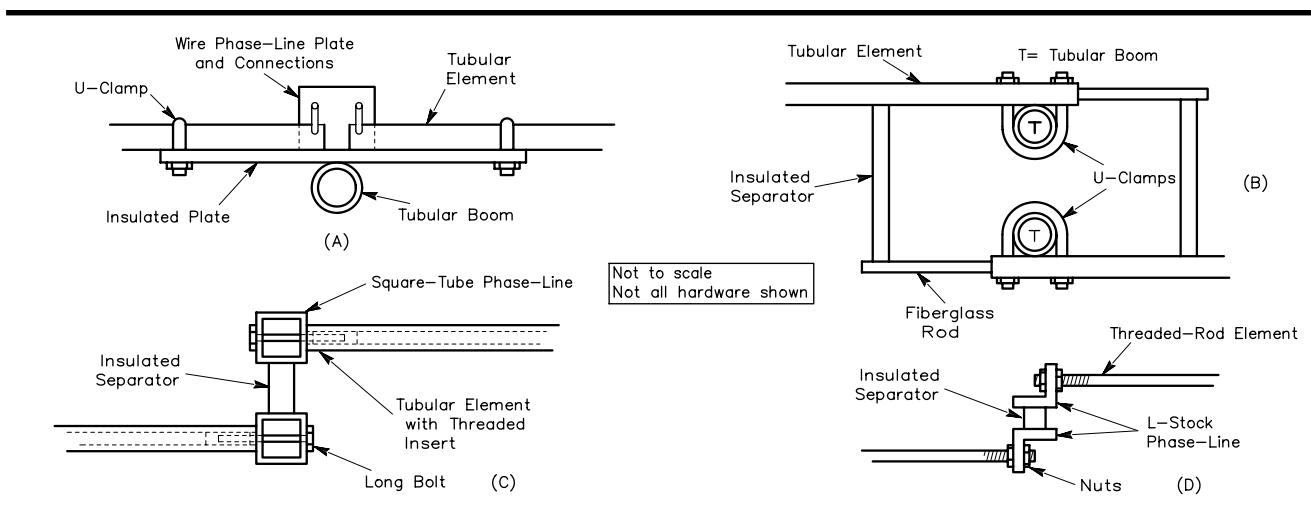
The use of square boom material requires some adjustment when calculating the characteristic impedance of the phase-line. For conductors with a circular cross-section,

$$Z_0 = 120 \cosh^{-1} \frac{D}{d} \quad (\text{Eq 4})$$

where  $D$  is the center-to-center spacing of the conductors and  $d$  is the outside diameter of each conductor, both expressed in the same units of measurement. Since we are dealing with closely spaced conductors, relative to their diameters, the use of this version of the equation for calculating the characteristic impedance ( $Z_0$ ) is recommended. For a square conductor,

$$d \approx 1.18 w \quad (\text{Eq 5})$$

where  $d$  is the approximate equivalent diameter of the square tubing and  $w$  is the width of the tubing across one side. Thus, for a given spacing, a square tube permits you to achieve a



**Fig 9—Four (of many) possible construction techniques, shown from the array end. In A, an insulated plate supports and separates the wires of the phase-line, suitable with wire or tubular elements. A dual circular boom phase-line also supports the elements, which are cross-supported for boom stability. Square tubing is used in C, with the elements joined to the boom/phase-line with through-bolts and an insert in each half element. The L-stock shown in D is useful for lighter VHF and UHF arrays.**

lower characteristic impedance than round conductors. However, square tubing requires special attention to matters of strength, relative to comparable round tubing.

Electrically, the characteristic impedance of the LPDA phase-line tends to influence other performance parameters of the array. Decreasing the phase-line  $Z_0$  also decreases the feed-point impedance of the array. For small designs with few elements, the decrease is not fully matched by a decrease in the excursions of reactance. Consequently, using a low impedance phase-line may make it more difficult to achieve a 2:1 or less SWR for the entire frequency range. However, higher-impedance phase-lines may result in a feed-point impedance that requires the use of an impedance-matching balun.

Decreasing the phase-line  $Z_0$  also tends to increase LPDA gain and front-to-back ratio. There is a price to be paid for this performance improvement—weaknesses at specific frequency regions become much more pronounced with reductions in the phase-line  $Z_0$ . For a specific array you must weigh carefully the gains and losses, while employing one or more transmission line stubs to get around performance weaknesses at specific frequencies.

Depending upon the specific values of  $\tau$  and  $\sigma$  selected for a design, you can sometimes select a phase-line  $Z_0$  that provides either a 50- $\Omega$  or a 75- $\Omega$  feed-point impedance, holding the SWR under 2:1 for the entire design range of the LPDA. The higher the values of  $\tau$  and  $\sigma$  for the design, the lower the reactance and resistance excursions around a central value. Designs using optimal values of  $\sigma$  with high values of  $\tau$  show a very slight capacitive reactance throughout the frequency range. Lower design values obscure this phenomenon due to the wide range of values taken by both resistance and reactance as the frequency is changed.

At the upper end of the frequency range, the source resistance value decreases more rapidly than elsewhere in the design spectrum. In larger arrays, this can be overcome by using a variable  $Z_0$  phase-line for approximately the first 20% of the array length. This technique is, however, difficult to implement with anything other than wire phase-lines. Begin with a line impedance about half of the final value and increase the wire spacing evenly until it reaches its final and fixed spacing. This technique can sometimes produce smoother impedance performance across the entire frequency span and improved high-frequency SWR performance.

Designing an LPDA requires as much attention to designing the phase-line as to element design. It is always useful to run models of the proposed design through several iterations of possible phase-line  $Z_0$  values before freezing the structure for construction.

### Special Design Corrections

The curve for the sample 8504 LPDA in Fig 7 revealed several deficiencies in standard LPDA designs. The weakness in the overall curve was corrected by the use of a stub to eliminate or move the frequency at which rearward elements

operated in a harmonic mode. In the course of describing the characteristics of the array, we have noted several other means to improve performance. Fattening elements (either uniformly or by increasing their diameter in step with  $\tau$ ) and reducing the characteristic impedance of the phase-line are capable of small improvements in performance. However, they cannot wholly correct the tendency of the array gain and front-to-back ratio to fall off at the upper and lower limits of the LPDA frequency range.

One technique sometimes used to improve performances near the frequency limits is to design the LPDA for upper and lower frequency limits much higher and lower than the frequencies of use. This technique unnecessarily increases the overall size of the array and does not eliminate the downward performance curves. Increasing the values of  $\tau$  and  $\sigma$  will usually improve performance at no greater cost in size than extending the frequency range. Increasing the value of  $\tau$  is especially effective in improving the low frequency performance of an LPDA.

Working within the overall size limits of a standard design, one may employ a technique of *circularizing* the value of  $\tau$  for the rear-most and forward-most elements. See Fig 10, which is not to-scale relative to overall array length and width. Locate (using an antenna-modeling program) the element with the highest current at the lowest operating frequency, and the element with the highest current at the highest operating frequency. The adjustments to element lengths may begin with these elements or—at most—one element further toward the array center. For the first element (counting from the center) to be modified, reduce the value of  $\tau$  by about 0.5%. For a rearward element, use the inverse of the adjusted value of  $\tau$  to calculate the new length of the element relative to the unchanged element just forward of

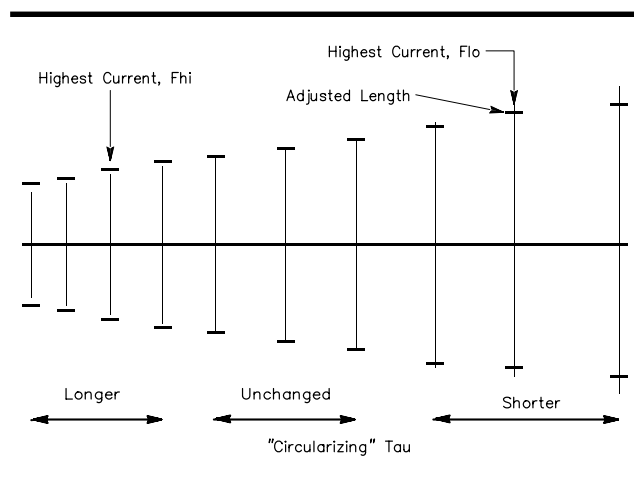


Fig 10—A before and after sketch of an LPDA, showing the original lengths of the elements and their adjustments from diminishing the value of  $\tau$  at both ends of the array. See the text for the amount of change applicable to each element.

the change. For a forward element, use the new value of  $\tau$  to calculate the new length of the element relative to the unchanged element immediately to the rear of it.

For succeeding elements outward, calculate new values of  $\tau$  from the adjusted values, increasing the increment of decrease with each step. Second adjusted elements may use values of  $\tau$  about 0.75% to 1.0% lower than the values just calculated. Third adjusted elements may use an increment of 1.0% to 1.5% relative to the preceding value.

Not all designs require extensive treatment. As the values of  $\tau$  and  $\sigma$  increase, fewer elements may require adjustment to obtain the highest possible gain at the frequency limits, and these will always be the most outward elements in the array. A second caution is to check the feed-point impedance of the array after each change to ensure that it remains within design limits.

**Fig 11** shows the free-space gain curves from 14 to 30 MHz for a 10-element LPDA with an initial  $\tau$  of 0.89 and a  $\sigma$  of 0.04. The design uses a 200- $\Omega$  phase-line, 0.5-inch aluminum elements, and a 3-inch 600- $\Omega$  stub. The lowest curve shows the modeled performance across the design frequency range with only the stub. Performance at the frequency limits is visibly lower than within the peak performance region. The middle curve shows the effects of circularizing  $\tau$ . Average performance levels have improved noticeably at both ends of the spectrum.

In lieu of, or in addition to, the adjustment of element lengths, you may also add a parasitic director to an LPDA, as shown in **Fig 12**. The director is cut roughly for the highest operating frequency. It may be spaced between 0.1  $\lambda$  and 0.15  $\lambda$  from the forward-most element of the LPDA. The exact length and spacing should be determined exper-

imentally (or from models) with two factors in mind. First, the element should not adversely effect the feed-point impedance at the highest operating frequencies. Close spacing of the director has the greatest effect on this impedance. Second, the exact spacing and element length should be set to have the most desired effect on the overall performance curve of the array. The mechanical impact of adding a director is to increase overall array length by the spacing selected for the element.

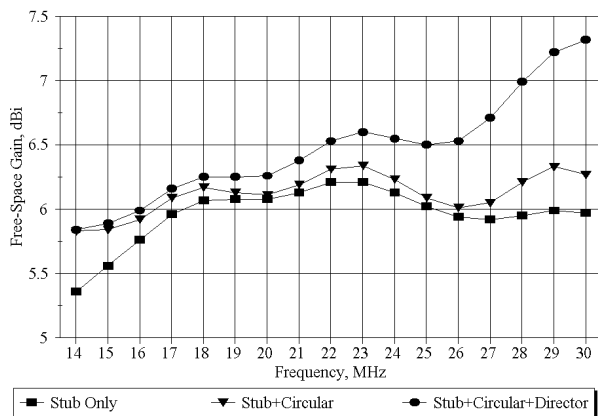
The upper curve in Fig 11 shows the effect of adding a director to the circularized array already equipped with a stub. The effect of the director is cumulative, increasing the upper range gain still further. Note that the added parasitic director is not just effective at the highest frequencies within the LPDA design range. It has a perceptible effect almost all the way across the frequency span of the array, although the effect is smallest at the low-frequency end of the range.

The addition of a director can be used to enhance upper frequency performance of an LPDA, as in the illustration, or simply to equalize upper frequency performance with mid-range performance. High- $\tau$  designs, with good low-frequency performance, may need only a director to compensate for high-frequency gain decrease. One potential challenge to adding a director to an LPDA is sustaining a high front-to-back ratio at the upper frequency range.

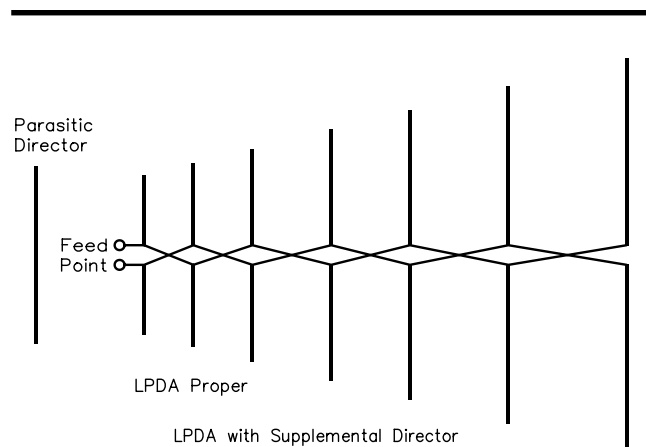
Throughout the discussion of LPDAs, the performance curves of sample designs have been treated at all frequencies alike, seeking maximum performance across the entire design frequency span. Special compensations are also possible for ham-band-only LPDA designs. They include the insertion of parasitic elements within the array as well as outside the initial design boundaries. In addition, stubs may be employed not so much to eliminate weaknesses, but only to move them to frequencies outside the range of amateur interests.

### Special Corrections: 14 to 30 MHz LPDA

Stub, Circularization, Extra Director



**Fig 11**—The modeled free space gain from 14 to 30 MHz of an LPDA with  $\tau$  of 0.89 and  $\sigma$  of 0.04. Squares: just a stub to eliminate a weakness; Triangles: with a stub and circularized elements, and Circles: with a stub, circularized elements and a parasitic director.



**Fig 12**—A generalized sketch of an LPDA with the addition of a parasitic director to improve performance at the higher frequencies within the design range.



## A DESIGN PROCEDURE FOR AN LPDA

The following presents a systematic step-by-step design procedure for an LPDA with any desired bandwidth. The procedure requires some mathematical calculations, but a common calculator with square-root, logarithmic, and trigonometric functions is completely adequate. The notation used in this section may vary slightly from that used earlier in this chapter.

1) Decide on an operating bandwidth  $B$  between  $f_1$ , lowest frequency and  $f_n$ , highest frequency:

$$B = \frac{f_n}{f_1} \quad (\text{Eq 6})$$

2) Choose  $\tau$  and  $\sigma$  to give the desired estimated average gain.

$$0.8 \leq \tau \leq 0.98 \text{ and } 0.03 \leq \sigma \leq \sigma_{\text{opt}} \quad (\text{Eq 7})$$

where  $\sigma_{\text{opt}}$  is calculated as noted earlier in this chapter.

3) Determine the value for the cotangent of the apex half-angle  $\alpha$  from

$$\cot \alpha = \frac{4\sigma}{1-\tau} \quad (\text{Eq 8})$$

Although  $\alpha$  is not directly used in the calculations,  $\cot \alpha$  is used extensively.

4) Determine the bandwidth of the active region  $B_{\text{ar}}$  from

$$B_{\text{ar}} = 1.1 + 7.7(1-\tau)^2 \cot \alpha \quad (\text{Eq 9})$$

5) Determine the structure (array) bandwidth  $B_s$  from

$$B_s = B \times B_{\text{ar}} \quad (\text{Eq 10})$$

6) Determine the boom length  $L$ , number of elements  $N$ , and longest element length  $\ell_1$ .

$$L_n = \left(1 - \frac{1}{B_s}\right) \cot \alpha \times \frac{\lambda_{\text{max}}}{4} \quad (\text{Eq 11})$$

$$\lambda_{\text{max}} = \frac{984}{f_1} \quad (\text{Eq 12})$$

$$N = 1 + \frac{\log B_s}{\log \frac{1}{\tau}} = 1 + \frac{\ln B_s}{\ln \frac{1}{\tau}} \quad (\text{Eq 13})$$

$$\ell_{1\text{ft}} = \frac{492}{f_1} \quad (\text{Eq 14})$$

Usually the calculated value for  $N$  will not be an integral number of elements. If the fractional value is more than about 0.3, increase the value of  $N$  to the next higher integer. Increasing the value of  $N$  will also increase the actual value of  $L$  over that obtained from the sequence of calculations just performed.

Examine  $L$ ,  $N$  and  $\ell_1$  to determine whether or not the array size is acceptable for your needs. If the array is too large, increase  $f_1$  or decrease  $\sigma$  or  $\tau$  and repeat steps 2 through 6. Increasing  $f_1$  will decrease all dimensions. Decreasing  $\sigma$  will decrease the boom length. Decreasing  $\tau$  will decrease both the boom length and the number of elements.

7) Determine the terminating stub  $Z_t$ . (Note: For many HF arrays, you may omit the stub, short out the longest element with a 6-inch jumper, or design a stub to overcome a specific performance weakness.) For VHF and UHF arrays calculate the stub length from

$$Z_t = \frac{\lambda_{\text{max}}}{8} \quad (\text{Eq 15})$$

8) Solve for the remaining element lengths from

$$\ell_n = \tau \ell_{n-1} \quad (\text{Eq 16})$$

9) Determine the element spacing  $d_{1-2}$  from

$$d_{1-2} = \frac{(\ell_1 - \ell_2) \cot \alpha}{2} \quad (\text{Eq 17})$$

where  $\ell_1$  and  $\ell_2$  are the lengths of the rearmost elements, and  $d_{1-2}$  is the distance between the elements with the lengths  $\ell_1$  and  $\ell_2$ . Determine the remaining element-to-element spacings from

$$d_{(n-1)-n} = \tau d_{(n-2)-(n-1)} \quad (\text{Eq 18})$$

10) Choose  $R_0$ , the desired feed-point resistance, to give the lowest SWR for the intended balun ratio and feed-line impedance.  $R_0$ , the mean radiation resistance level of the LPDA input impedance, is approximated by:

$$R_0 = \frac{Z_0}{\sqrt{1 + \frac{Z_0}{4\sigma'Z_{\text{AV}}}}} \quad (\text{Eq 19})$$

where the component terms are defined and/or calculated in the following way.

From the following equations, determine the necessary antenna feeder (phase-line) impedance,  $Z_0$ :

$$Z_0 = \frac{R_0^2}{8\sigma'Z_{\text{AV}}} + R_0 \sqrt{\left(\frac{R_0}{8\sigma'Z_{\text{AV}}}\right)^2 + 1} \quad (\text{Eq 20})$$

$\sigma'$  is the mean spacing factor and is given by

$$\sigma' = \frac{\sigma}{\sqrt{\tau}} \quad (\text{Eq 21})$$

$Z_{\text{AV}}$  is the average characteristic impedance of a dipole and is given by

$$Z_{\text{AV}} = 120 \left[ \ln \left( \frac{\ell_n}{\text{diam}_n} \right) - 2.25 \right] \quad (\text{Eq 22})$$

The ratio,  $l_n/\text{diam}_n$  is the length-to-diameter ratio of the element  $n$ .

11) Once  $Z_0$  has been determined, select a combination of conductor size and spacing to achieve that impedance, using the appropriate equation for the shape of the conductors. If an impractical spacing results for the antenna feeder, select a different conductor diameter and repeat step 11. In severe cases it may be necessary to select a different  $R_0$  and repeat steps 10 and 11. Once a satisfactory feeder arrangement is found, the LPDA design is complete.

A number of the LPDA design examples at the end of this chapter make use of this calculation method. However, the resultant design should be subjected to extensive modeling tests to determine whether there are performance deficiencies or weaknesses that require modification of the design before actual construction.

### Log-Cell Yagis

Fig 12 showed an LPDA with an added parasitic director. Technically, this converts the original design into a hybrid Log-Yag. However, the term *Log-Yag* (or more generally the *log-cell Yagi*) is normally reserved for monoband designs that employ two or more elements in a single-band LPDA arrangement, together with (usually) a reflector and one or more directors. The aim is to produce a monoband directive array with superior directional qualities over a wider bandwidth than can be obtained from many Yagi-Uda designs. Log-cells have also been successfully used as wide-band driver sections for multi-band Yagi beams.

Fig 13 illustrates the general outline of a typical log-cell Yagi. The driver section consists of a log periodic array designed for the confines of a single amateur band or other narrow range of frequencies. The parasitic reflector is usually spaced about  $0.085 \lambda$  behind the rear element of the log cell, while the parasitic director is normally placed between  $0.13$  and  $0.15 \lambda$  ahead of the log cell.

Early log-cell Yagis tended to be casually designed. Most of these designs have inferior performance compared

with present-day computer-optimized Yagis of the same boom length. Some were designed by adding one or more parasitic directors to simple phased pairs of elements. Although good performance is possible, the operating bandwidth of these designs is small, suitable only for the so-called WARC bands. However, when the log-cell is designed as a narrowly spaced monoband log periodic array, the operating bandwidth increases dramatically. Operating bandwidth here refers not just to the SWR bandwidth, but also to the gain and front-to-back bandwidth.

The widest operating bandwidths require log cells of 3 to 4 elements for HF bands like 20 meters, and 4 to 5 elements for bands as wide as 10 meters. (The bandwidth of the 20-meter band is approximately 2.4% of the center frequency, while the bandwidth of the 10-meter band approaches 9.4% of the center frequency.) A practical limit to  $\sigma$  for log cells used within parasitic arrays is about 0.05. Slightly higher gain may be obtained from higher values of  $\sigma$ , but at the cost of a much longer log cell. The limiting figure for  $\sigma$  results in a practical value for  $\tau$  between 0.94 and 0.95 to achieve a cell with the desired bandwidth characteristics.

An array designed according to these principles has an overall length that varies with the size of the log cell. A typical array with a 4-element log-cell and single parasitic elements fore and aft is a bit over  $0.35 \lambda$  long, while a 5-element log-cell Yagi will be between  $0.4$  and  $0.45 \lambda$  long. Spacing the reflector more widely (for example, up to  $0.25 \lambda$ ) has little effect on either gain or front-to-back ratio. Wider spacing of the director will also have only a small effect on gain, since the arrangement is already close to the boom-length limit recommended for director-driver-reflector arrays. Further lengthening of the boom should be accompanied by the addition of one or more directors to the array, if additional gain is desired from the design.

Compared to a modern-day Yagi of the same boom length, the log-cell Yagi is considerably heavier and exhibits a higher wind load due to the requirements of the log-cell driver. Yagis with 3- and 4-elements within the boom lengths just given are capable of peak free-space gain values of 8.2 to 8.5 dBi, while sustaining a high front-to-back ratio. Peak front-to-back ratios are typically in the vicinity of 25 dB. However, Yagi gain tends to decrease below the design frequency (and increase above it), while the front-to-back ratio tends to taper off as one moves away from the design frequency. For the largest log-cell sizes, log-cell Yagis of the indicated boom lengths are capable of sustaining at least 8.2 dBi free-space gain over the entire band, with front-to-back ratios of over 30 dB across the operating bandwidth.

The feed-point impedance of a log-cell Yagi is a function of both the cell design and the influence of the parasitic elements. However, for most cell designs and common phase-line designs, you can achieve a very low variation of resistance and reactance across a desired band. In many cases, the feed impedance will form a direct match for the standard 50- $\Omega$  coaxial cable used by most amateur installations. (In contrast, the high-gain, high-front-to-back

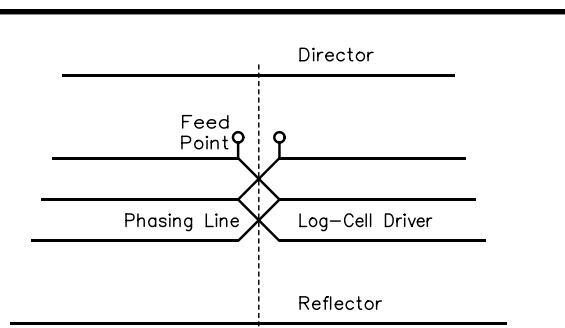
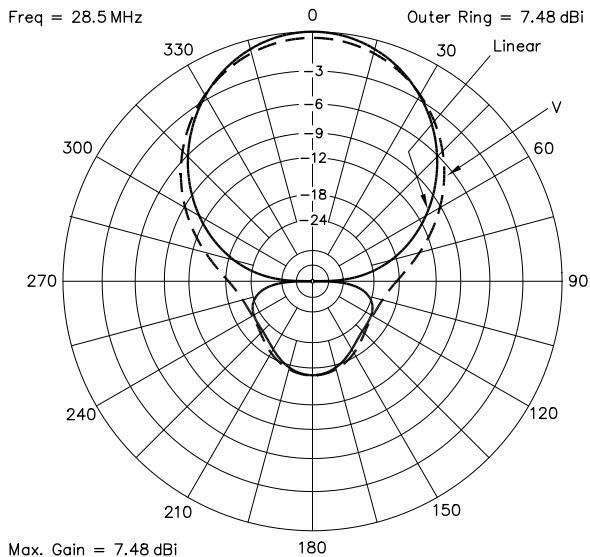


Fig 13—A sketch of a typical monoband log-cell Yagi. The reflector is, in principle, optional. The log-cell may have from 2 to 5 (or more elements). There may be one or more directors.



**Fig 14—Overlaid free-space azimuth patterns for virtually identical 5-element log-cell Yagis (with 3-element log-cells), one having the elements V'd forward at 40° from linear (dashed), the other with linear elements (solid).**

Yagis used for comparison here have feed-point impedances ranging from 20 to 25 Ω.)

A common design technique used in some LPDA and log-cell Yagi designs is to bend the elements forward to form a series of Vs. A forward angle on each side of the array centerline of about 40° relative to a linear element has been popular. In some instances, the mechanical design of the array may dictate this element formation. However, this arrangement has no special benefits and possibly may degrade performance.

**Fig 14** shows the free-space azimuth patterns of a single 5-element log-cell Yagi in two versions: with the elements linear and with the elements bent forward 40°. The V-array loses about 1/2 dB gain, but more significantly, it loses considerable signal rejection from the sides. Similar comparisons can be obtained from pure LPDA designs and from Yagi-Uda designs when using elements in the vicinity of 1/2 λ. Unless mechanical considerations call for arranging the elements in a V, the technique is not recommended.

Ultimately, the decision to build and use a log-cell Yagi involves balancing the additional weight and wind-load requirements of this design against the improvements in operating bandwidth for all of the major operating parameters, especially with respect to the front-to-back ratio and the feed-point impedance.

## Wire Log-Periodic Dipole Arrays for 3.5 or 7 MHz

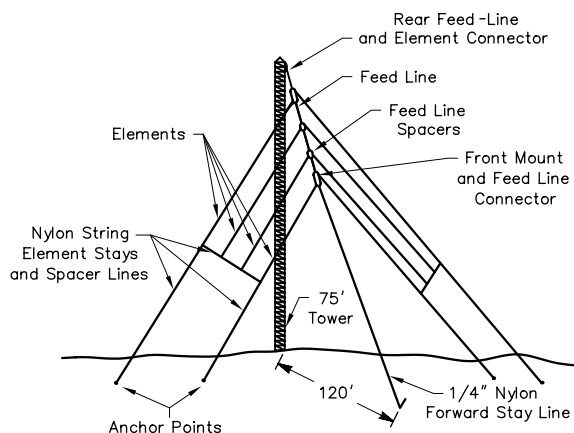
These wire log-periodic dipole arrays for the lower HF bands are simple in design and easy to build. They are designed to have reasonable gain, be inexpensive and lightweight, and may be assembled with stock items found in large hardware stores. They are also strong—they can withstand a hurricane! These antennas were first described by [John J. Uhl, KV5E](#), in *QST* for August, 1986. **Fig 15** shows one method of installation. You can use the information here as a guide and point of reference for building similar LPDAs.

If space is available, the antennas can be rotated or repositioned in azimuth after they are completed. A 75-foot tower and a clear turning radius of 120 feet around the base of the tower are needed. The task is simplified if you use only three anchor points, instead of the five shown in Fig 15. Omit the two anchor points on the forward element, and extend the two nylon strings used for element stays all the way to the forward stay line.

### DESIGN OF THE LOG-PERIODIC DIPOLE ARRAYS

Design constants for the two arrays are listed in [Tables 1](#) and [2](#). The preceding sections of this chapter contain the

design procedure for arriving at the dimensions and other parameters of these arrays. The primary differences between these designs and one-octave upper HF arrays are the



**Fig 15—Typical lower-HF wire 4-element log periodic dipole array erected on a tower.**

**Table 1**  
**Design Parameters for the 3.5-MHz Single-Band LPDA**

$f_1 = 3.3$ MHz	Element lengths:
$f_n = 4.1$ MHz	$\ell_1 = 149.091$ feet
$B = 1.2424$	$\ell_2 = 125.982$ feet
$\tau = 0.845$	$\ell_3 = 106.455$ feet
$\sigma = 0.06$	$\ell_4 = 89.954$ feet
Gain = 5.9 dBi = 3.8 dBd	Element spacings:
$\cot \alpha = 1.5484$	$d_{12} = 17.891$ feet
$B_{ar} = 1.3864$	$d_{23} = 15.118$ feet
$B_s = 1.7225$	$d_{34} = 12.775$ feet
$L = 48.42$ feet	Element diameters
$N = 4.23$ elements (decrease to 4)	All = 0.0641 inches
$Z_t = 6$ -inch short jumper	$\ell/\text{diameter}$ ratios:
$R_0 = 208 \Omega$	$\ell/\text{diam}_4 = 16840$
$Z_{AV} = 897.8 \Omega$	$\ell/\text{diam}_3 = 19929$
$\sigma' = 0.06527$	$\ell/\text{diam}_2 = 23585$
$Z_0 = 319.8 \Omega$	$\ell/\text{diam}_1 = 27911$
Antenna feeder:	
#12 wire spaced 0.58 inches	
Balun: 4:1	
Feed line: 52- $\Omega$ coax	

**Table 2**  
**Design Parameters for the 7-MHz Single-Band LPDA**

$f_1 = 6.9$ MHz	Element lengths:
$f_n = 7.5$ MHz	$\ell_1 = 71.304$ feet
$B = 1.0870$	$\ell_2 = 60.252$ feet
$\tau = 0.845$	$\ell_3 = 50.913$ feet
$\sigma = 0.06$	$\ell_4 = 43.022$ feet
Gain = 5.9 dBi = 3.8 dBd	Element spacings:
$\cot \alpha = 1.5484$	$d_{12} = 8.557$ feet
$B_{ar} = 1.3864$	$d_{23} = 7.230$ feet
$B_s = 1.5070$	$d_{34} = 6.110$ feet
$L = 18.57$ feet	Element diameters:
$N = 3.44$ elements (increase to 4)	All = 0.0641 inches
$Z_t = 6$ -inch short jumper	$\ell/\text{diameter}$ ratios:
$R_0 = 208 \Omega$	$\ell_4/\text{diam}_4 = 8054$
$Z_{AV} = 809.3 \Omega$	$\ell_3/\text{diam}_3 = 9531$
$\sigma' = 0.06527$	$\ell_2/\text{diam}_2 = 11280$
$Z_0 = 334.2 \Omega$	$\ell_1/\text{diam}_1 = 13349$
Antenna feeder:	
#12 wire spaced 0.66 inches	
Balun: 4:1	
Feed line: 52- $\Omega$ coax	

narrower frequency ranges and the use of wire, rather than tubing, for the elements. As design examples for the LPDA, you may wish to work through the step-by-step procedure and check your results against the values in Tables 1 and 2. You may also wish to compare these results with the output of an LPDA design software package such as *LPCAD28*.

From the design procedure, the feeder wire spacings for the two arrays are slightly different, 0.58 inch for the 3.5-MHz array and 0.66 inch for the 7-MHz version. As a compromise toward the use of common spacers for both bands, a spacing of  $5/8$  inch is quite satisfactory. Surprisingly, the feeder spacing is not at all critical here from a matching standpoint, as may be verified from  $Z_0 = 276 \log(2S/\text{diam})$  and from Eq 4. Increasing the spacing to as much as  $3/4$  inch results in an  $R_0$  SWR of less than 1.1:1 on both bands.

### Constructing the Arrays

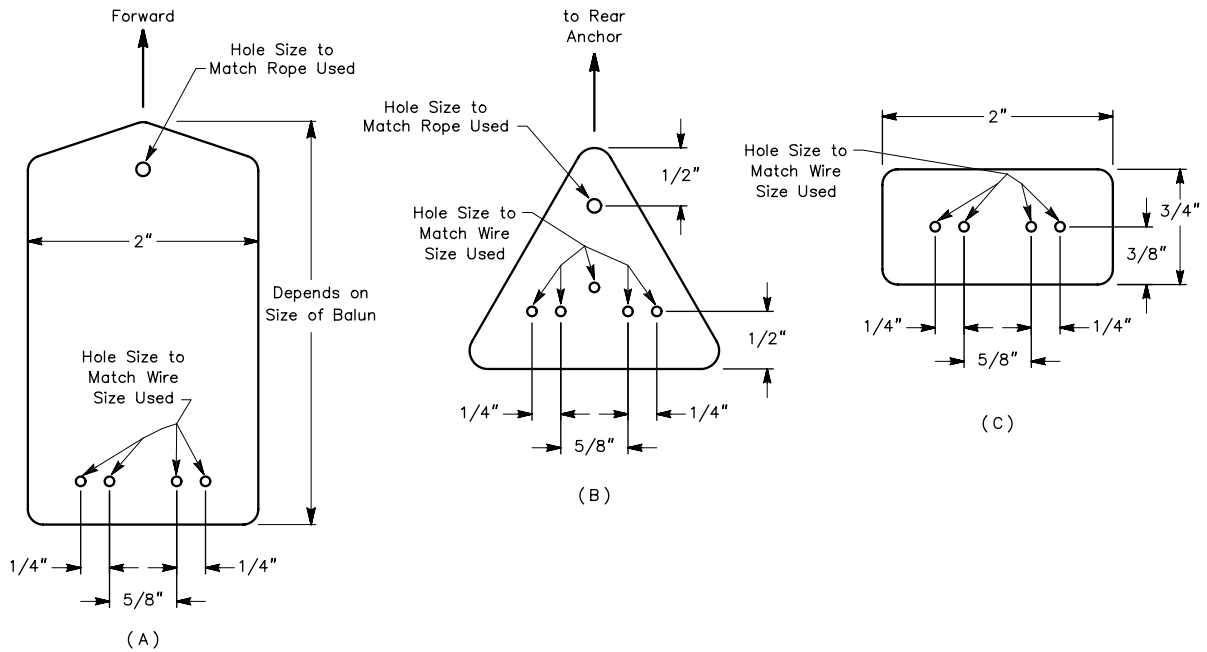
Construction techniques are the same for both the 3.5 and the 7-MHz versions of the array. Once the designs are completed, the next step is to fabricate the fittings; see Fig 16 for details. Cut the wire elements and feed lines to the proper sizes and mark them for identification. After the wires are cut and placed aside, it will be difficult to remember which is which unless they are marked. When you have finished fabricating the connectors and cutting all of the wires, the antenna can be assembled. Use your ingenuity when building one of these antennas; it isn't necessary to duplicate these LPDAs precisely.

The elements are made of standard #14 stranded copper

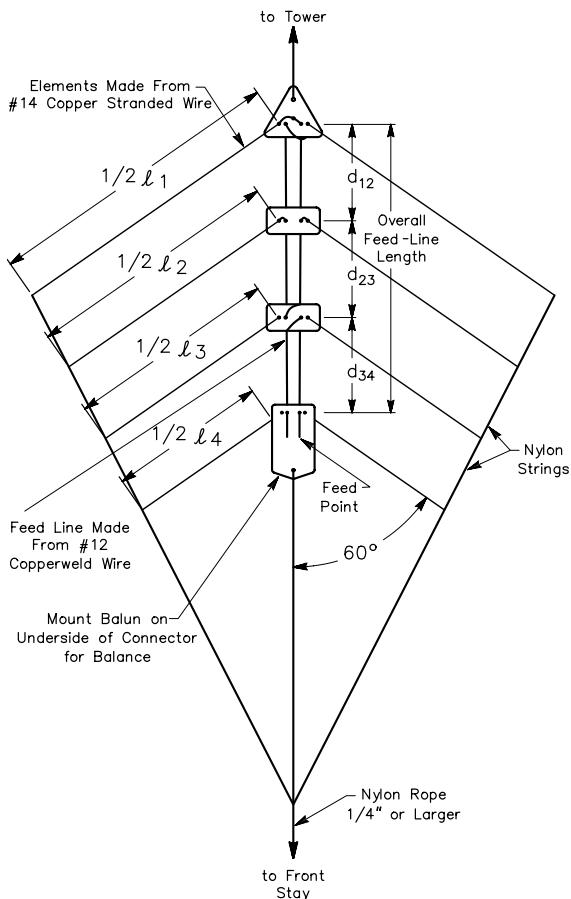
wire. The two parallel feed lines are made of #12 solid copper-coated steel wire, such as Copperweld. Copperweld will not stretch when placed under tension. The front and rear connectors are cut from  $1/2$ -inch thick Lexan sheeting, and the feed-line spacers from  $1/4$ -inch Plexiglas sheeting.

Study the drawings carefully and be familiar with the way the wire elements are connected to the two feed lines, through the front, rear and spacer connectors. Details are sketched in Figs 17 and 18. Connections made in the way shown in the drawings prevent the wire from breaking. All of the rope, string, and connectors must be made of materials that can withstand the effects of tension and weathering. Use nylon rope and strings, the type that yachtsmen use. Fig 15 shows the front stay rope coming down to ground level at a point 120 feet from the base of a 75-foot tower. Space may not be available for this arrangement in all cases. An alternative installation technique is to put a pulley 40 feet up in a tree and run the front stay rope through the pulley and down to ground level at the base of the tree. The front stay rope will have to be tightened with a block and tackle at ground level.

Putting an LPDA together is not difficult if it is assembled in an orderly manner. It is easier to connect the elements to the feeder lines when the feed-line assembly is stretched between two points. Use the tower and a block and tackle. Attaching the rear connector to the tower and assembling the LPDA at the base of the tower makes raising the antenna into place a much simpler task. Tie the rear connector securely to the base of the tower and attach the



**Fig 16—**Pieces for the LPDA that require fabrication. At A is the forward connector, made from 1/2-inch Lexan (polycarbonate). At B is the rear connector, also made from 1/2-inch Lexan. At C is the pattern for the phase-line spacers, made from 1/4-inch Plexiglas. Two spacers are required for the array.



two feeder lines to it. Then thread the two feed-line spacers onto the feed line. The spacers will be loose at this time, but will be positioned properly when the elements are connected. Now connect the front connector to the feed lines. A word of caution: Measure accurately and carefully! Double-check all measurements before you make permanent connections.

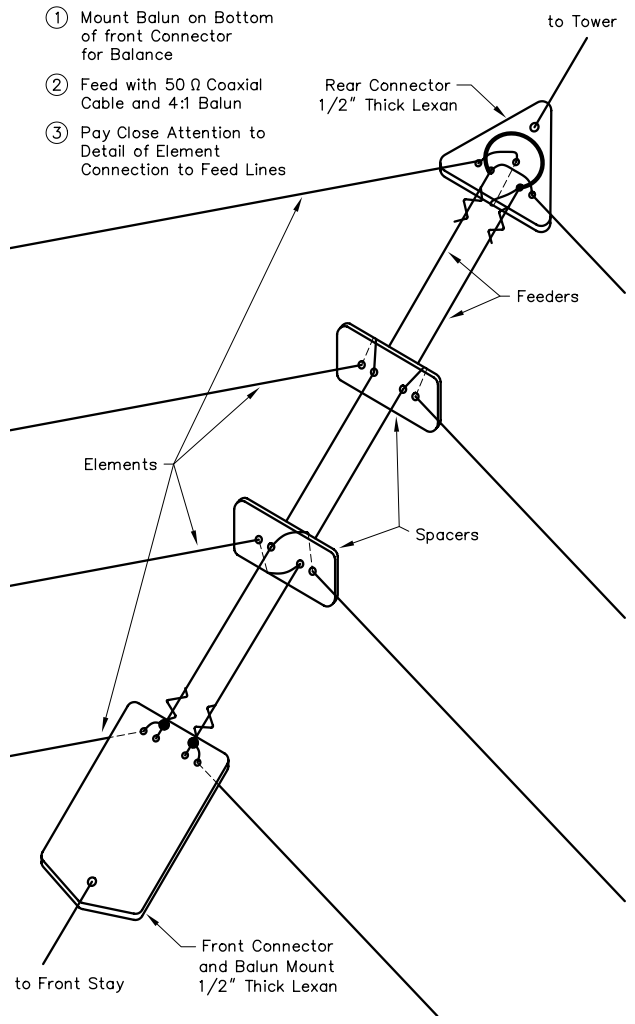
Connect the elements to the feeder lines through their respective plastic connectors, beginning with element 1, then element 2, and so on. Keep all of the element wires securely coiled. If they unravel, you will have a tangled mess of kinked wire. Recheck the element-to-feeder connections to ensure proper and secure junctions. (See Figs 17 and 18.) Once you have completed all of the element connections, attach the 4:1 balun to the underside of the front connector. Connect the feeder lines and the coaxial cable to the balun.

You will need a separate piece of rope and a pulley to raise the completed LPDA into position. First secure the eight element ends with nylon string, referring to Figs 15 and 17. The string must be long enough to reach the tie-down points. Connect the front stay rope to the front connector, and the completed LPDA is now ready to be raised into position. While raising the antenna, uncoil the element wires to prevent their getting away and tangling up

**Fig 17—**The generic layout for the lower HF wire LPDA. Use a 4:1 balun on the forward connector. See Tables 1 and 2 for dimensions.

NOTES:

- ① Mount Balun on Bottom of front Connector for Balance
- ② Feed with 50  $\Omega$  Coaxial Cable and 4:1 Balun
- ③ Pay Close Attention to Detail of Element Connection to Feed Lines



**Fig 18—Details of the electrical and mechanical connections of the elements to the phase-line. Knots in the nylon rope stay line are not shown.**

into a mess. Use care! Raise the rear connector to the proper height and attach it securely to the tower, then pull the front stay rope tight and secure it. Move the elements so they form a 60° angle with the feed lines, in the direction of the front, and space them properly relative to one another. By adjusting the end positions of the elements as you walk back and forth, you will be able to align all the elements properly. Now it is time to hook your rig to the system and make some contacts.

### Performance

The reports received from these LPDAs were compared with an inverted-V dipole. All of the antennas are fixed; the LPDAs radiate to the northeast, and the dipole to the northeast and southwest. The apex of the dipole is at 70 feet, and the 40- and 80-meter LPDAs are at 60 and 50 feet, respectively. Basic array gain was apparent from many of the reports received. During pileups, it was possible to break in with a few tries on the LPDAs, yet it was impossible to break in the same pileups using the dipole. The gain of the LPDAs is several dB over the dipole. For additional gain, experimenters may wish to try a parasitic director about  $\frac{1}{8} \lambda$  ahead of the array. Director length and spacing from the forward LPDA element should be field-adjusted for maximum performance while maintaining the impedance match across each of the bands.

Wire LPDA systems offer many possibilities. They are easy to design and to construct: real advantages in countries where commercially built antennas and parts are not available at reasonable cost. The wire needed can be obtained in all parts of the world, and cost of construction is low. If damaged, the LPDAs can be repaired easily with pliers and solder. For those who travel on DXpeditions where space and weight are large considerations, LPDAs are lightweight but sturdy, and they perform well.

## 5-Band Log Periodic Dipole Array

A rotatable log periodic array designed to cover the frequency range from 13 to 30 MHz is pictured in [Fig 19](#). This is a large array having a free-space gain that varies from 6.6 to over 6.9 dBi, depending upon the operating portion of the design spectrum. This antenna system was originally described by [Peter D. Rhodes, WA4JVE](#), in Nov 1973 *QST*. A measured radiation pattern for the array appears in [Fig 20](#).

The characteristics of this array are:

- 1) Half-power beamwidth, 43° (14 MHz)
- 2) Design parameter  $\tau = 0.9$
- 3) Relative element spacing constant  $\sigma = 0.05$
- 4) Boom length,  $L = 26$  feet
- 5) Longest element  $\lambda_1 = 37$  feet 10 inches. (A tabulation of element lengths and spacings appears in [Table 3](#).)

- 6) Total weight, 116 pounds
- 7) Wind-load area, 10.7 square feet
- 8) Required input impedance (mean resistance),  $R_0 = 72 \Omega$ ,  $Z_t = 6$ -inch jumper #18 wire
- 9) Average characteristic dipole impedance,  $Z_{AV} = 337.8 \Omega$
- 10) Impedance of the feeder,  $Z_0 = 117.1 \Omega$
- 11) Feeder: #12 wire, close spaced
- 12) With a 1:1 toroid balun at the input terminals and a 72- $\Omega$  coax feed line, the maximum SWR is 1.4:1.

The mechanical assembly uses materials readily available from most local hardware stores or aluminum supply houses. The materials needed are given in [Table 4](#). In the construction diagram, [Fig 21](#), the materials are referenced by their respective material list numbers. The

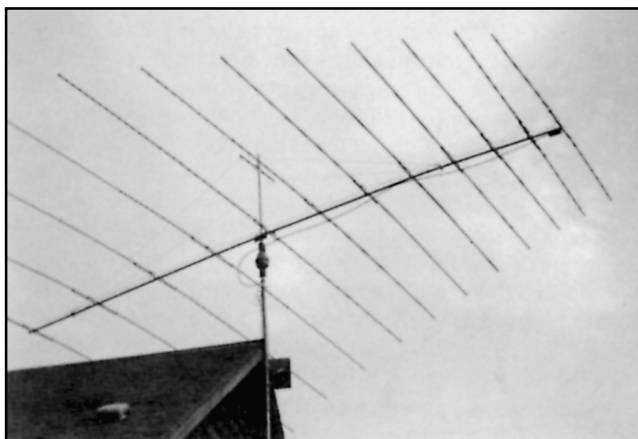


Fig 19—The 13-30 MHz log periodic dipole array.

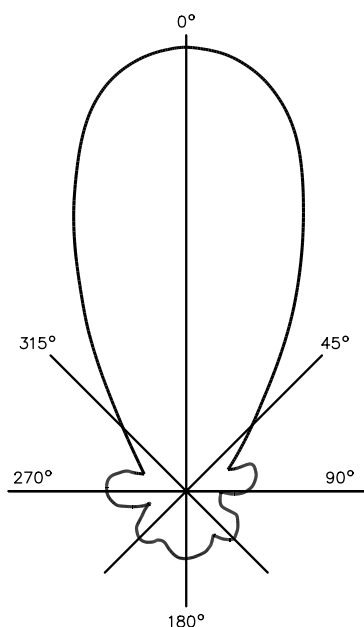


Fig 20—Measured radiation pattern of the 13-30 MHz LPDA. The front-to-back ratio is about 14 dB at 14 MHz and increases to 21 dB at 28 MHz.

photograph shows the overall construction, and the drawings show the details. **Table 5** gives the required tubing lengths to construct the elements.

Experimenters may wish to improve the performance of the array at both the upper and lower frequency ends of the design spectrum so that it more closely approaches the performance in the middle of the design frequency range. The most apt general technique for raising both the gain and the front-to-back ratio at the frequency extremes would be to circularize  $\tau$  as described earlier in this chapter. However, other techniques may also be applied.

**Table 3**  
**13-20 MHz LPDA Dimensions, feet**

Ele. No.	Length	$d_{n-1,n}$ (spacing)	Nearest Resonant
1	37' 10.2"	—	
2	34' 0.7"	3' 9.4" = $d_{12}$	14 MHz
3	30' 7.9"	3' 4.9" = $d_{23}$	
4	27' 7.1"	3' 0.8" = $d_{34}$	
5	24' 10.0"	2' 9.1" = $d_{45}$	18 MHz
6	22' 4.2"	2' 5.8" = $d_{56}$	21 MHz
7	20' 1.4"	2' 2.8" = $d_{67}$	
8	18' 1.2"	2' 0.1" = $d_{78}$	24.9 MHz
9	16' 3.5"	1' 9.7" = $d_{89}$	28 MHz
10	14' 7.9"	1' 7.5" = $d_{9,10}$	
11	13' 2.4"	1' 5.6" = $d_{10,11}$	
12	11' 10.5"	1' 3.8" = $d_{11,12}$	

**Table 4**  
**Materials list: 13-30 MHz LPDA**

Material Description	Quantity
1) Aluminum tubing—0.047" wall thickness	
1"—12' or 6' lengths	126 lineal feet
7/8"—12' lengths	96 lineal feet
7/8"—6' or 12' lengths	66 lineal feet
3/4"—8' lengths	16 lineal feet
2) Stainless-steel hose clamps—2" max	48 ea
3) Stainless-steel hose clamps—1 1/4" max	26 ea
4) TV type U bolts	14 ea
5) U bolts, galv. type	
5/16" x 1 1/2"	4 ea
1/4" x 1"	2 ea
6) 1" ID polyethylene water-service pipe 160 lb/in. <sup>2</sup> test, approx. 1 1/4" OD	20 lineal feet
A) 1 1/4" x 1 1/4" x 1/8" aluminum Angle—6' lengths	30 lineal feet
B) 1" x 1/4" aluminum bar—6' lengths	12 lineal feet
7) 1 1/4" top rail of chain-link fence	26 lineal feet
8) 1:1 toroid balun	1 ea
9) 6-32 x 1" stainless steel screws	24 ea
6-32 stainless steel nuts	48 ea
#6 solder lugs	24 ea
10) #12 copper feeder wire	60 lineal feet
11A) 12" x 8" x 1/4" aluminum plate	1 ea
B) 6" x 4" x 1/4" aluminum plate	1 ea
12A) 3/4" galv. Pipe	3 lineal feet
B) 1" galv. pipe-mast	5 lineal feet
13) Galv. guy wire	50 lineal feet
14) 1/4" x 2" turnbuckles	4 ea
15) 1/4" x 1 1/2" eye bolts	2 ea
16) TV guy clamps and eye bolts	2 ea

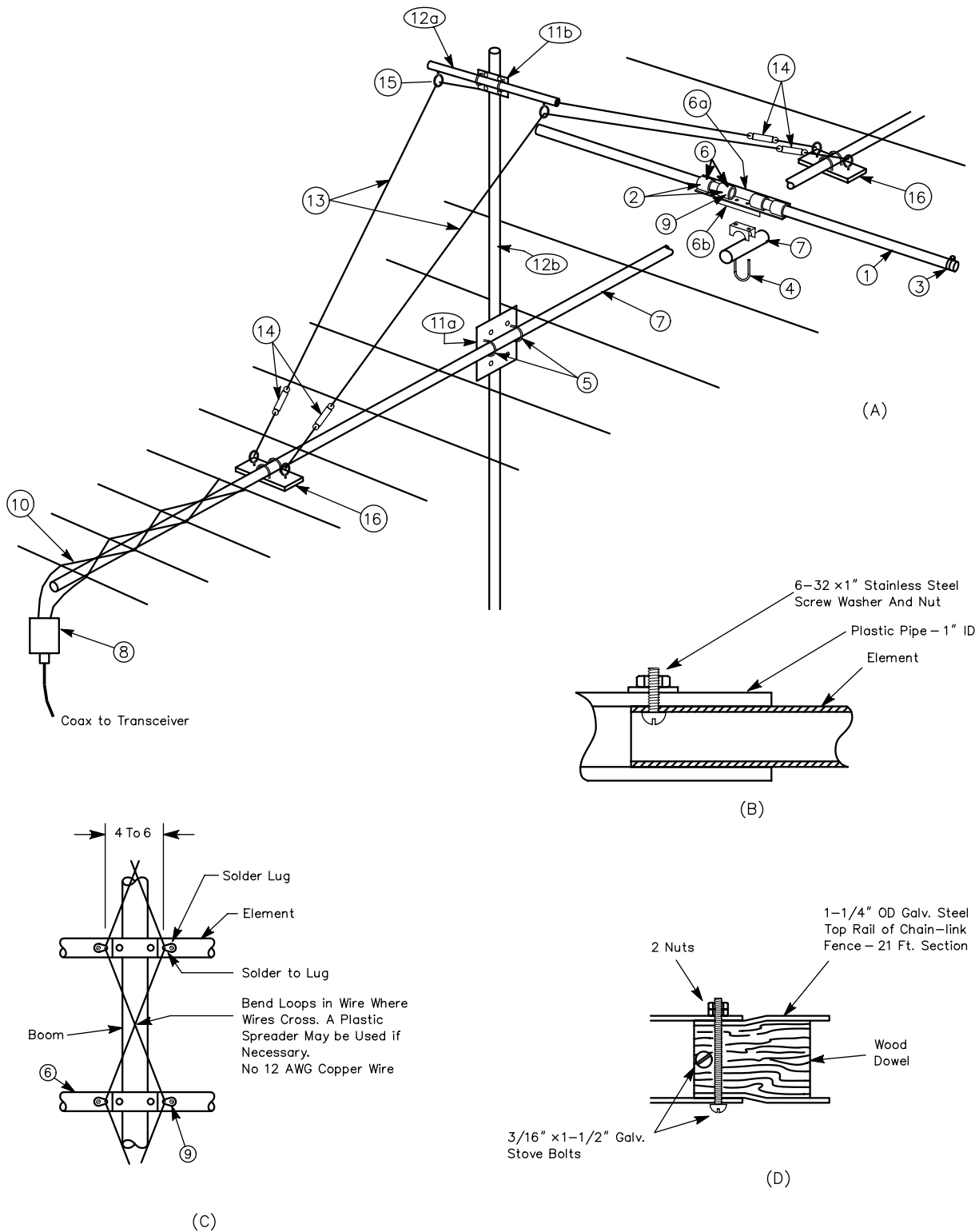


Fig 21—Construction diagrams of the 13-30 MHz LPDA. B and C show the method of making electrical connection between the phase-line and each half-element. D shows how the boom sections are joined.



**Table 5**

**Element Material Requirements: 13-30 MHz LPDA**

Ele. No.	1"		7/8"		3/4"		1 1/4"	1"
	Tubing		Tubing		Tubing		Angle	Bar
	Len.	Qty	Len.	Qty	Len.	Qty	Len.	Len.
1	6'	2	6'	2	8'	2	3'	1'
2	6'	2	12'	2	—	—	3'	1'
3	6'	2	12'	2	—	—	3'	1'
4	6'	2	8.5'	2	—	—	3'	1'
5	6'	2	7'	2	—	—	3'	1'
6	6'	2	6'	2	—	—	3'	1'
7	6'	2	5'	2	—	—	2'	1'
8	6'	2	3.5'	2	—	—	2'	1'
9	6'	2	2.5'	2	—	—	2'	1'
10	3'	2	5'	2	—	—	2'	1'
11	3'	2	4'	2	—	—	2'	1'
12	3'	2	4'	2	—	—	2'	1'

## The Telerana

The Telerana (Spanish for *spider web*) is a rotatable log periodic antenna that is lightweight, easy to construct and relatively inexpensive to build. Designed to cover 12.1 to 30 MHz, it was co-designed by George Smith, W4AEO, and [Ansyl Eckols, YV5DLT](#), and first described by Eckols in *QST* for Jul 1981. Some of the design parameters are as follow.

- 1)  $\tau = 0.9$
- 2)  $\sigma = 0.05$
- 3) Gain = 4.5 to 5.5 dBi (free-space) depending upon frequency
- 4) Feed arrangement: 400- $\Omega$  feeder line with 4:1 balun, fed with 52- $\Omega$  coax. The SWR is 1.5:1 or less in all amateur bands.

The array consists of 13 dipole elements, properly spaced and transposed, along an open wire feeder having an impedance of approximately 400  $\Omega$ . See [Figs 22](#) and [23](#). The array is fed at the forward (smallest) end with a 4:1 balun and RG-8 cable placed inside the front arm and leading to the transmitter. An alternative feed method is to use open wire or ordinary TV ribbon and a tuner, eliminating the balun.

The frame that supports the array ([Fig 24](#)) consists of four 15-foot fiberglass vaulting poles slipped over short nipples at the hub, appearing like wheel spokes ([Fig 25](#)). Instead of being mounted directly into the fiberglass, the hub mounts into short metal tubing sleeves that are inserted into the ends of each arms to prevent crushing and splitting the fiberglass. The necessary holes are drilled to receive the wires and nylon.

A shopping list is provided in [Table 6](#). The center hub is made from a 1 1/4-inch galvanized four-outlet cross or X and four 8-inch nipples ([Fig 25](#)). A 1-inch diameter X may be used alternatively, depending on the diameter of the fiberglass. A hole is drilled in the bottom of the hub to allow

the cable to be passed through after welding the hub to the rotator mounting stub.

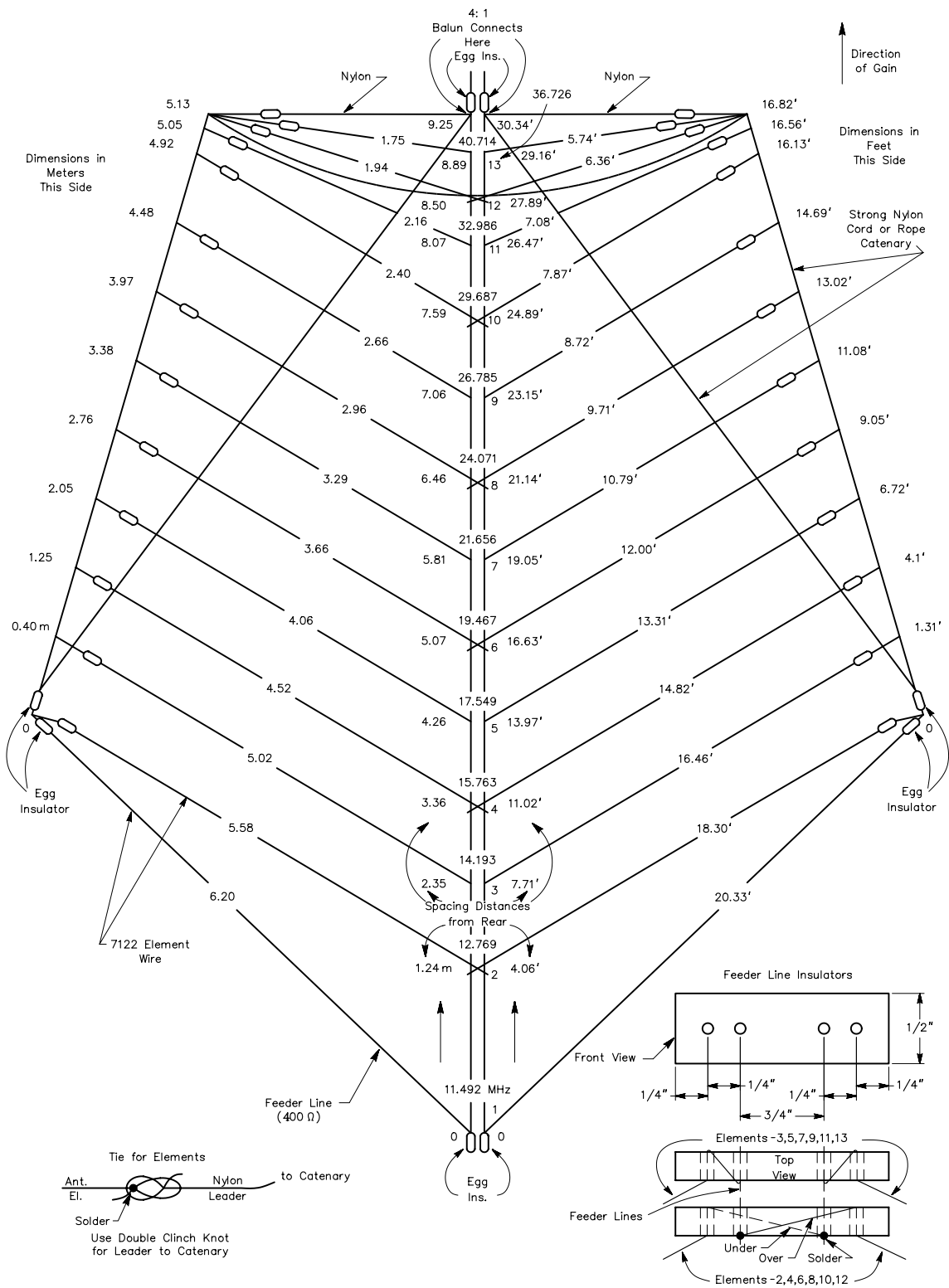
All four arms of the array must be 15 feet long. They should be strong and springy to maintain the tautness of the array. If vaulting poles are used, try to obtain all of them with identical strength ratings.

The forward spreader should be approximately 14.8 feet long. It can be much lighter than the four main arms, but must be strong enough to keep the lines rigid. If tapered, the spreader should have the same measurements from the center to each end. *Do not use metal for this spreader.*

Building the frame for the array is the first construction step. Once the frame is prepared, then everything else can be built onto it. Begin by assembling the hub and the four arms, letting them lie flat on the ground with the rotator stub inserted in a hole in the ground. The tip-to-tip length should be about 31.5 feet each way. A hose clamp is used at each end of the arms to prevent splitting. Place the metal inserts in the outer ends of the arms, with 1 inch protruding. The mounting holes should have been drilled at this point. If the egg insulators and nylon cords are mounted to these tube inserts, the whole antenna can be disassembled simply by bending up the arms and pulling out the inserts with everything still attached.

Choose the arm to be at the front end. Mount two egg insulators at the front and rear to accommodate the inter-element feeder. These insulators should be as close as possible to the ends.

At each end of the cross-arm on top, install a small pulley and string nylon cord across and back. Tighten the cord until the upward bow reaches 3 feet above the hub. All cords will require retightening after the first few days because of stretching. The cross-arm can be laid on its side while



**Fig 22—The overall configuration of the spider web antenna. Nylon monofilament line is used from the ends of the elements to the nylon cords. Use nylon line to tie every point where lines cross. The forward fiberglass feeder lies on the feeder line and is tied to it. Both metric and English measurements are shown, except for the illustration of the feed-line insulator. Use soft-drawn copper or stranded wire for elements 2 through 12. Element 1 should use 7/22 flexible wire or #14 AWG Copperweld.**

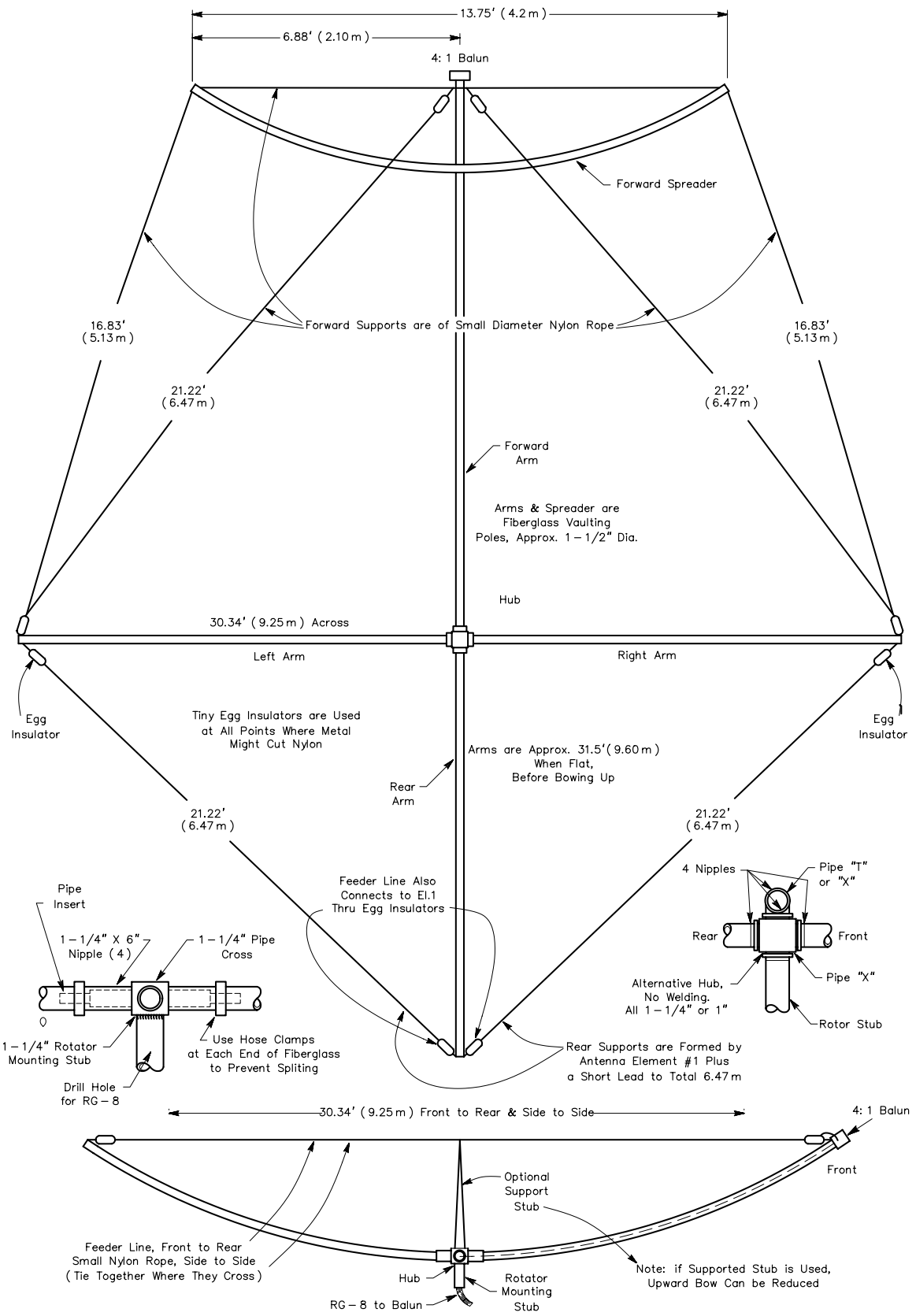
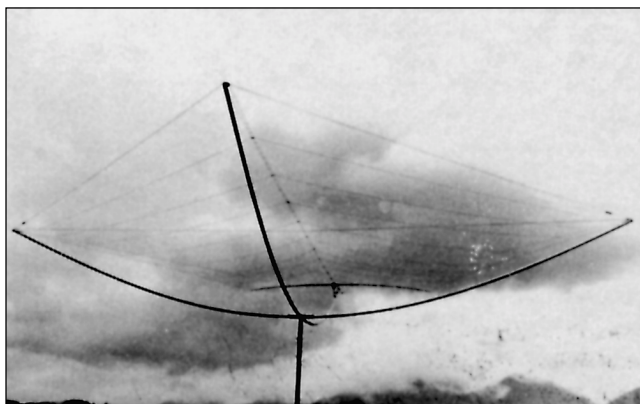
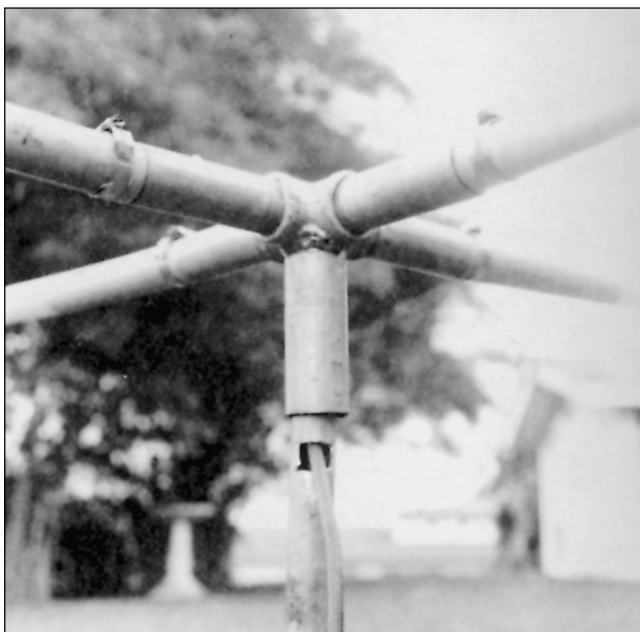


Fig 23—The frame construction of the spider web antenna. Two different hub arrangements are illustrated.



**Fig 24**—Although the spider web antenna resembles a rotatable clothes line, it is much larger, as indicated by Figs 22 and 23. However, the antenna can be lifted by hand.

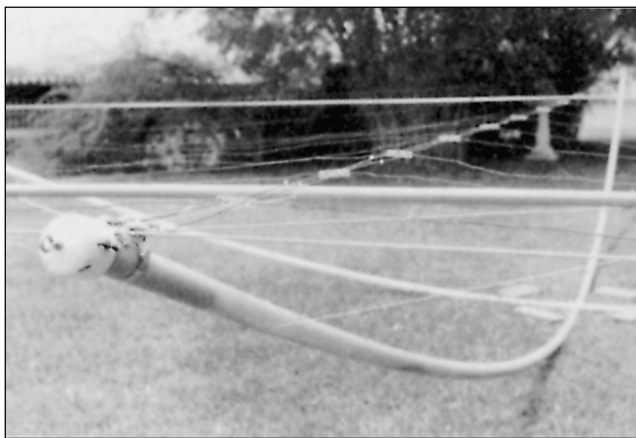


**Fig 25**—The simple arrangement of the spider web antenna hub. See Fig 23 and the text for details.

**Table 6**

**Shopping List for the Telerana**

- 1—1¼-inch galvanized, 4-outlet cross or X.
- 4—8-inch nipples.
- 4—15-foot long arms. Vaulting poles suggested. These must be strong and all of the same strength (150 lb) or better.
- 1—Spreader, 14.8 foot long (must not be metal).
- 1—4:1 balun unless open-wire or TV cable is used.
- 12—Feed-line insulators made from Plexiglas or fiberglass.
- 36—Small egg insulators.
- 328 feet copper wire for elements; flexible 7/22 is suggested.
- 65.6 feet (20 m) #14 Copperweld wire for interelement feed line.
- 164 feet (50 m) strong 1/8-inch dia cord.
- 1—Roll of nylon monofilament fishing line, 50 lb test or better.
- 4—Metal tubing inserts go into the ends of the fiberglass arms.
- 2—Fiberglass fishing-rod blanks.
- 4—Hose clamps.



**Fig 26**—The elements, balun, transmission line and main bow of the spider web antenna.

preparing the feeder line. For the front-to-rear bowstring it is important to use a wire that will not stretch, such as #14 Copperweld. This bowstring is actually the inter-element transmission line. See Fig 26.

Secure the rear ends of the feeder to the two rear insulators, soldering the wrap. Before securing the fronts, slip the 12 insulators onto the two feed lines. A rope can be used temporarily to form the bow and to aid in mounting the feeder line. The end-to-end length of the feeder should be 30.24 feet.

Now lift both bows to their upright position and tie the feeder line and the cross-arm bowstring together where they

cross, directly over and approximately 3 feet above the hub.

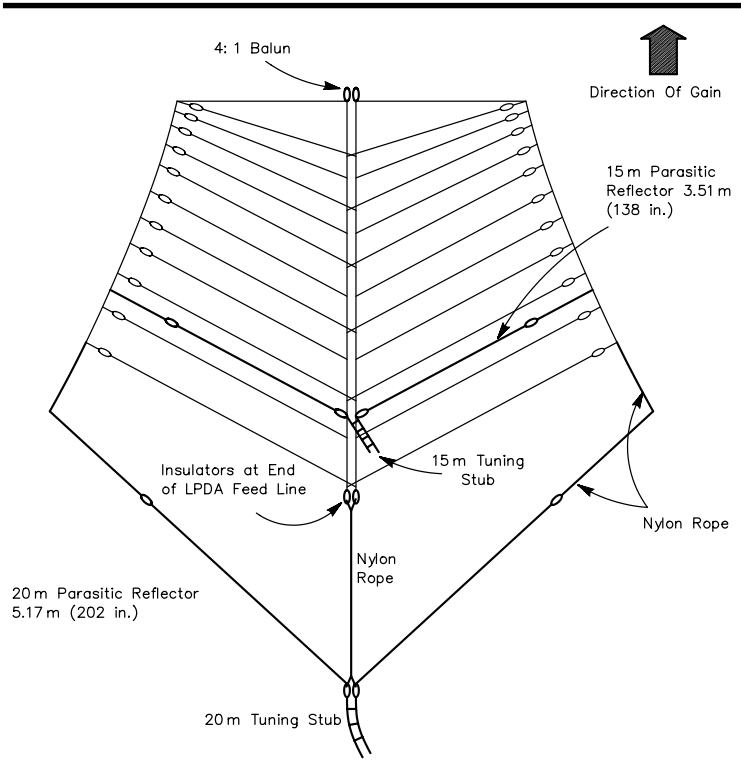
The next step is to install the number 1 rear element from the rear egg insulators to the right and left cross-arms using other egg insulators to provide the proper element length. Be sure to solder the element halves to the transmission line. Complete this portion of the construction by installing the nylon cord catenaries from the front arm to the cross-arm tips. Use egg insulators where needed to prevent cutting the nylon cords.

When preparing the fiberglass forward spreader, keep in mind that it should be 14.75 feet long before bowing and is approximately 13.75 feet across when bowed. Secure the

## Improving the Telerana

In *The ARRL Antenna Compendium Vol 4*, [Markus Hansen, VE7CA](#), described how he modified the Telerana to improve the front-to-back ratio on 20 and 15 meters. In addition, he added a trapped 30/40-meter dipole that functions as a top truss system to stabilize the modified Telerana in strong uprising winds that otherwise could turn the antenna into an “inside-out umbrella.”

**Fig A** shows the layout for the modified Telerana, and **Table A** lists the lengths and spacings for the #14 wire elements. Note that VE7CA used tuning stubs to tweak the 15 and 20-meter reflector wires for best rearward pattern. The construction techniques used by VE7CA are the same as for the original Telerana. **Fig B** shows a side view of the additional 40/30-meter-dipole truss system.

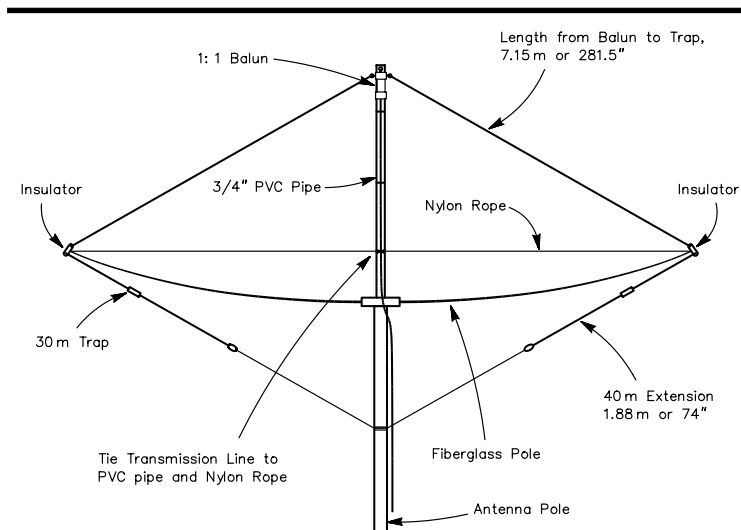


**Table A**  
Element Lengths and Spacings,  
in Inches

Element Number	Element Length (inches)	Total Distance (inches)
R1	202.0	0.0
L1	210.1	102.0
L2	191.2	140.7
R2	138.0	158.3
L3	174.0	175.9
L4	158.3	207.9
L5	144.1	237.0
L6	131.1	261.5
L7	119.3	285.6
L8	108.6	307.6
L9	98.8	327.6
L10	89.9	345.8
L11	82.4	364.5

Note: the reflector lengths do not include the length of the tuning stubs.

**Fig A**—Physical layout of modified Telerana with 20 and 15-meter reflectors added (in place of first two elements in original Telerana). Note the tuning stubs for the added reflectors.



**Fig B**—Side view of 30/40-meter addition to the modified Telerana, using  $3/4$ -inch PVC pipe as a vertical stabilizer and support for the 30/40-meter trapped dipole.

center of the bowstring to the end of the front arm. Lay the spreader on top of the feed line, then tie the feeder to the spreader with nylon fish line. String the catenary from the spreader tips to the cross-arm tips.

At this point of assembly, prepare antenna elements 2 through 13. There will be two segments for each element. At the outer tip make a small loop and solder the wrap. The loop will be for the nylon leader. Measure the length plus 0.4 inch for wrapping and soldering the element segment to the feeder. Seven-strand #22 antenna wire is suggested for the element wires. Slide the feed-line insulators to their proper position and secure them temporarily.

The drawings show the necessary transposition scheme. Each element half of elements 1, 3, 5, 7, 9, 11 and 13 is connected to its own side of the feeder, while elements 2, 4, 6, 8, 10 and 12 cross over to the opposite side of the transmission line.

There are four holes in each of the transmission-line insulators (see Fig 22). The inner holes are for the transmission line, and the outer ones are for the elements. Since the array elements are slanted forward, they should pass through the insulator from front to back, then back over the insulator to the front side and be soldered to the transmission line. The small drawings of Fig 22 show the details of the element transpositions.

Everywhere that lines cross, tie them together with nylon line, including all copper-nylon and nylon-nylon junctions. Careful tying makes the array much more rigid. However, all elements should be mounted loosely before you try to align the whole thing. Tightening any line or element affects all the others. There will be plenty of walking back and forth before the array is aligned properly. Expect the array to be firm but not extremely taut.

## The Pounder: A Single-Band 144-MHz LPDA

The 4-element Pounder LPDA pictured in Fig 27 was developed by Jerry Hall, K1TD, for the 144-148 MHz band. Because it started as an experimental antenna, it utilizes some unusual construction techniques. However, it gives a very good account of itself, exhibiting a theoretical free-space gain of about 7.2 dBi and a front-to-back ratio of 20 dB or better. The Pounder is small and light. It weighs just 1 pound, and hence its name. In addition, as may be seen in Fig 28, it can be disassembled and reassembled quickly, making it an excellent antenna for portable use. This array also serves well as a fixed-station antenna, and may be changed easily to either vertical or horizontal polarization.

The antenna feeder consists of two lengths of  $\frac{1}{2} \times \frac{1}{2} \times \frac{1}{16}$ -inch angle aluminum. The use of two facing flat surfaces permits the builder to obtain a lower characteristic impedance than can be obtained from round conductors with the same spacing. The feeder also serves as the boom for the Pounder. In the first experimental model, the array contained only two elements with a spacing of 1 foot, so a boom length of 1 foot was the primary design requirement for the 4-element version. Table 7 gives the calculated design data for the 4-element array.

### Construction

You can see the general construction approach for the Pounder in the photographs. Drilled and tapped pieces of Plexiglas sheet,  $\frac{1}{4}$ -inch thick, serve as insulating spacers for the angle aluminum feeder. Two spacers are used, one near the front and one near the rear of the array. Four #6-32  $\times \frac{1}{4}$ -inch pan head screws secure each aluminum angle section to the Plexiglas spacers, as shown in Figs 29 and 30.

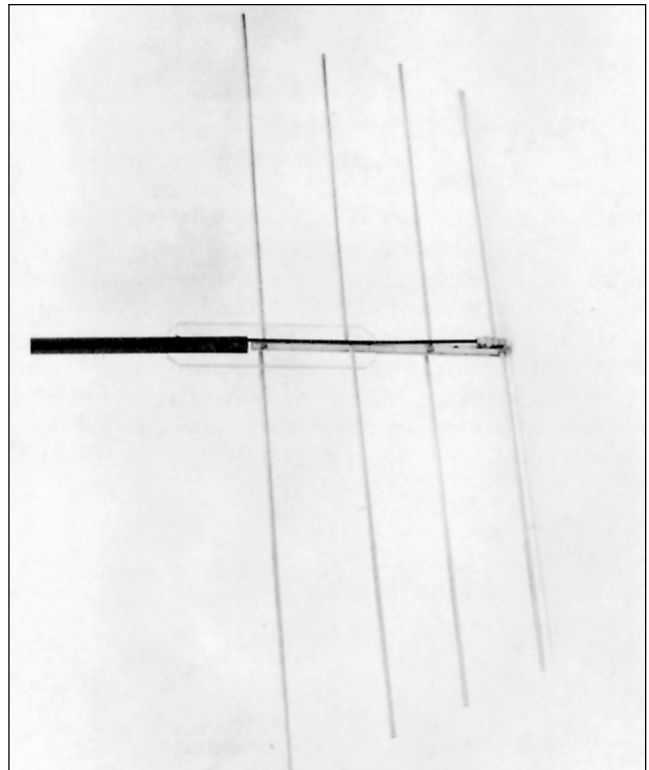
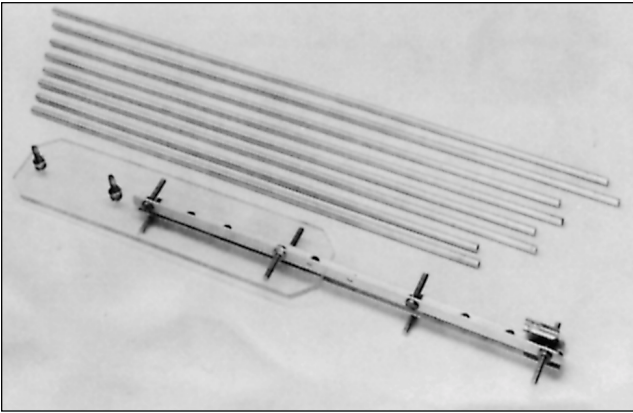


Fig 27—The 144 MHz Pounder. The boom extension at the left of the photo is a 40-inch length of slotted PVC tubing,  $\frac{7}{8}$ -inch outer diameter. The tubing may be clamped to the side of a tower or attached to a mast with a small boom-to-mast plate. Rotating the tubing at the clamp will provide for either vertical or horizontal polarization.



**Fig 28**—One end of each half element is tapped to fasten onto boom-mounted screws. Disassembly of the array consists of merely unscrewing 8 half elements from the boom. The entire disassembled array creates a small bundle only 21 inches long.

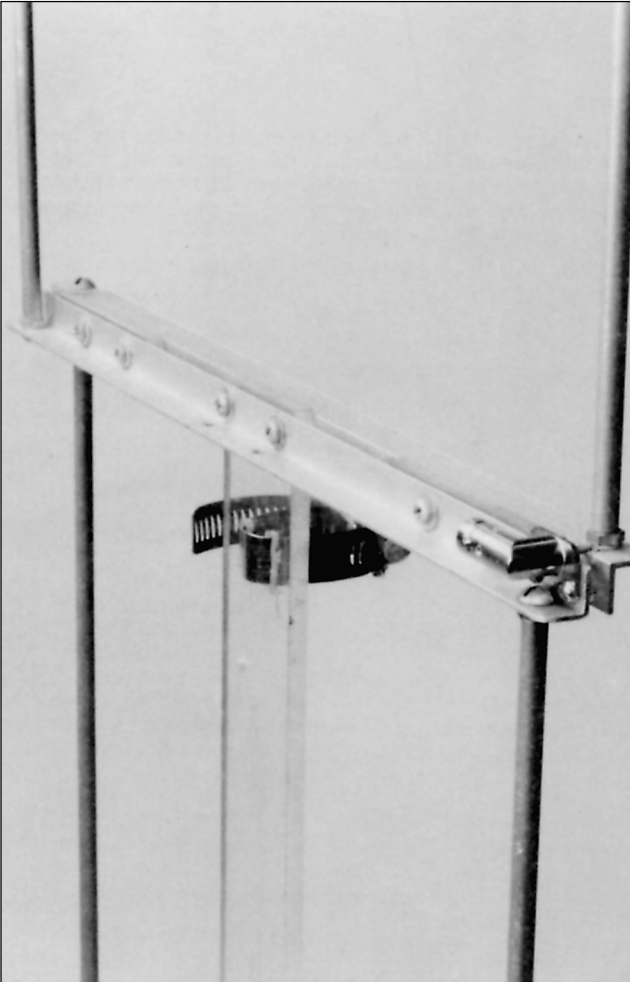
**Table 7**  
**Design Parameters for the 144-MHz Pounder**

$f_1 = 143 \text{ MHz}$	Element lengths:
$f_n = 148 \text{ MHz}$	$\ell_1 = 3.441 \text{ feet}$
$B = 1.0350$	$\ell_2 = 3.165 \text{ feet}$
$\tau = 0.92$	$\ell_3 = 2.912 \text{ feet}$
$\sigma = 0.053$	$\ell_4 = 2.679 \text{ feet}$
Gain = 7.2 dBi = 5.1 dBd	Element spacings:
$\cot \alpha = 2.6500$	$d_{12} = 0.365 \text{ feet}$
$B_{ar} = 1.2306$	$d_{23} = 0.336 \text{ feet}$
$B_s = 1.2736$	$d_{34} = 0.309 \text{ feet}$
$L = 0.98 \text{ feet}$	Element diameters:
$N = 3.90 \text{ elements (increase to 4)}$	All = 0.25 inches
$Z_t = \text{none}$	$\ell/\text{diameter ratios:}$
$R_0 = 52 \Omega$	$\ell_4/\text{diam}_4 = 128.6$
$Z_{AV} = 312.8 \Omega$	$\ell_3/\text{diam}_3 = 139.8$
$\sigma' = 0.05526$	$\ell_2/\text{diam}_2 = 151.9$
$Z_0 = 75.1 \Omega$	$\ell_1/\text{diam}_1 = 165.1$

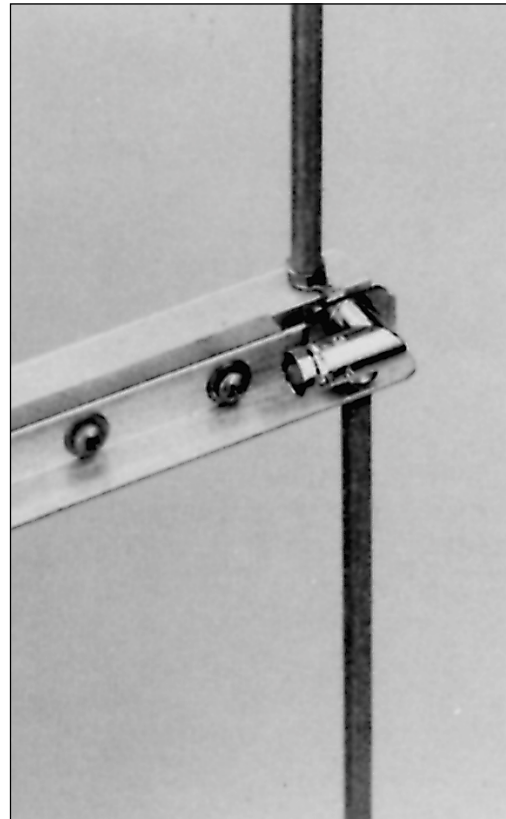
Antenna feeder:  $1/2 \times 1/2 \times 1/16$ " angle aluminum spaced  $1/4$ "

Balun: 1:1 (see text)

Feed line: 52- $\Omega$  coax (see text)



**Fig 29**—A close-up view of the boom, showing an alternative mounting scheme. This photo shows an earlier 2-element array, but the boom construction is the same for 2 or 4 elements. See the text for details.



**Fig 30**—The feed arrangement, using a right-angle chassis-mounted BNC connector, modified by removing a portion of the flange. A short length of bus wire connects the center pin to the opposite feeder conductor.

Use flat washers with each screw to prevent it from touching the angle stock on the opposite side of the spacer. Be sure the screws are not so long as to short out the feeder! A clearance of about  $1/16$  inch is sufficient. If you have doubts about the screw lengths, check the assembled boom for a short with your ohmmeter on a Megohm range.

Either of two mounting techniques may be used for the Pounder. As shown in Figs 27 and 28, the rear spacer measures  $10 \times 2\frac{1}{2}$  inches, with  $45^\circ$  corners to avoid sharp points. This spacer also accommodates a boom extension of PVC tubing, which is attached with two #10-32  $\times$  1-inch screws. This tubing provides for side mounting the Pounder away from a mast or tower.

An alternative support arrangement is shown in Fig 29. Two  $\frac{1}{2} \times 3$ -inch Plexiglas spacers are used at the front and rear of the array. Each spacer has four holes drilled  $\frac{5}{8}$  inch apart and tapped with #6-32 threads. Two screws enter each spacer from either side to make a tight aluminum-Plexiglas-aluminum sandwich. At the center of the boom, secured with only two screws, is a  $2 \times 18$ -inch strip of  $\frac{1}{4}$ -inch Plexiglas. This strip is slotted about 2 inches from each end to accept hose clamps for mounting the Pounder atop a mast. As shown, the strip is attached for vertical polarization. Alternate mounting holes, visible on the now-horizontal lip of the angle stock, provide for horizontal polarization. Although sufficient, this mounting arrangement is not as sturdy as that shown in Fig 27.

The elements are lengths of thick-wall aluminum tubing,  $\frac{1}{4}$ -inch OD. The inside wall conveniently accepts a #10-32 tap. The threads should penetrate the tubing to a depth of at least 1 inch. Eight #10-32  $\times$  1-inch screws are attached to the boom at the proper element spacings and held in place with #10-32 nuts, as shown in Fig 28. For assembly, the elements are then simply screwed into place.

Note that with this construction arrangement, the two halves of any individual element are not precisely collinear; their axes are offset by about  $\frac{3}{4}$  inch. This offset does not seem to affect performance.

### The Feed Arrangement

Use care initially in mounting and cutting the elements to length. To obtain the  $180^\circ$  crossover feed arrangement, the element halves from a single section of the feeder/boom must alternate directions. That is, for half-elements attached to one of the two pieces of angle stock, elements 1 and 3 will point to one side, and elements 2 and 4 to the other. This arrangement may be seen by observing the element-mounting screws in Fig 28. Because of this mounting scheme, the length of tubing for an element “half” is not

simply half of the length given in Table 7. After final assembly, halves for elements 2 and 4 will have a slight overlap, while elements 1 and 3 are extended somewhat by the boom thickness. The best procedure is to cut each assembled element to its final length by measuring from tip to tip.

The Pounder may be fed with RG-58 or RG-59 coax and a BNC connector. A modified right-angle chassis-mount BNC connector is attached to one side of the feeder/boom assembly for cable connection, Fig 30. The modification consists of cutting away part of the mounting flange that would otherwise protrude from the boom assembly. This leaves only two mounting-flange holes, but these are sufficient for a secure mount. A short length of small bus wire connects the center pin to the opposite side of the feeder, where it is secured under the mounting-screw nut for the shortest element.

For operation, you may secure the coax to the PVC boom extension or to the mast with electrical tape. You should use a balun, especially if the Pounder is operated with vertical elements. A choke type of balun is satisfactory, formed by taping 6 turns of the coax into a coil of 3 inches diameter, but a bead balun is preferred (see Chapter 26). The balun should be placed at the point where the coax is brought away from the boom. If the mounting arrangement of Fig 29 is used with vertical polarization, a second balun should be located approximately  $\frac{1}{4}$  wavelength down the coax line from the first. This will place it at about the level of the lower tips of the elements. For long runs of coax to the transmitter, a transition from RG-58 to RG-8 or from RG-59 to RG-9 is suggested, to reduce line losses. Make this transition at some convenient point near the array.

No shorting feeder termination is used with the array described here. The antenna feeder (phase-line)  $Z_0$  of this array is in the neighborhood of  $120 \Omega$ , and with a resulting feed-point impedance of about  $72 \Omega$ . The theoretical mean SWR with  $52 \Omega$  line is  $72/52$  or 1.4 to 1. Upon array completion, the measured SWR ( $52\text{-}\Omega$  line) was found to be relatively constant across the band, with a value of about 1.7 to 1. The Pounder offers a better match to  $72\text{-}\Omega$  coax.

Being an all-driven array, the Pounder is more immune to changes in feed-point impedance caused by nearby objects than is a parasitic array. This became obvious during portable use when the array was operated near trees and other objects... the SWR did not change noticeably with antenna rotation toward and away from those objects. Consequently, the Pounder should behave well in a restricted environment, such as an attic. Weighing just one pound, this array indeed does give a good account of itself.



# Log Periodic-Yagi Arrays

Several possibilities exist for constructing high-gain arrays that use the log periodic dipole array concept. One technique is to add parasitic elements to the LPDA to increase both the gain and the front-to-back ratio for a specific frequency within the passband of the LPDA. The LPDA-Yagi combination is simple in concept. It utilizes an LPDA group of driven elements, along with parasitic elements at normal Yagi spacings from the active elements of the LPDA.

The LPDA-Yagi combinations are endless. An example of a single-band high-gain design is a 2- or 3-element LPDA for 21.0 to 21.45 MHz with the addition of two or three parasitic directors and one parasitic reflector. The name Log-Yag (log-cell Yagi) array has been coined for these hybrid antennas. The LPDA portion of the array is of the usual design to cover the desired bandwidth, and standard Yagi design procedures are used for the parasitic elements. Information in this section is based on a Dec 1976, *QST* article by P. D. Rhodes, K4EWG, and J. R. Painter, W4BBP, "The Log-Yag Array."

## THE LOG-YAG ARRAY

The Log-Yag array, with its added parasitic elements, provides higher gain and greater directivity than would be realized with the LPDA alone. Yagi arrays require a long boom and wide element spacing for wide bandwidth and high gain, because the Q of the Yagi system increases as the number of elements is increased or as the spacing between adjacent elements is decreased. An increase in the Q of the Yagi array means that the total operating bandwidth of the array is decreased, and the gain and front-to-back ratio specified in the design are obtainable only over small portions of the band. [Older Yagi designs did indeed exhibit the limitations mentioned here. But modern, computer-aided design has resulted in wideband Yagis, provided that sufficient elements are used on the boom to allow stagger tuning for wide-band coverage. See [Chapter 11](#).—*Ed.*]

The Log-Yag system overcomes this difficulty by using a multiple driven element cell designed in accordance with the principles of the log periodic dipole array. Since this log cell exhibits both gain and directivity by itself, it is a more effective wide-band radiator than a simple dipole driven element. The front-to-back ratio and gain of the log cell can then be improved with the addition of a parasitic reflector and director.

It is not necessary for the parasitic element spacings to be large with respect to wavelength, since the log cell is the determining factor in the array bandwidth. As well, the element spacings within the log cell may be small with respect to a wavelength without appreciable deterioration of the cell gain. For example, decreasing the relative spacing constant ( $\sigma$ ) from 0.1 to 0.05 will decrease the array gain by less than 1 dB.

## A Practical Example

The photographs and figures show a Log-Yag array for the 14-MHz amateur band. The array design takes the form of a 4-element log cell, a parasitic reflector spaced at  $0.085 \lambda_{\max}$ , and a parasitic director spaced at  $0.15 \lambda_{\max}$  (where  $\lambda_{\max}$  is the longest free-space wavelength within the array passband). Array gain is almost unaffected with reflector spacings from  $0.08 \lambda$  to  $0.25 \lambda$ , and the increase in boom length is not justified. The function of the reflector is to improve the front-to-back ratio of the log cell, while the director sharpens the forward lobe and decreases the half-power beamwidth. As the spacing between the parasitic elements and the log cell decreases, the parasitic elements must increase in length.

The log cell is designed to meet upper and lower band limits with  $\sigma = 0.05$ . The design parameter  $\tau$  is dependent on the structure bandwidth,  $B_s$ . When the log periodic design parameters have been found, the element length and spacings can be determined.

Array layout and construction details can be seen in [Figs 31, 32, 33](#) and [34](#). Characteristics of the array are given in [Table 8](#).

The method of feeding the antenna is identical to that of feeding the log periodic dipole array without the parasitic elements. As shown in [Fig 31](#), a balanced feeder is required for each log-cell element, and all adjacent elements are fed

**Table 8**  
**Log-Yag Array Characteristics**

1) Frequency range	14 to 14.35 MHz
2) Operating bandwidth	$B = 1.025$
3) Design parameter	$\tau = 0.946657$
4) Apex half angle	$\alpha = 14.921^\circ$ ; $\cot \alpha = 3.753$
5) Half-power beamwidth	$42^\circ$ (14 to 14.35 MHz)
6) Bandwidth of structure	$B_s = 1.17875$
7) Free-space wavelength	$\lambda_{\max} = 70.28$ feet
8) Log cell boom length	$L = 10.0$ feet
9) Longest log element	$\ell_1 = 35.14$ feet (a tabulation of element lengths and spacings is given in <a href="#">Table 9</a> )
10) Forward gain (free space)	8.2 dBi
11) Front-to-back ratio	32 dB (theoretical)
12) Front-to-side ratio	45 dB (theoretical)
13) Input impedance	$Z_0 = 37 \Omega$
14) SWR	1.3 to 1 (14 to 14.35 MHz)
15) Total weight	96 pounds
16) Wind-load area	8.5 sq feet
17) Reflector length	36.4 feet at 6.0 foot spacing
18) Director length	32.2 feet at 10.5 foot spacing
19) Total boom length	26.5 feet

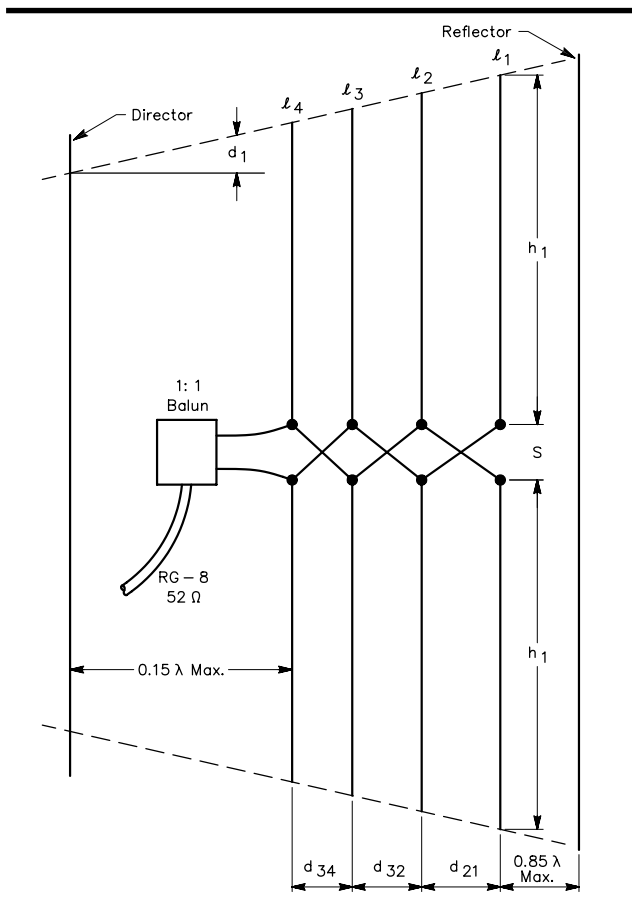


Fig 31—Layout of the Log-Yag array.

Table 9  
Log-Yag Array Dimensions

Element	Length Feet	Spacing Feet
Reflector	36.40	6.00 (Ref. to $l_1$ )
$l_1$	35.14	3.51 ( $d_{12}$ )
$l_2$	33.27	3.32 ( $d_{23}$ )
$l_3$	31.49	3.14 ( $d_{34}$ )
$l_4$	29.81	10.57 ( $l_4$ to dir.)
Director	32.20	

with a  $180^\circ$  phase shift by alternating connections. Since the Log-Yag array will be covering a relatively small bandwidth, the radiation resistance of the narrow-band log cell will vary from 80 to 90  $\Omega$  (tubing elements) depending on the operating bandwidth. The addition of parasitic elements lowers the log-cell radiation resistance. Hence, it is recommended that a 1:1 balun be connected at the log-cell input terminals and 50- $\Omega$  coaxial cable be used for the feed line.

The measured radiation resistance of the 14-MHz Log-Yag is 37  $\Omega$  over the frequency range from 14.0 to 14.35 MHz. It is assumed that tubing elements will be used. However, if a wire array is used, then the radiation resistance  $R_0$  and antenna-feeder input impedance  $Z_0$  must be calculated so that the proper balun and coax may be used. The procedure is outlined in detail in an earlier part of this chapter. However, programs such as [LPCAD28](#) are also suitable to automate the calculations.

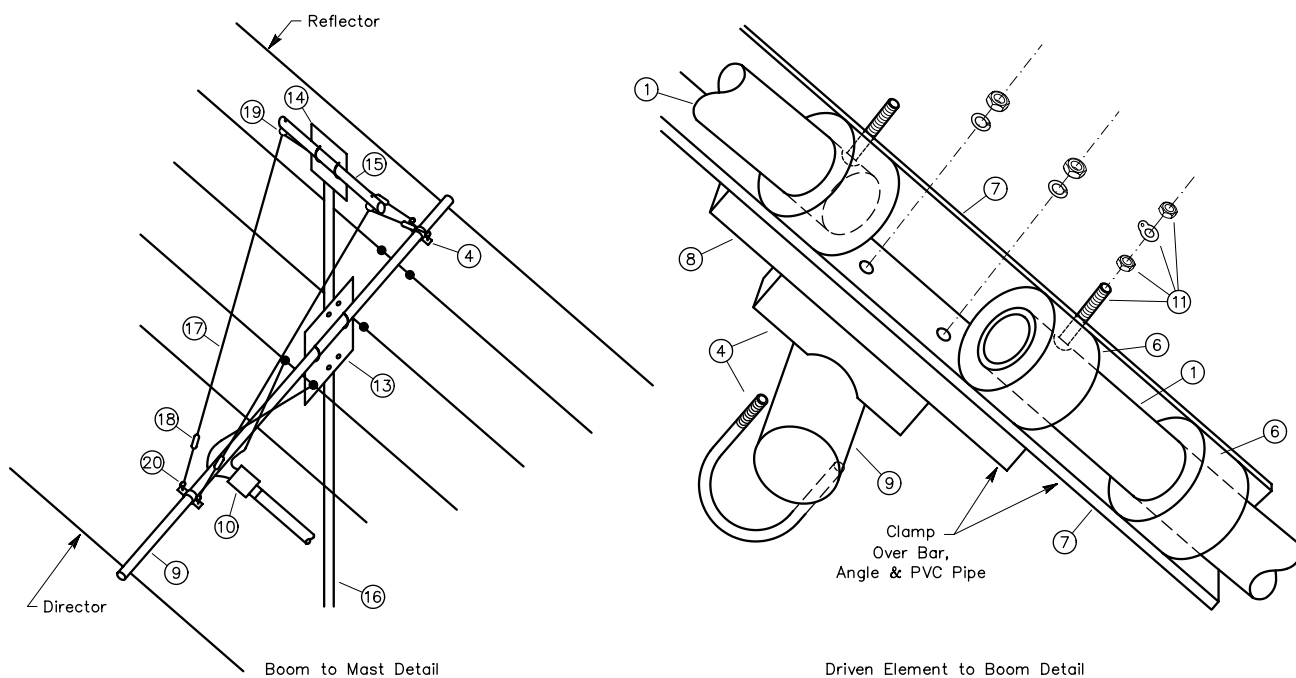
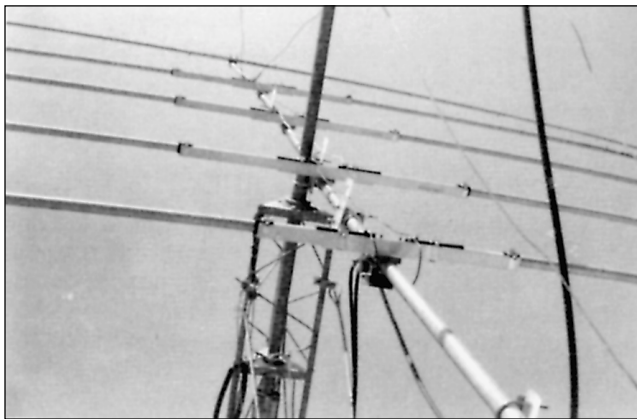


Fig 32—Assembly details. The numbered components refer to [Table 11](#).

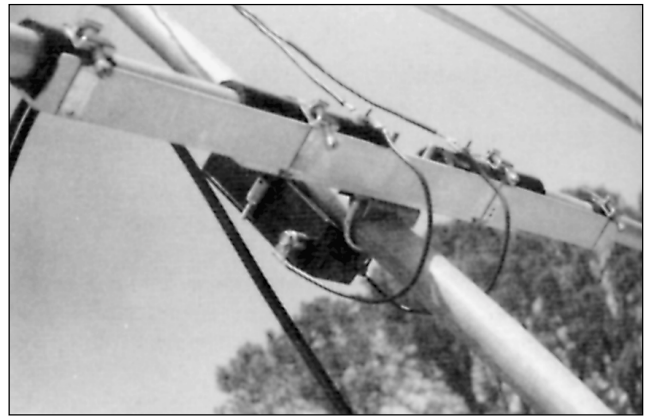
**Table 10**

**Element Material Requirements: Log-Yag Array**

	1-in. Tubing		7/8-in. Tubing		3/4-in. Tubing		1 1/4-in. Angle	1 1/4-in. Bar
	Len. Feet	Qty	Len. Feet	Qty	Len. Feet	Qty	Len. Feet	Len. Feet
Reflector	12	1	6	2	8	2	None	None
ℓ1	6	2	6	2	8	2	3	1
ℓ2	6	2	6	2	8	2	3	1
ℓ3	6	2	6	2	6	2	3	1
ℓ4	6	2	6	2	6	2	3	1
Director	12	1	6	2	6	2	None	None



**Fig 33**—The attachment of the elements to the boom.



**Fig 34**—Looking from the front to the back of the Log-Yag array. A truss provides lateral and vertical support.

**Table 11**

**Materials List, Log-Yag Array**

- 1) Aluminum tubing—0.047 in. wall thickness
  - 1 in.—12 ft lengths, 24 lin. ft
  - 1 in.—12 ft or 6 ft lengths, 48 lin. ft
  - 7/8 in.—12 ft or 6 ft lengths, 72 lin. ft
  - 3/4 in.—8 ft lengths, 48 lin. ft
  - 3/4 in.—6 ft lengths, 36 lin. ft
- 2) Stainless steel hose clamps—2 in. max, 8 ea
- 3) Stainless steel hose clamps—1 1/4 in. max, 24 ea
- 4) TV-type U bolts—1 1/2 in., 6 ea
- 5) U bolts, galv. type: 5/16 in. × 1 1/2 in., 6 ea
- 5A) U bolts, galv. type: 1/4 in. × 1 in., 2 ea
- 6) 1 in. ID water-service polyethylene pipe 160 lb/in.<sup>2</sup> test, approx. 1 3/8 in. OD, 7 lin. ft
- 7) 1 1/4 in. × 1 1/4 in. × 1/8 in. aluminum angle—6 ft lengths, 12 lin. ft
- 8) 1 in. × 1/4 in. × 1/4 in. aluminum angle—6 ft lengths, 6 lin. ft
- 9) 1 1/4 in. top rail of chain-link fence, 26.5 lin. ft
- 10) 1:1 toroid balun, 1 ea
- 11) No. 6-32 × 1 in. stainless steel screws, 8 ea  
No. 6-32 stainless steel nuts, 16 ea  
No. 6 solder lugs, 8 ea
- 12) #12 copper feed wire, 22 lin. ft
- 13) 12 in. × 6 in. × 1/4 in. aluminum plate, 1 ea
- 14) 6 in. × 4 in. × 1/4 in. aluminum plate, 1 ea
- 15) 3/4 in. galv. pipe, 3 lin. ft
- 16) 1 in. galv. pipe—mast, 5 lin. ft
- 17) Galv. guy wire, 50 lin. ft
- 18) 1/4 in. × 2 in. turnbuckles, 4 ea
- 19) 1/4 in. × 1 1/2 in. eye bolts, 2 ea
- 20) TV guy clamps and eyebolts, 2 ea

**Table 9** has array dimensions. **Tables 10** and **11** contain lists of the materials necessary to build the Log-Yag array.

**BIBLIOGRAPHY**

Source material and more extended discussion of the topics covered in this chapter can be found in the references listed below and in the textbooks listed at the end of [Chapter 2](#).

D. Allen, “The Log Periodic Loop Array (LPLA) Antenna,” *Antenna Compendium Vol 3*, pp 115-117

C. A. Balanis, *Antenna Theory, Analysis and Design*, 2nd Ed. (New York: John Wiley & Sons, 1997) Chapter 9.

P. C. Butson and G. T. Thompson, “A Note on the Calculation of the Gain of Log-Periodic Dipole Antennas,” *IEEE Trans on Antennas and Propagation*, Vol AP-24, No. 1, Jan 1976, pp 105-106.

- R. L. Carrel, "The Design of Log-Periodic Dipole Antennas," *1961 IRE International Convention Record*.
- L. B. Cebik, "The Monoband Log-Cell Yagi Revisited," (4-part series) *National Contest Journal*, Jan - Jul 2000.
- L. B. Cebik, "Some Preliminary Notes on Standard Design LPDAs for 3-30 MHz," (2-part series), *QEX*, Mar - May 2000.
- R. H. DuHamel and D. E. Isbell, "Broadband Logarithmically Periodic Antenna Structures," *1957 IRE National Convention Record*, Part 1.
- A. Eckols, "The Telerana: A Broadband 13- to 30-MHz Directional Antenna," *QST*, Jul 1981, pp 24-27.
- J. Fisher, "Development of the W8JF Waveram: A Planar Log-Periodic Quad Array," *Antenna Compendium Vol 1*, pp 50-54.
- M. Hansen, "The Improved Telerana, with Bonus 30/40 meter Coverage," *Antenna Compendium Vol 4*, pp 112-117.
- K. Heitner, "A Wide-Band, Low-Z Antenna—New Thoughts on Small Antennas," *Antenna Compendium Vol 1*, pp 48-49.
- D. E. Isbell, "Log-Periodic Dipole Arrays," *IRE Transactions on Antennas and Propagation*, Vol. AP-8, No. 3, May 1960.
- J. D. Kraus, *Antennas*, 2nd Ed. (New York: McGraw-Hill, 1988), Chapter 15.
- R. A. Johnson, ed., *Antenna Engineering Handbook*, 3rd Ed. (New York: McGraw-Hill, 1993), Chapters 14 and 26.
- K. Luetzelschwab, "Log Periodic Dipole Array Improvements," *The ARRL Antenna Compendium Vol 6*, pp 74-76.
- D. A. Mack, "A Second-Generation Spiderweb Antenna," *The ARRL Antenna Compendium Vol 1*, pp 55-59.
- P. E. Mayes and R. L. Carrel, "Log Periodic Resonant-V Arrays," *IRE Wescon Convention Record*, Part 1, 1961.
- P. E. Mayes, G. A. Deschamps, and W. T. Patton, "Backward Wave Radiation from Periodic Structures and Application to the Design of Frequency Independent Antennas," *Proc. IRE*.
- J. J. Meyer, "A Simple Log-Yag Array for 50 MHz," *Antenna Compendium Vol 1*, pp 62-63.
- C. T. Milner, "Log Periodic Antennas," *QST*, Nov 1959, pp 11-14.
- W. I. Orr and S. D. Cowan, *Beam Antenna Handbook*, pp 251-253.
- P. D. Rhodes, "The Log-Periodic Dipole Array," *QST*, Nov 1973, pp 16-22.
- P. D. Rhodes and J. R. Painter, "The Log-Yag Array," *QST*, Dec 1976, pp 18-21.
- P. D. Rhodes, "The Log-Periodic V Array," *QST*, Oct 1979, pp 40-43.
- P. D. Rhodes, "The K4EWG Log Periodic Array," *Antenna Compendium Vol 3*, pp 118-123
- V. H. Rumsey, *Frequency Independent Antennas* (New York: Academic Press, 1966).
- F. Scholz, "A 14-30 MHz LPDA for Limited Space," *Antenna Compendium Vol 2*, pp 96-99
- W. L. Stutzman and G. A. Thiele, *Antenna Theory and Design*, 2nd Ed. (New York: John Wiley & Sons, 1998), Chapter 6.
- J. J. Uhl, "Construct a Wire Log-Periodic Dipole Array for 80 or 40 Meters," *QST*, Aug 1976, pp 21-24.
- R. F. Zimmer, "Three Experimental Antennas for 15 Meters," *CQ*, Jan 1983, pp 44-45.
- R. F. Zimmer, "Development and Construction of 'V' Beam Antennas," *CQ*, Aug 1983, pp 28-32.

# Chapter 11

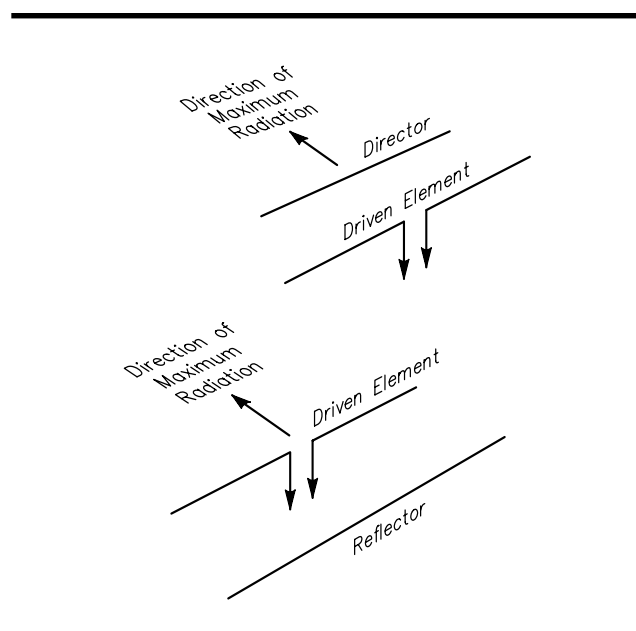
# HF Yagi Arrays

Along with the dipole and the quarter-wave vertical, radio amateurs throughout the world make extensive use of the Yagi array. The Yagi was invented in the 1920s by Hidetsugu Yagi and Shintaro Uda, two Japanese university professors. Uda did much of the developmental work, while Yagi introduced the array to the world outside Japan through his writings in English. Although the antenna should properly be called a *Yagi-Uda* array, it is commonly referred to simply as a *Yagi*.

The Yagi is a type of endfire multielement array. At the minimum, it consists of a single driven element and a single parasitic element. These elements are placed parallel to each other, on a supporting boom spacing them apart. This arrangement is known as a 2-element Yagi. The parasitic element is termed a *reflector* when it is placed behind the driven element, opposite to the direction of maximum radiation, and is called a *director* when it is placed ahead of the driven element. See **Fig 1**. In the VHF and UHF spectrum, Yagis employing 30 or more elements are not uncommon, with a single reflector and multiple directors. See [Chapter 18](#) for details on VHF and UHF Yagis. Large HF arrays may employ 10 or more elements, and will be covered in this chapter.

The gain and directional pattern of a Yagi array is determined by the relative amplitudes and phases of the currents induced into all the parasitic elements. Unlike the directly driven multielement arrays considered in [Chapter 8](#), where the designer must compensate for mutual coupling between elements, proper Yagi operation *relies on* mutual coupling. The current in each parasitic element is determined by its spacing from both the driven element and other parasitic elements, and by the tuning of the element itself. Both length and diameter affect element tuning.

For about 50 years amateurs and professionals created Yagi array designs largely by “cut and try” experimental techniques. In the early 1980s, Jim Lawson, W2PV, described in detail for the amateur audience the fundamental mathematics involved in modeling Yagis. His book *Yagi Antenna Design* is highly recommended for serious antenna designers. The advent of powerful microcomputers and



**Fig 1—Two-element Yagi systems using a single parasitic element. At A the parasitic element acts as a director, and at B as a reflector. The arrows show the direction in which maximum radiation takes place.**

sophisticated computer antenna modeling software in the mid 1980s revolutionized the field of Yagi design for the radio amateur. In a matter of minutes, a computer can try 100,000 or more different combinations of element lengths and spacings to create a Yagi design tailored to meet a particular set of high-performance parameters. To explore this number of combinations experimentally, a human experimenter would take an unimaginable amount of time and dedication, and the process would no doubt suffer from considerable measurement errors. With the computer tools available today, an antenna can be designed, constructed and then put up in the air, with little or no tuning or pruning required.

# Yagi Performance Parameters

There are three main parameters used to characterize the performance of a particular Yagi—*forward gain*, *pattern* and *drive impedance/SWR*. Another important consideration is *mechanical strength*. It is very important to recognize that each of the three electrical parameters should be characterized over the frequency band of interest in order to be meaningful. Neither the gain, SWR or pattern measured at a single frequency gives very much insight into the overall performance of a particular Yagi. Poor designs have been known to reverse their directionality over a frequency band, while other designs have excessively narrow SWR bandwidths, or overly “peaky” gain response.

Finally, an antenna’s ability to survive the wind and ice conditions expected in one’s geographical location is an important consideration in any design. Much of this chapter will be devoted to describing detailed Yagi designs which are optimized for a good balance between gain, pattern and SWR over various amateur bands, and which are designed to survive strong winds and icing.

## YAGI GAIN

Like any other antenna, the gain of a Yagi must be stated in comparison to some standard of reference. Designers of phased vertical arrays often state gain referenced to a single, isolated vertical element. See the section on “[Phased Array Techniques](#)” in Chapter 8.

Many antenna designers prefer to compare gain to that of an *isotropic radiator in free space*. This is a theoretical antenna that radiates equally well in all directions, and by definition, it has a gain of 0 *dBi* (dB isotropic). Many radio amateurs, however, are comfortable using a dipole as a standard reference antenna, mainly because it is *not* a theoretical antenna.

In free space, a dipole does not radiate equally well in all directions—it has a “figure-eight” azimuth pattern, with deep nulls off the ends of the wire. In its favored directions, a free-space dipole has 2.15 dB gain compared to the isotropic radiator. You may see the term *dBd* in amateur literature, meaning gain referenced to a dipole in free space. Subtract 2.15 dB from gain in *dBi* to convert to gain in *dBd*.

Assume for a moment that we take a dipole out of “free space,” and place it one wavelength over the ocean, whose salt-water makes an almost perfect ground. At an elevation angle of 15°, where seawater-reflected radiation adds in phase with direct radiation, the dipole has a gain of about 6 dB, compared to its gain when it was in free space, isolated from any reflections. See Chapter 3, “[The Effects of Ground](#).”

It is perfectly legitimate to say that this dipole has a gain of 6 *dBd*, although the term “*dBd*” (meaning “dB dipole”) makes it sound as though the dipole somehow has gain over itself! Always remember that gain expressed in *dBd* (or *dBi*) refers to the *counterpart antenna in free space*. The gain of the dipole over saltwater in this example can be rated at either 6 *dBd* (over a dipole in free space), or as

8.15 *dBi* (over an isotropic radiator in free space). Each frame of reference is valid, as long as it is used consistently and clearly. In this chapter we will often switch between Yagis in free space and Yagis over ground. To prevent any confusion, gains will be stated in *dBi*.

Yagi free-space gain ranges from about 5 *dBi* for a small 2-element design to about 20 *dBi* for a 31-element long-boom UHF design. The length of the boom is the main factor determining the gain a Yagi can deliver. Gain as a function of boom length will be discussed in detail after the sections below defining antenna response patterns and SWR characteristics.

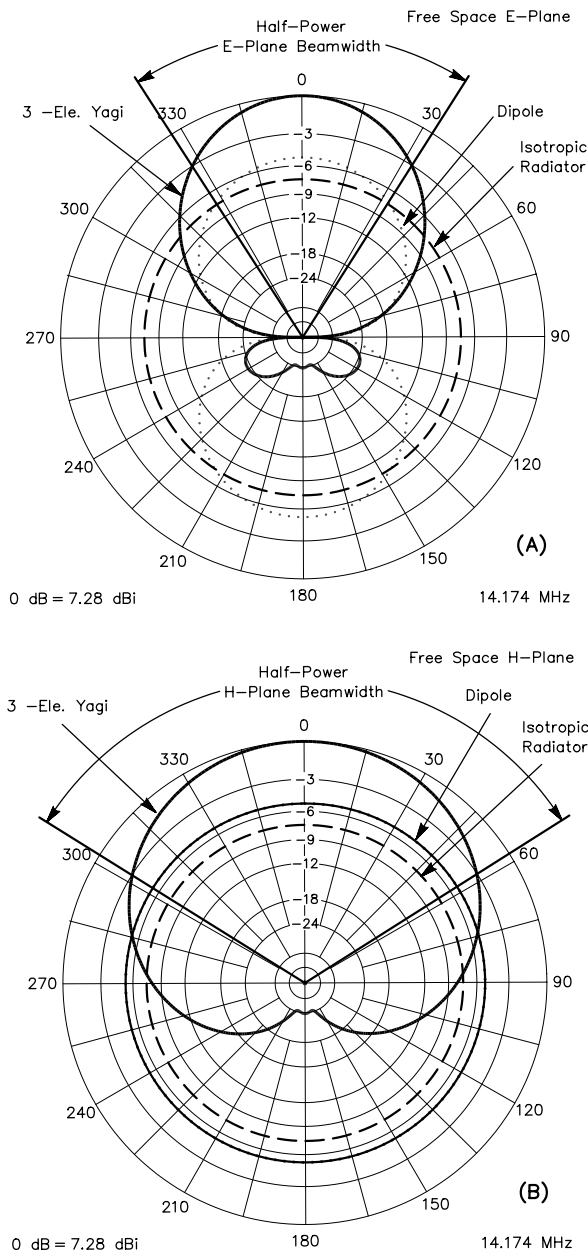
## RESPONSE PATTERNS— FRONT-TO-REAR RATIO

As discussed in [Chapter 2](#), for an antenna to have gain, it must concentrate energy radiated in a particular direction, at the expense of energy radiated in other directions. Gain is thus closely related to an antenna’s directivity pattern, and also to the losses in the antenna. [Fig 2](#) shows the *E-plane* (also called *E-field*, for electric field) and *H-plane* (also called *H-field*, for magnetic field) pattern of a 3-element Yagi in free space, compared to a dipole, and an isotropic radiator. These patterns were generated using the computer program *NEC*, which is highly regarded by antenna professionals for its accuracy and flexibility.

In free space there is no earth reference to determine whether the antenna polarization is horizontal or vertical, and so its response patterns are labeled as E-field (electric) or H-field (magnetic). For a Yagi mounted over ground rather than in free space, if the E-field is parallel to the earth (that is, the elements are parallel to the earth) then the antenna polarization is horizontal, and its E-field response is then usually referred to as its *azimuth* pattern. Its H-field response is then referred to as its *elevation* pattern.

[Fig 2A](#) demonstrates how this 3-element Yagi in free space exhibits 7.28 *dBi* of gain (referenced to isotropic), and has 5.13 *dB* gain over a free-space dipole. The gain is in the forward direction on the graph at 0° azimuth, and the forward part of the lobe is called the *main lobe*. For this particular antenna, the angular width of the E-plane main lobe at the half power, or 3 *dB* points compared to the peak, is about 66°. This performance characteristic is called the antenna’s azimuthal *half-power beamwidth*.

Again as seen in [Fig 2A](#), this antenna’s response in the reverse direction at 180° azimuth is 34 *dB* less than in the forward direction. This characteristic is called the antenna’s *front-to-back ratio*, and it describes the ability of an antenna to discriminate, for example, against interfering signals coming directly from the rear, when the antenna is being used for reception. In [Fig 2A](#) there are two sidelobes, at 120° and at 240° azimuth, which are about 24 *dB* down from the peak response at 0°. Since interference can come from any direction, not only directly off the back of an antenna,



**Fig 2—E-plane (electric field) and H-plane (magnetic field) response patterns for 3-element 20-meter Yagi in free space. At A the E-plane pattern for a typical 3-element Yagi is compared with a dipole and an isotropic radiator. At B the H-plane patterns are compared for the same antennas. The Yagi has an E-plane half-power beamwidth of 66°, and an H-plane half-power beamwidth of about 120°. The Yagi has 7.28 dBi (5.13 dBd) of gain. The front-to-back ratio, which compares the response at 0° and at 180°, is about 35 dB for this Yagi. The front-to-rear ratio, which compares the response at 0° to the largest lobe in the rearward 180° arc behind the antenna, is 24 dB, due to the lobes at 120° and 240°.**

these kinds of sidelobes limit the ability to discriminate against rearward signals. The term *worst-case front-to-rear ratio* is used to describe the worst-case rearward lobe in the 180°-wide sector behind the antenna's main lobe. In this case, the worst-case front-to-rear ratio is 24 dB.

In the rest of this chapter the worst-case front-to-rear ratio will be used as a performance parameter, and will be abbreviated as "F/R." For a dipole or an isotropic radiator, Fig 2A demonstrates that F/R is 0 dB. Fig 2B depicts the H-field response for the same 3-element Yagi in free space, again compared to a dipole and an isotropic radiator in free space. Unlike the E-field pattern, the H-field pattern for a Yagi does not have a null at 90°, directly over the top of the Yagi. For this 3-element design, the H-field half-power beamwidth is approximately 120°.

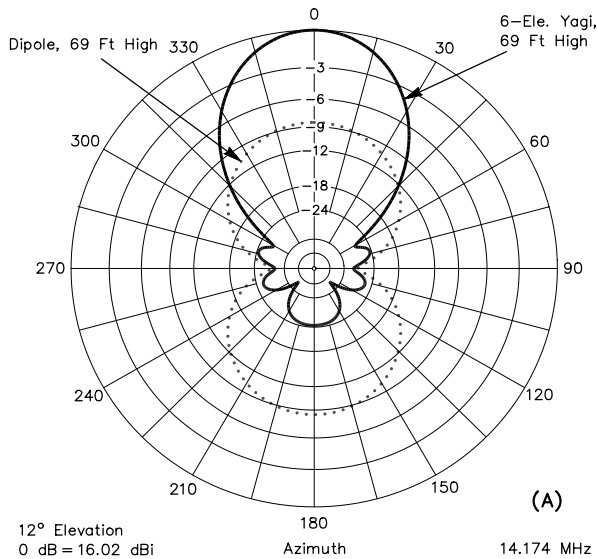
**Fig 3** compares the azimuth and elevation patterns for a horizontally polarized 6-element 14-MHz Yagi, with a 60-foot boom mounted one wavelength over ground, to a dipole at the same height. As with any horizontally polarized antenna, the height above ground is the main factor determining the peaks and nulls in the elevation pattern of each antenna. Fig 3A shows the E-field pattern, which has now been labeled as the Azimuth pattern. This antenna has a half-power azimuthal beamwidth of about 50°, and at an elevation angle of 12° it exhibits a forward gain of 16.02 dBi, including about 5 dB of ground reflection gain over relatively poor ground, with a dielectric constant of 13 and conductivity of 5 mS/m. In free space this Yagi has a gain of 10.97 dBi.

The H-field elevation response of the 6-element Yagi has a half-power beamwidth of about 60° in free space, but as shown in **Fig 3B**, the first lobe (centered at 12° in elevation) has a half-power beamwidth of only 13° when the antenna is mounted one wavelength over ground. The dipole at the same height has a very slightly larger first-lobe half-power elevation beamwidth of 14°, since its free-space H-field response is omnidirectional. Note that the free-space H-field directivity of the Yagi suppresses its second lobe over ground (at an elevation angle of about 40°) to 8 dBi, while the dipole's response at its second lobe peak (at about 48°) is at a level of 9 dBi.

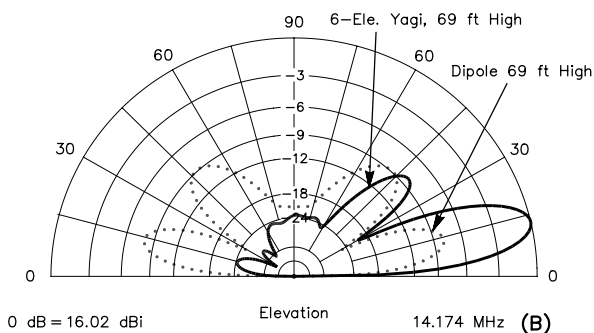
The shape of the azimuthal pattern for a Yagi operated over real ground will change slightly as the Yagi is placed closer and closer to earth. Generally, however, the azimuth pattern doesn't depart significantly from the free-space pattern until the antenna is less than 0.5 λ high. This is just over 17 feet high at 28.4 MHz, and just under 35 feet at 14.2 MHz, heights that are not difficult to achieve for most amateurs. Some advanced computer programs can optimize Yagis at the exact installation height.

### DRIVE IMPEDANCE AND SWR

The impedance at the driven element in a Yagi is affected not only by the tuning of the driven element itself, but also by the spacing and tuning of nearby parasitic elements, and to a lesser extent by the presence of ground. In some designs which have been tuned solely for maximum

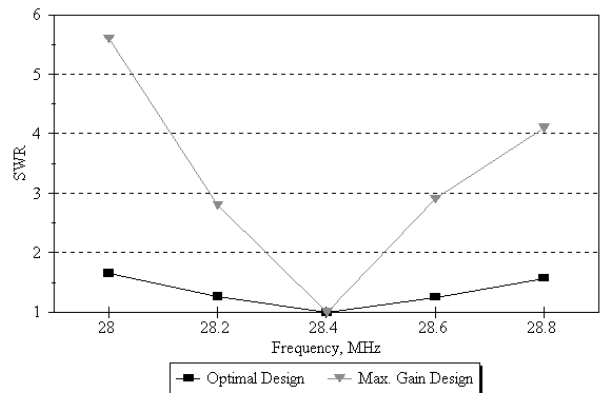


12° Elevation  
0 dB = 16.02 dBi  
Azimuth  
14.174 MHz



0 dB = 16.02 dBi  
Elevation  
14.174 MHz (B)

**Fig 3—Azimuth pattern for 6-element 20-meter Yagi on 60-foot long boom, mounted 69 feet over ground. At A, the azimuth pattern at 12° elevation angle is shown, compared to a dipole at the same height. Peak gain of the Yagi is 16.04 dBi, or just over 8 dB compared to the dipole. At B, the elevation pattern for the same two antennas is shown. Note that the peak elevation pattern of the Yagi is compressed slightly lower compared to the dipole, even though they are both at the same height over ground. This is most noticeable for the Yagi's second lobe, which peaks at about 40°, while the dipole's second lobe peaks at about 48°. This is due to the greater free-space directionality of the Yagi at higher angles.**



**Fig 4—SWR over the 28.0 to 28.8-MHz portion of the 10-meter band for two different 3-element Yagi designs. One is designed strictly for maximum gain, while the second is optimized for F/R pattern and SWR over the frequency band. A Yagi designed only for maximum gain usually suffers from a very narrow SWR bandwidth.**

gain, the driven-element impedance can fall to very low levels, sometimes less than 5 Ω. This can lead to excessive losses due to conductor resistance, especially at VHF and UHF. In a Yagi that has been optimized solely for gain, conductor losses are usually compounded by large excursions in impedance levels with relatively small changes in frequency. The SWR can thus change dramatically over a band and can create additional losses in the feed cable. **Fig 4** illustrates the SWR over the 28 to 28.8 MHz portion of the 10-meter amateur band for a 5-element Yagi on a 24-foot boom, which has been tuned for maximum forward gain at a spot frequency of 28.4 MHz. Its SWR curve is contrasted to that of a Yagi designed for a good compromise of gain, SWR and F/R.

Even professional antenna designers have difficulty accurately measuring forward gain. On the other hand, SWR can easily be measured by professional and amateur alike. Few manufacturers would probably want to advertise an antenna with the narrow-band SWR curve shown in Fig 4!

## Yagi Performance Optimization

### DESIGN GOALS

The previous section discussing driven-element impedance and SWR hinted at possible design trade-offs among gain, pattern and SWR, especially when each parameter is considered over a frequency band rather than at a spot frequency. Trade-offs in Yagi design parameters can be a matter of personal taste and operating style. For example, one operator might exclusively operate the CW

portions of the HF bands, while another might only be interested in the Phone portions. Another operator may want a good pattern in order to discriminate against signals coming from a particular direction; someone else may want the most forward gain possible, and may not care about responses in other directions.

Extensive computer modeling of Yagis indicates that the parameter that must be compromised most to achieve



wide bandwidths for front-to-rear ratio and SWR is forward gain. However, not much gain must be sacrificed for good F/R and SWR coverage, especially on long-boom Yagis.

Although 10- and 7-MHz Yagis are not rare, the HF bands from 14 to 30 MHz are where Yagis are most often found, mainly due to the mechanical difficulties involved with making sturdy antennas for lower frequencies. The highest HF band, 28.0 to 29.7 MHz, represents the largest percentage bandwidth of the upper HF bands, at almost 6%. It is difficult to try to optimize in one design the main performance parameters of gain, worst-case F/R ratio and SWR over this large a band. Many commercial designs thus split up their 10-meter designs into antennas covering one of two bands: 28.0 to 28.8 MHz, and 28.8 to 29.7 MHz. For the amateur bands below 10 meters, optimal designs that cover the entire band are more easily achieved.

### DESIGN VARIABLES

There are only a few variables available when one

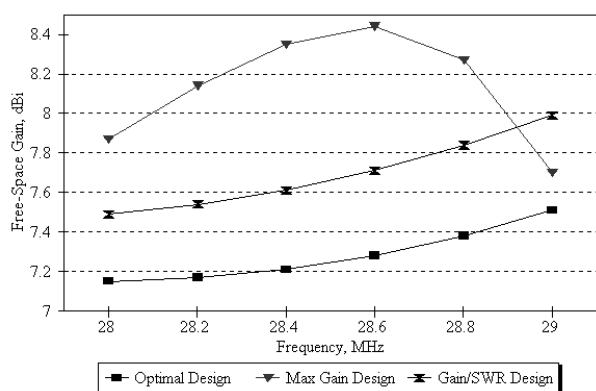
is designing a Yagi to meet certain design goals. The variables are:

1. The physical length of the boom
2. The number of elements on the boom
3. The spacing of each element along the boom
4. The tuning of each element
5. The type of matching network used to feed the array.

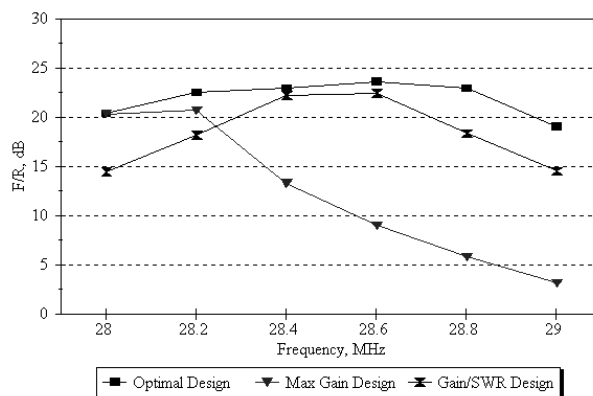
### GAIN AND BOOM LENGTH

As pointed out earlier, the gain of a Yagi is largely a function of the length of the boom. As the boom is made longer, the maximum gain potential rises. For a given boom length, the number of elements populating that boom can be varied, while still maintaining the antenna's gain, provided of course that the elements are tuned properly. In general, putting more elements on a boom gives the designer added flexibility to achieve desired design goals, especially to spread the response out over a frequency band.

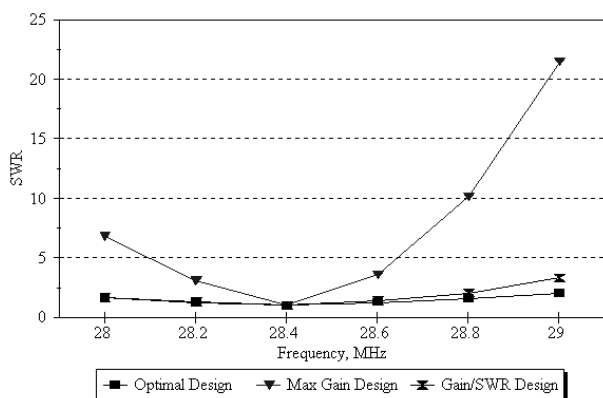
Fig 5A is an example illustrating gain versus frequency



(A)



(B)



(C)

Fig 5—Comparisons of three different 3-element 10-meter Yagi designs using 8-foot booms. At A, gain comparisons are shown. The Yagi designed for the best compromise of gain and SWR sacrifices an average of about 0.5 dB compared to the antenna designed for maximum gain. The Yagi designed for optimal F/R, gain and SWR sacrifices an average of 1.0 dB compared to the maximum-gain case, and about 0.4 dB compared to the compromise gain and SWR case. At B, the front-to-rear ratio is shown for the three different designs. The antenna designed for optimal combination of gain, F/R and SWR maintains a F/R higher than 20 dB across the entire frequency range, while the antenna designed strictly for gain has a F/R of 3 dB at the high end of the band. At C, the three antenna designs are compared for SWR bandwidth. At the high end of the band, the antenna designed strictly for gain has a very high SWR.

for three different types of 3-element Yagis on 8-foot booms. The three antennas were designed for the lower end of the 10-meter band, 28.0 to 28.8 MHz, based on the following different design goals:

- Antenna 1: Maximum mid-band gain, regardless of F/R or SWR across the band
- Antenna 2: SWR less than 2:1 over the frequency band; best compromise gain, with no special consideration for F/R over the band.
- Antenna 3: “Optimal” case: F/R greater than 20 dB, SWR less than 2:1 over the frequency band; best compromise gain.

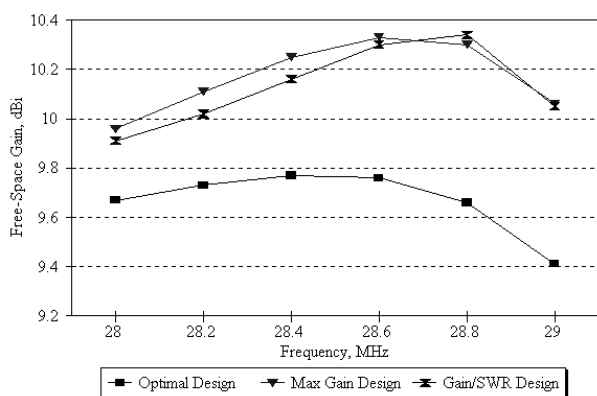
Fig 5B shows the F/R over the frequency band for these three designs, and Fig 5C shows the SWR curves over the frequency band. Antenna 1, the design which strives strictly for maximum gain, has a poor SWR response over the band, as might be expected after the previous section discussing SWR. The SWR is 10:1 at 28.8 MHz and rises to 22:1 at 29 MHz. At 28 MHz, at the low end of the band, the SWR of the maximum-gain design is more than 6:1. Clearly, designing for maximum gain alone produces an unacceptable design in terms of SWR bandwidth. The F/R for Antenna 1 reaches a

high point of about 20 dB at the low-frequency end of the band, but falls to only 3 dB at the high-frequency end.

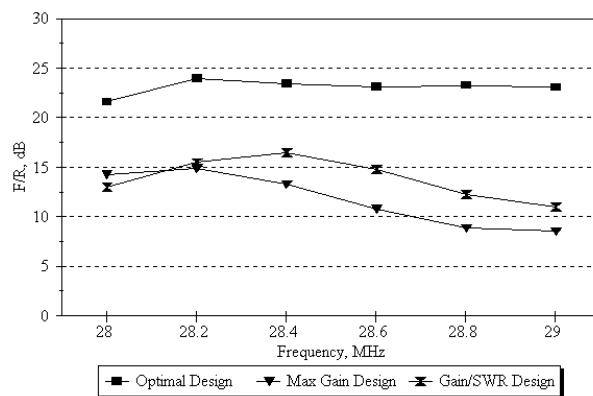
Antenna 2, designed for the best compromise of gain while the SWR across the band is held to less than 2:1, achieves this goal, but at an average gain sacrifice of 0.7 dB compared to the maximum gain case. The F/R for this design is just under 15 dB over the band. This design is fairly typical of many amateur Yagi designs before the advent of computer modeling and optimization programs. SWR can easily be measured, and experimental optimization for forward gain is a fairly straightforward procedure. By contrast, overall pattern optimization is not a trivial thing to achieve experimentally, particularly for antennas with more than four or five elements.

Antenna 3, designed for an optimum combination of F/R, SWR and gain, compromises forward gain an average of 1.0 dB compared to the maximum gain case, and about 0.4 dB compared to the compromise gain/SWR case. It achieves its design objectives of more than 20 dB F/R over the 28.0 to 28.8 MHz portion of the band, with an SWR less than 2:1 over that range.

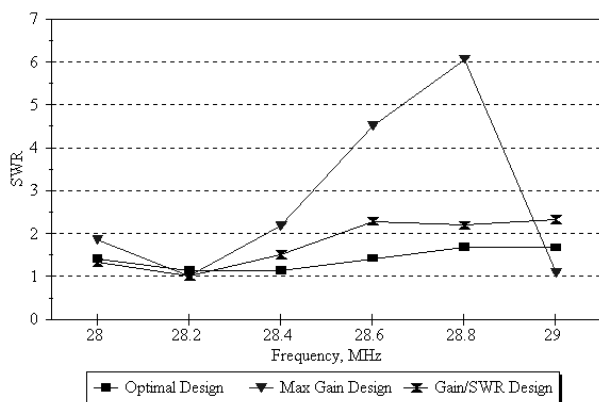
Fig 6A shows the free-space gain versus frequency for the same three types of designs, but for a bigger 5-element 10-meter Yagi on a 20-foot boom. Fig 6B shows the variation



(A)



(B)



(C)

**Fig 6—Comparisons of three different designs for 5-element 10-meter Yagis on 20-foot booms. At A, the gain of three different 5-element 10-meter Yagi designs are graphed. The difference in gain between the three antennas narrows because the elements can be stagger-tuned to spread the response out better over the desired frequency band. The average gain reduction for the fully optimized antenna design is about 0.5 dB. At B, the optimal antenna displays better than 22 dB F/R over the band, while the Yagi designed for gain and SWR displays on average 10 dB less F/R throughout the band. At C, the SWR bandwidth is compared for the three Yagis. The antenna designed strictly for forward gain has a poor SWR bandwidth and a high peak SWR of 6:1 at 28.8 MHz.**

in F/R, and Fig 6C shows the SWR curves versus frequency. Once again, the design which concentrates solely on maximum gain has a poor SWR curve over the band, reaching just over 6:1 toward the high end of the band. The difference in gain between the maximum gain case and the optimum design case has narrowed for this size of boom to an average of under 0.5 dB. This comes about because the designer has access to more variables in a 5-element design than he does in a 3-element design, and he can stagger-tune the various elements to spread the response out over the whole band.

Fig 7A, B and C show the same three types of designs, but for a 6-element Yagi on a 36-foot boom. The SWR bandwidth of the antenna designed for maximum gain has improved compared to the previous two shorter-boom examples, but the SWR still rises to more than 4:1 at 28.8 MHz, while the F/R ratio is pretty constant over the band, at a mediocre 11 dB average level. While the antenna designed for gain and SWR does hold the SWR below 2:1 over the band, it also has the same mediocre level of F/R performance as does the maximum-gain design.

The optimized 36-foot boom antenna achieves an

excellent F/R of more than 22 dB over the whole 28.0 to 28.8 MHz band. Again, the availability of more elements and more space on the 36-foot long boom gives the designer more flexibility in broadbanding the response over the whole band, while sacrificing only 0.3 dB of gain compared to the maximum-gain design.

Fig 8A, B, and C show the same three types of 10-meter designs, but now for a 60-foot boom, populated with eight elements. With eight elements and a very long boom on which to space them out, the antenna designed solely for maximum gain can achieve a much better SWR response across the band, although the SWR does rise to more than 7:1 at the very high end of the band. The SWR remains less than 2:1 from 28.0 to 28.7 MHz, much better than for shorter-boom designs. The worst-case F/R ratio is never better than 19 dB, however, and remains around 10 dB over much of the band. The antenna designed for the best compromise gain and SWR loses only about 0.1 dB of gain compared to the maximum-gain design, but does little better in terms of F/R across the band.

Contrasted to these two designs, the antenna optimized for F/R, SWR and gain has an outstanding pattern, exhibiting

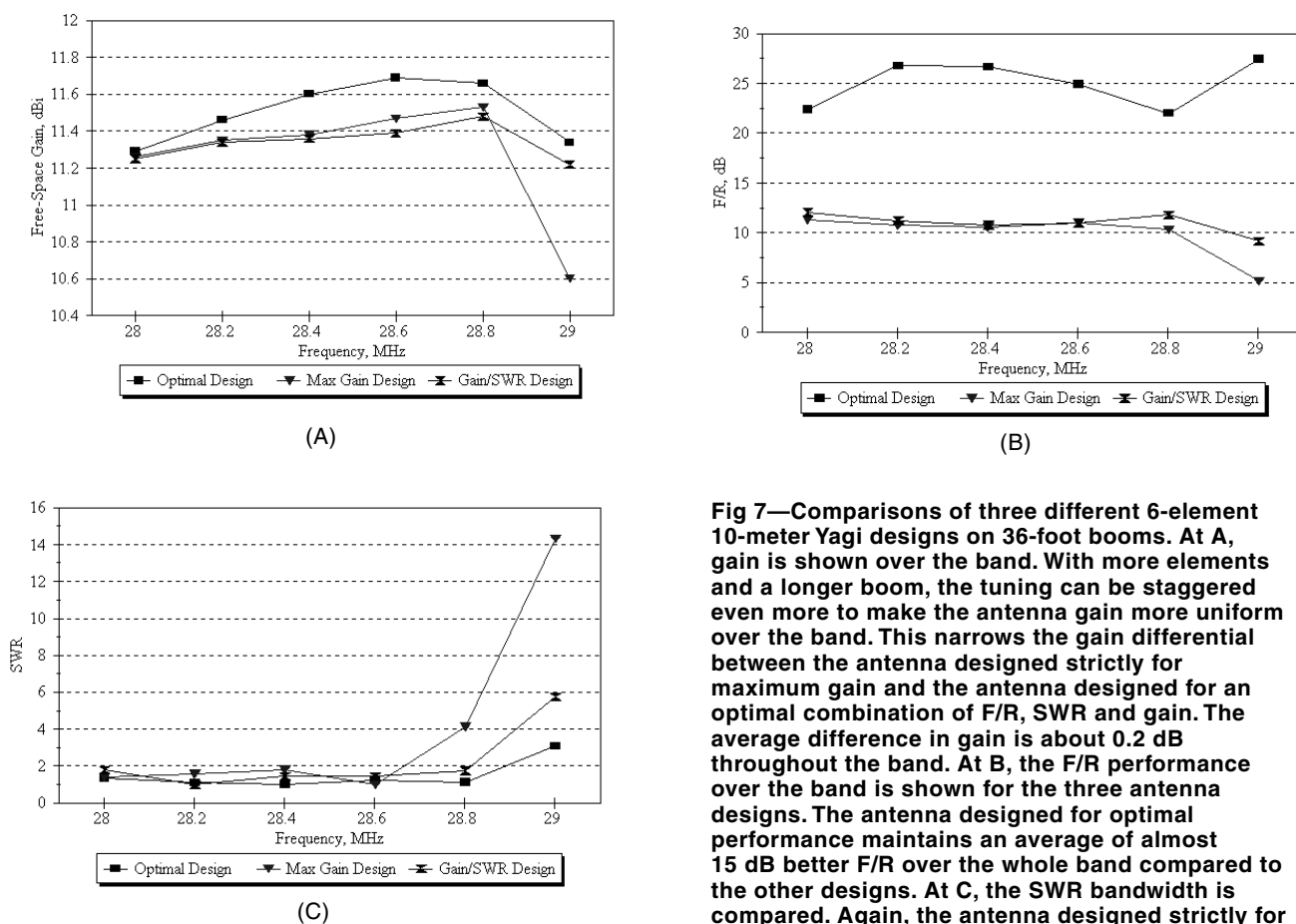
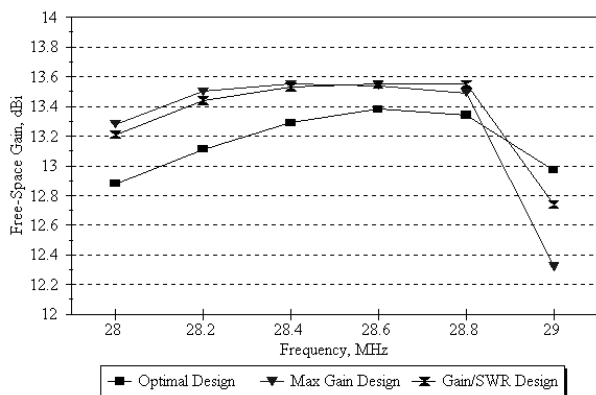
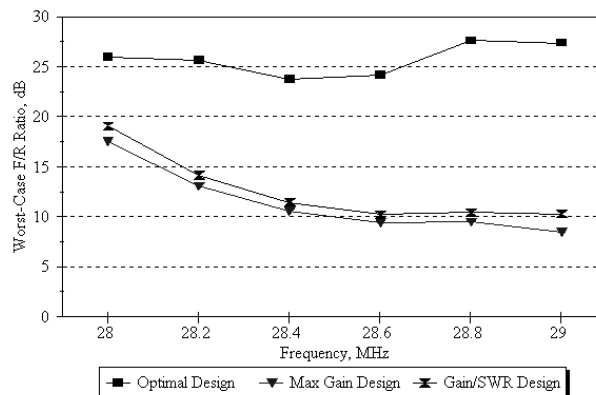


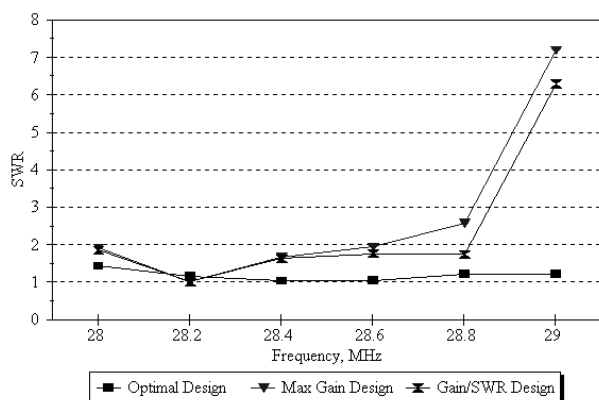
Fig 7—Comparisons of three different 6-element 10-meter Yagi designs on 36-foot booms. At A, gain is shown over the band. With more elements and a longer boom, the tuning can be staggered even more to make the antenna gain more uniform over the band. This narrows the gain differential between the antenna designed strictly for maximum gain and the antenna designed for an optimal combination of F/R, SWR and gain. The average difference in gain is about 0.2 dB throughout the band. At B, the F/R performance over the band is shown for the three antenna designs. The antenna designed for optimal performance maintains an average of almost 15 dB better F/R over the whole band compared to the other designs. At C, the SWR bandwidth is compared. Again, the antenna designed strictly for maximum gain exhibits a high SWR of 4:1 at 28.8 MHz, and rises to more than 14:1 at 29.0 MHz.



(A)



(B)



(C)

**Fig 8—Comparisons of three different 8-element 10-meter Yagi designs using 60-foot booms. At A, gain is shown over the frequency band. With even more freedom to stagger-tune elements and a very long boom on which to place them, the average antenna gain differential over the band is now less than 0.3 dB between the three design cases. At B, an excellent 24 dB F/R for the optimal design is maintained over the whole band, compared to the average of about 12 dB for the other two designs. At C, the SWR differential over the band is narrowed between the three designs, again because there are more variables available to broaden the bandwidth.**

an F/R of more than 24 dB across the entire band, while keeping the SWR below 2:1 from 28.0 to 28.9 MHz. It must sacrifice an average of only 0.4 dB compared to the maximum gain design at the low end of the band, and actually has more gain than the maximum gain and gain/SWR designs at the high-frequency end of the band.

The conclusion drawn from these and many other detailed comparisons is that designing strictly for maximum mid-band gain yields an inferior design when the antenna is examined over an entire frequency band, especially in terms of SWR. Designing a Yagi for both gain and SWR will yield antennas which have mediocre rearward patterns, but which lose relatively little gain compared to the maximum gain case, at least for designs with more than three elements.

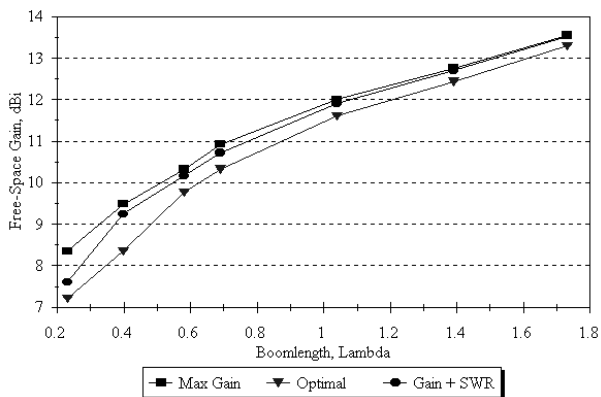
However, designing a Yagi for an optimal combination of F/R, SWR and gain results in a loss of gain less than 0.5 dB compared to designs designed only for gain and SWR. Fig 9 summarizes the forward gain achieved for the three different design types versus boom length, as expressed in wavelength. Unless otherwise stated, the Yagis described in the rest of this chapter have the following design goals over a desired frequency band:

1. Front-to-rear ratio over the frequency band of more than 20 dB
2. SWR over the frequency band less than 2:1
3. Maximum gain consistent with points 1 and 2 above

Just for fun, Fig 10 shows the gain versus boom length for theoretical 20-meter Yagis that have been designed to meet the three design goals above. The 31-element design for 14 MHz would be wondrous to behold. Sadly, it is unlikely that anyone will build one, considering that the boom would be 724 feet long! However, such a design *does* become practical when scaled to 432 MHz. In fact, a K1FO 22-element and a K1FO 31-element Yagi are the prototypes for the theoretical 14-MHz long-boom designs. See Chapter 18 for VHF and UHF Yagis.

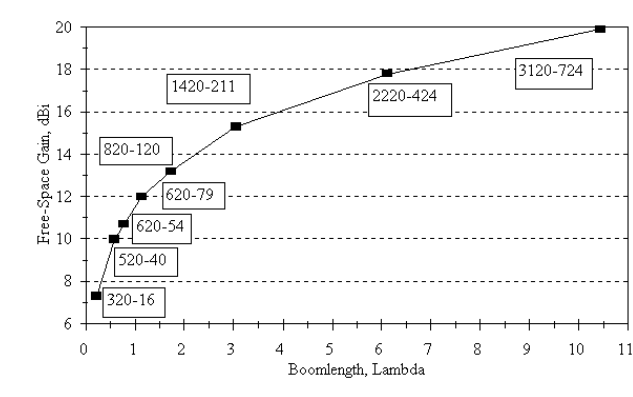
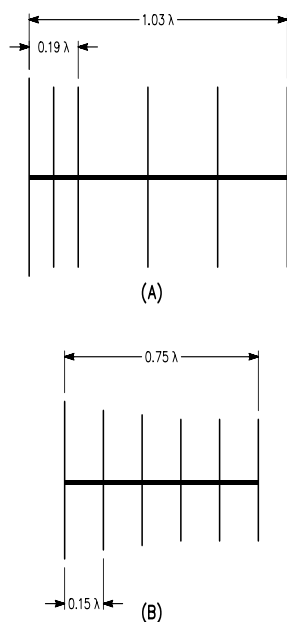
## OPTIMUM DESIGNS AND ELEMENT SPACING

One of the more interesting results of computer modeling and optimization of high-performance Yagis with four or more elements is that a distinct pattern in the element spacings along the boom shows up consistently. This



**Fig 9—Gain versus boom length for three different 10-meter design goals. The goals are: (1) designed for maximum gain across band, (2) designed for a compromise of gain and SWR, and (3) designed for optimal F/R, SWR and gain across 28.0 to 28.8 MHz portion of 10-meter band. The gain difference is less than 0.5 dB for booms longer than approximately  $0.5 \lambda$ .**

pattern is relatively independent of boom length, once the boom is longer than about  $0.3 \lambda$ . The reflector, driven element and first director of these optimal designs are typically bunched rather closely together, occupying together only about  $0.15$  to  $0.20 \lambda$  of the boom. This pattern contrasts sharply with older designs, where the amount of boom taken up by the reflector, driven element and first director was typically more than  $0.3 \lambda$ . **Fig 11** shows the element spacings for an optimized 6-element, 36-foot boom, 10-meter design,



**Fig 10—Theoretical gain versus boom length for 20-meter Yagis designed for optimal combination of F/R, SWR and gain across the entire 14.0 to 14.35 MHz band. The theoretical gain approaches 20 dBi for a gigantic 724-foot boom, populated with 31 elements. Such a design on 20 meters is not too practical, of course, but can readily be achieved on a 24-foot boom on 432 MHz.**

compared to a W2PV 6-element design with constant spacing of  $0.15 \lambda$  between all elements.

A problem arises with such a bunching of elements toward the reflector end of the boom—the wind loading of the antenna is not equal along the boom. Unless properly compensated, such new-generation Yagis will act like windvanes, punishing, and often breaking, the rotators trying to turn, or hold, them in the wind. One successful solution to windvaning has been to employ “dummy elements” made of PVC piping. These nonconducting elements are placed on the boom close to the last director so the windload is equalized at the mast-to-boom bracket. In addition, it may be necessary to insert a small amount of lead weight at one end of the boom in order to balance the antenna weight.

Despite the relatively close spacing of the reflector, driven element and first director, modern optimal Yagi designs are not overly sensitive to small changes in either element length or spacing. In fact, these antennas can be constructed from design tables without excessive concern about close dimensional tolerances. In the HF range up to 30 MHz, building the antennas to the nearest  $1/8$  inch results in performance remarkably consistent with the computations, without any “tweaking” or fine-tuning when the Yagi is on the tower.

**Fig 11—Tapered spacing versus constant element spacing. At A, illustration of how the spacing of the reflector, driven element and first director (over the first  $0.19 \lambda$  of the boom) of an optimally designed Yagi is bunched together compared to the Yagi at B, which uses constant  $0.15 \lambda$  spacing between all elements. The optimally designed antenna has more than 22 dB F/R and an SWR less than 1.5:1 over the frequency band from 28.0 to 28.8 MHz.**

## ELEMENT TUNING

Element tuning (or *self-impedance*) is a complex function of the effective electrical length of each element and the effective diameter of the element. In turn, the effective length and diameter of each element is related to the taper schedule (if telescoping aluminum tubing is used, the most common method of construction), the length of each telescoping section, the type and size of mounting bracket used to secure the element to or through the boom, and the size of the Yagi boom itself. See the section entitled “Antenna Frequency Scaling,” and “Tapered Elements” in Chapter 2 of this book for details about element tuning as a function of tapering and element diameter. Note especially that Yagis constructed using wire elements will perform very differently compared to the same antenna constructed with elements made of telescoping aluminum tubing.

The process by which a modern Yagi is designed

usually starts out with the selection of the longest boom possible for a given installation. A suitable number of elements of a given taper schedule are then placed on this boom, and the gain, pattern and SWR are calculated over the entire frequency band of interest to the operator. Once an electrical design is chosen, the designer must then ensure the mechanical integrity of the antenna design. This involves verifying the integrity of the boom and each element in the face of the wind and ice loading expected for a particular location. The section entitled “Construction with Aluminum Tubing” in Chapter 20 of this book shows details of tapered telescoping aluminum elements for the upper HF bands. In addition, the ARRL book *Physical Design of Yagi Antennas*, by Dave Leeson, W6QHS, describes the mechanical design process for all portions of a Yagi antenna very thoroughly, and is highly recommended for serious Yagi builders.

## Specific Yagi Designs

The detailed Yagi design tables which follow are for two taper schedules for Yagis covering the 14- through 30-MHz amateur bands. The heavy-duty elements are designed to survive at least 120-mph winds without icing, or 85-mph winds with  $\frac{1}{4}$ -inch radial ice. The medium-duty elements are designed to survive winds greater than 80 mph, or 60-mph winds with  $\frac{1}{4}$ -inch radial ice.

For 10.1 MHz, the elements shown are capable of surviving 105-mph winds, or 93-mph winds with  $\frac{1}{4}$ -inch radial ice. For 7.1 MHz the elements shown can survive 93-mph winds, or 69-mph winds with  $\frac{1}{4}$ -inch radial ice. For these two lower frequency bands, the elements and the booms needed are very large and heavy. Mounting, turning and keeping such antennas in the air is not a trivial task.

Each element is mounted above the boom with a heavy rectangular aluminum plate, by means of U-bolts with saddles, as shown in Fig 27 of Chapter 18, and as described in the ARRL book *Yagi Antenna Design*. This method of element mounting is rugged and stable, and because the element is mounted away from the boom, the amount of element detuning due to the presence of the boom is minimal. The element dimensions given in each table already take into account any element detuning due to the boom-to-element mounting plate. For each element, the tuning is determined by the length of the tip, since the inner tubes are fixed in diameter and length.

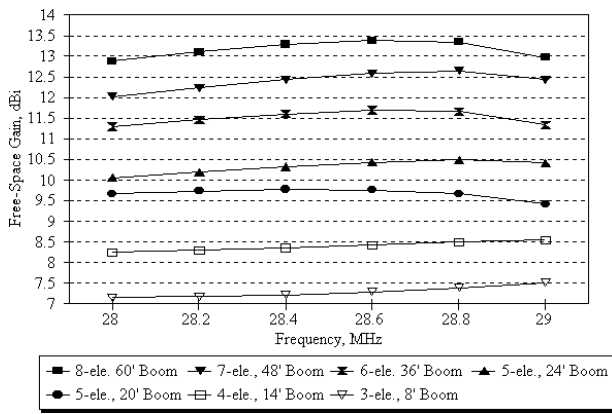
Note: Each design shows the dimensions for *one-half* of each element, mounted on one side of the boom. The other half of each element is the same, mounted on the other side of the boom. The use of a tubing sleeve inside the center portion of the element is recommended, so that the element is not crushed by the mounting U-bolts. Unless otherwise noted, each section of tubing is made of 6061-T6 aluminum tubing, with a 0.058-inch wall thickness. This wall thickness

ensures that the next standard size of tubing can telescope with it. Each telescoping section is inserted 3 inches into the larger tubing, and is secured by one of the methods shown in Fig 11 in Chapter 20 of this book. Each antenna is designed with a driven-element length appropriate for a gamma type of matching network. The driven-element’s length may require slight readjustment for best match, particularly if a different matching network is used. *Do not change* either the lengths or the telescoping tubing schedule of the parasitic elements—they have been optimized for best performance and will not be affected by tuning of the driven element!

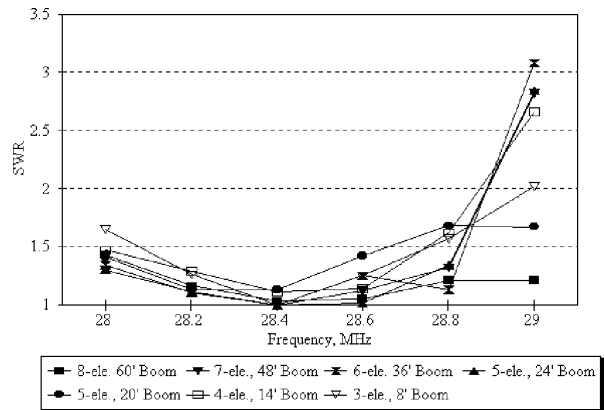
### 10-METER YAGIS

Fig 12 describes the electrical performance of seven optimized 10-meter Yagis with boom lengths between 8 to 60 feet. The end of each boom includes 3 inches of space for the reflector and last-director mounting plates. Fig 12A shows the free-space gain versus frequency for each antenna; 12B shows the front-to-rear ratio, and 12C shows the SWR versus frequency. Each antenna was designed to cover the lower half of the 10-meter band from 28.0 to 28.8 MHz, with SWR less than 2:1 and F/R better than 20 dB over that range.

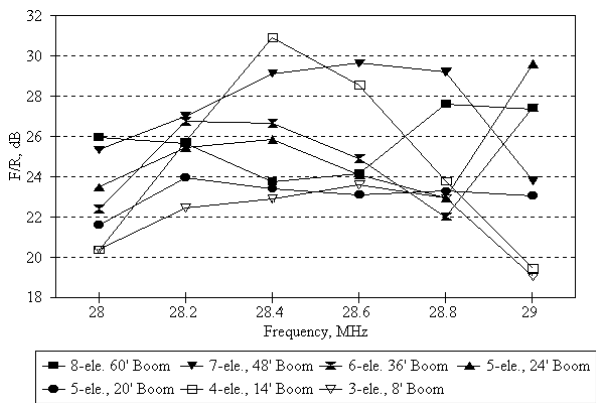
Fig 12D shows the taper schedule for two types of 10-meter elements. The heavy-duty design can survive 125-mph winds with no icing, and 88-mph winds with  $\frac{1}{4}$  inch of radial ice. The medium-duty design can handle 96-mph winds with no icing, and 68-mph winds with  $\frac{1}{4}$  inch of radial ice. The element-to-boom mounting plate for these Yagis is a 0.250-inch thick flat aluminum plate, 4 inches wide by 4 inches long. Each element is centered on the plate, held by two galvanized U-bolts with saddles. Another set of U-bolts with saddles is used to secure the mounting plate to the boom. Electrically each mounting plate is equivalent to a cylinder, with an effective diameter of 2.405 inches for the



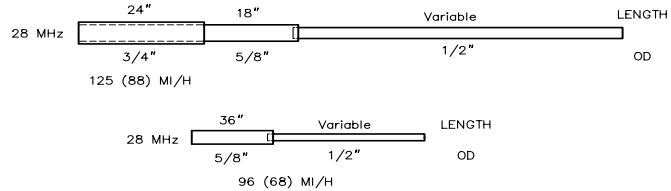
(A)



(C)



(B)



(D)

**Fig 12—Gain, F/R and SWR performance versus frequency for optimized 10-meter Yagis. At A, gain is shown versus frequency for seven 10-meter Yagis whose booms range from 8 feet to 60 feet long, and which have been optimized for better than 20 dB F/R and less than 2:1 SWR over the frequency range from 28.0 to 28.8 MHz. At B, front-to-rear ratio for these antennas is shown versus frequency, and at C, SWR is shown over the frequency range. At D, the taper schedule is shown for heavy-duty and for medium-duty 10-meter elements. The heavy-duty elements can withstand 125-mph winds without icing, and 88-mph winds with 1/4-inch radial ice. The medium-duty elements can survive 96-mph winds without icing, and 68-mph winds with 1/4-inch radial ice. The wall thickness for each telescoping section of 6061-T6 aluminum tubing is 0.058 inches, and the overlap at each telescoping junction is 3 inches.**

heavy-duty element, and 2.310 inches for the medium-duty element. The equivalent length on each side of the boom is 2 inches. These dimensions are used in the computer modeling program to simulate the effect of the mounting plate.

The second column in **Table 1** shows the spacing of each element relative to the next element in line on the boom, starting at the reflector, which itself is defined as being at the 0.000-inch reference point on the boom. The boom for antennas less than 30 feet long can be constructed of 2-inch OD tubing with 0.065-inch wall thickness. Designs larger than 30 feet long should use 3-inch OD heavy-wall tubing for the boom. Because each boom has 3 inches extra space at each end, the reflector is actually placed 3 inches from the end of the boom. For example, in the 310-08H.YAG design (3 elements on an 8-foot boom), the driven element is placed 36 inches ahead of the reflector, and the director is

placed 54 inches ahead of the driven element.

The next columns give the lengths for the variable tips for the heavy-duty and then the medium-duty elements. In the example above for the 310-08H.YAG, the heavy-duty reflector tip, made out of 1/2-inch OD tubing, sticks out 66.750 inches from the 5/8-inch OD tubing. Note that each telescoping piece of tubing overlaps 3 inches into the piece into which it fits, so the overall length of 1/8-inch OD tubing is 69.750 inches long for the reflector. The medium-duty reflector tip has 71.875 inches protruding from the 5/8-inch OD tube, and is 74.875 inches long overall. As previously stated, the dimensions are not extremely critical, although measurement accuracy to 1/8 inch is desirable.

The last row in each variable tip column shows the length of one-half of the “dummy element” torque compensator used to correct for uneven wind loading along

**Table 1****Optimized 10-Meter Yagi Designs****Three-element 10-meter Yagi, 8-foot boom**

<i>Element</i>	<i>Spacing</i>	<i>Heavy-Duty Tip</i>	<i>Medium-Duty Tip</i>
<i>File Name</i>		<i>310-08H.YAG</i>	<i>310-08M.YAG</i>
Reflector	0.000"	66.750"	71.875"
Driven Element	36.000"	57.625"	62.875"
Director 1	54.000"	53.125"	58.500"
Compensator	12" behind Dir. 1	19.000"	18.125"

**Four-element 10-meter Yagi, 14-foot boom**

<i>Element</i>	<i>Spacing</i>	<i>Heavy-Duty Tip</i>	<i>Medium-Duty Tip</i>
<i>File Name</i>		<i>410-14H.YAG</i>	<i>410-14M.YAG</i>
Reflector	0.000"	64.875"	70.000"
Driven Element	36.000"	58.625"	63.875"
Director 1	36.000"	57.000"	62.250"
Director 2	90.000"	47.750"	53.125"
Compensator	12" behind Dir. 2	22.000"	20.500"

**Five-element 10-meter Yagi, 24-foot boom**

<i>Element</i>	<i>Spacing, inches</i>	<i>Heavy-Duty Tip</i>	<i>Medium-Duty Tip</i>
<i>File Name</i>		<i>510-24H.YAG</i>	<i>510-24M.YAG</i>
Reflector	0.000"	65.625"	70.750"
Driven Element	36.000"	58.000"	63.250"
Director 1	36.000"	57.125"	62.375"
Director 2	99.000"	55.000"	60.250"
Director 3	111.000"	50.750"	56.125"
Compensator	12" behind Dir. 3	28.750"	26.750"

**Six-element 10-meter Yagi, 36-foot boom**

<i>Element</i>	<i>Spacing, inches</i>	<i>Heavy-Duty Tip</i>	<i>Medium-Duty Tip</i>
<i>File Name</i>		<i>610-36H.YAG</i>	<i>610-36M.YAG</i>
Reflector	0.000"	65.750"	70.875"
Driven Element	37.000"	57.625"	62.875"
Director 1	43.000"	57.125"	62.375"
Director 2	98.000"	54.875"	60.125"
Director 3	127.000"	53.875"	59.250"
Director 4	121.000"	49.875"	55.250"
Compensator	12" behind Dir. 4	32.000"	29.750"

**Seven-element 10-meter Yagi, 48-foot boom**

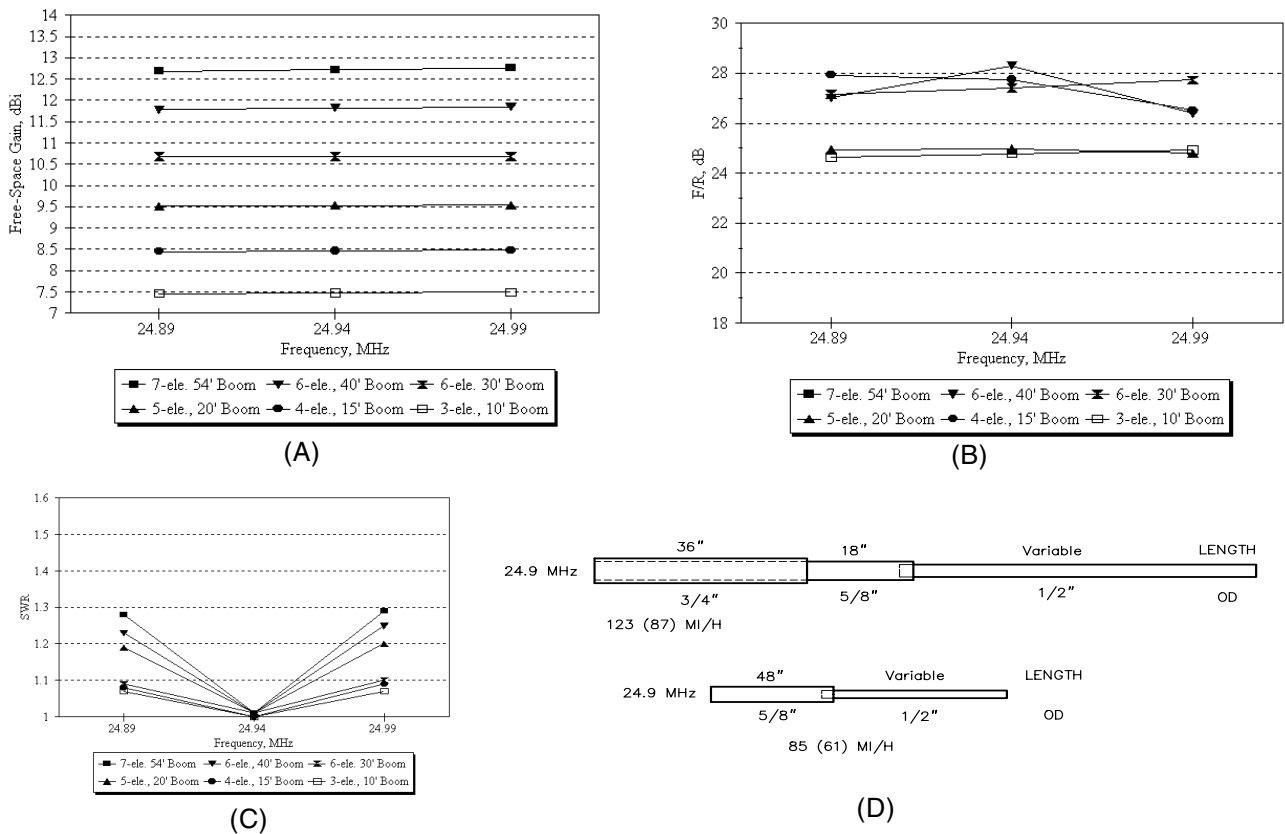
<i>Element</i>	<i>Spacing, inches</i>	<i>Heavy-Duty Tip</i>	<i>Medium-Duty Tip</i>
<i>File Name</i>		<i>710-48H.YAG</i>	<i>710-48M.YAG</i>
Reflector	0.000"	65.375"	70.500"
Driven Element	37.000"	58.125"	63.375"
Director 1	37.000"	57.500"	62.750"
Director 2	96.000"	54.875"	60.125"
Director 3	130.000"	52.250"	57.625"
Director 4	154.000"	52.625"	58.000"
Director 5	116.000"	49.875"	55.250"
Compensator	12" behind Dir. 5	35.750"	33.750"

**Eight-element 10-meter Yagi, 60-foot boom**

<i>Element</i>	<i>Spacing, inches</i>	<i>Heavy-Duty Tip</i>	<i>Medium-Duty Tip</i>
<i>File Name</i>		<i>810-60H.YAG</i>	<i>810-60M.YAG</i>
Reflector	0.000"	65.000"	70.125"
Driven Element	42.000"	57.375"	62.625"
Director 1	37.000"	57.125"	62.375"
Director 2	87.000"	55.375"	60.625"
Director 3	126.000"	53.250"	58.625"
Director 4	141.000"	51.875"	57.250"
Director 5	157.000"	52.500"	57.875"
Director 6	121.000"	50.125"	55.500"
Compensator	12" behind Dir. 6	59.375"	55.125"

These 10-meter Yagi designs are optimized for > 20 dB F/R, and SWR < 2:1 over frequency range from 28.000 to 28.800 MHz, for heavy-duty elements (125-mph wind survival) and for medium-duty (96-mph wind survival). For coverage from 28.8 to 29.7 MHz, subtract 2.000 inches from end of each element, but leave element spacings the same as shown here. Only element tip dimensions are shown, and all dimensions are in inches. See [Fig 12D](#) for element telescoping tubing schedule. Torque compensator element is made of 2.5" OD PVC water pipe placed 12 inches behind last director. Dimensions shown for compensators are one-half of total length, centered on boom.





**Fig 13—Gain, F/R and SWR performance versus frequency for optimized 12-meter Yagis. At A, gain is shown versus frequency for six 12-meter Yagis whose booms range from 10 feet to 54 feet long, and which have been optimized for better than 20 dB F/R and less than 2:1 SWR over the narrow 12-meter band from 24.89 to 24.99 MHz. At B, front-to-rear ratio for these antennas is shown versus frequency, and at C, SWR over the frequency range is shown. At D, the taper schedule for heavy-duty and for medium-duty 12-meter elements is shown. The heavy-duty elements can withstand 123-mph winds without icing, and 87-mph winds with 1/4-inch radial ice. The medium-duty elements can survive 85-mph winds without icing, and 61-mph winds with 1/4-inch radial ice. The wall thickness for each telescoping section of 6061-T6 aluminum tubing is 0.058 inches, and the overlap at each telescoping junction is 3 inches.**

the boom. This compensator is made from 2.5 inches OD PVC water pipe mounted to an element-to-boom plate like those used for each element. The compensator is mounted 12 inches behind the last director, the first director in the case of the 3-element 310-08.YAG antenna. Note that the heavy-duty elements require a correspondingly longer torque compensator than do the medium-duty elements.

### 12-METER YAGIS

**Fig 13** describes the electrical performance of six optimized 12-meter Yagis with boom lengths between 10 to 54 feet. The end of each boom includes 3 inches of space for the reflector and last director mounting plates. The narrow frequency width of the 12-meter band allows the performance to be optimized easily. Fig 13A shows the free-space gain versus frequency for each antenna; 13B shows the front-to-rear ratio, and 13C shows the SWR versus frequency. Each antenna was designed to cover the narrow 12-meter band from 24.89 to 24.99 MHz, with SWR less than 2:1 and F/R better than 20 dB over that range.

Fig 13D shows the taper schedule for two types of 12-meter elements. The heavy-duty design can survive 123-mph winds with no icing, and 87-mph winds with 1/4 inch of radial ice. The medium-duty design can handle 85-mph winds with no icing, and 61-mph winds with 1/4 inch of radial ice. The element-to-boom mounting plate for these Yagis is a 0.375 inch thick flat aluminum plate, 5 inch wide by 6 inches long. Electrically, each mounting plate is equivalent to a cylinder, with an effective diameter of 2.9447 inches for the heavy-duty element, and 2.8568 inches for the medium-duty element. The equivalent length on each side of the boom is 3 inches. As usual, the torque compensator is mounted 12 inches behind the last director.

### 15-METER YAGIS

**Fig 14** describes the electrical performance of seven optimized 15-meter Yagis with boom lengths between 12 feet to a spectacular 80 feet. The end of each boom includes 3 inches of space for the reflector and last-director

**Table 2**  
**Optimized 12-Meter Yagi Designs**

**Three-element 12-meter Yagi, 10-foot boom**

<i>Element</i>	<i>Spacing, inches</i>	<i>Heavy-Duty Tip</i>	<i>Medium-Duty Tip</i>
<i>File Name</i>		<i>312-10H.YAG</i>	<i>312-10M.YAG</i>
Reflector	0.000"	69.000"	73.875"
Driven Element	40.000"	59.125"	64.250"
Director 1	74.000"	54.000"	59.125"
Compensator	12" behind Dir. 1	13.625"	12.000"

**Four-element 12-meter Yagi, 14-foot boom**

<i>Element</i>	<i>Spacing, inches</i>	<i>Heavy-Duty Tip</i>	<i>Medium-Duty Tip</i>
<i>File Name</i>		<i>412-14H.YAG</i>	<i>412-14M.YAG</i>
Reflector	0.000"	66.875"	71.875"
Driven Element	46.000"	60.625"	65.625"
Director 1	46.000"	58.625"	63.750"
Director 2	82.000"	50.875"	56.125"
Compensator	12" behind Dir. 2	16.375"	14.500"

**Five-element 12-meter Yagi, 20-foot boom**

<i>Element</i>	<i>Spacing, inches</i>	<i>Heavy-Duty Tip</i>	<i>Medium-Duty Tip</i>
<i>File Name</i>		<i>512-20H.YAG</i>	<i>512-20M.YAG</i>
Reflector	0.000"	69.750"	74.625"
Driven Element	46.000"	61.750"	66.750"
Director 1	46.000"	60.500"	65.500"
Director 2	48.000"	55.500"	60.625"
Director 3	94.000"	54.625"	59.750"
Compensator	12" behind Dir. 3	22.125"	19.625"

**Six-element 12-meter Yagi, 30-foot boom**

<i>Element</i>	<i>Spacing, inches</i>	<i>Heavy-Duty Tip</i>	<i>Medium-Duty Tip</i>
<i>File Name</i>		<i>612-30H.YAG</i>	<i>612-30M.YAG</i>
Reflector	0.000"	68.125"	73.000"
Driven Element	46.000"	61.750"	66.750"
Director 1	46.000"	60.250"	65.250"
Director 2	72.000"	52.375"	57.625"
Director 3	75.000"	57.625"	62.750"
Director 4	114.000"	53.625"	58.750"
Compensator	12" behind Dir. 4	30.000"	26.250"

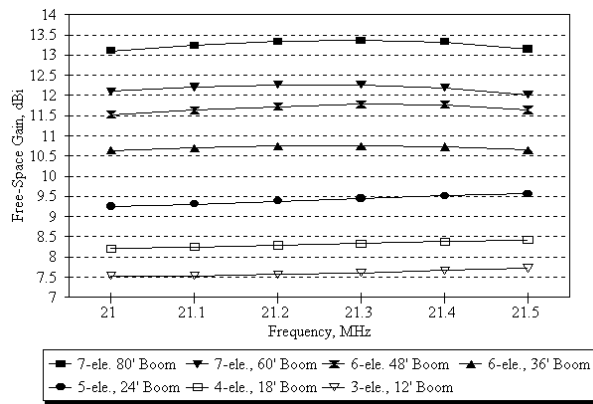
**Six-element 12-meter Yagi, 40-foot boom**

<i>Element</i>	<i>Spacing, inches</i>	<i>Heavy-Duty Tip</i>	<i>Medium-Duty Tip</i>
<i>File Name</i>		<i>612-40H.YAG</i>	<i>612-40M.YAG</i>
Reflector	0.000"	67.000"	71.875"
Driven Element	46.000"	60.125"	65.125"
Director 1	46.000"	57.375"	62.500"
Director 2	91.000"	57.375"	62.500"
Director 3	157.000"	57.000"	62.125"
Director 4	134.000"	54.375"	59.500"
Compensator	12" behind Dir. 4	36.500"	31.625"

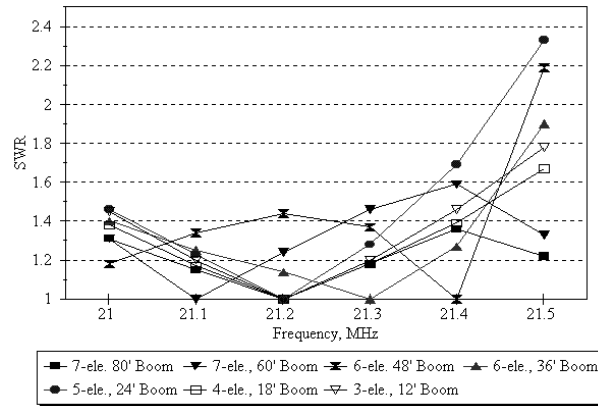
**Seven-element 12-meter Yagi, 54-foot boom**

<i>Element</i>	<i>Spacing, inches</i>	<i>Heavy-Duty Tip</i>	<i>Medium-Duty Tip</i>
<i>File Name</i>		<i>712-54H.YAG</i>	<i>712-54M.YAG</i>
Reflector	0.000"	67.125"	72.000"
Driven Element	46.000"	60.500"	65.500"
Director 1	46.000"	56.750"	61.875"
Director 2	75.000"	58.000"	63.125"
Director 3	161.000"	55.625"	60.750"
Director 4	174.000"	56.000"	61.125"
Director 5	140.000"	53.125"	58.375"
Compensator	12" behind Dir. 5	43.125"	37.500"

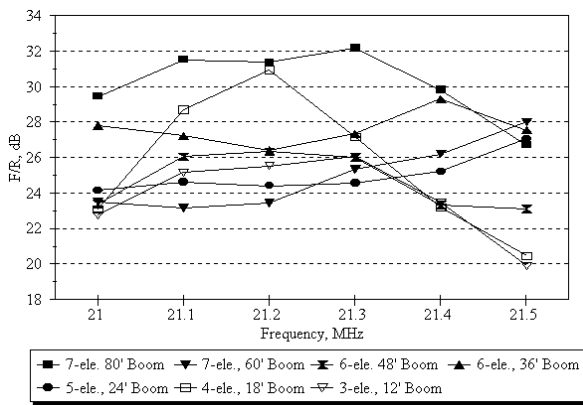
These 12-meter Yagi designs were optimized for > 20 dB F/R, and SWR < 2:1 over frequency range from 24.890 to 24.990 MHz, for heavy-duty elements (123-mph wind survival) and for medium-duty (85-mph wind survival). Only element tip dimensions are shown, and all dimensions are in inches. See Fig 13D for element telescoping tubing schedule. Torque compensator element is made of 2.5" OD PVC water pipe placed 12" behind the last director. Dimensions shown for compensators are one-half of total length, centered on boom.



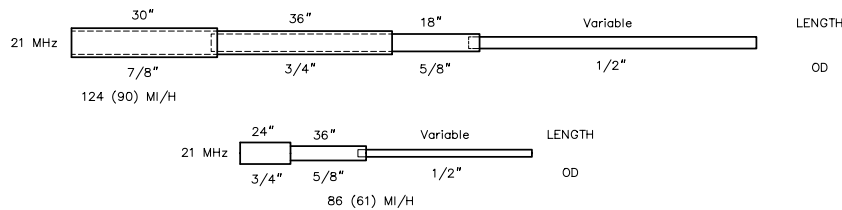
(A)



(C)



(B)



(D)

**Fig 14—Gain, F/R and SWR performance versus frequency for optimized 15-meter Yagis. At A, gain versus frequency is shown for seven 15-meter Yagis whose booms range from 12 feet to 80 feet long, and which have been optimized for better than 20 dB F/R and less than 2:1 SWR over the frequency range from 21.0 to 21.45 MHz. At B, front-to-rear ratio for these antennas is shown versus frequency, and at C, SWR over the frequency range is shown. At D, the taper schedule for heavy-duty and for medium-duty 15-meter elements is shown. The heavy-duty elements can withstand 124-mph winds without icing, and 90-mph winds with 1/4-inch radial ice. The medium-duty elements can survive 86-mph winds without icing, and 61-mph winds with 1/4-inch radial ice. The wall thickness for each telescoping section of 6061-T6 aluminum tubing is 0.058 inches, and the overlap at each telescoping junction is 3 inches.**

mounting plates. Fig 14A shows the free-space gain versus frequency for each antenna; 14B shows the worst-case front-to-rear ratio, and 14C shows the SWR versus frequency. Each antenna was designed to cover the full 15-meter band from 21.000 to 21.450 MHz, with SWR less than 2:1 and F/R ratio better than 20 dB over that range.

Fig 14D shows the taper schedule for two types of 15-meter elements. The heavy-duty design can survive 124-mph winds with no icing, and 90-mph winds with 1/4-inch of radial ice. The medium-duty design can handle

86-mph winds with no icing, and 61-mph winds with 1/4-inch of radial ice. The element-to-boom mounting plate for these Yagis is a 0.375-inch thick flat aluminum plate, 5 inches wide by 6 inches long. Electrically, each mounting plate is equivalent to a cylinder, with an effective diameter of 3.0362 inches for the heavy-duty element, and 2.9447 inches for the medium-duty element. The equivalent length on each side of the boom is 3 inches. As usual, the torque compensator is mounted 12 inches behind the last director.

**Table 3****Optimized 15-Meter Yagi Designs****Three-element 15-meter Yagi, 12-foot boom**

<i>Element</i>	<i>Spacing</i>	<i>Heavy-Duty Tip</i>	<i>Medium-Duty Tip</i>
<i>File Name</i>	<i>12' boom</i>	<i>315-12H.YAG</i>	<i>315-12M.YAG</i>
Reflector	0.000"	61.375"	83.750"
Driven Element	48.000"	49.625"	72.625"
Director 1	92.000"	43.500"	66.750"
Compensator	12" behind Dir. 1	34.750"	37.625"

**Four-element 15-meter Yagi, 18-foot boom**

<i>Element</i>	<i>Spacing</i>	<i>Heavy-Duty Tip</i>	<i>Medium-Duty Tip</i>
<i>File Name</i>		<i>415-18H.YAG</i>	<i>415-18M.YAG</i>
Reflector	0.000"	59.750"	82.250"
Driven Element	56.000"	50.875"	73.875"
Director 1	56.000"	48.000"	71.125"
Director 2	98.000"	36.625"	60.250"
Compensator	12" behind Dir. 2	20.875"	18.625"

**Five-element 15-meter Yagi, 24-foot boom**

<i>Element</i>	<i>Spacing</i>	<i>Heavy-Duty Tip</i>	<i>Medium-Duty Tip</i>
<i>File Name</i>		<i>515-24H.YAG</i>	<i>515-24M.YAG</i>
Reflector	0.000"	62.000"	84.375"
Driven Element	48.000"	52.375"	75.250"
Director 1	48.000"	47.875"	71.000"
Director 2	52.000"	47.000"	70.125"
Director 3	134.000"	41.000"	64.375"
Compensator	12" behind Dir. 3	40.250"	35.125"

**Six-element 15-meter Yagi, 36-foot boom**

<i>Element</i>	<i>Spacing</i>	<i>Heavy-Duty Tip</i>	<i>Medium-Duty Tip</i>
<i>File Name</i>		<i>615-36H.YAG</i>	<i>615-36M.YAG</i>
Reflector	0.000"	61.000"	83.375"
Driven Element	53.000"	51.375"	74.250"
Director 1	56.000"	49.125"	72.125"
Director 2	59.000"	45.125"	68.375"
Director 3	116.000"	47.875"	71.000"
Director 4	142.000"	42.000"	65.375"
Compensator	12" behind Dir. 4	45.500"	39.750"

**Six-element 15-meter Yagi, 48-foot boom**

<i>Element</i>	<i>Spacing</i>	<i>Heavy-Duty Tip</i>	<i>Medium-Duty Tip</i>
<i>File Name</i>		<i>615-48H.YAG</i>	<i>615-48M.YAG</i>
Reflector	0.000"	60.500"	83.000"
Driven Element	48.000"	50.875"	72.875"
Director 1	48.000"	51.250"	74.125"
Director 2	125.000"	48.000"	71.125"
Director 3	190.000"	45.500"	68.750"
Director 4	161.000"	42.000"	65.375"
Compensator	12" behind Dir. 4	51.500"	45.375"

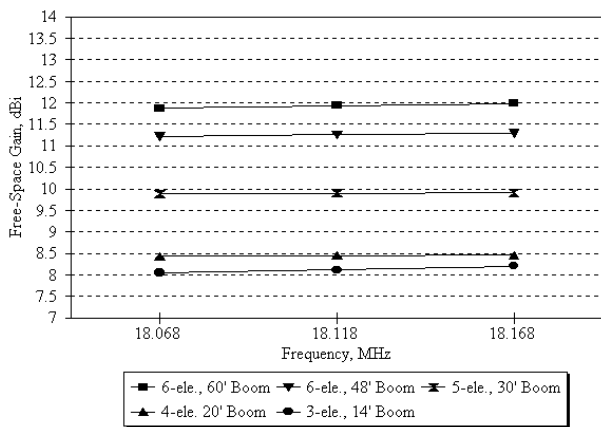
**Seven-element 15-meter Yagi, 60-foot boom**

<i>Element</i>	<i>Spacing</i>	<i>Heavy-Duty Tip</i>	<i>Medium-Duty Tip</i>
<i>File Name</i>		<i>715-60H.YAG</i>	<i>715-60M.YAG</i>
Reflector	0.000"	59.750"	82.250"
Driven Element	48.000"	51.375"	74.250"
Director 1	48.000"	52.000"	74.875"
Director 2	93.000"	49.500"	72.500"
Director 3	173.000"	44.125"	67.375"
Director 4	197.000"	45.500"	68.750"
Director 5	155.000"	41.750"	65.125"
Compensator	12" behind Dir. 5	58.500"	51.000"

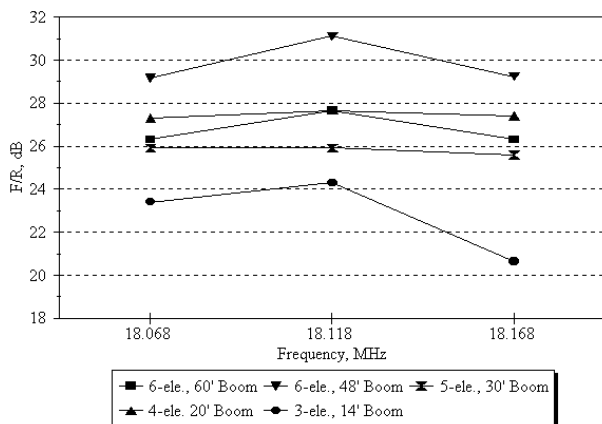
**Eight-element 15-meter Yagi, 80-foot boom**

<i>Element</i>	<i>Spacing</i>	<i>Heavy-Duty Tip</i>	<i>Medium-Duty Tip</i>
<i>File Name</i>		<i>815-80H.YAG</i>	<i>815-80M.YAG</i>
Reflector	0.000"	60.625"	83.125"
Driven Element	56.000"	51.250"	74.125"
Director 1	48.000"	51.500"	74.375"
Director 2	115.000"	48.375"	71.500"
Director 3	164.000"	45.750"	69.000"
Director 4	202.000"	43.125"	66.500"
Director 5	206.000"	44.750"	68.000"
Director 6	163.000"	40.875"	64.250"
Compensator	12" behind Dir. 6	95.000"	83.375"

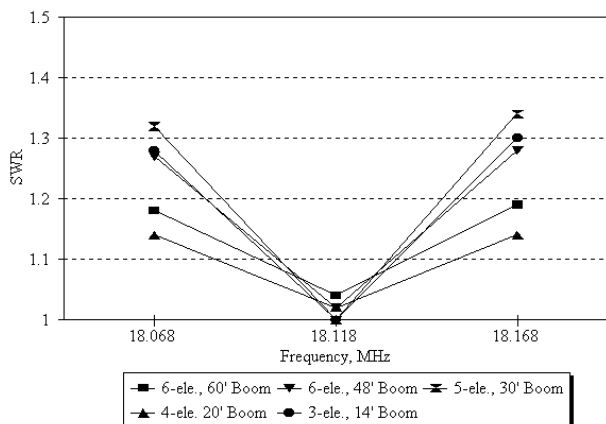
These 15-meter Yagi designs are optimized for > 20 dB F/R, and SWR < 2:1 over entire frequency range from 21.000 to 21.450 MHz, for heavy-duty elements (124-mph wind survival) and for medium-duty (86-mph wind survival). Only element tip dimensions are shown. See [Fig 14D](#) for element telescoping tubing schedule. All dimensions are in inches. Torque compensator element is made of 2.5" OD PVC water pipe placed 12" behind last director, and dimensions shown for compensators are one-half of total length, centered on boom.



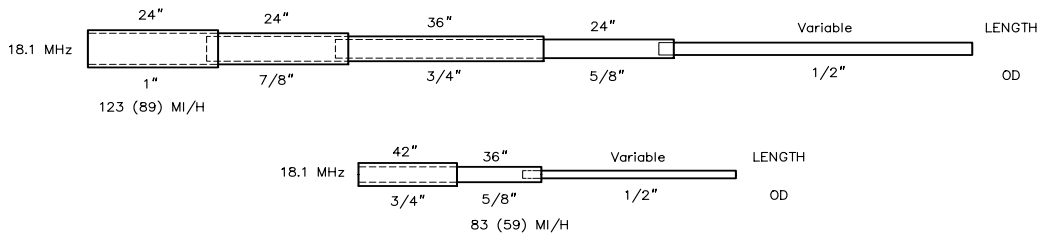
(A)



(B)



(C)



(D)

### 17-METER YAGIS

Fig 15 describes the electrical performance of five optimized 17-meter Yagis with boom lengths between 14 to a heroic 60 feet. As usual, the end of each boom includes 3 inches of space for the reflector and last director mounting plates. Fig 15A shows the free-space gain versus frequency for each antenna; 15B shows the worst-case front-to-rear ratio, and 15C shows the SWR versus frequency. Each antenna was designed to cover the narrow 17-meter band from 18.068 to 18.168 MHz, with SWR less than 2:1 and F/R ratio better than 20 dB over that range.

Fig 15D shows the taper schedule for two types of

Fig 15—Gain, F/R and SWR performance versus frequency for optimized 17-meter Yagis. At A, gain versus frequency is shown for five 17-meter Yagis whose booms range from 14 feet to 60 feet long, and which have been optimized for better than 20 dB F/R and less than 2:1 SWR over the narrow 17-meter band from 18.068 to 18.168 MHz. At B, front-to-rear ratio for these antennas is shown versus frequency, and at C, SWR over the frequency range is shown. At D, the taper schedule for heavy-duty and for medium-duty 17-meter elements is shown. The heavy-duty elements can withstand 123-mph winds without icing, and 89-mph winds with 1/4-inch radial ice. The medium-duty elements can survive 83-mph winds without icing, and 59-mph winds with 1/4-inch radial ice. The wall thickness for each telescoping section of 6061-T6 aluminum tubing is 0.058 inches, and the overlap at each telescoping junction is 3 inches.

17-meter elements. The heavy-duty design can survive 123-mph winds with no icing, and 83-mph winds with 1/4 inch of radial ice. The medium-duty design can handle 83-mph winds with no icing, and 59-mph winds with 1/4 inch of radial ice. The element-to-boom mounting plate for these Yagis is a 0.375-inch thick flat aluminum plate, 6 inches wide by 8 inches long. Electrically, each mounting plate is equivalent to a cylinder, with an effective diameter of 3.5122 inches for the heavy-duty element, and 3.3299 inches for the medium-duty element. The equivalent length on each side of the boom is 4 inches. As usual, the torque compensator is mounted 12 inches behind the last director.

**Table 4****Optimized 17-meter Yagi Designs****Three-element 17-meter Yagi, 14-foot boom**

<i>Element</i>	<i>Spacing</i>	<i>Heavy-Duty Tip</i>	<i>Medium-Duty Tip</i>
<i>File Name</i>		<i>317-14H.YAG</i>	<i>317-14M.YAG</i>
Reflector	0.000"	60.125"	88.250
Driven Element	65.000"	56.625"	81.125
Director 1	97.000"	48.500"	77.250"
Compensator	12" behind Dir. 1	12.625"	10.750

**Four-element 17-meter Yagi, 20-foot boom**

<i>Element</i>	<i>Spacing</i>	<i>Heavy-Duty Tip</i>	<i>Medium-Duty Tip</i>
<i>File Name</i>		<i>417-20H.YAG</i>	<i>417-20M.YAG</i>
Reflector	0.000"	61.500"	89.500"
Driven Element	48.000"	54.250"	82.625"
Director 1	48.000"	52.625"	81.125"
Director 2	138.000"	40.500"	69.625"
Compensator	12" behind Dir. 2	42.500"	36.250"

**Five-element 17-meter Yagi, 30-foot boom**

<i>Element</i>	<i>Spacing</i>	<i>Heavy-Duty Tip</i>	<i>Medium-Duty Tip</i>
<i>File Name</i>		<i>517-30H.YAG</i>	<i>517-30M.YAG</i>
Reflector	0.000"	61.875"	89.875"
Driven Element	48.000"	52.625"	81.125"
Director 1	52.000"	49.625"	78.250"
Director 2	93.000"	49.875"	78.500"
Director 3	161.000"	42.500"	72.500"
Compensator	12" behind Dir. 3	54.375"	45.875"

**Six-element 17-meter Yagi, 48-foot boom**

<i>Element</i>	<i>Spacing</i>	<i>Heavy-Duty Tip</i>	<i>Medium-Duty Tip</i>
<i>File Name</i>		<i>617-48H.YAG</i>	<i>617-48M.YAG</i>
Reflector	0.000"	62.250"	90.250"
Driven Element	52.000"	52.625"	81.125"
Director 1	51.000"	45.500"	74.375"
Director 2	87.000"	47.875"	76.625"
Director 3	204.000"	47.000"	75.875"
Director 4	176.000"	42.000"	71.125"
Compensator	12" behind Dir. 4	68.250"	57.500"

**Six-element 17-meter Yagi, 60-foot boom**

<i>Element</i>	<i>Spacing</i>	<i>Heavy-Duty Tip</i>	<i>Medium-Duty Tip</i>
<i>File Name</i>		<i>617-60H.YAG</i>	<i>617-60M.YAG</i>
Reflector	0.000"	61.250"	89.250"
Driven Element	54.000"	54.750"	83.125"
Director 1	54.000"	52.250"	80.750"
Director 2	180.000"	46.000"	74.875"
Director 3	235.000"	44.625"	73.625"
Director 4	191.000"	41.500"	70.625"
Compensator	12" behind Dir. 4	62.875"	53.000"

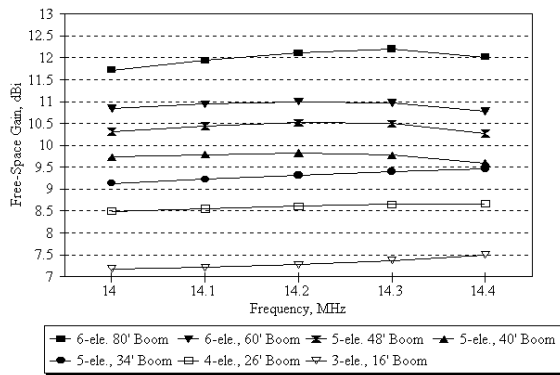
These 17-meter Yagi designs are optimized for > 20 dB F/R, and SWR < 2:1 over entire frequency range from 18.068 to 18.168 MHz, for heavy-duty elements (123-mph wind survival) and for medium-duty (83-mph wind survival). Only element tip dimensions are shown. All dimensions are in inches. Torque compensator element is made of 2.5" OD PVC water pipe placed 12" behind last director, and dimensions shown for compensators are one-half of total length, centered on boom.

**20-METER YAGIS**

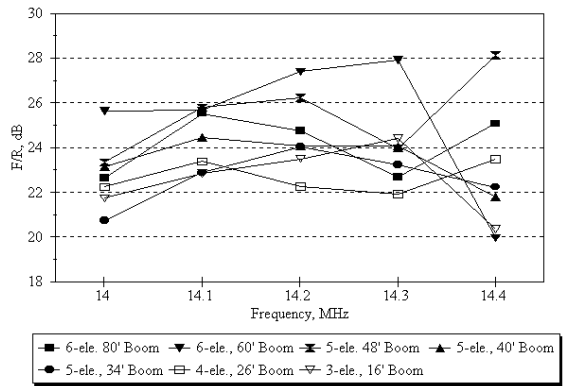
**Fig 16** describes the electrical performance of seven optimized 20-meter Yagis with boom lengths between 16 to a giant 80 feet. As usual, the end of each boom includes 3 inches of space for the reflector and last director mounting plates. Fig 16A shows the free-space gain versus frequency for each antenna; 16B shows the front-to-rear ratio, and 16C shows the SWR versus frequency. Each antenna was designed to cover the complete 20-meter band from 14.000

to 14.350 MHz, with SWR less than 2:1 and F/R ratio better than 20 dB over that range.

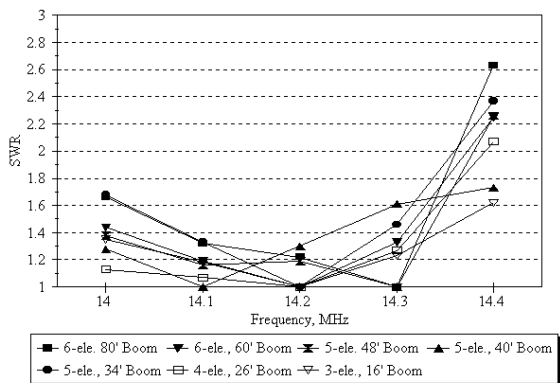
**Fig 16D** shows the taper schedule for two types of 20-meter elements. The heavy-duty design can survive 122-mph winds with no icing, and 89-mph winds with 1/4-inch of radial ice. The medium-duty design can handle 82-mph winds with no icing, and 60-mph winds with 1/4 inch of radial ice. The element-to-boom mounting plate for these Yagis is a 0.375-inch thick flat aluminum plate, 6 inches



(A)

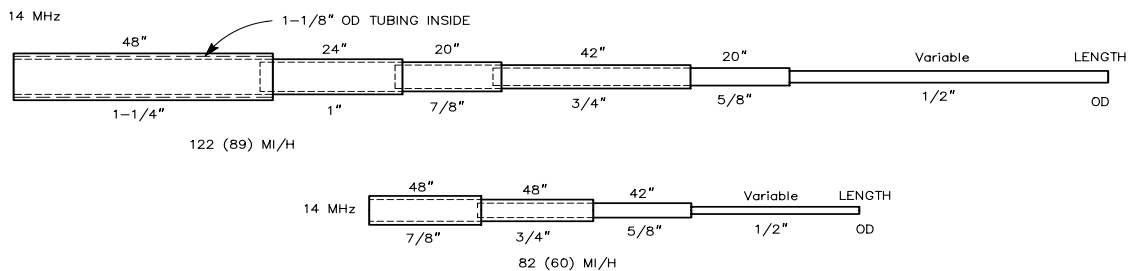


(B)



(C)

**Fig 16—Gain, F/R and SWR performance versus frequency for optimized 20-meter Yagis. At A, gain versus frequency is shown for seven 20-meter Yagis whose booms range from 16 feet to 80 feet long, and which have been optimized for better than 20 dB F/R and less than 2:1 SWR over the frequency range from 14.0 to 14.35 MHz. At B, front-to-rear ratio for these antennas is shown versus frequency, and at C, SWR over the frequency range is shown. At D, the taper schedule for heavy-duty and for medium-duty 20-meter elements is shown. The heavy-duty elements can withstand 122-mph winds without icing, and 89-mph winds with 1/4-inch radial ice. The medium-duty elements can survive 82-mph winds without icing, and 60-mph winds with 1/4-inch radial ice. The wall thickness for each telescoping section of 6061-T6 aluminum tubing is 0.058 inches, and the overlap at each telescoping junction is 3 inches.**



(D)

wide by 8 inches long. Electrically, each mounting plate is equivalent to a cylinder, with an effective diameter of 3.7063 inches for the heavy-duty element, and 3.4194 inches for the medium-duty element. The equivalent length on each side of the boom is 4 inches. As usual, the torque compensator is mounted 12 inches behind the last director.

### 30-METER YAGIS

**Fig 17** describes the electrical performance of three optimized 30-meter Yagis with boom lengths between 15 to 34 feet. Because of the size and weight of the elements alone for Yagis on this band, only 2-element and 3-element designs are described. The front-to-rear ratio requirement for the 2-element antenna is relaxed to be greater than 10 dB over

the band from 10.100 to 10.150 MHz, while that for the 3-element designs is kept at greater than 20 dB over that frequency range.

As usual, the end of each boom includes 3 inches of space for the reflector and last director mounting plates. **Fig 17A** shows the free-space gain versus frequency for each antenna; **17B** shows the worst-case front-to-rear ratio, and **17C** shows the SWR versus frequency.

**Fig 17D** shows the taper schedule for the 30-meter elements. Note that the wall thickness of the first two sections of tubing is 0.083 inches, rather than 0.058 inches. This heavy-duty element design can survive 107-mph winds with no icing, and 93-mph winds with 1/4 inch of radial ice. The element-to-boom mounting plate for these Yagis is a

**Table 5****Optimized 20-Meter Yagi Designs****Three-element 20-meter Yagi, 16-foot boom**

<i>Element</i>	<i>Spacing</i>	<i>Heavy-Duty Tip</i>	<i>Medium-Duty Tip</i>
<i>File Name</i>		<i>320-16H.YAG</i>	<i>320-16M.YAG</i>
Reflector	0.000"	69.625"	81.625"
Driven Element	80.000"	51.250"	64.500"
Director 1	106.000"	42.625"	56.375"
Compensator	12" behind Dir. 1	33.375"	38.250"

**Four-element 20-meter Yagi, 26-foot boom**

<i>Element</i>	<i>Spacing</i>	<i>Heavy-Duty Tip</i>	<i>Medium-Duty Tip</i>
<i>File Name</i>		<i>420-26H.YAG</i>	<i>420-26M.YAG</i>
Reflector	0.000"	65.625"	76.875"
Driven Element	72.000"	53.375"	65.375"
Director 1	60.000"	51.750"	63.875"
Director 2	174.000"	38.625"	51.500"
Compensator	12" behind Dir. 2	54.250"	44.250"

**Five-element 20-meter Yagi, 34-foot boom**

<i>Element</i>	<i>Spacing</i>	<i>Heavy-Duty Tip</i>	<i>Medium-Duty Tip</i>
<i>File Name</i>		<i>520-34H.YAG</i>	<i>520-34M.YAG</i>
Reflector	0.000"	68.625"	80.750"
Driven Element	72.000"	52.250"	65.375"
Director 1	71.000"	45.875"	59.375"
Director 2	68.000"	45.875"	59.375"
Director 3	191.000"	37.000"	51.000"
Compensator	12" behind Dir. 3	69.250"	56.250"

**Five-element 20-meter Yagi, 40-foot boom**

<i>Element</i>	<i>Spacing</i>	<i>Heavy-Duty Tip</i>	<i>Medium-Duty Tip</i>
<i>File Name</i>		<i>520-40H.YAG</i>	<i>520-40M.YAG</i>
Reflector	0.000"	68.375"	80.500"
Driven Element	72.000"	53.500"	66.625"
Director 1	72.000"	51.500"	64.625"
Director 2	139.000"	48.375"	61.750"
Director 3	191.000"	38.000"	52.000"
Compensator	12" behind Dir. 3	69.750"	56.750"

**Five-element 20-meter Yagi, 48-foot boom**

<i>Element</i>	<i>Spacing</i>	<i>Heavy-Duty Tip</i>	<i>Medium-Duty Tip</i>
<i>File Name</i>		<i>520-48H.YAG</i>	<i>520-48M.YAG</i>
Reflector	0.000"	66.250"	78.500"
Driven Element	72.000"	52.375"	65.500"
Director 1	88.000"	50.500"	63.750"
Director 2	199.000"	47.375"	60.875"
Director 3	211.000"	39.750"	53.625"
Compensator	12" behind Dir. 3	70.325"	57.325"

**Six-element 20-meter Yagi, 60-foot boom**

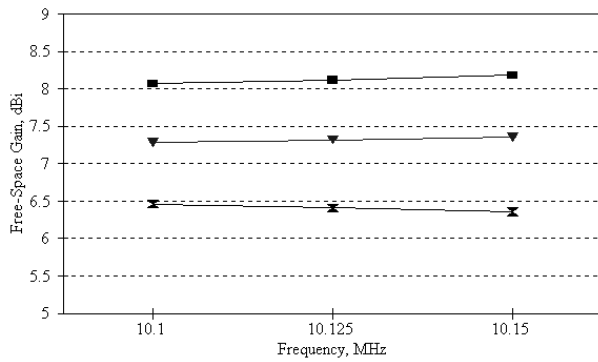
<i>Element</i>	<i>Spacing</i>	<i>Heavy-Duty Tip</i>	<i>Medium-Duty Tip</i>
<i>File Name</i>		<i>620-60H.YAG</i>	<i>620-60M.YAG</i>
Reflector	0.000"	67.000"	79.250"
Driven Element	84.000"	52.375"	65.500"
Director 1	91.000"	45.125"	58.750"
Director 2	130.000"	41.375"	55.125"
Director 3	210.000"	46.875"	60.375"
Director 4	199.000"	39.125"	53.000"
Compensator	12" behind Dir. 4	72.875"	59.250"

**Six-element 20-meter Yagi, 80-foot boom**

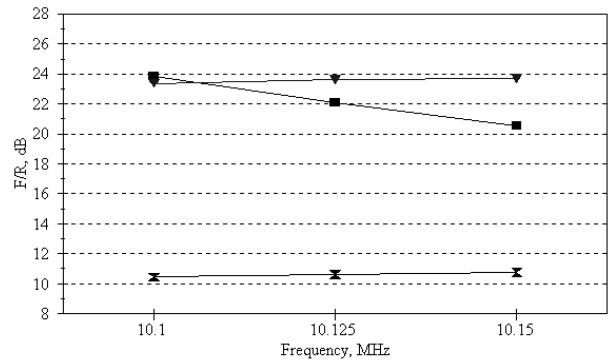
<i>Element</i>	<i>Spacing</i>	<i>Heavy-Duty Tip</i>	<i>Medium-Duty Tip</i>
<i>File Name</i>		<i>620-80H.YAG</i>	<i>620-80M.YAG</i>
Reflector	0.000"	66.125"	78.375"
Driven Element	72.000"	52.375"	65.500"
Director 1	122.000"	49.125"	62.500"
Director 2	229.000"	44.500"	58.125"
Director 3	291.000"	42.625"	56.375"
Director 4	240.000"	38.750"	52.625"
Compensator	12" behind Dir. 4	78.750"	64.125"

These 20-meter Yagi designs are optimized for > 20 dB F/R, and SWR < 2:1 over entire frequency range from 14.000 to 14.350 MHz, for heavy-duty elements (122-mph wind survival) and for medium-duty (82-mph wind survival). Only element tips are shown. See [Fig 16D](#) for element telescoping tubing schedule. All dimensions are in inches. Torque compensator element is made of 2.5" OD PVC water pipe placed 12" behind last director, and dimensions shown for compensators are one-half of total length, centered on boom.

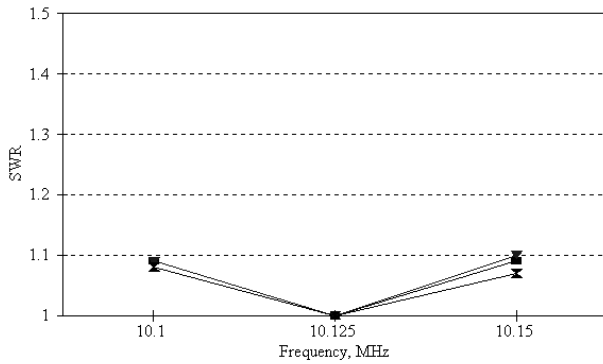




(A)

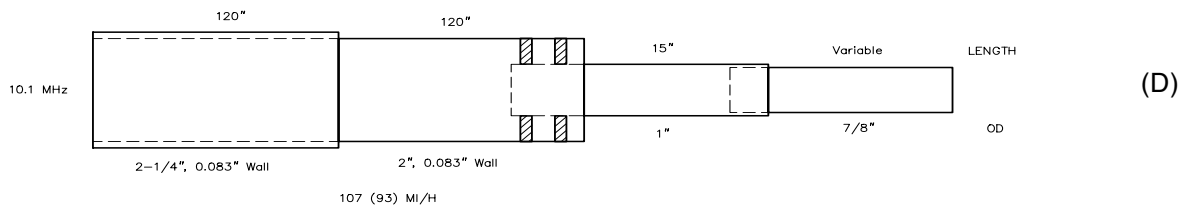


(B)



(C)

**Fig 17—Gain, F/R and SWR performance versus frequency for optimized 30-meter Yagis. At A, gain versus frequency is shown for three 30-meter Yagis whose booms range from 15 feet to 34 feet long, and which have been optimized for better than 10 dB F/R and less than 2:1 SWR over the frequency range from 10.1 to 10.15 MHz. At B, front-to-rear ratio for these antennas is shown versus frequency, and at C, SWR over the frequency range is shown. At D, the taper schedule is shown for heavy-duty 30-meter elements, which can withstand 107-mph winds without icing, and 93-mph winds with 1/4-inch radial ice. Except for the 2 1/4-inch and 2-inch sections, which have 0.083-inch thick walls, the wall thickness for the other telescoping sections of 6061-T6 aluminum tubing is 0.058 inches, and the overlap at the 1-inch telescoping junction with the 7/8-inch section is 3 inches. The 2-inch section utilizes two machined aluminum reducers to accommodate the 1-inch tubing.**



(D)

0.500-inch thick flat aluminum plate, 6 inches wide by 24 inches long. Electrically, each mounting plate is equivalent to a cylinder, with an effective diameter of 4.684 inches. The equivalent length on each side of the boom is 12 inches. These designs require no torque compensator.

#### 40-METER YAGIS

Fig 18 describes the electrical performance of three optimized 40-meter Yagis with boom lengths between 20 to 48 feet. Like the 30-meter antennas, because of the size and weight of the elements for a 40-meter Yagi, only 2-element and 3-element designs are described. The front-to-rear ratio requirement for the 2-element antenna is relaxed to be greater than 10 dB over the band from 7.000 to 7.300 MHz, while the goal for the 3-element designs is 20 dB over the frequency range of 7.000 to 7.200 MHz. It is exceedingly difficult to

hold the F/R greater than 20 dB over the entire 40-meter band without sacrificing excessive gain with a 3-element design.

As usual, the end of each boom includes 3 inches of space for the reflector and last director mounting plates. Fig 18A shows the free-space gain versus frequency for each antenna; 18B shows the front-to-rear ratio, and 18C shows the SWR versus frequency.

Fig 18D shows the taper schedule for the 40-meter elements. Note that the wall thickness of the first two sections of tubing is 0.083 inches, rather than 0.058 inches. This element design can survive 93-mph winds with no icing, and 69-mph winds with 1/4 inch of radial ice. The element-to-boom mounting plate for these Yagis is a 0.500-inch thick flat aluminum plate, 6 inches wide by 24 inches long. Electrically each mounting plate is equivalent to a cylinder, with an effective diameter of 4.684 inches. The equivalent length on each side of the boom is 12 inches. These designs require no torque compensator.

**Table 6**  
**Optimized 30-Meter Yagi Designs**

**Two-element 30-meter Yagi, 15-foot boom**

Element	Spacing	Heavy-Duty Tip
File Name		230-150.YAG
Reflector	0.000"	50.250"
Driven Element	174.000"	14.875"

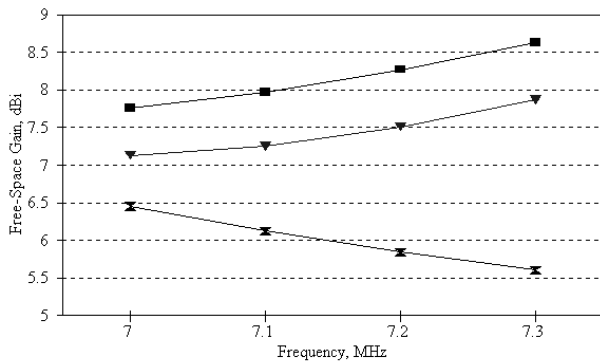
**Three-element 30-meter Yagi, 22-foot boom**

Element	Spacing	Heavy-Duty Tip
File Name		330-22.YAG
Reflector	0.000	59.375
Driven Element	135.000	30.375
Director 1	123.000	19.625

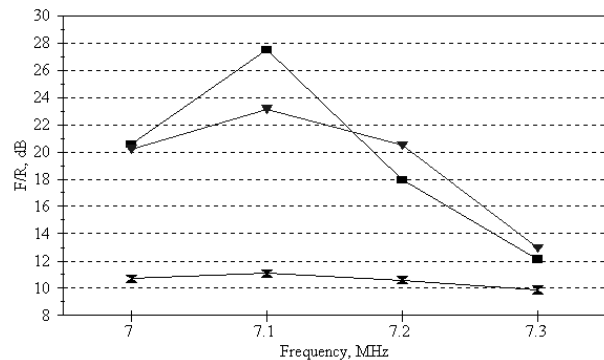
**Three-element 30-meter Yagi, 34-foot boom**

Element	Spacing	Heavy-Duty Tip
File Name		330-34.YAG
Reflector	0.000"	53.750"
Driven Element	212"	26.625"
Director 1	190"	14.500"

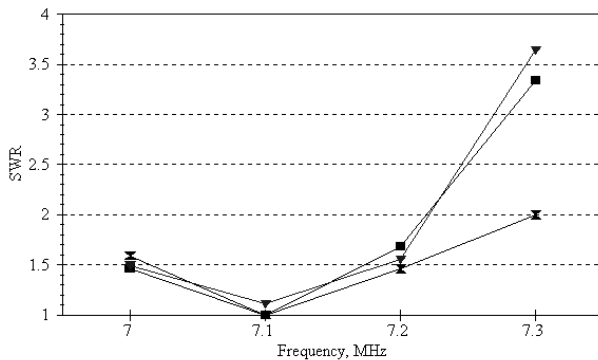
These 30-m Yagi designs are optimized for > 10 dB F/R, and SWR < 2:1 over entire frequency range from 10.100 to 10.150 MHz for heavy-duty elements (105-mph wind survival). Only element tip dimensions are shown. See Fig 17D for element telescoping tubing schedule. All dimensions are in inches. No torque compensator element is required.



(A)

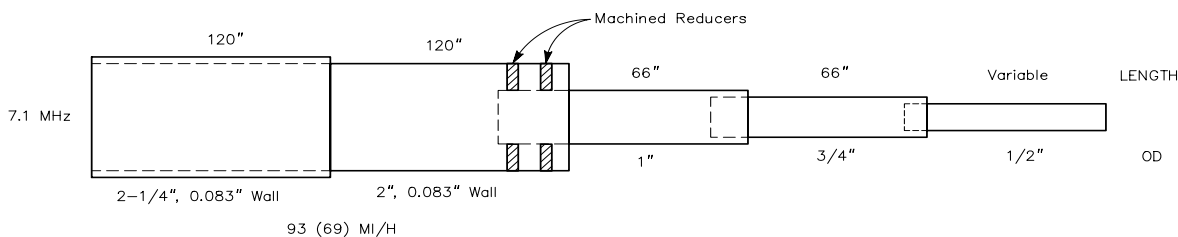


(B)



(C)

**Fig 18—Gain, F/R and SWR performance versus frequency for optimized 40-meter Yagis. At A, gain versus frequency is shown for three 40-meter Yagis whose booms range from 20 feet to 48 feet long, and which have been optimized for better than 10 dB F/R and less than 2:1 SWR over the frequency range from 7.0 to 7.2 MHz. At B, front-to-rear ratio for these antennas is shown versus frequency, and at C, SWR over the frequency range is shown. At D, the taper schedule is shown for heavy-duty 40-meter elements, which can withstand 93-mph winds without icing, and 69-mph winds with 1/4-inch radial ice. Except for the 2 1/4-inch and 2-inch sections, which have 0.083-inch thick walls, the wall thickness for the other telescoping sections of 6061-T6 aluminum tubing is 0.058 inches, and the overlap at telescoping junctions is 3 inches. The 2-inch section utilizes two machined aluminum reducers to accommodate the 1-inch tubing.**



(D)

**Table 7**  
**Optimized 40-Meter Yagi Designs**

Two-element 40-meter Yagi, 20-foot boom		
Element	Spacing	Heavy-Duty Tip
File Name		240-20.YAG
Reflector	0.000"	85.000"
Driven Element	240.000"	25.500"

Three-element 40-meter Yagi, 32-foot boom		
Element	Spacing	Heavy-Duty Tip
File Name		340-32.YAG
Reflector	0.000"	90.750"
Driven Element	196.000"	55.875"
Director 1	182.000"	33.875"

Three-element 40-meter Yagi, 48-foot boom		
Element	Spacing	Heavy-Duty Tip
File Name		340-48.YAG
Reflector	0.000"	79.375"
Driven Element	300.000"	50.625"
Director 1	270.000"	27.500"

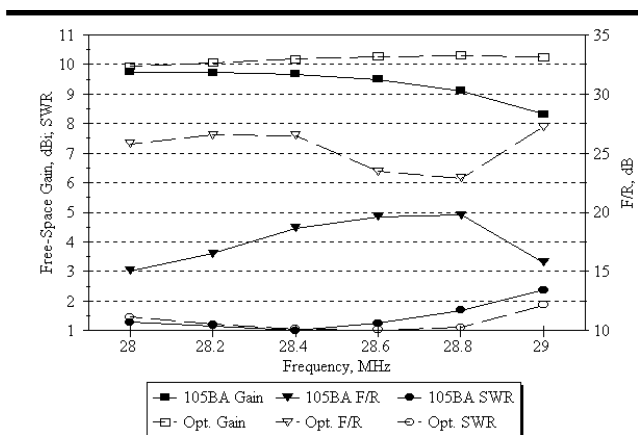
These 40-m Yagi designs are optimized for > 10 dB F/R, and SWR < 2:1 over low-end of frequency range from 7.000 to 7.200 MHz, for heavy-duty elements (95-mph wind survival). Only element tip dimensions are shown. See Fig 18D for element telescoping tubing schedule. All dimensions are in inches. No wind torque compensator is required.

## Modifying Hy-Gain Yagis

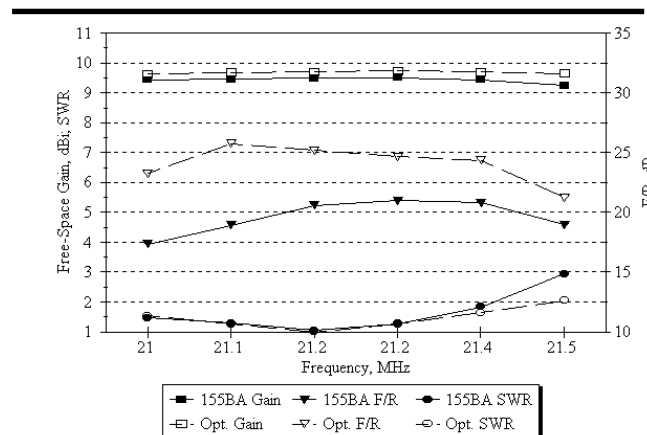
Enterprising amateurs have long used the Telex Communications Hy-Gain “Long John” series of HF monobanders as a source of top-quality aluminum and hardware for customized Yagis. Often-modified older models include the 105BA for 10 meters, the 155BA for 15 meters, and the 204BA and 205BA for 20 meters. Newer Hy-Gain designs, the 105CA, 155CA and 205CA, have been redesigned by computer for better performance.

Hy-Gain antennas have historically had an excellent reputation for superior mechanical design, and Hy-Gain

proudly points out that many of their monobanders are still working after more than 30 years. In the older designs the elements were purposely spaced along the boom to achieve good weight balance at the mast-to-boom bracket, with electrical performance as a secondary goal. Thus, the electrical performance was not necessarily optimum, particularly over an entire amateur band. Newer Hy-Gain designs are electrically superior to the older ones, but because of their strong concern for weight-balance are still not optimal by the definitions used in this chapter.



**Fig 19—Gain, F/R and SWR over the 28.0 to 28.8 MHz range for original and optimized Yagis using Hy-Gain hardware. Original 105BA design provided excellent weight balance at boom-to-mast bracket, but compromised the electrical performance somewhat because of non-optimum spacing of elements. Optimized design requires wind torque-balancing compensator element, and compensating weight at director end of boom to rebalance weight. The F/R ratio over the frequency range for the optimized design is more than 23 dB. Each element uses the original Hy-Gain taper schedule and element-to-boom clamp, but the length of the tip is changed per Table 10.**



**Fig 20—Gain, F/R and SWR over the 21.0 to 21.45 MHz band for original and optimized Yagis using Hy-Gain hardware. Original 155BA design provided excellent weight balance at boom-to-mast bracket, but compromised the electrical performance somewhat because of non-optimum spacing of elements. Optimized design requires wind torque-balancing compensator element, and compensating weight at director end of boom to rebalance weight. The F/R ratio over the frequency range for the optimized design is more than 22 dB. Each element uses the original Hy-Gain taper schedule and element-to-boom clamp, but the length of the tip is changed per Table 9.**

**Table 8**

**Optimized Hy-Gain 20-Meter Yagi Designs**

**Optimized 204BA, Four-element 20-meter Yagi, 26-foot boom**

Element File Name	Spacing	Element Tip BV204CA.YAG
Reflector	0.000"	54.500"
Driven Element	85.000"	52.000"
Director 1	72.000"	61.500"
Director 2	149.000"	50.125"

**Optimized 205CA, Five-element 20-meter Yagi, 34-foot boom**

Element File Name	Spacing	Element Tip BV205CA.YAG
Reflector	0.000"	62.625"
Driven Element	72.000"	53.000"
Director 1	72.000"	63.875"
Director 2	74.000"	61.625"
Director 3	190.000"	55.000"

See CD-ROM file for torque compensator information.

**Table 9**

**Optimized Hy-Gain 15-Meter Yagi Designs**

**Optimized 155BA, Five-element 15-meter Yagi, 24-foot boom**

Element File Name	Spacing	Element Tip BV155CA.YAG
Reflector	0.000"	62.625"
Driven Element	48.000"	64.875"
Director 1	48.000"	63.875"
Director 2	82.750"	61.625"
Director 3	127.250"	55.000"

See CD-ROM file for torque compensator information.

With the addition of wind torque-compensation dummy elements, and with extra lead weights, where necessary, at the director end of the boom for weight-balance, the electrical performance can be enhanced, using the same proven mechanical parts.

Fig 19 shows the computed gain, F/R ratio and SWR for a 24-foot boom, 10-meter optimized Yagi (modified

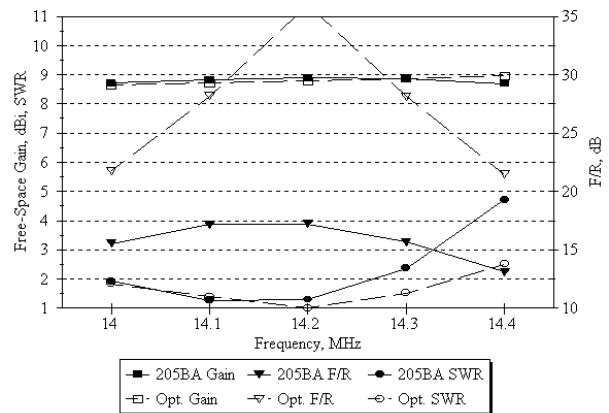
**Table 10**

**Optimized Hy-Gain 10-Meter Yagi Designs**

**Optimized 105BA, Five-element 10-meter Yagi, 24-foot boom**

Element File Name	Spacing, inches	Element Tip BV105CA.YAG
Reflector	0.000"	44.250"
Driven Element	40.000"	53.625"
Director 1	40.000"	52.500"
Director 2	89.500"	50.500"
Director 3	122.250"	44.750"

See CD-ROM file for torque compensator information.



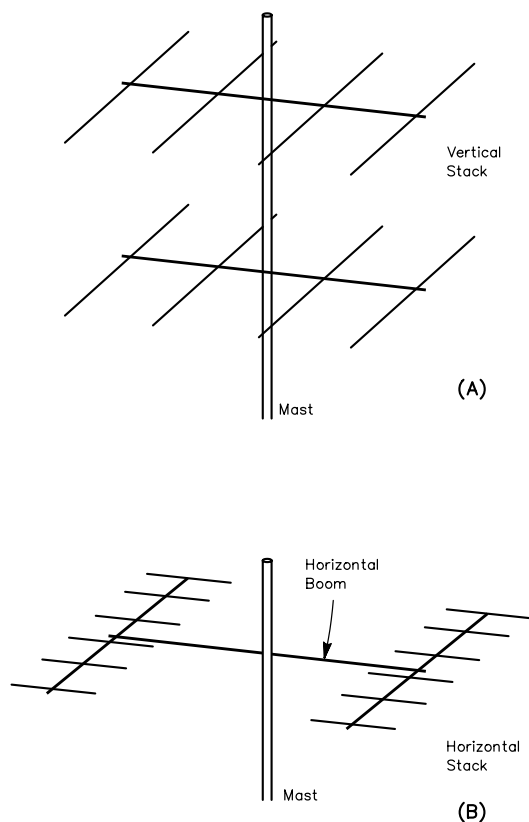
**Fig 21—Gain, F/R and SWR over the 14.0 to 14.35 MHz band for original and optimized Yagis using Hy-Gain hardware. Original 205BA design provided good weight balance at boom-to-mast bracket, but compromised the electrical performance because of non-optimum spacing of elements. Optimized design requires a wind torque-balancing compensator element, and compensating weight at director end of boom to rebalance weight. The F/R ratio over the frequency range for the optimized design is more than 23 dB, while the original design never went beyond 17 dB of F/R. Each element uses the original Hy-Gain taper schedule and element-to-boom clamp, but the length of the tip is changed per Table 8.**

105BA) using Hy-Gain hardware. Fig 20 shows the same for a 26-foot boom 15-meter Yagi (modified 155BA), and Fig 21 shows the same for a 34-foot boom (modified 205BA) 20-meter Yagi. Tables 8 through 10 show dimensions for these designs. The original Hy-Gain taper schedule is used for each element. Only the length of the end tip (and the spacing along the boom) is changed for each element.

## Stacked Yagis

Parasitic arrays are commonly stacked either in broadside or collinear fashion to produce additional directivity and gain. In HF amateur work, the most common broadside stack is a vertical stack of identical Yagis on a single tower. This arrangement is commonly called a vertical stack. At VHF and UHF, amateurs often employ collinear stacks,

where identical Yagis are stacked side-by-side at the same height. This arrangement is called a horizontal stack, and is not usually found at HF, because of the severe mechanical difficulties involved with large, rotatable side-by-side arrays. Fig 22 illustrates the two different stacking arrangements. In either case, the individual Yagis making up the stack are



**Fig 22—Stacking arrangements. At A, two Yagis are stacked vertically (broadside) on the same mast. At B, two Yagis are stacked horizontally (collinear) side-by-side. At HF the vertical stack is more common because of mechanical difficulties involved with large HF antennas stacked side-by-side, whereas at VHF and UHF the horizontal stack is common.**

generally fed in phase. There are times, however, when individual antennas in a stacked array are fed out of phase in order to emphasize a particular elevation pattern. See Fig 4 in Chapter 17 for such a case where elevation pattern steering is implemented for a repeater station.

The following material on stacking Yagis has been condensed from an article in February 1994 *QST* by R. Dean Straw, N6BV, and Fred Hopengarten, K1VR, where they described their two different stacks of triband Yagis.

### STACKS AND WIDE ELEVATION FOOTPRINTS

Detailed studies using sophisticated computer models of the ionosphere have revealed that coverage of a wide range of elevation angles is necessary to ensure consistent DX or contest coverage on the HF bands. These studies have been conducted over all phases of the 11-year solar cycle, and for numerous transmitting and receiving QTHs throughout the world. Table 11 is an example of such a study using a program called *IONCAP* for the path from New England to

both Western and Eastern Europe. It lists the statistical range of elevation angles covering 100% of the time that signals arrive. This is for the whole 11-year solar cycle. Different tables are required to describe paths from New England to other parts of the world, and to describe the paths from other transmitting sites to various parts of the world. [See Chapter 23, “Radio Wave Propagation,” for additional elevation angle information for other parts of the world.]

Fig 23 shows the computed elevation response for various combinations of Hy-Gain TH7DX triband Yagis on 10 meters, calculated using a version of the *MININEC* computer program. The highest curve is for a stack of three TH7DXs at heights of 90, 60 and 30 feet, placed on one tower above flat ground with an average conductivity and dielectric constant. Overlaid on the same graph are the elevation patterns for a single TH7DX at 70 feet, representing a fairly common station setup. Also shown is the pattern for a single TH7DX at 40 feet, the pattern for a stack of two TH7DX tribanders at 70 feet and 40 feet on one tower and the pattern for a single 90-foot high dipole.

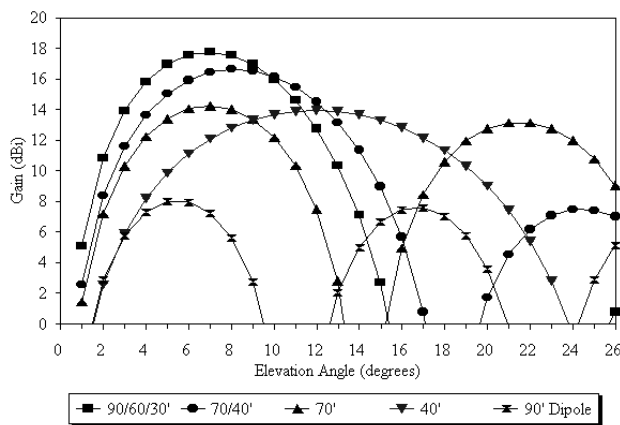
At 10 meters, the stack of three triband Yagis at 90, 60 and 30 feet has good coverage for low elevation angles, and good coverage out to about 11° elevation, where its pattern crosses that of the single 40-foot-high antenna. At an elevation of 2°, the stack of three has 8 dB more gain than the single 40-foot-high antenna, but only 2 dB of gain over the stack of two antennas at 70 and 40 feet. For the range of angles needed to cover Western and Eastern Europe, the race between the stack of three and the shorter stack of two is pretty close. A single TH7DX on 10 meters at 90 feet suffers dramatically whenever the elevation angles are higher than approximately 9°, as commonly occurs into Western Europe during the strongest part of the 10-meter opening from New England.

Both of the stacks illustrated here give a wider *elevation footprint* than any single antenna, so that all the angles can be covered automatically without having to switch from higher to lower antennas manually. This is perhaps the major benefit of using stacks, but not the only one.

Fig 24 compares the 15-meter elevation responses for tribanders at the same heights as for 10 meters. Here, the best system is also the stack of three at 90, 60 and 30 feet, followed by the stack of two at 70 and 40 feet. For most of

**Table 11  
Range of Elevation Angles from New England to Europe**

Band	Elevation Angles for Western Europe	Elevation Angles for Eastern Europe
80 meters	3° - 21°	1° - 33°
40 meters	1° - 22°	1° - 30°
20 meters	3° - 19°	1° - 28°
15 meters	2° - 19°	1° - 28°
10 meters	1° - 15°	1° - 18°



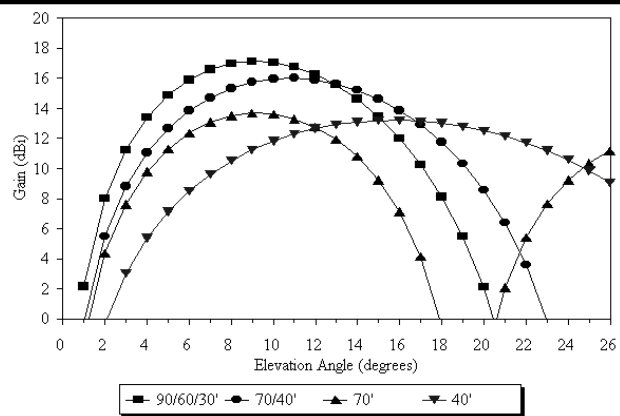
**Fig 23—Comparison of elevation patterns for 10-meter TH7DX tribander combinations mounted over flat ground. The 10-meter stack of three at 90, 60 and 30 feet has an elevation footprint between 3.5° to 11° at its half-power points, and a peak gain of 17.8 dBi. The stack at 70 and 40 feet has a peak gain of 16.7 dBi at 8°, with coverage from 4° to 12.5° at its half-power points. A dipole at 90 feet might seem like a practical reference antenna for the stack of three Yagis. At 7° elevation, the 17.8 dBi gain of the stack of three is almost 10 dB greater than the gain of the 90-foot dipole. However, at 11°, where the dipole is in a null, the 14.6 dBi gain of the three-stack is 32 dB stronger than the dipole—this would be a gain of 32 dB! Clearly, it is difficult to measure a stack of Yagis directly against a single dipole. It would be fair, however, to use a stack of dipoles for comparison, or to compare the stack's gain to a free-space dipole. By definition, the use of dBi compares the stack's gain to that of a single free-space isotropic radiator.**

the time, the single Yagi at 70 feet is down from the stacks by at least 3 dB. The stack of three at an elevation of 8° has a gain of about 7 dB over the single tribander at 40 feet. Again, either 15-meter stack gives a wider elevation footprint than any single antenna does.

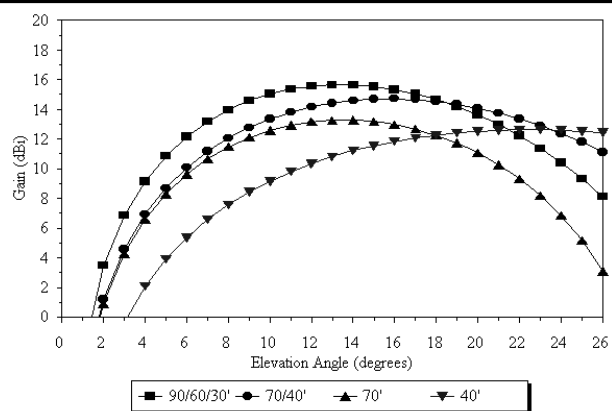
**Fig 25** shows the 20-meter elevation response for the same triband antennas. The edge in favor of the bigger stack narrows somewhat compared to the other antennas, mainly because the 30-foot spacing ( $0.43 \lambda$ ) between antennas in the stack is more of a compromise for gain on 20 meters than for the upper bands. However, the stack of three still gives a gain of 6 dB over the single 40-foot-high tribander at a 10° elevation angle, and has a wider elevation footprint than any single antenna.

### STACKS AND COMPRESSION OF THE FORWARD AND REARWARD ELEVATION LOBES

The basic principle of a stacked array is that it concentrates energy from higher angle lobes (which don't contribute much to communications anyway) into the main elevation lobe. The stack squeezes down the main elevation lobe, while maintaining the frontal lobe azimuth pattern of



**Fig 24—Comparison of elevation patterns for 15-meter TH7DX tribander combinations mounted over flat ground. The stack at 90, 60 and 30 feet yields an excellent footprint over the range of 4° to 14° at its half-power points, with a peak gain of 17.1 dBi. The stack at 70 and 40 feet has a peak gain of 16.0 dBi at 11°, with coverage from 5° to 17° at its half-power points. Like the 10-meter stack of three, the stack of two TH7DXs is very close in overall performance, except for lower gain at very low angles, where the higher top antenna comes into play in the stack of three.**



**Fig 25—Comparison of elevation patterns for 20-meter TH7DX tribander combinations. The peak gain for the 90, 60 and 30-foot stack is 15.7 dBi at 13° elevation. The 3 dB elevation coverage is from 6.5° to 21.5°. The peak gain for the stack of two at 70 and 40 feet is 14.7 dBi at 16°, and the 3-dB elevation coverage is from 7.5° to 25°. The stack of three has proven to be an extremely effective antenna.**

a single Yagi. This is the reason why many state-of-the-art contest stations are stacking arrays of relatively short-boom antennas, rather than stacking long-boom, higher-gain Yagis. A long-boom HF Yagi narrows both the azimuthal pattern and the elevation pattern, making pointing of the antenna more critical, and making it more difficult to spread a signal over a wide azimuthal area, such as all of Europe and Asiatic Russia at one time.

The compression of the higher angle lobes has another desirable effect, beyond that of creating more gain. It reduces

QRM from high-angle signals arriving from the direction in which the antenna is pointed, and from high-angle signals coming from other directions, such as local QRM. A stack also squeezes down the elevation response of the rearward lobe, just like the forward lobe. On the negative side, however, the front-to-rear ratio of a stack is often degraded compared to that of a single, optimized Yagi, although this is not usually a severe problem.

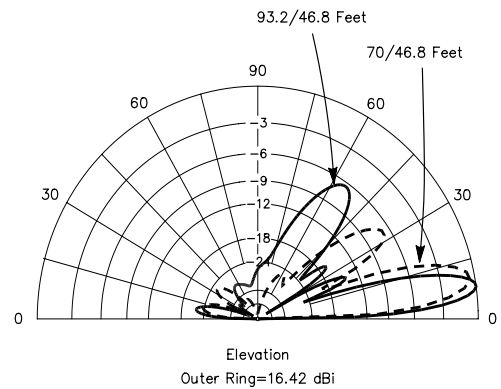
By definition, a stack of triband Yagis has a constant vertical spacing between antennas in terms of feet or meters, but not in terms of wavelength. There is a great deal of folklore and superstition among amateurs about stacking distances. *There is nothing magical about stacking distances for practical HF Yagis.* The gain gradually increases as spacing in terms of wavelength is increased between individual Yagis in a stack, and then decreases slowly once the spacing is greater than about  $1.0 \lambda$ . The difference in gain between spacings of  $0.5 \lambda$  and  $1.0 \lambda$  for a stack of TH7DX Yagis amounts to only a fraction of a decibel. Furthermore, the main constraint that limits choice of stacking distances between Yagis is the spacing between guy wire sets on the tower itself.

Fig 26 shows the elevation patterns for two 15-meter TH7DXs stacked at 70 and 46.8 feet (a half-wavelength spacing on 15 meters), and at 93.2 and 46.8 feet (one-wavelength spacing). The elevation footprint for the higher stack has slightly more gain at lower angles, as expected, and the peak gain is just slightly higher, but the stack with the smaller spacing still has good gain and a desirable pattern. The situation is different on VHF, where truly long-boom, high-gain designs are practical and desirable, and where stack spacing is correspondingly more critical because of complex mutual coupling and interaction between the antennas.

You will note that the stack in Fig 26 at 93.2 and 46.8 feet has a rather nasty looking high-angle lobe peaking around  $55^\circ$ . While a high-angle lobe like this does look rather ominous, the fact is that signals on the upper HF bands (where stacking is commonly employed) rarely arrive at such high incoming angles. In fact, incoming angles are predominantly less than  $30^\circ$ —this includes both desired signals and undesired interfering signals. Look again at the incoming angles in Table 11. Concern about such high-angle lobes is not really warranted in practice.

### STACKS AND FADING

Both K1VR and N6BV have solicited a number of reports from stations, mainly in Europe, to compare various combinations of antennas in stacks and as single antennas. The peak gain of the stack is usually just a little bit higher than that for the best of the single antennas, which is not surprising. Even a large stack has no more than about 6 dB of gain over a single Yagi at a height favoring the prevailing elevation angle. Fading on the European path can easily be 20 dB or more, so it is very confusing to try to make definitive comparisons. They have noticed over many tests that the stacks are much less susceptible to fading compared to single Yagis. Even within the confines of a typical SSB



**Fig 26—The effect of stacking distance on elevation patterns for 15-meter TH7DXs. The stack at 93.2 and 46.8 feet (one wavelength spacing) has a lower peak elevation angle (because of the top antenna's height) and just slightly more stacking gain than does the stack at 70 and 46.8 feet. The exact distance between practical HF Yagis is not critical to obtain the benefits of stacking. For a stack of tribanders at 90, 60 and 30 feet, the distance in wavelengths between individual antennas is  $0.87 \lambda$  at 28.5 MHz,  $0.65 \lambda$  at 21.2 MHz, and  $0.43 \lambda$  at 14.2 MHz.**

bandwidth, frequency-selective fading occasionally causes the tonal quality of a voice to change on both receive and transmit, often dramatically becoming fuller on the stacks, and tinnier on the single antennas. This doesn't happen all the time, but is often seen. They have also observed often that the depth of a fade is less, and the period of fading is longer, on the stacks compared to single antennas.

Exactly *why* stacks exhibit less fading is a fascinating subject, for which there exist a number of speculative ideas, but little hard evidence. Some maintain that stacks outperform single antennas because they can afford *space diversity* effects, where by virtue of the difference in physical placement one antenna will randomly pick up signals that another one in another physical location might not hear.

This is difficult to argue with, and equally difficult to prove scientifically. A more plausible explanation about why stacked Yagis exhibit superior fading performance is that their narrower frontal elevation lobes can discriminate against undesired propagation modes. Even when band conditions favor, for example, a very low  $3^\circ$  elevation angle on 10 or 15 meters from New England to Western Europe, there are signals, albeit weaker ones, that arrive at higher elevation angles. These higher-angle signals have traveled longer distances on their journey through the ionosphere, and thus their signal levels and their phase angles are different from the signals traversing the primary propagation mode. When combined with the dominant mode, the net effect is that there is both destructive and constructive fading. If the elevation response of a stacked antenna can discriminate against signals arriving at higher elevation angles, then in theory the fading will be reduced.

## STACKS AND PRECIPITATION STATIC

The top antenna in a stack is often much more affected by rain or snow precipitation static than is the lower antenna. N6BV and K1VR have observed this phenomenon, where signals on the lower antenna by itself are perfectly readable, while S9+ rain static is rendering reception impossible on the higher antenna or on the stack. This means that the ability to select individual antennas in a stack can sometimes be extremely important.

## STACKS AND AZIMUTHAL DIVERSITY

*Azimuthal diversity* is a term coined to describe the situation where one of the antennas in a stack is purposely pointed in a direction different from the main direction of the stack. During most of the time in a DX contest from the East Coast, the lower antennas in a stack are pointed into Europe, while the top antenna is often rotated toward the Caribbean or Japan. In a stack of three identical Yagis, the first-order effect of pointing one antenna in a different direction is that one-third of the transmitter power is diverted from the main target area. This means that the peak gain is reduced by 1.8 dB, not a very large amount considering that signals are often 10 to 20 dB over S9 anyway when the band is open from New England to Europe.

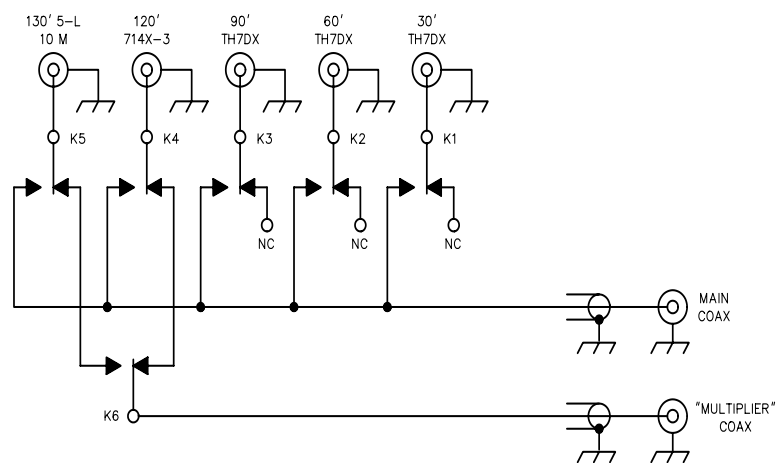
## THE N6BV/1 ANTENNA SYSTEM— BRUTE FORCE FEEDING

The N6BV/1 system in Windham, New Hampshire, was located on the crest of a small hill about 40 miles from Boston, and could be characterized as a good, but not dominant, contesting station. A number of top-10 contest results were achieved from that station in the 1990s before N6BV returned to California.

There was a single 120-foot high Rohn 45 tower, guyed at 30-foot intervals, with a 100-foot horizontal spread from tower base to each guy point so there was sufficient room for rotation of individual Yagis on the tower. Each set of guy wires employed heavy-duty insulators at 57-foot intervals, to avoid resonances in the 80 through 10-meter amateur bands. There were five Yagis on the tower. A heavy-duty 12-foot long steel mast with 0.25-inch walls was at the top of the tower, turned by an Orion 2800 rotator. Two thrust bearings were used above the rotator, one at the top plate of the tower itself, and the other about 2 feet down in the tower on a modified rotator shelf plate. The two thrust bearings allowed the rotator to be removed for service.

At the top of the mast, 130 feet high, was a 5-element, computer-optimized 10-meter Yagi, which was a modified Create design on a 24-foot boom. The element tuning was modified from the stock antenna in order to achieve higher gain and a better pattern over the band. At the top of the tower (120-foot level) was mounted a Create 714X-3 triband Yagi. This was a large tribander, with a 32-foot boom and five elements. Three elements were active on 40 meters, four were active on 20 meters and four were active on 15 meters. The 40-meter elements were loaded with coils, traps and capacitance hats, and were approximately 46 feet long. A triband 20/15/10-meter Hy-Gain TH7DX tribander was fixed into Europe at the 90-foot level on the tower, just above the third set of guys.

At the 60-foot level on the tower, just above the second set of guys, there was a “swinging-gate” side-mount bracket, made by DX Engineering of Oregon. A Hy-Gain *Tailtwister* rotator turned a TH7DX on this side mount. (Note that both the side mount and the element spacings of the TH7DX itself



**Fig 27—N6BV/1 switch-box system.** This uses a modified DX Engineering remote switch box, with relay K6 added to allow selection of either of the two top antennas (5-element 10-meter Yagi or 40/20/ 15-meter triband 714X-3) as a “multiplier” antenna. There is no special provision for SWR equalization when any or all of the Yagis are connected in parallel as a stack fed by the Main coaxial cable. Each of the five Yagis is fed with equal lengths of flexible Belden 9913 coax, so phasing can be maintained on any band. The Main and “Multiplier” coaxes going to the shack are 0.75 inch OD 75-Ω Hardline cables.



prevented full rotation around the tower—about 280° of rotation was achieved with this system.) At the 30-foot level, just above the first set of guys, was located the third TH7DX, also fixed on Europe.

All five Yagis were fed with equal lengths of Belden 9913 low-loss coaxial cable, each measured with a noise bridge to ensure equal electrical characteristics. At each feed point a ferrite-bead choke balun (using seven large beads) was placed on the coax. All five coaxial cables went to a relay switch box mounted at the 85-foot level on the tower. Fig 27 shows the schematic for the switch box, which was fed with 250 feet of 75-Ω, 0.75-inch OD Hardline coaxial cable.

The stock DX Engineering remote switch box was modified by adding relay K6, so that either the 130-foot or the 120-foot rotating antenna could be selected through a second length of 0.75-inch Hardline going to the shack. This created a *Multiplier* antenna, independent of the *Main* antennas. A second band could be monitored in this fashion while calling CQ using the main antennas on another band. Band-pass filters were required at the multiplier receiver to prevent overload from the main transmitter.

The 0.75-inch Hardline had very low losses, even when presented with a significant amount of SWR at the switch-box end. This was important, because unlike K1VR's system, no attempt was made at N6BV to maintain a constant SWR when relays K1 through K5 were switched in or out. This seemingly cavalier attitude came about because of several factors. First, there were many different combinations of antennas that could be used together in this system. Each relay coil was independently controlled by a toggle switch in the shack. N6BV was unable to devise a matching system that did not become incredibly complex because of the numerous impedance combinations used over all the five bands.

Second, the worst-case additional transmission line loss due to a 4:1 SWR mismatch when four antennas were connected in parallel on 10 meters was only 0.5 dB. It was true that the linear amplifier had to be retuned slightly when combinations of antennas were switched in and out, but this was a small penalty to pay for the reduced complexity of the switching and matching networks. The 90/60/30-foot stack into Europe was used for about 95% of the time during DX contests, so the small amount of amplifier retuning for other antenna combinations was considered only a minor irritation.

### WHY TRIBANDERS?

Without a doubt, the most common question K1VR and N6BV were asked is: "Why did you pick *tribanders* for your stacks?" Triband antennas were chosen with full recognition that they are compromise antennas. Other enterprising amateurs have built stacked tribander arrays. Bob Mitchell, N5RM, is a prominent example, with his so-called *TH28DX* array of four TH7DX tribanders on a 145-foot-high rotating tower. Mitchell employed a rather complex system of relay-selected tuned networks to choose either the upper stacked pair, the lower stacked pair or all four antennas in stack. Others in Texas have also had good results with their tribander stacks. Contester Danny Eskenazi, K7SS, has very successfully used

a pair of stacked KT-34XA tribanders for years.

A major reason why tribanders were used is that over the years both authors have had good results using TH6DXX or TH7DX antennas. They are ruggedly built, mechanically and electrically. They are able to withstand New England winters without a whimper, and their 24-foot long booms are long enough to produce significant gain, despite trap-loss compromises. Amateurs speculating about trap losses in tribanders freely bandy about numbers between 0.5 and 2 dB. Both N6BV and K1VR are comfortable with the lower figure, as are the Hy-Gain engineers.

Consider this: If 1500 W of transmitter power is going into an antenna, a loss of 0.5 dB amounts to 163 W. This would create a significant amount of heat in the six traps that are on average in use on a TH6DXX, amounting to 27 W per trap. If the loss were as high as 1 dB, this would be 300 W total, or 50 W per trap. Common sense says that if the overall loss were greater than about 0.5 dB, the traps would act more like big *firecrackers* than resonant circuits! A long-boom tribander like the TH6DXX or TH7DX also has enough space to employ elements dedicated to different bands, so the compromises in element spacing usually found on short-boom 3 or 4-element tribanders can be avoided.

Another factor in the conscious choice of tribanders was first-hand frustration with the serious interaction that can result from stacking monoband antennas closely together on one mast in a Christmas Tree configuration. N6BV's worst experience was with the ambitious 10 through 40-meter Christmas Tree at W6OWQ in the early 1980s. This installation used a Tri-Ex SkyNeedle tubular crankup tower with a rotating 10-foot-long heavy-wall mast. The antenna suffering the greatest degradation was the 5-element 15-meter Yagi, sandwiched 5 feet below the 5-element 10-meter Yagi at the top of the mast, and 5 feet above the full-sized 3-element 40-meter Yagi, which also had five 20-meter elements interlaced on its 50-foot boom.

The front-to-back ratio on 15 meters was at best about 12 dB, down from the 25+ dB measured with the bottom 40/20-meter Yagi removed. No amount of fiddling with element spacing, element tuning or even orientation of the 15-meter boom with respect to the other booms (at 90° or 180°, for example) improved its performance. Further, the 20-meter elements had to be lengthened by almost a foot *on each end of each element* in order to compensate for the effect of the interlaced 40-meter elements. It was a lucky thing that the tower was a motorized crankup, because it went up and down hundreds of times as various experiments were attempted!

Interaction due to close proximity to other antennas in a short Christmas Tree can definitely destroy carefully optimized patterns of individual Yagis. Nowadays, such interaction can be modeled using a computer program such as *EZNEC* or *NEC*. A gain reduction of as much as 2 to 3 dB can easily result due to close vertical spacing of monobanders, compared to the gain of a single monoband antenna mounted in the clear. Curiously enough, at times such a reduction in gain can be found even when the front-

to-back ratio is not drastically degraded, or when the front-to-back occasionally is actually *improved*.

Dave Leeson, W6NL (ex-W6QHS), mentions that the 10-meter Yagi in his closely stacked Christmas Tree (15 meters at the top, 10 meters in the middle, and 20 meters at the bottom of the rotating mast) loses “substantial gain” because of serious interaction with the 20-meter antenna. (We calculated that the free-space gain in the W6NL stack drops to 5 dBi, compared to about 9 dBi with no surrounding antennas.) Monobanders are *definitely not* universally superior to tribanders in multiband installations! In private conversations, W6NL has indicated that he would not repeat this kind of short Christmas Tree installation again.

If you plan on stacking monoband Yagis—for example, putting only 15-meters Yagis on a single tower, with your other monoband stacks on other towers—do make sure you model the system to see if any interactions occur.

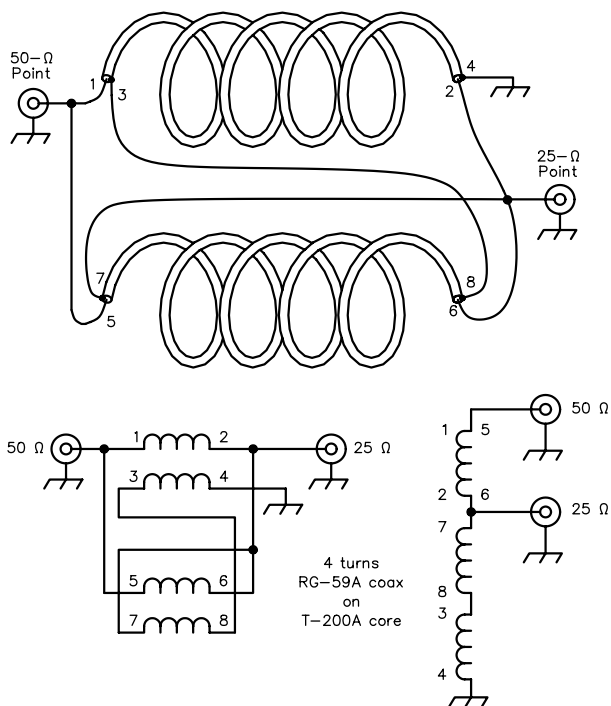
Finally, in the N6BV/1 installation, triband antennas were chosen because the system was meant to be as simple as possible, given a certain desired level of performance, of course. Triband antennas make for less mechanical complexity than do an equivalent number of monobanders. There were five Yagis on the N6BV/1 tower, yielding gain from 40 to 10 meters, as opposed to using 12 or 13 monobanders on the tower.

### THE K1VR ARRAY: A MORE ELEGANT APPROACH TO MATCHING

The K1VR stacked array is on a 100-foot high Rohn 25 tower, with sets of guy wires at 30, 60 and 90 feet, made of nonconducting Phillystran. Phillystran is a nonmetallic Kevlar rope covered by black polyethylene to protect against the harmful effects of the sun’s ultraviolet rays. A caution about Phillystran: Don’t allow tree branches to rub against it. It is designed to work in tension, but unlike steel guy wire, it does not tolerate abrasion well.

Both antennas are Hy-Gain TH6DXX tribanders, with the top one at 97 feet and the bottom one at 61 feet. The lower antenna is rotated by a Telex Ham-M rotator on a homemade swinging-gate side mount, which allows it to be rotated 300° around the tower without hitting any guy wires or having an element swing into the tower. At the 90-foot point on the tower, a 2-element 40-meter Cushcraft Yagi has been mounted on a RingRotor so it can be rotated 360° around the tower.

After several fruitless attempts trying to match the TH6DXX antennas so that either could be used by itself or together in a stack, K1VR settled on using a relay-selected broadband toroidal matching transformer. When both triband antennas are fed together in parallel as a stack, it transforms the resulting 25-Ω impedance to 50 Ω. The transformer is wound on a T-200-A powdered-iron core, available from Amidon, Palomar Engineering or Ocean State Electronics. Two lengths of twin RG-59 coax (sometimes called Siamese or WangNet), four turns each, are wound on the core. Two separate RG-59 cables could be used, but the Siamese-twin cable makes the assembly look much more tidy. The shields

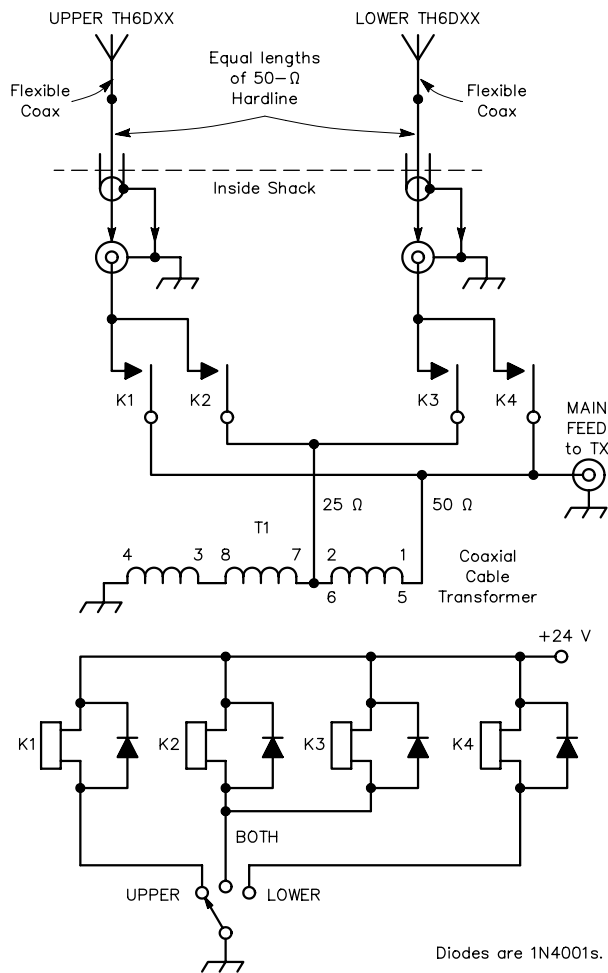


**Fig 28—Diagram for matching transformer for K1VR stacked tribander system. The core is powdered-iron core T-200A, with four turns of two RG-59A or “Siamese” coax cables. Center conductors are connected in parallel and shields are connected in series to yield 0.667:1 turns ratio, close to desired 25 to 50-Ω transformation.**

of the RG-59 cables are connected in series, and the center conductors are connected in parallel. See Fig 28 for details.

Fig 29 shows the schematic of the K1VR switch box, which is located in the shack. Equal electrical lengths of 50-W Hardline are brought from the antennas into the shack and then to the switch box. Inside the box, the relay contacts were soldered directly to the SO-239 chassis connectors to keep the wire lengths down to the absolute minimum. K1VR used a metal box which was larger than might appear necessary because he wanted to mount the toroidal transformer with plenty of clearance between it and the box walls. The toroid is held in place with a piece of insulation foam board. Before placing the switch box in service, the system was tested using two 50-Ω dummy loads, with equal lengths of cable connected in parallel to yield 25 Ω. The maximum SWR measured was 1.25:1 at 14 MHz, 1.3:1 at 21 MHz and 1.15:1 at 28 MHz, and the core remained cold with 80 W of continuous output power.

One key to the system performance is that K1VR made the electrical lengths of the two hardlines the same (within 1 inch) by using a borrowed TDR (time domain reflectometer). Almost as good as Hardline, K1VR points out, would be to cut exactly the same length of cable from the same 500-foot roll of RG-213. This eliminates manufacturing tolerances between different rolls of cable.

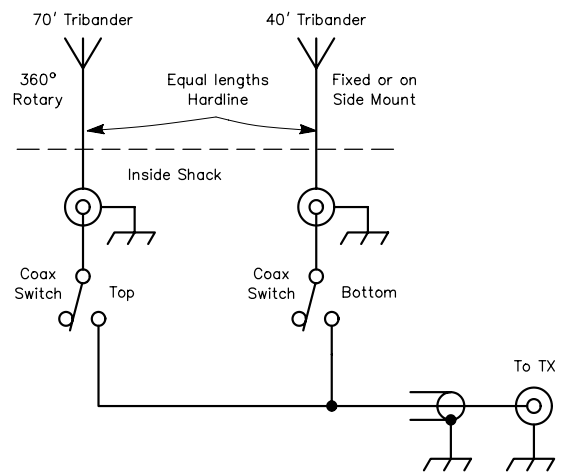


**Fig 29—Relay switch box for K1VR stacked tribander system. Equal lengths of 50-Ω Hardline (with equal lengths of flexible 50-Ω cable at each antenna to allow rotation) go to the switch box in the shack. The SWR on all three bands for Upper, Lower or Both switch positions is very close to constant.**

K1VR's experience over the last 10 years has been that at the beginning of the 10 or 15-meter morning opening to Europe the upper antenna is better. Once the band is wide open, both antennas are fed in phase to cast a bigger shadow, or footprint, on Europe. By mid-morning, the lower antenna is better for most Europeans, although he continues to use the stack in case someone is hearing him over a really long distance path throughout Europe. He reports that it is always very pleasant to be called by a 4S7 or HS0 or VU2 when he is working Europeans at a fast clip!

### SOME SUGGESTIONS FOR STACKING TRIBANDERS

It is unlikely that many amateurs will try to duplicate exactly K1VR's or N6BV's contest setups. However, many



**Fig 30—Simple feed system for 70/40-foot stack of tribanders. Each tribander is fed with equal lengths of 0.5-inch 75-Ω Hardline cables (with equal lengths of flexible coax at the antennas to allow rotation), and can be selected singly or in parallel at the operator's position in the shack. Again, no special provision is made in this system to equalize SWR for any of the combinations.**

hams already have a tribander on top of a moderately tall tower, typically at a height of about 70 feet. It is not terribly difficult to add another, identical tribander at about the 40-foot level on such a tower. The second tribander can be pointed in a fixed direction of particular interest (such as Europe or Japan), or it can be rotated around the tower on a side mount or a Ring Rotor. If guy wires get in the way of rotation, the antenna can usually be arranged so that it is fixed in a single direction.

Insulate the guy wires at intervals to ensure that they don't shroud the lower antenna electrically. A simple feed system consists of equal-length runs of surplus 0.5-inch 75-Ω Hardline (or more expensive 50-Ω Hardline, if you are really obsessed by SWR) from the shack up the tower to each antenna. Each tribander is connected to its respective Hardline feeder by means of an equal length of flexible coaxial cable, with a ferrite choke balun, so that the antenna can be rotated.

Down in the shack, the two hardlines can simply be switched in and out of parallel to select the upper antenna only, the lower antenna only, or the two antennas as a stack. See Fig 30. Any impedance differences can be handled as stated previously, simply by retuning the linear amplifier, or by means of the internal antenna tuner (included in most modern transceivers) when the transceiver is run barefoot. The extra performance experienced in such a system will be far greater than the extra decibel or two that modeling calculates.

# Chapter 12

# Quad Arrays

Chapter 11, HF Yagi Arrays, discussed Yagi arrays as systems of approximately half-wave dipole elements that are coupled together mutually. You can also employ other kinds of elements using the same basic principles of analysis. For example, loops of various types may be combined into directive arrays. A popular type of parasitic array using loops is the *quad antenna*, in which loops having a perimeter of about one wavelength are used in much the same way as half-wave dipole elements in the Yagi antenna.

Clarence Moore, W9LZX, created the quad antenna in the early 1940s while he was at the Missionary Radio Station HCJB in Quito, Ecuador. He developed the quad to combat the effects of corona discharge at high altitudes. The problem at HCJB was that their large Yagi was literally destroying itself by melting its own element tips. This occurred due to the huge balls of corona it generated in the thin atmosphere of the high Andes mountains. Moore reasoned correctly that closed loop elements would generate less high voltage—and hence less corona—than would the high impedances at the ends of a half-wave dipole elements.

Fig 1 shows the original version of the two-element quad, with a driven element and a parasitic reflector. The square loops may be mounted either with the corners lying on horizontal and vertical lines, as shown at the left, or with two sides horizontal and two vertical (right). The feed points shown for these two cases will result in horizontal polarization, which is commonly used.

Since its inception, there has been controversy whether the quad is a better performer than a Yagi. Chapter 11 showed that the three main electrical performance parameters of a Yagi are gain, response patterns (front-to-rear ratio, F/R) and drive impedance/SWR. Proper analysis of a quad also involves checking all these parameters across the entire frequency range over which you intend to use it. Both a quad and a Yagi are classified as “parasitic, end-fire arrays.” Modern antenna modeling by computer shows that monoband Yagis and quads with the same boom lengths and optimized for the same performance parameters have gains within about 1 dB of each other, with the quad slightly ahead of the Yagi.

Fig 2 plots the three parameters of gain, front-to-rear ratio (F/R) and SWR over the 14.0 to 14.35-MHz band for

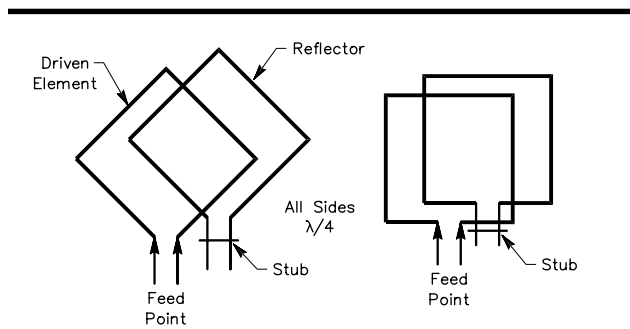


Fig 1—The basic two-element quad antenna, with driven-element loop and reflector loop. The driven loops are electrically one wavelength in circumference ( $\frac{1}{4}$  wavelength on a side); the reflectors are slightly longer. Both configurations shown give horizontal polarization. For vertical polarization, the driven element should be fed at one of the side corners in the arrangement at the left, or at the center of a vertical side in the “square” quad at the right.

20-M Optimized Monoband Quad vs Yagi  
3-Ele. Quad/4-Ele. Yagi, 26' Booms

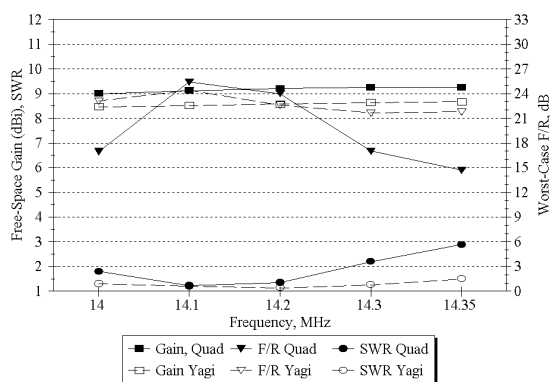


Fig 2—Comparison of gain, F/R and SWR over the 14.0 to 14.35-MHz range for an optimized three-element quad and an optimized three-element Yagi, both on 26-foot booms. The quad exhibits almost 0.5 dB more gain for the same boom length, but doesn’t have as good a rearward pattern over the whole frequency range compared to the Yagi. This is evidenced by the F/R curve. The quad’s SWR curve is also not quite as flat as the Yagi. The quad’s design emphasizes gain more than the other two parameters.

two representative antennas—a monoband three-element quad and a monoband four-element Yagi. Both of these have 26-foot booms and both are optimized for the best compromise of gain, F/R and SWR across the whole band.

While the quad in Fig 2 consistently exhibits about 0.5 dB more gain over the whole band, its F/R pattern toward the rear isn't quite as good as the Yagi's over that span of frequencies. This quad attains a maximum F/R of 25 dB at 14.1 MHz, but it falls to 17 dB at the bottom end of the band and 15 dB at the top. On the other hand, the Yagi's F/R stays consistently above 21 dB across the whole 20-meter band. The quad's SWR rises to just under 3:1 at the top end of the band, but stays below 2:1 from 14.0 to almost 14.3 MHz. The Yagi's SWR remains lower than 1.5:1 over the whole band.

The reason the Yagi in Fig 2 has more consistent responses for gain, F/R and SWR across the whole 20-meter band is that it has an additional parasitic element, giving two additional variables to play with—that is, the length of that additional element and the spacing of that element from the others on the boom.

Yagi advocates point out that it is easier to add extra elements to a Yagi, given the mechanical complexities of adding another element to a quad. Extra parasitic elements give a designer more flexibility to tailor all performance parameters over a wide frequency range. Quad designers have historically opted to optimize strictly for gain and, as stated before, they can achieve as much as 1 dB more gain than a Yagi with the same length boom. But in so doing, a quad designer typically has to settle for front-to-rear patterns that are peaked over more narrow frequency ranges. The 20-meter quad plots in Fig 2 actually represent an even-handed approach, where the gain is compromised slightly to obtain a more consistent pattern and SWR across the whole band.

Fig 3 plots gain, F/R and SWR for two 10-meter monoband designs: a five-element quad and a five-element Yagi, both placed on 26-foot booms. The quad now has the same degrees of freedom as the Yagi, and as a consequence the pattern and SWR are more consistent across the range from 28.0 to 28.8 MHz. The quad's F/R remains above about 18.5 dB from 28.0 to 28.8 MHz. Meanwhile, the Yagi maintains an F/R of greater than 22 dB over the same range, but has almost 0.8 dB less gain compared to the quad at the low end of the band, eventually catching up at the high end of the band. The SWR for the quad is just over 2:1 at the bottom of the band, but remains less than 2:1 up to 28.8 MHz. The SWR on the Yagi remains less than 1.6:1 over the whole band.

Fig 4 shows the performance parameters for two 15-meter monoband designs: a five-element quad and a five-element Yagi, both on 26-foot booms. The quad is still the leader in gain, but has a less optimal rearward pattern and a somewhat less flat SWR curve than the Yagi. One thing should be noted in Figs 2 through 4. The F/R pattern on the Yagi is largely determined by the response at the 180° point, directly in back of the frontal lobe. This point is usually

### 10-M Optimized Monoband Quad vs Yagi 5-Ele. Quad/5-Ele. Yagi -- 26' Booms

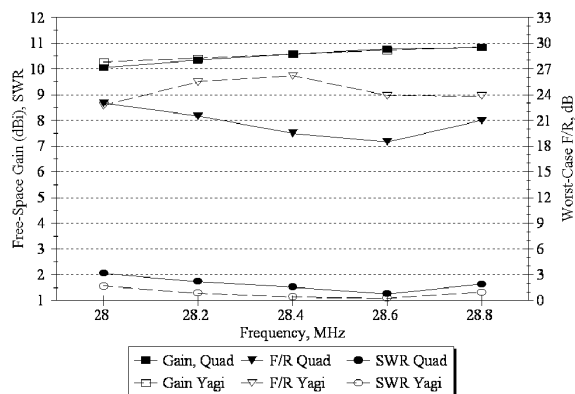


Fig 3—Comparison of gain, F/R and SWR over the 28.0 to 28.8-MHz range for an optimized five-element quad and an optimized five-element Yagi, both on 26-foot booms. The gain advantage of the quad is about 0.25 dB at the low end of the band. The F/R is more peaked in frequency for the quad, however, than the Yagi.

### 15-M Optimized Monoband Quad vs Yagi 5-Ele. Quad/5-Ele. Yagi, 26' Booms

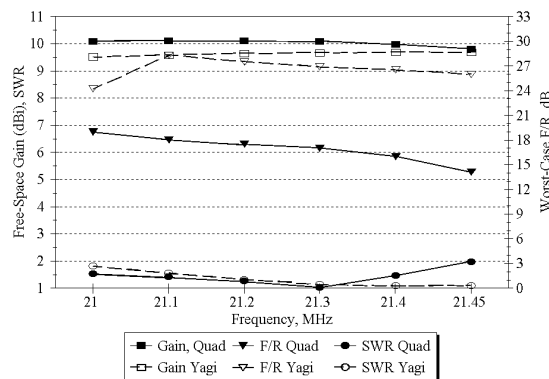


Fig 4—Comparison of gain, F/R and SWR over the 21.0 to 21.45-MHz range for an optimized 5-element quad and optimized 5-element Yagi, both on 26-foot booms. The quad enjoys a gain advantage of about 0.5 dB over most of the band. Its rearward pattern is not as good as the Yagi, which remains higher than 24 dB across the whole range, compared to the quad, which remains in the 16-dB average range.

referred to when discussing the “front-to-back ratio.”

The quad on the other hand has what a sailor might term “quartering lobes” (referring to the direction back towards the “quarterdeck” at the stern of a sailing vessel) in the rearward pattern. These quartering lobes are often worse than the response at 180°, directly in back of the main beam. Fig 5 overlays the free-space E-Field responses of the

15-meter quad and Yagi together. At 21.2 MHz, the quad actually has a front-to-back ratio (F/B) of about 24 dB, excellent in anyone's book. The Yagi at 180° has a F/B of about 25 dB, again excellent.

However, at an azimuth angle of about 125° (and at 235° azimuth on the other side of the main lobe) the quad's "quartering lobe" is down only some 17 dB, setting the worst-case F/R at 17 dB also. As explained in Chapter 11, the reason F/R is more important than just the F/B is that on receive signals can come from any direction, not just from directly behind the main beam.

Table 1 lists the dimensions for the three computer-optimized monoband quads shown in Figs 2, 3 and 4.

**15-Meter 5-Ele. Quad and 5-Ele. Yagi**  
21.2 MHz, 26-Foot Booms, Free Space

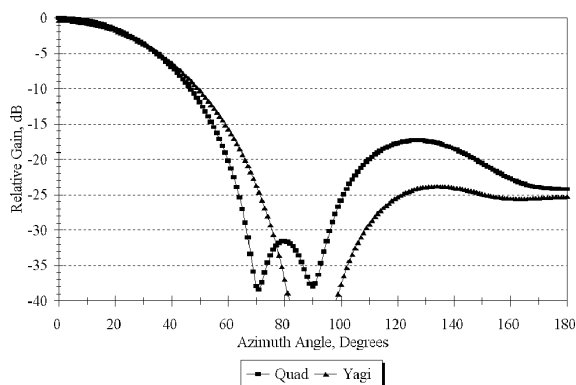


Fig 5—Comparing the pattern of the 15-meter quad and Yagi shown in Fig 4. The quad has a slightly narrower frontal beamwidth (it has 0.5 dB more gain than the Yagi), but has higher “rear quartering” sidelobes at about 125° (with a twin sidelobe, not shown, at 235°). These sidelobes limit the worst-case front-to-rear (F/R) to about 17 dB, while the F/B (at 180°, directly at the back of the quad) is more than 24 dB for each antenna.

**Table 1**  
**Dimensions for Optimized Monoband Quads in Figs 2, 3 and 4, on 26-Foot Booms**

	14.2 MHz	21.2 MHz	28.4 MHz
Reflector	73' 9"	49' 6"	37' 3"
R-DE Spacing	17' 8"	7'	6' 4"
Driven Element	71' 8"	47' 6"	35' 9"
DE-D1 Spacing	8' 3"	5'	5' 6"
Director 1	68' 7"	46' 8"	34' 8"
D1-D2 Spacing	—	6' 8"	6' 9"
Director 2	—	46' 10"	35' 2"
D2-D3 Spacing	—	7' 4"	7' 5"
Director 3	—	45' 8"	34' 2"
Feed method	Direct 50 Ω	Direct 50 Ω	Direct 50 Ω

## Is a Quad Better at Low Heights than a Yagi?

Another belief held by some quads enthusiasts is that they need not be mounted very high off the ground to give excellent DX performance. Quads are somehow supposed to be greatly superior to a Yagi at the same height above ground. Unfortunately, this is mainly wishful thinking.

Fig 6 compares the same two 10-meter antennas as in Fig 3, but this time with each one mounted on a 50-foot tower over flat ground, rather than in theoretical free space. The quad does indeed have slightly more gain than a Yagi with the same boom length, as it has in free space. This is evidenced by the very slight compression of the quad's main lobe, but is more obvious when you look at the third lobe, which peaks at about 53° elevation. In effect, the quad squeezes some energy out of its second and third lobes and adds that to the first lobe. However, the difference in gain compared to the Yagi is only 0.8 dB for this particular quad design at a 9° elevation angle. And while it's true that every dB counts, you can also be certain that on the air you wouldn't be able to tell the difference between the two antennas. After all, a 10- to 20-dB variation in the level signals is pretty common because of fading at HF.

## Multiband Quads

On the other hand, one of the valid reasons quads have remained popular over the years is that antenna homebrewers can build multiband quads far more easily they can construct

**10-Meter Optimized Quad and Yagi**  
28.4 MHz Gain, 50' Height

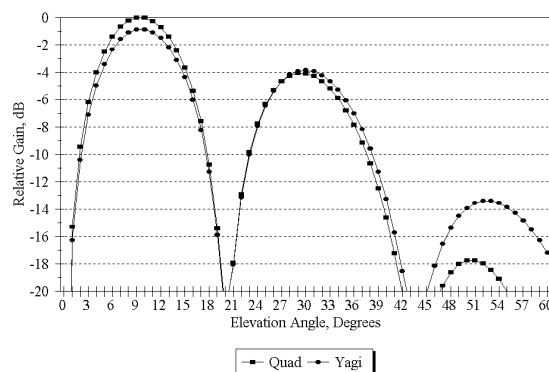


Fig 6—A comparison on 10 meters between an optimized five-element quad and an optimized five-element Yagi, both mounted 50 feet high over flat ground and both employing 26-foot booms. There is no appreciable difference in the peak elevation angle for either antenna. In other words, a quad does not have an appreciable elevation-angle advantage over a Yagi mounted at the same boom height. Note that the quad achieves its slightly higher gain by taking energy from higher-angle lobes and concentrating that energy in the main elevation lobe. This is a process that is similar to what happens with stacked Yagis.

multiband Yagis. In effect, all you have to do with a quad is add more wire to the existing support arms. It's not quite as simple as that, of course, but the idea of ready expandability for other bands is very appealing to experimenters.

Like the Yagi, the quad does suffer from interactions between wires of different frequencies, but the degree of interaction between bands is usually less for a quad. The higher-frequency bands are the ones that often suffer most from any interaction, for both Yagis and quads. For example, the 10- and 15-meter bands are usually the ones affected most by nearby 20-meter wires in a triband quad, while the 20-meter elements are not affected by the 10- or 15-meter elements.

Modern computer modeling software can help you counteract at least some of the interaction by allowing you to do virtual "retuning" of the quad on the computer screen — rather than clinging precariously to your tower fiddling with wires. However, the programs (such as *NEC-2* or *EZNEC*) that can model three-dimensional wire antennas such as quads typically run far more slowly than those designed for monoband Yagis (such as *YW* included with this book). This makes optimizing rather tedious, but you use the same considerations for tradeoffs between gain, pattern (F/R) and SWR over the operating bandwidth as you do with monoband Yagis.

### CONSTRUCTING A QUAD

The parasitic element shown in [Fig 1](#) is tuned in much the same way as the parasitic element in a Yagi antenna. That is, the parasitic loop is tuned to a lower frequency than the driven element when the parasitic is to act as a reflector, and to a higher frequency when it is to act as a director. [Fig 1](#) shows the parasitic element with an adjustable tuning stub, a convenient method of tuning since the resonant frequency can be changed simply by changing the position of the shorting bar on the stub. In practice, it has been found that the length around the loop should be approximately 3.5% greater than the self-resonant length if the element is a reflector, and about 3.0% shorter than the self-resonant length if the parasitic element is a director. Approximate formulas for the loop lengths in feet are:

$$\text{Driven Element} = \frac{1008}{f_{\text{MHz}}}$$

$$\text{Reflector} = \frac{1045}{f_{\text{MHz}}}$$

$$\text{Director} = \frac{977}{f_{\text{MHz}}}$$

These are valid for quad antennas intended for operation below 30 MHz and using uninsulated #14 stranded copper wire. At VHF, where the ratio of loop circumference to conductor diameter is usually relatively small, the circumference must be increased in comparison to the wavelength. For example, a one-wavelength loop constructed of 1/4-inch tubing for 144 MHz should have a circumference

about 2% greater than in the above equation for the driven element.

Element spacings on the order of 0.14 to 0.2 free-space wavelengths are generally used. You would employ the smaller spacings for antennas with more than two elements, where the structural support for elements with larger spacings tends to become challenging. The feed-point impedances of antennas having element spacings on this order have been found to be in the 40- to 60-Ω range, so the driven element can be fed directly with coaxial cable with only a small mismatch.

For spacings on the order of 0.25 wavelength (physically feasible for two elements, or for several elements at 28 MHz) the impedance more closely approximates the impedance of a driven loop alone—that is, 80 to 100 Ω. The feed methods described in [Chapter 26](#) can be used, just as in the case of the Yagi.

### Making It Sturdy

The physical sturdiness of a quad is directly proportional to the quality of the material used and the care with which it is constructed. The size and type of wire selected for use with a quad antenna is important because it will determine the capability of the spreaders to withstand high winds and ice. One of the more common problems confronting the quad owner is that of broken wires. A solid conductor is more apt to break than stranded wire under constant flexing conditions. For this reason, stranded copper wire is recommended. For 14-, 21- or 28-MHz operation, #14 or #12 stranded wire is a good choice. Soldering of the stranded wire at points where flexing is likely to occur should be avoided.

You may connect the wires to the spreader arms in many ways. The simplest method is to drill holes through the fiberglass at the appropriate points on the arms and route the wires through the holes. Soldering a wire loop across the spreader, as shown later, is recommended. However, you should take care to prevent solder from flowing to the corner point where flexing could break it.

While a boom diameter of 2 inches is sufficient for smaller quads using two or even three elements for 14, 21 and 28 MHz, when the boom length reaches 20 feet or longer a 3-inch diameter boom is highly recommended. Wind creates two forces on the boom, vertical and horizontal. The vertical load on the boom can be reduced with a guy-wire truss cable. The horizontal forces on the boom are more difficult to relieve, so 3-inch diameter tubing is desirable.

Generally speaking, three grades of material can be used for quad spreaders. The least expensive material is bamboo. Bamboo, however, is also the weakest material normally used for quad construction. It has a short life, typically only three or four years, and will not withstand a harsh climate very well. Also, bamboo is heavy in contrast to fiberglass, which weighs only about a pound per 13-foot length. Fiberglass is the most popular type of spreader material, and will withstand normal winter climates. One step beyond the conventional fiberglass arm is the pole-

vaulting arm. For quads designed to be used on 7 MHz, surplus “rejected” pole-vaulting poles are highly recommended. Their ability to withstand large amounts of bending is very desirable. The cost of these poles is high, and they are difficult to obtain. See [Chapter 21](#) for dealers and manufacturers of spreaders.

### Diamond or Square?

The question of how to orient the spreader arms has been raised many times over the years. Should you mount the loops in a diamond or a square configuration? Should one set of spreaders be horizontal to the earth as shown in [Fig 1](#) (right), or should the wire itself be horizontal to the ground (spreaders mounted in the fashion of an X) as shown in [Fig 1](#) (left)? From the electrical point of view, there is not enough difference in performance to worry about.

From the mechanical point of view there is no question which version is better. The diamond quad, with the associated horizontal and vertical spreader arms, is capable of holding an ice load much better than a system where no

vertical support exists to hold the wire loops upright. Put another way, the vertical poles of a diamond array, if sufficiently strong, will hold the rest of the system erect. When water droplets are accumulating and forming into ice, it is very reassuring to see water running down the wires to a corner and dripping off, rather than just sitting there on the wires and freezing. The wires of a loop (or several loops, in the case of a multiband antenna) help support the horizontal spreaders under a load of ice. A square quad will droop severely under heavy ice conditions because there is nothing to hold it up straight.

Of course, in climates where icing is not a problem, many amateurs point out that they like the aesthetics of the square configuration. There are thousands of square-configuration quads in temperate areas around the world.

Another consideration will enter into your choice of orientation for a quad. You must mount a diamond quad somewhat higher on the mast or tower than for an equivalent square array, just to keep the bottom spreader away from the tower guys when you rotate the antenna.

## Two Multiband Quads

This section describes two multiband quad designs. The first is a large triband 20/15/10-meter quad built on a 26-foot boom made of 3-inch irrigation tubing. This antenna has three elements on 20 meters, four elements on 15 meters, and five elements on 10 meters. [Fig 7](#) shows a photograph of the five-element triband quad.

The second project is a compact two-element triband quad on an 8-foot boom that covers 20, 17, 15, 12 and 10 meters. We call this a “pentaband” quad since it covers five bands. This antenna uses five concentric wire loops mounted on the each of the two sets of spreaders. Either antenna may be constructed in a diamond or square configuration.

While the same basic construction techniques are employed for both multiband quads, the scale of the larger triband antenna makes it a far more ambitious undertaking! The large quad requires a strong tower and a rugged rotator. It also requires a fair amount of real estate in order to raise the quad to the top of the tower without entangling trees or other antennas.

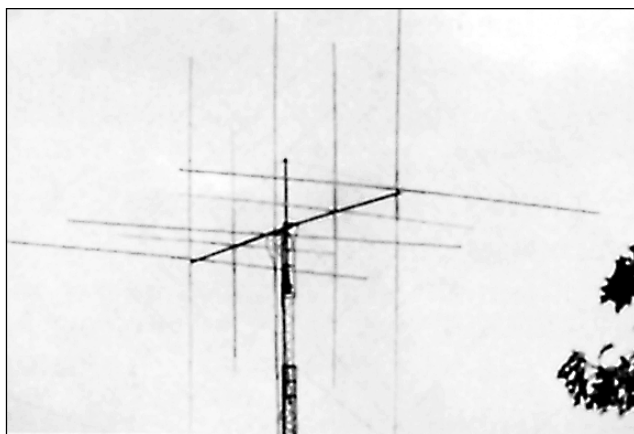
### A FIVE-ELEMENT, 26-FOOT BOOM TRIBAND QUAD

Five sets of element spreaders are used to support the three elements used on 14 MHz, four elements on 21 MHz and five elements on 28-MHz. We chose to use four elements on 15 meters in this design (rather than the five we could have been employed on this length of boom) because the difference in optimized performance wasn’t great enough to warrant the extra complexity of using five elements. The

dimensions are listed in [Table 2](#), and are designed for center frequencies of 14.175, 21.2 and 28.4 MHz.

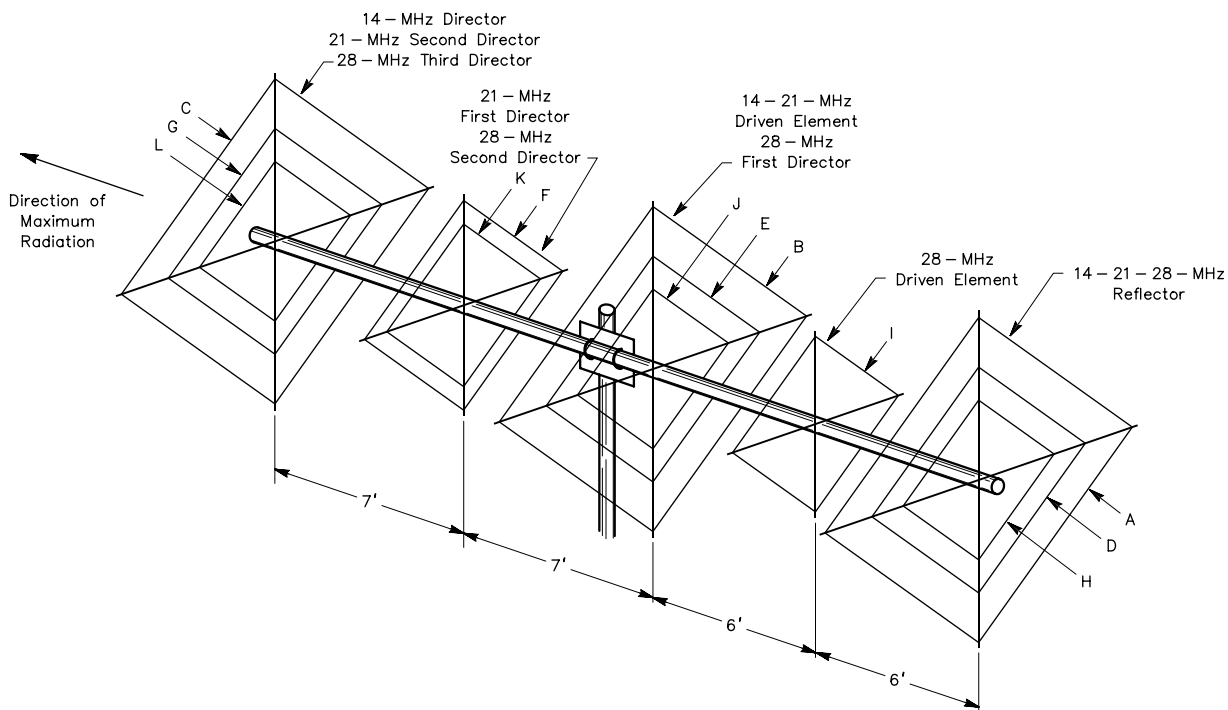
The spacing between elements has been chosen to provide good compromises in performance consistent with boom length and mechanical construction. You can see that the element spacings for 20 meters are quite different from those for the optimized monoband design. This is because the same set of spreaders is used for all three bands on three out of the five elements, and the higher-frequency bands dictate the spacing because they are more critical.

Each of the parasitic loops is closed (ends soldered together) and requires no tuning. [Fig 8](#) shows the physical



**Fig 7**—Photo of the three-band, five-element quad antenna.





**Fig 8—Layout for the three-band, five-element quad, not drawn to scale. See Table 2 for dimensions.**

layout of the triband quad. **Fig 9** plots the computed free-space gain, front-to-rear ratio and SWR response across the 20-meter band. With only a few degrees of freedom in tuning and spacing of the three elements, it is impossible to spread the response out to cover the entire 20-meter band. The compromise design results in a rearward pattern that varies from a worst-case of just under 10 dB at the high end of the band, to a peak F/R of just under 19 dB at 14.2 MHz, in the phone portion of the band. The F/R is about 11 dB at the low end of the band.

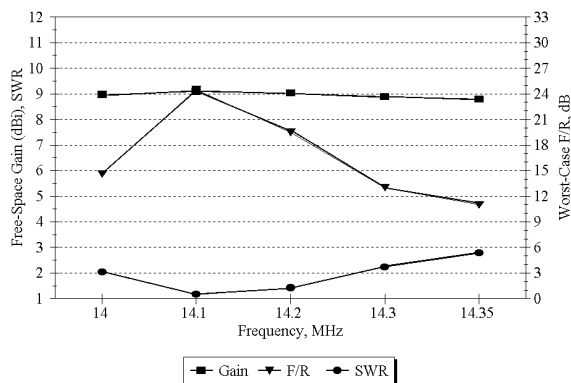
The SWR remains under 3:1 for the entire 20-meter band, rising to 2.8:1 at the high end. The feed system for this triband quad consists of three separate 50-Ω coax lines,

one per driven element, together with a relay switchbox mounted to the boom so that a single coax can be used back to the operating position. Each feed line uses a ferrite-bead balun to control common-mode currents and preserve the radiation pattern and each coax going to the switchbox is

**Table 2**  
**Three-Band Five-Element Quad on 26-Foot Boom**

	14.15 MHz	21.2 MHz	28.4 MHz
Reflector	72' 6"	49' 4"	36' 8"
R-DE Spacing	12'	12'	6'
Driven Element	71'	47' 6"	35' 4"
DE-D1 Spacing	14'	7'	6'
Director 1	68' 6"	46' 8"	34' 8"
D1-D2 Spacing	—	14'	7'
Director 2	—	46' 5"	34' 8"
D2-D3 Spacing	—	—	7'
Director 3	—	—	34'
Feed method	Direct 50 Ω	Direct 50 Ω	Direct 50 Ω

**20-Meter Optimized Triband Quad**  
3-Ele. Quad, 26' Boom



**Fig 9—Computed performance of the triband, five-element quad over the 20-meter band. The direct 50-Ω feed system holds the SWR below 2.8: 1 across the whole band. This could be improved with a gamma-match system tuned to 14.1 MHz if the builder really desires a low SWR. The F/R peaks at 14.1 MHz and remains above 10 dB across the whole band.**

cut to be an electrical three-quarter wavelength on 15 meters. This presents a short at the unused driven elements since modeling indicated that the 15-meter band is adversely affected by the presence of the 20-meter driven element if it is left open-circuited. If you use RG-213 coax, the  $3/4\lambda$  electrical length of each feed line is 23 feet long at 21.2 MHz. This is sufficient physical length to reach each driven element from the switchbox.

Fig 10 shows the free-space response for the 15-meter band. The rearward response is roughly 15 dB across the band. This is a result of the residual interaction between the 20-meter elements on 15 meters, and no further tuning could improve the F/R. Note how flat the SWR curve is. This SWR characteristic is what gives the quad the reputation of being “wideband.” A flat SWR curve, however, is not necessarily a good indicator of optimal performance for directional antennas like quads or Yagis, particularly multiband designs where compromises must be made by physical necessity.

Fig 11 shows the characteristics of the 10-meter portion of the two-element triband quad. The response favors the low-phone band, with the F/R falling to about 12 dB at the low end of the frequency range and rising to just about 23 dB at 28.4 MHz. The SWR curve is once again relatively flat across the major portion of the band up to 28.8 MHz.

### Construction

The most obvious problem related to quad antennas is the ability to build a structurally sound system. If high winds or heavy ice are a normal part of the environment, special precautions are necessary if the antenna is to survive a winter season. Another stumbling block for would-be quad builders is the installation of a three-dimensional system (assuming a Yagi has only two important dimensions) on top of a tower—especially if the tower needs guy wires for support. With proper planning, however, many of these obstacles can

be overcome. For example, a tram system may be used.

Both multiband quad arrays use fiberglass spreaders (see Chapter 21 for suppliers). Bamboo is a suitable substitute (if economy is of great importance). However, the additional weight of the bamboo spreaders over fiberglass is an important consideration. A typical 12-foot bamboo pole weighs about 2 pounds; the fiberglass type weighs less than a pound. By multiplying the difference times 8 for a two-element array, times 12 for a three-element antenna, and so on, it quickly becomes apparent that fiberglass is worth the investment if weight is an important factor. Properly treated, bamboo has a useful life of three or four years, while fiberglass life is probably 10 times longer.

Spreader supports (sometimes called *spiders*) are available from many different manufacturers. If the builder is keeping the cost at a minimum, he should consider building his own. The expense is about half that of a commercially manufactured equivalent and, according to some authorities, the homemade arm supports described below are less likely to rotate on the boom as a result of wind pressure.

A 3-foot length of steel angle stock, 1 inch per side, is used to interconnect the pairs of spreader arms. The steel is drilled at the center to accept a muffler clamp of sufficient size to clamp the assembly to the boom. The fiberglass is clamped to the steel angle stock with automotive hose clamps, two per pole. Each quad-loop spreader frame consists of two assemblies of the type shown in Fig 12.

Connecting the wires to the fiberglass can be done in a number of different ways. Holes can be drilled at the proper places on the spreader arms and the wires run through them. A separate wrap wire should be included at the entry/exit point to prevent the loop from slipping. Details are presented in Fig 13. Some amateurs have experienced cracking of the fiberglass, which might be a result of drilling holes through the material. However, this seems to be the exception rather

**15-Meter Optimized Triband Quad**  
4-Ele. Quad, 26' Boom

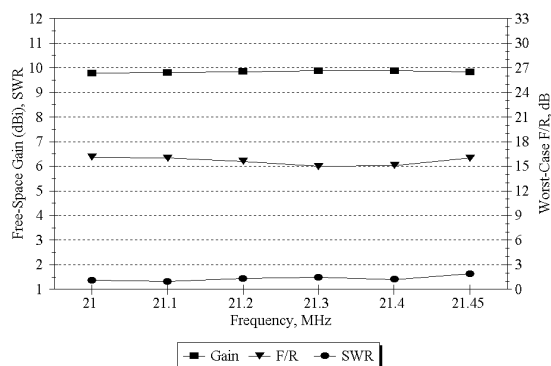


Fig 10—Computed performance of the triband, five-element quad over the 15-meter band. There is some degree of interaction with the 20-meter elements, limiting the worst-case F/R to about 15 dB. The gain and SWR curves are relatively flat across the band.

**10-Meter Optimized Triband Quad**  
5-Ele. Quad, 26' Boom

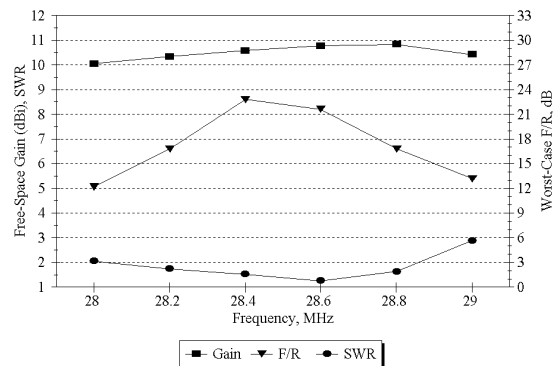
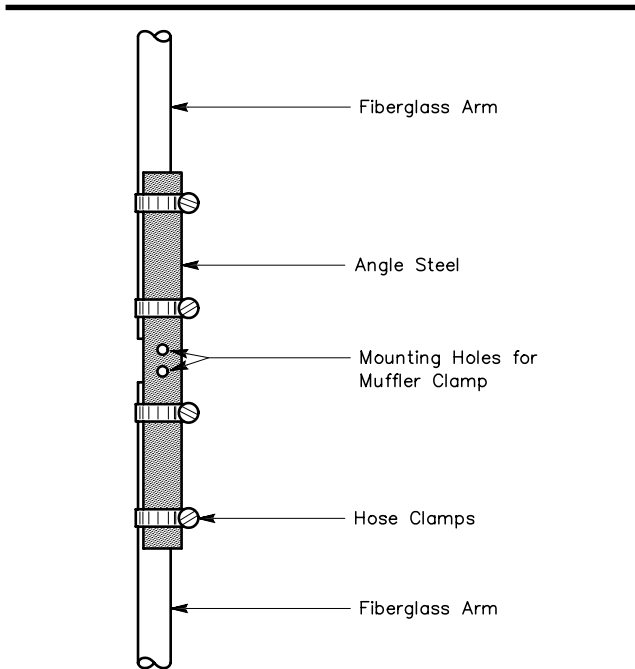


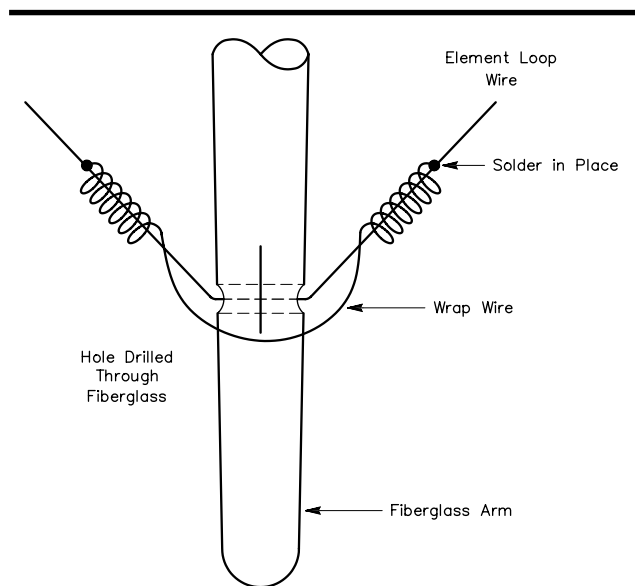
Fig 11—Computed performance of the triband, five-element quad over the 10-meter band. The F/R is higher than 12 dB across the band from 28.0 to 29.0 MHz, but the SWR rises at the top end of the band beyond 2:1. The free-space gain is higher than 10 dBi across the band.

than the rule. The model described here has no holes in the spreader arms; the wires are attached to each arm with a few layers of plastic electrical tape and then wrapped approximately 20 times in a crisscross fashion with 1/8-inch diameter nylon string, followed by more electrical tape for UV protection, as shown in Fig 14.

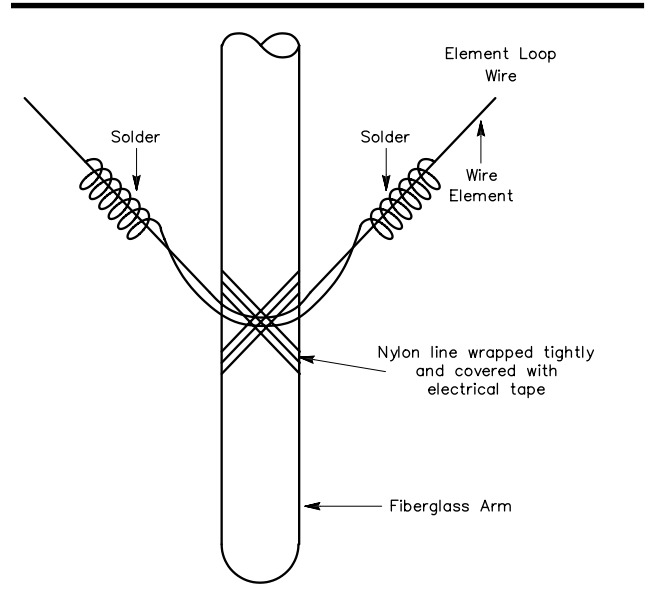
The wire loops are left open at the bottom of each driven



**Fig 12—Details of one of two assemblies for a spreader frame. The two assemblies are joined back-to-back to form an X with a muffer clamp mounted at the position shown.**



**Fig 13—A method of assembling a corner of the wire loop of a quad element to the spreader arm.**



**Fig 14—An alternative method of assembling the wire of a quad loop to the spreader arm.**

element where the feed-line coaxes are attached. All of the parasitic elements are continuous loops of wire; the solder joint is at the base of the diamond.

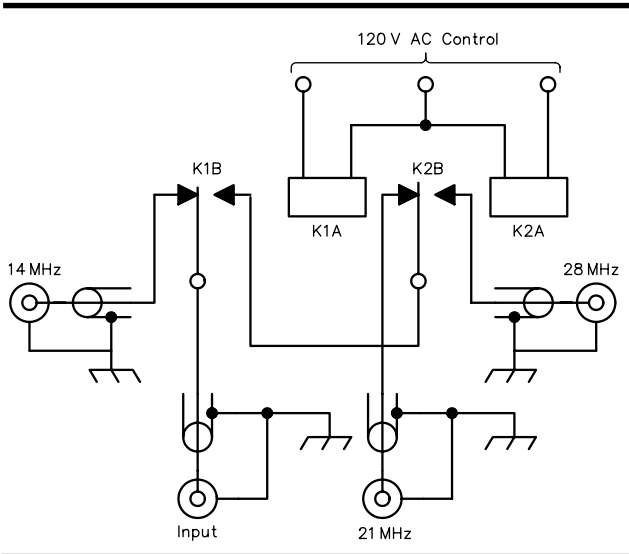
Although you could run three separate coax cables down to the shack, we suggest that you install a relay box at the center of the boom. A three-wire control system may be used to apply power to the proper relay for changing bands. The circuit diagram of a typical configuration is presented in Fig 15 and its installation is shown in Fig 16.

Every effort must be placed upon proper construction if you want to have freedom from mechanical problems. Hardware must be secure or vibration created by the wind may cause separation of assemblies. Solder joints should be clamped in place to keep them from flexing, which might fracture a connection point.

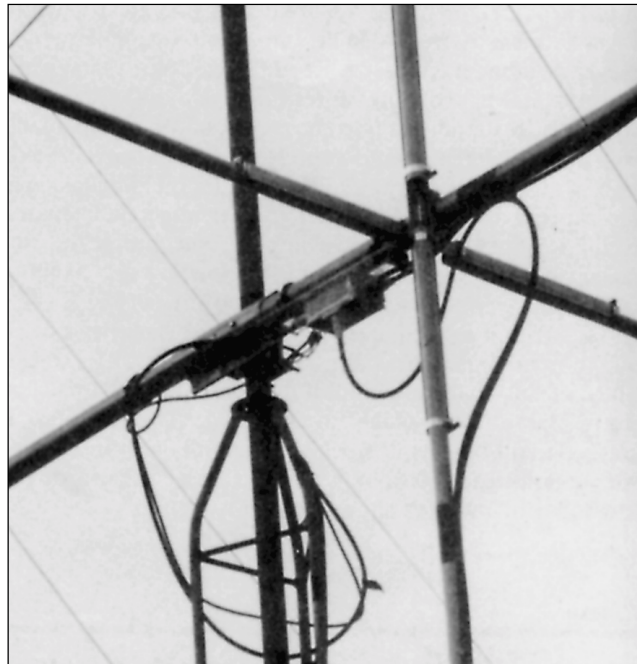
### A TWO-ELEMENT, 8-FOOT BOOM PENTABAND QUAD

This two-element pentaband (20/17/15/12/10-meter) quad uses the same construction techniques as its big brother above. Since only two elements are used, the boom can be less robust for this antenna, at 2 inches diameter rather than 3 inches. Those who like really rugged antennas can still use the 3-inch diameter boom, of course.

Table 3 lists the element dimensions for the pentaband quad. The following plots show the performance for each of the five bands covered. The feed system for the pentaband quad uses five, direct 50-Ω coaxes, one to each driven element. These five coaxes are cut to be  $3/4-\lambda$  electrically on 10 meters (17 feet, 2 inches for RG-213 at 28.4 MHz). In this design the 10-meter band is the one most affected by the presence of the other driven elements if they are left unshorted. The  $3/4-\lambda$  lines open-circuited at the switchbox are long enough physically to reach all elements from a



**Fig 15—Suitable circuit for relay switching of bands for the three-band quad. A three-wire control cable is required. K1, K2—any type of relay suitable for RF switching, coaxial type not required (Potter and Brumfeld MR11A acceptable; although this type has double-pole contacts, mechanical arrangements of most single-pole relays make them unacceptable for switching of RF).**



**Fig 16—The relay box is mounted on the boom near the center. Each of the spreader-arm fiberglass poles is attached to steel angle stock with hose clamps.**

centrally mounted switchbox. This length assumes that the switchbox open-circuits the unused coaxes. If the switchbox short-circuits unused coaxes (as several commercial switchboxes do), then use  $\frac{3}{4}\lambda$  long lines to feed all five driven elements (11 feet, 5 inches for RG-213 at 28.4 MHz).

The SWR curves do not necessarily go down to 1:1 because of this simple, direct feed system. If anyone is bothered by this, of course they can always implement individual matching systems, such as gamma matches. Most amateurs would agree that such a degree of complexity is not warranted. The worst-case SWR is less than 2.3:1 on each band, even with direct feed on 20 meters. With typical lengths of coaxial feed line from the shack to the switchbox at the antenna, say 100 feet of RG-213, the SWR at the transmitter would be less than 2.0:1 on all bands due to losses in the feed line.

**Fig 17** shows the computed responses for the pentaband quad over the 20-meter band. With only two degrees of freedom (spacing and element tuning) there is not much that

can be done to spread the response out over the entire 20-meter band. Nonetheless, the performance over the band is still pretty reasonable for an antenna this small. The F/R pattern peaks at 19 dB at 14.1 MHz and falls to about 10 dB at either end of the band. The free-space gain varies from about 7.5 dBi to just above 6 dBi, comparable to a short-boom three-element Yagi. The SWR curve remains below 2.3:1 across the band. If you were to employ a gamma match tuned at 14.1 MHz, you could limit the peak SWR to less than 2.0:1, and this would still occur at 14.0 MHz.

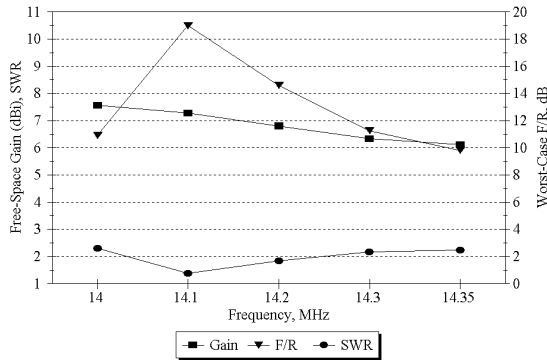
On 17 meters, **Fig 18** shows that the other elements are affecting 18 MHz, even with element-length optimization. Careful examination of the current induced on the other elements shows that the 20-meter driven element is interacting on 18 MHz, deteriorating the pattern and gain slightly. Even still, the performance on 17 meters is reasonable, especially for a five-band quad on an 8-foot boom.

On 15 meters, the interactions seems to have been contained, as **Fig 19** demonstrates. The F/R peaks at

**Table 3  
Five-Band Two-Element Quad on 8-Foot Boom**

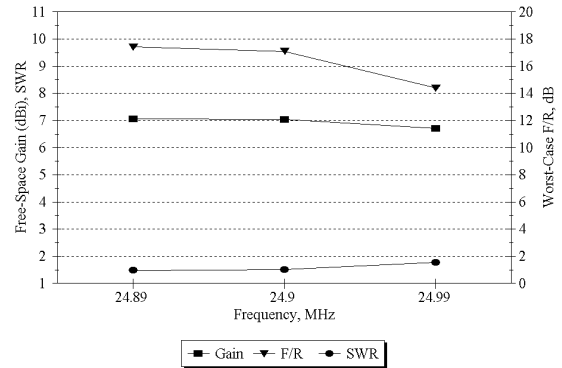
	14.2 MHz	18.1 MHz	21 MHz	24.9 MHz	28.4 MHz
Reflector	72' 4"	56' 4"	48' 6"	40' 11 $\frac{1}{4}$ "	37' 5 $\frac{1}{2}$ "
R-DE Spacing	8'	8'	8'	8'	8'
Driven Element	69' 10 $\frac{1}{2}$ "	54' 10 $\frac{1}{2}$ "	46' 7"	39' 10 $\frac{1}{2}$ "	34' 6"

**20-Meters, Optimized Pentaband Quad**  
2-Ele. Quad, 8' Boom



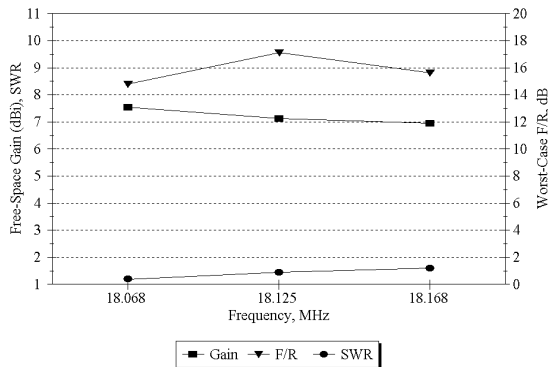
**Fig 17**—Computed performance of the pentaband two-element quad on 20 meters. With the simple direct-feed system, the SWR rises to about 2.3:1 at the low end of the band. A gamma match can bring the SWR down to 1:1 at 14.1 MHz, if desired.

**12 Meters, Optimized Pentaband Quad**  
2-Ele. Quad, 8' Boom



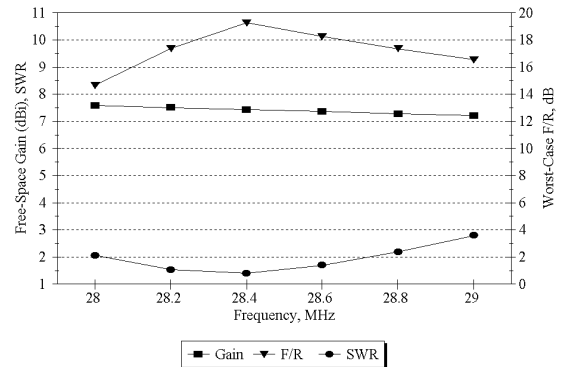
**Fig 20**—Computed performance of the pentaband two-element quad on 12 meters.

**17 Meters, Optimized Pentaband Quad**  
2-Ele. Quad, 8' Boom



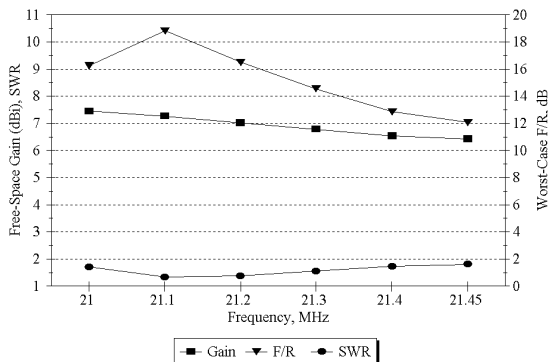
**Fig 18**—Computed performance of the pentaband two-element quad on 17 meters. There is some interaction with the other elements, but overall the performance is satisfactory on this band.

**10 Meters, Optimized Pentaband Quad**  
2-Ele. Quad, 8' Boom



**Fig 21**—Computed performance of the pentaband two-element quad on 10 meters. The SWR curve is slightly above the target 2:1 at the low end of the band and rises to about 2.2:1 at 28.8 MHz. This unlikely to be a problem, even with rigs with automatic power-reduction due to SWR, since the SWR at the input of a typical coax feed line will be lower than that at the antenna due to losses in the line.

**15 Meters, Optimized Pentaband Quad**  
2-Ele. Quad, 8' Boom



**Fig 19**—Computed performance of the pentaband two-element quad on 15 meters. The performance is acceptable across the whole band.

21.1 MHz, at 19 dB and remains better than 12 dB past the top of the band. The SWR curve is low across the whole band.

On 12 meters, the interaction between bands is minor, leading to the good results shown in Fig 20. The SWR change across this band is quite flat, which isn't surprising given the narrow bandwidth of the 12-meter band.

On 10 meters, the interaction seems to have been tamed well by computer-tuning of the elements. The F/R remains higher than about 14 dB from 28 to 29 MHz. The SWR remains below 2.2:1 up to about 28.8 MHz, while the gain is relatively flat across the band at more than 7.2 dBi in free space. See Fig 21.

Overall, this pentaband quad is physically compact and yet it provides good performance across all five bands. It is competitive with commercial Log Periodic Dipole Array (LPDA) designs and triband Yagi designs that employ longer booms.

### BIBLIOGRAPHY

Source material and more extended discussions of

the topics covered in this chapter can be found in the references given below and in the textbooks listed at the end of Chapter 2.

- P. S. Carter, C. W. Hansell and N. E. Lindenblad, "Development of Directive Transmitting Antennas by R.C.A. Communications," *Proc. IRE*, Oct 1931.
- C. Cleveland, "More'n One Way to Switch an Antenna," *Technical Correspondence, QST*, Nov 1986.
- D. Cutter, "Simple Switcher," 73, May 1980.
- D. DeMaw, "A Remote Antenna Switcher for HF," *QST*, Jun 1986.
- M. G. Knitter, Ed., *Loop Antennas—Design and Theory* (Cambridge, WI: National Radio Club, 1983).
- H. Landskov, W7KAR, "Evolution of a Quad Array," *QST*, Mar 1977.
- J. Lindsay, "Quads and Yagis," *QST*, May 1968.
- F. E. Terman, *Radio Engineering*, 3rd ed. (New York: McGraw-Hill Book Co, 1947).
- E. M. Williams, "Radiating Characteristics of Short-Wave Loop Aerials," *Proc. IRE*, Oct 1940.

# Long-Wire and Traveling-Wave Antennas

The power gain and directive characteristics of electrically long wires (that is, wires that are long in terms of wavelength), as described in [Chapter 2](#), make them useful for long-distance transmission and reception on the higher frequencies. Long wires can be combined to form antennas of various shapes that increase the gain and directivity over a single wire. The term *long wire*, as used in this chapter, means any such configuration, not just a straight-wire antenna.

## LONG WIRES VERSUS MULTIELEMENT ARRAYS

In general, the gain obtained with long-wire antennas is not as great, when the space available for the antenna is limited, as you can obtain from the multielement phased arrays in [Chapter 8](#) or from a parasitic array such as a Yagi or quad ([Chapters 11](#) or [12](#)). However, the long-wire antenna has advantages of its own that tend to compensate for this deficiency. The construction of long-wire antennas is simple both electrically and mechanically, and there are no especially critical dimensions or adjustments. The long-wire antenna will work well and give satisfactory gain and directivity over a 2-to-1 frequency range. In addition, it will accept power and radiate well on any frequency for which its overall length is not less than about a half wavelength. Since a wire is not electrically long, even at 28 MHz, unless its physical length is equal to at least a half wavelength on 3.5 MHz, any long-wire can be used on all amateur bands that are useful for long-distance communication.

Between two directive antennas having the same theoretical gain, one a multielement array and the other a long-wire antenna, many amateurs have found that the long-wire antenna seems more effective in reception. One possible explanation is that there is a *diversity effect* with a long-wire antenna because it is spread out over a large distance, rather than being concentrated in a small space, as would be the case with a Yagi, for example. This may raise the average level of received energy for ionospheric-propagated signals. Another factor is that long-wire antennas have directive patterns that can be extremely sharp in the horizontal (azimuthal) plane. This is an advantage that other types of multielement arrays do not have, but it can be a double-

edged sword too. We'll discuss this aspect in some detail in this chapter.

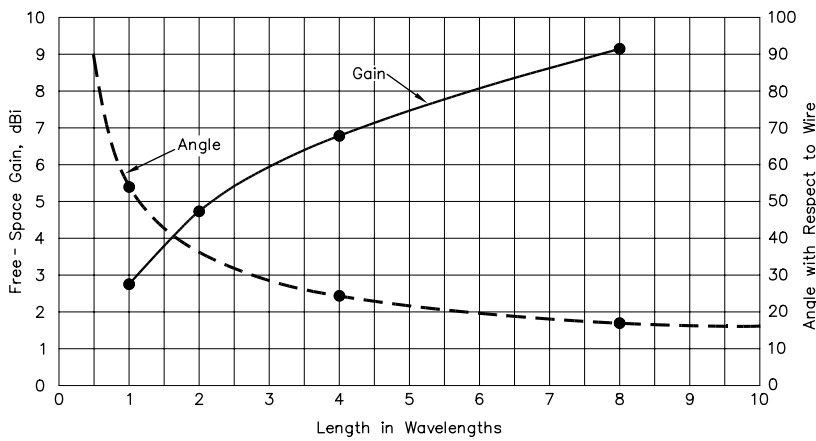
## GENERAL CHARACTERISTICS OF LONG-WIRE ANTENNAS

Whether the long-wire antenna is a single wire running in one direction or is formed into a V-beam, rhombic, or some other configuration, there are certain general principles that apply and some performance features that are common to all types. The first of these is that the power gain of a long-wire antenna as compared with a half-wave dipole is not considerable until the antenna is really long (its length measured in wavelengths rather than in a specific number of feet). The reason for this is that the fields radiated by elementary lengths of wire along the antenna do not combine, at a distance, in as simple a fashion as the fields from half-wave dipoles used in other types of directive arrays.

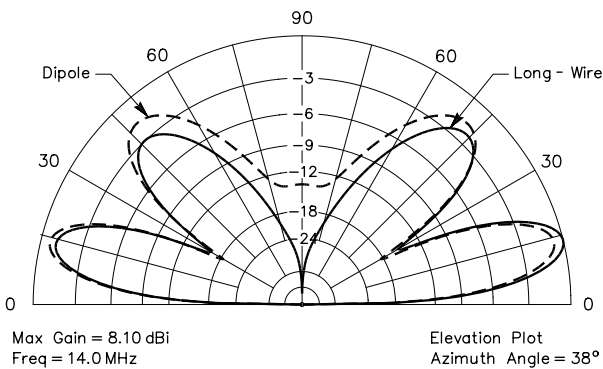
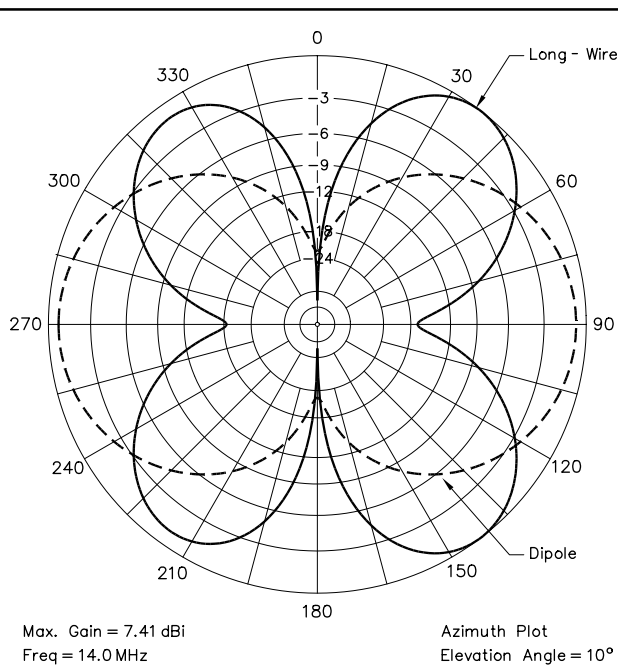
There is no point in space, for example, where the distant fields from all points along the wire are exactly in phase (as they are, in the optimum direction, in the case of two or more collinear or broadside dipoles when fed with in-phase currents). Consequently, the field strength at a distance is always less than would be obtained if the same length of wire were cut up into properly phased and separately driven dipoles. As the wire is made longer, the fields combine to form increasingly intense main lobes, but these lobes do not develop appreciably until the wire is several wavelengths long. See [Fig 1](#).

The longer the antenna, the sharper the lobes become, and since it is really a hollow cone of radiation about the wire in free space, it becomes sharper in both planes. Also, the greater the length, the smaller the angle with the wire at which the maximum radiation lobes occur. There are four main lobes to the directive patterns of long-wire antennas; each makes the same angle with respect to the wire.

[Fig 2A](#) shows the azimuthal radiation pattern of a  $1\text{-}\lambda$  long-wire antenna, compared with a  $\frac{1}{2}\text{-}\lambda$  dipole. Both antennas are mounted at the same height of  $1\lambda$  above flat ground (70 feet high at 14 MHz, with a wire length of 70 feet) and both patterns are for an elevation angle of  $10^\circ$ , an angle suitable for long-distance communication on 20 meters. The long-wire in [Fig 2A](#) is oriented in the  $270^\circ$  to



**Fig 1—Theoretical gain of a long-wire antenna, in dBi, as a function of wire length. The angle, with respect to the wire, at which the radiation intensity is maximum also is shown.**



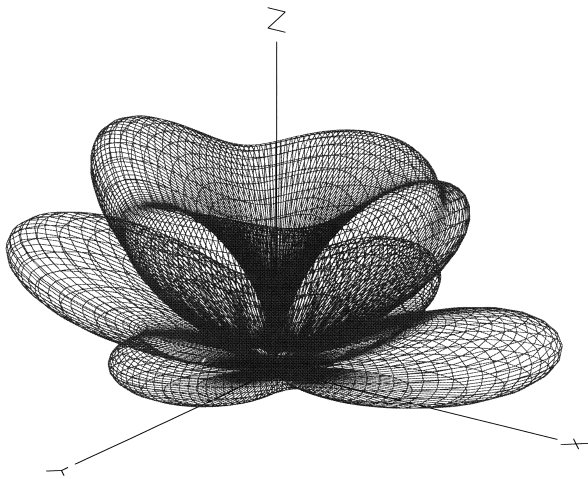
90° direction, while the dipole is aligned at right angles so that its characteristic figure-8 pattern goes left-to-right. The 1-λ long-wire has about 0.6 dB more gain than the dipole, with four main lobes as compared to the two lobes from the dipole.

You can see that the two lobes on the left side of Fig 2A are about 1 dB down compared to the two lobes on the right side. This is because the long-wire here is fed at the left-hand end in the computer model. Energy is radiated as a wave travels down the wire and some energy is also lost to ohmic resistance in the wire and the ground. The forward-going wave then reflects from the open-circuit at the right-hand end of the wire and reverses direction, traveling toward the left end, still radiating as it travels. An antenna operating in this way has much the same characteristics as a transmission line that is terminated in an open circuit—that is, it has standing waves on it. Underterminated long-wire antennas are often referred to as *standing wave antennas*. As the length of a long-wire antenna is increased, a moderate front-to-back ratio results, about 3 dB for very long antennas.

Fig 2B shows the elevation-plane pattern for the long-wire and for the dipole. In each case the elevation pattern is at the azimuth of maximum gain—at an angle of 38° with respect to the wire-axis for the long-wire and at 90° for the dipole. The peak elevation for the long-wire is very slightly lower than that for the dipole at the same height above ground, but not by much. In other words, the height above ground is the main determining factor for the shape of the main lobe of a long-wire's elevation pattern, as it is for most horizontally polarized antennas.

**Fig 2—At top, comparison of azimuthal patterns for a 1-λ long-wire antenna (solid line) and a 1/2-λ dipole (dashed line) at an elevation angle of 10°. Each antenna is located 1 λ (70 feet) over flat ground at 14 MHz. At bottom, the elevation-plane patterns at peak azimuth angles for each antenna. The long-wire has about 0.6 dB more gain than the dipole.**





**Fig 3—A 3-D representation of the radiation pattern for the 1-λ long-wire shown in Fig 2. The pattern is obviously rather complex. It gets even more complicated for wires longer than 1 λ.**

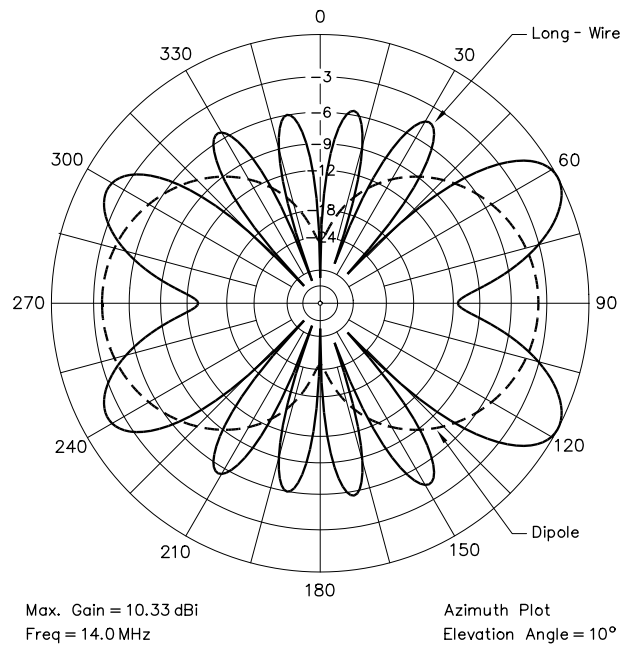
The shape of the azimuth and elevation patterns in Fig 2 might lead you to believe that the radiation pattern is simple. Fig 3 is a 3-D representation of the pattern from a 1-λ long-wire that is 1 λ high over flat ground. Besides the main low-angle lobes, there are strong lobes at higher angles. Things get even more complicated when the length of the long-wire increases.

### DIRECTIVITY

Because many points along a long wire are carrying currents in different phases (with different current amplitudes as well), the field pattern at a distance becomes more complex as the wire is made longer. This complexity is manifested in a series of minor lobes, the number of which increases with the wire length. The intensity of radiation from the minor lobes is frequently as great as, and sometimes greater than, the radiation from a half-wave dipole. The energy radiated in the minor lobes is not available to improve the gain in the major lobes, which is another reason why a long-wire antenna must be long to give appreciable gain in the desired directions.

Fig 4 shows an azimuthal-plane comparison between a 3-λ (209 feet long) long-wire and the comparison 1/2-λ dipole. The long-wire now has 8 minor lobes besides the four main lobes. Note that the angle the main lobes make with respect to the axis of the long-wire (also left-to-right in Fig 4) becomes smaller as the length of the long-wire increases. For the 3-λ long-wire, the main lobes occur 28° off the axis of the wire itself.

Other types of simple driven and parasitic arrays do not have minor lobes of any great consequence. For that reason they frequently seem to have much better directivity than long-wire antennas, because their responses in undesired directions are well down from their response in the desired

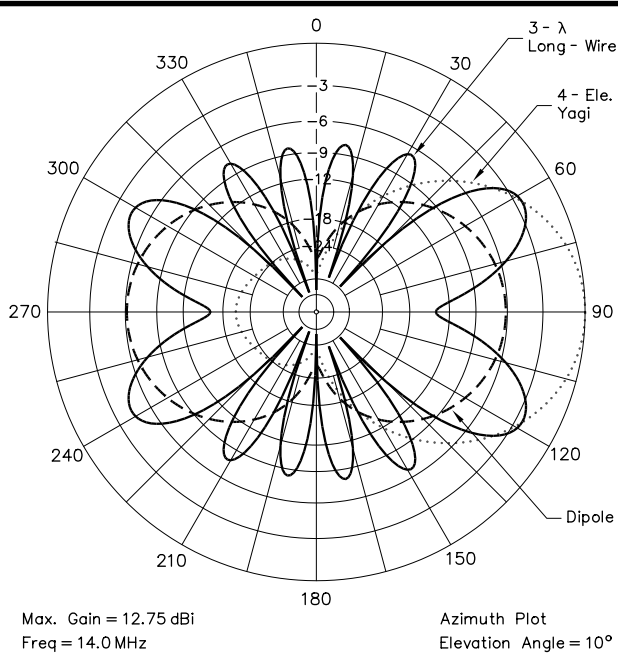


**Fig 4—An azimuthal-plane comparison between a 3-λ (209 feet long) long-wire (solid line) and the comparison 1/2-λ dipole (dashed line) at 70 feet high (1 λ) at 14 MHz.**

direction. This is the case even if a multielement array and a long-wire antenna have the same peak gain in the favored direction. Fig 5 compares the same 3-λ long-wire with a 4-element Yagi and a 1/2-λ dipole, again both at the same height as the long-wire. Note that the Yagi has only a single backlobe, down about 21 dB from its broad main lobe, which has a 3-dB beamwidth of 63°. The 3-dB beamwidth of the long-wire's main lobes (at a 28° angle from the wire axis) is far more narrow, at only 23°.

For amateur work, particularly with directive antennas that cannot be rotated, the minor lobes of a long-wire antenna have some advantages. Although the nulls in the computer model in Fig 5 are deeper than 30 dB, they are not so dramatic in actual practice. This is due to irregularities in the terrain that inevitably occur under the span of a long wire. In most directions the long-wire antenna will be as good as a half-wave dipole, and in addition will give high gain in the most favored directions, even though that is over narrow azimuths.

Fig 6A compares the azimuth responses for a 5-λ long-wire (350 feet long at 14 MHz) to the same 4-element Yagi and dipole. The long-wire now exhibits 16 minor lobes in addition to its four main lobes. The peaks of these sidelobes are down about 8 dB from the main lobes and they are stronger than the dipole, making this long-wire antenna effectively omnidirectional. Fig 6B shows the elevation pattern of the 5-λ long-wire at its most effective azimuth compared to a dipole. Again, the shape of the main lobe is



**Fig 5—A comparison between the 3-λ long-wire (solid line) in Fig 4, a 4-element 20-meter Yagi on a 26-foot boom (dotted line), and a 1/2-λ dipole (dashed line), again at a height of 70 feet. The main lobes of the long-wire are very narrow compared to the wide frontal lobe of the Yagi. The long-wire exhibits an azimuthal pattern that is more omnidirectional in nature than a Yagi, particularly when the narrow, deep nulls in the long-wire's pattern are filled-in due to irregularities in the terrain under its long span of wire.**

mainly determined by the long-wire's height above ground, since the peak angle is only just a bit lower than the peak angle for the dipole. The long-wire's elevation response breaks up into numerous lobes above the main lobes, just as it does in the azimuth plane.

For the really ambitious, Fig 7 compares the performance for an 8-λ (571 feet) long-wire antenna with a 4-element Yagi and the 1/2-λ dipole. Again, in actual practice, the nulls would tend to be filled in by terrain irregularities, so a very long antenna like this would be a pretty potent performer.

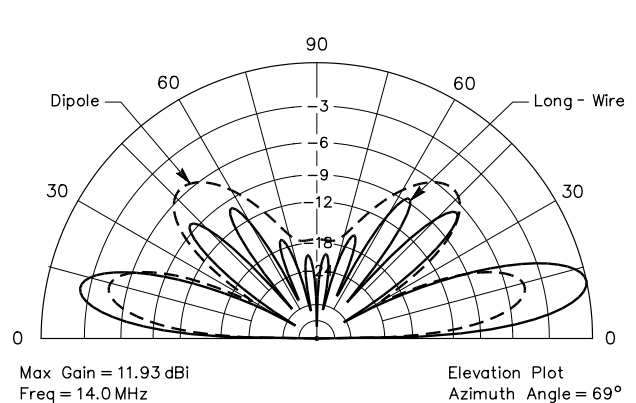
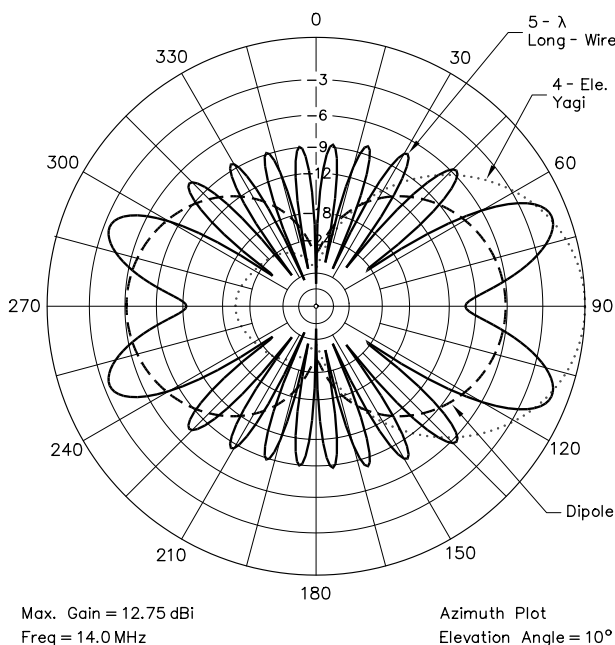
### CALCULATING LENGTH

In this chapter, lengths are discussed in terms of wavelengths. Throughout the preceding discussion the frequency in the models was held at 14 MHz. Remember that a long-wire that is 4 λ long at 14 MHz is 8 λ long at 28 MHz.

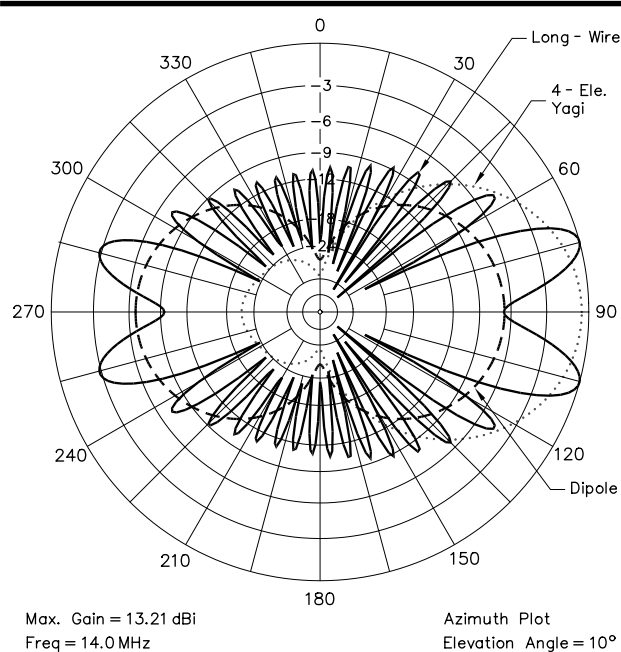
There is nothing very critical about wire lengths in an antenna system that will work over a frequency range including several amateur bands. The antenna characteristics change very slowly with length, except when the wires are short (around one wavelength, for instance). There is no need to try to establish exact resonance at a particular frequency for proper antenna operation.

The formula for determining the lengths for harmonic wires is:

$$\text{Length (feet)} = \frac{984 (N - 0.025)}{f \text{ (MHz)}} \quad (\text{Eq 1})$$



**Fig 6—At left, the azimuth responses for a 5-λ long-wire (350 feet long at 14 MHz—solid line) to the same 4-element Yagi (dotted line) and dipole (dashed line) as in Fig 5. Above, the elevation-plane responses for the long-wire (solid line) and the dipole (dashed line) by themselves. Note that the elevation angle giving peak gain for each antenna is just about the same. The long-wire achieves gain by compressing mainly the azimuthal response, squeezing the gain into narrow lobes; not so much by squeezing the elevation pattern for gain.**



**Fig 7—The azimuthal-plane performance for an 8- $\lambda$  (571 feet) long-wire antenna (solid line), compared with a 4-element Yagi (dotted line) and a  $\frac{1}{2}$ - $\lambda$  dipole (dashed line).**

where  $N$  is the antenna length in wavelengths. In cases where precise resonance is desired for some reason (for obtaining a resistive load for a transmission line at a particular frequency, for example) it is best established by trimming the wire length until the standing-wave ratio on the line is minimum.

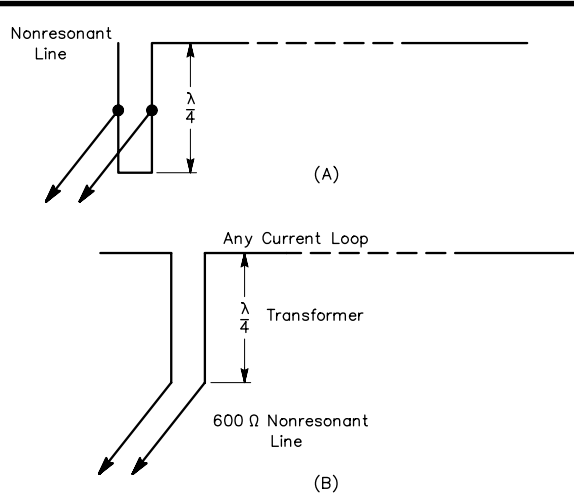
### Tilted Wires

In theory, it is possible to maximize gain from a long-wire antenna by tilting it to favor a desired elevation take-off angle. Unfortunately, the effect of real ground under the antenna negates the possible advantages of tilting, just as it does when a Yagi or other type of parasitic array is tilted from horizontal. You would do better keeping a long-wire antenna horizontal, but raising it higher above ground, to achieve more gain at low takeoff angles.

### Feeding Long Wires

A long-wire antenna is normally fed at the end or at a current loop. Since a current loop changes to a node when the antenna is operated at any even multiple of the frequency for which it is designed, a long-wire antenna will operate as a true long wire on all bands only when it is fed at the end.

A common method of feeding a long-wire is to use a resonant open-wire line. This system will work on all bands down to the one, if any, at which the antenna is only a half wave long. Any convenient line length can be used if you match the transmitter to the line's input impedance using an antenna tuner, as described in [Chapter 25](#).



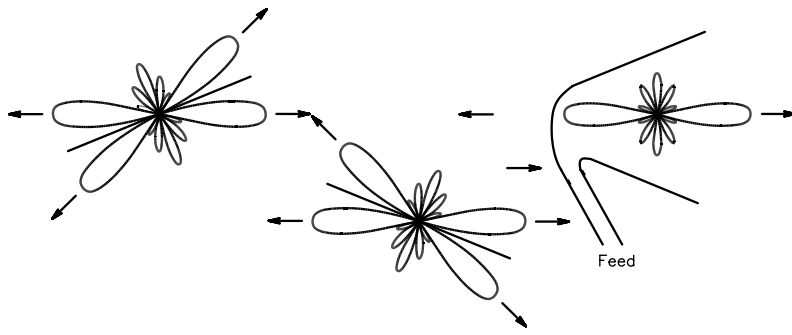
**Fig 8—Methods for feeding long single-wire antennas.**

Two arrangements for using nonresonant lines are given in [Fig 8](#). The one at A is useful for one band only since the matching section must be a quarter wave long, approximately, unless a different matching section is used for each band. In B, the  $\lambda/4$  transformer (Q-section) impedance can be designed to match the antenna to the line, as described in [Chapter 26](#). You can determine the value of radiation resistance using a modern modeling program or you can actually measure the feed-point impedance. Although it will work as designed on only one band, the antenna can be used on other bands by treating the line and matching transformer as a resonant line. In this case, as mentioned earlier, the antenna will not radiate as a true long wire on even multiples of the frequency for which the matching system is designed.

The end-fed arrangement, although the most convenient when tuned feeders are used, suffers the disadvantage that there is likely to be a considerable antenna current on the line. In addition, the antenna reactance changes rapidly with frequency. Consequently, when the wire is several wavelengths long, a relatively small change in frequency—a fraction of the width of a band—may require major changes in the adjustment of the antenna tuner. Also, the line becomes unbalanced at all frequencies between those at which the antenna is resonant. This leads to a considerable amount of radiation from the line. The unbalance can be overcome by using multiple long wires in a V or rhombic shape, as described below.

### COMBINATIONS OF LONG WIRES

The directivity and gain of long wires may be increased by using two wires placed in relation to each other such that the fields from both combine to produce the greatest possible field strength at a distant point. The principle is similar to that used in designing the multielement arrays described in [Chapter 8](#).



**Fig 9—Two long wires and their respective patterns are shown at the left. If these two wires are combined to form a V with an angle that is twice that of the major lobes of the wires and with the wires excited out of phase, the radiation along the bisector of the V adds and the radiation in the other directions tends to cancel.**

### Parallel Wires

One possible method of using two (or more) long wires is to place them in parallel, with a spacing of  $\frac{1}{2} \lambda$  or so, and feed the two in phase. In the direction of the wires the fields will add in phase. However, the takeoff angle is high directly in the orientation of the wire, and this method will result in rather high-angle radiation even if the wires are several wavelengths long. With a parallel arrangement of this sort the gain should be about 3 dB over a single wire of the same length, at spacings in the vicinity of  $\frac{1}{2}$  wavelength.

### The V-Beam Antenna

Instead of using two long wires parallel to each other, they may be placed in the form of a horizontal V, with the

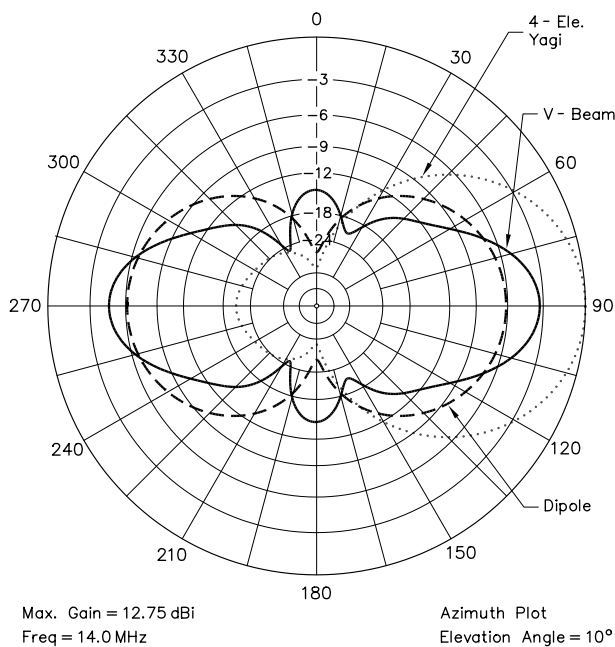
included angle between the wires equal to twice the angle made by the main lobes referenced to the wire axis for a single wire of the same physical length. For example, for a leg length of  $5 \lambda$ , the angle between the legs of a V should be about  $42^\circ$ , twice the angle of  $21^\circ$  of the main lobe referenced to the long-wire's axis. See Fig 6A.

The plane directive patterns of the individual wires combine along a line in the plane of the antenna and bisecting the V, where the fields from the individual wires reinforce each other. The sidelobes in the azimuthal pattern are suppressed by about 10 dB, so the pattern becomes essentially bidirectional. See Fig 9.

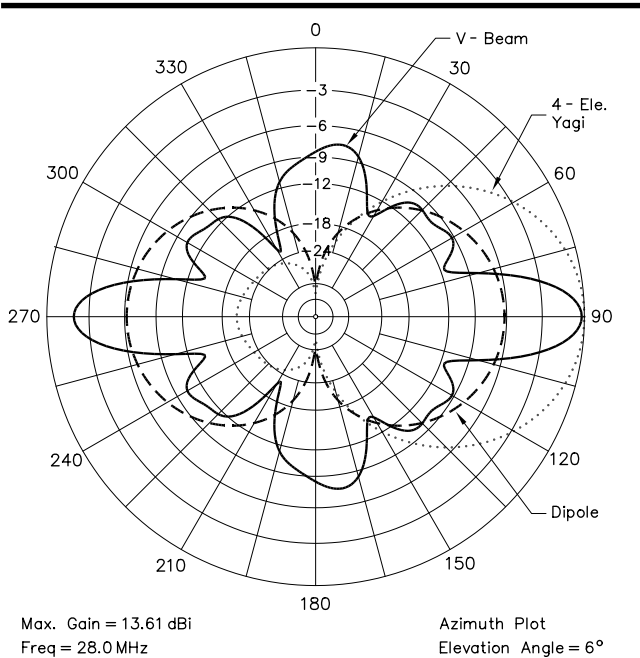
The included angle between the legs is not particularly critical. This is fortunate, especially if the same antenna is used on multiple bands, where the electrical length varies directly with frequency. This would normally require different included angles for each band. For multiband V-antennas, a compromise angle is usually chosen to equalize performance. Fig 10 shows the azimuthal pattern for a V-beam with  $1\text{-}\lambda$  legs, with an included angle of  $75^\circ$  between the legs, mounted  $1 \lambda$  above flat ground. This is for a  $10^\circ$  elevation angle. At 14 MHz the antenna has two 70-foot high, 68.5-foot long legs, separated at their far ends by 83.4 feet. For comparison the azimuthal patterns for the same 4-element Yagi and  $\frac{1}{2}\text{-}\lambda$  dipole used previously for the long-wires are overlaid on the same plot. The V has about 2 dB more gain than the dipole but is down some 4 dB compared to the Yagi, as expected for relatively short legs.

Fig 11 shows the azimuthal pattern for the same antenna in Fig 10, but at 28 MHz and at an elevation angle of  $6^\circ$ . Because the legs are twice as long electrically at 28 MHz, the V-beam has compressed the main lobe into a narrow beam that now has a peak gain equal to the Yagi, but with a 3-dB beamwidth of only  $18.8^\circ$ . Note that you could obtain about 0.7 dB more gain at 14 MHz, with a 1.7-dB degradation of gain at 28 MHz, if you increase the included angle to  $90^\circ$  rather than  $75^\circ$ .

Fig 12 shows the azimuthal pattern for a V-beam with  $2\text{-}\lambda$  legs (137 feet at 14 MHz), with an included angle of  $60^\circ$  between them. As usual, the assumed height is 70 feet, or  $1 \lambda$  at 14 MHz. The peak gain for the V-beam is just about equal to that of the 4-element Yagi, although the 3-dB nose beamwidth is narrow, at  $23^\circ$ . This makes setting up the



**Fig 10—Azimuthal-plane pattern at  $10^\circ$  elevation angle for a 14-MHz V-beam (solid line) with  $1\text{-}\lambda$  legs (68.5 feet long), using an included angle of  $75^\circ$  between the legs. The V-beam is mounted  $1 \lambda$  above flat ground, and is compared with a  $\frac{1}{2}\text{-}\lambda$  dipole (dashed line) and a 4-element 20-meter Yagi on a 26-foot boom (dotted line).**



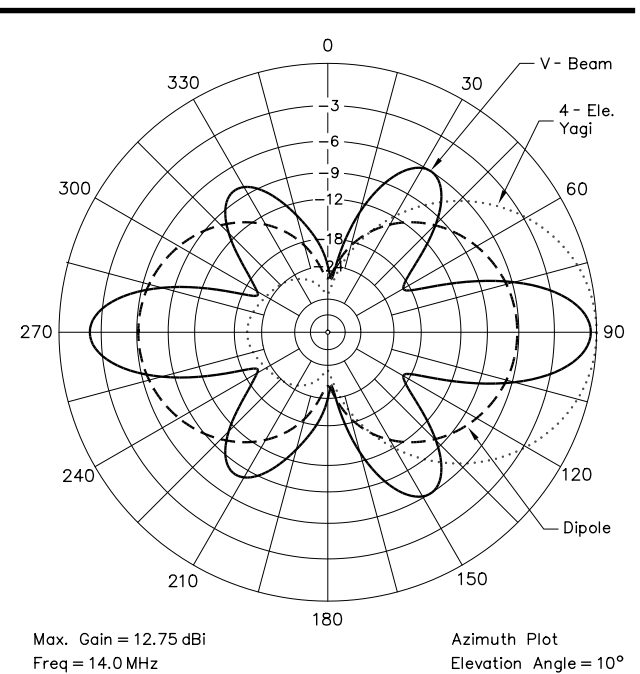
**Fig 11**—The same V-beam as in Fig 10 at 28 MHz (solid line), at an elevation angle of 6°, compared to a 4-element Yagi (dotted line) and a dipole (dashed line). The V-beam’s pattern is very narrow, at 18.8° at the 3-dB points, requiring accurate placement of the supports poles to aim the antenna at the desired geographic target.

geometry critical if you want to maximize gain into a particular geographic area. While you might be able to get away with using convenient trees to support such an antenna, it’s far more likely that you’ll have to use carefully located towers to make sure the beam is aimed where you expect it to be pointed.

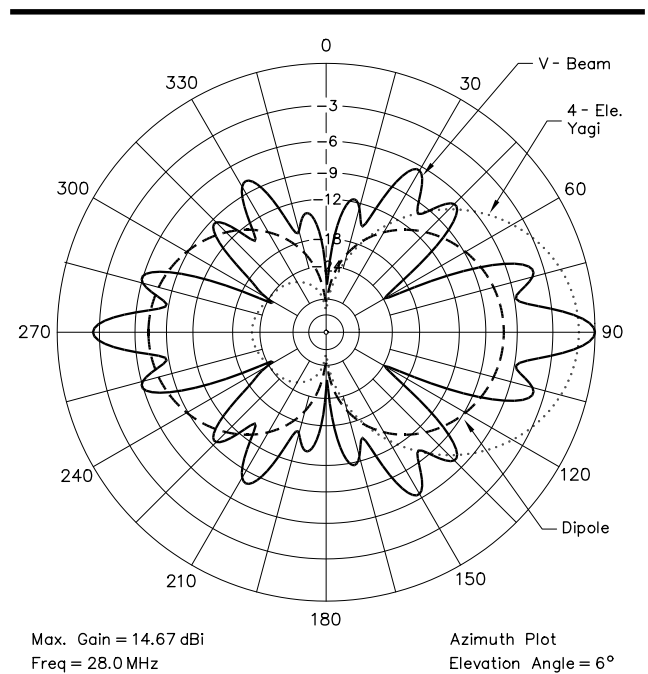
For example, in order to cover all of Europe from San Francisco, an antenna must cover from about 11° (to Moscow) to about 46° (to Portugal). This is a range of 35° and signals from the V-beam in Fig 12 would be down some 7 dB over this range of angles, assuming the center of the beam is pointed exactly at a heading of 28.5°. The 4-element Yagi on the other hand would cover this range of azimuths more consistently, since its 3-dB beamwidth is 63°.

**Fig 13** shows the same V-beam as in Fig 12, but this time at 28 MHz. The peak gain of the main lobe is now about 1 dB stronger than the 4-element Yagi used as a reference, and the main lobe has two nearby sidelobes that tend to broaden out the azimuthal response. At this frequency the V-beam would cover all of Europe better from San Francisco.

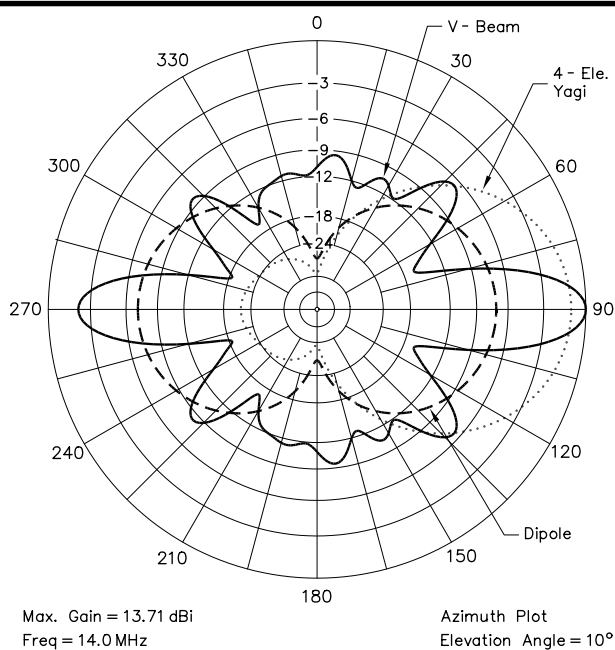
**Fig 14** shows a V-beam with 3-λ (209 feet at 14 MHz) legs with an included angle of 50° between them. The peak gain is now greater than that of a 4-element Yagi, but the 3-dB beamwidth has been reduced to 17.8°, making aiming the antenna even more critical. **Fig 15** shows the same V-beam at 28 MHz. Here again, the main lobe has nearby sidelobes that broaden the effective azimuth to cover a wider area.



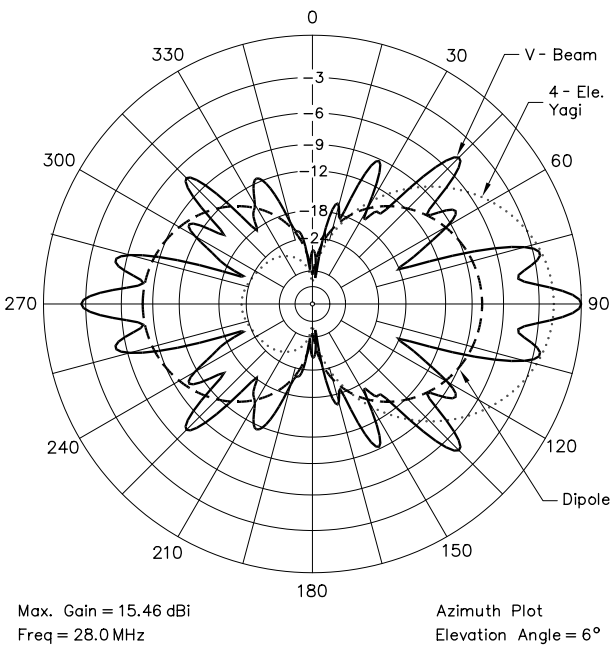
**Fig 12**—Azimuthal pattern for a V-beam (solid line) with 2-λ legs (137 feet at 14 MHz), with an included angle of 60° between them. The height is 70 feet, or 1 λ, over flat ground. For comparison, the response for a 4-element Yagi (dotted line) and a dipole (dashed line) are shown. The 3-dB beamwidth has decreased to 23.0°.



**Fig 13**—The same 2-λ per leg V-beam (solid line) as in Fig 12, but at 28 MHz and at a 6° takeoff elevation angle. Two sidelobes have appeared flanking the main lobe, making the effective azimuthal pattern wider at this frequency.

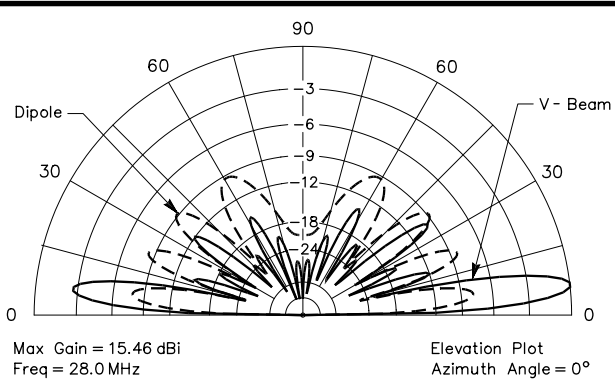


**Fig 14—A V-beam (solid line) with  $3\lambda$  (209 feet at 14 MHz) legs using an included angle of  $50^\circ$  between them, compared to a 4-element Yagi (dotted line) and a dipole (dashed line). The 3-dB beamwidth has now decreased to  $17.8^\circ$ .**

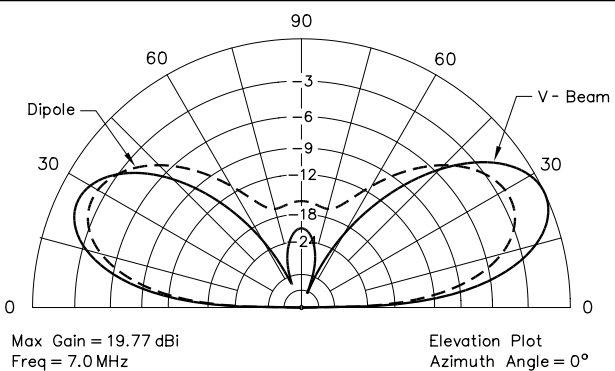


**Fig 15—The same 209-foot/leg V-beam as Fig 14, but at 28 MHz. Again, the two close-in sidelobes tend to spread out the azimuthal response some at 28 MHz.**

**Fig 16** shows the elevation-plane response for the same 209-foot leg V-beam at 28 MHz ( $3\lambda$  at 14 MHz), compared to a dipole at the same height of 70 feet. The higher-gain V-beam suppresses higher-angle lobes, essentially stealing



**Fig 16—The elevation-plane of the 209-foot/leg V-beam (solid line) compared to the dipole (dashed line). Again, the elevation angle for peak gain corresponds well to that of the simple dipole at the same height.**



**Fig 17—Elevation pattern for the same 209-foot-per-leg V-beam (solid line), at 7 MHz, compared to a 40-meter dipole (dashed line) at the same height of 70 feet.**

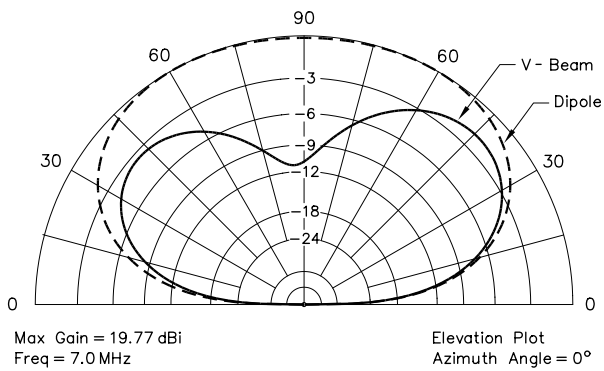
energy from them and concentrating it in the main beam at  $6^\circ$  elevation.

The same antenna can be used at 3.5 and 7 MHz. The gain will not be large, however, because the legs are not very long at these frequencies. **Fig 17** compares the V-beam versus a horizontal  $\frac{1}{2}\lambda$  40-meter dipole at 70 feet. At low elevation angles there is about 2 dB of advantage on 40 meters. **Fig 18** shows the same type of comparison for 80 meters, where the 80-meter dipole is superior at all angles.

### Other V Combinations

A gain increase of about 3 dB can be had by stacking two V-beams one above the other, a half wavelength apart, and feeding them with in-phase currents. This will result in a lowered angle of radiation. The bottom V should be at least a quarter wavelength above the ground, and preferably a half wavelength. This arrangement will narrow the elevation pattern and it will also have a narrow azimuthal pattern.

The V antenna can be made unidirectional by using a second V placed an odd multiple of a quarter wavelength in back of the first and exciting the two with a phase difference



**Fig 18—Elevation pattern for the same 209-foot-per-leg V-beam (solid line), at 3.5 MHz, compared to an 80-meter dipole at 70 feet (dashed line).**

of 90°. The system will be unidirectional in the direction of the antenna with the lagging current. However, the V reflector is not normally employed by amateurs at low frequencies because it restricts the use to one band and requires a fairly elaborate supporting structure. Stacked Vs with driven reflectors could, however, be built for the 200- to 500-MHz region without much difficulty.

### Feeding the V Beam

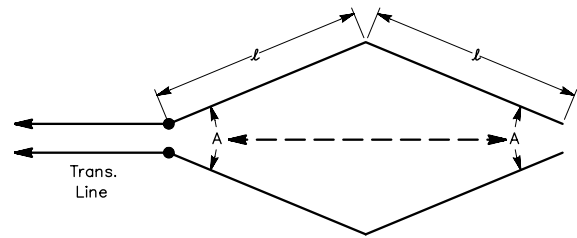
The V-beam antenna is most conveniently fed with tuned open-wire feeders with an antenna tuner, since this permits multiband operation. Although the length of the wires in a V-beam is not at all critical, it is important that both wires be the same electrical length. If the use of a nonresonant line is desired, probably the most appropriate matching system is that using a stub or quarter-wave matching section. The adjustment of such a system is described in [Chapter 26](#).

### THE RESONANT RHOMBIC ANTENNA

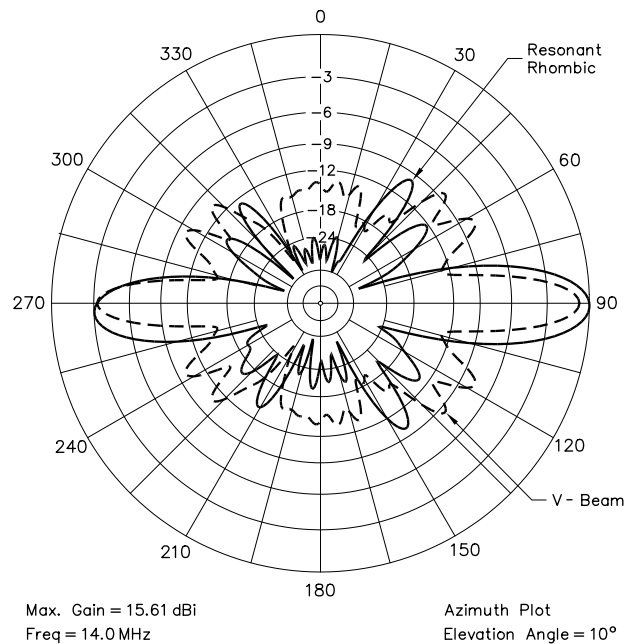
The diamond-shaped or rhombic antenna shown in [Fig 19](#) can be looked upon as two acute-angle V-beams placed end-to-end. This arrangement is called a *resonant rhombic*. The leg lengths of the resonant rhombic must be an integral number of half wavelengths to avoid reactance at its feed point.

The resonant rhombic has two advantages over the simple V-beam. For the same total wire length it gives somewhat greater gain than the V-beam. A rhombic with  $3\lambda$  on a leg, for example, has about 1 dB gain over a V antenna with 6 wavelengths on a leg. [Fig 20](#) compares the azimuthal pattern at a 10° elevation for a resonant rhombic with  $3\lambda$  legs on 14 MHz, compared to a V-beam with 6  $\lambda$  legs at the same height of 70 feet. The 3-dB nose beamwidth of the resonant rhombic is only 12.4° wide, but the gain is very high at 16.26 dBi.

The directional pattern of the rhombic is less frequency sensitive than the V when the antenna is used over a wide



**Fig 19—The resonant rhombic or diamond-shaped antenna. All legs are the same length, and opposite angles of the diamond are equal. Length  $\ell$  is an integral number of half wavelengths for resonance.**



**Fig 20—Azimuthal-plane pattern of resonant (underterminated) rhombic (solid line) with  $3\lambda$  legs on 14 MHz, at a height of 70 feet above flat ground, compared with a 6- $\lambda$  per leg V-beam (dashed line) at the same height. Both azimuthal patterns are at a takeoff angle of 10°. The sidelobes for the resonant rhombic are suppressed to a greater degree than those for the V-beam.**

frequency range. This is because a change in frequency causes the major lobe from one leg to shift in one direction while the lobe from the opposite leg shifts the other way. This automatic compensation keeps the direction the same over a considerable frequency range. The disadvantage of the rhombic as compared with the V-beam is that an additional support is required.

The same factors that govern the design of the V-beam apply in the case of the resonant rhombic. The optimal apex angle  $A$  in [Fig 19](#) is the same as that for a V having an equal leg length. The diamond-shaped antenna also can be operated

as a terminated antenna, as described later in this chapter, and much of the discussion in that section applies to the resonant rhombic as well.

The resonant rhombic has a bidirectional pattern, with minor lobes in other directions, their number and intensity depending on the leg length. In general, these sidelobes are suppressed better with a resonant rhombic than with a V-beam. When used at frequencies below the VHF region, the rhombic antenna is always mounted with the plane containing the wires horizontal. The polarization in this plane, and also in the perpendicular plane that bisects the rhombic, is horizontal. At 144 MHz and above, the dimensions are such that the antenna can be mounted with the plane containing the wires vertical if vertical polarization is desired.

When the rhombic antenna is to be used on several HF amateur bands, it is advisable to choose the apex angle,  $A$ , on the basis of the leg length in wavelengths at 14 MHz. Although the gain on higher frequency bands will not be quite as favorable as if the antenna had been designed for the higher frequencies, the system will still work well at the low angles that are necessary at such frequencies.

The resonant rhombic has lots of gain, but you must not forget that this gain comes from a radiation pattern that is very narrow. This requires careful placement of the supports for the resonant rhombic to cover desired geographic areas. This is definitely not an antenna that allows you to use just any convenient trees as supports!

The resonant rhombic antenna can be fed in the same way as the V-beam. Resonant feeders are necessary if the antenna is to be used in several amateur bands.

### TERMINATED LONG-WIRE ANTENNAS

All the antenna systems considered so far in this chapter have been based on operation with standing waves of current and voltage along the wire. Although most hams use antenna designs based on using resonant wires, resonance is by no means a necessary condition for the wire to radiate and intercept electromagnetic waves efficiently, as discussed in Chapter 2. The result of using nonresonant wires is reactance at the feed point, unless the antenna is terminated with a resistive load.

In Fig 21, suppose that the wire is parallel with the ground (horizontal) and is terminated by a load  $Z$  equal to its characteristic impedance,  $Z_{ANT}$ . The wire and its image in the ground create a transmission line. The load  $Z$  can represent a receiver matched to the line. The terminating resistor  $R$  is also equal to the  $Z_{ANT}$  of the wire. A wave coming from direction  $X$  will strike the wire first at its far end and sweep across the wire at some angle until it reaches the end at which  $Z$  is connected. In so doing, it will induce voltages in the antenna, and currents will flow as a result. The current flowing toward  $Z$  is the useful output of the antenna, while the current flowing backwards toward  $R$  will be absorbed in  $R$ . The same thing is true of a wave coming from the direction  $X'$ . In such an antenna there are no standing waves, because all received power is absorbed at either end.

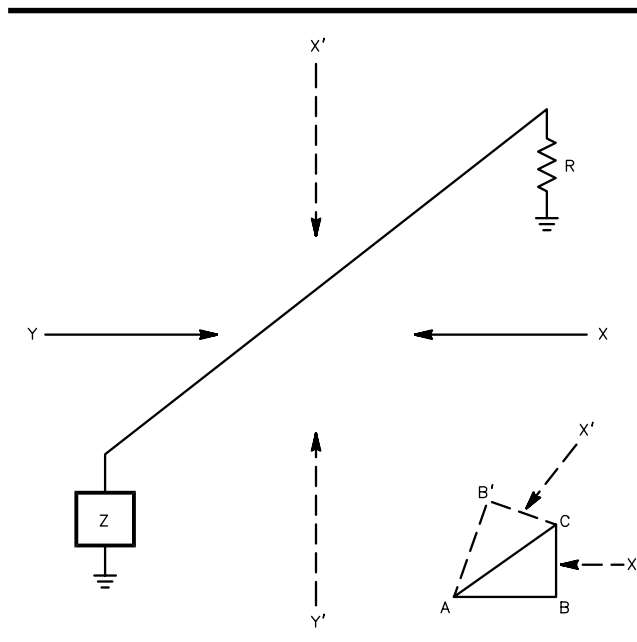


Fig 21—Layout for a terminated long-wire antenna.

The greatest possible power will be delivered to the load  $Z$  when the individual currents induced as the wave sweeps across the wire all combine properly on reaching the load. The currents will reach  $Z$  in optimum phase when the time required for a current to flow from the far end of the antenna to  $Z$  is exactly one-half cycle longer than the time taken by the wave to sweep over the antenna. A half cycle is equivalent to a half wavelength greater than the distance traversed by the wave from the instant it strikes the far end of the antenna to the instant that it reaches the near end. This is shown by the small drawing, where  $AC$  represents the antenna,  $BC$  is a line perpendicular to the wave direction, and  $AB$  is the distance traveled by the wave in sweeping past  $AC$ .  $AB$  must be one-half wavelength shorter than  $AC$ . Similarly,  $AB'$  must be the same length as  $AB$  for a wave arriving from  $X'$ .

A wave arriving at the antenna from the opposite direction  $Y$  (or  $Y'$ ), will similarly result in the largest possible current at the far end. However, since the far end is terminated in  $R$ , which is equal to  $Z$ , all the power delivered to  $R$  by the wave arriving from  $Y$  will be absorbed in  $R$ . The current traveling to  $Z$  will produce a signal in  $Z$  in proportion to its amplitude. If the antenna length is such that all the individual currents arrive at  $Z$  in such phase as to add up to zero, there will be no current through  $Z$ . At other lengths the resultant current may reach appreciable values. The lengths that give zero amplitude are those which are odd multiples of  $1/4 \lambda$ , beginning at  $3/4 \lambda$ . The response from the  $Y$  direction is greatest when the antenna is any even multiple of  $1/2 \lambda$  long; the higher the multiple, the smaller the response.



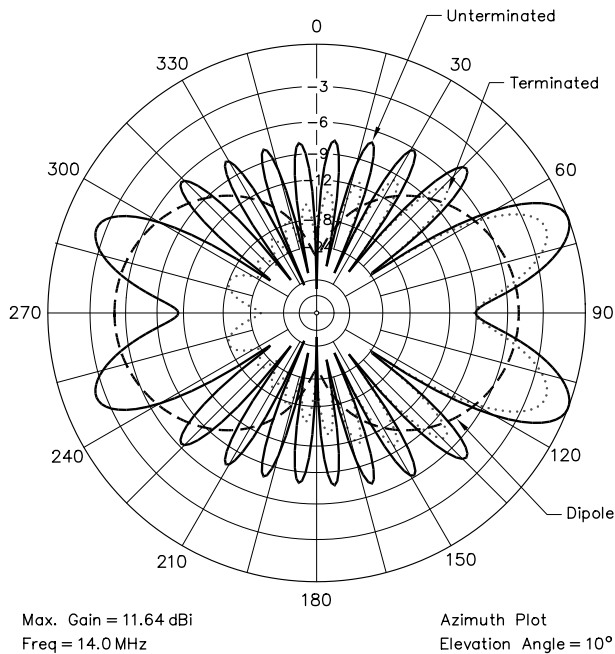
## Directional Characteristics

**Fig 22** compares the azimuthal pattern for a  $5\text{-}\lambda$  long 14-MHz long-wire antenna, 70 feet high over flat ground, when it is terminated and when it is unterminated. The rearward pattern when the wire is terminated with a  $600\ \Omega$  resistor is reduced about 15 dB, with a reduction in gain in the forward direction of about 2 dB.

For a shorter leg length in a terminated long-wire antenna, the reduction in forward gain is larger—more energy is radiated by a longer wire before the forward wave is absorbed in the terminating resistor. The azimuthal patterns for terminated and unterminated V-beams with  $2\text{-}\lambda$  legs are overlaid for comparison in **Fig 23**. With these relatively short legs the reduction in forward gain is about 3.5 dB due to the terminations, although the front-to-rear ratio approaches 20 dB for the terminated V-beam. Each leg of this terminated V-beam use a  $600\text{-}\Omega$  non-inductive resistor to ground. Each resistor would have to dissipate about one-quarter of the transmitter power. For average conductor diameters and heights above ground, the  $Z_{\text{ANT}}$  of the antenna is of the order of 500 to  $600\ \Omega$ .

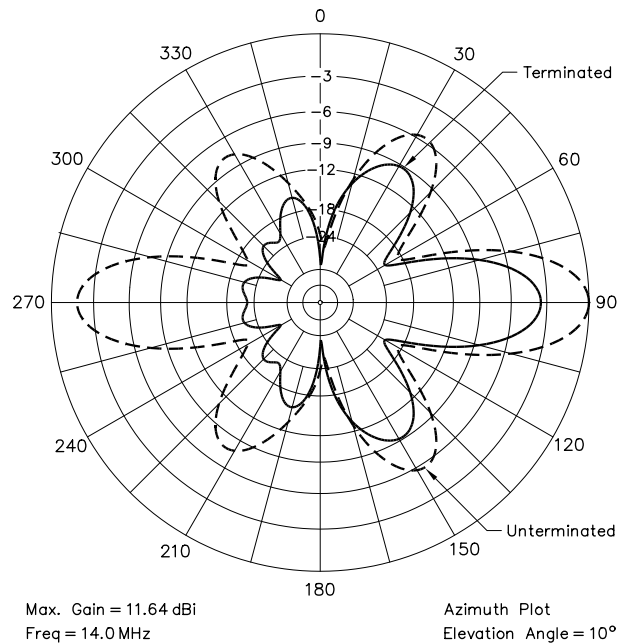
### THE TERMINATED RHOMBIC ANTENNA

The highest development of the long-wire antenna is the *terminated rhombic*, shown schematically in **Fig 24**. It

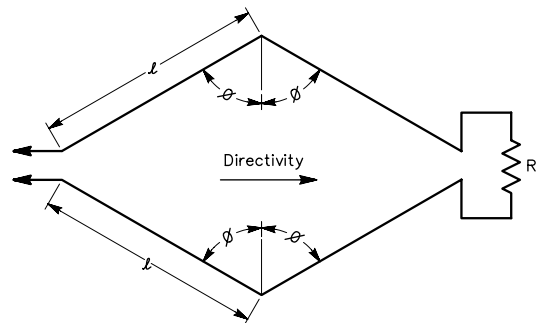


**Fig 22**—Azimuthal-plane pattern for  $5\text{-}\lambda$  long-wire antenna at 14 MHz and 70 feet above flat ground. The solid line shows the long-wire terminated with  $600\text{-}\Omega$  to ground, while the dashed line is for the same antenna unterminated. For comparison, the response for a  $1/2\text{-}\lambda$  dipole is overlaid with the two other patterns. You can see that the terminated long-wire has a good front-to-back pattern, but it loses about 2 dB in forward gain compared to the unterminated long-wire.

consists of four conductors joined to form a diamond, or *rhombus*. All sides of the antenna have the same length and the opposite corner angles are equal. The antenna can be considered as being made up of two V antennas placed end to end and terminated by a noninductive resistor to produce a unidirectional pattern. The terminating resistor is connected between the far ends of the two sides, and is made approximately equal to the characteristic impedance of the antenna as a unit. The rhombic may be constructed either horizontally or vertically, but is practically always constructed horizontally at frequencies below 54 MHz, since



**Fig 23**—The azimuthal patterns for a shorter-leg V-beam ( $2\text{-}\lambda$  legs) when it is terminated (solid line) and unterminated (dashed line). With shorter legs, the terminated V-beam loses about 3.5 dB in forward gain compared to the unterminated version, while suppressing the rearward lobes as much as 20 dB.



**Fig 24**—The layout for a terminated rhombic antenna.

the pole height required is considerably less. Also, horizontal polarization is equally, if not more, satisfactory at these frequencies over most types of soil.

The basic principle of combining lobes of maximum radiation from the four individual wires constituting the rhombus or diamond is the same in either the terminated type or the resonant type described earlier in this chapter.

### Tilt Angle

In dealing with the terminated rhombic, it is a matter of custom to talk about the *tilt angle* ( $\phi$  in Fig 24), rather than the angle of maximum radiation with respect to an individual wire. Fig 25 shows the tilt angle as a function of the antenna leg length. The curve marked “0°” is used for a takeoff elevation angle of 0°; that is, maximum radiation in the plane of the antenna. The other curves show the proper tilt angles to use when aligning the major lobe with a desired takeoff angle. For a 5° takeoff angle, the difference in tilt angle is less than 1° for the range of lengths shown.

The broken curve marked “optimum length” shows the leg length at which maximum gain is obtained at any given takeoff angle. Increasing the leg length beyond the optimum will result in less gain, and for that reason the curves do not extend beyond the optimum length. Note that the optimum length becomes greater as the desired takeoff angle decreases. Leg lengths over  $6\lambda$  are not recommended because the directive pattern becomes so sharp that the antenna performance is highly variable with small changes in the angle, both horizontal and vertical, at which an incoming wave reaches the antenna. Since these angles vary to some extent in ionospheric propagation, it does not pay

to attempt to try for too great a degree of directivity.

### Multiband Design

When a rhombic antenna is to be used over a considerable frequency range, a compromise must be made in the tilt angle. Fig 26 gives the design dimensions of a suitable compromise for a rhombic that covers the 14 to 30 MHz range well. Fig 27A shows the azimuth and elevation patterns for this antenna at 14 MHz, at a height of 70 feet over flat ground. The comparison antenna in this case is a 4-element Yagi on a 26-foot boom, also 70 feet above flat ground. The rhombic has about 2.2 dB more gain, but its azimuthal pattern is 17.2° wide at the 3 dB points,

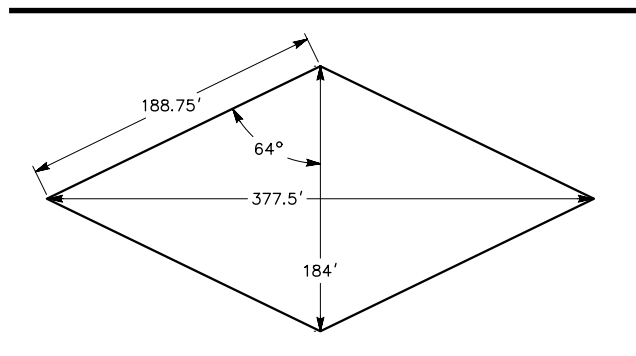


Fig 26—Rhombic antenna dimensions for a compromise design between 14- and 28-MHz requirements, as discussed in the text. The leg length is  $6\lambda$  at 28 MHz,  $3\lambda$  at 14 MHz.

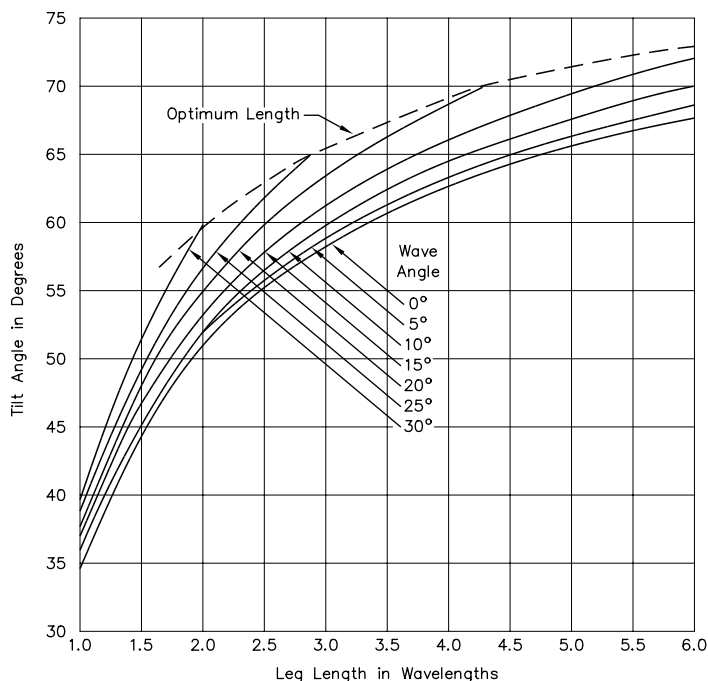
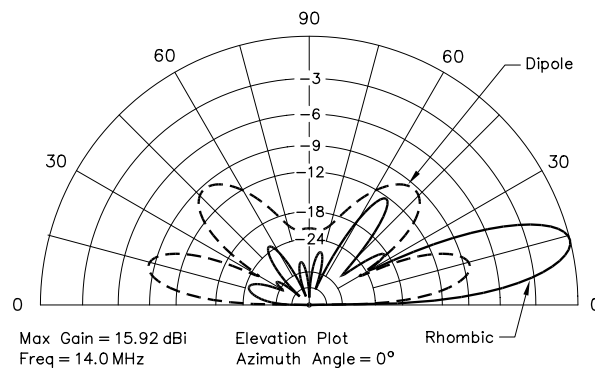
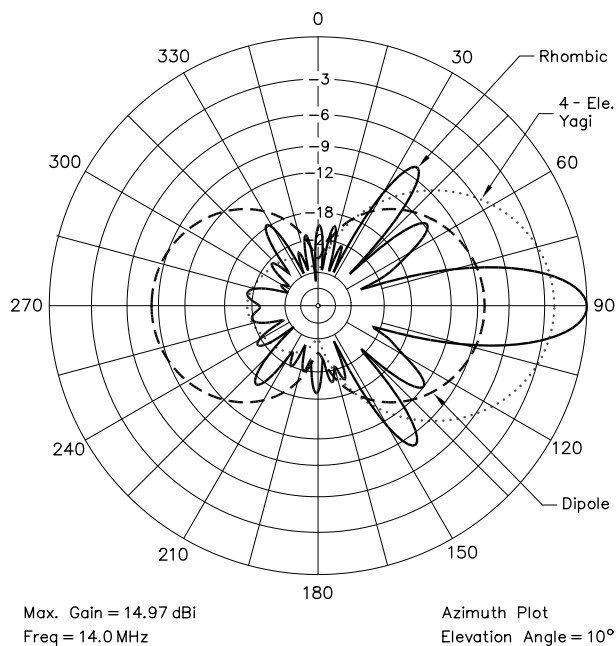


Fig 25—Rhombic-antenna design chart. For any given leg length, the curves show the proper tilt angle to give maximum radiation at the selected takeoff angle. The broken curve marked “optimum length” shows the leg length that gives the maximum possible output at the selected takeoff angle. The optimum length as given by the curves should be multiplied by 0.74 to obtain the leg length for which the takeoff angle and main lobe are aligned.



**Fig 27**—At left, azimuthal pattern for 3- $\lambda$  (at 14 MHz) terminated rhombic (solid line) shown in Fig 26, compared with 4-element 20-meter Yagi (dotted line) on a 26-foot boom and a 20-meter dipole (dashed line). All antennas are mounted 70 feet ( $1 \lambda$ ) above flat ground. The rearward pattern of the terminated rhombic is good and the forward gain exceeds that of the Yagi, but the frontal lobe is very narrow. Above, elevation-plane pattern of terminated rhombic compared to that of a simple dipole at the same height.

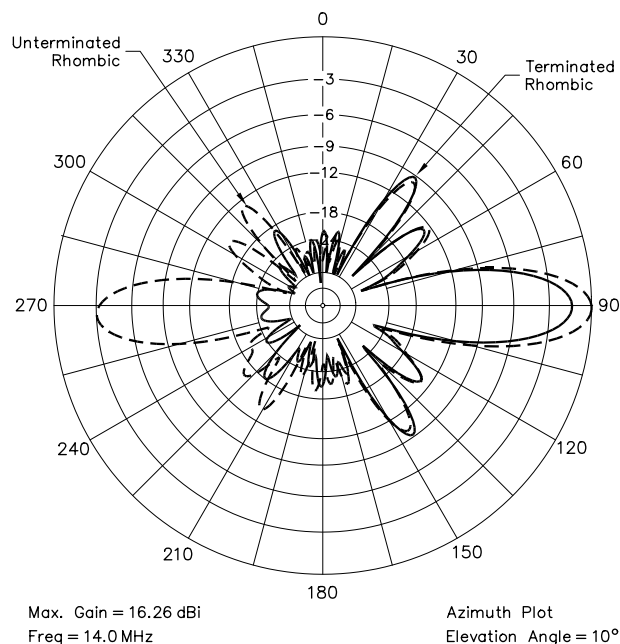
and only 26° at the -20 dB points! On the other hand, the Yagi has a 3-dB beamwidth of 63°, making it far easier to aim at a distant geographic location. Fig 27B shows the elevation-plane patterns for the same antennas above. As usual, the peak angle for either horizontally polarized antenna is determined mainly by the height above ground.

The peak gain of a terminated rhombic is less than that of an unterminated resonant rhombic. For the rhombic of Fig 26, the reduction in peak gain is about 1.5 dB. Fig 28 compares the azimuthal patterns for this rhombic with and without an 800- $\Omega$  termination.

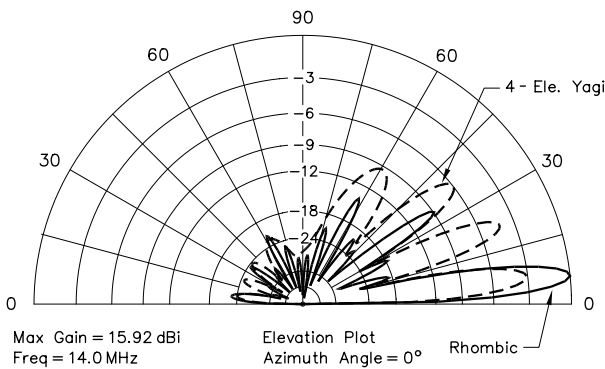
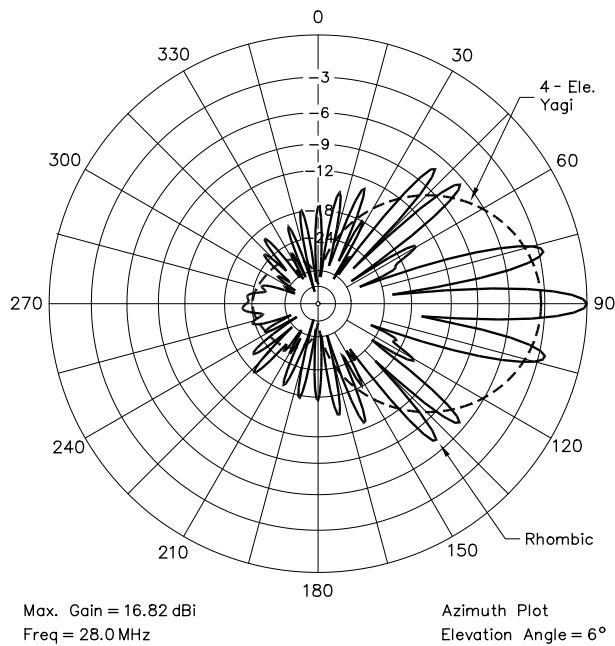
Fig 29 shows the azimuth and elevation patterns for the terminated rhombic of Fig 26 when it is operated at 28 MHz. The main lobe becomes very narrow, at 6.9° at the 3-dB points. However, this is partially compensated for by the appearance of two sidelobes each side of the main beam. These tend to spread out the main pattern some. Again, a 4-element Yagi at the same height is used for comparison.

### Termination

Although the difference in the gain is relatively small with terminated or unterminated rhombics of comparable design, the terminated antenna has the advantage that over a wide frequency range it presents an essentially resistive and constant load to the transmitter. In a sense, the power dissipated in the terminating resistor can be considered power that would have been radiated in the other direction had the resistor not been there. Therefore, the fact that some of the power (about one-third) is used up in heating the resistor does



**Fig 28**— Comparison of azimuthal patterns for terminated (solid line) and unterminated (dashed line) rhombic antennas, using same dimensions as Fig 26 at a frequency of 14 MHz. The gain tradeoff is about 1.5 dB in return for the superior rearward pattern of the terminated antenna.



**Fig 29—At A, the azimuthal pattern for the same terminated antenna in Fig 26, but now at 28 MHz compared to a 4-element 10-meter Yagi . At B, the elevation-plane pattern comparison for these antennas.**

not mean that much actual loss in the desired direction.

The characteristic impedance of an ordinary rhombic antenna, looking into the input end, is in the order of 700 to 800  $\Omega$  when properly terminated in a resistance at the far end. The terminating resistance required to bring about the matching condition usually is slightly higher than the input impedance because of the loss of energy through radiation by the time the far end is reached. The correct value usually will be found to be of the order of 800  $\Omega$ , and should be determined experimentally if the flattest possible antenna is desired. However, for average work a noninductive resistance of 800  $\Omega$  can be used with the assurance that the operation will not be far from optimum.

The terminating resistor must be practically a pure resistance at the operating frequencies; that is, its inductance

and capacitance should be negligible. Ordinary wire-wound resistors are not suitable because they have far too much inductance and distributed capacitance. Small carbon resistors have satisfactory electrical characteristics but will not dissipate more than a few watts and so cannot be used, except when the transmitter power does not exceed 10 or 20 watts or when the antenna is to be used for reception only. The special resistors designed either for use as dummy antennas or for terminating rhombic antennas should be used in other cases. To allow a factor of safety, the total rated power dissipation of the resistor or resistors should be equal to half the power output of the transmitter.

To reduce the effects of stray capacitance it is desirable to use several units, say three, in series even when one alone will safely dissipate the power. The two end units should be identical and each should have one fourth to one third the total resistance, with the center unit making up the difference. The units should be installed in a weatherproof housing at the end of the antenna to protect them and to permit mounting without mechanical strain. The connecting leads should be short so that little extraneous inductance is introduced.

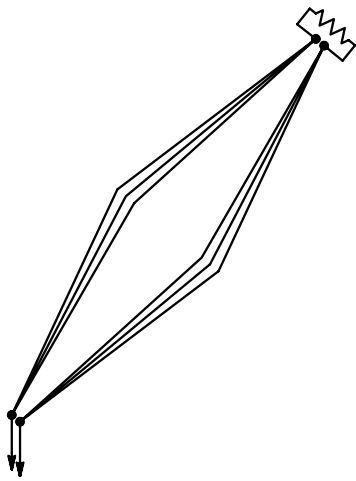
Alternatively, the terminating resistance may be placed at the end of an 800- $\Omega$  line connected to the end of the antenna. This will permit placing the resistors and their housing at a point convenient for adjustment rather than at the top of the pole. Resistance wire may be used for this line, so that a portion of the power will be dissipated before it reaches the resistive termination, thus permitting the use of lower wattage lumped resistors.

### Multiwire Rhombics

The input impedance of a rhombic antenna constructed as in Fig 26 is not quite constant as the frequency is varied. This is because the varying separation between the wires causes the characteristic impedance of the antenna to vary along its length. The variation in  $Z_{ANT}$  can be minimized by a conductor arrangement that increases the capacitance per unit length in proportion to the separation between the wires.

The method of accomplishing this is shown in Fig 30. Three conductors are used, joined together at the ends but with increasing separation as the junction between legs is approached. For HF work the spacing between the wires at the center is 3 to 4 feet, which is similar to that used in commercial installations using legs several wavelengths long. Since all three wires should have the same length, the top and bottom wires should be slightly farther from the support than the middle wire. Using three wires in this way reduces the  $Z_{ANT}$  of the antenna to approximately 600  $\Omega$ , thus providing a better match for practical open-wire line, in addition to smoothing out the impedance variation over the frequency range.

A similar effect (although not quite as favorable) is obtained by using two wires instead of three. The 3-wire system has been found to increase the gain of the antenna by about 1 dB over that of a single-conductor version.



**Fig 30—Three-wire rhombic antenna. Use of multiple wires improves the impedance characteristic of a terminated rhombic and increases the gain somewhat.**

### Front-to-Back Ratio

It is theoretically possible to obtain an infinite front-to-back ratio with a terminated rhombic antenna, and in practice very large values can be had. However, when the antenna is terminated in its characteristic impedance, the infinite front-to-back ratio can be obtained only at frequencies for which the leg length is an odd multiple of a quarter wavelength. The front-to-back ratio is smallest at frequencies for which the leg length is a multiple of a half wavelength.

When the leg length is not an odd multiple of a quarter wave at the frequency under consideration, the front-to-back ratio can be made very high by decreasing the value of terminating resistance slightly. This permits a small reflection from the far end of the antenna, which cancels out the residual response at the input end. With large antennas, the front-to-back ratio may be made very large over the whole frequency range by experimental adjustment of the terminating resistance. Modification of the terminating resistance can result in a splitting of the back null into two nulls, one on either side of a small lobe in the back direction. Changes in the value of terminating resistance thus permit steering the back null over a small horizontal range so that signals coming from a particular spot not exactly to the rear of the antenna may be minimized.

### Methods of Feed

If the broad frequency characteristic of the terminated rhombic antenna is to be utilized fully, the feeder system must be similarly broadbanded. Open-wire transmission line of the same characteristic impedance as that shown at the antenna input terminals (approximately 700 to 800  $\Omega$ ) may be used. Data for the construction of such lines is given in [Chapter 24](#). While the usual matching stub can be used to provide an impedance transformation to more satisfactory line impedances, this limits the operation of the antenna to a comparatively narrow range of frequencies centering about that for which the stub is adjusted. Probably a more satisfactory arrangement would be to use a coaxial transmission line and a broadband transformer balun at the antenna feed point.

## Receiving Wave Antennas

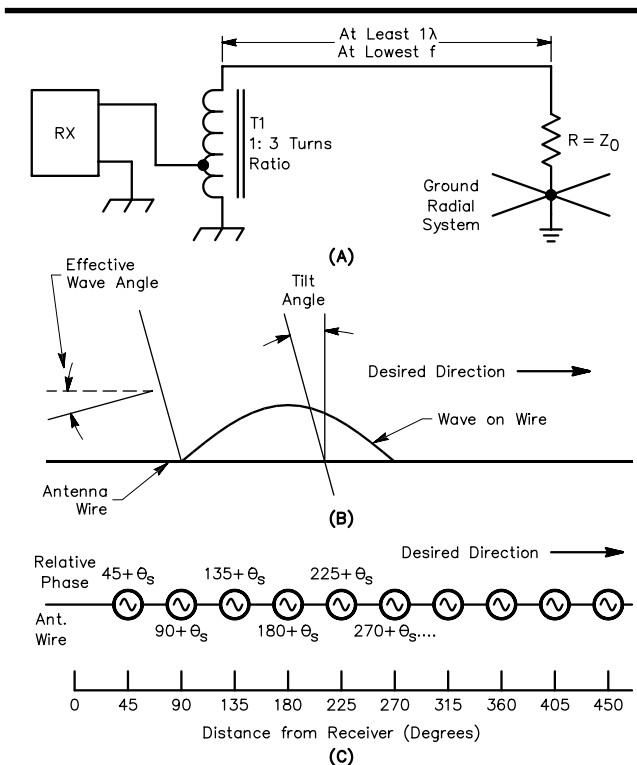
Perhaps the best known type of wave antenna is the *Beverage*. Many 160-meter enthusiasts have used Beverage antennas to enhance the signal-to-noise ratio while attempting to extract weak signals from the often high levels of atmospheric noise and interference on the low bands. Alternative antenna systems have been developed and used over the years, such as loops and long spans of unterminated wire on or slightly above the ground, but the Beverage antenna seems to be the best for 160-meter weak-signal reception. The information in this section was prepared originally by Rus Healy, K2UA (ex-NJ2L).

### THE BEVERAGE ANTENNA

A Beverage is simply a directional wire antenna, at least one wavelength long, supported along its length at a fairly low height and terminated at the far end in its characteristic impedance. This antenna is shown in [Fig 31A](#). It takes its name from its inventor, Harold Beverage, W2BML.

Many amateurs choose to use a single-wire Beverage because they are easy to install and they work well. The drawback is that Beverages are physically long and they do require that you have the necessary amount of real estate to install them. Sometimes, a neighbor will allow you to put up a temporary Beverage for a particular contest or DXpedition on his land, particularly during the winter months.

Beverage antennas can be useful into the HF range, but they are most effective at lower frequencies, mainly on 160 through 40 meters. The antenna is responsive mostly to low-angle incoming waves that maintain a constant (vertical) polarization. These conditions are nearly always satisfied on 160 meters, and most of the time on 80 meters. As the frequency is increased, however, the polarization and arrival angles are less and less constant and favorable, making Beverages less effective at these frequencies. Many amateurs have, however, reported excellent performance from Beverage antennas at frequencies as high as 14 MHz, especially when rain or snow (precipitation) static prevents



**Fig 31—At A, a simple one-wire Beverage antenna with a variable termination impedance and a matching 9:1 autotransformer for the receiver impedance. At B, a portion of a wave from the desired direction is shown traveling down the antenna wire. Its tilt angle and effective wave angle are also shown. At C, a situation analogous to the action of a Beverage on an incoming wave is shown. See text for discussion.**

good reception on the Yagi or dipole transmitting antennas used on the higher frequencies.

### Beverage Theory

The Beverage antenna acts like a long transmission line with one lossy conductor (the earth), and one good conductor (the wire). Beverages have excellent directivity if erected properly, but they are quite inefficient because they are mounted close to the ground. This is in contrast with the terminated long-wire antennas described earlier, which are typically mounted high off the ground. Beverage antennas are not suitable for use as transmitting antennas.

Because the Beverage is a traveling wave, terminated antenna, it has no standing waves resulting from radio signals. As a wave strikes the end of the Beverage from the desired direction, the wave induces voltages along the antenna and continues traveling in space as well. Fig 31B shows part of a wave on the antenna resulting from a desired signal. This diagram also shows the tilt of the wave. The signal induces equal voltages in both directions. The resulting currents are equal and travel in both directions; the component traveling toward the termination end moves *against* the wave and thus builds down to a very low level at

the termination end. Any residual signal resulting from this direction of current flow will be absorbed in the termination (if the termination is equal to the antenna impedance). The component of the signal flowing in the other direction, as we will see, becomes a key part of the received signal.

As the wave travels along the wire, the wave in space travels at approximately the same velocity. (There is some phase delay in the wire, as we shall see.) At any given point in time, the wave traveling along in space induces a voltage in the wire in addition to the wave already traveling on the wire (voltages already induced by the wave). Because these two waves are nearly in phase, the voltages add and build toward a maximum at the receiver end of the antenna.

This process can be likened to a series of signal generators lined up on the wire, with phase differences corresponding to their respective spacings on the wire (Fig 31C). At the receiver end, a maximum voltage is produced by these voltages adding in phase. For example, the wave component induced at the receiver end of the antenna will be in phase (at the receiver end) with a component of the same wave induced, say, 270° (or any other distance) down the antenna, after it travels to the receiver end.

In practice, there is some phase shift of the wave on the wire with respect to the wave in space. This phase shift results from the velocity factor of the antenna. (As with any transmission line, the signal velocity on the Beverage is somewhat less than in free space.) Velocity of propagation on a Beverage is typically between 85 and 98% of that in free space. As antenna height is increased to a certain optimum height (which is about 10 feet for 160 meters), the velocity factor increases. Beyond this height, only minimal improvement is afforded, as shown in Fig 32. These curves are the result of experimental work done in 1922 by RCA, and reported in a *QST* article (November 1922) entitled “The Wave Antenna for 200-Meter Reception,” by H. H. Beverage. The curve for 160 meters was extrapolated from the other curves.

Phase shift (per wavelength) is shown as a function of velocity factor in Fig 33, and is given by:

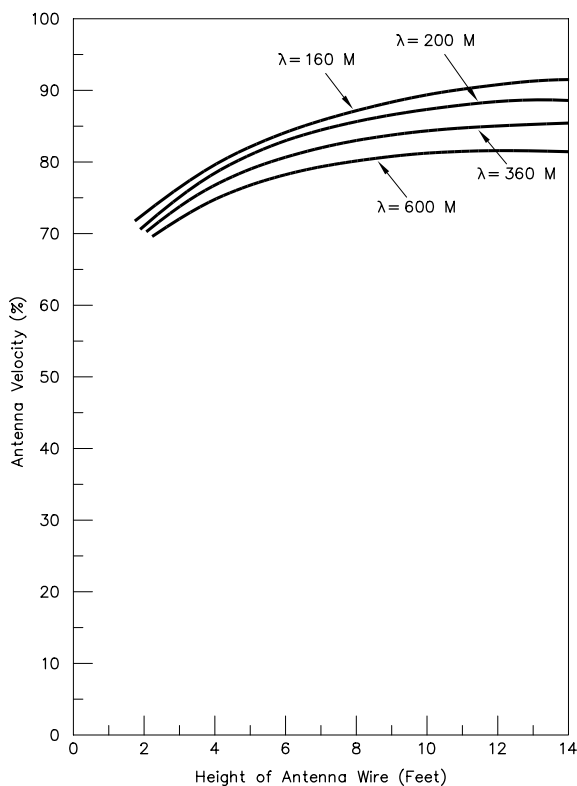
$$\theta = 360 \left( \frac{100}{k} - 1 \right) \quad (\text{Eq 2})$$

where  $k$  = velocity factor of the antenna in percent.

The signals present on and around a Beverage antenna are shown graphically in A through D of Fig 34. These curves show relative voltage levels over a number of periods of the wave in space and their relative effects in terms of the total signal at the receiver end of the antenna.

### Performance in Other Directions

The performance of a Beverage antenna in directions other than the favored one is quite different than previously discussed. Take, for instance, the case of a signal arriving perpendicular to the wire (90° either side of the favored direction). In this case, the wave induces voltages along the wire that are essentially *in phase*, so that they arrive at the

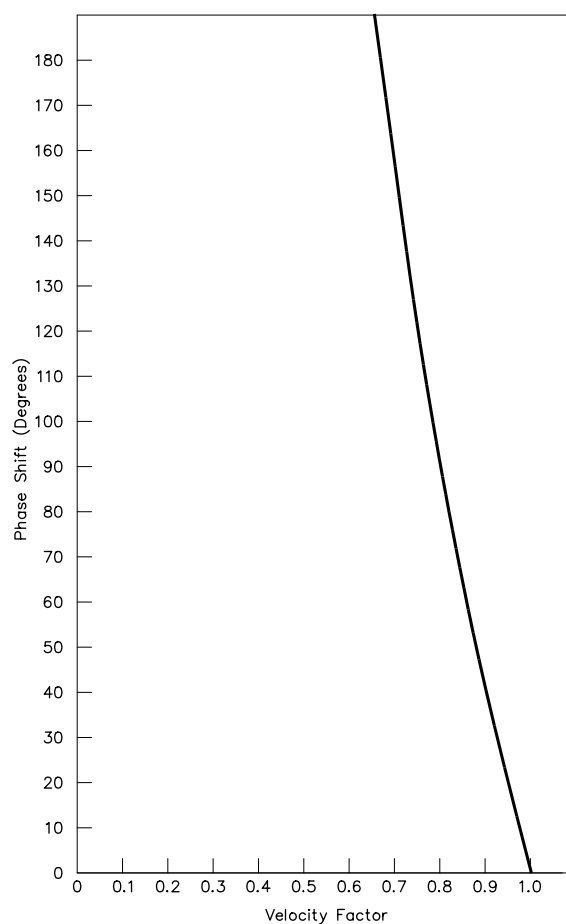


**Fig 32—Signal velocity on a Beverage increases with height above ground, and reaches a practical maximum at about 10 feet. Improvement is minimal above this height. (The velocity of light is 100%.)**

receiver end more or less out of phase, and thus cancel. (This can be likened to a series of signal generators lined up along the antenna as before, but having no progressive phase differences.)

As a result of this cancellation, Beverages exhibit deep nulls off the sides. Some minor sidelobes will exist, as with other long-wire antennas, and will increase in number with the length of the antenna.

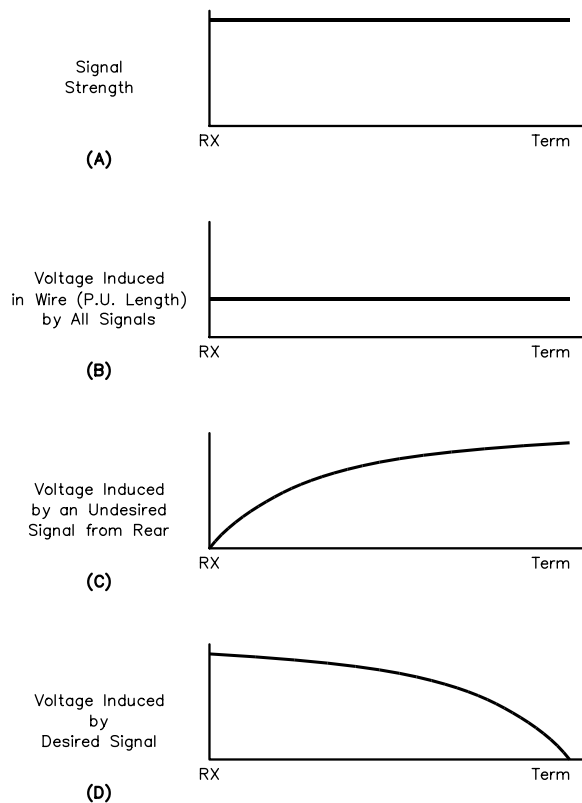
In the case of a signal arriving from the rear of the antenna, the behavior of the antenna is very similar to its performance in the favored direction. The major difference is that the signal from the rear adds in phase at the termination end and is absorbed by the termination impedance. **Fig 35** compares the azimuth and elevation patterns for a  $2\text{-}\lambda$  (1062 foot) and a  $1\text{-}\lambda$  (531 foot) Beverage at 1.83 MHz. The wire is mounted 8 feet above flat ground (to keep it above deer antlers and away from humans too) and is terminated with a  $500\text{-}\Omega$  resistor in each case, although the exact value of the terminating resistance is not very critical. The ground constants assumed in this computer model are conductivity of 5 mS/m and a dielectric constant of 13. Beverage dielectric performance tends to decrease as the ground becomes better. Beverages operated over saltwater do not work as well as they do over poor ground.



**Fig 33—This curve shows phase shift (per wavelength) as a function of velocity factor on a Beverage antenna. Once the phase shift for the antenna goes beyond  $90^\circ$ , the gain drops off from its peak value, and any increase in antenna length will decrease gain.**

For most effective operation, the Beverage should be terminated in an impedance equal to the characteristic impedance  $Z_{ANT}$  of the antenna. For maximum signal transfer to the receiver you should also match the receiver's input impedance to the antenna. If the termination impedance is not equal to the characteristic impedance of the antenna, some part of the signal from the rear will be reflected back toward the receiver end of the antenna.

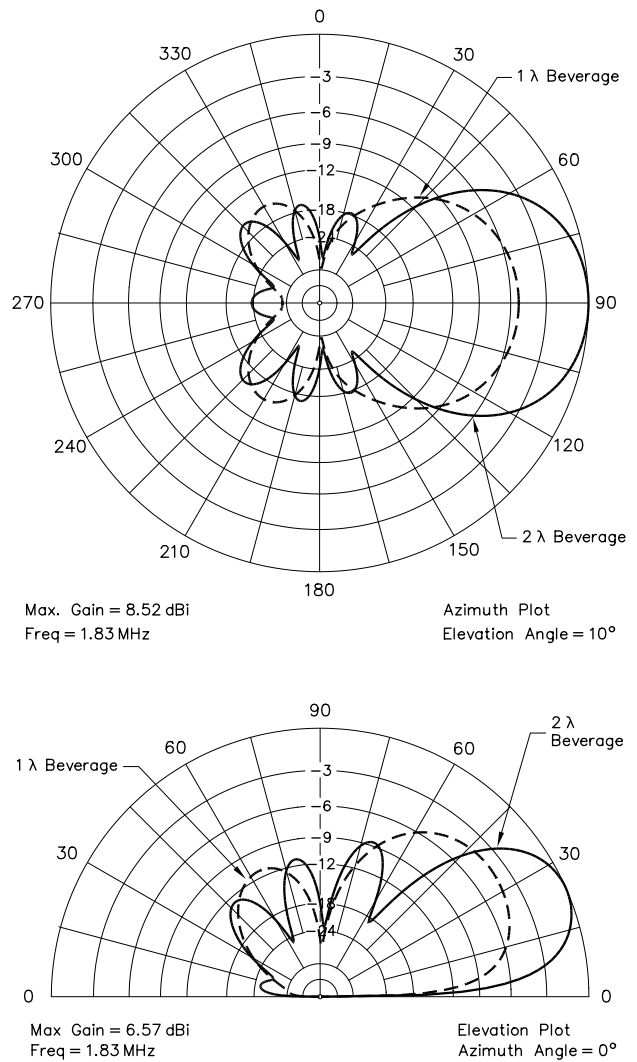
If the termination impedance is merely an open circuit (no terminating resistor), total reflection will result and the antenna will exhibit a bidirectional pattern (still with very deep nulls off the sides). An unterminated Beverage will not have the same response to signals in the rearward direction as it exhibits to signals in the forward direction because of attenuation and reradiation of part of the reflected wave as it travels back toward the receiver end. **Fig 36** compares the response from two  $2\text{-}\lambda$  Beverages, one terminated and the other unterminated. Just like a terminated long-wire transmitting antenna (which is mounted higher off the ground



**Fig 34**—These curves show the voltages that appear in a Beverage antenna over a period of several cycles of the wave. Signal strength (at A) is constant over the length of the antenna during this period, as is voltage induced per unit length in the wire (at B). (The voltage induced in any section of the antenna is the same as the voltage induced in any other section of the same size, over the same period of time.) At C, the voltages induced by an undesired signal from the rearward direction add in phase and build to a maximum at the termination end, where they are dissipated in the termination (if  $Z_{\text{term}} = Z_0$ ). The voltages resulting from a desired signal are shown at D. The wave on the wire travels closely with the wave in space, and the voltages resulting add in phase to a maximum at the receiver end of the antenna.

than a Beverage, which is meant only for receiving), the terminated Beverage has a reduced forward lobe compared to its unterminated sibling. The unterminated Beverage exhibits about a 5 dB front-to-back ratio for this length because of the radiation and wire and ground losses that occur before the forward wave gets to the end of the wire.

If the termination is between the extremes (open circuit and perfect termination in  $Z_{\text{ANT}}$ ), the peak direction and intensity of signals off the rear of the Beverage will change. As a result, an adjustable reactive termination can be employed to *steer* the nulls to the rear of the antenna (see Fig 37). This can be of great help in eliminating a local interfering signal from a rearward direction (typically 30° to 40° either side of the back direction). Such a scheme doesn't help much for interfering skywave signals because of



**Fig 35**—At top, azimuthal patterns of a 2- $\lambda$  (solid line) and a 1- $\lambda$  (dashed line) Beverage antenna, terminated with 550- $\Omega$  resistor at 1.83 MHz, at an elevation angle of 10°. The rearward pattern around 180° is more than 20 dB down from the front lobe for each antenna. Above, the elevation-plane patterns. Note the rejection of very high-angle signals near 90°.

variations encountered in the ionosphere that constantly shift polarity, amplitude, phase and incoming elevation angles.

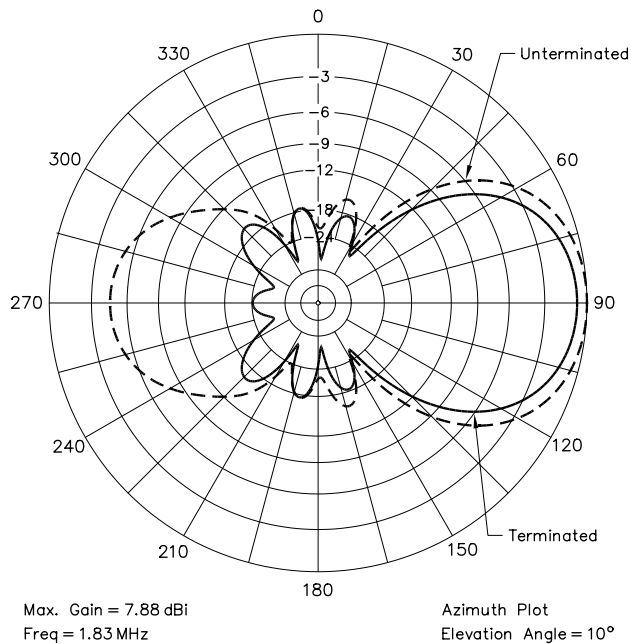
To determine the appropriate value for a terminating resistor, you need to know the characteristic impedance (surge impedance),  $Z_{\text{ANT}}$ , of the Beverage. It is interesting to note that  $Z_{\text{ANT}}$  is not a function of the length, just like a transmission line.

$$Z_{\text{ANT}} = 138 \times \log\left(\frac{4h}{d}\right) \quad (\text{Eq 3})$$

where

$Z_{\text{ANT}}$  = characteristic impedance of the Beverage = terminating resistance needed





**Fig 36—Comparing the azimuthal patterns for a 2-λ Beverage, terminated (solid line) and unterminated (dashed line).**

h = wire height above ground  
d = wire diameter (in the same units as h)

Another aspect of terminating the Beverage is the quality of the RF ground used for the termination. For most types of soil a ground rod is sufficient, since the optimum value for the termination resistance is in the range of 400 to 600 Ω for typical Beverages and the ground-loss resistance is in series with this. Even if the ground-loss resistance at the termination point is as high as 40 or 50 Ω, it still is not an appreciable fraction of the overall terminating resistance. For soil with very poor conductivity, however (such as sand or

rock), you can achieve a better ground termination by laying radial wires on the ground at the both the receiver and termination ends. These wires need not be resonant quarter-wave in length, since the ground detunes them anyway. Like the ground counterpoise for a vertical antenna, a number of short radials is better than a few long ones. Some amateurs use chicken-wire ground screens for their ground terminations.

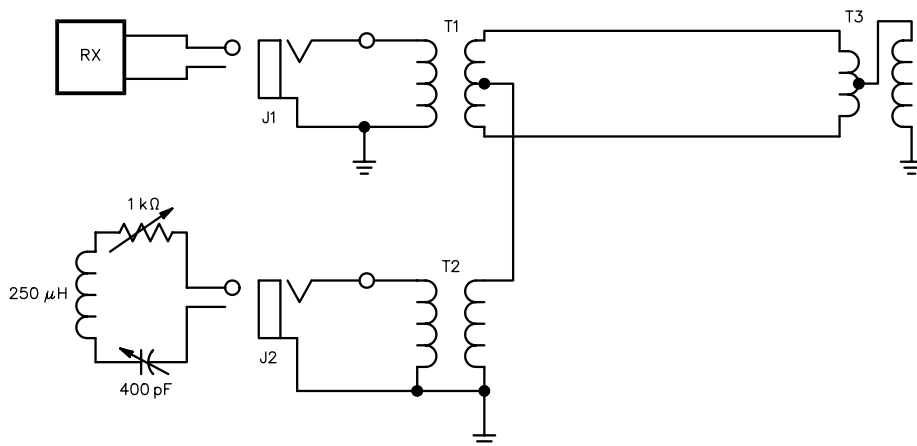
As with many other antennas, improved directivity and gain can be achieved by lengthening the antenna and by arranging several antennas into an array. One item that must be kept in mind is that by virtue of the velocity factor of the antenna, there is some phase shift of the wave on the antenna with respect to the wave in space. Because of this phase shift, although the directivity will continue to sharpen with increased length, there will be some optimum length at which the gain of the antenna will peak. Beyond this length, the current increments arriving at the receiver end of the antenna will no longer be in phase, and will not add to produce a maximum signal at the receiver end. This optimum length is a function of velocity factor and frequency, and is given by:

$$L = \frac{\lambda}{4 \left( \frac{100}{k} - 1 \right)} \quad (\text{Eq 4})$$

where

- L = maximum effective length
- λ = signal wavelength in free space (same units as L)
- k = velocity factor of the antenna in percent

Because velocity factor increases with height (to a point, as mentioned earlier), optimum length is somewhat longer if the antenna height is increased. The maximum effective length also increases with the number of wires in the antenna system. For example, for a two-wire Beverage like the bidirectional version shown in Fig 37, the maximum effective length is about 20% longer than the single-wire version. A typical



**Fig 37—A two-wire Beverage antenna that has provisions for direction switching and null steering in the rear quadrant. Performance improves with height to a point, and is optimum for 1.8-MHz operation at about 10 to 12 feet. Parts identifications are for text reference.**

length for a single-wire 1.8-MHz Beverage (made of #16 wire and erected 10 feet above ground) is about 1200 feet.

### Feed-Point Transformers for Single-Wire Beverages

Matching transformer T1 in Fig 31 is easily constructed. Small toroidal ferrite cores are best for this application, with those of high permeability ( $\mu_i = 125$  to 5000) being the easiest to wind (requiring fewest turns) and having the best high-frequency response (because few turns are used). Trifilar-wound autotransformers are most convenient.

Most users are not concerned with a small amount of SWR on the transmission line feeding their Beverages. For example, let us assume that the  $Z_{ANT}$  of a particular Beverage is 525  $\Omega$  and the terminating resistance is made equal to that value. If a standard 3:1 turns-ratio autotransformer is used at the input end of the antenna, the nominal impedance transformation  $50 \Omega \times 3^2 = 450 \Omega$ . This leads to the terminology often used for this transformer as a 9:1 transformer, referring to its impedance transformation. The resulting SWR on the feed line going back to the receiver would be  $525/450 = 1.27:1$ , not enough to be concerned about. For a  $Z_{ANT}$  of 600  $\Omega$ , the SWR is  $600/450 = 1.33:1$ , again not a matter of concern.

Hence, most Beverage users use standard 9:1 (450:50  $\Omega$ ) autotransformers. You can make a matching transformer suitable for use from 160 to 40 meters using eight trifilar turns of #24 enameled wire wound over a stack of two Amidon FT-50-75 or two MN8-CX cores. See Fig 38.

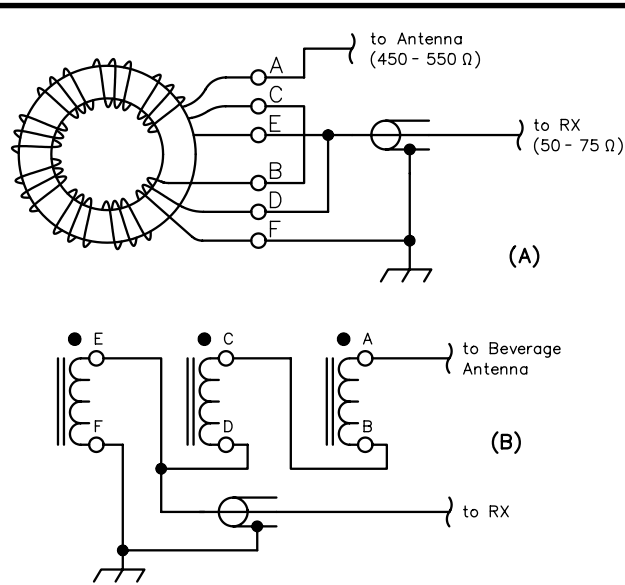
Make your own trifilar cable bundle by placing three 3-foot lengths of the #24 wire side-by-side and twisting them in a hand drill so that there is a uniform twist about one twist-per-inch. This holds the three wires together in a bundle that can be passed through the two stacked cores, rather like threading a needle. Remember that each time you put the bundle through the center of the cores counts as one turn.

After you finish winding, cut the individual wires to leave about  $3/4$ -inch leads, sand off the enamel insulation and tin the wires with a soldering iron. Identify the individual wires with an ohmmeter and then connect them together following Fig 38. Coat the transformer with Q-dope (liquid polystyrene) to finalize the transformer. White glue will work also. See Chapters 25 and 26 and *The ARRL Handbook* for more information on winding toroidal transformers or see Chapter 7 (Special Receiving Antennas) of *ON4UN's Low-Band DXing*, published by ARRL.

### The Two-Wire Beverage

The two-wire antenna shown in Fig 37 has the major advantage of having signals from both directions available at the receiver at the flip of a switch between J1 and J2. Also, because there are two wires in the system (equal amounts of signal voltage are induced in both wires), greater signal voltages will be produced.

A signal from the left direction in Fig 37 induces equal voltages in both wires, and equal in-phase currents flow as a result. The reflection transformer (T3 at the right-hand



**Fig 38—Constructing the feed-point transformer for a single-wire Beverage. See text for details.**

end of the antenna) then inverts the phase of these signals and reflects them back down the antenna toward the receiver, using the antenna wires as a balanced open-wire transmission line. This signal is then transformed by T1 down to the input impedance of the receiver (50  $\Omega$ ) at J1.

Signals traveling from right to left also induce equal voltages in each wire, and they travel in phase toward the receiver end, through T1, and into T2. Signals from this direction are available at J2.

T1 and T2 are standard 9:1 wideband transformers capable of operating from 1.8 to at least 10 MHz. Like any two parallel wires making up a transmission line, the two-wire Beverage has a certain characteristic impedance—we'll call it  $Z_1$  here—depending on the spacing between the two wires and the insulation between them. T3 transforms the terminating resistance needed at the end of the line to  $Z_1$ . Keep in mind that this terminating resistance is equal to the characteristic impedance  $Z_{ANT}$  of the Beverage—that is, the impedance of the parallel wires over their images in the ground below. For example, if  $Z_1$  of the Beverage wire is 300  $\Omega$  (that is, you used TV twin-lead for the two Beverage wires), T3 must transform the balanced 300  $\Omega$  to the unbalanced 500  $\Omega$   $Z_{ANT}$  impedance used to terminate the Beverage.

The design and construction of the reflection transformer used in a two-wire Beverage is more demanding than that for the straightforward matching transformer T1 because the exact value of terminating impedance is more critical for good F/B. See Chapter 7 (Special Receiving Antennas) in *ON4UN's Low-Band DXing* for details on winding the reflection transformers for a two-wire Beverage.

Another convenient feature of the two-wire Beverage is the ability to steer the nulls off either end of the antenna while receiving in the opposite direction. For instance, if the series RLC network shown at J2 is adjusted while the

receiver is connected to J1, signals can be received from the left direction while interference coming from the right can be partially or completely nulled. The nulls can be steered over a 60° (or more) area off the right-hand end of the antenna. The same null-steering capability exists in the opposite direction with the receiver connected at J2 and the termination connected at J1.

The two-wire Beverage is typically erected at the same height as a single-wire version. The two wires are at the same height and are spaced uniformly—typically 12 to 18 inches apart for discrete wires. Some amateurs construct two-wire Beverages using “window” ladder-line, twisting the line about three twists per foot for mechanical and electrical stability in the wind.

The characteristic impedance  $Z_{ANT}$  of a Beverage made using two discrete wires with air insulation between them depends on the wire size, spacing and height and is given by:

$$Z_{ANT} = 69 \times \log \left[ \frac{4h}{d} \sqrt{1 + \frac{(2h)^2}{S}} \right] \quad (\text{Eq 5})$$

where

$Z_{ANT}$  = Beverage impedance = desired terminating resistance

S = wire spacing

h = height above ground

d = wire diameter (in same units as S and h)

### Practical Considerations

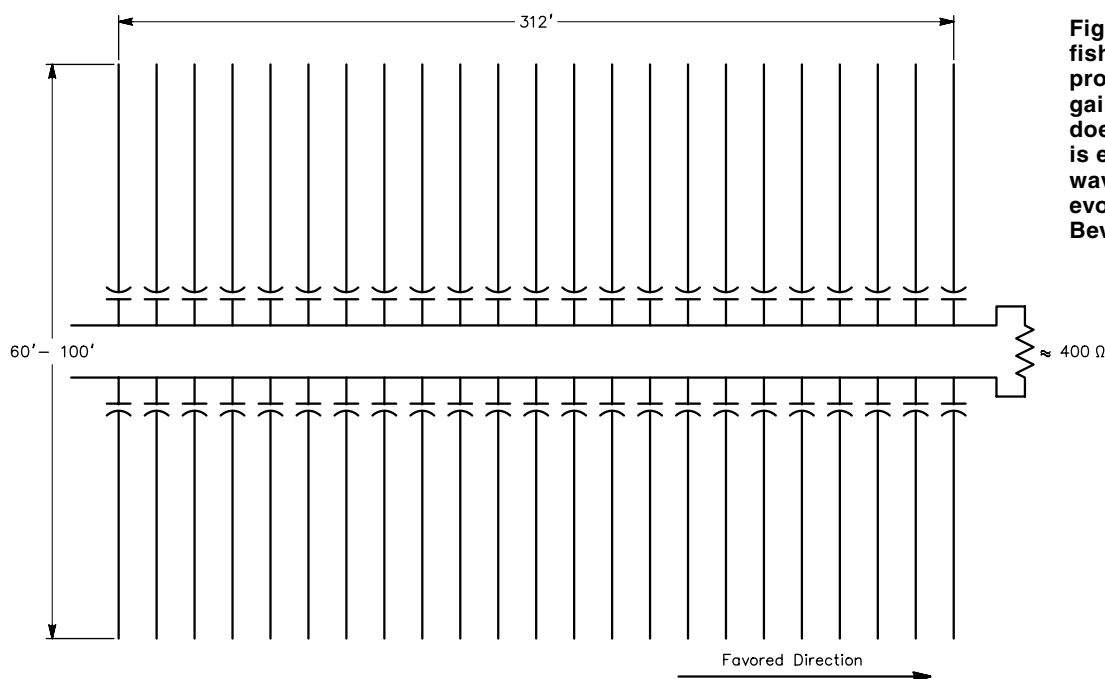
Even though Beverage antennas have excellent directive

patterns if terminated properly, gain never exceeds about -3 dBi in most practical installations. However, the directivity that the Beverage provides results in a much higher signal-to-noise ratio for signals in the desired direction than almost any other real-world antenna used at low frequencies.

A typical situation might be a station located in the US Northeast (W1), trying to receive Topband signals from Europe to the northeast, while thunderstorms behind him in the US Southeast (W4) are creating huge static crashes. Instead of listening to an S7 signal with 10-dB over S9 noise and interference on a vertical, the directivity of a Beverage will typically allow you to copy the same signal at perhaps S5 with only S3 (or lower) noise and interference. This is certainly a worthwhile improvement. However, if you are in the middle of a thunderstorm, or if there is a thunderstorm in the direction from which you are trying to receive a signal, no Beverage is going to help you!

There are a few basic principles that must be kept in mind when erecting Beverage antennas if optimum performance is to be realized.

- 1) Plan the installation thoroughly, including choosing an antenna length consistent with the optimum length values discussed earlier.
- 2) Keep the antenna as straight and as nearly level as possible over its entire run. Avoid following the terrain under the antenna too closely—keep the antenna level with the average terrain.
- 3) Minimize the lengths of vertical downleads at the ends of the antenna. Their effect is detrimental to the directive pattern of the antenna. It is best to slope the antenna wire from ground level to its final height (over a distance of 50 feet or so) at the feed-point end. Similar action should



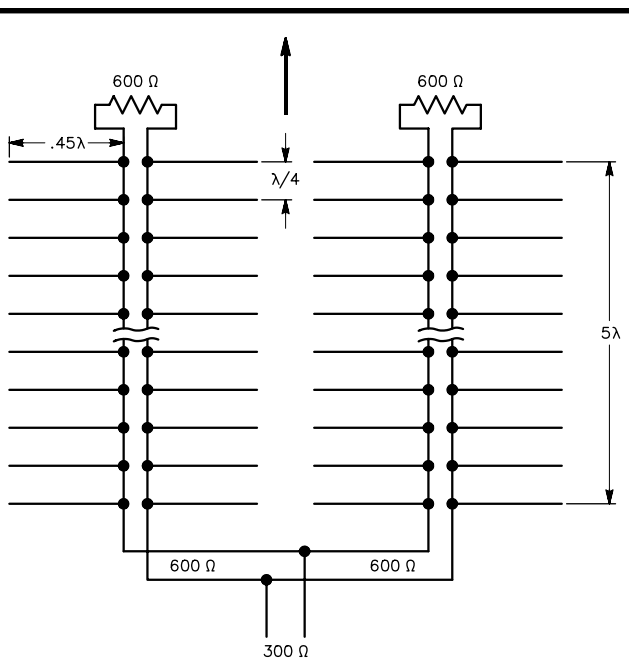
**Fig 39—The fishbone antenna provides higher gain per acre than does a rhombic. It is essentially a wave antenna that evolved from the Beverage.**

be taken at the termination end. Be sure to seal the transformers against weather.

- 4) Use a noninductive resistor for terminating a single-wire Beverage. If you live in an area where lightning storms are common, use 2-W terminating resistors, which can survive surges due to nearby lightning strikes.
- 5) Use high-quality insulators for the Beverage wire where it comes into contact with the supports. Plastic insulators designed for electric fences are inexpensive and effective.
- 6) Keep the Beverage away from parallel conductors such as electric power and telephone lines for a distance of at least 200 feet. Perpendicular conductors, even other Beverages, may be crossed with relatively little interaction, but do not cross any conductors that may pose a safety hazard.
- 7) Run the coaxial feed line to the Beverage so that it is not directly under the span of the wire. This prevents common-mode currents from appearing on the shield of the coax. It may be necessary to use a ferrite-bead choke on the feed line if you find that the feed line itself picks up signals when it is temporarily disconnected from the Beverage. See Chapter 26 for details on common-mode chokes.
- 8) If you use elevated radials in your transmitting antenna system, keep your Beverage feed lines well away from them to avoid stray pickup that will ruin the Beverage's directivity.

### FISHBONE ANTENNAS

Another type of wave antenna is the *fishbone*, which, unlike the Beverage, is well suited to use at HF. A simple fishbone antenna is illustrated in Fig 39. Its impedance is



**Fig 40—The English HAD fishbone antenna is a simplified version of the standard fishbone. It may be used as a single-bay antenna fed with 600-Ω open-wire line.**

approximately 400 Ω. The antenna is formed of closely spaced elements that are lightly coupled (capacitively) to a long, terminated transmission line. The capacitors are chosen to have a value that will keep the velocity of propagation of RF on the line more than 90% of that in air. The elements are usually spaced approximately  $0.1 \lambda$  (or slightly more) so that an average of seven or more elements are used for each full wavelength of transmission-line length. This antenna obtains low-angle response primarily as a function of its height, and therefore, is generally installed 60 to 120 feet above ground. If the antenna is to be used for transmission (for which it is well suited because of its excellent gain and broadband nature), transmitting-type capacitors must be used, since they must handle substantial current.

The English HAD fishbone antenna, shown in its two-bay form in Fig 40, is less complicated than the one of Fig 39. It may be used singly, of course, and may be fed with 600-Ω open-wire line. Installation and operational characteristics are similar to the standard fishbone antenna.

### BIBLIOGRAPHY

Source material and more extended discussion of topics covered in this chapter can be found in the references given below.

- A. Bailey, S. W. Dean and W. T. Wintringham, "The Receiving System for Long-Wave Transatlantic Radio Telephony," *The Bell System Technical Journal*, Apr 1929.
- J. S. Belrose, "Beverage Antennas for Amateur Communications," Technical Correspondence, *QST*, Sep 1981.
- H. H. Beverage, "Antennas," *RCA Review*, Jul 1939.
- H. H. Beverage and D. DeMaw, "The Classic Beverage Antenna Revisited," *QST*, Jan 1982.
- B. Boothe, "Weak-Signal Reception on 160—Some Antenna Notes," *QST*, Jun 1977.
- E. Bruce, "Developments in Short-Wave Directive Antennas," *Proc IRE*, Aug 1931.
- E. Bruce, A. C. Beck and L. R. Lowry, "Horizontal Rhombic Antennas," *Proc IRE*, Jan 1935.
- P. S. Carter, C. W. Hansel and N. E. Lindenblad, "Development of Directive Transmitting Antennas by R.C.A. Communications," *Proc IRE*, Oct 1931.
- J. Devoldere, *ON4UN's Low-Band DXing* (Newington: ARRL, 1999). See in particular Chapter 7, "Special Receiving Antennas," for many practical details on Beverage antennas.
- A. E. Harper, *Rhombic Antenna Design* (New York: D. Van Nostrand Co, Inc).
- E. A. Laport, "Design Data for Horizontal Rhombic Antennas," *RCA Review*, Mar 1952.
- G. M. Miller, *Modern Electronic Communication* (Englewood Cliffs, NJ: Prentice Hall, 1983).
- V. A. Misek, *The Beverage Antenna Handbook* (Wason Rd., Hudson, NH: W1WCR, 1977).
- F. E. Terman, *Radio Engineering*, Second Edition (New York: McGraw-Hill, 1937).

# Direction Finding Antennas

The use of radio for direction-finding purposes (RDF) is almost as old as its application for communications. Radio amateurs have learned RDF techniques and found much satisfaction by participating in hidden-transmitter hunts. Other hams have discovered RDF through an interest in boating or aviation, where radio direction finding is used for navigation and emergency location systems.

In many countries of the world, the hunting of hidden amateur transmitters takes on the atmosphere of a sport, as participants wearing jogging togs or track suits dash toward the area where they believe the transmitter is located. The sport is variously known as *fox hunting*, *bunny hunting*, ARDF (Amateur Radio direction finding) or simply transmitter hunting. In North America, most hunting of hidden transmitters is conducted from automobiles, although hunts on foot are gaining popularity.

There are less pleasant RDF applications as well, such as tracking down noise sources or illegal operators from unidentified stations. Jammers of repeaters, traffic nets and other amateur operations can be located with RDF equipment. Or sometimes a stolen amateur rig will be operated by a person who is not familiar with Amateur Radio, and by being lured into making repeated transmissions, the operator unsuspectingly permits himself to be located with RDF equipment. The ability of certain RDF antennas to reject signals from selected directions has also been used to advantage in reducing noise and interference. Through APRS, radio navigation is becoming a popular application of RDF. The locating of downed aircraft is another, and one in which amateurs often lend their skills. Indeed, there are many useful applications for RDF.

Although sophisticated and complex equipment pushing the state of the art has been developed for use by governments and commercial enterprises, relatively simple equipment can be built at home to offer the Radio Amateur an opportunity to RDF. This chapter deals with antennas suitable for that purpose.

## RDF by Triangulation

It is impossible, using amateur techniques, to pinpoint the whereabouts of a transmitter from a single receiving location. With a directional antenna you can determine the

direction of a signal source, but not how far away it is. To find the distance, you can then travel in the determined direction until you discover the transmitter location. However, that technique can be time consuming and often does not work very well.

A preferred technique is to take at least one additional direction measurement from a second receiving location. Then use a map of the area and plot the bearing or direction measurements as straight lines from points on the map representing the two locations. The approximate location of the transmitter will be indicated by the point where the two bearing lines cross. Even better results can be obtained by taking direction measurements from three locations and using the mapping technique just described. Because absolutely precise bearing measurements are difficult to obtain in practice, the three lines will almost always cross to form a triangle on the map, rather than at a single point. The transmitter will usually be located inside the area represented by the triangle. Additional information on the technique of triangulation and much more on RDF techniques may be found in recent editions of *The ARRL Handbook*.

## DIRECTION FINDING SYSTEMS

Required for any RDF system are a directive antenna and a device for detecting the radio signal. In amateur applications the signal detector is usually a transceiver and for convenience it will usually have a meter to indicate signal strength. Unmodified, commercially available portable or mobile receivers are generally quite satisfactory for signal detectors. At very close ranges a simple diode detector and dc microammeter may suffice for the detector.

On the other hand, antennas used for RDF techniques are not generally the types used for normal two-way communications. Directivity is a prime requirement, and here the word *directivity* takes on a somewhat different meaning than is commonly applied to other amateur antennas. Normally we associate directivity with gain, and we think of the ideal antenna pattern as one having a long, thin main lobe. Such a pattern may be of value for coarse measurements in RDF work, but precise bearing measurements are not possible. There is always a spread of

a few (or perhaps many) degrees on the *nose* of the lobe, where a shift of antenna bearing produces no detectable change in signal strength. In RDF measurements, it is desirable to correlate an exact bearing or compass direction with the position of the antenna. In order to do this as accurately as possible, an antenna exhibiting a *null* in its pattern is used. A null can be very sharp in directivity, to within a half degree or less.

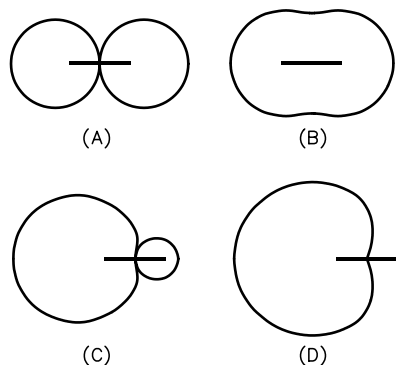
### Loop Antennas

A simple antenna for HF RDF work is a small loop tuned to resonance with a capacitor. Several factors must be considered in the design of an RDF loop. The loop must be small in circumference compared with the wavelength. In a single-turn loop, the conductor should be less than  $0.08 \lambda$  long. For 28 MHz, this represents a length of less than 34 inches (a diameter of approximately 10 inches). Maximum response from the loop antenna is in the plane of the loop, with nulls exhibited at right angles to that plane.

To obtain the most accurate bearings, the loop must be balanced electrostatically with respect to ground. Otherwise, the loop will exhibit two modes of operation. One is the mode of a true loop, while the other is that of an essentially nondirectional vertical antenna of small dimensions. This second mode is called the *antenna effect*. The voltages introduced by the two modes are seldom in phase and may add or subtract, depending upon the direction from which the wave is coming.

The theoretical true loop pattern is illustrated in **Fig 1A**. When properly balanced, the loop exhibits two nulls that are  $180^\circ$  apart. Thus, a single null reading with a small loop antenna will not indicate the exact direction toward the transmitter—only the line along which the transmitter lies. Ways to overcome this ambiguity are discussed later.

When the antenna effect is appreciable and the loop is tuned to resonance, the loop may exhibit little directivity, as



**Fig 1**—Small-loop field patterns with varying amounts of antenna effect—the undesired response of the loop acting merely as a mass of metal connected to the receiver antenna terminals. The straight lines show the plane of the loop.

shown in **Fig 1B**. However, by detuning the loop to shift the phasing, a pattern similar to **1C** may be obtained. Although this pattern is not symmetrical, it does exhibit a null. Even so, the null may not be as sharp as that obtained with a loop that is well balanced, and it may not be at exact right angles to the plane of the loop.

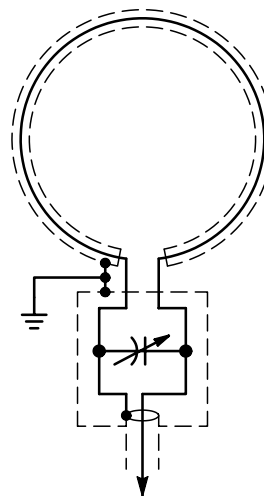
By suitable detuning, the unidirectional cardioid pattern of **Fig 1D** may be approached. This adjustment is sometimes used in RDF work to obtain a unidirectional bearing, although there is no complete null in the pattern. A cardioid pattern can also be obtained with a small loop antenna by adding a *sensing element*. Sensing elements are discussed in a later section of this chapter.

An electrostatic balance can be obtained by shielding the loop, as **Fig 2** shows. The shield is represented by the broken lines in the drawing, and eliminates the antenna effect. The response of a well-constructed shielded loop is quite close to the ideal pattern of **Fig 1A**.

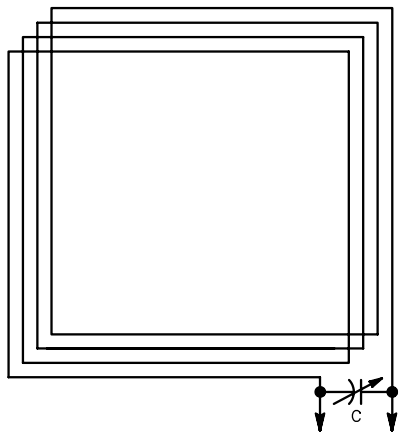
For the low-frequency amateur bands, single-turn loops of convenient physical size for portability are generally found to be unsatisfactory for RDF work. Therefore, multiturn loops are generally used instead. Such a loop is shown in **Fig 3**. This loop may also be shielded, and if the total conductor length remains below  $0.08 \lambda$ , the directional pattern is that of **Fig 1A**. A sensing element may also be used with a multiturn loop.

### Loop Circuits and Criteria

No single word describes a direction-finding loop of high performance better than *symmetry*. To obtain an undistorted response pattern from this type of antenna, you must build it in the most symmetrical manner possible. The next key word is *balance*. The better the electrical balance, the deeper the loop null and the sharper the maxima.



**Fig 2**—Shielded loop for direction finding. The ends of the shielding turn are not connected, to prevent shielding the loop from magnetic fields. The shield is effective against electric fields.



**Fig 3—Small loop consisting of several turns of wire. The total conductor length is very much less than a wavelength. Maximum response is in the plane of the loop.**

The physical size of the loop for 7 MHz and below is not of major consequence. A 4-foot diameter loop will exhibit the same electrical characteristics as one which is only an inch or two in diameter. The smaller the loop, however, the lower its efficiency. This is because its aperture samples a smaller section of the wave front. Thus, if you use loops that are very small in terms of a wavelength, you will need preamplifiers to compensate for the reduced efficiency.

An important point to keep in mind about a small loop antenna oriented in a vertical plane is that it is vertically polarized. It should be fed at the bottom for the best null response. Feeding it at one side, rather than at the bottom, will not alter the polarization and will only degrade performance. To obtain horizontal polarization from a small loop, it must be oriented in a horizontal plane, parallel to the earth. In this position the loop response is essentially omnidirectional.

The earliest loop antennas were of the *frame antenna* variety. These were unshielded antennas built on a wooden frame in a rectangular format. The loop conductor could be a single turn of wire (on the larger units) or several turns if the frame was small. Later, shielded versions of the frame antenna became popular, providing electrostatic shielding—an aid to noise reduction from such sources as precipitation static.

### Ferrite Rod Antennas

With advances in technology, magnetic-core loop antennas came into use. Their advantage was reduced size, and this appealed especially to the designers of aircraft and portable radios. Most of these antennas contain ferrite bars or cylinders, which provide high inductance and Q with a relatively small number of coil turns.

Magnetic-core antennas consist essentially of turns of wire around a ferrite rod. They are also known as *loopstick*

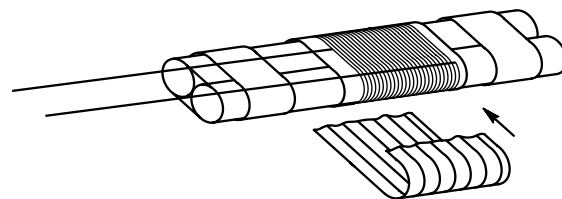
antennas. Probably the best-known example of this type of antenna is that used in small portable AM broadcast receivers. Because of their reduced-size advantage, ferrite-rod antennas are used almost exclusively for portable work at frequencies below 150 MHz.

As implied in the earlier discussion of shielded loops in this chapter, the true loop antenna responds to the magnetic field of the radio wave, and not to the electrical field. The voltage delivered by the loop is proportional to the amount of magnetic flux passing through the coil, and to the number of turns in the coil. The action is much the same as in the secondary winding of a transformer. For a given size of loop, the output voltage can be increased by increasing the flux density, and this is done with a ferrite core of high permeability. A 1/2-inch diameter, 7-inch rod of Q2 ferrite ( $\mu_i = 125$ ) is suitable for a loop core from the broadcast band through 10 MHz. For increased output, the turns may be wound on two rods that are taped together, as shown in **Fig 4**. Loopstick antennas for construction are described later in this chapter.

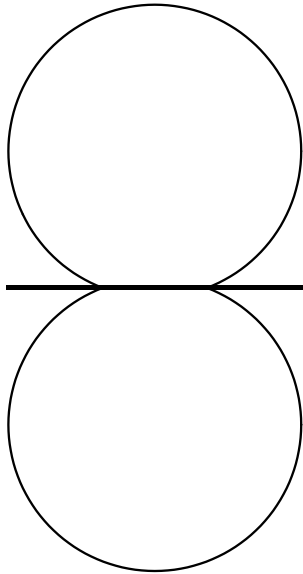
Maximum response of the loopstick antenna is broadside to the axis of the rod as shown in **Fig 5**, whereas maximum response of the ordinary loop is in a direction at right angles to the plane of the loop. Otherwise, the performances of the ferrite-rod antenna and of the ordinary loop are similar. The loopstick may also be shielded to eliminate the antenna effect, such as with a U-shaped or C-shaped channel of aluminum or other form of *trough*. The length of the shield should equal or slightly exceed the length of the rod.

### Sensing Antennas

Because there are two nulls that are 180° apart in the directional pattern of a loop or a loopstick, an ambiguity exists as to which one indicates the true direction of the station being tracked. For example, assume you take a bearing measurement and the result indicates the transmitter is somewhere on a line running approximately east and west



**Fig 4—A ferrite-rod or loopstick antenna. Turns of wire may be wound on a single rod, or to increase the output from the loop, the core may be two rods taped together, as shown here. The type of core material must be selected for the intended frequency range of the loop. To avoid bulky windings, fine wire such as #28 or #30 is often used, with larger wire for the leads.**



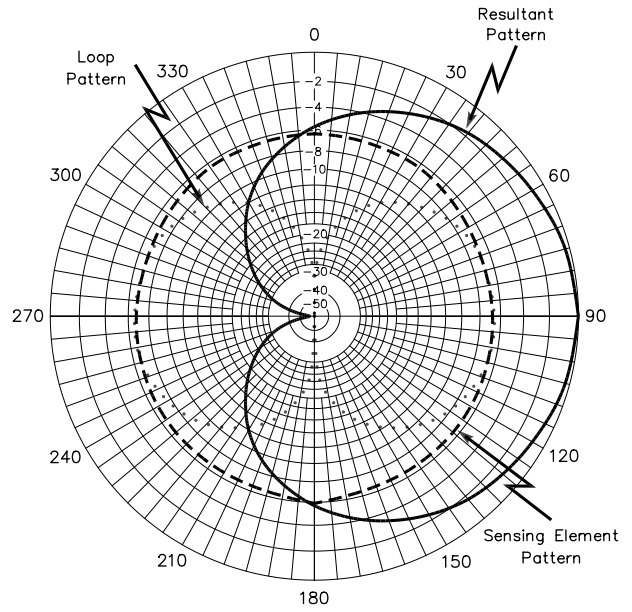
**Fig 5—Field pattern for a ferrite rod antenna. The dark bar represents the rod on which the loop turns are wound.**

from your position. With this single reading, you have no way of knowing for sure if the transmitter is east of you or west of you.

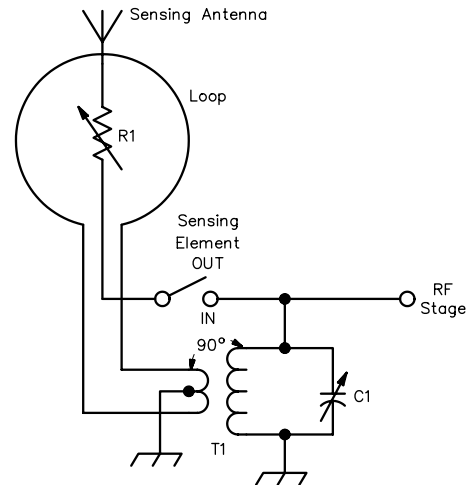
If more than one receiving station takes bearings on a single transmitter, or if a single receiving station takes bearings from more than one position on the transmitter, the ambiguity may be worked out by triangulation, as described earlier. However, it is sometimes desirable to have a pattern with only one null, so there is no question about whether the transmitter in the above example would be east or west from your position.

A loop or loopstick antenna may be made to have a single null if a second antenna element is added. The element is called a *sensing antenna*, because it gives an added sense of direction to the loop pattern. The second element must be omnidirectional, such as a short vertical. When the signals from the loop and the vertical element are combined with a 90° phase shift between the two, a cardioid pattern results. The development of the pattern is shown in **Fig 6A**.

Fig 6B shows a circuit for adding a sensing antenna to a loop or loopstick. R1 is an internal adjustment and is used to set the level of the signal from the sensing antenna. For the best null in the composite pattern, the signals from the loop and the sensing antenna must be of equal amplitude, so R1 is adjusted experimentally during setup. In practice, the null of the cardioid is not as sharp as that of the loop, so the usual measurement procedure is to first use the loop alone to obtain a precise bearing reading, and then to add the sensing antenna and take another reading to resolve the ambiguity. (The null of the cardioid is 90° away from the nulls of the loop.) For this reason, provisions are usually



(A)



(B)

**Fig 6—At A, the directivity pattern of a loop antenna with sensing element. At B is a circuit for combining the signals from the two elements. C1 is adjusted for resonance with T1 at the operating frequency.**

made for switching the sensing element in an out of operation.

### PHASED ARRAYS

Phased arrays are also used in amateur RDF work. Two general classifications of phased arrays are end-fire and broadside configurations. Depending on the spacing and phasing of the elements, end-fire patterns may exhibit a null in one direction along the axis of the elements. At the same time, the response is maximum off the other end of the axis, in the opposite direction from the null. A familiar



arrangement is two elements spaced  $\frac{1}{4} \lambda$  apart and fed  $90^\circ$  out of phase. The resultant pattern is a *cardioid*, with the null in the direction of the leading element. Other arrangements of spacing and phasing for an end-fire array are also suitable for RDF work. One of the best known is the *Adcock array*, discussed in the next section.

Broadside arrays are inherently bidirectional, which means there are always at least two nulls in the pattern. Ambiguity therefore exists in the true direction of the transmitter, but depending on the application, this may be no handicap. Broadside arrays are seldom used for amateur RDF applications however.

### The Adcock Antenna

Loops are adequate in RDF applications where only the ground wave is present. The performance of an RDF system for sky-wave reception can be improved by the use of an Adcock antenna, one of the most popular types of end-fire phased arrays. A basic version is shown in Fig 7.

This system was invented by F. Adcock and patented in 1919. The array consists of two vertical elements fed  $180^\circ$  apart, and mounted so the system may be rotated. Element spacing is not critical, and may be in the range from  $0.1$  to  $0.75 \lambda$ . The two elements must be of identical lengths, but need not be self-resonant. Elements that are shorter than resonant are commonly used. Because neither the element spacing nor the length is critical in terms of wavelengths, an Adcock array may be operated over more than one amateur band.

The response of the Adcock array to vertically polarized waves is similar to a conventional loop, and the directive pattern is essentially the same. Response of the array to a horizontally polarized wave is considerably different from that of a loop, however. The currents induced in the horizontal members tend to balance out regardless of the orientation of the antenna. This effect has been verified in practice, where good nulls were obtained with an

experimental Adcock under sky-wave conditions. The same circumstances produced poor nulls with small loops (both conventional and ferrite-loop models).

Generally speaking, the Adcock antenna has attractive properties for amateur RDF applications. Unfortunately, its portability leaves something to be desired, making it more suitable to fixed or semi-portable applications. While a metal support for the mast and boom could be used, wood, PVC or fiberglass are preferable because they are nonconductors and would therefore cause less pattern distortion.

Since the array is balanced, an antenna tuner is required to match the unbalanced input of a typical receiver. Fig 8 shows a suitable link-coupled network. C2 and C3 are null-balancing capacitors. A low-power signal source is placed some distance from the Adcock antenna and broadside to it. C2 and C3 are then adjusted until the deepest null is obtained. The tuner can be placed below the wiring-harness junction on the boom. Connection can be made by means of a short length of  $300\text{-}\Omega$  twin-lead.

The radiation pattern of the Adcock is shown in Fig 9A. The nulls are in directions broadside to the array, and become sharper with greater element spacings. However, with an element spacing greater than  $0.75 \lambda$ , the pattern begins to take on additional nulls in the directions off the ends of the array axis. At a spacing of  $1 \lambda$  the pattern is that of Fig 9B, and the array is unsuitable for RDF applications.

Short vertical monopoles are often used in what is sometimes called the *U-Adcock*, so named because the elements with their feeders take on the shape of the letter U. In this arrangement the elements are worked against the earth as a ground or counterpoise. If the array is used only for reception, earth losses are of no great consequence. Short, elevated vertical dipoles are also used in what is sometimes called the *H-Adcock*.

The Adcock array, with two nulls in its pattern, has the same ambiguity as the loop and the loopstick. Adding a sensing element to the Adcock array has not met with great

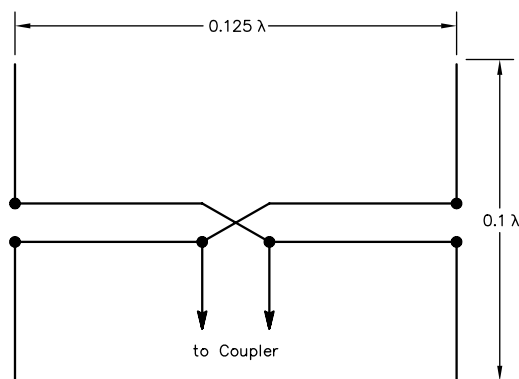


Fig 7—A simple Adcock antenna.

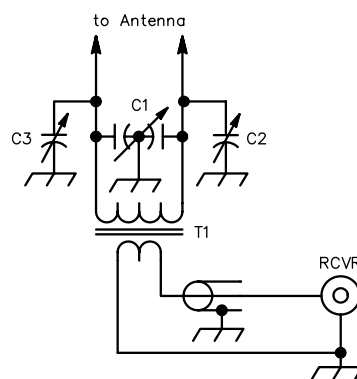
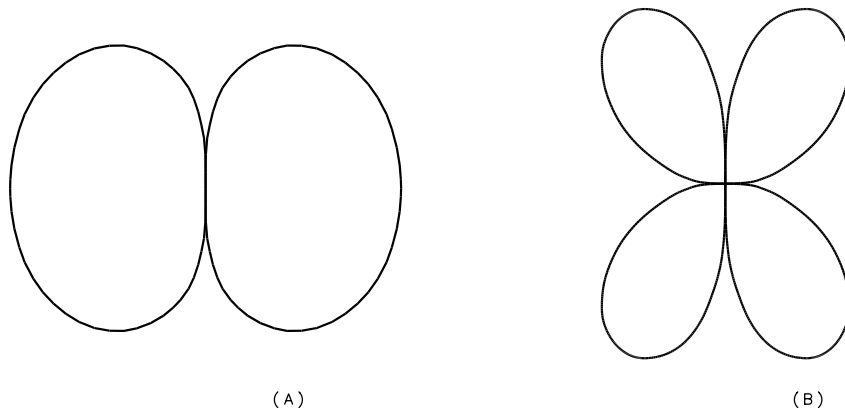


Fig 8—A suitable coupler for use with the Adcock antenna.



**Fig 9—At A, the pattern of the Adcock array with an element spacing of  $\frac{1}{2}$  wavelength. In these plots the elements are aligned with the horizontal axis. As the element spacing is increased beyond  $\frac{3}{4}$  wavelength, additional nulls develop off the ends of the array, and at a spacing of 1 wavelength the pattern at B exists. This pattern is unsuitable for RDF work.**

success. Difficulties arise from mutual coupling between the array elements and the sensing element, among other things. Because Adcock arrays are used primarily for fixed-station applications, the ambiguity presents no serious problem. The fixed station is usually one of a group of stations in an RDF network.

### LOOPS VERSUS PHASED ARRAYS

Although loops can be made smaller than suitable phased arrays for the same frequency of operation, the phased arrays are preferred by some for a variety of reasons. In general, sharper nulls can be obtained with phased arrays, but this is also a function of the care used in constructing and feeding the individual antennas, as well as of the size of the phased array in terms of wavelengths. The primary constructional consideration is the shielding and balancing of the feed line against unwanted signal pickup, and the balancing of the antenna for a symmetrical pattern.

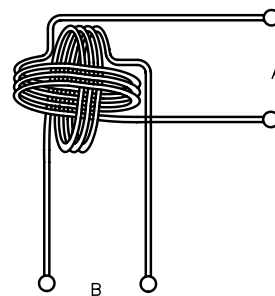
Loops are not as useful for skywave RDF work because of random polarization of the received signal. Phased arrays are somewhat less sensitive to propagation effects, probably because they are larger for the same frequency of operation and therefore offer some space diversity. In general, loops and loopsticks are used for mobile and portable operation, while phased arrays are used for fixed-station operation. However, phased arrays are used successfully above 144 MHz for portable and mobile RDF work. Practical examples of both types of antennas are presented later in this chapter.

### THE GONIOMETER

Most fixed RDF stations for government and commercial work use antenna arrays of stationary elements, rather than mechanically rotatable arrays. This has been true

since the earliest days of radio. The early-day device that permits finding directions without moving the elements is called a *radiogoniometer*, or simply a *goniometer*. Various types of goniometers are still used today in many installations, and offer the amateur some possibilities.

The early style of goniometer is a special form of RF transformer, as shown in **Fig 10**. It consists of two fixed coils mounted at right angles to one another. Inside the fixed coils is a movable coil, not shown in Fig 10 to avoid cluttering the diagram. The pairs of connections marked A and B are connected respectively to two elements in an array, and the output to the detector or receiver is taken from the movable coil. As the inner coil is rotated, the coupling to one fixed coil increases while that to the other decreases.



**Fig 10—An early type of goniometer that is still used today in some RDF applications. This device is a special type of RF transformer that permits a movable coil in the center (not shown here) to be rotated and determine directions even though the elements are stationary.**

Both the amplitude and the phase of the signal coupled into the pickup winding are altered with rotation in a way that corresponds to actually rotating the array itself. Therefore, the rotation of the inner coil can be calibrated in degrees to correspond to bearing angles from the station location.

In the early days of radio, the type of goniometer just described saw frequent use with fixed Adcock arrays. A refinement of that system employed four Adcock elements, two arrays at right angles to each other. With a goniometer arrangement, RDF measurements could be taken in all compass directions, as opposed to none off the ends of a two-element fixed array. However, resolution of the 4-element system was not as good as with a single pair of elements, probably because of mutual coupling among the elements. To overcome this difficulty a few systems of eight elements were installed.

Various other types of goniometers have been developed over the years, such as commutator switching to various elements in the array. A later development is the diode switching of capacitors to provide a commutator effect. As mechanical action has gradually been replaced with electronics to “rotate” stationary elements, the word goniometer is used less frequently these days. However, it still appears in many engineering reference texts. The more complex electronic systems of today are called *beam-forming networks*.

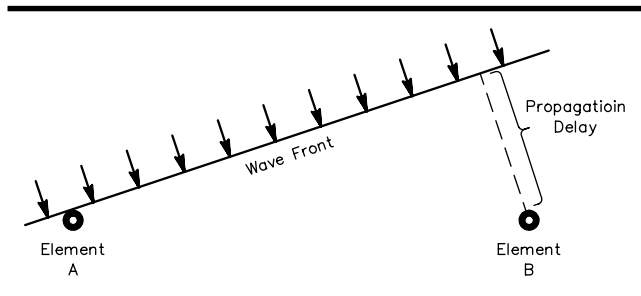
### Electronic Antenna Rotation

With an array of many fixed elements, beam rotation can be performed electronically by sampling and combining signals from various individual elements in the array. Contingent upon the total number of elements in the system and their physical arrangement, almost any desired antenna pattern can be formed by summing the sampled signals in appropriate amplitude and phase relationships. Delay networks are used for some of the elements before the summation is performed. In addition, attenuators may be used for some elements to develop patterns such as from an array with binomial current distribution.

One system using these techniques is the *Wullenweber* antenna, employed primarily in government and military installations. The Wullenweber consists of a very large number of elements arranged in a circle, usually outside of (or in front of) a circular reflecting screen. Depending on the installation, the circle may be anywhere from a few hundred feet to more than a quarter of a mile in diameter. Although the Wullenweber is not one that would be constructed by an amateur, some of the techniques it uses may certainly be applied to Amateur Radio.

For the moment, consider just two elements of a Wullenweber antenna, shown as A and B in **Fig 11**. Also shown is the wavefront of a radio signal arriving from a distant transmitter. As drawn, the wavefront strikes element A first, and must travel somewhat farther before it strikes element B. There is a finite time delay before the wavefront reaches element B.

The propagation delay may be measured by delaying



**Fig 11—This diagram illustrates one technique used in electronic beam forming. By delaying the signal from element A by an amount equal to the propagation delay, the two signals may be summed precisely in phase, even though the signal is not in the broadside direction. Because this time delay is identical for all frequencies, the system is not frequency sensitive.**

the signal received at element A before summing it with that from element B. If the two signals are combined directly, the amplitude of the resultant signal will be maximum when the delay for element A exactly equals the propagation delay. This results in an in-phase condition at the summation point. Or if one of the signals is inverted and the two are summed, a null will exist when the element-A delay equals the propagation delay; the signals will combine in a 180° out-of-phase relationship. Either way, once the time delay is known, it may be converted to distance. Then the direction from which the wave is arriving may be determined by trigonometry.

By altering the delay in small increments, the peak of the antenna lobe (or the null) can be steered in azimuth. This is true without regard to the frequency of the incoming wave. Thus, as long as the delay is less than the period of one RF cycle, the system is not frequency sensitive, other than for the frequency range that may be covered satisfactorily by the array elements themselves. Surface acoustic wave (SAW) devices or lumped-constant networks can be used for delay lines in such systems if the system is used only for receiving. Rolls of coaxial cable of various lengths are used in installations for transmitting. In this case, the lines are considered for the time delay they provide, rather than as simple phasing lines. The difference is that a phasing line is ordinarily designed for a single frequency (or for an amateur band), while a delay line offers essentially the same time delay at all frequencies.

By combining signals from other Wullenweber elements appropriately, the broad bandwidth of the pattern from the two elements can be narrowed, and unwanted sidelobes can be suppressed. Then, by electronically switching the delays and attenuations to the various elements, the beam so formed can be rotated around the compass. The package of electronics designed to do this, including delay lines and electronically switched attenuators, is the beam-forming network. However, the Wullenweber system is not

restricted to forming a single beam. With an isolation amplifier provided for each element of the array, several beam-forming networks can be operated independently. Imagine having an antenna system that offers a dipole pattern, a rhombic pattern, and a Yagi beam pattern, all simultaneously and without frequency sensitivity. One or more may be rotating while another is held in a particular direction. The Wullenweber was designed to fulfill this type of requirement.

One feature of the Wullenweber antenna is that it can operate 360° around the compass. In many government installations, there is no need for such coverage, as the areas of interest lie in an azimuth sector. In such cases an in-line array of elements with a backscreen or curtain reflector may be installed broadside to the center of the sector. By using the same techniques as the Wullenweber, the beams formed from this array may be slewed left and right across the sector. The maximum sector width available will depend on the installation, but beyond 70° to 80° the patterns begin to deteriorate to the point that they are unsatisfactory for precise RDF work.

### RDF SYSTEM CALIBRATION AND USE

Once an RDF system is initially assembled, it should be calibrated or checked out before actually being put into use. Of primary concern is the balance or symmetry of the antenna pattern. A lop-sided figure-8 pattern with a loop, for example, is undesirable; the nulls are not 180° apart, nor are they at exact right angles to the plane of the loop. If you didn't know this fact in actual RDF work, measurement accuracy would suffer.

Initial checkout can be performed with a low-powered transmitter at a distance of a few hundred feet. It should be within visual range and must be operating into a vertical antenna. (A quarter-wave vertical or a loaded whip is quite suitable.) The site must be reasonably clear of obstructions, especially steel and concrete or brick buildings, large metal objects, nearby power lines, and so on. If the system operates above 30 MHz, you should also avoid trees and large bushes. An open field makes an excellent site.

The procedure is to find the transmitter with the RDF equipment as if its position were not known, and compare the RDF null indication with the visual path to the transmitter. For antennas having more than one null, each null should be checked.

If imbalance is found in the antenna system, there are two options available. One is to correct the imbalance. Toward this end, pay particular attention to the feed line. Using a coaxial feeder for a balanced antenna invites an asymmetrical pattern, unless an effective balun is used. A balun is not necessary if the loop is shielded, but an asymmetrical pattern can result with misplacement of the break in the shield itself. The builder may also find that the presence of a sensing antenna upsets the balance slightly, due to mutual coupling. Experiment with its position with respect to the main antenna to correct the error. You will

also note that the position of the null shifts by 90° as the sensing element is switched in and out, and the null is not as deep. This is of little concern, however, as the intent of the sensing antenna is only to resolve ambiguities. The sensing element should be switched out when accuracy is desired.

The second option is to accept the imbalance of the antenna and use some kind of indicator to show the true directions of the nulls. Small pointers, painted marks on the mast, or an optical sighting system might be used. Sometimes the end result of the calibration procedure will be a compromise between these two options, as a perfect electrical balance may be difficult or impossible to attain.

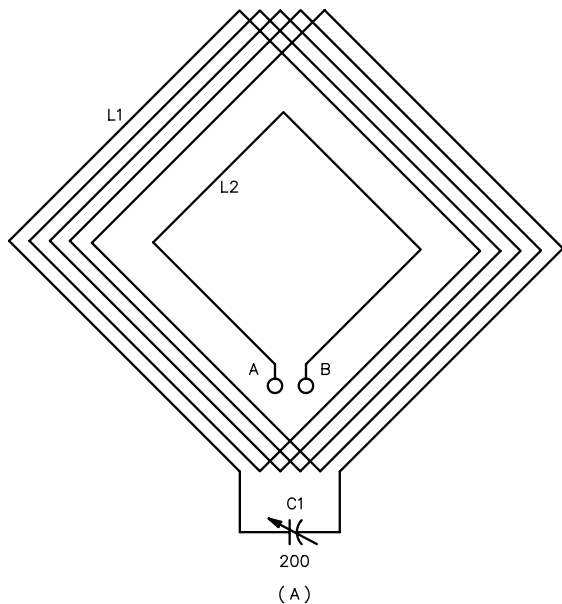
The discussion above is oriented toward calibrating portable RDF systems. The same general suggestions apply if the RDF array is fixed, such as an Adcock. However, it won't be possible to move it to an open field. Instead, the array must be calibrated in its intended operating position through the use of a portable or mobile transmitter. Because of nearby obstructions or reflecting objects, the null in the pattern may not appear to indicate the precise direction of the transmitter. Do not confuse this with imbalance in the RDF array. Check for imbalance by rotating the array 180° and comparing readings.

Once the balance is satisfactory, you should make a table of bearing errors noted in different compass directions. These error values should be applied as corrections when actual measurements are made. The mobile or portable transmitter should be at a distance of two or three miles for these measurements, and should be in as clear an area as possible during transmissions. The idea is to avoid conduction of the signal along power lines and other overhead wiring from the transmitter to the RDF site. Of course the position of the transmitter must be known accurately for each transmission.

### FRAME LOOPS

It was mentioned earlier that the earliest style of receiving loops was the frame antenna. If carefully constructed, such an antenna performs well and can be built at low cost. [Fig 12](#) illustrates the details of a practical frame type of loop antenna. This antenna was designed by [Doug DeMaw, W1FB](#), and described in *QST* for July 1977. (See the Bibliography at the end of this chapter.) The circuit in [Fig 12A](#) is a 5-turn system tuned to resonance by C1. If the layout is symmetrical, good balance should be obtained. L2 helps to achieve this objective by eliminating the need for direct coupling to the feed terminals of L1. If the loop feed were attached in parallel with C1, a common practice, the chance for imbalance would be considerable.

L2 can be situated just inside or slightly outside of L1; a 1-inch separation works nicely. The receiver or preamplifier can be connected to terminals A and B of L2, as shown in [Fig 12B](#). C2 controls the amount of coupling between the loop and the preamplifier. The lighter the coupling, the higher is the loop Q, the narrower is the frequency response, and the greater is the gain requirement from the preamplifier. It



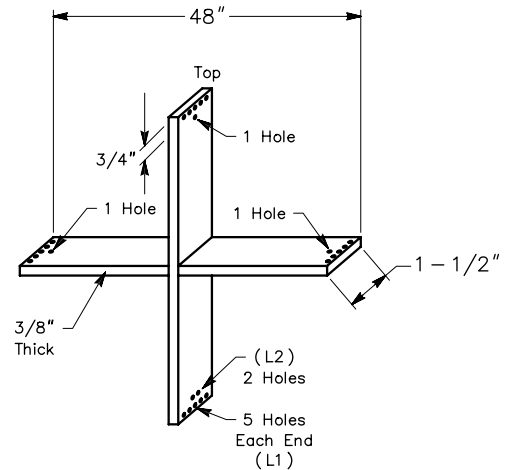
**Fig 12—A multitransform frame antenna is shown at A. L2 is the coupling loop. The drawing at B shows how L2 is connected to a preamplifier.**

should be noted that no attempt is being made to match the extremely low loop impedance to the preamplifier.

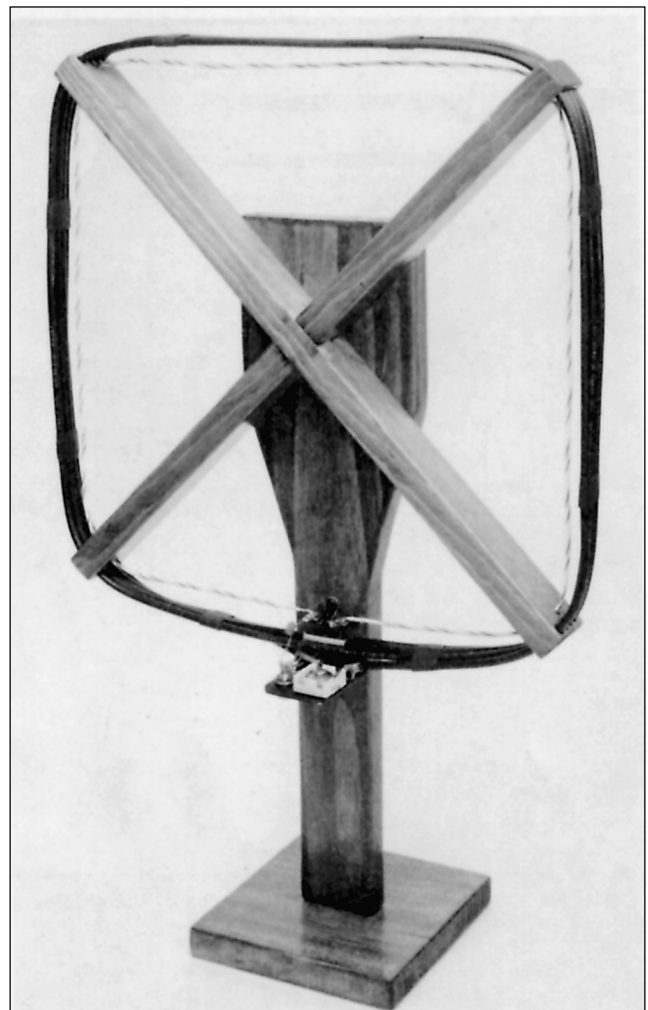
A supporting frame for the loop of Fig 12 can be constructed of wood, as shown in Fig 13. The dimensions given are for a 1.8-MHz frame antenna. For use on 75 or 40 meters, L1 of Fig 12A will require fewer turns, or the size of the wooden frame should be made somewhat smaller than that of Fig 13.

### SHIELDED FRAME LOOPS

If electrostatic shielding is desired, the format shown in Fig 14 can be adopted. In this example, the loop conductor and the single-turn coupling loop are made from RG-58 coaxial cable. The number of loop turns should be sufficient to resonate with the tuning capacitor at the operating frequency. Antenna resonance can be checked by first connecting C1 (Fig 12A) and setting it at midrange. Then connect a small 3-turn coil to the loop feed terminals, and couple to it with a dip meter. Just remember that the pickup coil will act to lower the frequency slightly from actual resonance.



**Fig 13—A wooden frame can be used to contain the wire of the loop shown in Fig 12.**



**Fig 14—An assembled table-top version of the electrostatically shielded loop. RG-58 cable is used in its construction.**

In the antenna photographed for Fig 14, the 1-turn coupling loop was made of #22 plastic-insulated wire. However, electrostatic noise pickup occurs on such a coupling loop, noise of the same nature that the shield on the main loop prevents. This can be avoided by using RG-58 for the coupling loop. The shield of the coupling loop should be opened for about 1 inch at the top, and each end of the shield grounded to the shield of the main loop.

Larger single-turn frame loops can be fashioned from aluminum-jacketed Hardline, if that style of coax is available. In either case, the shield conductor must be opened at the electrical center of the loop, as shown in Fig 15 at A and B. The design example is for 1.8-MHz operation.

To realize the best performance from an electrostatically shielded loop antenna, you must operate it near to and directly above an effective ground plane. An automobile roof (metal) qualifies nicely for small shielded loops. For fixed-station use, a chicken-wire ground screen can be placed below the antenna at a distance of 1 to 6 feet.

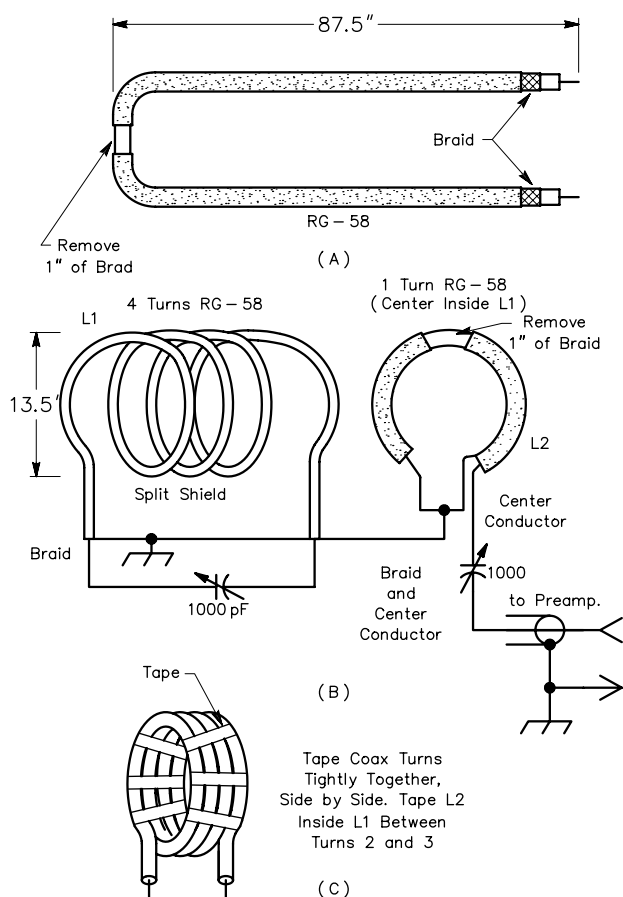


Fig 15—Components and assembly details of the shielded loop shown in Fig 14.

## FERRITE-CORE LOOPS

Fig 16 contains a diagram for a rod loop (loopstick antenna). This antenna was also designed by Doug DeMaw, W1FB, and described in *QST* for July 1977. The winding (L1) has the appropriate number of turns to permit resonance with C1 at the operating frequency. L1 should be spread over approximately 1/3 of the core center. Litz wire will yield the best Q, but Formvar magnet wire can be used if desired. A layer of 3M Company glass tape (or Mylar tape) is recommended as a covering for the core before adding the wire. Masking tape can be used if nothing else is available.

L2 functions as a coupling link over the exact center of L1. C1 is a dual-section variable capacitor, although a differential capacitor might be better toward obtaining optimum balance. The loop Q is controlled by means of C2, which is a mica-compression trimmer.

Electrostatic shielding of rod loops can be effected by centering the rod in a U-shaped aluminum, brass or copper channel, extending slightly beyond the ends of the rod loop (1 inch is suitable). The open side (top) of the channel can't be closed, as that would constitute a shorted turn and render the antenna useless. This can be proved by shorting across the center of the channel with a screwdriver blade when the loop is tuned to an incoming signal. The shield-braid gap in the coaxial loop of Fig 15 is maintained for the same reason.

Fig 17 shows the shielded rod loop assembly. This antenna was developed experimentally for 160 meters and

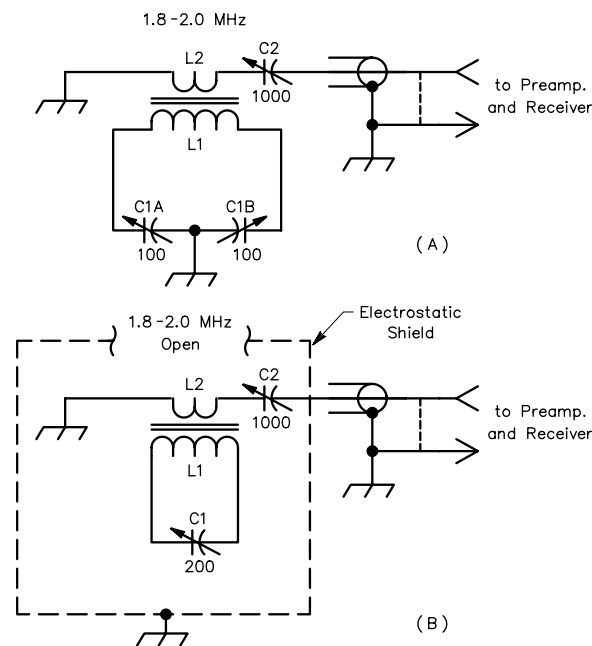
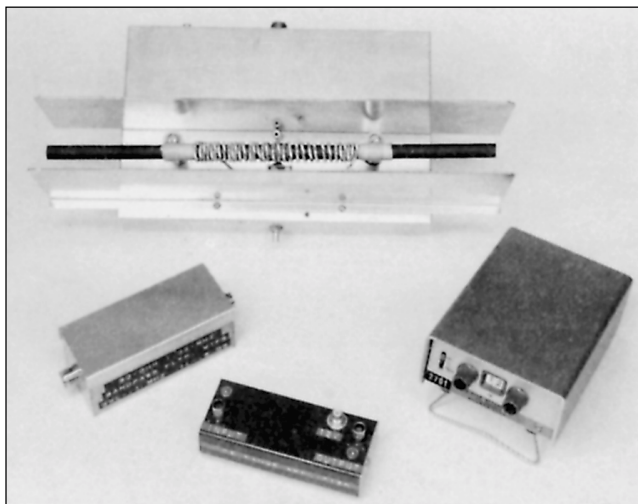


Fig 16—At A, the diagram of a ferrite loop. C1 is a dual-section air-variable capacitor. The circuit at B shows a rod loop contained in an electrostatic shield (see text). A suitable low-noise preamplifier is shown in Fig 19.



**Fig 17**—The assembly at the top of the picture is a shielded ferrite-rod loop for 160 meters. Two rods have been glued end to end (see text). The other units in the picture are a low-pass filter (lower left), broadband preamplifier (lower center) and a Tektronix step attenuator (lower right). These were part of the test setup used when the antenna was evaluated.

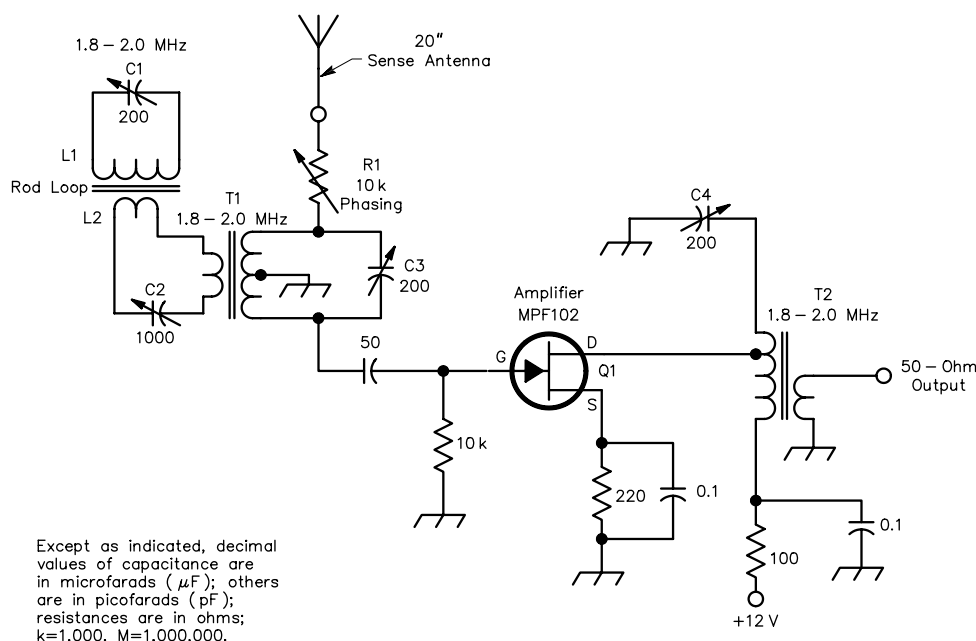
uses two 7-inch ferrite rods, glued together end-to-end with epoxy cement. The longer core resulted in improved sensitivity for weak-signal reception. The other items in the photograph were used during the evaluation tests and are not pertinent to this discussion. This loop and the frame loop discussed in the previous section have bidirectional nulls, as shown in Fig 1A.

## Obtaining a Cardioid Pattern

Although the bidirectional pattern of loop antennas can be used effectively in tracking down signal sources by means of triangulation, an essentially unidirectional loop response will help to reduce the time spent finding the fox. Adding a sensing antenna to the loop is simple to do, and it will provide the desired cardioid response. The theoretical pattern for this combination is shown in Fig 1D.

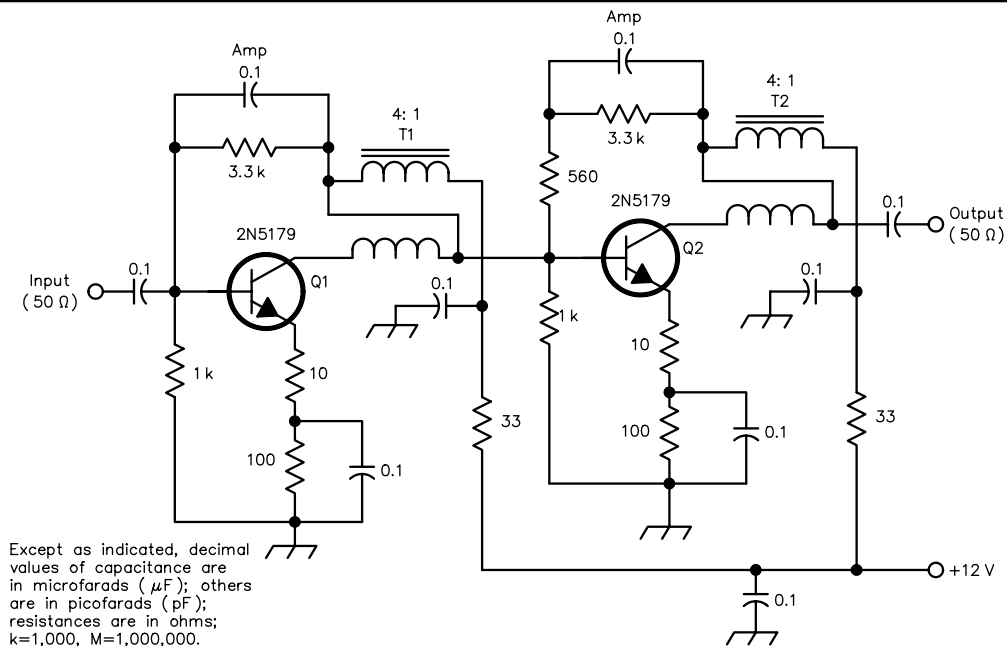
**Fig 18** shows how a sensing element can be added to a loop or loopstick antenna. The link from the loop is connected by coaxial cable to the primary of T1, which is a tuned toroidal transformer with a split secondary winding. C3 is adjusted for peak signal response at the frequency of interest (as is C4), then R1 is adjusted for minimum back response of the loop. It will be necessary to readjust C3 and R1 several times to compensate for the interaction of these controls. The adjustments are repeated until no further null depth can be obtained. Tests at ARRL Headquarters showed that null depths as great as 40 dB could be obtained with the circuit of Fig 18 on 75 meters. A near-field weak-signal source was used during the tests.

The greater the null depth, the lower the signal output from the system, so plan to include a preamplifier with 25 to 40 dB of gain. Q1 shown in Fig 18 will deliver approximately 15 dB of gain. The circuit of Fig 19 can be used following T2 to obtain an additional 24 dB of gain. In the interest of maintaining a good noise figure, even at 1.8 MHz, Q1 should be a low-noise device. A 2N4416, an MPF102, or a 40673 MOSFET would be satisfactory. The sensing antenna can be mounted 6 to 15 inches from the loop. The vertical whip need not be more than 12 to 20 inches



**Fig 18**—Schematic diagram of a rod-loop antenna with a cardioid response. The sensing antenna, phasing network and a preamplifier are shown also. The secondary of T1 and the primary of T2 are tuned to resonance at the operating frequency of the loop. T-68-2 to T-68-6 Amidon toroid cores are suitable for both transformers. Amidon also sells ferrite rods for this type of antenna.

Except as indicated, decimal values of capacitance are in microfarads ( $\mu\text{F}$ ); others are in picofarads (pF); resistances are in ohms; k=1,000, M=1,000,000.



**Fig 19—Schematic diagram of a two-stage broadband amplifier patterned after a design by Wes Hayward, W7ZOI. T1 and T2 have a 4:1 impedance ratio and are wound on FT-50-61 toroid cores (Amidon) which have a  $\mu_i$  of 125. They contain 12 turns of #24 enamel wire, bifilar wound. The capacitors are disc ceramic. This amplifier should be built on double-sided circuit board for best stability.**

long. Some experimenting may be necessary in order to obtain the best results. Optimization will also change with the operating frequency of the antenna.

### A SHIELDED LOOP WITH SENSING ANTENNA FOR 28 MHz

**Fig 20** shows the construction and mounting of a simple shielded 10-meter loop. The loop was designed by **Loren Norberg, W9PYG**, and described in *QST* for April 1954. (See the Bibliography at the end of this chapter.) It is made from an 18-inch length of RG-11 coax (either solid or foam dielectric) secured to an aluminum box of any convenient size, with two coaxial cable hoods (Amphenol 83-1HP). The outer shield must be broken at the exact center. C1 is a 25-pF variable capacitor, and is connected in parallel with a 33-pF fixed mica padder capacitor, C3. C1 must be tuned to the desired frequency while the loop is connected to the receiver in the same way as it will be used for RDF. C2 is a small differential capacitor used to provide electrical symmetry. The lead-in to the receiver is 67 inches of RG-59 (82 inches if the cable has a foamed dielectric).

The loop can be mounted on the roof of the car with a rubber suction cup. The builder might also fabricate some kind of bracket assembly to mount the loop temporarily in the window opening of the automobile, allowing for loop rotation. Reasonably true bearings may be obtained through the windshield when the car is pointed in the direction of the hidden transmitter. More accurate bearings may be

obtained with the loop held out the window and the signal coming toward that side of the car.

Sometimes the car broadcast antenna may interfere with accurate bearings. Disconnecting the antenna from the broadcast receiver may eliminate this trouble.

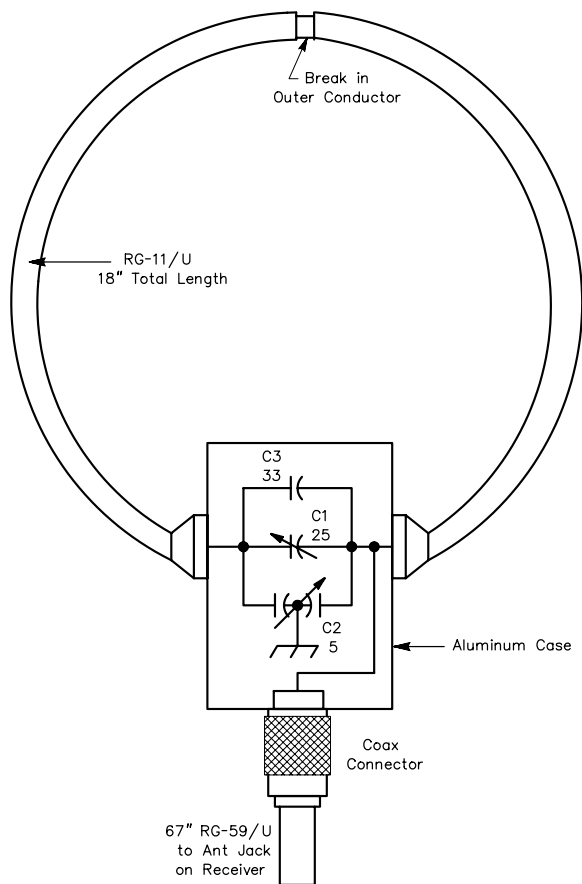
### Sensing Antenna

A sensing antenna can be added to Norberg's loop above to determine which of the two directions indicated by the loop is the correct one. Add a phono jack to the top of the aluminum case shown in **Fig 20**. The insulated center terminal of the jack should be connected to the side of the tuning capacitors that is common to the center conductor of the RG-59 coax feed line. The jack then takes a short vertical antenna rod of the diameter to fit the jack, or a piece of #12 or #14 solid wire may be soldered to the center pin of a phono plug for insertion in the jack. The sensing antenna can be plugged in as needed. Starting with a length of about four times the loop diameter, the length of the sensing antenna should be pruned until the pattern is similar to that of **Fig 1D**.

### THE SNOOP LOOP—FOR CLOSE-RANGE HF RDF

Picture yourself on a hunt for a hidden 28-MHz transmitter. The night is dark, very dark. After you take off at the start of the hunt, heading in the right direction, the signal gets stronger and stronger. Your excitement increases with each additional S unit on the meter. You follow your





**Fig 20—Sketch showing the constructional details of the 28-MHz RDF loop. The outer braid of the coax loop is broken at the center of the loop. The gap is covered with waterproof tape, and the entire assembly is given a coat of acrylic spray.**

loop closely, and it is working perfectly. You're getting out of town and into the countryside. The roads are unfamiliar. Now the null is beginning to swing rather rapidly, showing that you are getting close.

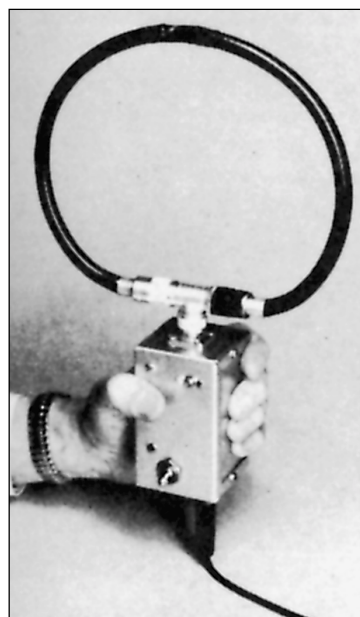
Suddenly the null shifts to give a direction at right angles to the car. With your flashlight you look carefully across the deep ditch beside the road and into the dark field where you know the transmitter is hidden. There are no roads into the field as far as you can see in either direction. You dare not waste miles driving up and down the road looking for an entrance, for each tenth of a mile counts. But what to do?—Your HF transceiver is mounted in your car and requires power from your car battery.

In a brief moment your decision is made. You park beside the road, take your flashlight, and plunge into the veldt in the direction your loop null clearly indicated. But after taking a few steps, you're up to your armpits in brush and can't see anything forward or backward. You stumble on in hopes of running into the hidden transmitter—you're

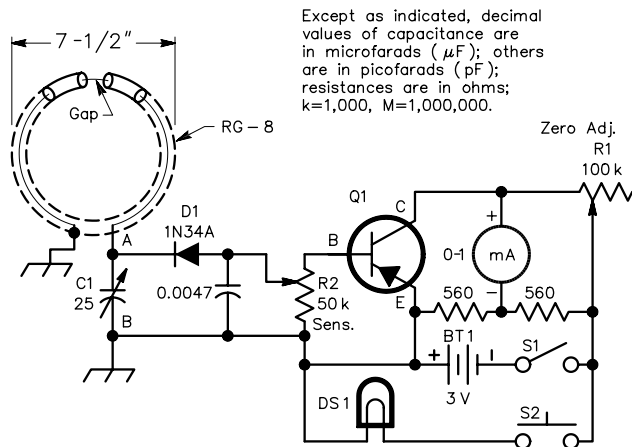
probably not more than a few hundred feet from it. But away from your car and radio equipment, it's like the proverbial hunt for the needle in the haystack. What you really need is a portable setup for hunting at close range, and you may prefer something that is inexpensive. The Snoop Loop was designed for just these requirements by [Claude Maer, Jr, W0IC](#), and was described in *QST* for February 1957. (See the Bibliography at the end of this chapter.)

The Snoop Loop is pictured in **Fig 21**. The loop itself is made from a length of RG-8 coax, with the shield broken at the top. A coax T connector is used for convenience and ease of mounting. One end of the coax loop is connected to a male plug in the conventional way, but the center conductor of the other end is shorted to the shield so the male connector at that end has no connection to the center prong. This results in an unbalanced circuit, but seems to give good bidirectional null readings, as well as an easily detectable maximum reading when the grounded end of the loop is pointed in the direction of the transmitter. Careful tuning with C1 will improve this maximum reading. Don't forget to remove one inch of shielding from the top of the loop. You won't get much signal unless you do.

The detector and amplifier circuit for the Snoop Loop is shown in **Fig 22**. The model photographed does not include the meter, as it was built for use only with high-impedance headphones. The components are housed in an aluminum box. Almost any size box of sufficient size to contain the



**Fig 21—The box containing the detector and amplifier is also the "handle" for the Snoop Loop. The loop is mounted with a coax T as a support, a convenience but not an essential part of the loop assembly. The loop tuning capacitor is screwdriver adjusted. The on-off switch and the meter sensitivity control may be mounted on the bottom.**



Except as indicated, decimal values of capacitance are in microfarads ( $\mu\text{F}$ ); others are in picofarads (pF); resistances are in ohms; k=1,000, M=1,000,000.

**Fig 22—The Snoop Loop circuit for 28-MHz operation.** The loop is a single turn of RG-8 inner conductor, the outer conductor being used as a shield. Note the gap in the shielding; about a 1-inch section of the outer conductor should be cut out. Refer to Fig 23 for alternative connection at points A and B for other frequencies of operation.

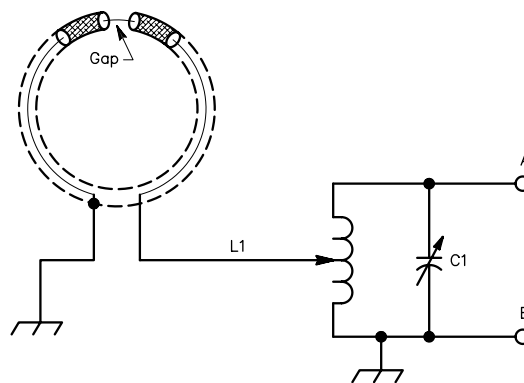
- BT1—Two penlight cells.
- C1—25-pF midget air padder.
- D1—Small-signal germanium diode such as 1N34A or equiv.
- DS1—Optional 2-cell penlight lamp for meter illumination, such as no. 222.
- Q1—PNP transistor such as ECG102 or equiv.
- R1—100-k $\Omega$  potentiometer, linear taper. May be PC-mount style.
- R2—50-k $\Omega$  potentiometer, linear taper.
- S1—SPST toggle.
- S2—Optional momentary push for illuminating meter.

meter can be used. At very close ranges, reduction of sensitivity with R2 will prevent pegging the meter.

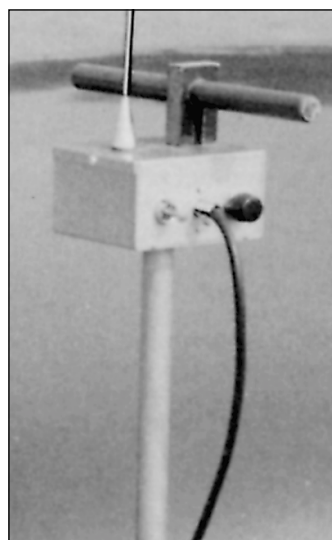
The Snoop Loop is not limited to the 10-meter band or to a built-in loop. Fig 23 shows an alternative circuit for other bands and for plugging in a separate loop connected by a low-impedance transmission line. Select coil and capacitor combinations that will tune to the desired frequencies. Plug-in coils could be used. It is a good idea to have the RF end of the unit fairly well shielded, to eliminate signal pickup except through the loop. This little unit should certainly help you on those dark nights in the country. (Tip to the hidden-transmitter operator—if you want to foul up some of your pals using these loops, just hide near the antenna of a 50-kW broadcast transmitter!)

### A LOOPSTICK FOR 3.5 MHz

Figs 24, 25 and 26 show an RDF loop suitable for the 3.5-MHz band. It uses a construction technique that has had considerable application in low-frequency marine direction finders. The loop is a coil wound on a ferrite rod from a broadcast-antenna loopstick. The loop was designed by John



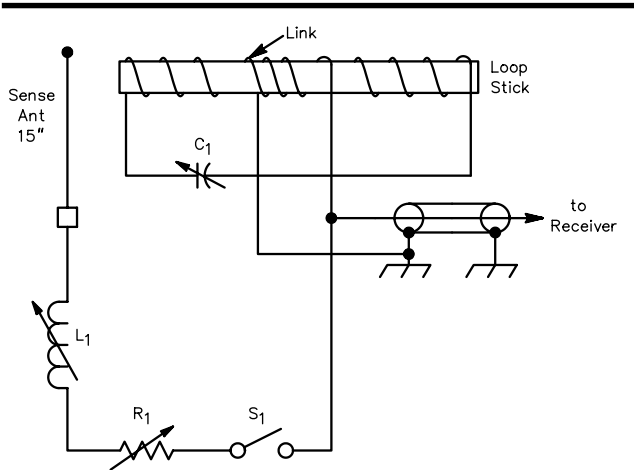
**Fig 23—Input circuit for lower frequency bands.** Points A and B are connected to corresponding points in the circuit of Fig 22, substituting for the loop and C1 in that circuit. L1-C1 should resonate within the desired amateur band, but the L/C ratio is not critical. After construction is completed, adjust the position of the tap on L1 for maximum signal strength. Instead of connecting the RDF loop directly to the tap on L1, a length of low impedance line may be used between the loop and the tuned circuit, L1-C1.



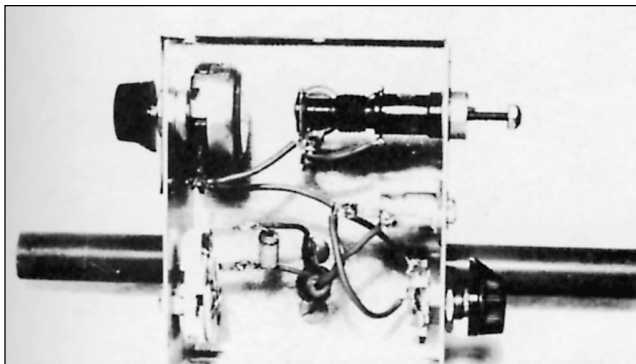
**Fig 24—Unidirectional 3.5-MHz RDF using ferrite-core loop with sensing antenna.** Adjustable components of the circuit are mounted in the aluminum chassis supported by a short length of tubing.

Isaacs, W6PZV, and described in *QST* for June 1958. Because you can make a coil with high Q using a ferrite core, the sensitivity of such a loop is comparable to a conventional loop that is a foot or so in diameter. The output of the vertical-rod sensing antenna, when properly combined with that of the loop, gives the system the cardioid pattern shown in Fig 1D.

To make the loop, remove the original winding on the ferrite core and wind a new coil, as shown in Fig 25. Other



**Fig 25—Circuit of the 3.5-MHz direction finder loop.**  
**C1**—140 pF variable (125-pF ceramic trimmer in parallel with 15-pF ceramic fixed).  
**L1**—Approximately 140  $\mu$ H adjustable (Miller No. 4512 or equivalent).  
**R1**—1-k $\Omega$  carbon potentiometer.  
**S1**—SPST toggle.  
**Loopstick**—Approximately 15  $\mu$ H (Miller 705-A, with original winding removed and wound with 20 turns of #22 enamel). Link is two turns at center. Winding ends secured with Scotch electrical tape. This type of ferrite rod may also be found in surplus transistor AM radios.



**Fig 26—Components of the 3.5-MHz RDF are mounted on the top and sides of a channel-lock type box. In this view R1 is on the left wall at the upper left and C1 is at the lower left. L1, S1 and the output connector are on the right wall. The loopstick and whip mount on the outside.**

types of cores than the one specified may be substituted; use the largest coil available and adjust the winding so that the circuit resonates in the 3.5-MHz band within the range of C1. The tuning range of the loop may be checked with a dip meter.

The sensing system consists of a 15-inch whip and an adjustable inductor that resonates the whip as a quarter-wave antenna. It also contains a potentiometer to control the output of the antenna. S1 is used to switch the sensing antenna in and out of the circuit.

The whip, the loopstick, the inductance L1, the capacitor C1, the potentiometer R1, and the switch S1 are all mounted on a 4  $\times$  5  $\times$  3-inch box chassis, as shown in **Fig 26**. The loopstick may be mounted and protected inside a piece of 1/2-inch PVC pipe. A section of 1/2-inch electrical conduit is attached to the bottom of the chassis box and this supports the instrument.

To produce an output having only one null there must be a 90° phase difference between the outputs of the loop and sensing antennas, and the signal strength from each must be the same. The phase shift is obtained by tuning the sensing antenna slightly off frequency, using the slug in L1. Since the sensitivity of the whip antenna is greater than that of the loop, its output is reduced by adjusting R1.

### Adjustment

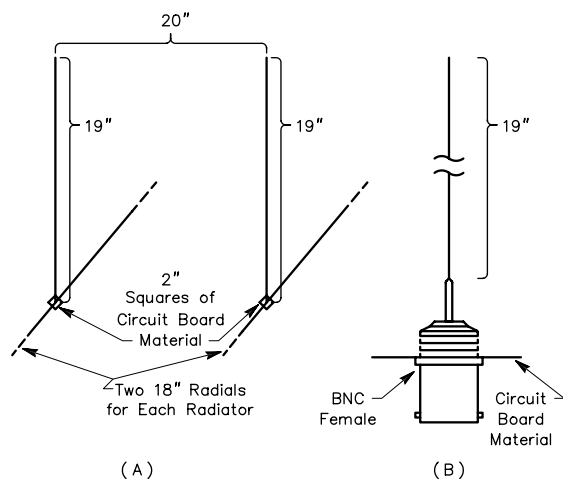
To adjust the system, enlist the aid of a friend with a mobile transmitter and find a clear spot where the transmitter and RDF receiver can be separated by several hundred feet. Use as little power as possible at the transmitter. (Make very sure you don't transmit into the loop if you are using a transceiver as a detector.) With the test transmitter operating on the proper frequency, disconnect the sensing antenna with S1, and peak the loopstick using C1, while watching the S meter on the transceiver. Once the loopstick is peaked, no further adjustment of C1 will be necessary. Next, connect the sensing antenna and turn R1 to minimum resistance. Then vary the adjustable slug of L1 until a maximum reading of the S meter is again obtained. It may be necessary to turn the unit a bit during this adjustment to obtain a higher reading than with the loopstick alone. The last turn of the slug is quite critical, and some hand-capacitance effect may be noted.

Now turn the instrument so that one side (not an end) of the loopstick is pointed toward the test transmitter. Turn R1 a complete revolution and if the proper side was chosen a definite null should be observed on the S meter for one particular position of R1. If not, turn the RDF 180° and try again. This time leave R1 at the setting producing the minimum reading. Now adjust L1 very slowly until the S-meter reading is reduced still further. Repeat this several times, first R1, and then L1, until the best minimum is obtained.

Finally, as a check, have the test transmitter move around the RDF and follow it by turning the RDF. If the tuning has been done properly the null will always be broadside to the loopstick. Make a note of the proper side of the RDF for the null, and the job is finished.

### A 144-MHz CARIROID-PATTERN RDF ANTENNA

Although there may be any number of different VHF antennas that can produce a cardioid pattern, a simple design is depicted in **Fig 27**. Two 1/4-wavelength vertical elements are spaced one 1/4- $\lambda$  apart and are fed 90° out of phase. Each radiator is shown with two radials approximately 5% shorter than the radiators. This array was designed by **Pete O'Dell, KB1N**, and described in *QST* for March 1981.



**Fig 27—At A is a simple configuration that can produce a cardioid pattern. At B is a convenient way of fabricating a sturdy mount for the radiator using BNC connectors.**

Computer modeling showed that slight alterations in the size, spacing and phasing of the elements strongly impact the pattern. The results suggest that this system is a little touchy and that the most significant change comes at the null. Very slight alterations in the dimensions caused the notch to become much more shallow and, hence, less usable for RDF. Early experience in building a working model bore this out.

This means that if you build this antenna, you will find it advantageous to spend a few minutes to tune it carefully for the deepest null. If it is built using the techniques presented here, then this should prove to be a small task, well worth the extra effort. Tuning is accomplished by adjusting the length of the vertical radiators, the spacing between them and, if necessary, the lengths of the phasing harness that connects them. Tune for the deepest null on your S meter when using a signal source such as a moderately strong repeater.

This should be done outside, away from buildings and large metal objects. Initial indoor tuning on this project was tried in the kitchen, which revealed that reflections off the appliances were producing spurious readings. Beware too of distant water towers, radio towers, and large office or apartment buildings. They can reflect the signal and give false indications.

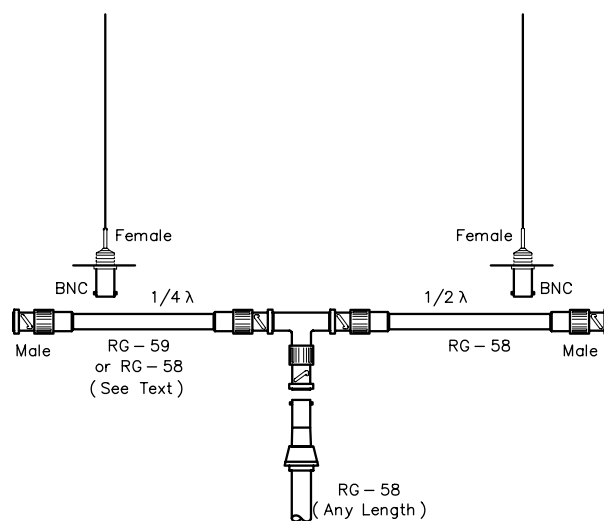
Construction is simple and straightforward. Fig 27B shows a female BNC connector (Radio Shack 278-105) that has been mounted on a small piece of PC-board material. The BNC connector is held upside down, and the vertical radiator is soldered to the center solder lug. A 12-inch piece of brass tubing provides a snug fit over the solder lug. A second piece of tubing, slightly smaller in diameter, is

telescoped inside the first. The outer tubing is crimped slightly at the top after the inner tubing is installed. This provides positive contact between the two tubes. For 146 MHz the length of the radiators is calculated to be about 19 inches. You should be able to find small brass tubing at a hobby store. If none is available in your area, consider brazing rods. These are often available in hardware sections of discount stores. It will probably be necessary to solder a short piece to the top since these come in 18-inch sections. Also, tuning will not be quite as convenient. Two 18-inch radials are added to each element by soldering them to the board. Two 36-inch pieces of heavy brazing rod were used in this project.

### The Phasing Harness

As shown in Fig 28, a T connector is used with two different lengths of coaxial line to form the phasing harness. This method of feeding the antenna is superior over other simple systems to obtain equal currents in the two radiators. Unequal currents tend to reduce the depth of the null in the pattern, all other factors being equal.

The  $\frac{1}{2}$ -wavelength section can be made from either RG-58 or RG-59, because it should act as a 1:1 transformer. With no radials or with two radials perpendicular to the vertical element, it was found that a  $\frac{1}{4}$ -wavelength section



**Fig 28—The phasing harness for the phased 144-MHz RDF array. The phasing sections must be measured from the center of the T connector to the point that the vertical radiator emerges from the shielded portion of the upside-down BNC female. Don't forget to take the length of the connectors into account when constructing the harness. If care is taken and coax with solid polyethylene dielectric is used, you should not have to prune the phasing line. With this phasing system, the null will be in a direction that runs along the boom, on the side of the  $\frac{1}{4}$ -wavelength section.**

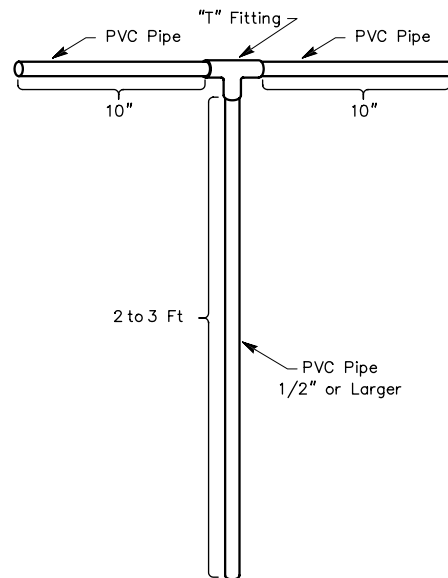
made of RG-59 75- $\Omega$  coax produced a deeper notch than a  $\frac{1}{4}$ -wavelength section made of RG-58 50- $\Omega$  line. However, with the two radials bent downward somewhat, the RG-58 section seemed to outperform the RG-59. Because of minor differences in assembly techniques from one antenna to another, it will probably be worth your time and effort to try both types of coax and determine what works best for your antenna. You may also want to try bending the radials down at slightly different angles for the best null performance.

The most important thing about the coax for the harness is that it be of the highest quality (well-shielded and with a polyethylene dielectric). The reason for avoiding foam dielectric is that the velocity factor can vary from one roll to the next—some say that it varies from one foot to the next. Of course, it can be used if you have test equipment available that will allow you to determine its electrical length. Assuming that you do not want to or cannot go to that trouble, stay with coax having a solid polyethylene dielectric. Avoid coax that is designed for the CB market or do-it-yourself cable-TV market. (A good choice is Belden 8240 for the RG-58 or Belden 8241 for the RG-59.)

Both RG-58 and RG-59 with polyethylene dielectric have a velocity factor of 0.66. Therefore, for 146 MHz a quarter wavelength of transmission line will be  $20.2 \text{ inches} \times 0.66 = 13.3 \text{ inches}$ . A half-wavelength section will be twice this length or 26.7 inches. One thing you must take into account is that the transmission line is the total length of the cable *and the connectors*. Depending on the type of construction and the type of connectors that you choose, the actual length of the coax by itself will vary somewhat. You will have to determine that for yourself.

Y connectors that mate with RCA phono plugs are widely available and the phono plugs are easy to work with. Avoid the temptation, however, to substitute these for the T and BNC connectors. Phono plugs and a Y connector were tried. The results with that system were not satisfactory. The performance seemed to change from day to day and the notch was never as deep as it should have been. Although they are more difficult to find, BNC T connectors will provide superior performance and are well worth the extra cost. If you must make substitutions, it would be preferable to use UHF connectors (type PL-259).

**Fig 29** shows a simple support for the antenna. PVC tubing is used throughout. Additionally, you will need a T fitting, two end caps, and possibly some cement. (By not cementing the PVC fittings together, you will have the option of disassembly for transportation.) Cut the PVC for the dimensions shown, using a saw or a tubing cutter. A tubing cutter is preferred because it produces smooth, straight edges without making a mess. Drill a small hole through the PC board near the female BNC of each element assembly. Measure the 20-inch distance horizontally along the boom and mark the two end points. Drill a small hole vertically through the boom at each mark. Use a small nut and bolt to attach each element assembly to the boom.



**Fig 29—A simple mechanical support for the DF antenna, made of PVC pipe and fittings.**

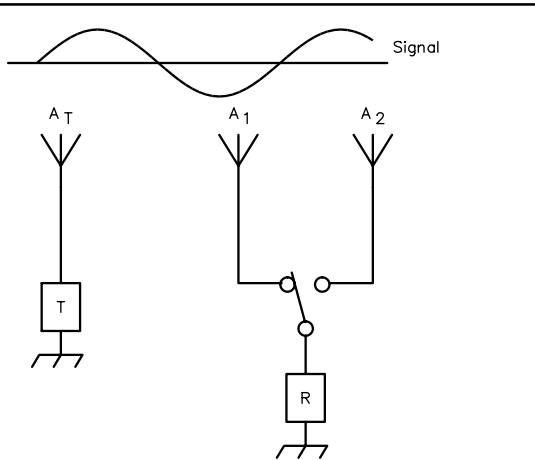
## Tuning

The dimensions given throughout this section are those for approximately 146 MHz. If the signal you will be hunting is above that frequency, then the measurements should be a bit shorter. If you wish to operate below that frequency, then they will need to be somewhat longer. Once you have built the antenna to the rough size, the fun begins. You will need a signal source near the frequency that you will be using for your RDF work. Adjust the length of the radiators and the spacing between them for the deepest null on your S meter. Make changes in increments of  $\frac{1}{4}$  inch or less. If you must adjust the phasing line, make sure that the  $\frac{1}{4}$ -wavelength section is exactly one-half the length of the half-wavelength section. Keep tuning until you have a satisfactorily deep null on your S meter.

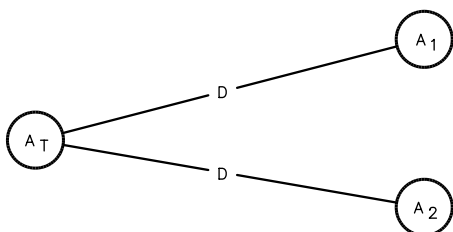
## THE DOUBLE-DUCKY DIRECTION FINDER

For direction finding, most amateurs use antennas having pronounced directional effects, either a null or a peak in signal strength. FM receivers are designed to eliminate the effects of amplitude variations, and so they are difficult to use for direction finding without looking at an S meter. Most modern HT transceivers do not have S meters.

This classic “Double-Ducky” direction finder (DDDF) was designed by [David Geiser, WA2ANU](#), and was described in *QST* for July 1981. It works on the principle of switching between two nondirectional antennas, as shown in **Fig 30**. This creates phase modulation on the incoming signal that is heard easily on the FM receiver. When the two antennas are exactly the same distance (phase) from the transmitter, as in



**Fig 30**—At the left,  $A_T$  represents the antenna of the hidden transmitter, T. At the right, rapid switching between antennas  $A_1$  and  $A_2$  at the receiver samples the phase at each antenna, creating a pseudo-Doppler effect. An FM detector detects this as phase modulation.



**Fig 31**—If both receiving antennas are an equal distance (D) from the transmitting antenna, there will be no difference in the phase angles of the signals in the receiving antennas. Therefore, the detector will not detect any phase modulation, and the audio tone will disappear from the output of the detector.

**Fig 31**, the tone disappears. (This technique is also known in the RDF literature as *Time-Difference-of-Arrival*, or TDOA, since signals arrive at each antenna at slightly different times, and hence at slightly different phases, from any direction except on a line perpendicular to and halfway in-between the two antennas. Another general term for this kind of two-antenna RDF technique is *interferometer*. —Ed.)

In theory the antennas may be very close to each other, but in practice the amount of phase modulation increases directly with the spacing, up to spacings of a half wavelength. While a half-wavelength separation on 2 meters (40 inches) is pretty large for a mobile array, a quarter wavelength gives entirely satisfactory results, and even an eighth wavelength (10 inches) is acceptable.

Think in terms of two antenna elements with fixed spacing. Mount them on a ground plane and rotate that ground plane. The ground plane held above the hiker's head

or car roof reduces the needed height of the array and the directional-distorting effects of the searcher's body or other conducting objects.

The DDDF is bidirectional and, as described, its tone null points both toward and away from the signal origin. An L-shaped search path would be needed to resolve the ambiguity. Use the techniques of triangulation described earlier in this chapter.

### Specific Design

It is not possible to find a long-life mechanical switch operable at a fairly high audio rate, such as 1000 Hz. Yet we want an audible tone, and the 400- to 1000-Hz range is perhaps most suitable considering audio amplifiers and average hearing. Also, if we wish to use the transmit function of a transceiver, we need a switch that will carry perhaps 10 W without much problem.

A solid-state switch, the PIN diode is used. The intrinsic region of this type of diode is ordinarily bare of current carriers and, with a bit of reverse bias, looks like a low-capacitance open space. A bit of forward bias (20 to 50 mA) will load the intrinsic region with current carriers that are happy to dance back and forth at a 148-MHz rate, looking like a resistance of an ohm or so. In a 10-W circuit, the diodes do not dissipate enough power to damage them.

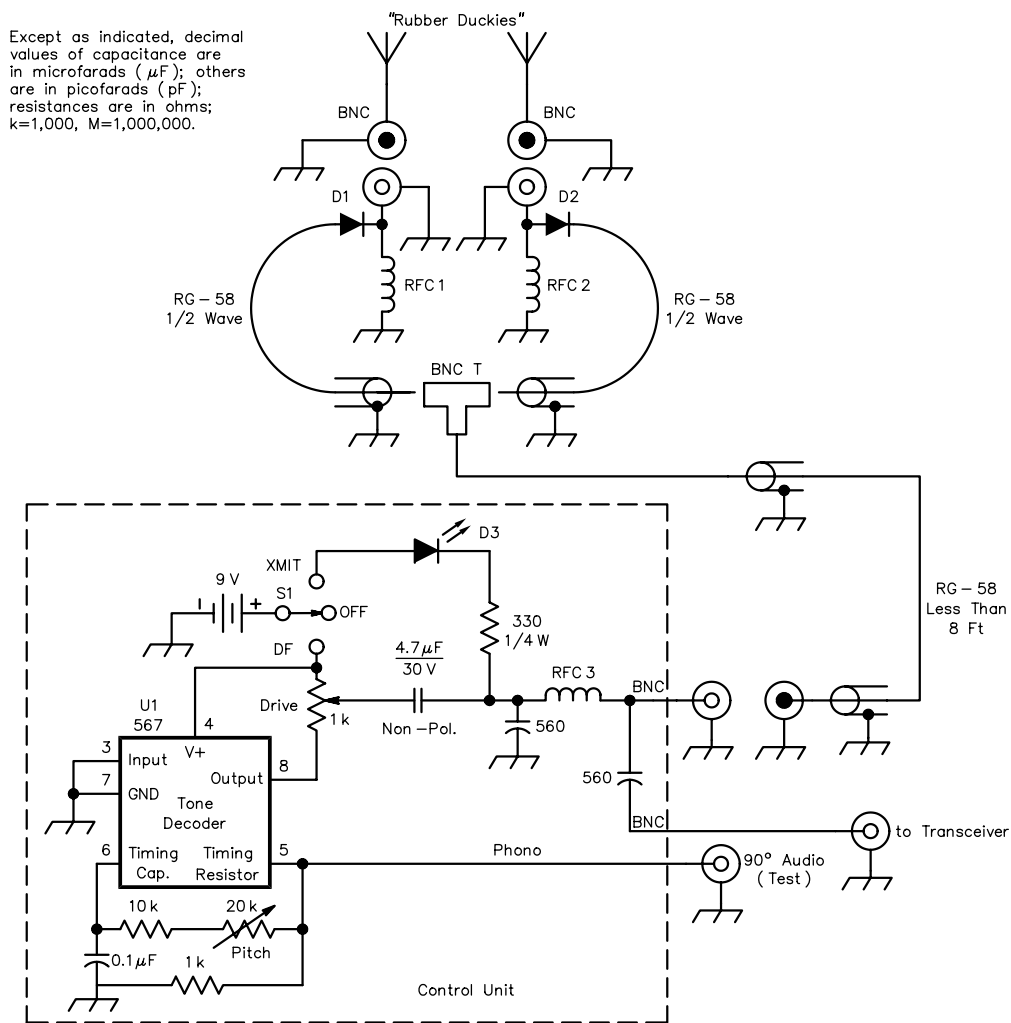
Because only two antennas are used, the obvious approach is to connect one diode *forward* to one antenna, to connect the other *reverse* to the second antenna and to drive the pair with square-wave audio-frequency ac. **Fig 32** shows the necessary circuitry. RF chokes (Ohmite Z144, J. W. Miller RFC-144 or similar vhf units) are used to let the audio through to bias the diodes while blocking RF. Of course, the reverse bias on one diode is only equal to the forward bias on the other, but in practice this seems sufficient.

A number of PIN diodes were tried in the particular setup built. These were the Hewlett-Packard HP5082-3077, the Alpha LE-5407-4, the KSW KS-3542 and the Microwave Associates M/A-COM 47120. All worked well, but the HP diodes were used because they provided a slightly lower SWR (about 3:1).

A type 567 IC is used as the square-wave generator. The output does have a dc bias that is removed with a nonpolarized coupling capacitor. This minor inconvenience is more than rewarded by the ability of the IC to work well with between 7 and 15 volts (a nominal 9-V minimum is recommended).

The nonpolarized capacitor is also used for dc blocking when the function switch is set to XMIT. D3, a light-emitting diode (LED), is wired in series with the transmit bias to indicate selection of the XMIT mode. In that mode there is a high battery current drain (20 mA or so). S1 should be a center-off locking type toggle switch. An ordinary center-off switch may be used, but beware. If the switch is left on XMIT you will soon have dead batteries.

Cables going from the antenna to the coaxial T connector were cut to an electrical  $\frac{1}{2}$  wavelength to help



**Fig 32—Schematic diagram of the DDDF circuit. Construction and layout are not critical. Components inside the broken lines should be housed inside a shielded enclosure. Most of the components are available from RadioShack, except D1, D2, the antennas and RFC1-RFC3. These components are discussed in the text. S1—See text.**

### DDDF Operation

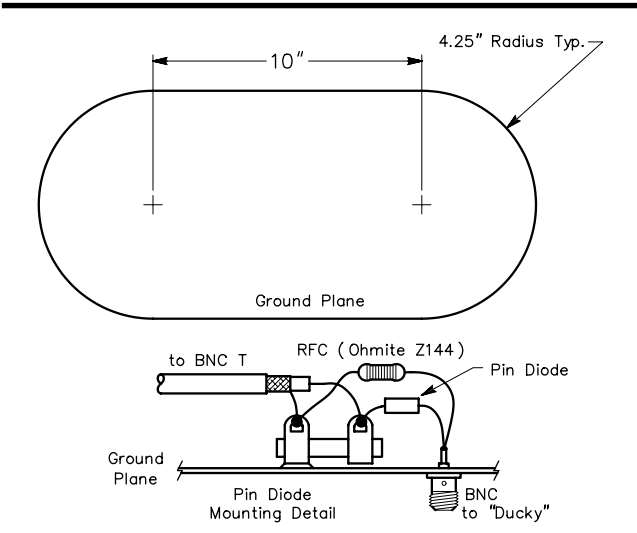
the open circuit, represented by the reverse-biased diode, look open at the coaxial T. (The length of the line within the T was included in the calculation.)

The length of the line from the T to the control unit is not particularly critical. If possible, keep the total of the cable length from the T to the control unit to the transceiver under 8 feet, because the capacitance of the cable does shunt the square-wave generator output.

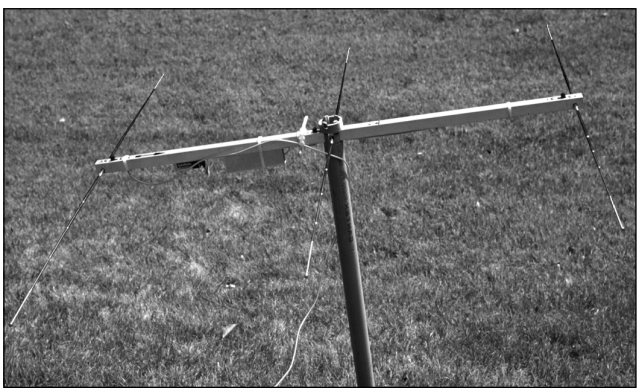
Ground-plane dimensions are not critical. See Fig 33. Slightly better results may be obtained with a larger ground plane than shown. Increasing the spacing between the pickup antennas will give the greatest improvement. Every doubling (up to a half wavelength maximum) will cut the width of the null in half. A  $1^\circ$  wide null can be obtained with 20-inch spacing.

Switch the control unit to DF and advance the drive potentiometer until a tone is heard on the desired signal. Do not advance the drive high enough to distort or “hash up” the voice. Rotate the antenna for a null in the fundamental tone. Note that a tone an octave higher may appear. The cause of the effect is shown in Fig 34. In Fig 34A, an oscilloscope synchronized to the “ $90^\circ$  audio” shows the receiver output with the antenna aimed to one side of the null (on a well-tuned receiver). Fig 34B shows the null condition and a twice-frequency (one octave higher) set of pips, while C shows the output with the antenna aimed to the other side of the null.

If the incoming signal is quite out of the receiver linear region (10 kHz or so off frequency), the off-null antenna aim may present a fairly symmetrical AF output to one side,



**Fig 33—Ground-plane layout and detail of parts at the antenna connectors.**



**Fig 34—Photo of Fox-Hunting DF Twin 'Tenna set up as a horizontally polarized, 3-element Yagi.**

**Fig 35A.** It may also show instability at a sharp null position, indicated by the broken line on the display in Fig 35B. Aimed to the other side of a null, it will give a greatly increased AF output, Fig 35C. This is caused by the different parts of the receiver FM detector curve used. The sudden tone change is the tip-off that the antenna null position is being passed.

The user should practice with the DDDF to become acquainted with how it behaves under known situations of signal direction, power and frequency. Even in difficult nulling situations where a lot of second-harmonic AF exists, rotating the antenna through the null position causes a very distinctive tone change. With the same frequencies and amplitudes present, the quality of the tone (timbre) changes. It is as if a note were first played by a violin, and then the same note played by a trumpet. (A good part of this is the change of phase of the fundamental and odd harmonics with respect to the even harmonics.) The listener can recognize

differences (passing through the null) that would give an electronic analyzer indigestion.

**A FOX-HUNTING DF TWIN 'TENNA**

Interferometers give sharp bearings, but they lack sensitivity for distant work. Yagis are sensitive, but they provide relatively broad bearings. This project yields an antenna that blends both on a single boom to cover both ends of the hunt. This is a condensation of a October 1998 *QST* article by R. F. Gillette, W9PE.

A good fox-hunting antenna must meet a number of criteria: (1) small size, (2) gain to detect weak signals and (3) high directivity to pinpoint the fox. Small antennas, however, do not normally yield both gain and directivity. By combining two antennas, all three requirements are satisfied in a way that makes a nice build-it-yourself project.

This antenna uses slide switches to configure it as either a Yagi or a single-channel interferometer. When used as an interferometer, a GaAs RF microcircuit switches the FM receiver between two matched dipoles at an audio frequency. To make the antenna compact W9PE used hinged, telescopic whips as the elements; they collapse and fold parallel to the boom for storage.

**The Yagi**

The Yagi is a standard three-element design, based on  $0.2\lambda$  spacing between the director, the driven element and the reflector. It yields about 7 dBi gain and a front-to-back ratio of over 15 dB. Because a slide switch is used at the center of each element and the elements have small diameters, their resonant lengths are different from typical ones. **Table 1** shows the sizes used and **Fig 34** shows the Yagi.

To make sure that radiation from the coax does not affect the pattern, the author used some ferrite beads as coaxial choke-baluns. This also prevents objects near the coax from affecting signal-strength readings. The Yagi also has a low SWR; with uncalibrated equipment, he measured less than 1.3:1 over most of the 2-meter band.

This Yagi has a lot more gain than a “rubber ducky,” but we need more directivity for fox hunting. That’s where the interferometer comes in.

**An Interferometer**

To form the interferometer, the two end elements are converted to dipoles and the center element is disabled. When the three switches in **Fig 35** are thrown to the right, the feed line to the receiver is switched from the center element to the RF switch output, and the end elements are connected via feed lines to the RF switch inputs. With the Yagi’s feed point open and the driven element equidistant from both interferometer antennas, the center element should have no effect on the interferometer. Nonetheless, it’s easier to collapse the driven-element whips and get them out of the way than to worry about spacing.

Now if both interferometer coax cables are of equal length (between the antennas and switch) and the two



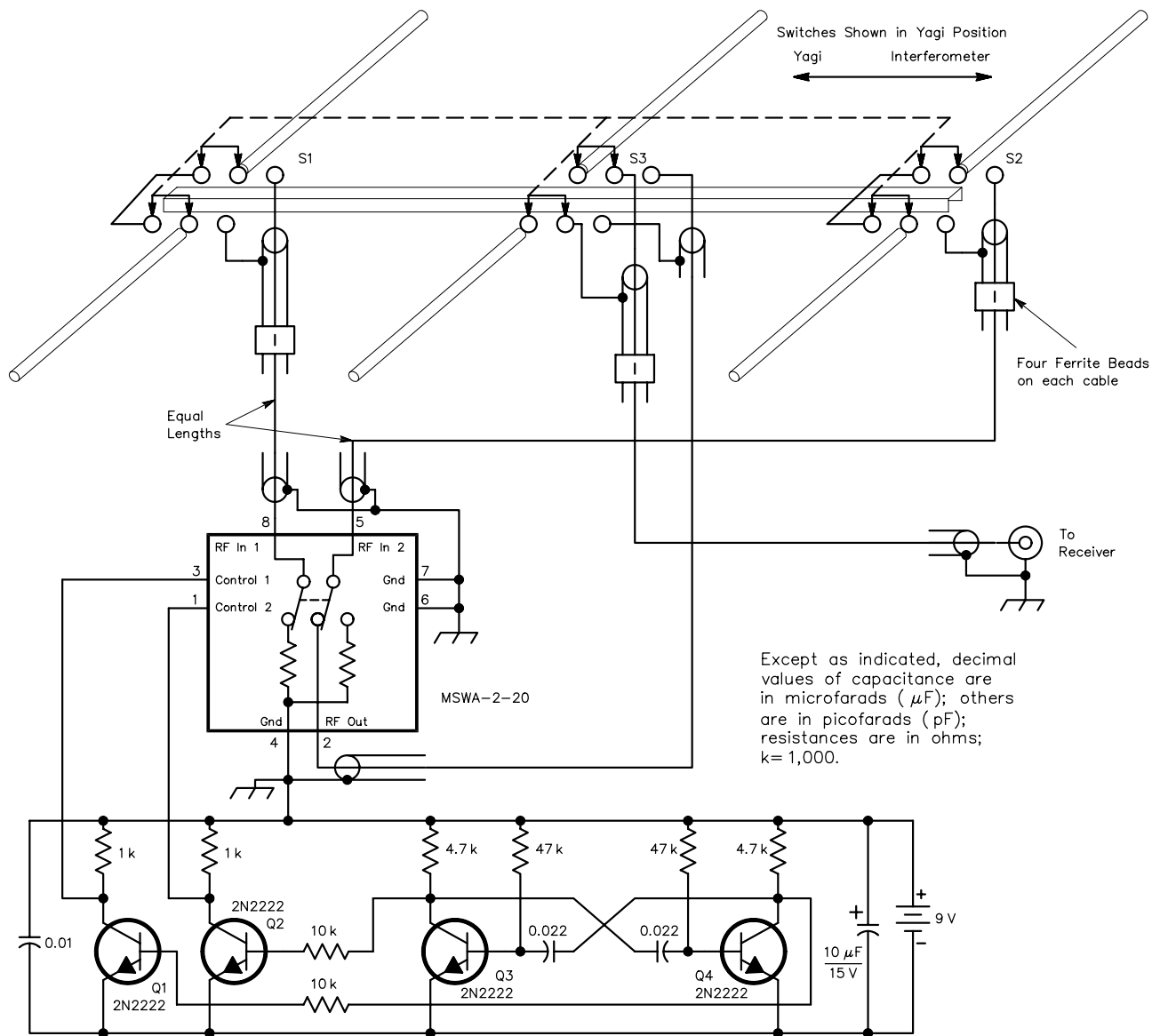


Fig 35—Schematic of the Yagi/interferometer antenna system.

Table 1  
Yagi Design

Item	Overall Length (Inches)	Boom to Element Tip (Inches)
Director length	34.75	17.00
Director to Driven El. spacing	15.75	16.00
Driven El. length	37.75	18.50
Driven El. to Reflector spacing	15.75	16.00
Reflector length	40.75	20.00

\*SWR less than 1.3:1 from 144.5 to 148 MHz

antennas are the same distance from the transmitter (broadside to it), the signals from both antennas will be in phase. Switching from one antenna to the other will have no effect on the received signal. If one antenna is a little closer to the transmitter than the other, however, there will be a phase shift when we switch antennas.

When the antenna switch is at an audio rate, say 700 Hz, the repeated phase shifts result in a set of 700 Hz sidebands. At this point, all that was needed was a circuit to switch from one antenna to the other at an audio rate. W9PE chose a low-cost Mini-Circuits MSWA-2-20 GaAs RF switch driven by a simple multivibrator and buffer. The GaAs switch is rated to 2.0 GHz, hence this switching concept can easily be scaled to other ham bands. The PC board should

work through the 440 MHz ham band. The author suggests adding a ground plane under the RF portion of the PC board and testing it before using it at a higher frequency.

The RF switch is controlled by a set of equal-amplitude, opposite-phase square waves: 0 V at one control port and -8 to -12 V at the other. (Mini Circuits is unclear about maximum voltages for this device. For safety, don't power it with more than 9 V.—*Ed.*) The opposite controls the other switch position. A 9-V battery was used as the power supply, with the positive terminal grounded. This results in a 0 V control signal to the RF switch when the buffer transistor is off and a  $V_{sat}$  (about 0.2 V less than the -9 V battery: -8.8 V) signal when the buffer transistor is saturated. The multi-vibrator has two outputs, and each drives a buffer resulting in the required equal-and-opposite-phase drive signals.

### Circuit Construction

After he selected the Mini-Circuits RF switch, W9PE realized that its small size would be best handled with a simple PC board. He made the prototype boards with a photocopy transparency technique.

A power on-off switch was not used, as the 9-V battery connector serves the same function. The battery fits tightly in the  $\frac{3}{4}$ -inch U channel. W9PE covered the circuit board with a plastic-lined aluminum cover, but plastic film and some aluminum foil, provide the same function. A cable tie will strap either into the U channel.

**Table 2** is a complete bill of materials. You can use any telescoping elements, providing that they extend to over 20 inches and have a mounting stud long enough to accommodate the insulated washers. As an alternate to the stud, they can have ends tapped to receive a screw for the insulated mounting. The author picked up his elements at a hamfest from the vendor listed; they are also available from most electronic parts houses. The Mini-Circuit RF switch is a currently available part.

### Antenna Construction

**Fig 35** shows the antenna schematic. It shows all three switches in the Yagi position; each would slide to the right for interferometer use. Slide switches work pretty well at 2 meters. Each of the elements is mounted to the boom with insulating washers, and a strip of copper stock connects each element to its slide switch. (You can substitute copper braid, solder wick, coax shield or any short, low resistance, low inductance conductor for the copper stock.) This switching arrangement allows you to switch the reflector and director from being parasitic elements (electrically continuous) to being dipoles (center fed).

Because the elements telescope, you can adjust the interferometer dipoles to exactly equal lengths each time you switch the antenna configuration from Yagi to interferometer. Again, choke baluns block RF on the outside of each element's coax.

Caution: Do not transmit when the RF switch is

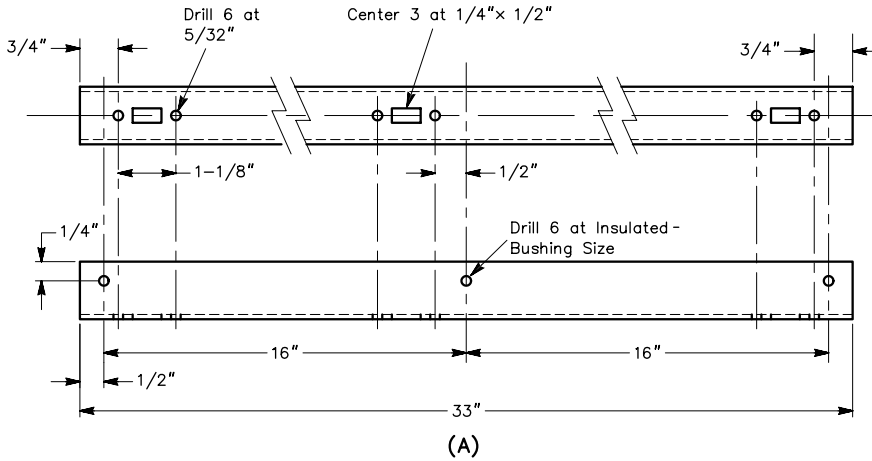
**Table 2**  
**Bill of Materials**

Quantity	Item
3 ft	$\frac{3}{4}$ -inch aluminum U channel
6 sets	insulated shoulder washers for elements
1	9 V battery
1	9 V battery connector
1	10 $\mu$ F, 16 V electrolytic capacitor
1	0.01 $\mu$ F, 25 V capacitor
2	0.022 $\mu$ F, 25 V capacitor
2	1 k $\Omega$ $\frac{1}{8}$ W resistor
2	4.7 k $\Omega$ $\frac{1}{8}$ W resistor
2	10 k $\Omega$ $\frac{1}{8}$ W resistor
2	47 k $\Omega$ $\frac{1}{8}$ W resistor
2	1 k $\Omega$ $\frac{1}{8}$ W resistor
4	2N2222 transistors
1	Mini-Circuits MSWA-2-20 (Mini-Circuits Labs, 13 Neptune Ave, Brooklyn, NY 11235; tel 718-934-4500, 417-335-5935, fax 718-332-4661; e-mail <a href="mailto:sales@minicircuits.com">sales@minicircuits.com</a> ; URL <a href="http://www.minicircuits.com">www.minicircuits.com</a> )
3	DPDT slide switch ( $\frac{1}{8}$ -inch, 29 mm, mounting centers), Stackpole, 3 A, 125 V used
10 ft	50 $\Omega$ coax (0.140-inch maximum OD)
1	coaxial connector (receiver dependent)
1	lot, mounting hardware
1	lot, heat-shrink tubing or equal
4	cable ties
1	2 $\times$ 3.5-inch single-sided fiberglass PC board
1	1-inch PVC conduit
12	#FB-20 ferrite beads 0.14-inch ID, 0.5-inch long (All Electronics Corp: PO Box 567, Van Nuys, CA 91408-0567; tel 888-826-5432, fax 818-781-2653, e-mail: <a href="mailto:allcorp@allcorp.com">allcorp@allcorp.com</a> ; URL <a href="http://www.allcorp.com/">http://www.allcorp.com/</a> )
6	20 $\frac{1}{2}$ -inch telescoping antenna elements (Nebraska Surplus, tel 402-346-4750; e-mail <a href="mailto:grinnell@probe.net">grinnell@probe.net</a> )
1	Special resist film (Techniks Inc, PO Box 463, Ringoos, NJ 08551; tel 908-788-8249, fax 908-788-8837; e-mail <a href="mailto:techniks@idt.net">techniks@idt.net</a> ; URL <a href="http://www.techniks.com/">http://www.techniks.com/</a> )

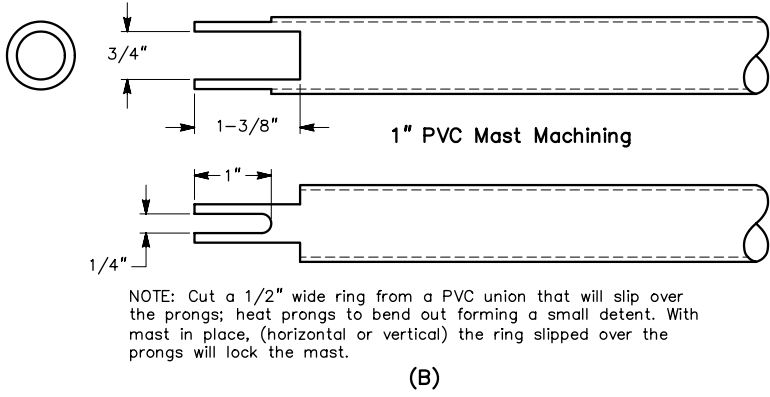
selected. Transmit only when in the Yagi configuration. RF power will destroy the Mini-Circuits RF switch. To be safe, lock out your transmit function. Most HTs have this capability. When using a mobile radio, disconnect the microphone. It is, however, safe to transmit in the Yagi configuration—which is nice for portable operating.

**Fig 36** gives dimensions for drilling a standard  $\frac{3}{4}$ -inch aluminum U channel for the boom and shows how the author cut a 1-inch PVC pipe (plastic conduit) for a mast and a mast locking ring. If PVC conduit is not available in your area, PVC water pipe (and a PVC union for the locking ring) will work. This mast allows mounting the antenna for either

### 3/4" Aluminum U Boom Drilling



**Fig 36—Boom-drilling and mast-machining details.**



vertical or horizontal polarization.

Be sure to test the plastic pipe you use for low RF loss. Do this by heating a sample in a microwave oven. Place a pipe sample and a glass of water in the oven. (The sample is not placed in the glass of water; the water keeps the microwave from operating without a load.) Bring the water to a boil, and then carefully check the sample's temperature. If the sample is not hot, its RF loss is low, and the plastic can be used.

#### Using the Antenna

When starting a hunt, set up the Yagi antenna by placing all switches in the Yagi position. Swing all of the telescoping elements perpendicular to the boom and set the whip lengths to achieve the proper element lengths, while keeping each element symmetrical about the boom. The cables or boom can be marked with the length data.

While the signal is weak, use the Yagi. It has 7 dBi gain, but its bearing resolution is only about 20°. When the signal gets stronger, use the interferometer. It has less gain, but its bearing resolution is better than 1°. If the fox transmitter begins overloading your receiver, collapse the whips

(equally) to reduce the gain and continue triangulating. Near the transmitter, you should triangulate both horizontally (azimuth) and vertically (elevation). The antenna works both ways, and the transmitter may be located above or below you.

#### Antenna Alternative

As an alternative to the telescoping elements, George Holada, K9GLJ, suggested using fixed-length elements with banana plugs matched to banana jacks on the boom. Three pairs would be used for the Yagi, an extra driven-element pair for the interferometer mode and two short-element pairs to reduce the received signal level if an overload condition occurs. He also suggested a PVC boom allowing the elements to be stored inside the boom.

#### THE FOUR-WAY MOBILE DF SYSTEM

This innovative, yet simple, RDF antenna system was described in an article by [Malcolm C. Mallette, WA9BVS](#), in November 1995 *QST*. It is derived from the TDOA design shown earlier in this chapter by David T. Geiser, WA2ANU, and by a design by Paul Bohrer, W9DUU. (See

Bibliography.)

Direction-finding often involves two different activities: DFing on foot and DFing from a vehicle. Often, you must track the signal using a vehicle, then finish the hunt on foot. Whether on foot or in a vehicle, the primary problem you'll encounter when trying to locate the transmitter is multipath reception. Multipath reception involves receiving the same signal by more than one path, one signal from the true direction of the transmitter and others by reflected paths that may come from widely different directions. VHF and UHF signals bounce off almost any object and hide the true source of a signal. For example, if there's a large metal building north of you, a signal from the south may arrive from the north because the signal bounces off the building and back to you.

Multipath reception effects can be defeated by taking a number of readings from different positions and arriving at an average direction. While moving at road speeds in a vehicle, it's possible to take a number of readings from different positions and average them, and it's also possible to average a number of readings over a distance of travel by electronic means. The true bearing to the transmitter can usually be found by either method.

DFing equipment for use on foot is simpler than systems for use on a vehicle. While afoot, you can turn at will or easily rotate an antenna. Turning a vehicle while going down a street may result in a fender-bender if you're not careful!

The simplest DFing system to use while on foot consists of an S-meter-equipped hand-held receiver and a small, hand-held Yagi with an attenuator in line between the antenna and receiver. The attenuator keeps the S meter from pinning. The direction in which the beam points when the strongest signal is received is the direction of the transmitter. Of course, you'll want to take readings at several locations at least a wavelength apart to obtain an average heading, as multipath reception can still cause false readings in some locations.

Another approach that many hams have taken is the simple WA2ANU DDFB—it is now commonly known simply as the "buzzbox." Various commercial versions of the hand-held buzzbox system are available. Some systems have been upgraded to indicate whether the signal is arriving from the left or right of your position. The main drawback, however, to the buzzbox is that it's not as sensitive as a simple dipole and not nearly as sensitive as a beam.

In theory, you could take a buzzbox or Yagi/attenuator system in a car, stop periodically, get out and check the direction to the transmitter, then climb back in and drive off. Although this procedure works, it isn't very practical—it takes a long time to find the transmitter.

This design is for a left-right, front-back box (LRFB box) that indicates whether the received signal is to the left or right and whether it is to the front or back of the receiver. The location display consists of four LEDs arranged in a diamond pattern (see the title-page photo). When the top LED is on, the signal is coming from the front. When the

top and right LEDs are on, the transmitter is between the front and the right. When only the right LED is on, the signal is directly to the right. When the bottom LED and right LED are on, the transmitter is to the right and to the back. The same pattern occurs around the clock. Therefore, four LEDs indicate eight directions. As most highways and streets have intersections that force a driver to choose moving straight ahead, right or left, the indication is sufficiently precise for practical transmitter hunting.

If the four-LED display is used alone, all parts can be obtained from your local Radio Shack store. Two zero-center 50- $\mu$ A meters (50-0-50)—M1 and M2—can be used in addition to, or in place of, the LEDs, but RadioShack does not stock such meters. **Fig 37** shows the front panel layout of the LRFB.

The LRFB box uses four mag-mount  $1/4$ - $\lambda$  antennas placed on the vehicle roof as shown in **Fig 38**. The whips in the mag mounts can be changed to  $1/4$ - $\lambda$  440-MHz whips and the antennas placed closer together when switching from 144-MHz to 440-MHz operation.

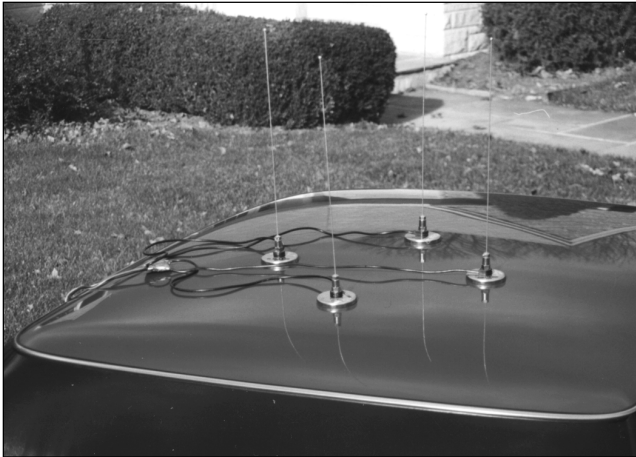
### Circuit Description

See **Fig 39** in the following discussion (pages 26 and 27). U2, a 555 timer, generates a string of square-wave pulses at pin 3. The pulse frequency is determined by the setting of R4. The pulses are fed to the clock input (pin 14) of U3, a 4017 decade counter. On the first pulse, a positive voltage appears at U3, pin 3. On receipt of the second pulse from U2, pin 3 of U3 goes to ground and a positive voltage appears on pin 2. This sequence continues on successive pulses from U2 as pins 3, 2, 4, 7, 10, 1, 5, 6, 9 and 11 go positive in succession.

D1 through D5, and D6 through D10, OR the pulses.



**Fig 37**—Front panel of the Four-Way DFER. At the extreme left of the front panel is the VOLUME control. Immediately to the right is the RCV/OFF/DF center-off toggle switch, with the damping (DMP) control switch nearby. Four LEDs mounted in a diamond pattern indicate signal direction: front (yellow), right (green), back (orange) and left (red). The horizontally mounted zero-center meter indicates left/right signal reception, the vertically mounted meter displays front/back signal reception. A small speaker is mounted on the top cover.



**Fig 38—Placement of the four antennas on the author's car roof. The small object to the left of the antennas is the switch board.**

The result is that TP3 goes positive on the first pulse from U2, while TP2 is at 0 V. The next pulse of U2 results in TP2 going positive and TP3 going to 0 V. This sequence repeats as the counter goes around to make pin 3 positive again, and recycles.

### Antenna Switching

U2 and U3 produce alternating pulses at TP2 and TP3. If we wanted only to alternately turn on and off two antennas, we could use the pulses at TP2 and TP3. The design ensures that the pulses at TP2 are the same length as the pulses at TP3. For the LRFB box, however, we need to switch between the left-right antennas many times, then switch between the front-back antennas many times.

Pin 12 of U3, CARRY OUT, emits a pulse every time U3 counts through its cycle of 10 pulses. The carry pulses from U3 go to U4, pin 14, the clock input of that 4017 counter. As U4 cycles, its output pins pulse; those pulses are, in effect, directed by D11 through D20.

As a result, TP4 is positive during the first 50 pulses from U2 and TP5 is positive during the second 50 pulses of U2. Q1 through Q6 form a quad AND gate. They AND the pulses at TP4 and TP5 with the alternating pulses at TP2 and TP3 so that the result is a pulse at the base of Q9, followed by a pulse at the base of Q10, a pulse at the base of Q9, and so on. The pulses alternate 25 times between Q9 and Q10. Then, as TP4 goes to 0 V, TP5 rises from 0 V to some positive voltage and the alternating pulses appear at the bases of Q7 and Q8. The pulses alternately go to the bases of Q7 and Q8 25 times. Then they alternate between the bases of Q9 and Q10 25 times. This pattern continues as long as the unit is in DF operation.

In Fig 40, two leads of a four-conductor-plus-ground cable to the antenna-switch board are connected to points A and B. The same pulses that turn Q7 and Q8 off and on turn on and off the left and right antennas. One of those two

antennas is turned on and off in phase with Q7 and the other is turned on and off in phase with Q8. The PHASE switch, S3, determines which antenna is in phase with which transistor. Similarly, the two front/back antennas are turned on and off in phase with Q9 and Q10, and S4 determines which antenna is in phase with which transistor.

The pulses arriving at points A and B turn on and off the diodes connecting the coax of the left and right antennas to the receiver coax. This occurs 25 times, thereby switching the receiver between the left and right antennas 25 times. Similar switching then occurs between the front and the back antennas from pulses arriving at points C and D.

### Detector Circuit

The detector circuit (back again in Fig 39) starts with U5, a 741 op amp that amplifies the receiver's audio output. The audio is fed into R24 and R27, two 4.7-k $\Omega$  pots. The zero-center, 50- $\mu$ A meters across R24 and R27 are optional. The meters, as well as the LEDs, indicate front/back and left/right. Such meters can be expensive unless you find surplus meters, and they're not really necessary.

When the left/right antennas are active, one end of R24 is grounded by Q7 and Q8 on each alternate pulse. If Q7 is conducting, Q8 is not conducting. On each pulse, one of the left/right antennas is turned on and one end of R24 is grounded. On the next pulse, the other left/right antenna is turned on and the other end of R24 is grounded. If there is a phase difference between the signal received by the left antenna and the signal received by the right antenna, a dc voltage is built up across R24. That voltage causes the quad comparator, U7 in Fig 41 to turn on DS3 (red) or DS4 (green) L/R LEDs. If the optional left/right meter is installed, it deflects to indicate the direction as do the LEDs.

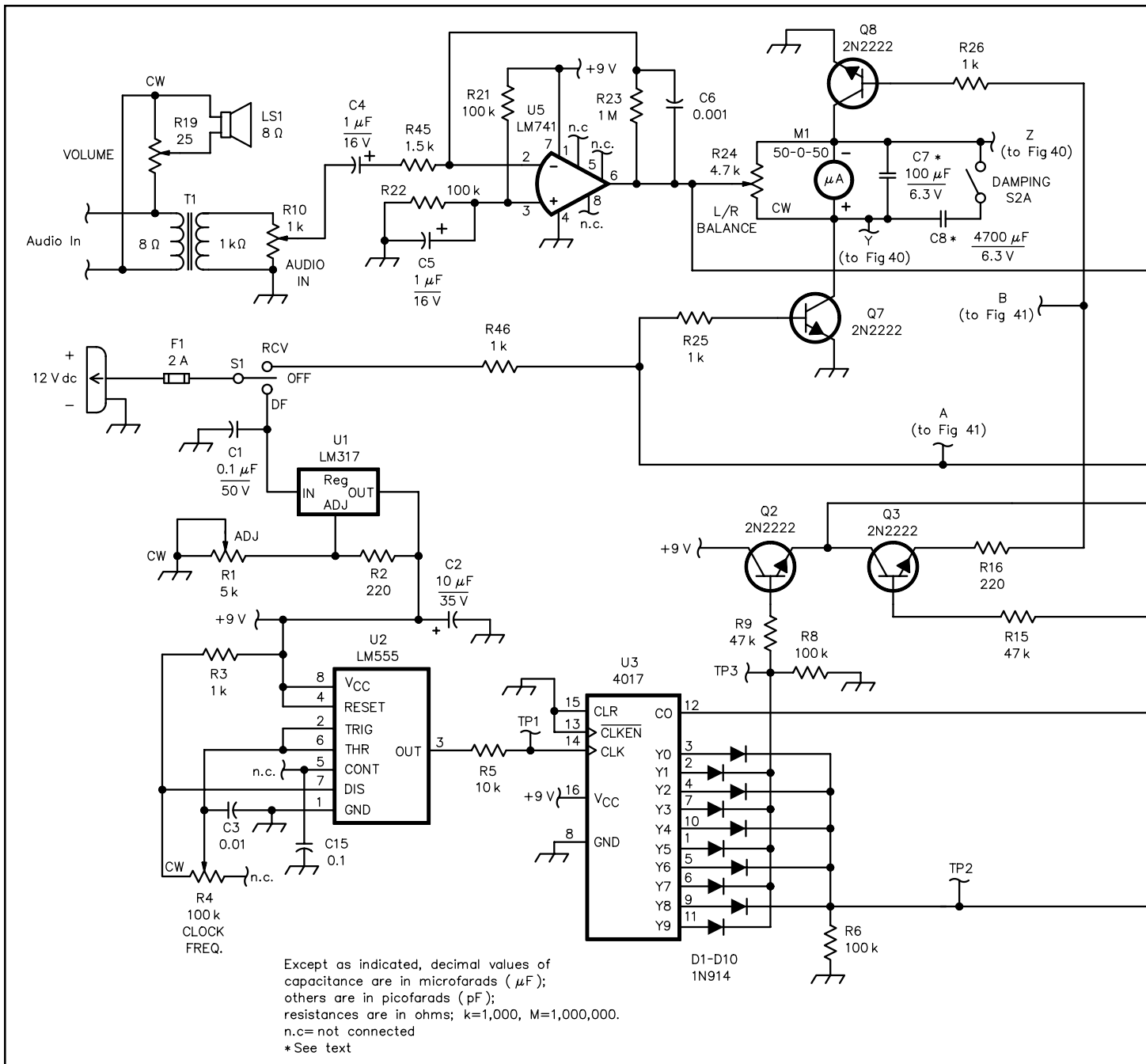
After 25 cycles, the left and right antennas are both turned off and the front and back antennas are cycled on and off 25 times with the same detection process, producing a voltage across R27 if there is a phase difference between the RF received by the front and the back antennas. That voltage across R27 causes quad comparator U6 to turn on DS1 or DS2.

C9 and C10, for the F/B detector, and C7 and C8, for the L/R detector, damp the voltage swings caused by multipath reception. To control damping, S2A and S2B switch the 4700- $\mu$ F capacitors in or out of the circuit. You want the greatest amount of damping when you drive through an area with a lot of multipath propagation (as from buildings); a lot of damping helps under those circumstances.

### Construction

The prototype was built using a pad-per-hole Radio Shack board. However, a PC board makes construction a lot faster. Far Circuits offers a printed-circuit project on their Web site: <http://www.cl.ais.net/farcir/>. Except for the optional meters and the nonpolarized capacitors, most parts are available from Radio Shack.

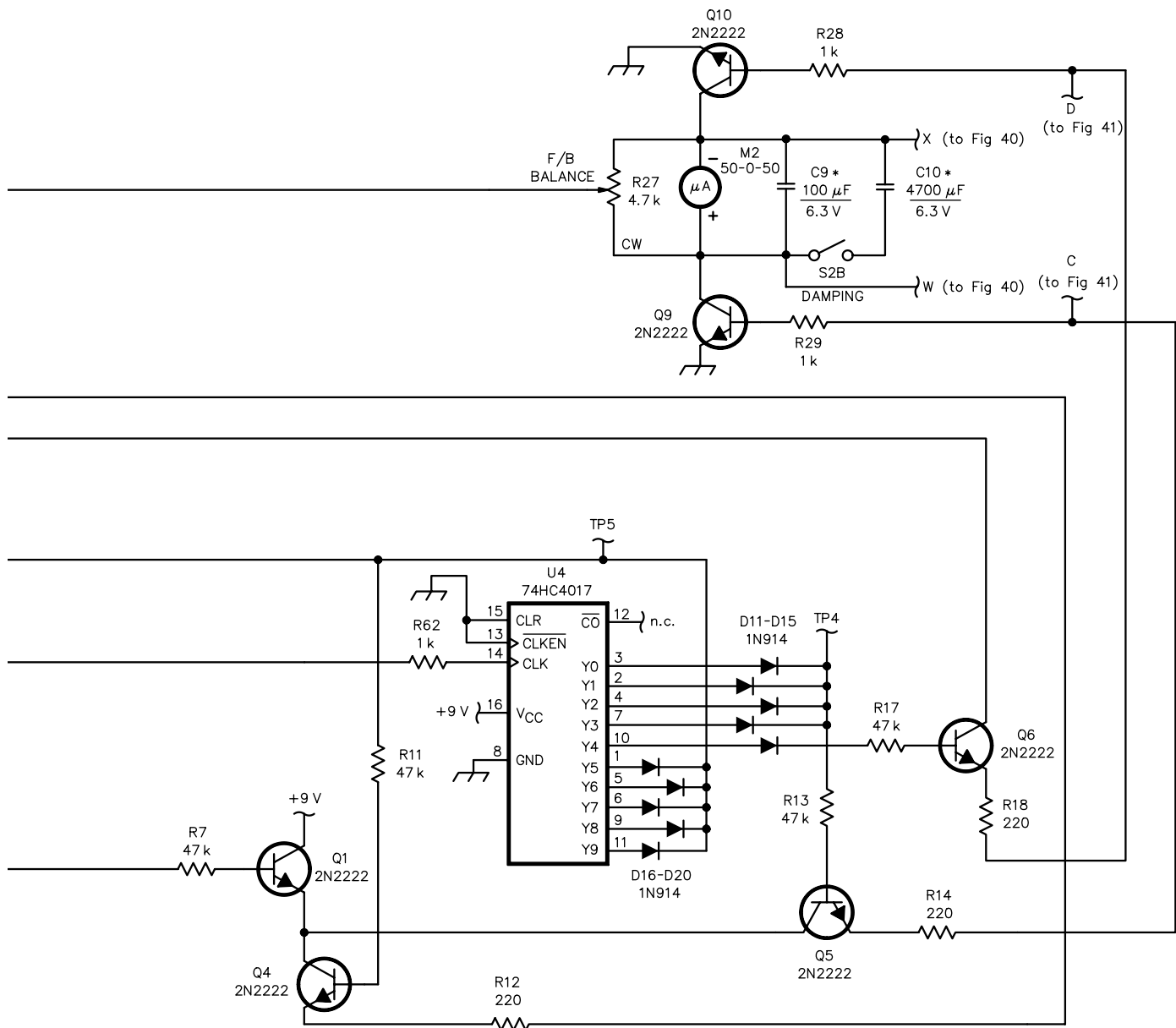
First build the power supply so you can power the unit



**Fig 39**—Unless otherwise specified, part numbers in parentheses are RadioShack. All fixed-value resistors are  $\frac{1}{4}$ -W, 5%-tolerance units. Equivalent parts can be substituted.

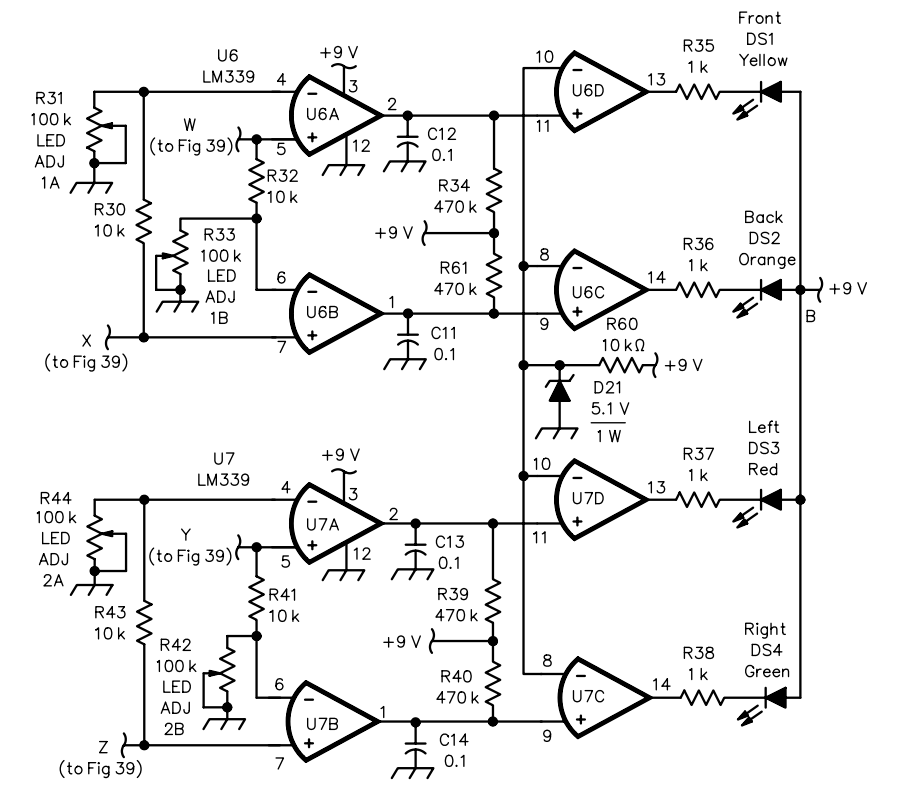
- C1, C15**—0.1- $\mu\text{F}$ , 50-V (272-1069)
- C2**—10- $\mu\text{F}$ , 35-V electrolytic capacitor (272-1025)
- C3**—0.01- $\mu\text{F}$ , 25-V disc-ceramic capacitor (272-131)
- C4, C5**—1- $\mu\text{F}$ , 16-V electrolytic capacitor (272-1434)
- C6**—0.001- $\mu\text{F}$ , 25-V disc-ceramic capacitor (272-126)
- C7, C9**—100- $\mu\text{F}$ , 6.3-V bipolar (nonpolarized) capacitor; Digi-Key P-1102, available from Digi-Key Corp, 701 Brooks Ave S, PO Box 677, Thief River Falls, MN 56701-0677, tel 800-344-4539, 218-681-6674; fax: 218-681-3880; RadioShack stocks 100- $\mu\text{F}$ , 35-V axial (272-1016) and radial-lead (272-1028) electrolytic capacitors.
- C8, C10**—4700- $\mu\text{F}$ , 6.3-V bipolar (made of five 1000- $\mu\text{F}$ , 6.3-V bipolar capacitors), Digi-Key P1106. Standard 1000- $\mu\text{F}$ , 35-V radial and axial-lead

- electrolytic capacitors are available from RadioShack; a 4700- $\mu\text{F}$ , 35-V axial-lead electrolytic capacitor is also available (272-1022). Note that C7, C8, C9 and C10 are non-polarized capacitors because a small reverse voltage can appear across the meter and capacitors when the system is in use. Standard polarized electrolytics have been used in a number of units using this circuit (the same detector circuit used in W9DUU's unit) without any known ill effects, however.
- D1-D20**—1N914 silicon switching diode (276-1620 or 276-1122)
- F1**—2-A fuse (270-1007)
- LS1**—8-W speaker (40-245)
- M1, M2**—Zero-center, 50- $\mu\text{A}$  meter; optional—see text



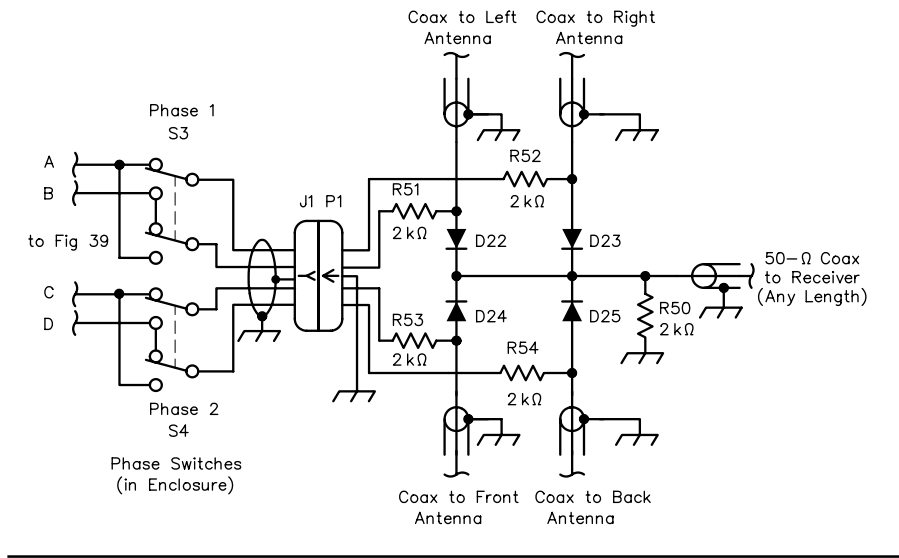
**Q1-Q10**—MPS2222 or 2N2222 NPN silicon general-purpose transistors (276-2009)  
**R1, R24, R27**—4.7 k $\Omega$  (271-281); note: many of the fixed-value resistors can be found in RadioShack resistor assortment packages 271-308 and 271-312.  
**R2, R12, R14, R16, R18**—220  $\Omega$  (271-1330)  
**R3, R25, R26, R28, R29**—1 k $\Omega$  (271-1321)  
**R4**—100-k $\Omega$  trimmer potentiometer (271-284)  
**R5**—10 k $\Omega$  (271-1335)  
**R6, R8, R21, R22**—100 k $\Omega$  (271-1347)  
**R7, R9, R11, R13, R15, R17**—47 k $\Omega$  (271-1342)  
**R10**—1-k $\Omega$  trimmer potentiometer (271-280)  
**R19**—25- $\Omega$  panel-mount potentiometer (271-265A)  
**R23**—1 M $\Omega$  (271-1134)

**R45**—1.5 k $\Omega$  (part of 271-312 assortment)  
**S1**—SPDT, center-off switch (275-325)  
**S2**—DPDT switch (275-626)  
**T1**—8- $\Omega$  to 1-k $\Omega$  audio-output transformer (273-1380)  
**U1**—LM317T, 1.5-A, three-terminal, adjustable voltage regulator (276-1778)  
**U2**—555 timer (276-1723)  
**U3, U4**—4017 decade counter (276-2417)  
**U5**—LM741 op amp (276-007)  
**Misc:** two 8-pin IC sockets (276-1995); two 16-pin IC sockets (276-1992); experimenter's PC board (276-148) or FAR Circuits PC board set; enclosure; four mag-mount antennas, four-conductor shielded cable; in-line fuse holder (270-1281).



**Fig 40—Schematic of the antenna switch board. Part numbers in parentheses are RadioShack. All fixed-value resistors are 1/4-W, 5%-tolerance units. Equivalent parts can be substituted.**

- D22-D25—1N914 silicon switching diode (276-1620 or 276-1122)**
- J1—Six-pin female Molex connector (274-236 or 274-155)**
- P1—Six-pin male Molex connector (274-226 or 274-152)**
- R50-R54—2.2 kΩ (can be found in RadioShack resistor assortment packages 271-308 and 271-312); also available in pack of five (271-1325)**
- S3, S4—DPDT switch (275-626)**



**Fig 41—Schematic of the LED driver circuit. Part numbers in parentheses are RadioShack. All fixed-value resistors are 1/4-W, 5%-tolerance units. Equivalent parts can be substituted.**

- C11-C14—0.1-μF, 25-V disc-ceramic capacitor (272-135)**
- D21—1N4733, 5.1-V, 1-W Zener diode (276-565)**
- DS1-DS4—LEDs; one each red (276-066); green (276-022); yellow (276-021); orange (276-012)**
- R30, R32, R41, R43—10 kΩ (271-1335)**
- R34, R39, R40, R61—470 kΩ (271-1354)**
- R35-R38—1 kΩ (271-1321)**
- R31, R33, R42, R44—100-kΩ trimmer potentiometer (271-284)**
- U6, U7—LM339 quad comparator (276-1712)**
- Misc: two 14-pin IC sockets (276-1999)**

from your car or another 12-V source. Apply 12 V to the DFer and adjust R1 until U1's output is +9 V. (You can use a 9-V battery and omit the power-supply section, but you'd better take along a spare battery when you go DFing.)

Install U2 and its associated parts. Power up and turn on S1. A string of pulses should appear at TP1. If you have a frequency counter, set R4 for a pulse frequency of

2200 Hz at TP1. If you don't have a counter, connect a 0.1-μF capacitor from TP1 to headphones or a small speaker and set R4 for a tone of about 2 kHz. Later, you'll adjust the clock so the unit works with the passband of your receiver.

Turn off S1 and remove the power source. Install U3 and its diodes. Pin 12 of U3 need not be connected yet. Apply power and turn on S1. At TP2 and TP3, you should find



alternating 1100-Hz pulses. If you have a dual-trace scope, you can see that the pulses alternate. If you have a single-trace scope, connect TP3 to TP2 and to the scope input and the trace will appear as a solid line as there is a pulse at either TP2 or TP3 at all times. If you don't have a scope, the tone in a speaker or earphones from TP2 or TP3 will sound half as high (about 1 kHz) as the tone at TP1.

Turn off S1. Install U4 and its diodes. Note that pin 12 of U3 is connected to pin 14 of U4. At TP4 and TP5, there should be long pulses—five times longer than the pulses at TP1, and the pulses should alternate between TP4 and TP5. The pulse frequency should be about 44 Hz. Power down and turn off S1. Install the remaining circuit components. When you power up, 25 alternating pulses should appear at A and B, then 25 alternating pulses should appear at C and D. Use a scope to verify that.

If you're not using the optional panel meters, connect a voltmeter across R24 (L/R BALANCE), using the lowest dc-voltage range. Note that neither end of R24 is grounded. With no audio input, adjust R24 until there is no voltage across it. Do the same with R27 (F/B BALANCE). If you use the optional meters, adjust R24 and R27 so there's no current shown on either meter.

Power down and assemble the rest of the circuit. With power applied, but with no audio input, adjust R31, 33, 42 and 44 so that the four LEDs (DS1 through DS4) are off. The objective of the following adjustments is to get the red and green LEDs to turn on with the same voltage amplitude, but opposite polarity, across R24. Move R24's wiper so a low positive voltage appears across R24, as indicated by the voltmeter connected across R24 or movement of the panel-meter needle. Adjust R44 (LED ADJ 1A) and R42 (LED ADJ 1B) so that the green LED (DS4) comes on when the voltage goes positive at one end of R24, but goes off when R24 is adjusted for 0 V across R24.

Next, adjust R24 for a slight negative-voltage indication and adjust R42 and R44 so that the red LED (DS3) comes on, but extinguishes when the voltage across R24 is 0 V. When you're done, adjusting R24's wiper slightly one way should illuminate the red LED. Both LEDs should be off when there's no voltage across R24; rotating R24's wiper slightly in the opposite direction should turn on the green LED.

Connect the voltmeter across R27 or use the panel meter as an indicator. With no audio input, adjust R27 so that there's no voltage across R27. Adjust R31 (F/B LED ADJ 1A) and R33 (F/B LED 1B) so that a F/B LED (DS1) is on when there is a slight positive voltage across R27 and the other F/B LED (DS2) is on when there is a negative voltage across R27.

### Switch Board

Assemble the switch board for the four mag-mount antennas (see Fig 40). You can use half of a RadioShack dual pad-per-hole PC board (RS 276-148) as a platform. Lead length is critical only on this board and in the length of the coax from the switching board to the antennas, so avoid wire-wrap construction here.

### Feed Lines

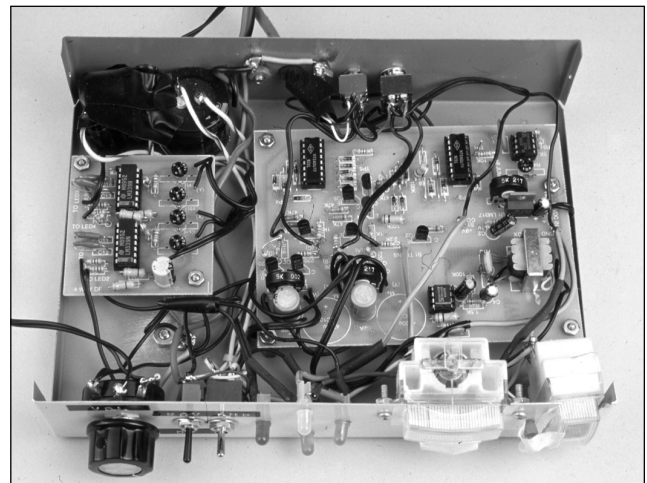
The coax lines from the switch board to each of the four antennas must be of equal length. The coax lengths should be long enough to permit each antenna to be placed slightly less than  $\frac{1}{4} \lambda$  from its counterpart, at the lowest frequency of operation. (There's a local belief that  $27\frac{1}{2}$  inches is the best length. The author used that length and it works, but other lengths might work as well.) An attempt to locate the switch board inside the vehicle and run equal-length 12-foot-long cables to the antennas failed. Keep the switch board on the vehicle's roof.

Use the same type of coax for all lines—that is, don't mix foam and polyethylene dielectric coax on the antenna lines. If the velocity factor of the lines is not equal, a phase shift in the signals will exist even when the transmitter is dead ahead and it will lead you astray.

Solder the coax from the antennas directly to the board—don't use connectors. From the switch board to the receiver, use 50- $\Omega$  coax of any type and length. Equip the receiver end of the line with a connector that mates with your receiver's antenna-input jack. Make the four-conductor shielded cable from the main DFER box to the switch board long enough to reach from the LRFB box's operating position to the roof of the car. Construct the antennas so that the whips can be changed easily for use on any frequency in which you're interested.

### Mechanical Assembly

Mount the finished PC boards in a metal box of your choice. You can follow the construction method used in the



**Fig 42—An inside view of one DF unit built into a  $2 \times 8 \times 5\frac{3}{4}$ -inch (HWD) box. Because of the height restriction, the two 4700- $\mu$ F damping capacitors (C8 and C10) are not mounted on the PC board, but near the rear panel behind the smaller of the two PC boards. One of the 4700- $\mu$ F damping capacitors is a standard electrolytic, the other is a parallel combination of five 1000- $\mu$ F, 6.3-V bipolar (nonpolarized) capacitors wrapped in electrical tape.**



**Fig 43—The rear panel of the DF unit supports the two DPDT PHASE toggle switches. Grommets in the panel holes allow abrasion-free passage of the antenna, dc-power and audio cables. The dc power cord is outfitted with an inline fuse holder and a male Jones plug. A six-pin female Molex connector (five pins are used) feeds the four antennas. The audio-input cable is terminated in a 1/8-inch diameter male plug.**

prototype (see [Fig 42](#) and [Fig 43](#)), but do ensure that R4 can be adjusted easily with a tuning tool from outside the box. A hole drilled in the box at the right point will suffice. Arrange the LEDs in a diamond pattern on the front panel, with the left LED (red) to the left, the right LED (green) on the right, and the front and back LEDs at the top and the bottom.

Wrap the switch board with tape to waterproof it, or place it in a watertight box. Arrange the mag-mount antennas on top of the vehicle in a diamond shape. The distance between each antenna pair should be less than  $\frac{1}{4} \lambda$  at the operating frequency. (In limiting the distance between antennas in a pair—F/B or L/R—to less than  $\frac{1}{4} \lambda$ , the author followed W9DUU's example.)

### Final Adjustments

It's best to start on 2 meters. Install the 2-meter whips in the antenna bases. Mount the antennas on the top of your vehicle. Identify the left and right antenna bases with L and R, and mark the front and back antenna bases, too.

A good way to find out if the antennas are properly installed is to short either the left or right antenna with a clip lead from the whip to the metal base; the L/R meter will deflect one way and the left or right LED will light. If you short one of the front and back antennas with a clip lead, the front or back LED will come on. If you short one of the L/R antennas and it makes the meter go to the right, it does not necessarily mean you have the PHASE switch in the proper position. That depends on the relative phase determined by the number of audio stages in your receiver, each of which may contribute a shift of  $180^\circ$ .

Connect the coax from the switch board to your FM receiver. It must be an FM receiver; an AM VHF or AM aircraft receiver won't suffice. Connect the audio output of

your 2-meter receiver to the LRFB box audio input. If you're using a transceiver, disable its transmit function by removing the mike. You don't want to transmit into the switch board!

Turn on the receiver and place the LRFB box in receive by setting S1 to the RCV position. Center R10. Only one of the antennas will be turned on and the DF operation will be disabled. Back off the squelch and notice that you hear the audio from the speaker of the LRFB box. Switch to an unused simplex channel. Have a friend with an HT stand 20 feet or so in front of the vehicle. With the receiver in the car turned off, turn S1 to DF. The four LEDs should be off. If an LED lights, adjust R24 and R27 for zero voltage. If the LED is still on, readjust R31 and R33, or R42 and R44 as explained earlier. When all four LEDs are off with the antennas connected, no audio from the receiver and no RF input signal, you're ready. Turn on your receiver and have your friend transmit on the 2-meter frequency (simplex) that your receiver is set to. When he transmits, one or more of the LEDs should illuminate. Ignore the front/back LEDs, but check to see if the right or left LED is on. If the right LED is on and your friend is standing to the right of the center of the vehicle front, all is well. Have him walk back and forth in front of the vehicle and notice that when he is to the right, the green LED turns on, and when he's to the left, the red LED glows. If the indications are reversed, that is, if the LRFB box indicates left when your friend is to your right, reverse the position of PHASE switch S3.

When the L/R indicators are working properly, have your friend walk back and forth between a position 20 feet to the front and right of the car and a position 20 feet away to the rear and right of the car. The right LED should stay on, but the front LED should be on when the HT is in front of the antennas, and the back LED should be on when the HT is behind the antennas. If the front/back indications are reversed, reverse the position of PHASE switch S4.

While receiving a signal from your friend's HT, adjust R4 for maximum deflection on any one of the two optional meters, or on a voltmeter (set on the lowest dc voltage range) connected across R24 or R27. Look for the maximum deflection of the meter needle as the meter swings both ways while the signal source moves from back to front or left to right (depending, of course, on which panel meter you're looking at or which resistor—R24 or R27—your voltmeter is across). The audio passband of FM receivers varies, and if you switch from an ICOM IC-27 to an ICOM IC-W2A, for example, you'll have to change U2's master clock frequency. You may encounter receivers that don't require readjusting R4, but such readjustment should be expected. When changing receivers, you may also need to change the position of PHASE switches S3 and S4. This may also be necessary when changing from UHF to VHF, or VHF to UHF on the same receiver, as the number of receiver stages (and, hence, the audio phase) may change from band to band.

### Audio Level Adjustments

With meter damping (S2) off, adjust R10 so that you

have full deflection of one of the two meters (or your multimeter) with the signal source at a 45° angle from the vehicle (halfway between ahead and right), and a reasonable audio level from the speaker. Turn the rig's volume control all the way up to ensure that the audio circuit doesn't overload. If it overloads, the meters won't deflect. From zero to full blast, the meter should deflect more and more (unless the signal is straight ahead or exactly left or right). If you're using an H-T, maximum deflection of the meter should occur before the volume control is 3/4 of maximum, or before the volume control is at 1/2 of maximum if you're using a mobile rig. If R10 is properly adjusted, turning the volume control to maximum won't cause the meter to fall back toward zero. If increasing the volume causes the meter to deflect less, then R10's setting is too high.

Now have your friend walk around the vehicle with the HT transmitting and notice that the LEDs indicate the signal direction. On 2 meters in a clear field, the indications should be correct 80 or 90% of the time. The erroneous readings that occasionally occur are due to multipath propagation caused by the irregular shape of the vehicle. Slight adjustments in the positions of the L/R and F/B antennas may be necessary to make the zero points fall directly in front of the vehicle (neither left nor right LED on) and at the center of the antennas (neither front nor back LED on).

Try the same procedure on 440 MHz. You may have to flip the PHASE switches when you move to another band, even when using the same receiver. Remember that the total length of the 440-MHz antennas must be 1/4 λ or less, and the antennas must be placed less than 1/4 λ apart. The results on 440 MHz probably won't be as consistent as the results on 2 meters, as there is likely to be a lot more multipath propagation caused by the irregular shape of the vehicle.

### Fox Hunting

Before heading out to find the fox, check to be certain the LRFB box is working properly. Tune to the fox's frequency and drive off. Turning on the DAMPING switch stabilizes the indication as you drive along. Follow indications generated as you travel over the road or street. If an indication is constant for 15 or 20 seconds while you're moving down the road, it's probably the true direction to the fox. It's possible to have a reflection from a mountain over a long distance down the road, however. When you can hear the fox with no antenna, it's time to get out of the car, switch to the hand-held system and hunt for the fox on foot.

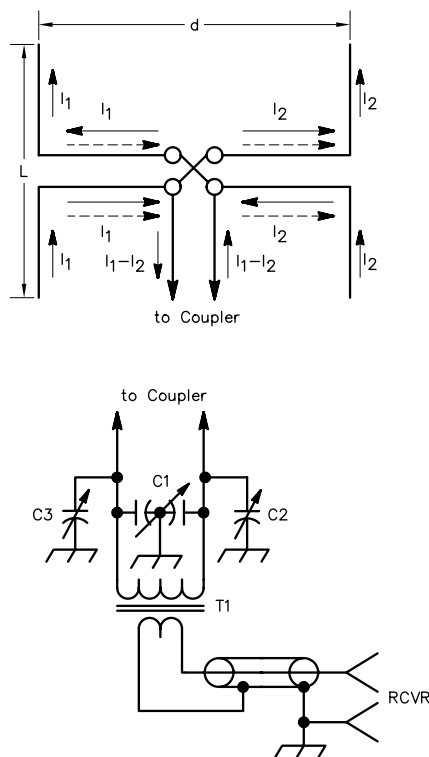
If you switch to a new receiver, you may have to readjust R4, CLOCK FREQ. That's because both receivers may not have the same audio bandwidth. Author WA9BVS forgot this while chasing a balloon once and the results were comical. When chasing balloons with ham radio transmitters, the readings you get are likely to be confusing when the balloon is at a high angle with respect to the plane of the car top. Use a hand-held Yagi to verify the balloon location. Even with a simple buzzbox, you should be able to find a

keyed transmitter.

### AN ADCOCK ANTENNA

Information in this section is condensed from an August 1975 *QST* article by [Tony Dorbeck, K1FM](#), ex-W1YNC. Earlier in this chapter it was mentioned that loops are adequate in applications where only the ground wave is present. But the question arises, what can be done to improve the performance of an RDF system for sky-wave reception? One type of antenna that has been used successfully for this purpose is the Adcock antenna. There are many possible variations, but the basic configuration is shown in **Fig 44**.

The operation of the antenna when a vertically polarized wave is present is very similar to a conventional loop. As can be seen from Fig 44, currents I1 and I2 will be induced in the vertical members by the passing wave. The output current in the transmission line will be equal to their difference. Consequently, the directional pattern will be identical to the loop with a null broadside to the plane of the elements and with maximum gain occurring in end-fire fashion. The magnitude of the difference current will be proportional to the spacing, d, and the length of the elements. Spacing and length are not critical, but somewhat more gain will occur for larger dimensions than for smaller ones. In an experimental model, the spacing was 21 feet (approximately 0.15



**Fig 44—A simple Adcock antenna and suitable coupler (see text).**

wavelength at 7 MHz) and the element length was 12 feet.

Response of the Adcock antenna to a horizontally polarized wave is considerably different from that of a loop. The currents induced in the horizontal members (dashed arrows in Fig 44) tend to balance out regardless of the orientation of the antenna. This effect is borne out in practice, since good nulls can be obtained under sky-wave conditions that produce only poor nulls with small loops, either conventional or ferrite-loop models. Generally speaking, the Adcock antenna has very attractive properties for fixed-station RDF work or for semi-portable applications. Wood, PVC tubing or pipe, or other nonconducting material is preferable for the mast and boom. Distortion of the pattern may result from metal supports.

Since a balanced feed system is used, a coupler is needed to match the unbalanced input of the receiver. It consists of T1, which is an air-wound coil with a two-turn link wrapped around the middle. The combination is then resonated to the operating frequency with C1. C2 and C3 are null-clearing capacitors. A low-power signal source is placed some distance from the Adcock antenna and broadside to it. C2 and C3 are then adjusted until the deepest null is obtained. The coupler can be placed on the ground below the wiring-harness junction on the boom and connected by means of a short length of 300-ohm twin-lead. A length of PVC tubing used as a mast facilitates rotation and provides a means of attaching a compass card for obtaining bearings.

Tips on tuning and adjusting a fixed-location RDF array are presented earlier in this chapter. See the section, "[RDF System Calibration and Use](#)."

## BIBLIOGRAPHY

Source material and more extended discussion of topics covered in this chapter can be found in the references given below and in the textbooks listed at the end of [Chapter 2](#).

- W. U. Amphar, "Unidirectional Loops for Transmitter Hunting," *QST*, Mar 1955.
- G. Bonaguide, "HF DF—A Technique for Volunteer Monitoring," *QST*, Mar 1984.
- D. S. Bond, *Radio Direction Finders*, 1st edition (New York: McGraw-Hill Book Co).
- R. E. Cowan and T. A. Beery, "Direction Finding with the Interferometer," *QST*, Nov 1985.
- D. DeMaw, "Beat the Noise with a Scoop Loop," *QST*, Jul 1977.
- D. DeMaw, "Maverick Trackdown," *QST*, Jul 1980.
- T. Dorbeck, "Radio Direction-Finding Techniques," *QST*, Aug 1975.
- D. T. Geiser, "Double-Ducky Direction Finder," *QST*, Jul 1981.
- D. T. Geiser, "The Simple Seeker," *The ARRL Antenna Compendium, Vol 3*, p 126.
- N. K. Holter, "Radio Foxhunting in Europe," Parts 1 and 2, *QST*, Aug and Nov 1976.
- J. Isaacs, "Transmitter Hunting on 75 Meters," *QST*, Jun 1958.
- H. Jasik, *Antenna Engineering Handbook*, 1st edition (New York: McGraw-Hill, 1961).
- R. Keen, *Wireless Direction Finding*, 3rd edition (London: Wireless World).
- J. Kraus, *Antennas*, 2nd edition (New York: McGraw-Hill Book Co, 1988).
- J. Kraus, *Electromagnetics*, 4th edition (New York: McGraw-Hill Book Co, 1992).
- C. M. Maer, Jr., "The Snoop-Loop," *QST*, Feb 1957.
- M. C. Mallette, "The Four-Way DFER," *QST*, Nov 1995. A set of two PC boards is available from FAR Circuits for the "Four-Way DFER" project. 18N640 Field Ct, Dundee, IL 60118-9269, tel 708-576-3540 (voice and fax). Note: No component pads for C15 exist. Mount C15 between U2 pin 5 and ground on the bottom (foil) side of the board. A PC-board template package is available from the ARRL free of charge. Send your request for the MALLETT 4-WAY DFER, along with a business size SASE, to the Technical Department Secretary, 225 Main St, Newington, CT 06111-1494.
- L. R. Norberg, "Transmitter Hunting with the DF Loop," *QST*, Apr 1954.
- P. O'Dell, "Simple Antenna and S-Meter Modification for 2-Meter FM Direction Finding," *Basic Amateur Radio*, *QST*, Mar 1981.
- Ramo and Whinnery, *Fields and Waves in Modern Radio* (New York: John Wiley & Sons, 1944).
- F. Terman, *Electronic and Radio Engineering* (New York: McGraw-Hill Book Co, 1955).
- Radio Direction Finding*, published by the Happy Flyer, 1811 Hillman Ave, Belmont, CA 94002.

For more information on direction finding, see *The ARRL Handbook* and *Transmitter Hunting: Radio Direction Finding Simplified*, by Joe Moell, K0OV, and Thomas Curlee, WB6UZZ. These books are available from your local dealer or can be ordered directly from ARRL.

# Chapter 15

# Portable Antennas

For many amateurs, the words *portable antennas* may conjure visions of antenna assemblies that can be broken down and carried in a backpack, suitcase, golf bag, or what-have-you, for transportation to some out-of-the way place where they will be used. Or the vision could be of larger arrays that can be disassembled and moved by pickup truck to a Field Day site, and then erected quickly on temporary supports. Portable antennas come in a wide variety of sizes and shapes, and can be used on any amateur frequency.

Strictly speaking, the words “portable antenna” really means *transportable antenna*—one that is moved to some (usually temporary) operating position for use. As such, portable antennas are not placed into service when they are being transported. This puts them in a different class from mobile antennas, which are intended to be used while in motion. Of course this does not mean that mobile antennas cannot be used during portable operation. Rather, true portable antennas are designed to be packed up and moved, usually with quick reassembly being one of the design requisites. This chapter describes antennas that are designed for portability. However, many of these antennas can also be used in more permanent installations.

Any of several schemes can be employed to support an antenna during portable operation. For HF antennas made of wire, probably the most common support is a conveniently located tree at the operating site. Temporary, lightweight masts are also used. An aluminum extension ladder, properly guyed, can serve as a mast for Field Day operation. Such supports are discussed in [Chapter 22](#).

## A SIMPLE TWIN-LEAD ANTENNA FOR HF PORTABLE OPERATION

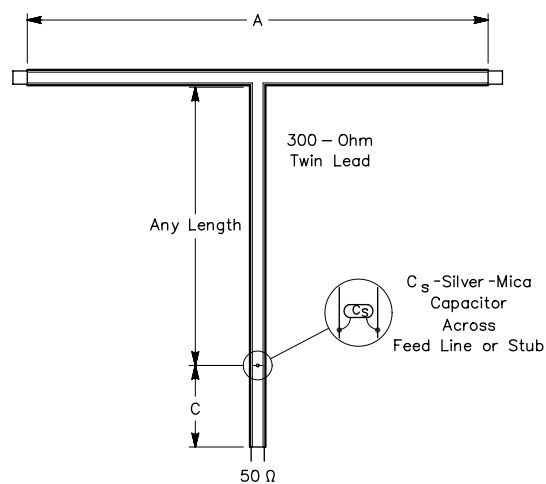
The typical portable HF antenna is a random-length wire flung over a tree and end-fed through an antenna tuner. Low-power antenna tuners can be made quite compact, but each additional piece of necessary equipment makes portable operation less attractive. The station can be simplified by using resonant impedance-matched antennas for the bands of interest. Perhaps the simplest antenna of this type is the half-wave dipole, center-fed with 50- or 75- $\Omega$  coax. Unfortunately, RG-58, RG-59 or RG-8 cable is quite heavy

and bulky for backpacking, and the miniature cables such as RG-174 are too lossy.

A practical solution to the coax problem, developed by Jay Rusgrove, W1VD, and Jerry Hall, K1TD, is to use folded dipoles made from lightweight TV twin-lead. The characteristic impedance of this type of dipole is near 300  $\Omega$ , but this can easily be transformed to a 50- $\Omega$  impedance. The transformation is obtained by placing a lumped capacitive reactance at a strategic distance from the input end of the line. **Fig 1** illustrates the construction method and gives important dimensions for the twin-lead dipole.

A silver-mica capacitor is shown for the reactive element, but an open-end stub of twin-lead can serve as well, provided it is dressed at right angles to the transmission line for some distance. The stub method has the advantage of easy adjustment of the system resonant frequency.

The dimensions and capacitor values for twin-lead dipoles for the HF bands are given in [Table 1](#). To preserve



**Fig 1—A twin-lead folded dipole makes an excellent portable antenna that is easily matched to 50- $\Omega$  equipment. See text and [Table 1](#) for details.**

**Table 1****Twin-Lead Dipole Dimensions and Capacitor Values**

Frequency	Length A	Length C	$C_s$	Stub Length
3.75 MHz	124' 9 $\frac{1}{2}$ "	13' 0"	289 pF	37' 4"
7.15	65' 5 $\frac{1}{2}$ "	6' 10"	151 pF	19' 7"
10.125	46' 2 $\frac{1}{2}$ "	4' 10"	107 pF	13' 10"
14.175	33' 0"	3' 5 $\frac{1}{2}$ "	76 pF	9' 10 $\frac{1}{2}$ "
18.118	25' 10"	2' 8 $\frac{1}{2}$ "	60 pF	7' 9"
21.225	22' 1 $\frac{1}{2}$ "	2' 3 $\frac{1}{2}$ "	51 pF	6' 7"
24.94	18' 9"	1' 11 $\frac{1}{2}$ "	43 pF	5' 7 $\frac{1}{2}$ "
28.5	16' 5"	1' 8 $\frac{1}{2}$ "	38 pF	4' 11"

the balance of the feeder, a 1:1 balun must be used at the end of the feed line. In most backpack QRP applications the balance is not critical, and the twin-lead can be connected directly to a coaxial output jack—one lead to the center contact, and one lead to the shell.

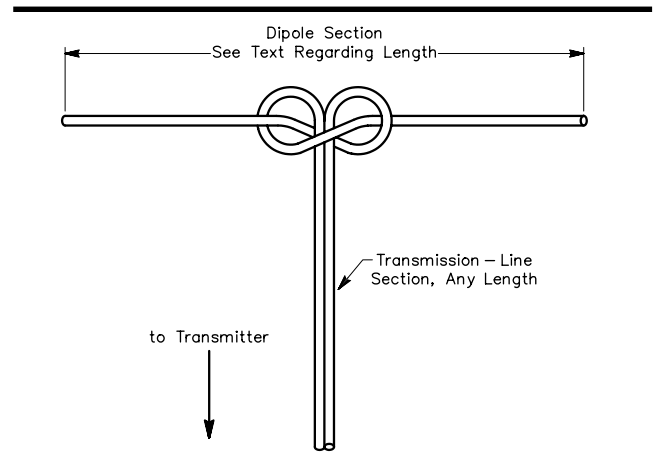
Because of the transmission-line effect of the shorted-radiator sections, a folded dipole exhibits a wider bandwidth than a single-conductor type. The antennas described here are not as broad as a standard folded dipole because the impedance-transformation mechanism is frequency selective. However, the bandwidth should be adequate. An antenna cut for 14.175 MHz, for example, will present an SWR of less than 2:1 over the entire 14-MHz band.

### ZIP-CORD ANTENNAS

Zip cord is readily available at hardware and department stores, and it's not expensive. The nickname, *zip cord*, refers to that parallel-wire electrical cord with brown or white insulation used for lamps and many small appliances. The conductors are usually #18 stranded copper wire, although larger sizes may also be found. Zip cord is light in weight and easy to work with.

For these reasons, zip cord can be pressed into service as both the transmission line and the radiator section for an emergency dipole antenna system. This information by [Jerry Hall, K1TD](#), appeared in *QST* for March 1979. The radiator section of a zip-cord antenna is obtained simply by "unzipping" or pulling the two conductors apart for the length needed to establish resonance for the operating frequency band. The initial dipole length can be determined from the equation  $\ell = 468/f$ , where  $\ell$  is the length in feet and  $f$  is the frequency in MHz. (It would be necessary to unzip only half the length found from the formula, since each of the two wires becomes half of the dipole.) The insulation left on the wire will have some loading effect, so a bit of length trimming may be needed for exact resonance at the desired frequency.

For installation, you may want to use the electrician's knot shown in **Fig 2** at the dipole feed point. This is a balanced knot that will keep the transmission-line part of the system



**Fig 2**—This electrician's knot, often used inside lamp bases and appliances in lieu of a plastic grip, can also serve to prevent the transmission-line section of a zip-cord antenna from unzipping itself under the tension of dipole suspension. To tie the knot, first use the right-hand conductor to form a loop, passing the wire behind the unseparated zip cord and off to the left. Then pass the left-hand wire of the pair behind the wire extending off to the left, in front of the unseparated pair, and thread it through the loop already formed. Adjust the knot for symmetry while pulling on the two dipole wires.

from unzipping itself under the tension of dipole suspension. This way, if zip cord of sufficient length for both the radiator and the feed line is obtained, a solder-free installation can be made right down to the input end of the line.

(Purists may argue that knots at the feed point will create an impedance mismatch or other complications, but as will become evident in the next section, this is not a major consideration.) Granny knots (or any other variety) can be used at the dipole ends with cotton cord to suspend the system. You end up with a light-weight, low-cost antenna system that can serve for portable or emergency use.

But just how efficient is a zip-cord antenna system? Since it is easy to locate the materials and simple to install, how about using such for a more permanent installation? Upon casual examination, zip cord looks about like 72- $\Omega$  balanced feed line. Does it work as well?

### Zip Cord as a Transmission Line

To determine the electrical characteristics of zip cord as a radio-frequency transmission line, a 100-foot roll was subjected to tests in the ARRL laboratory with an RF impedance bridge. Zip cord is properly called *parallel power cord*. The variety tested was manufactured for GC Electronics, Rockford, IL, being 18-gauge, brown, plastic-insulated type SPT-1, GC cat. no. 14-118-2G42. Undoubtedly, minor variations in the electrical-characteristics will occur among similar cords from different manufacturers, but the results presented here are probably typical.

The characteristic impedance was determined to be 107  $\Omega$  at 10 MHz, dropping in value to 105  $\Omega$  at 15 MHz and to a slightly lower value at 29 MHz. The nominal value

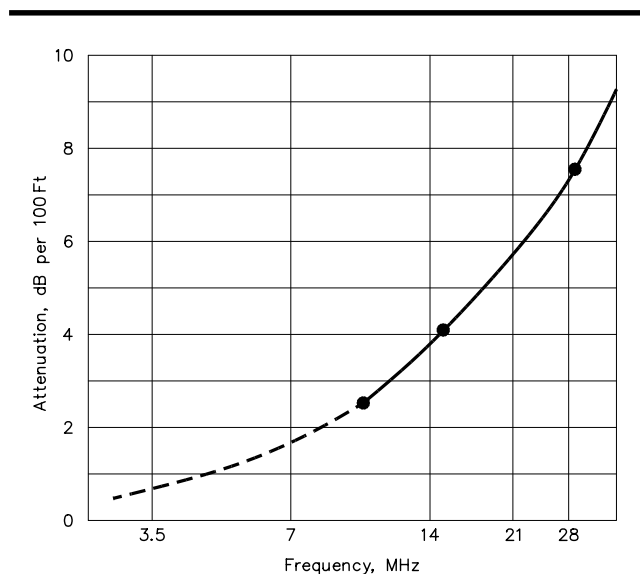
is 105  $\Omega$  at HF. The velocity factor of the line was determined to be 69.5%.

Who needs a 105- $\Omega$  line, especially to feed a dipole? A dipole in free space exhibits a feed-point resistance of 73  $\Omega$ , and at heights above ground of less than  $\frac{1}{4}$  wavelength the resistance can be even lower. An 80-meter dipole at 35 feet over average soil, for example, will exhibit a feed-point resistance of about 35  $\Omega$ . Thus, for a resonant antenna, the SWR in the zip-cord transmission line can be 105/35 or 3:1, and maybe even higher in some installations. Depending on the type of transmitter in use, the rig may not like working into the load presented by the zip-cord antenna system.

But the really bad news is still to come—line loss! **Fig 3** is a plot of line attenuation in decibels per hundred feet of line versus frequency. Chart values are based on the assumption that the line is perfectly matched (sees a 105- $\Omega$  load as its terminating impedance).

In a feed line, losses up to about 1 decibel or so can be tolerated, because at the receiver a 1-dB difference in signal strength is just barely detectable. But for losses above about 1 dB, beware. Remember that if the total losses are 3 dB, half of your power will be used just to heat the transmission line. Additional losses over those charted in Fig 3 will occur when standing waves are present. (See [Chapter 24](#).) The trouble is, you can't use a 50- or 75- $\Omega$  SWR instrument to measure the SWR in zip-cord line accurately.

Based on this information, we can see that a hundred feet or so of zip-cord transmission line on 80 meters might be acceptable, as might 50 feet on 40 meters. But for longer lengths and higher frequencies, the losses become appreciable.



**Fig 3—Attenuation of zip cord in decibels per hundred feet when used as a transmission line at radio frequencies. Measurements were made only at the three frequencies where plot points are shown, but the curve has been extrapolated to cover all high-frequency amateur bands.**

## Zip Cord Wire as the Radiator

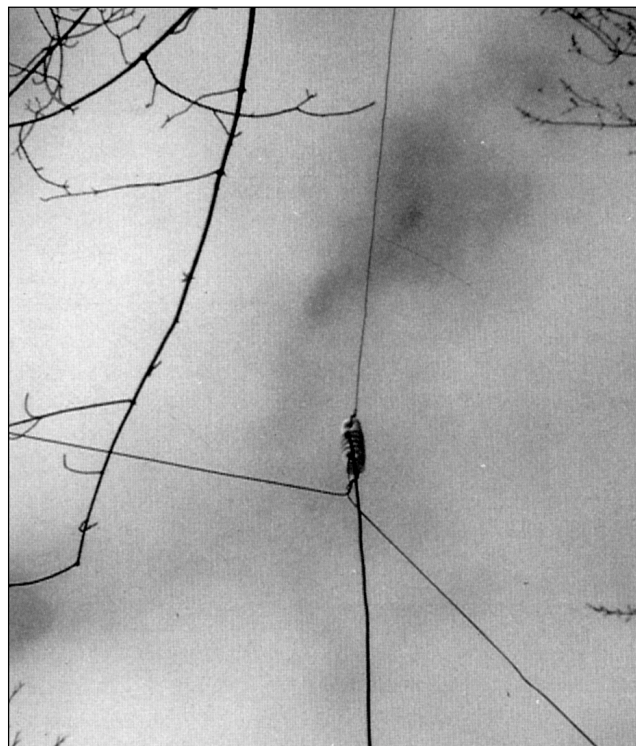
For years, amateurs have been using ordinary copper house wire as the radiator section of an antenna, erecting it without bothering to strip the plastic insulation. Other than the loading effects of the insulation mentioned earlier, no noticeable change in performance has been noted with the insulation present. And the insulation does offer a measure of protection against the weather. These same statements can be applied to single conductors of zip cord.

The situation in a radiating wire covered with insulation is not quite the same as in two parallel conductors, where there may be a leaky dielectric path between the two conductors. In the parallel line, it is the current leakage that contributes to line losses. This leakage current is set up by the voltage potential that exists on the two adjacent wires. The current flowing through the insulation on a single radiating wire is quite small by comparison, and so as a radiator the efficiency is high.

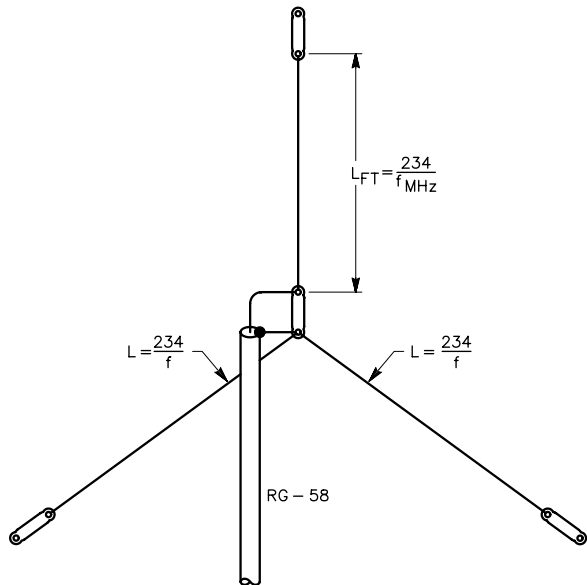
In short, communications can certainly be established with a zip-cord antenna in a pinch on 160, 80, 40, 30 and perhaps 20 meters. For higher frequencies, especially with long line lengths for the feeder, the efficiency of the system is so low that its value becomes questionable.

## A TREE-MOUNTED HF GROUND-PLANE ANTENNA

A tree-mounted, vertically polarized antenna may sound silly. But is it really? Perhaps engineering references



**Fig 4—The feed point of the tree-mounted ground-plane antenna. The opposite ends of the two radial wires may be connected to stakes or other convenient points.**



**Fig 5—Dimensions and construction of the tree-mounted ground-plane antenna.**

do not recommend it, but such an antenna does not cost much, is inconspicuous, and it works. This idea was described by [Chuck Hutchinson, K8CH](#), in *QST* for September 1984.

The antenna itself is simple, as shown in [Fig 4](#). A piece of RG-58 cable runs to the feed point of the antenna, and is attached to a porcelain insulator. Two radial wires are soldered to the coax-line braid at this point. Another piece of wire forms the radiator. The top of the radiator section is suspended from a tree limb or other convenient support, and in turn supports the rest of the antenna.

The dimensions for the antenna are given in [Fig 5](#). All three wires of the antenna are  $\frac{1}{4}$  wavelength long. This generally limits the usefulness of the antenna for portable operation to 7 MHz and higher bands, as temporary supports higher than 35 or 40 feet are difficult to come by. Satisfactory operation might be had on 3.5 MHz with an inverted-L configuration of the radiator, if you can overcome the accompanying difficulty of erecting the antenna at the operating site.

The tree-mounted vertical idea can also be used for fixed station installations to make an invisible antenna. Shallow trenches can be slit for burying the coax feeder and the radial wires. The radiator itself is difficult to see unless you are standing right next to the tree.

### A PORTABLE DIPOLE FOR 80 TO 2 METERS

This dipole antenna, described by Robert Johns, W3JIP, in August 1998 *QST*, can be used for any band from 80 through 2 meters. One half of the dipole is an inductively loaded aluminum tube. Its length is adjustable from 4 to 11 feet, depending on how much room is available. The other half is flexible insulated wire that can be spooled out as



**Fig 6—At top, the portable antenna in some of the many places it may be mounted around the house, porch and yard. At right, the simple ground-mounted legs that make a tripod.**

necessary. The tube is supported by a flagpole bracket attached to a long carpenter's clamp. The clamp mounts the antenna to practically anything: a windowsill, railing, a chair or post. If there is no structure to mount the antenna (a parking lot or the beach), the clamp attaches to two light wooden legs to form a tripod, as shown in [Fig 6](#).

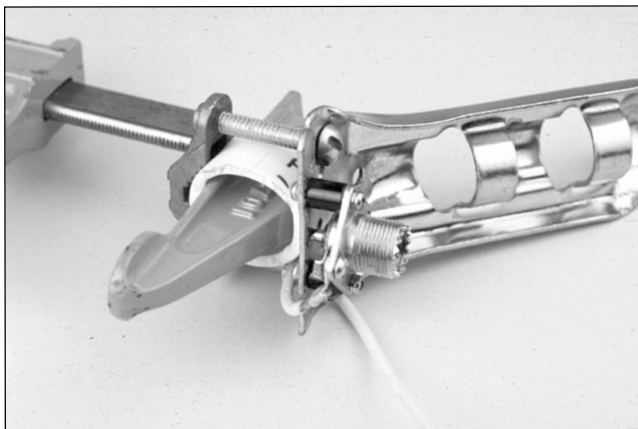
The key to mounting flexibility is the large clamp. The key to electrical flexibility is a large adjustable coil that lets you resonate the tube on many bands. The coil is wound with #8 aluminum ground wire from RadioShack. The form is a four-inch (4½-inch OD) styrene drain coupling from the Home Depot or a large plumbing supply store. A movable tap adjusts the inductance to tune the upright tube to the desired band. The wire half of the antenna is always a bit less than  $\lambda/4$  on each band. Hang it from any convenient support or drape it over bushes to keep it off the ground.

### Construction

The 18-inch carpenter's clamp (sometimes called a *bar clamp*, such as Jorgensen's No. 3718) and flagpole bracket that takes a ¾-inch pole are common hardware items. Insulate the bracket from the clamp jaw with a 1½-inch length of 1-inch PVC pipe (see [Fig 7](#)). Hammer the PVC over the end clamp jaw to make it take the shape of the jaw. Secure the flagpole bracket to PVC with a large ground clamp (for ½ or 1-inch conduit). The ground clamp includes ¼-inch bolts; enlarge the flagpole bracket holes to accept them. Some flagpole brackets have an integral cleat; the author hammered the cleat ears flat on his.

Mount an SO-239 chassis connector on the flagpole bracket using RadioShack insulated standoffs (276-1381). The standoffs tightly press the center pin of the SO-239 against the bracket surface; no other connection is needed. Other mounting hardware may require a connection from the coax center conductor to the bracket. The spooled wire's inner end wraps around a standoff and connects to a ring terminal





**Fig 7—The flagpole bracket that supports the tubing elements is clamped to the long carpenter's clamp, but insulated from it by a small section of 1-inch PVC pipe. A coax connector is mounted to the bracket and the spool of wire is attached to the coax connector.**

under a screw holding the SO-239 flange to the standoff.

The 1 × 2-inch wooden legs for the tripod are each 30 inches long. Bolt them together at one end with a 1 or 1 1/4-inch-long bolt. Countersink the bolt head and nut below the surface of the wood so they don't interfere with the clamp jaws.

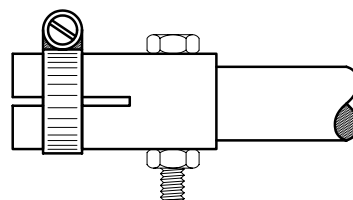
### Aluminum Element

You can make this element from three lengths of telescoping aluminum tubing ( $3/4$ ,  $5/8$  and  $1/2$  inch, 0.058-inch walls). The author used tubing with thinner walls for less weight and easier handling. A 45-inch-long,  $3/4$ -inch tube fits the flagpole bracket. He chose this length because it and the flagpole bracket make  $\lambda/4$  on 6 meters. The two outer tubes are both  $5/8$  inch, made by cutting a seven-foot aluminum clothesline pole in halves. They are joined together with a copper coupling ( $5/8$  inch ID) for  $1/2$ -inch copper pipe. The coupling is bolted to one of the  $5/8$ -inch sections, and a slot is cut in the free half of the coupling. The remaining  $5/8$ -inch tube is inserted there and secured with a hose clamp. See Fig 8.

One  $5/8$ -inch tube slides into the  $3/4$ -inch tube to provide a continuously variable element length from about 4 to 7 1/2 feet. This extends from 7 1/2 to 11 feet when the two  $5/8$ -inch sections are joined together.

### Loading Coil

The loading coil has 12 turns of bare aluminum wire spaced to fill the 3 1/2-inch length of the drain coupling. Drill  $9/64$ -inch holes at the ends of the coil form to accept the ends of the coil wire. (See Fig 9.) To wind the coil, feed four inches of wire through the form, make a sharp bend in the wire and start winding away from the nearby mounting hole. Wind 12 turns on the form, spacing them only approximately. Cut the wire for a 4-inch lead and feed it through the other hole in the form. Tighten the wire as best you can and bend it into another acute angle where it passes into the form. Space the

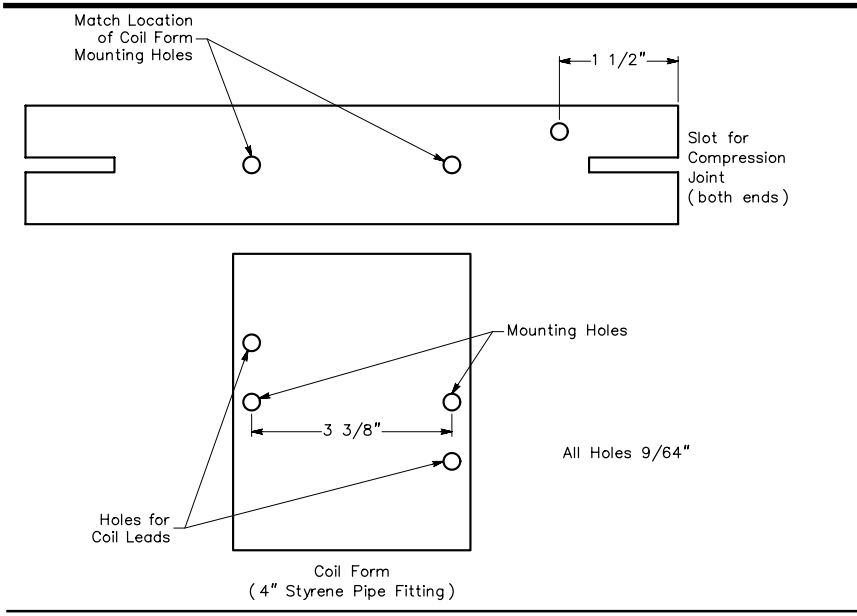


**Fig 8—The joint between two sections of  $5/8$ -inch tubing is made from a  $1/2$ -inch copper pipe coupling, bolted to one section and hose clamped to the other.**

turns about equally, but don't fuss with them. Final spacing will be set after the wire is tightened.

Tighten the coil wire by putting a screwdriver or a needle-nose pliers jaw under one turn, and pry the wire up and away from the surface of the coil form. While this can be done anywhere, it's best to put these kinks on the backside, away from the mounting shaft. Put kinks in every other turn, removing any slack from the coil and holding the turns in place. Should the coil ever loosen, simply retighten it with a screwdriver. If you prefer, glue the coil turns in place with epoxy or coil dope. Use a thin bead of glue that won't interfere with the clip that connects to the coil.

The coil form mounts on a nine-inch-long  $3/4$ -inch PVC



**Fig 9—Holes to be drilled in the styrene coupling and the 3/4-inch PVC pipe. All holes are 9/64-inch diameter, to provide clearance for #6-32 bolts. The hole 1 1/2 inches from one end holds a bolt that serves as a stop, so that the antenna tube does not slide in too far. Space the holes for coil leads far enough from the mounting holes to clear the 3/4-inch pipe.**

pipe. (See Fig 9 and Fig 10.) The inside diameter is slightly larger than the 3/4-inch aluminum, but slotting the PVC and tightening it with a hose clamp secures the tube. (Use a wide saw to cut these slots, not a hacksaw.) The coil form mounts to the PVC pipe with #6-32 x 1 1/2-inch bolts. A five-inch long, 3/4-inch aluminum tube permanently attaches to one end of the coil assembly and slides into the flagpole bracket. One end of the coil wire connects to this short tube. Flatten the wire end by hammering it on something hard, then drill a 9/64-inch hole in the flattened end and attach it to the short tube with a #6-32 x 1-inch bolt. Tighten the bolt until the 1/2-inch tube starts to flatten. This will keep pressure on the aluminum-to-aluminum joint.

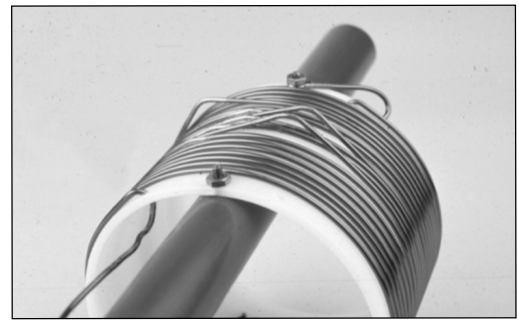
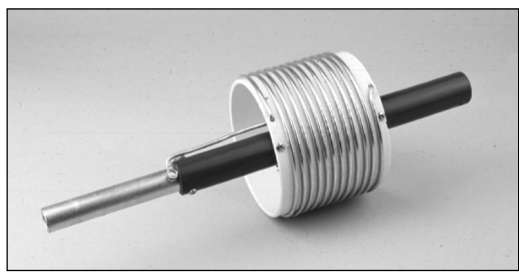
The aluminum element slides into the opposite end of the coil assembly. The hose clamp there can be tightened until the element just slides in snugly.

A 12-inch clip lead connects the aluminum element to the coil. Bolt the plain wire end to the 3/4-inch tube three inches from its end. Many alligator clips will fit in the space between the turns of the coil (about 3/16 inch), but W3JIP preferred using a solid-copper clip (Mueller TC-1). Cut off most of the jaws, so that only the part close to the hinge grabs the coil. This shorter lever grips very tightly.

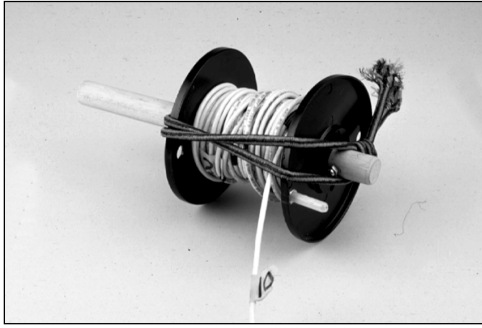
**Wire and Spool**

The lower half of the antenna is insulated wire that is about λ/4 on the band of operation. The wire is pulled from the spool, and the remaining wire forms an inductance that doesn't add much to the antenna length. The Home Depot sells #12 and #14 insulated stranded copper wire in 50 and 100 foot lengths, on plastic spools. (See Fig 11.) A 1/2-inch dowel fits into the spool to make a handle and spool axle. Bolts through the dowel on either side of the spool hold it in place. A crank handle is made by putting a one-inch-long bolt through the spool flange.

The author calibrates the wire on the spool with markers and electrical-tape flags. There's a mark (from a permanent marking pen) at each foot, a black flag every five feet and a length-marked colored flag every 10 feet. Simply mark the length for each band, if you like.



**Fig 10—Top photo shows the loading coil for the 20, 30, and 40-meter band coverage. The short aluminum tube on the coil slides into the flagpole bracket, and the tubing element slides into the other end of the PVC pipe. The wire and clip connect the element to the coil. Bottom photo shows the coil for operating the antenna on 80 meters. This is placed in the flagpole bracket and the 40-meter aluminum coil plus the tubing element is inserted into it.**



**Fig 11**—The wire spool has a wooden axle/handle and small handle for winding the wire. A bungee cord stretched over the spool and around the axle prevents the wire from unwinding.

Make sure you prevent the wire from unspooling, especially when it's hanging from a window mounting. A heavy rubber band works, but it doesn't last long. A better solution is a loop of light bungee cord, preferably with a knot for grip. The bungee loop runs from the axle/handle around the spool making a half twist on the way, and then passes over the axle end on the other side of the spool. (See Fig 11.)

### Operation

**Table 2** lists element length, wire length and coil tap point for various bands. When the number of turns shown is zero, the coil is not needed. On all bands except 6 meters, you can simply bypass the coil with the clip lead—the extra length just lowers the frequency a bit. For 6 meters, the coil *must* be removed. The location of the unspooled wire greatly affects the settings, so these numbers are only starting points. The lengths in the table were taken with the wire one to three feet above ground, draped over and through bushes and flowerbeds. The antenna will still work if the wire is lying on the ground, but it will require less unspooled wire to resonate. A balun is not needed, and an SWR analyzer is very helpful while adjusting this antenna.

The SWR is less than 1.5:1 on all bands, and it's usually below 1.2:1. Occasionally, a band shows a higher SWR (still less than 2:1), but that can always be lowered by adjusting the length or location of the lower wire. Never set up the antenna where it could fall and injure someone, or where the unwary could get an RF burn by touching it.

The author's results with this antenna have been excellent, both from home and on vacation. If you haven't yet operated from a seashore location, be prepared for a pleasant surprise! The good ground afforded by the salt water really makes a difference.

### 80 Meters

It's easy to add this lower frequency band. [Fig 10B](#) shows a 35  $\mu$ H coil for 80 meters. It's constructed and tightened just like the 40-meter coil, but has 20 turns of #12 magnet wire.

To operate on 75/80 meters, insert the new coil into the

**Table 2**

**Element Length, Wire Length and Coil Tap Points**

	Tubing Length (feet)	Coil Turns	Wire Length (feet)
6 meters	4	0	4
10 meters	7	0	8
	4	1.7	7
12 meters	8	0	8.3
	4	1.8	9
15 meters	10	0	10.3
	8	1.8	10
	4	3.5	10
17 meters	11	0	13
	8	2.2	13
	4	4.2	13
	4	6.2	16
20 meters	11	1	16
	8	4	16
	4	6.2	16
30 meters	11	4	24
	8	7	24
	4	10.5	24
40 meters	11	9	32
	8	12	32

flagpole bracket and plug the 40-meter coil into it. Tune across the band with the movable tap on the 40-meter coil. This varies antenna resonance from below 3.5 to above 4.0 MHz, with the full 11 feet of tubing extended. If your version doesn't achieve this tuning range, adjust the spacing of the turns on the 80-meter coil.

The 80-meter coil has a five-inch length of  $\frac{3}{4}$ -inch aluminum tube inserted into one end of the  $\frac{1}{2}$ -inch PVC pipe that supports the coil form. One end of the coil is connected to this aluminum tube. The other end is secured under the bolt that holds the coil form to the PVC pipe. A second clip lead connects the base of the 40-meter coil to the outer end of the larger coil. The length of wire on the spool must also be increased to about 64 feet.

### 2 Meters

A  $\lambda/2$  dipole for 2 meters can be made with about 15 inches of  $\frac{1}{2}$ -inch aluminum tubing in the flagpole bracket, and 18 inches of wire. The tubing element is shorter than normal for 2 meters because the bracket is also part of the antenna. You can also shorten the 6-meter wire a bit and operate the 6-meter antenna as a  $3\lambda/2$  on 2 meters, with a somewhat higher SWR.

### Continuous Coverage

With easily changed element lengths and a continuously variable loading coil, you may operate the antenna on any frequency from 6.5 to 60 MHz, if coverage for other services is needed. With taps in the 80-meter coil at 8, 11 and 14 turns, the antenna will also tune from 4 to 7 MHz.

## THE HF CABOVER ANTENNA

If you have ever had the pleasure of traveling across the country with an HF mobile in a camper, trailer or motor home you may want to duplicate this antenna for use when you park. This antenna was described by Jim Ford, N6JF, in *The ARRL Antenna Compendium Vol 5*.

The author's camper has limited spots on which to mount an HF mobile antenna. The back ladder is a convenient place to mount a small mobile whip. However, the efficiency of typical mobile center-loaded antennas, depending on coil Q and other assumptions, is often less than 2% for 80 meters and 10% for 40 meters. (These numbers come from the excellent, easy-to-use *MOBILE* antenna design program by Leon Braskamp, AA6GL, which is on the CD-ROM bundled with this book.)

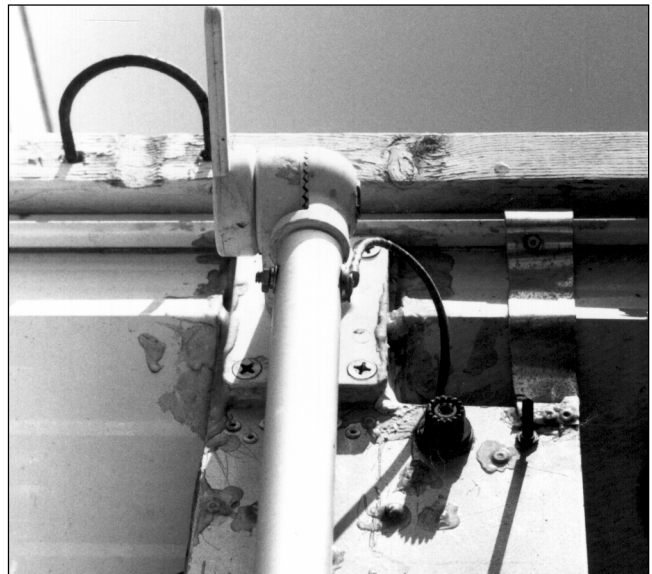
At some locations, N6JF used an 80-meter dipole, which was very efficient and worked great on all bands when fed with open-wire line and an antenna tuner. However, it took over 40 minutes to set up and about 20 minutes to tear down, working with a sling shot and many tree snags. This is too much time to make a schedule or for an early morning departure, although it's OK if you plan to stay for a while. Even more important, there were often too many trees or other barriers (perhaps some even social) to allow putting up the dipole at a campsite.

When this happened he was stuck with the mobile antenna with poor efficiency. There had to be a better antenna for camper operation. The author decided on a large vertical.

A telescoping aluminum extension pole used for roller painting would make a good bottom section for the loaded vertical. These are available at many local home supply centers. The author's was 1 inch in diameter and 6 feet long, telescoping to almost 12 feet. He disassembled both sections and cross-cut a 1-inch slot in the top of the bottom section with a hacksaw to allow compression clamping with a hose clamp. The tip of the top section was fitted with an aluminum plug that had a  $3/8$ -24 hole tapped in it. This procedure was a simple machine-shop operation. The plug was pounded into the top section and is quite snug. He tapped some set screws through the pole into the plug, however, just to be sure. An insulated, lay-down marine antenna mount fit perfectly into the bottom of the aluminum base and was secured with a bolt that also served as the electrical connection from the capacitor matching box. See **Fig 12** showing the aluminum base plate, the laydown mount and the antenna mast itself lowered down the back of the camper. **Fig 13** shows the layout of the back of the camper, with the antenna on the right-hand side, laid down for travel.

The variable capacitor in the matching box is a surplus three-section 365-pF broadcast tuning capacitor. Two of three sections are connected in parallel and a switch parallels in the third section, along with an extra 800 pF mica capacitor for use on 80 meters. See the schematic in **Fig 14**.

The capacitor assembly was put in a custom-glued Plexiglas box to keep out the weather and mounted to a piece of plate aluminum, along with an SO-239 connector. The



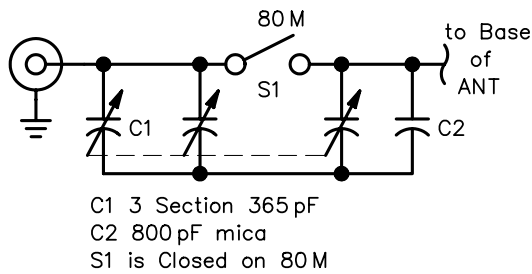
**Fig 12**—Photo of aluminum base plate, showing details of mounting to the camper. The four banana-plug jacks on the bottom are for extra radials, if desired.



**Fig 13**—Photo showing the back of the camper, with the antenna in the lowered position, parallel to the ladder. The “Outback” standby mobile antenna is shown clamped to the left side of the ladder.

aluminum plate was riveted to the camper shell using a lot of aluminum rivets. Do not use steel. N6JF peeled back about a 4-inch wide section of the side of the camper for this direct aluminum-to-aluminum connection. People who are hesitant to modify their campers like this need to find an alternate low-resistance connection method. His camper was old enough not to be an issue.

For an extra low-resistance connection a 1/2-inch aluminum strip was added from the top of the base plate to the camper, as shown in Fig 12 near the 80-meter switch. The tuning knob protrudes from the side of the Plexiglas box. The four bottom holes in the plate are for banana plugs

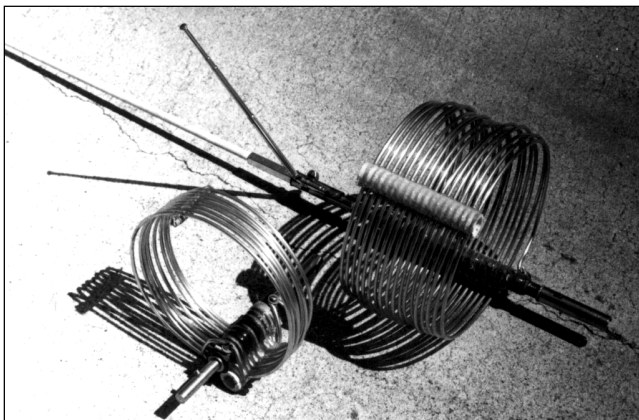


**Fig 14—Schematic of tuning capacitor at base plate. C2 is an 800 pF transmitting mica capacitor. C1 is a three-section 365 pF broadcast tuning capacitor. S1 is closed for 80-meter operation.**

to connect ground radials if extra efficiency is desired. However, the roof of a camper is one of the better places for a mobile antenna, so the author seldom hooks up the radials. When he does use them, the tuning changes only a little.

To keep losses down, N6JF used coils wound with aluminum clothes-line wire on old mobile coil center sections with quick disconnect fittings. See Fig 15, which shows both the 80 and 40 meter coils, together with the top portion of the antenna. An article by Robert Johns, W3JIP, in October 1992 *QST* described techniques for building your own loading coils. The coils ended with a little more inductance than calculated and the author had to remove some turns. Both coils are spaced at 4 turns per inch. The 8-inch long 80-meter coil has 18 turns. The 7-inch long 40-meter coil has 8 turns.

The matching network is actually an L-section step-up match, using the net inductive reactance of the antenna plus the center loading coil. The PVC coil construction technique was described in W3JIP's *QST* article and a follow-up



**Fig 15—Close-up photo of 80 and 40-meter coils, with top section and telescoping whip antenna with swivel bracket for tuning the top section for the higher bands. Note quick-disconnect connectors at top and bottom of both coils. The top whip is a Fiberglass CB whip, used on 80 and 40 meters.**

Technical Correspondence piece in October 1992 *QST*. Basically, it consists of drilling an accurate row of slightly undersized holes along a length of 1/2-inch PVC pipe and then carefully sawing down the center of the row of holes with a hack saw. Then, you trap the coil wires in the grooves between the two sawed halves and tie the two halves together with string. When you are satisfied that everything is proper, you then tighten the string and apply epoxy glue to make it strong and permanent.

One advantage of aluminum clothes line wire is that it is already coiled at the approximate diameter needed when you buy it and it is easy to position on the coil form. The clothes line wire had a plastic coating, which wasn't removed except at the contact points. Once the epoxy dries, this method of construction does a good job of holding the finished coil together and it is lightweight.

The computed coil Q from the *MOBILE* antenna program is about 800 for the 80-meter coil and about 400 for the 40-meter coil. The author accidentally made the 40-meter coil 7 inches in diameter instead of a higher-Q 6 inch diameter. Even so, the whole antenna system with a 9-foot top section calculates as being 56% efficient on 80 meters and 85% for 40 meters.

The removable top section for 80 and 40 meters is a full-size fiberglass CB whip from RadioShack. The fiberglass whip has about a #16 hole in the center of it. Be sure to sand and paint the whip for protection against UV and to protect yourself against fiberglass spurs in the hands. N6JF tried a full-size stainless steel CB whip to get a slightly higher capacitance to ground because of larger conductor size but discovered it was far too heavy. That experience reinforced his decision that aluminum was a far more practical coil and base section material for this project.

Quick-disconnect connectors found years ago at a hamfest were used for both coil forms and for the top section. Bands higher than 40 meters don't need any loading coils and the antenna length can be telescoped to get a 1/4 wavelength. Ten meters doesn't require any top section. Be sure to use some NOALOX or similar compound to prevent corrosion and poor connections at all aluminum joints. This is especially true for the telescoping sections and the aluminum rivets. The matching capacitor is in the circuit at all times but when the 80-meter switch is off you can set the capacitor at minimum (about 14 pF) and it is effectively out of the circuit, even at 10 meters. The author has not tried this antenna on power levels greater than about 100 W but the weakest link would probably be the matching capacitor. The voltage at the matching capacitor is low, so 200 W should be no problem.

You can achieve a 1:1 SWR match for 80 or 40 meters and a good SWR is obtained without retuning the base matching capacitor for approximately 100 kHz on 80 meters and most of 40 meters. The top section, however, does not have such low Q and needs to be tuned. The 2:1 SWR bandwidth on 80 meters is about 25 kHz and 150 kHz for 40 meters. Tuning is accomplished by using a telescoping

FM portable radio antenna connected to the top-section whip with a stainless steel hose clamp. The maximum length of the telescoping section used was 29 inches, and it collapses down to 7 inches. A whip with an elbow was used to adjust the angle of the whip as well. A telescoping whip half the length would still be long enough for the full adjustment of both bands.

Adjustment of the top section is one of the penalties paid to achieve high efficiency for operation on 80 and 40 meters. Substituting an automatic antenna tuner would likely lose efficiency, particularly on 80 meters since the base resistance calculates to about 10  $\Omega$ . N6JF has not tried to make the antenna work on 160 meters. The SWR for the higher bands was good enough without any matching network.

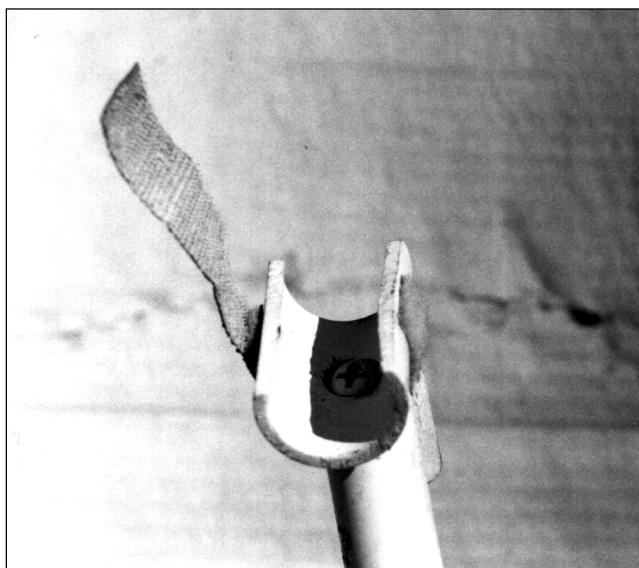
As light as the antenna is, it still won't hold up in a moderate wind without some support guys. N6JF used  $\frac{3}{4}$ -inch and  $\frac{1}{2}$ -inch PVC support pipes in a telescoping arrangement for storage, but expanding to give an approximate 45° support at the top of the bottom section from both directions. One end of the telescoping section was connected to the camper roof with a hinge. The other end formed a snap-fit out of a PVC barrel that was cut length wise. See **Fig 16** and **Fig 17** for details. Even though it formed a good snap fit, N6JF didn't trust the joint for strong winds so he glued a piece of Velcro to the joint to close up the open end. Be careful, though, because Velcro deteriorates with exposure.

Another hose clamp near the top of the bottom section holds an  $\frac{1}{8}$ -inch line taken up the ladder to pull up the antenna without the need of an assistant. The disadvantage is you

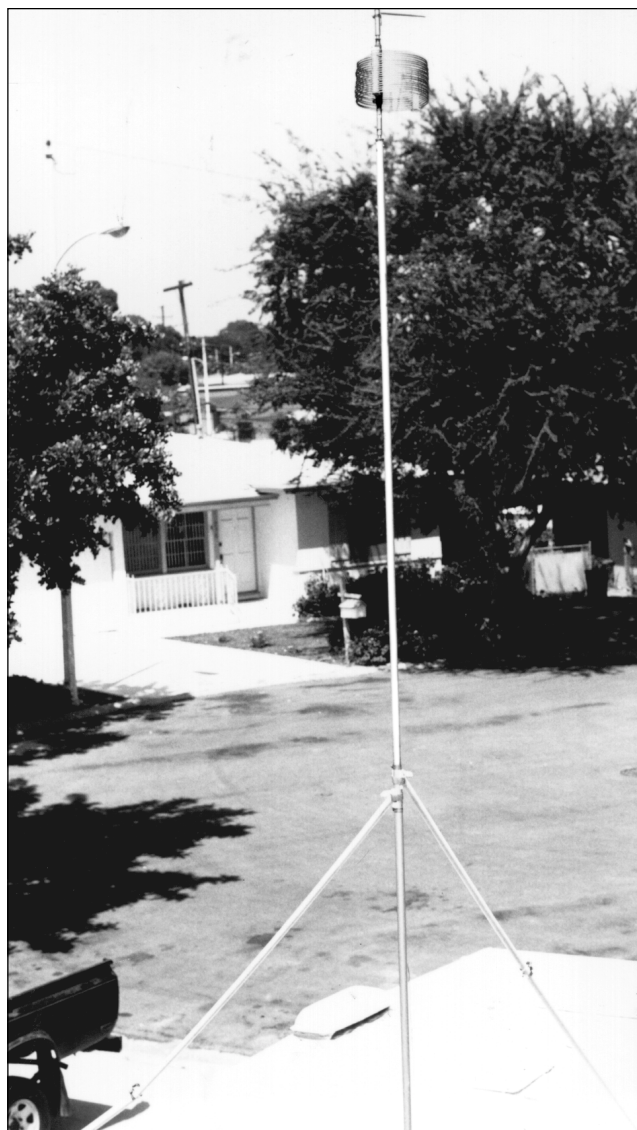
have to climb the roof. Use a non-slip floor mat or something similar to spread the load on the roof and to avoid slipping. Once on the roof, however, the coil is at a height for easy adjustment when the telescoping section is in the down position.

An advantage of being able to assemble the whole antenna on the roof is that you don't need a lot of swing-up room and you can clear trees easily. You can put calibration marks on the upper aluminum section for resonant lengths on the higher bands but just raise the top section up all the way for 80 or 40 meters. Mark also the small coil tuning whip for 80 or 40 meters, although different locations may require slightly different settings due to detuning from nearby metal objects.

The overall length is about 21 feet. The top of the



**Fig 16**—Close-up of one of the snap-on support brackets used to brace the antenna. Note the Velcro pieces used to ensure that the antenna doesn't pop out of the bracket in the wind.



**Fig 17**—Photo showing the two support bracket poles bracing the bottom section of the antenna. The top tuning whip is evident above the homemade loading coil at the top of the bottom section.

author's camper is about 10 feet high when on the truck, putting the tip at 31 feet. This antenna is definitely designed for use when you are parked at a fixed location. N6JF can put up this antenna in less than 5 minutes and can take it down in half the time. The success of this project has as much to do with knowing how and where you operate as it does paying attention to mechanical and electrical details. The antenna has been a good compromise between efficiency and convenience.

## TWO PORTABLE 6-METER ANTENNAS

These antennas were described by Markus Hansen, VE7CA, in *The ARRL Antenna Compendium Vol 5*. After years of HF operation, he became enthusiastic about VHF/UHF operation when he found a used Yaesu FT-726R VHF/UHF all-mode transceiver at a reasonable price.

But he became really enthused when he got on 6 meters and discovered the joys of driving to high mountain peaks to operate. Not only does an antenna have to be portable for this kind of operation, it must be easily assembled and disassembled, just in case you have to move quickly to a better location.

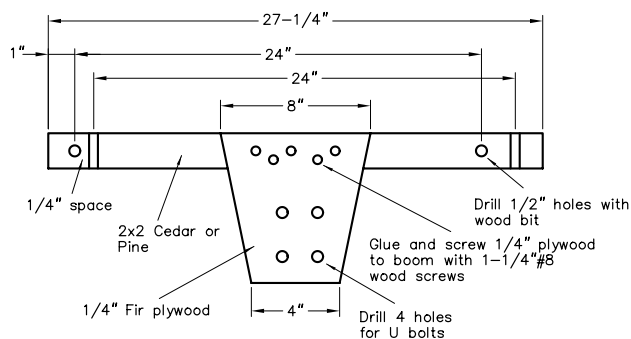
### A Portable Two-Element Six-Meter Quad

VE7CA's primary objective was to construct a two-element quad using material found in any small town. It should not use a complicated matching network. The Gamma matches commonly used on quads do not hold up well when you are setting up and taking down these antennas in the field. The final design adjusted the distance between the driven and the reflector elements so that the intrinsic feed-point impedance was 50 Ω.

**Fig 18** shows the dimensions for the boom and the boom-to-mast bracket. The boom is made from a 27<sup>1</sup>/<sub>4</sub>-inch length of 2 × 2. (The actual dimension of 2 × 2 is closer to 1<sup>3</sup>/<sub>4</sub> by 1<sup>3</sup>/<sub>4</sub> inches but it is commonly known in lumber yards as a 2 × 2.) Use whatever material is available in your area, but lightweight wood is preferred, so clear cedar or pine is ideal. Drill the four 1/2-inch holes for the spreaders with a wood bit, two at each end, through one of the faces of the 2 × 2 and the other through the other face. The boom-to-mast bracket is made from 1/4-inch fir plywood.

The spreaders are 1/2-inch dowel. The local lumberyard had a good supply of fir dowels but other species of wood are available. The exact material is not important. Maple is stronger but expensive. Fiberglass would be ideal but it is not always available locally. Cut two of the 1/2-inch dowels to a length of 83<sup>5</sup>/<sub>8</sub> inches for the driven element spreaders and two to 88 inches for the reflector spreaders. **Fig 19** shows one end of the boom with the two spreaders inserted. The mast was made from two six-foot lengths of 1<sup>3</sup>/<sub>4</sub>-inch fir dowel. Again, use whatever you may have available. Waterproof all wooden parts with at least two coats of exterior varnish.

While you are at the lumberyard or hardware store look for plastic pipe that fits over the end of the 1/2-inch spreaders.

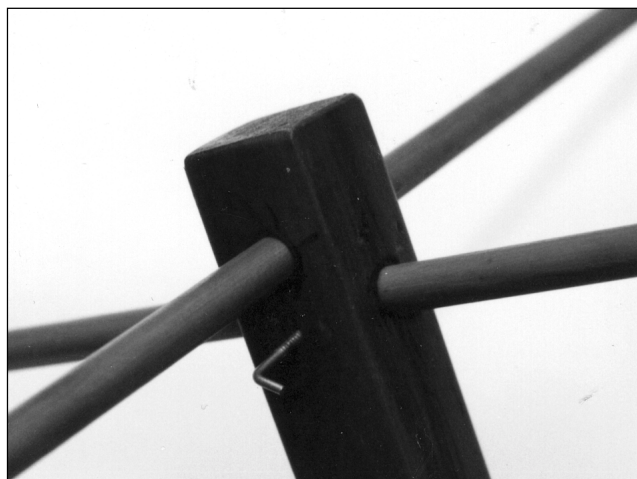


**Fig 18—Dimensions for boom and the boom-to-mast bracket for VE7CA's portable two-element 6-meter quad.**

You will need a one-foot length, with some to spare. Cut it into seven equal lengths, approximately one inch long, and one to a length of 1<sup>1</sup>/<sub>2</sub> inches. Drill a 1/16-inch hole through the seven equal lengths 1/4 inch from the ends, and two holes one above the other 1/4 inch apart on the 1<sup>1</sup>/<sub>2</sub>-inch sleeve. VE7CA used #14 hard-drawn stranded bare copper wire for the elements. Do not use insulated wire unless you are willing to experimentally determine the element lengths, since the insulation detunes each element slightly.

Cut the reflector element 251 inches long and slip one end of the wire through the holes you drilled in four of the plastic sleeves. Don't attempt to secure the wire to the plastic sleeves at this point. Cross the end of the reflector elements one inch from their respective ends and twist and solder together. The total circumference of the reflector element should be 249 inches when the ends are connected together.

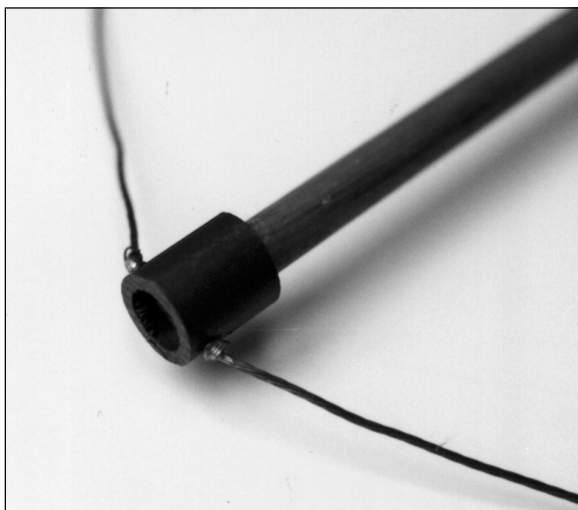
Cut the driven element wire to 241 inches and slip three of the 1-inch sleeves onto the wire. Again, don't secure the wires to the sleeves yet. Then the ends are passed through the two holes in the 1<sup>1</sup>/<sub>2</sub>-inch pipe. Wrap the ends around



**Fig 19—Photo of one end of the VE7CA quad with the two spreaders inserted.**

the pipe and twist them back onto themselves to secure the wire. The coax feed line is attached directly to the two ends at this point. The circumference of the driven-element loop from the points where the coax is attached should be  $236\frac{5}{8}$  inches. Solder the coax feed line to the driven element and waterproof the coax with silicone seal. The author used RG-58, as it is lightweight. The length required for a portable installation is typically not very long, maybe 20 feet, so the loss in the small cable is not excessive. Near the feed point, coil the coax into six turns with an inside diameter of two inches. This is an effective method of choking any RF from flowing on the outside of the coax shield.

Begin assembling the quad by pushing the two reflector spreaders, without wires attached, through one end of the boom and the two shorter driven-element spreaders through the holes in the other end of the boom. Center the spreaders and mark the spreaders with a black felt-tip pen next to the boom. Now insert a  $1\frac{1}{2}$  #8 wood screw or a threaded L-hook into the boom so that it just touches one of the spreaders. Take the screw or L-hook out and file the end flat, then reinsert it so that it is just snug against the spreaders. The author only used two L-hooks for the two vertical spreaders; the horizontal spreaders are held in the proper position by the tension of the wire loops. If you use an L-hook, you can unscrew it with your hands—you won't have



**Fig 20**—Photo showing one of the plastic sleeves slipped over end of a spreader to provide a mechanical mounting point and support for the wires.



**Fig 21**—Photo of the two-element quad's boom, with the plywood boom-to-mast bracket secured with wood screws and glue.

to worry about leaving the screwdriver at home.

You are now ready to assemble the wire loops. Take the reflector loop and place the four plastic caps over the ends of the reflector spreaders. Equalize the wire lengths between the spreader so that the loop is square. Now, secure the plastic sleeve pipes by tightly wrapping wire around the sleeve and the wire element and soldering the wire in place. See **Fig 20**, a photo showing one of the plastic sleeves slipped over one of the spreader ends, with the wire element through the hole and fastened in place. Follow the same procedure with the driven element.

**Fig 21** shows the quad's boom, with the plywood boom-to-mast bracket fastened with wood screws and glue. Two U-bolts are used to attach to the mast. When the quad is raised, the shape of the loop is commonly known as a diamond configuration. The mast consists of two six-foot lengths of doweling joined together with a two-foot length of PVC plastic pipe, held together with wood screws.

Make a slot the width of a #8 wood screw about one inch deep from the top of the plastic PVC pipe and then put the top mast into the plastic pipe. Insert a one inch #8 wood screw into the bottom of the slot you cut into the top of the pipe and tighten only enough so that the top mast can be removed without unscrewing it. VE7CA drove a nail into the end of the lower mast and left it exposed an inch or more. This end is placed in the ground and the nail holds the pole in place. A strip of wood approximately  $1 \times 3$  and long enough to cross over the roof rack of the family van is used to hold the center of the antenna mast to the roof rack of the



**Fig 22**—Ready for action! VE7CA has set up his quad next to the family van.



van with small diameter rope. See **Fig 22** for a photo of the quad in action next to the family van.

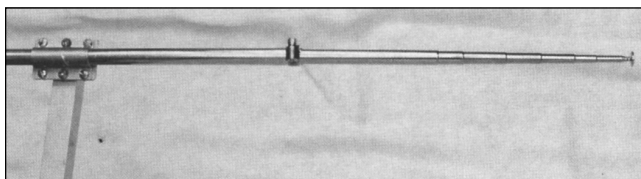
To disassemble the quad, lay it on its side, slip the plastic sleeves off the ends of the spreaders and roll up the wire loops. Loosen the L-hooks holding the vertical spreaders in place. Push the spreaders out of the boom, loosen the U-bolts and free the mast from the boom.

That is all there is to it. It takes about two minutes to put it up, or take it down. It is quite sturdy and has survived several high-wind storms.

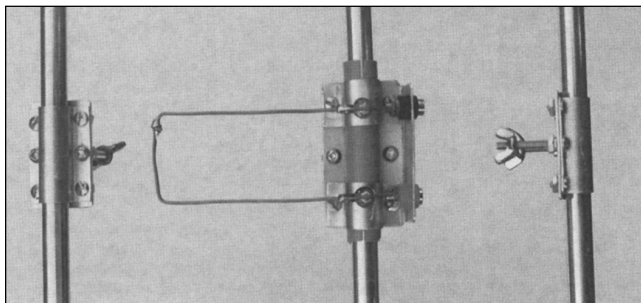
### A Three-Element Portable 6-Meter Yagi

The idea to build a Yagi antenna resulted when the author traded the family van for a compact car. He needed something which would fit into the trunk of the car. At close to 7-feet long, the quad spreaders were too long. Computer modeling showed that a three-element Yagi on a five-foot boom also could pick up about 1.5 dB gain over the short-boom two-element quad. A five-foot boom fits into the trunk or across the back seat of the car, but something had to be done about the nine-foot elements!

One day VE7CA noticed a box of portable-radio telescoping antenna elements at the radio parts store. They were 54 inches long when fully extended. He next found a 60-inch length of aluminum tubing that fit over the end of the telescoping elements. There are many different sizes of telescoping antenna elements, with different diameters. This is where you will have to use your scrounging skills! **Fig 23** shows how the tubing is used as a center section to join two telescoping elements together.



**Fig 23**—Photo showing a piece of aluminum tubing used as a center section to join the two telescoping tips together.



**Fig 24**—A view of the center sections of the three Yagi elements with their mounting brackets.

See **Table 3** for dimensions and element spacings. Each center section is slotted at both ends with a hacksaw, and stainless-steel hose clamps are used to secure the telescoping elements.

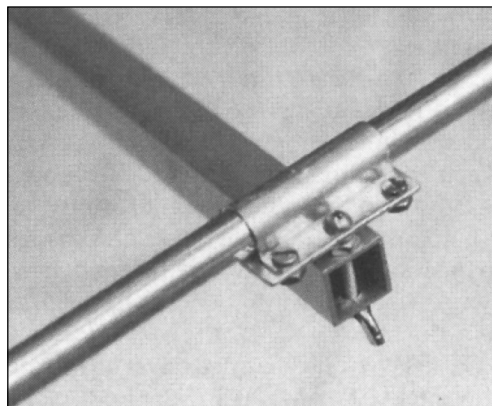
**Fig 24** shows the center sections of the three elements with their mounting brackets. A square boom was used to obtain a flat surface to work with. **Fig 25** shows how the reflector is attached to the end of the boom with two 1½-inch 10-32 bolts and wingnuts. **Fig 26A** provides the dimensions and details for the reflector and director element-to-boom brackets, which are formed from 1/16-inch plate aluminum. The driven element is split in the center and is insulated from the boom. **Fig 26B** shows details for the driven-element bracket. **Fig 27** is a photo of the driven element with the hairpin matching wire and the banana plugs used to connect the coax to the driven element. You could use a female PL-259 connector if you wish. VE7CA used #14 solid bare copper wire for the hairpin. It is very durable—even after being severely warped in the car trunk, it can be bent back into shape quickly and easily.

The boom is ¾-inch square aluminum, 65 inches long. The material was found at a local hardware store. To detach the elements, just loosen the wing nuts and remove the elements from the boom. A similar method was used to attach the support mast to the boom.

**Table 3**  
**Three-Element Yagi, Element Lengths and Spacing Along the Boom, and Hairpin Dimensions**

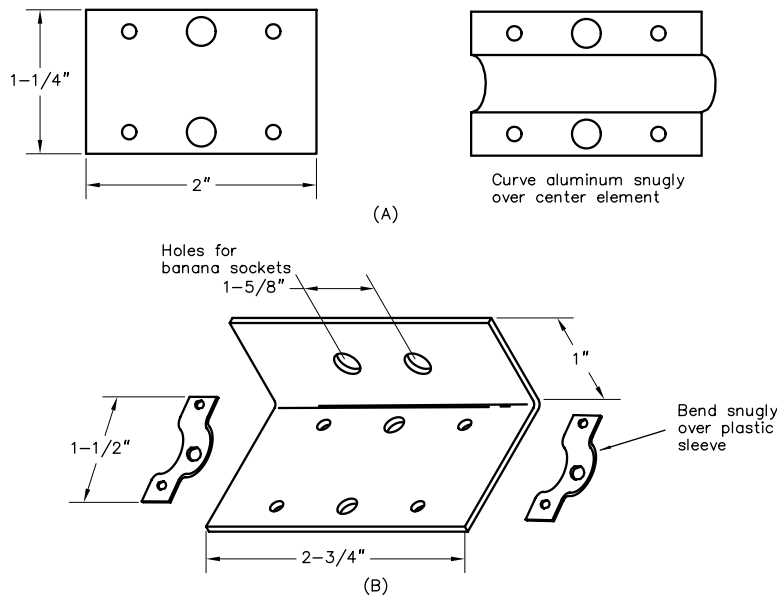
<i>Element Along Boom</i>	<i>Spacing Section Ele. (inches)</i>	<i>Center Length (inches)</i>	<i>Telescoping (inches)</i>	<i>Total Length</i>
Reflector	0	22 <sup>3</sup> / <sub>4</sub>	51 <sup>1</sup> / <sub>2</sub>	125 <sup>3</sup> / <sub>4</sub>
Driven	28	9 <sup>3</sup> / <sub>4</sub> *	48 <sup>5</sup> / <sub>8</sub>	58 <sup>3</sup> / <sub>16</sub>
Director	63 <sup>3</sup> / <sub>8</sub>	14 <sup>1</sup> / <sub>2</sub>	51 <sup>1</sup> / <sub>4</sub>	117
Hairpin	#14 wire	4 long	1 <sup>5</sup> / <sub>8</sub> spacing	

\* driven-element uses 2 sections insulated at center

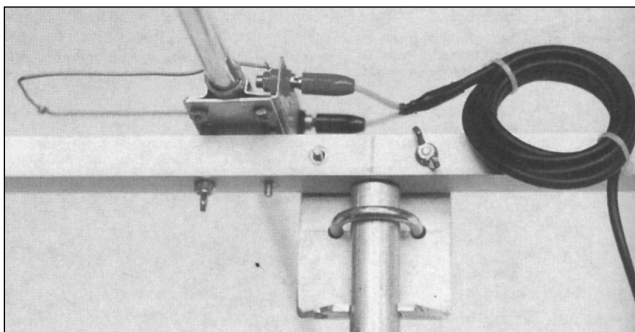


**Fig 25**—Photo detailing attachment of the reflector to the square-section boom, using two #10 bolts and wingnuts.

Drill all hole sizes to suit available hardware



**Fig 26—At A, details for the reflector and director element-to-boom brackets, made of 1/16-inch plate aluminum. At B, details for the driven-element bracket. These are screwed to the square boom.**



**Fig 27—Photo of the driven element, complete with hairpin match and the banana plugs used to connect the coax cable to the driven element.**

As with the quad, a choke balun was used, consisting of a coil of 6 turns of coax with an inside diameter of 2 inches. To tune the hairpin match, assemble the Yagi on its mast and extend the elements. Spray switch contact solution on a cloth and wipe any dirt and grease from the elements. Push the elements together and apart a couple of times so that the contact solution cleans the elements thoroughly. Attach the antenna mast to your vehicle or use whatever method of support you intend to use in the field. Connect an SWR meter

and a transmitter to the coax feeding the antenna. VE7CA used two alligator clips soldered together to slide along the two hairpin wires to find the position for the lowest SWR. The dimensions computed by computer were correct! The SWR was below 1.16:1 from 50.05 to 50.2 MHz.

You can take this antenna out of the trunk of the car and assemble it in less than two minutes. One caution: the telescoping elements when fully extended are quite fragile. VE7CA has not broken one as yet, but carrying a spare element just in case would be a good idea.

## BIBLIOGRAPHY

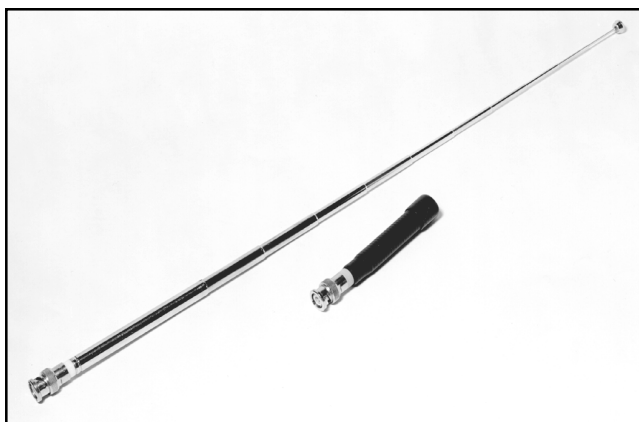
Source material and more extended discussion of topics covered in this chapter can be found in the references given below.

- R. J. Decesari, "A Portable Quad for 2 Meters," *QST*, Oct 1980, and "Portable Quad for 2 Meters, Part 2," Technical Correspondence, *QST*, Jun 1981.
- D. DeMaw, "A Traveling Ham's Trap Vertical," *QST*, Oct 1980.
- J. Hall, "Zip-Cord Antennas—Do They Work?" *QST*, Mar 1979.
- C. L. Hutchinson, "A Tree-Mounted 30-Meter Ground-Plane Antenna," *QST*, Sep 1974.
- C. W. Schecter, "A Deluxe RV 5-Band Antenna," *QST*, Oct 1980.

# Mobile and Maritime Antennas

Mobile antennas are those designed for use while they are in motion. At the mention of mobile antennas, most amateurs think of a whip mounted on an automobile or other highway vehicle, perhaps on a recreational vehicle (RV) or maybe on an off-road vehicle. While it is true that most mobile antennas are vertical whips, mobile antennas can also be found in other places. For example, antennas mounted aboard a boat or ship are mobile, and are usually called *maritime antennas*. **Fig 1** shows yet another type of mobile antenna—those for use on handheld transceivers. Because they may be used while in motion, even these antennas are mobile by literal definition.

Pictured in Fig 1 is a telescoping full-size quarter-wave antenna for 144 MHz, and beside it a *stubby* antenna for the same band. The stubby is a helically wound radiator, made of stiff copper wire enclosed in a protective covering of rubber-like material. The inductance of the helical windings provides electrical loading for the antenna. For frequencies above 28 MHz, most mobile installations permit the use of



**Fig 1**—Two mobile antennas—mobile because they may be used while in motion. Shown here are a telescoping  $\frac{1}{4}\lambda$  antenna and a “stubby” antenna, both designed for use at 144 MHz. The  $\frac{1}{4}\lambda$  antenna is 19 inch long, while the stubby antenna is only  $3\frac{1}{2}$  inch long. (Both dimensions exclude the length of the BNC connectors. The stubby is a helically wound radiator.

a full-size antenna, but sometimes smaller, loaded antennas are used for convenience. The stubby, for example, is convenient for short-range communications, avoiding the problems of a lengthier, cumbersome antenna attached to a handheld radio.

Below 28 MHz, physical size becomes a problem with full-size whips, and some form of electrical loading (as with the stubby) is usually employed. Commonly used loading techniques are to place a coil at the base of the whip (base loading), or at the center of the whip (center loading). These and other techniques are discussed in this chapter.

Few amateurs construct their own antennas for HF mobile and maritime use, since safety reasons dictate very sound mechanical construction. Several construction projects are included, however, in this chapter for those who may wish to build their own mobile antenna. Even if commercially made antennas are installed, most require some adjustment for the particular installation and type of operation desired and the information given here may provide a better understanding of the optimization requirements.

## HF-MOBILE FUNDAMENTALS

**Fig 2** shows a typical bumper-mounted center-loaded whip suitable for operation in the HF range. Jack Schuster, W1WEF, operates 80 through 2 meters from his car. The antenna could also be mounted on the car body itself (such as a fender), and mounts are available for this purpose. The base spring and tennis ball act as shock absorbers for the bottom of the whip, as the continual flexing while in motion would otherwise weaken the antenna. A short heavy mast section is mounted between the base spring and loading coil. Some models have a mechanism that allows the antenna to be tipped over for adjustment or for fastening to the roof of the car when not in use.

It is also advisable to extend a couple of guy lines from the base of the loading coil to clips or hooks fastened to the roof gutter on the car, or to the trunk and rear bumper, as W1WEF has done. Nylon fishing line (about 40-pound test) is suitable for this purpose. The guy lines act as safety cords and also reduce the swaying motion of the antenna considerably. The feed line to the transmitter is connected



**Fig 2—A typical bumper-mounted HF mobile antenna, as used by W1WEF. Note the nylon guy lines and the tennis ball used as a shock absorber. (Photo courtesy W1WEF.)**

to the bumper and base of the antenna. Good low-resistance connections are important here.

Tune-up of the antenna is usually accomplished by changing the height of the adjustable whip section above the precut loading coil. First, tune the receiver and try to determine where the signals seem to peak up. Once this frequency is found, check the SWR with the transmitter on, and find the frequency where the SWR is lowest. Shortening the adjustable section will increase the resonant frequency, and making it longer will lower the frequency. It is important that the antenna be away from surrounding objects such as overhead wires by ten feet or more, as considerable detuning can occur. Once the setting is found where the SWR is lowest at the center of the desired frequency range, the length of the adjustable section should be recorded.

Propagation conditions and ignition noise are usually the limiting factors for mobile operation on 10 through 28 MHz. Antenna size restrictions affect operation somewhat on 7 MHz and much more on 3.5 and 1.8 MHz. From this standpoint, perhaps the optimum band for HF-mobile operation is 7 MHz. The popularity of the regional mobile nets on 7 MHz is perhaps the best indication of its suitability. For local work, 28 MHz is also useful, as antenna efficiency is high and relatively simple antennas without loading coils are easy to build.

As the frequency of operation is lowered, an antenna of fixed length looks (at its feed point) like a decreasing resistance in series with an increasing capacitive reactance. The capacitive reactance must be tuned out, necessitating the use of an equivalent series inductive reactance or loading coil. The amount of inductance required will be determined by the placement of the coil in the antenna system.

Base loading requires the lowest value of inductance for a fixed-length antenna, and as the coil is placed farther up the whip, the necessary value increases. This is because the capacitance of the shorter antenna section (above the coil) to the car body is now lower (higher capacitive reactance), requiring more inductance to tune the antenna to resonance. The advantage is that the current distribution on the whip is improved, increasing the radiation resistance. The disadvantage is that requirement of a larger coil also means the coil size and losses increase. Center loading has been generally accepted as a good compromise with minimal construction problems. Placing the coil  $\frac{2}{3}$  the distance up the whip seems to be about the optimum position.

For typical antenna lengths used in mobile work, the difficulty in constructing suitable loading coils increases as the frequency of operation is lowered. Since the required resonating inductance gets larger and the radiation resistance decreases at lower frequencies, most of the power is dissipated in the coil's loss resistance and in other ohmic losses. This is one reason why it is advisable to buy a commercially made loading coil with the highest power rating possible, even if only low-power operation is planned.

Coil losses in the higher-power loading coils are usually less (percentage-wise), with subsequent improvement in radiation efficiency, regardless of the power level used. Of course, the above philosophy also applies to homemade loading coils, and design considerations will be considered in a later section.

Once the antenna is tuned to resonance, the input impedance at the antenna terminals will look like a pure resistance. Neglecting losses, this value drops from nearly  $15 \Omega$  at 21 MHz to  $0.1 \Omega$  at 1.8 MHz for an 8-foot whip. When coil and other losses are included, the input resistance increases to approximately  $20 \Omega$  at 1.8 MHz and  $16 \Omega$  at 21 MHz. These values are for relatively high-efficiency systems. From this it can be seen that the radiation efficiency is much poorer at 1.8 MHz than at 21 MHz under typical conditions.

Since most modern gear is designed to operate with a  $50\text{-}\Omega$  transmission line, a matching network is usually necessary, especially with the high-efficiency antennas previously mentioned. This can take the form of either a broadband transformer, a tapped coil, or an LC matching network. With homemade or modified designs, the tapped-coil arrangement is perhaps the easiest one to build, while the broadband transformer requires no adjustment. As the losses go up, so does the input resistance, and in less efficient systems the matching network may not be needed.

### **The Equivalent Circuit of a Typical Mobile Antenna**

In the previous section, some of the general considerations were discussed, and these will now be taken up in more detail. It is customary in solving problems involving electric and magnetic fields (such as antenna systems) to try to find an equivalent network with which to

replace the antenna for analysis reasons. In many cases, the network may be an accurate representation over only a limited frequency range. However, this is often a valuable method in matching the antenna to the transmission line.

Antenna resonance is defined as the frequency at which the input impedance at the antenna terminals is purely resistive. The shortest length at which this occurs for a vertical antenna over a ground plane is when the antenna is an electrical quarter wavelength at the operating frequency; the impedance value for this length (neglecting losses) is about 36 Ω. The idea of resonance can be extended to antennas shorter (or longer) than a quarter wave, and means only that the input impedance is purely resistive. As pointed out previously, when the frequency is lowered, the antenna looks like a series RC circuit, as shown in **Fig 3**. For the average 8-foot whip, the capacitive reactance of  $C_A$  may range from about -150 Ω at 21 MHz to as high as -8000 Ω at 1.8 MHz, while the radiation resistance  $R_R$  varies from about 15 Ω at 21 MHz to as low as 0.1 Ω at 1.8 MHz.

For an antenna less than  $0.1 \lambda$  long, the approximate radiation resistance may be determined from the following:

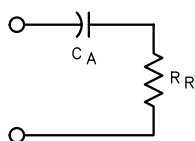
$$R_R = 273 \times (\ell f)^2 \times 10^{-8} \quad (\text{Eq 1})$$

where  $\ell$  is the length of the whip in inches, and  $f$  is the frequency in megahertz.

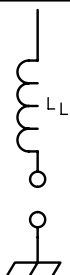
Since the resistance is low, considerable current must flow in the circuit if any appreciable power is to be dissipated in the form of radiation in  $R_R$ . Yet it is apparent that little current can be made to flow in the circuit as long as the comparatively high series reactance remains.

### Antenna Capacitance

Capacitive reactance can be canceled by connecting an equivalent inductive reactance, (coil  $L_L$ ) in series, as shown in **Fig 4**, thus tuning the system to resonance.



**Fig 3**—At frequencies below resonance, the whip antenna will show capacitive reactance as well as resistance.  $R_R$  is the radiation resistance, and  $C_A$  represents the antenna capacitance.



**Fig 4**—The capacitive reactance at frequencies below the resonant frequency of the whip can be canceled by adding an equivalent inductive reactance in the form of a loading coil in series with the antenna.

The capacitance of a vertical antenna shorter than a quarter wavelength is given by:

$$C_A = \frac{17 \ell}{\left[ \left( \ln \frac{24 \ell}{D} \right) - 1 \right] \left[ 1 - \left( \frac{f \ell}{234} \right)^2 \right]} \quad (\text{Eq 2})$$

where

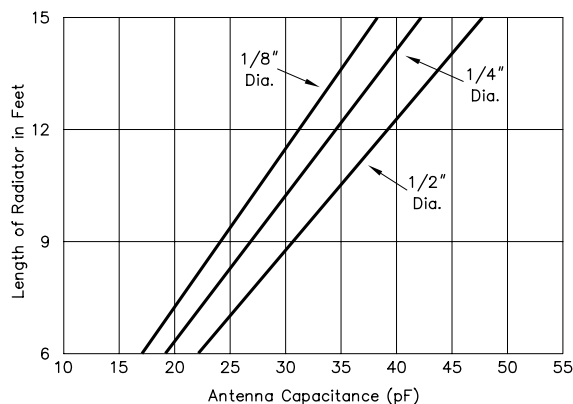
- $C_A$  = capacitance of antenna in pF
- $\ell$  = antenna height in feet
- $D$  = diameter of radiator in inches
- $f$  = operating frequency in MHz

$$\ln \frac{24 \ell}{D} = 2.3 \log_{10} \frac{24 \ell}{D}$$

**Fig 5** shows the approximate capacitance of whip antennas of various average diameters and lengths. For 1.8, 4 and 7 MHz, the loading coil inductance required (when the loading coil is at the base) would be approximately the inductance required to resonate in the desired band (with the whip capacitance taken from the graph). For 10 through 21 MHz, this rough calculation will give more than the required inductance, but it will serve as a starting point for the final experimental adjustment that must always be made.

### LOADING COIL DESIGN

To minimize loading coil loss, the coil should have a high ratio of reactance-to-resistance (that is, a high unloaded Q). A 4-MHz loading coil wound with small wire on a small-diameter solid form of poor quality, and enclosed in a metal protector, may have a Q as low as 50, with a loss resistance of 50 Ω or more. High-Q coils require a large conductor, air-wound construction, large spacing between turns, and the best insulating material available. A diameter not less than half the length of the coil (not always mechanically



**Fig 5**—Graph showing the approximate capacitance of short vertical antennas for various diameters and lengths. These values should be approximately halved for a center-loaded antenna.

feasible) and a minimum of metal in the field of the coil are also necessities for optimum efficiency. Such a coil for 4 MHz may show a Q of 300 or more, with a resistance of 12 Ω or less.

The coil could then be placed in series with the feed line at the base of the antenna to tune out the unwanted capacitive reactance, as shown in Fig 4. Such a method is often referred to as *base-loading*, and many practical mobile antenna systems have been built using this scheme.

Over the years, the question has come up as to whether or not more efficient designs are possible compared with simple base loading. While many ideas have been tried with varying degrees of success, only a few have been generally accepted and incorporated into actual systems. These are center loading, continuous loading, and combinations of the latter with more conventional antennas.

### Base Loading and Center Loading

If a whip antenna is short compared to a wavelength and the current is uniform along the length  $\ell$ , the electric field strength E, at a distance d, away from the antenna is approximately:

$$E = \frac{120\pi I f}{D\lambda} \quad (\text{Eq 3})$$

where

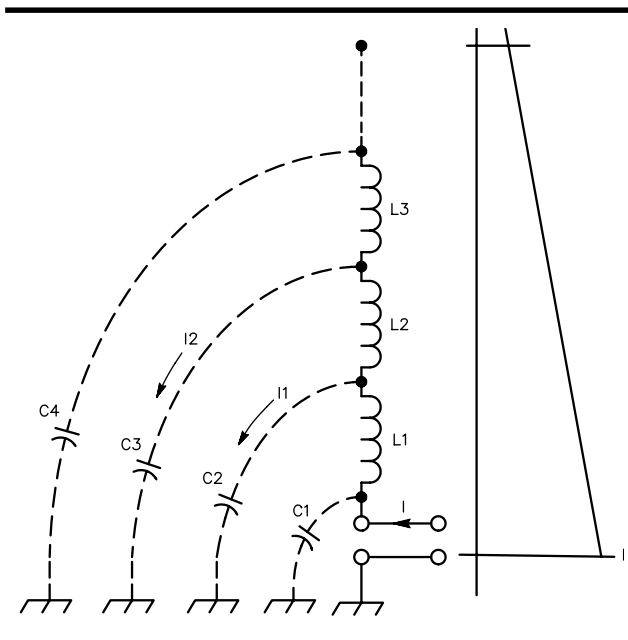
I is the antenna current in amperes

$\lambda$  is the wavelength in the same units as D and  $\ell$ .

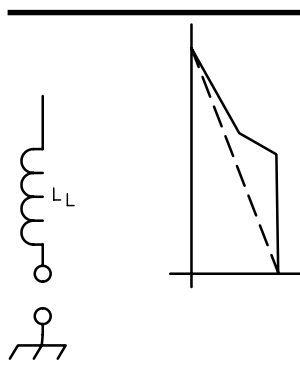
A uniform current flowing along the length of the whip is an idealized situation, however, since the current is greatest at the base of the antenna and goes to a minimum at the top. In practice, the field strength will be less than that given by the above equation, because it is a function of the current distribution on the whip.

The reason that the current is not uniform on a whip antenna can be seen from the circuit approximation shown in Fig 6. A whip antenna over a ground plane is similar in many respects to a tapered coaxial cable where the center conductor remains the same diameter along its length, but with an increasing diameter outer conductor. The inductance per unit length of such a cable would increase along the line, while the capacitance per unit length would decrease. In Fig 6 the antenna is represented by a series of LC circuits in which C1 is greater than C2, which is greater than C3, and so on. L1 is less than L2, which is less than succeeding inductances. The net result is that most of the antenna current returns to ground near the base of the antenna, and very little near the top.

Two things can be done to improve this distribution and make the current more uniform. One would be to increase the capacitance of the top of the antenna to ground through the use of top loading or a capacitance hat, as discussed in Chapter 6. Unfortunately, the wind resistance of the hat makes it somewhat unwieldy for mobile use. The other method is to place the loading coil farther up the whip, as shown in Fig 7, rather than at the base. If the coil is



**Fig 6—A circuit approximation of a simple whip over a perfectly conducting ground plane. The shunt capacitance per unit length gets smaller as the height increases, and the series inductance per unit length gets larger. Consequently, most of the antenna current returns to the ground plane near the base of the antenna, giving the current distribution shown at the right.**



**Fig 7—Improved current distribution resulting from center loading.**

resonant (or nearly so) with the capacitance to ground of the section above the coil, the current distribution is improved as also shown in Fig 7. The result with both top loading and center loading is that the radiation resistance is increased, offsetting the effect of losses and making matching easier.

Table 1 shows the approximate loading coil inductance for the various amateur bands. Also shown in the table are approximate values of radiation resistance to be expected with an 8-foot whip, and the resistances of loading coils—one group having a Q of 50, the other a Q of 300. A comparison of radiation and coil resistances will show the importance of reducing the coil resistance to a minimum, especially on the three lower frequency bands. Table 2 shows suggested loading-coil dimensions for the inductance values given in Table 1.

**Table 1**  
**Approximate Values for 8-ft Mobile Whip**

<i>f</i> (MHz)	Loading <i>L</i> μH	<i>R<sub>C</sub></i> (Q50) Ω	<i>R<sub>C</sub></i> (Q300) Ω	<i>R<sub>R</sub></i> Ω	Feed <i>R</i> * Ω	Matching <i>L</i> μH
<b>Base Loading</b>						
1.8	345	77	13	0.1	23	3
3.8	77	37	6.1	0.35	16	1.2
7.2	20	18	3	1.35	15	0.6
10.1	9.5	12	2	2.8	12	0.4
14.2	4.5	7.7	1.3	5.7	12	0.28
18.1	3.0	5.0	1.0	10.0	14	0.28
21.25	1.25	3.4	0.5	14.8	16	0.28
24.9	0.9	2.6	—	20.0	22	0.25
29.0	—	—	—	—	36	0.23
<b>Center Loading</b>						
1.8	700	158	23	0.2	34	3.7
3.8	150	72	12	0.8	22	1.4
7.2	40	36	6	3.0	19	0.7
10.1	20	22	4.2	5.8	18	0.5
14.2	8.6	15	2.5	11.0	19	0.35
18.1	4.4	9.2	1.5	19.0	22	0.31
21.25	2.5	6.6	1.1	27.0	29	0.29

*R<sub>C</sub>* = loading coil resistance; *R<sub>R</sub>* = radiation resistance.

\*Assuming loading coil Q = 300, and including estimated ground-loss resistance.

**Table 2**  
**Suggested Loading Coil Dimensions**

<i>Req'd</i> <i>L</i> (μH)	<i>Turns</i>	<i>Wire</i> <i>Size</i>	<i>Dia.</i> <i>Inches</i>	<i>Length</i> <i>Inches</i>
700	190	22	3	10
345	135	18	3	10
150	100	16	2½	10
77	75	14	2½	10
77	29	12	5	4¼
40	28	16	2½	2
40	34	12	2½	4¼
20	17	16	2½	1¼
20	22	12	2½	2¾
8.6	16	14	2	2
8.6	15	12	2½	3
4.5	10	14	2	1¼
4.5	12	12	2½	4
2.5	8	12	2	2
2.5	8	6	2¾	4½
1.25	6	12	1¾	2
1.25	6	6	2¾	4½

### OPTIMUM DESIGN OF SHORT COIL-LOADED HF MOBILE ANTENNAS

Optimum design of short HF mobile antennas results from a careful balance of the appropriate loading coil Q-factor, loading coil position in the antenna, ground loss resistance, and the length-to-diameter ratio of the antenna. The optimum balance of these parameters can be realized only through a thorough understanding of how they interact.

This section presents a mathematical approach to designing mobile antennas for maximum radiation efficiency. Bruce Brown, W6TWW, in *The ARRL Antenna Compendium Volume 1*, first presented this approach. (See the Bibliography at the end of this chapter.)

The optimum location for a loading coil in an antenna can be found experimentally, but it requires many hours of designing and constructing models and making measurements to ensure the validity of the design. A faster and more reliable way of determining optimum coil location is through the use of a personal computer. This approach allows the variation of any single variable, while observing the cumulative effects on the system. When plotted graphically, the data reveals that the placement of the loading coil is critical if maximum radiation efficiency is to be realized. (See the program *MOBILE.EXE*, which is included on the CD-ROM in the back of this book.)

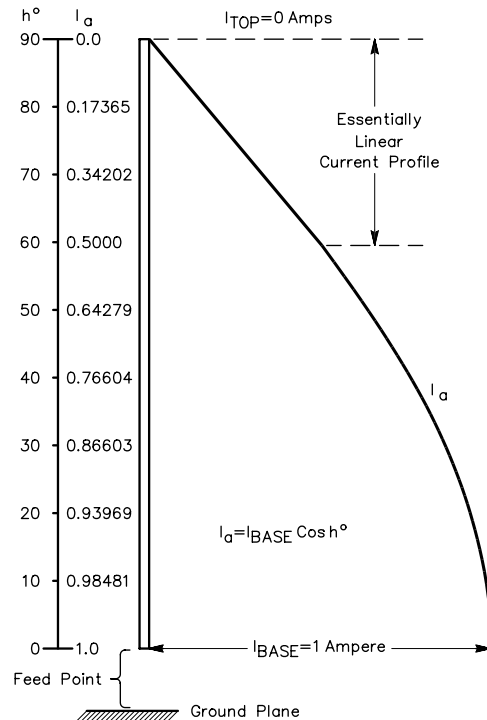
### Radiation Resistance

The determination of radiation efficiency requires the knowledge of resistive power losses and radiation losses. Radiation loss is expressed in terms of radiation resistance. Radiation resistance is defined as the resistance that would dissipate the same amount of power that is radiated by the antenna. The variables used in the equations that follow are defined once in the text, and are summarized in **Table 3**. Radiation resistance of vertical antennas shorter than 45 electrical degrees (1/8 wavelength) is approximately:

$$R_R = \frac{h^2}{312} \quad (\text{Eq 4})$$

**Table 3**  
**Variables used in Eqs 4 through 20**

A = area in degree-amperes  
a = antenna radius in English or metric units  
dB = signal loss in decibels  
E = efficiency in percent  
f (MHz) = frequency in megahertz  
H = height in English or metric units  
h = height in electrical degrees  
h<sub>1</sub> = height of base section in electrical degrees  
h<sub>2</sub> = height of top section in electrical degrees  
I = I<sub>base</sub> = 1 ampere base current  
k = 0.0128  
k<sub>m</sub> = mean characteristic impedance  
k<sub>m1</sub> = mean characteristic impedance of base section  
k<sub>m2</sub> = mean characteristic impedance of top section  
L = length or height of the antenna in feet  
P<sub>1</sub> = power fed to the antenna  
P<sub>R</sub> = power radiated  
Q = coil figure of merit  
R<sub>C</sub> = coil loss resistance in Ω  
R<sub>G</sub> = ground loss resistance in Ω  
R<sub>R</sub> = radiation resistance in Ω  
X<sub>L</sub> = loading-coil inductive reactance



**Fig 8—Relative current distribution on a vertical antenna of height h = 90 electrical degrees.**

where

R<sub>R</sub> = radiation resistance in Ω  
h = antenna length in electrical degrees.

Antenna height in electrical degrees is expressed by:

$$h = \frac{\ell}{984} \times f(\text{MHz}) \times 360 \quad (\text{Eq 5})$$

where

ℓ = antenna length in feet  
f (MHz) = operating frequency in megahertz.

*End effect* is purposely omitted to ensure that an antenna is electrically long. This is so that resonance at the design frequency can be obtained easily by removing a turn or two from the loading coil.

Eq 4 is valid only for antennas having a sinusoidal current distribution and no reactive loading. However, it can be used as a starting point for deriving an equation that is useful for shortened antennas with other than sinusoidal current distributions.

Refer to **Fig 8**. The current distribution on an antenna 90° long electrically (1/4 wavelength) varies with the cosine of the length in electrical degrees. The current distribution of the top 30° of the antenna is essentially linear. It is this linearity that allows for derivation of a simpler, more useful equation for radiation resistance.

The radiation resistance of an electrically short base-loaded vertical antenna can be conveniently defined in terms

of a geometric figure, a triangle, as shown in **Fig 9**. The radiation resistance is given by:

$$R_R = KA^2 \quad (\text{Eq 6})$$

where

K is a constant (to be derived shortly)  
A = area of the triangular current distribution in degree-amperes.

Degree-ampere area is expressed by

$$A = \frac{1}{2} h \times I_{\text{base}} \quad (\text{Eq 7})$$

By combining Eqs 4 and 6 and solving for K, we get

$$K = \frac{h^2}{312 \times A^2} \quad (\text{Eq 8})$$

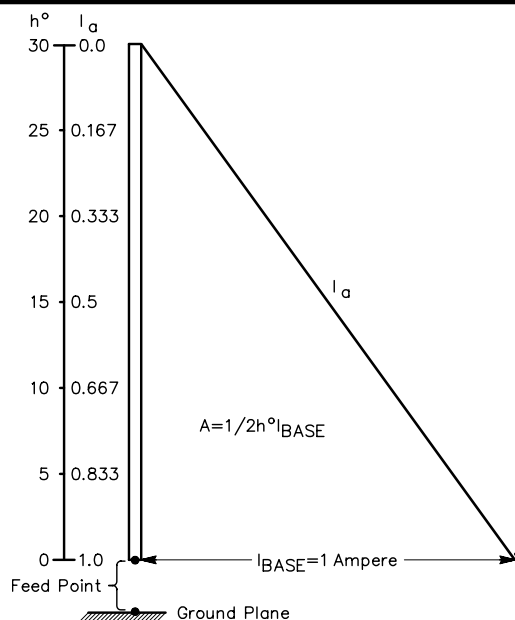
By substituting the values from **Fig 9** into Eq 8 we get

$$K = \frac{30^2}{312 \times (0.5 \times 30 \times 1)^2} = 0.0128$$

and by substituting the derived value of K into Eq 6 we get  
R<sub>R</sub> = 0.0128 × A<sup>2</sup> (Eq 9)

Eq 9 is useful for determining the radiation resistance of coil-loaded vertical antennas less than 30° in length. The derived constant differs slightly from that presented by





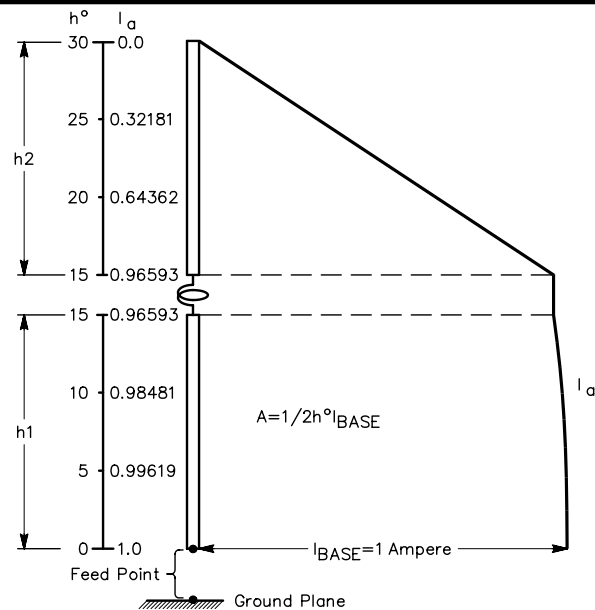
**Fig 9—Relative current distribution on a base-loaded vertical antenna of height  $H = 30$  electrical degrees (linearized). The base loading coil is not shown here.**

Laport (see Bibliography), as he used a different equation for radiation resistance Eq 4.

When the loading coil is moved up an antenna (away from the feed point), the current distribution is modified as shown in Fig 10. The current varies with the cosine of the height in electrical degrees at any point in the base section. Therefore, the current flowing into the bottom of the loading coil is less than the current flowing at the base of the antenna.

But what about the current in the top section of the antenna? The loading coil acts as the lumped constant that it is, and disregarding losses and coil radiation, maintains the same current flow throughout. As a result, the current at the top of a high-Q coil is essentially the same as that at the bottom of the coil. This is easily verified by installing RF ammeters immediately above and below the loading coil in a test antenna. Thus, the coil “forces” much more current into the top section than would flow in the equivalent section of a full 90° long antenna. This occurs as a result of the extremely high voltage that appears at the top of the loading coil. This higher current flow results in more radiation than would occur from the equivalent section of a quarter-wave antenna. (This is true for conventional coils. However, radiation from long thin coils allows coil current to decrease, as in helically wound antennas.)

The cross-hatched area in Fig 10 shows the current that would flow in the equivalent part of a 90° high antenna, and reveals that the degree-ampere area of the whip section of the short antenna is greatly increased as a result of the modified current distribution. The current flow in the top section decreases almost linearly to zero at the top. This can



**Fig 10—Relative current distribution on a center-loaded antenna with base and top sections each equal to 15 electrical degrees in length. The cross-hatched area shows the current distribution that would exist in the top 15° of a 90°-high vertical fed with 1 ampere at the base.**

be seen in Fig 10.

The degree-ampere area of Fig 10 is the sum of the triangular area represented by the current distribution in the top section, and the nearly trapezoidal current distribution in the base section. Radiation from the coil is not included in the degree-ampere area because it is small and difficult to define. Any radiation from the coil can be considered a bonus.

The degree-ampere area is expressed by:

$$A = \frac{1}{2} \left[ h_1 (1 + \cosh h_1) + h_2 (\cosh h_1) \right] \quad (\text{Eq 10})$$

where

- $h_1$  = electrical length in degrees of the base section
- $h_2$  = electrical height in degrees of the top section.

The degree-ampere area (calculated by substituting Eq 10 into Eq 9) can be used to determine the radiation resistance when the loading coil is at any position other than the base of the antenna. Radiation resistance has been calculated with these equations and plotted against loading coil position at three different frequencies for 8- and 11-foot antennas, Fig 11. Eight feet is a typical length for commercial antennas, and 11-foot antennas are about the maximum practical length that can be installed on a vehicle.

In Fig 11, the curves reveal that the radiation resistance rises almost linearly as the loading coil is moved up the antenna. They also show that the radiation resistance rises rapidly as the frequency is increased. If the analysis were stopped at this point, one might conclude that the loading

coil should be placed at the top of the antenna. This is not so, and will become apparent shortly.

### Required Loading Inductance

Calculation of the loading coil inductance needed to resonate a short antenna can be done easily and accurately by using the antenna transmission-line analog described by Boyer in *Ham Radio*. For a base-loaded antenna, Fig 9, the loading coil reactance required to resonate the antenna is given by

$$X_L = -j K_m \cot h \quad (\text{Eq 11})$$

where

$X_L$  = inductive reactance required

$K_m$  = mean characteristic impedance (defined in Eq 12).

The  $-j$  term indicates that the antenna presents capacitive reactance at the feed point. A loading coil must cancel this reactance.

The mean characteristic impedance of an antenna is expressed by

$$K_m = 60 \left[ \left( \ln \frac{2H}{a} \right) - 1 \right] \quad (\text{Eq 12})$$

where

$H$  = physical antenna height (excluding the length of the loading coil)

$a$  = radius of the antenna in the same units as  $H$ .

From Eq 12 you can see that decreasing the height-to-diameter ratio of an antenna by increasing the radius results in a decrease in  $K_m$ . With reference to Eq 11, a decrease in  $K_m$  decreases the inductive reactance required to resonate an antenna. As will be shown later, this will increase radiation efficiency. In mobile applications, we quickly run into wind-loading problems if we attempt to use an antenna that is physically large in diameter.

If the loading coil is moved away from the base of the antenna, the antenna is divided into a base and top section, as depicted in Fig 10. The loading coil reactance required to resonate the antenna when the coil is away from the base is given by

$$X_L = j K_{m2} (\cot h_2) - j K_{m1} (\tan h_1) \quad (\text{Eq 13})$$

In mobile-antenna design and construction, the top section is usually a whip with a much smaller diameter than the base section. Because of this, it is necessary to compute separate values of  $K_m$  for the top and base sections.  $K_{m1}$  and  $K_{m2}$  are the mean characteristic impedances of the base and top sections, respectively.

Loading coil reactance curves for the 3.8-MHz antennas of Fig 11 have been calculated and plotted in Fig 12. These curves show the influence of the loading coil position on the reactance required for resonance. The curves in Fig 12 show that the required reactance decreases with longer antennas. The curves also reveal that the required loading coil reactance grows at an increasingly rapid rate after the coil passes the center of the antenna. Because the highest possible loading coil Q factor is needed, and because optimum Q is attained when the loading coil diameter is twice the loading coil length, the coil would grow like a smoke ring above the center of the antenna, and would quickly reach an impractical size. It is for this reason that the highest loading coil position is limited to one foot from the top of the antenna in all computations.

### Loading Coil Resistance

Loading coil resistance constitutes one of the losses that consumes power that could otherwise be radiated by the antenna. Heat loss in the loading coil is not of any benefit, so it should be minimized by using the highest possible loading coil Q. Loading coil loss resistance is a function of the coil Q and is given by

$$R_C = \frac{X_L}{Q} \quad (\text{Eq 14})$$

where

$R_C$  = loading coil loss resistance in  $\Omega$

$X_L^C$  = loading coil reactance

$Q$  = coil figure of merit

Inspection of Eq 14 reveals that, for a given value of

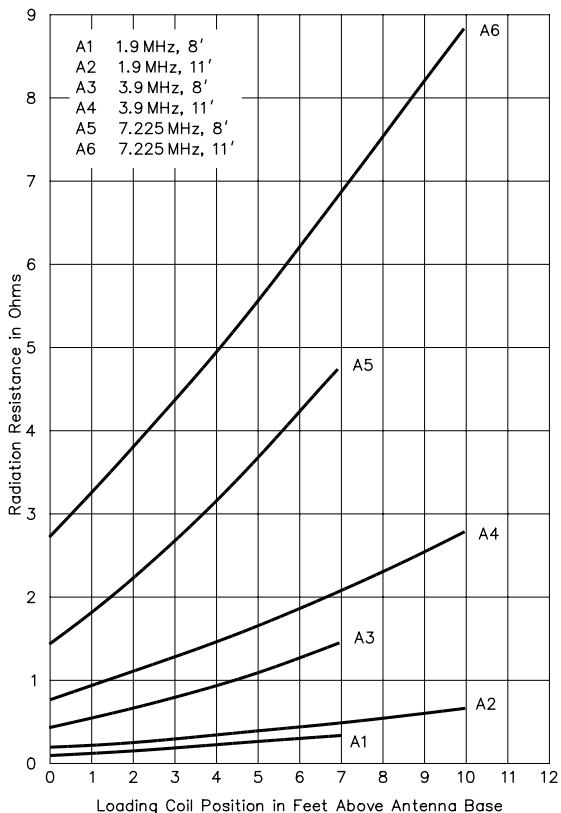
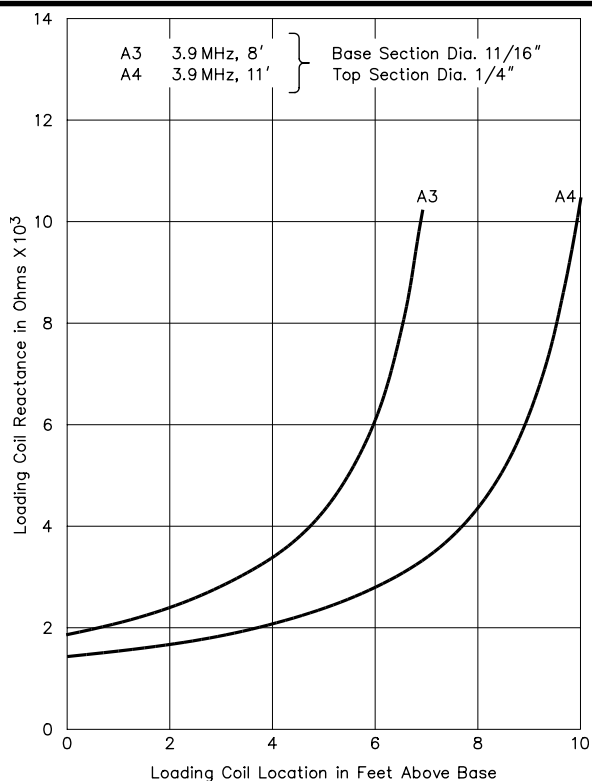


Fig 11—Radiation resistance plotted as a function of loading coil position.



**Fig 12—Loading coil reactance required for resonance, plotted as a function of coil height above the antenna base. The resonant frequency is 3.9 MHz.**

inductive reactance, loss resistance will be lower for higher Q coils. Measurements made with a Q meter show that typical, commercially manufactured coil stock produces a Q between 150 and 160 in the 3.8-MHz band.

Higher Q values can be obtained by using larger diameter coils having a diameter-to-length ratio of two, by using larger diameter wire, by using more spacing between turns, and by using low-loss polystyrene supporting and enclosure materials. In theory, loading coil turns should not be shorted for tuning purposes because shorted turns somewhat degrade Q. Pruning to resonance should be done by removing turns from the coil.

In fairness, it should be pointed out that many practical mobile antennas use large-diameter loading coils with shorted turns to achieve resonance. The popular “Texas Bug Catcher” coils come to mind here. Despite general proscriptions against shorting turns, these systems are often more efficient than antennas with small, relatively low-Q, fixed loading coils.

### Radiation Efficiency

The ratio of power radiated to power fed to an antenna determines the radiation efficiency. It is given by:

$$E = \frac{P_R}{P_I} \times 100\% \quad (\text{Eq 15})$$

where

- E = radiation efficiency in percent
- $P_R$  = power radiated
- $P_I$  = power fed to the antenna at the feed point.

In a short, coil-loaded mobile antenna, a large portion of the power fed to the antenna is dissipated in ground and coil resistances. A relatively insignificant amount of power is also dissipated in the antenna conductor resistance and in the leakage resistance of the base insulator. Because these last two losses are both very small and difficult to estimate, they are here neglected in calculating radiation efficiency.

Another loss worth noting is matching network loss. Because we are concerned only with power fed to the antenna in the determination of radiation efficiency, matching network loss is not considered in any of the equations. Suffice it to say that matching networks should be designed for minimum loss in order to maximize the transmitter power available at the antenna.

The radiation efficiency equation may be rewritten and expanded as follows:

$$E = \frac{I^2 R_R \times 100}{I^2 R_R + I^2 R_G + (I \cosh h_1)^2 R_C} \quad (\text{Eq 16})$$

where

- I = antenna base current in amperes
- $R_G$  = ground loss resistance in  $\Omega$
- $R_C$  = coil loss resistance in  $\Omega$ .

Each term of Eq 16 represents the power dissipated in its associated resistance. All the current terms cancel, simplifying this equation to

$$E = \frac{R_R \times 100}{R_R + R_G + R_C (\cos^2 h_1)} \quad (\text{Eq 17})$$

For base-loaded antennas the term  $\cos^2 h_1$  drops to unity and may be omitted.

### Ground Loss

Eq 14 shows that the total resistive losses in the antenna system are:

$$R_T = R_R + R_G + R_C (\cos^2 h_1) \quad (\text{Eq 18})$$

where  $R_T$  is the total resistive loss. Ground loss resistance can be determined by rearranging Eq 18 as follows:

$$R_G = R_T - R_R - R_C \cos^2 h_1 \quad (\text{Eq 19})$$

$R_T$  may be measured in a test antenna installation on a vehicle using an R-X noise bridge or an SWR analyzer. You can then calculate  $R_R$  and  $R_C$ .

Ground loss is a function of vehicle size, placement of the antenna on the vehicle, and conductivity of the ground over which the vehicle is traveling. Only the first two variables can be feasibly controlled. Larger vehicles provide better ground planes than smaller ones. The vehicle ground plane is only partial, so the result is considerable RF current

flow (and ground loss) in the ground around and under the vehicle.

By raising the antenna base as high as possible on the vehicle, ground losses are decreased. This results from a decrease in antenna capacitance to ground, which increases the capacitive reactance to ground. This, in turn, reduces ground currents and ground losses.

This effect has been verified by installing the same antenna at three different locations on two different vehicles, and by determining the ground loss from Eq 19. In the first test, the antenna was mounted 6 inches below the top of a large station wagon, just behind the left rear window. This placed the antenna base 4 feet 2 inches above the ground, and resulted in a measured ground loss resistance of  $2.5 \Omega$ . The second test used the same antenna mounted on the left rear fender of a mid-sized sedan, just to the left of the trunk lid. In this test, the measured ground loss resistance was  $4 \Omega$ . The third test used the same mid-sized car, but the antenna was mounted on the rear bumper. In this last test, the measured ground loss resistance was  $6 \Omega$ .

The same antenna therefore sees three different ground loss resistances as a direct result of the antenna mounting location and size of the vehicle. It is important to note that the measured ground loss increases as the antenna base nears the ground. The importance of minimizing ground losses in mobile antenna installations cannot be overemphasized.

### Efficiency Curves

With the equations defined previously, a computer was used to calculate the radiation efficiency curves depicted in Figs 13, 14, 15 and 16. These curves were calculated for 3.8- and 7-MHz antennas of 8- and 11-foot lengths. Several values of loading coil Q were used, for both 2 and  $10 \Omega$  of ground loss resistance. For the calculations, the base section is  $\frac{1}{2}$ -inch diameter electrical EMT, which has an outside diameter of  $\frac{11}{16}$  inch. The top section is fiberglass bicycle-whip material covered with Belden braid. These are readily available materials, which can be used by the average amateur to construct an inexpensive but rugged antenna.

Upon inspection, these radiation-efficiency curves reveal some significant information:

- 1) Higher coil Q produces higher radiation efficiencies,
- 2) longer antennas produce higher radiation efficiencies,
- 3) higher frequencies produce higher radiation efficiencies,
- 4) lower ground loss resistances produce higher radiation efficiencies,
- 5) higher ground loss resistances force the loading coil above the antenna center to reach a crest in the radiation-efficiency curve, and
- 6) higher coil Q sharpens the radiation-efficiency curves, resulting in the coil position being more critical for optimum radiation efficiency.

Note that the radiation efficiency curves reach a peak and then begin to decline as the loading coil is raised farther up the antenna. This is because of the rapid increase in loading coil reactance required above the antenna center.

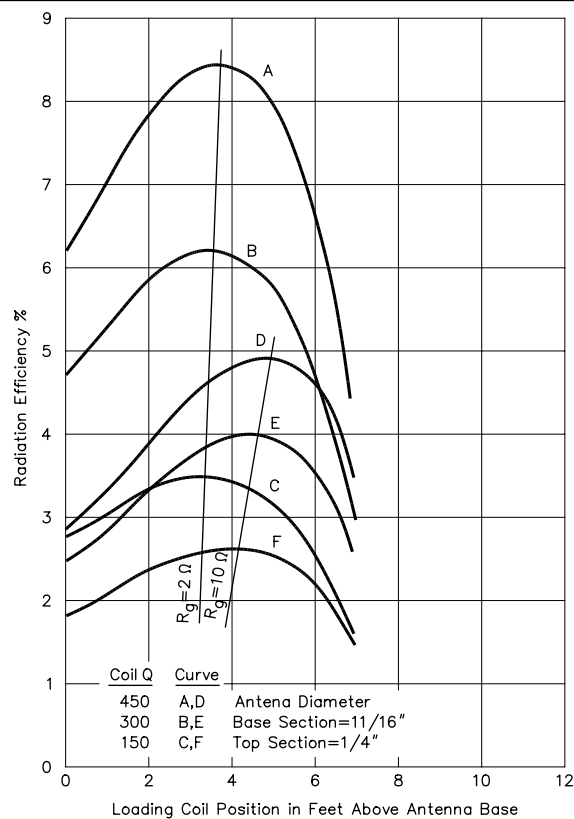


Fig 13—Radiation efficiency of 8-foot antennas at 3.9 MHz.

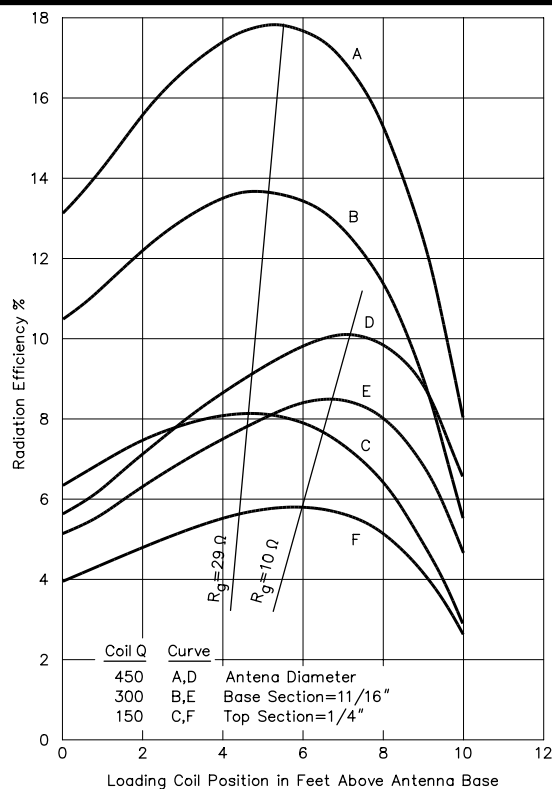
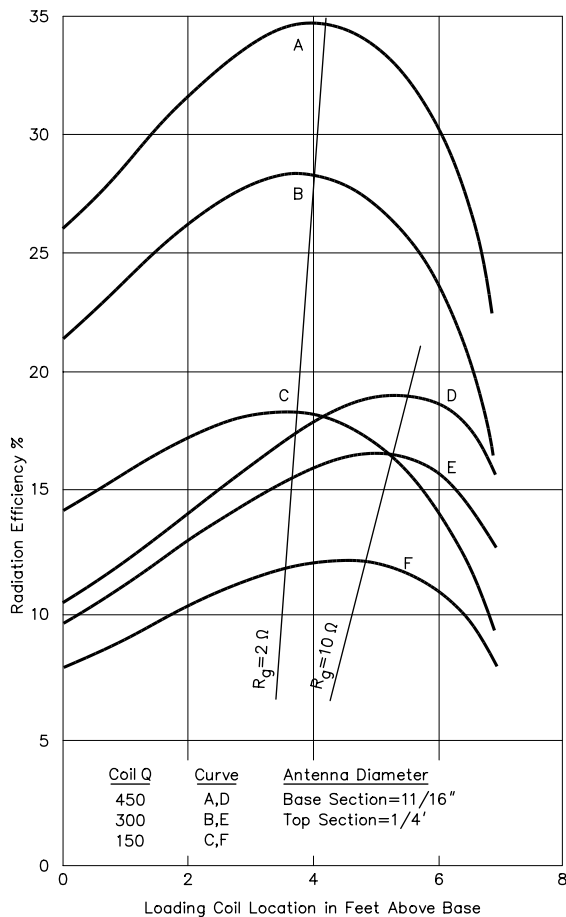
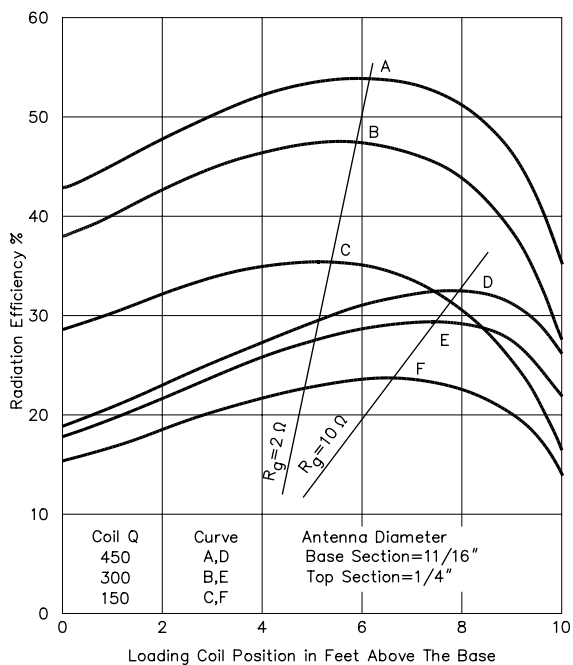


Fig 14—Radiation efficiency of 11-foot antennas at 3.9 MHz.



**Fig 15—Radiation efficiency of 8-foot antennas at 7.225 MHz.**



**Fig 16—Radiation efficiency of 11-foot antennas at 7.225 MHz.**

Refer to Fig 12. The rapid increase in coil size required for resonance results in the coil loss resistance increasing much more rapidly than the radiation resistance. This results in decreased radiation efficiency, as shown in Fig 11.

A slight reverse curvature exists in the curves between the base-loaded position and the one-foot coil-height position. This is caused by a shift in the curve resulting from insertion of a base section of larger diameter than the whip when the coil is above the base.

The curves in Figs 13, 14, 15 and 16 were calculated with constant (but not equal) diameter base and whip sections. Because of wind loading, it is not desirable to increase the diameter of the whip section. However, the base-section diameter can be increased within reason to further improve radiation efficiency. Fig 17 was calculated for base-section diameters ranging from 11/16 inch to 3 inches. The curves reveal that a small increase in radiation efficiency results from larger diameter base sections.

The curves in Figs 13, 14, 15 and 16 show that radiation efficiencies can be quite low in the 3.8-MHz band compared to the 7-MHz band. They are lower yet in the 1.8-MHz band. To gain some perspective on what these low efficiencies mean in terms of signal strength, Fig 18 was calculated using the following equation:

$$dB = \log \frac{100}{E} \quad (\text{Eq 20})$$

where

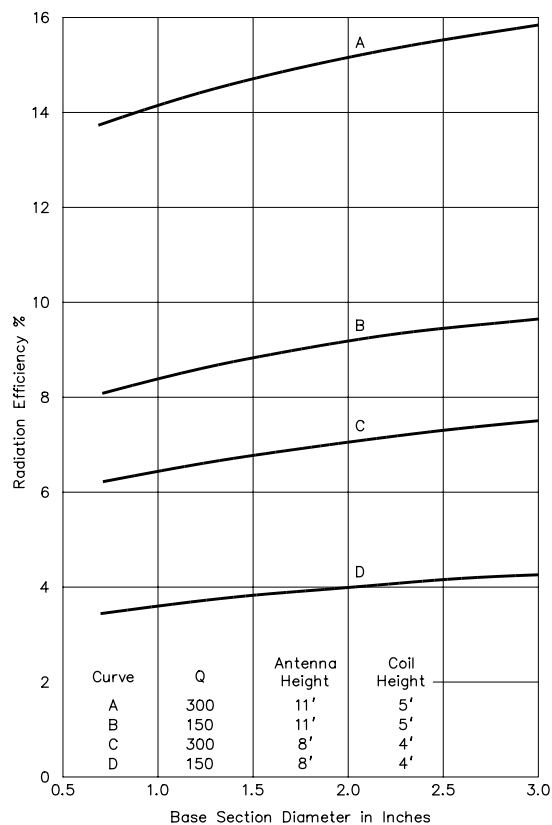
- dB = signal loss in decibels
- E = efficiency in percent.

The curve in Fig 18 reveals that an antenna having 25% efficiency has a signal loss of 6 dB (approximately one S unit) below a quarter-wave vertical antenna over perfect ground. An antenna efficiency in the neighborhood of 6% will produce a signal strength on the order of two S units or about 12 dB below the same quarter-wave reference vertical. By careful optimization of mobile-antenna design, signal strengths from mobiles can be made fairly competitive with those from fixed stations using comparable power. And don't forget: Moving your car near saltwater, with its high conductivity, can result in surprisingly strong signals from a mobile station!

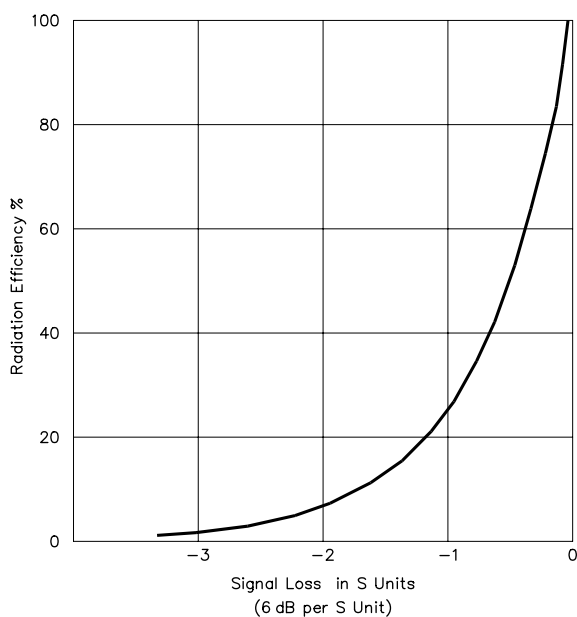
### Impedance Matching

The input impedance of short, high-Q coil-loaded antennas is quite low. For example, an 8-foot antenna optimized for 3.9 MHz with a unloaded coil Q of 300 and a ground-loss resistance of 2 Ω has a base input impedance of about 13 Ω. This low impedance value causes a standing wave ratio of 4:1 on a 50-Ω coaxial line at resonance. This high SWR is not compatible with the requirements of solid-state transmitters. Also, the bandwidth of shortened vertical antennas is very narrow. This severely limits the capability to maintain transmitter loading over even a small frequency range.

Impedance matching can be accomplished by means of



**Fig 17—Radiation efficiency plotted as a function of base section diameter. Frequency = 3.9 MHz, ground loss resistance = 2 Ω, and whip section = 1/4-inch diameter.**



**Fig 18—Mobile antenna signal loss as a function of radiation efficiency, compared to a quarter-wave vertical antenna over perfect ground.**

L networks or impedance-matching transformers, but the narrow bandwidth limitation remains. A more elegant solution to the impedance matching and narrow bandwidth problem is to install an automatic tuner at the antenna base. Such a device matches the antenna and coaxial line automatically, and permits operation over a wide frequency range.

The tools are now available to tailor a mobile antenna design to produce maximum radiation efficiency. Mathematical modeling with a personal computer reveals that loading coil Q factor and ground loss resistance greatly influence the optimum loading coil position in a short vertical antenna. It also shows that longer antennas, higher coil Q, and higher operating frequencies produce higher radiation efficiencies.

End effect has not been included in any of the equations to assure that the loading coil will be slightly larger than necessary. Pruning the antenna to resonance should be done by removing coil turns, rather than by shorting turns or shortening the whip section excessively. Shortening the whip reduces radiation efficiency, by both shortening the antenna and moving the optimum coil position. Shorting turns in the loading coil degrades the Q of the coil.

### Shortened Dipoles

Mathematical modeling techniques can be applied to shortened dipoles by using zero ground loss resistance and by doubling the computed values of radiation resistance and feed-point impedance. Radiation efficiency, however, does not double. Rather, it remains unchanged, because a second loading coil is required in the other leg of the dipole. The addition of the second coil offsets the gain in efficiency that occurs when the feed-point impedance and radiation resistance are doubled. There is a gain in radiation efficiency over a vertical antenna worked against ground, though, because the dipole configuration allows ground loss resistance to be eliminated from the calculations.

### CONTINUOUSLY LOADED ANTENNAS

The design of high-Q air core inductors for RF work is complicated by the number of parameters that must be optimized simultaneously. One of these factors affecting coil Q adversely is radiation from a discrete loading coil. Therefore, the possibility of cutting down other losses while incorporating the coil radiation into that from the rest of the antenna system is an attractive one.

The general approach has been to use a coil made from heavy wire (#14 or larger), with length-to-diameter ratios as high as 21. British experimenters have reported good results with 8-foot overall lengths on the 1.8- and 3.5-MHz bands. The idea of making the entire antenna out of one section of coil has also been tried with some success. This technique is referred to as linear loading. Further information on linear-loaded antennas can be found in [Chapter 6](#).

While going to extremes trying to find a perfect loading arrangement may not improve antenna performance very much, a poor system with lossy coils and high-resistance

connections must be avoided if a reasonable signal is to be radiated.

### MATCHING TO THE TRANSMITTER

Most modern transmitters require a 50-Ω output load, and because the feed-point impedance of a mobile whip is quite low, a matching network is usually necessary. Although calculations are helpful in the initial design, considerable experimenting is often necessary in final tune-up. This is particularly true for the lower bands, where the antenna is electrically short compared with a quarter-wave whip. The reason is that the loading coil is required to tune out a very large capacitive reactance, and even small changes in component values result in large reactance variations. Since the feed-point resistance is low to begin with, the problem is even more aggravated.

You can transform the low resistance of the whip to a value suitable for a 50-Ω system with an RF transformer or with a shunt-feed arrangement, such as an L network. The latter may only require a shunt coil or shunt capacitor at the base of the whip, since the net series capacitive or inductive reactance of the antenna and its loading coil may be used as part of the network. The following example illustrates the calculations involved.

Assume that a center-loaded whip antenna, 8.5 feet in overall length, is to be used on 7.2 MHz. From Table 1, earlier in this chapter, we see that the feed-point resistance of the antenna will be approximately 19 Ω, and from Fig 5 that the capacitance of the whip, as seen at its base, is approximately 24 pF. Since the antenna is to be center loaded, the capacitance value of the section above the coil will be cut approximately in half, to 12 pF. From this, it may be calculated that a center-loading inductor of 40.7 μH is required to resonate the antenna, that is, to cancel out the capacitive reactance. (This figure agrees with the approximate value of 40 μH shown in Table 1. The resulting feed-point impedance would then be 19 + j 0 Ω—a good match, if one happens to have a supply of 19-Ω coax.)

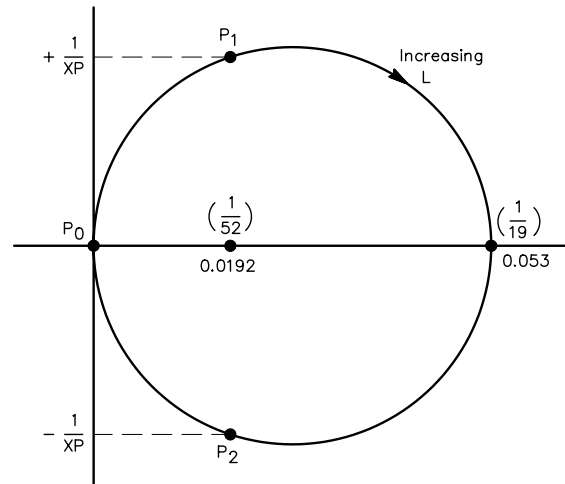
**Solution:** The antenna can be matched to a 52-Ω line such as RG-8 by tuning it either above or below resonance and then canceling out the undesired component with an appropriate shunt element, capacitive or inductive. The way in which the impedance is transformed up can be seen by plotting the admittance of the series RLC circuit made up of the loading coil, antenna capacitance, and feed-point resistance. Such a plot is shown in Fig 19 for a constant feed-point resistance of 19 Ω. There are two points of interest, P1 and P2, where the input conductance is 19.2 millisiemens, corresponding to 52 Ω. The undesired susceptance is shown as 1/X<sub>p</sub> and -1/X<sub>p</sub>, which must be canceled with a shunt element of the opposite sign, but with the same magnitude. The value of the canceling shunt reactance, X<sub>p</sub>, may be found from the formula:

$$X_p = \frac{R_f Z_0}{\sqrt{R_f (Z_0 - R_f)}} \quad (\text{Eq 21})$$

where X<sub>p</sub> is the reactance in Ω, R<sub>f</sub> is the feed-point resistance, and Z<sub>0</sub> is the feed-line impedance. For Z<sub>0</sub> = 52 Ω and R<sub>f</sub> = 19 Ω, X<sub>p</sub> = ±39.5 Ω. A coil or good quality mica capacitor may be used as the shunt element. With the tune-up procedure described later, the value is not critical, and a fixed-value component may be used.

To arrive at point P1, the value of the center loading-coil inductance would be less than that required for resonance. The feed-point impedance would then appear capacitive, and an inductive shunt matching element would then be required. To arrive at point P2, the center loading coil should be more inductive than required for resonance, and the shunt element would need to be capacitive.

The value of the center loading coil required for the shunt-matched and resonated condition may be determined from the equation:



**Fig 19—Admittance diagram of the RLC circuit consisting of the whip capacitance, radiation resistance and loading coil discussed in text. The horizontal axis represents conductance, and the vertical axis susceptance. The point P<sub>0</sub> is the input admittance with no whip loading inductance. Points P1 and P2 are described in the text. The conductance equals the reciprocal of the resistance, if no reactive components are present. For a series RX circuit, the conductance is given by**

$$G = \frac{R}{R^2 + X^2}$$

and the susceptance is given by

$$B = \frac{-X}{R^2 + X^2}$$

Consequently, a parallel equivalent GB circuit of the series RX one can be found which makes computations easier. This is because conductances and susceptances add in parallel the same way resistances and reactances add in series.

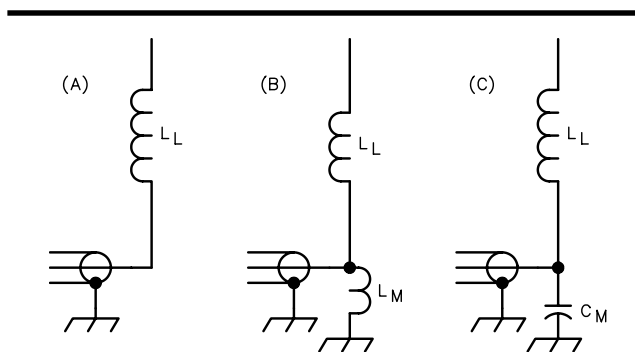
$$L = \frac{10^6}{4\pi^2 f^2 C} \pm \frac{X_S}{2\pi f} \quad (\text{Eq 22})$$

where addition is performed if a capacitive shunt is to be used, or subtraction performed if the shunt is inductive, and where  $L$  is in  $\mu\text{H}$ ,  $f$  is the frequency in MHz,  $C$  is the capacitance of the antenna section being matched in pF, and

$$X_S = \sqrt{R_f(Z_0 - R_f)} \quad (\text{Eq 23})$$

For the example given, where  $Z_0 = 52 \Omega$ ,  $R_f = 19 \Omega$ ,  $f = 7.2 \text{ MHz}$ , and  $C = 12 \text{ pF}$ ,  $X_S$  is found to be  $25.0 \Omega$ . The required antenna loading inductance is either  $40.2 \mu\text{H}$  or  $41.3 \mu\text{H}$ , depending on the type of shunt. Various matching possibilities for this example are shown in **Fig 20**. At A, the antenna is shown as tuned to resonance with  $L_L$ , a  $40.7 \mu\text{H}$  coil, but with no provisions included for matching the resulting  $19\text{-}\Omega$  impedance to the  $50\text{-}\Omega$  line. At B,  $L_L$  has been reduced to  $40.2 \mu\text{H}$  to make the antenna appear net capacitive, and  $L_M$ , having a reactance of  $39.5 \Omega$ , is added in shunt to cancel the capacitive reactance and transform the feed-point impedance to  $52 \Omega$ . The arrangement at C is similar to that at B except that  $L_L$  has been increased to  $41.3 \mu\text{H}$ , and  $C_M$  (a shunt capacitor having a negative reactance of  $39.5 \Omega$ ) is added, which also results in a  $52\text{-}\Omega$  nonreactive termination for the feed line.

The values determined for the loading coil in the above example point out an important consideration concerning the matching of short antennas—relatively small changes in values of the loading components will have a greatly magnified effect on the matching requirements. A change of less than 3% in the loading coil inductance value necessitates a completely different matching network!



**Fig 20**—At A, a whip antenna that is resonated with a center loading coil. At B and C, the value of the loading coil has been altered slightly to make the feed-point impedance appear reactive, and a matching component is added in shunt to cancel the reactance. This provides an impedance transformation to match the  $Z_0$  of the feed line. An equally acceptable procedure, rather than altering the loading coil inductance, is to adjust the length of the top section above the loading coil for the best match, as described in the tune-up procedure of the text.

Likewise, calculations show that a 3% change in antenna capacitance will give similar results, and the value of the precautions mentioned earlier becomes clear. The sensitivity of the circuit with regard to frequency variations is also quite critical, and an excursion around practically the entire circle in **Fig 19** may represent only 600 kHz, centered around 7.2 MHz, for the above example. This is why tuning up a mobile antenna can be very frustrating unless a systematic procedure is followed.

### Tune-Up

Assume that inductive shunt matching is to be used with the antenna in the previous example, **Fig 20B**, where  $39.5 \Omega$  is needed for  $L_M$ . This means that at 7.2 MHz, a coil of  $0.87 \mu\text{H}$  will be needed across the whip feed-point terminal to ground. With a  $40\text{-}\mu\text{H}$  loading coil in place, the adjustable whip section above the loading coil should be set for minimum height. Signals in the receiver will sound weak and the whip should be lengthened a bit at a time until signals start to peak. Turn the transmitter on and check the SWR at a few frequencies to find where a minimum occurs. If it is below the desired frequency, shorten the whip slightly and check again. It should be moved approximately  $1/4$  inch at a time until the SWR is minimum at the center of the desired range. If the frequency where the minimum SWR occurs is above the desired frequency, repeat the procedure above, but lengthen the whip only slightly.

If a shunt capacitance is to be used, as in **Fig 20C**, a value of  $560 \text{ pF}$  would correspond to the required  $-39.5 \Omega$  of reactance at 7.2 MHz. With a capacitive shunt, start with the whip in its longest position and shorten it until signals peak up.

### TOP-LOADING CAPACITANCE

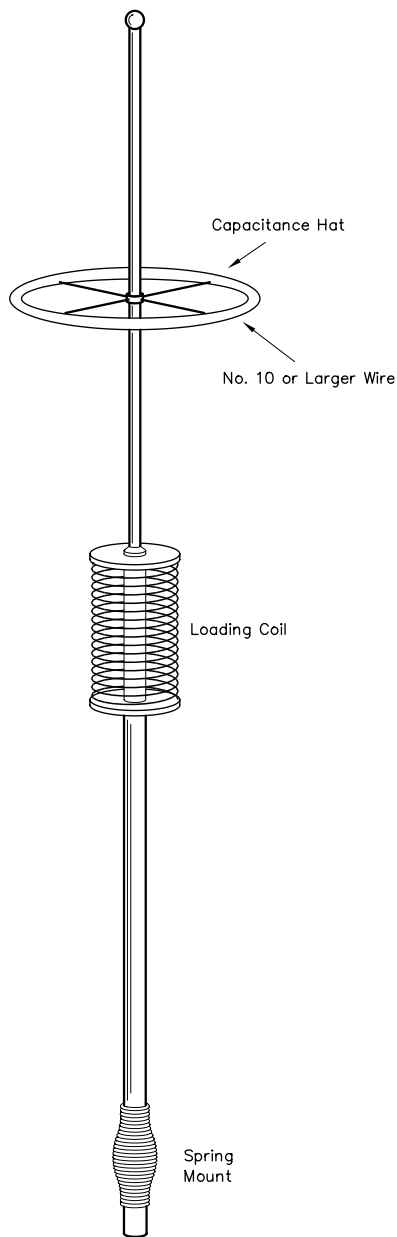
Because the loss resistance varies with the inductance of the loading coil, the resistance can be reduced by removing turns from the coil. This must be compensated by adding capacitance to the portion of the mobile antenna that is *above* the loading coil (**Fig 21**). *Capacitance hats*, as they are called, can consist of a single stiff wire, two wires or more, or a disc made up of several wires like the spokes of a wheel. A solid metal disc could also be used, but is less practical for mobile work. The larger the capacitance hat (physically), the greater is the capacitance. The greater the capacitance, the less is the inductance required for resonance at a given frequency.

Capacitance-hat loading is applicable in either base-loaded or center-loaded systems. Since more inductance is required for center-loaded whips to make them resonant at a given frequency, capacitance hats are particularly useful in improving their efficiency.

### TAPPED-COIL MATCHING NETWORK

Some of the drawbacks of the L-network can be eliminated by the use of the tapped-coil arrangement shown in **Fig 22**. Tune-up still remains critical, however, although somewhat more straightforward than for an L-network. Coil  $L_2$  can be inside the car body, at the base of the antenna, or



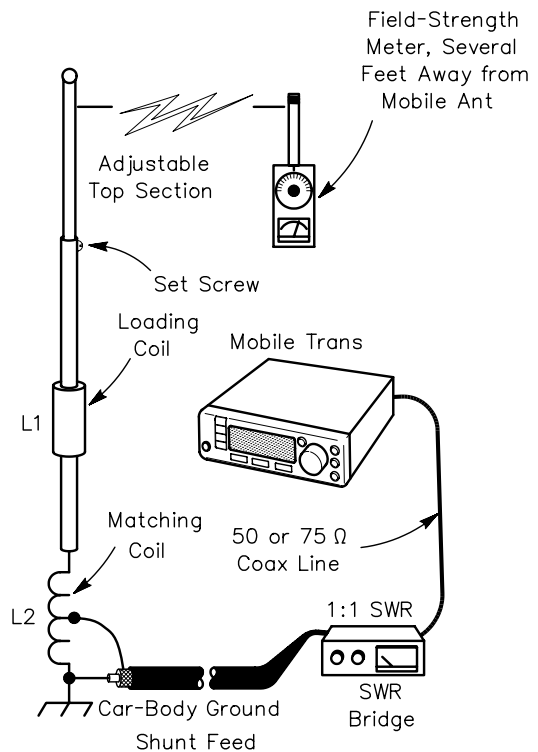


**Fig 21—A capacitance hat can be used to improve the performance of base- or center-loaded whips. A solid metal disc can be used in place of the skeleton disc shown here.**

at the base of the whip. As L2 helps determine the resonance of the antenna, L1 should be tuned to resonance in the desired part of the band with L2 in the circuit. The top section of the whip can be telescoped until a field-strength maximum is found. The tap on L2 is then adjusted for the lowest reflected power. Repeat these two adjustments until no further increase in field strength can be obtained; this point should coincide with the lowest SWR. The number of turns needed for L2 will have to be determined experimentally.

### MOBILE IMPEDANCE-MATCHING COIL

Bob Hawk, K0YEH, designed this shunt-coil



**Fig 22—A mobile antenna using shunt-feed matching. Overall antenna resonance is determined by the combination of L1 and L2. Antenna resonance is set by pruning the turns of L1, or adjusting the top section of the whip, while observing the field-strength meter or SWR indicator. Then adjust the tap on L2 for the lowest SWR.**

L-network system for HF mobile antennas and dubbed it the K0YEH Dollar Special. Its primary purpose is to provide a very efficient match to 50-Ω coax line, and not to base-load the antenna. The antenna itself should already be resonated for the band of operation, preferably using a center loading inductor for efficiency. K0YEH used a Hustler antenna and resonator on his car. See Fig 23.

The Dollar Special is a great performer, fun to build, and costs only about a dollar for parts. If you have a junk box, you probably already have just about everything you'll need. With the matcher properly installed and adjusted, you will be able to get on any of the HF bands (3.5 through 29.7 MHz) for which your antenna is designed, with a 1:1 SWR.

The matching unit is shown in Fig 24. It adapts easily to passenger cars, pickup trucks, vans, trailers and RVs, as long as there is a metal body for a ground. Body mounts are better than bumper mounts for a number of reasons. The matcher can, however, be bumper mounted, and will still perform reasonably well in this configuration.

A 3.5-MHz mobile whip, resonated as an electrical quarter-wave antenna, typically presents a load impedance of about 8 Ω, and this represents a mismatch of more than 6 to 1! Similar mismatches (but of lesser magnitudes as frequency is increased) occur on the higher bands as well.

The matching coil is easy and efficient to use after initial tune-up. After finding the best coil tap using the alligator clip, you should mark the tap position with fingernail polish. Band changing may then be done easily, usually within a couple of minutes (depending on the length of time you need to change resonators).

### Construction

**Fig 25** shows a drilling template for the matching-coil assembly, and **Fig 26** shows details of the insulation standoff block. **Table 4** contains a list of materials needed for the Dollar Special. Carefully lay out the reference lines on the base plate, using a needle-point scribe and a ruler. Mark and drill all holes. The large 1.34-inch diameter hole may be cut out with a nibbling tool or a chassis punch, or you can drill several holes in the area and file them out. After drilling and cutting all holes, make a 90° bend at bend-line Z.

To form the loading coil, find a piece of 1/4-inch diameter tubing or pipe that is at least a foot long. Use it as a form and wind the #10 copper wire tightly around it. About 20 1/2 turns make up the coil. After winding, carefully spread the coil turns as evenly as possible so that the coil is 5 inches long with 20 turns. On one end of the coil, fashion a loop to fit snugly around the 3/16-inch bolt. (This bolt will be attached at point D, shown at the left in Fig 25.)

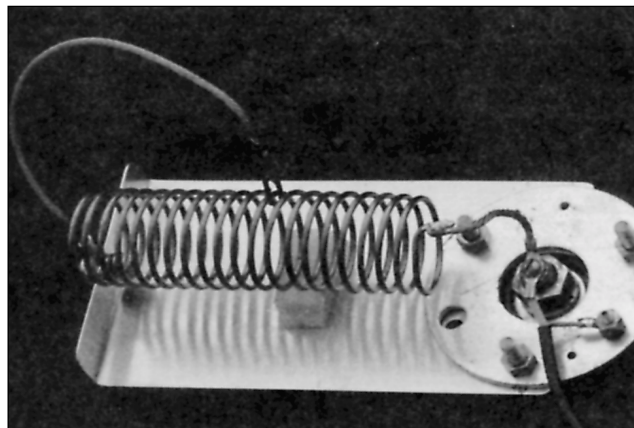
Bend the extra 1/2 turn at the feed-point end of the coil at a 45° angle (about 1/2 inch from the end of the 20th turn) and cut off the excess. Attach the end of the 2 3/8 inch length of braid at this point and solder. Wrapping the joint with fine solid copper wire (about #24) before soldering makes the soldering job easier.

Fabricate the standoff insulator as shown in Fig 26. With a file or knife, remove material at the top center, as shown, to avoid sharp edges against the coil tie-down material. Next mount the dielectric standoff to the base at points E and F using two no. 5 screws. In mounting the dielectric piece, make sure that hole J is parallel to the base plate and to the axis of the mounted coil.

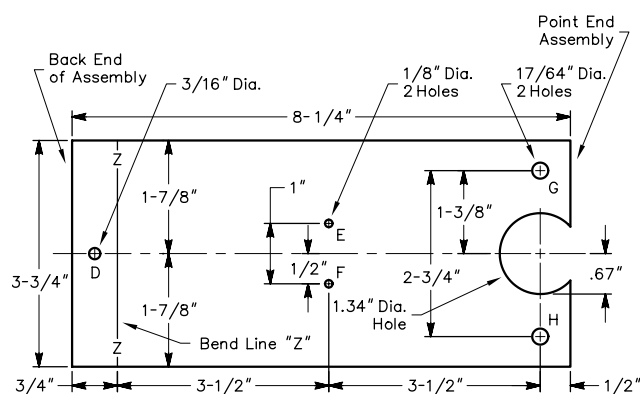
Secure the ground end of the coil and the terminal end of the 7-inch length of braid at hole D with the 3/16-inch bolt assembly. Connect the one bottom turn of the coil to the standoff with a 2- or 3-foot piece of cord or string (fishing line works well) through hole J.



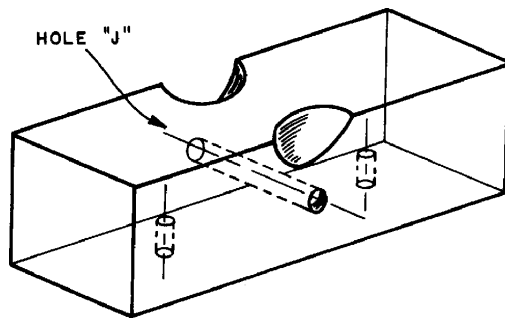
**Fig 23**—Bob Hawk showing off his mobile antenna, which uses the K0YEH Dollar Special matching unit.



**Fig 24**—The assembled Dollar Special, ready for mounting.



**Fig 25**—Drilling template for the base plate of the Dollar Special.



**Fig 26—Insulated standoff (to support the coil). Mount on the base at holes E and F with two small (no. 5) sheet-metal screws. Trim the top center, as shown, to about  $\frac{1}{8}$  to  $\frac{1}{4}$  inch wide. The insulation block is about  $\frac{1}{2}$  inch square  $\times$   $1\frac{3}{4}$ -inch. Drill a  $\frac{1}{8}$ -inch hole at J (for fishing line) to tie to the bottom of one coil turn.**

**Table 4**

**Materials Needed to Construct the Dollar Special**

- 1) Aluminum or brass sheet  $3\frac{3}{4}$  inch wide,  $7\frac{3}{4}$  inch long, and about 0.040 to 0.050 inch thick.
- 2) One  $9\frac{1}{2}$  foot length of #10 solid copper wire.
- 3) Flexible braid about  $\frac{5}{16}$  to  $\frac{3}{8}$  inch wide: one length  $7\frac{1}{2}$  inch long with a terminal for a no. 10 metal bolt on one end and a no. 30c Mueller clip (small copper alligator clip) soldered to the other end. The second piece of braid should be  $3\frac{3}{8}$  inch long with a terminal for a no. 8 screw soldered to one end.
- 4) One piece of dielectric (insulating) material about  $\frac{1}{2}$  to  $\frac{5}{8}$  inch square and about 2 inch long. This can be plastic such as nylon, Teflon, polyethylene or phenolic, or dry wood (if wood, preferably painted or boiled in paraffin).
- 5) One no. 10-32  $\times$   $\frac{3}{4}$  inch bolt, three star washers, two flat washers, and one lock washer.
- 6) Two no. 5 sheet-metal screws,  $\frac{3}{8}$ -inch long, to mount the dielectric standoff at points X and Y.

Your Dollar Special should now be complete and ready for mounting. The secret of the outstanding performance of any mobile antenna is good grounding. Be sure to observe the precautions given in the next section about removing paint from the vehicle body.

**Mounting the Matcher**

The Dollar Special is easily mounted. If you have a standard (preferably heavy duty) swivel mount on your vehicle, remove two of the (usually 3) bolts from the mount and slip the base of the matcher underneath the heavy ring plate (approximately 4-inch diameter). Connect the “hot” (feed-point) end of the coil, with attached terminal, to the

same feed-point connector as the center conductor of the coax. Make sure the shield of the coax is grounded to the large mounting ring with a short length of the shield braid (2 inches long or less).

Make sure the hole in the matcher base (about 1.34 inches) is properly centered so it does not touch and short out the center bolt assembly of the antenna. It is a good idea to make sure you have at least about  $\frac{1}{8}$  to  $\frac{3}{16}$  inch of clearance here.

Remove the antenna mount completely and remove all the paint and primer from at least a 1-inch diameter area around each of the bolt holes on the inner side of the mount. It is essential to obtain the best possible ground to the vehicle body. Star washers should be used between all contacting surfaces, and the hardware must be tightened well.

If you do not have a standard mount, make the appropriate connections to the antenna you are using based on these instructions. Mounting may take a little creativity, but the Dollar Special can be made to work with virtually any kind of mobile antenna.

**Tune-Up**

Place an SWR meter in the transmission line at the output of the transceiver. To avoid possible damage to the final amplifier and to prevent any unnecessary interference, tune-up should be done with the SWR meter at maximum sensitivity and the RF drive adjustments at no more than necessary to get an accurate SWR indication. Because 7 MHz is one of the most popular mobile bands, it is desirable to begin the tune-up procedure there. (Adjustment of each of the other bands is similar.)

First, move the alligator clip on the matching coil to the eighth turn from the feed-point end of the coil. Make a few spot SWR checks and determine where the SWR is lowest. If the SWR improves as you move toward the top of the band (7.3 MHz), you’ll need to lengthen the resonator whip a small amount or use more inductance in your center loading coil. Conversely, if you find the SWR best at the bottom of the band, you will need to shorten the whip or use less center-loading inductance. You will also need to move the alligator clip on the Dollar Special coil (check the SWR while you do this) a turn or half-turn at a time until you eventually find the coil-tap position that yields the best match.

After you have completed the tuning, the SWR should be at (or near) 1:1 at the desired frequency. On the 7-MHz band you should be able to move 10 to 15 kHz either way from this frequency with less than a 1.5:1 SWR. On 14 MHz and higher bands, you should be able to work the entire SSB subband with less than a 1.5:1 SWR. (These figures will vary somewhat depending on the antenna that you are using, but these numbers are typical for a Hustler antenna.) Measured SWR curves are shown in **Fig 27**.

Once you have found the best tap position on the matching coil for 7 MHz, mark it with red enamel or fingernail polish. This single tap position on the matching coil should be usable across the entire 7-MHz band.

Frequency excursions of more than 15 or 20 kHz from the center of the desired frequency range will require changing the length of the whip top section accordingly.

The other bands are tuned in a similar manner. Approximate tap positions on the matching coil for the other bands (counting from the feed-point end of the coil) are as follows.

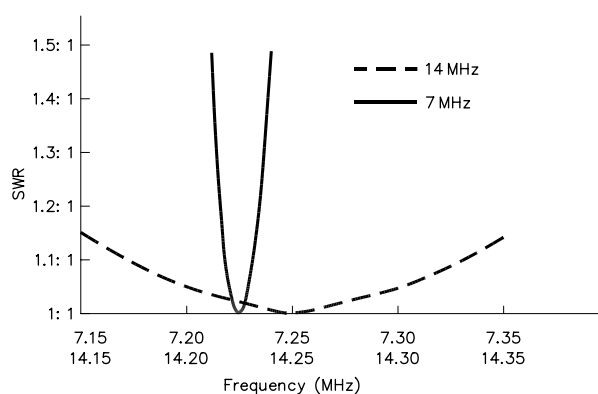
- 3.5 MHz—15 turns
- 7 MHz—8 turns
- 14 MHz—4½ turns
- 21 MHz—3 turns
- 28 MHz—2 turns

Most commercially made masts (Hustler, for example) are 4.5 feet long, and are made of approximately ½-inch OD tubing with ⅜-inch × 24 threaded fittings. If you are fortunate enough to find the material and have the capability, make a 1½ foot extension to add to the top of your mast, or else use a 6-foot mast. Your reward will be significantly improved operation on the 3.5- through 21-MHz bands.

### TWO-BAND HF ANTENNA WITH AUTOMATIC BANDSWITCHING

A popular HF mobile antenna is a center-loaded whip consisting of a loading coil mounted 2 to 4 feet from the base, with a whip atop the coil. A shorting-tap wire is provided to short out turns at the bottom end of the coil, bringing the antenna to resonance. Another popular scheme uses a commercial resonator, consisting of a coil and a short top section, mounted on the short mast.

It is obvious that to change bands with these HF antennas, the operator must stop the car, get out, and change the coil tap or resonator. Further, if a matching arrangement is used in the trunk of the vehicle at the antenna mount (such



**Fig 27—Typical SWR curves for the 7- and 14-MHz amateur bands. At 14 MHz, with adjustment centered on 14.25 MHz, the entire voice band is covered with an SWR of less than 1.2 to 1. Operation is similar at 21 and 28 MHz. At 7 MHz, the bandwidth is narrower, which is even more true for 3.5 MHz. A match may be obtained after significant frequency shifts in these bands by adjusting the antenna resonator.**

as a shunt L or shunt C), the matching reactance must also be changed. The antenna described in this section was developed by William T. Schrader, K2TNO, to provide instant band changing.

One approach to instant band changing is to install a pair of relays, one to switch the loading-coil tap and one to switch the matching reactance. (Of course, this is not practical with an antenna resonator.) In addition to the problem of running relay lines through the passenger compartment, this approach is a poor one because the coil-tap changing relay would need to be at the coil, adding weight and wind load to an already cumbersome antenna. Furthermore, that relay would need to be sealed, as it would be exposed to the weather.

The solution here allows automatic band changing, depending upon only the frequency of the signal applied to the antenna. The antenna described provides gratifying results; it shows an SWR of less than 1.2:1 at both the 7- and 14-MHz design frequencies. The chosen method employs two resonant circuits, one that switches the matching capacitance in and out, and one that either shorts or opens turns of the coil, depending upon the excitation frequency. See Fig 28.

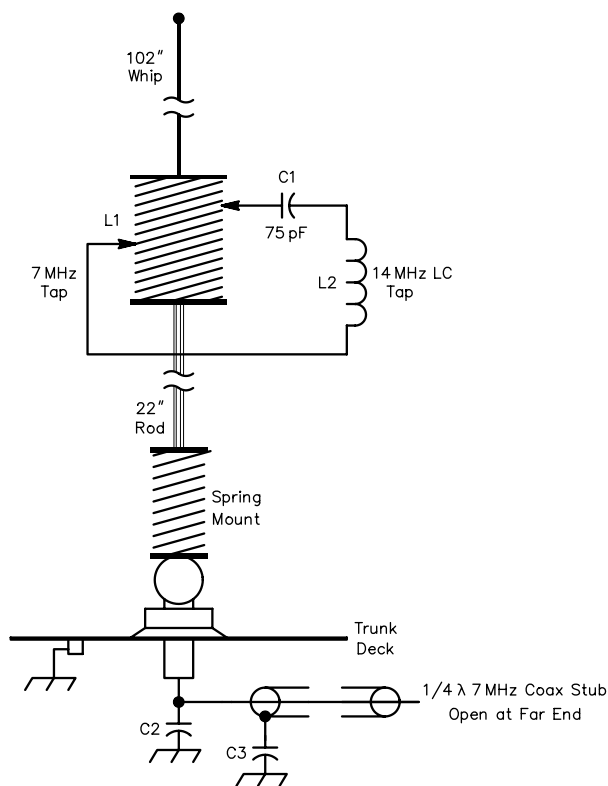
### Coil-Tap Switching

A series LC circuit looks electrically like a dead short at its resonant frequency. Below that frequency it presents a capacitive reactance; above resonance it looks inductive. A series resonant network, L2-C1, is resonant at the 14-MHz design frequency. One end of C1 is connected to the 14-MHz tap point on the coil, and the other end is connected to the bottom of the coil. On 14 MHz, the network looks like a short circuit and shorts out the unwanted turns at the bottom end of the coil. At 7 MHz the network is not a short, and therefore opens the bottom turns (but adds some reactance to the antenna).

A coil-tapping clip is soldered to the stud at one end of C1. The other end of C1 is connected to L2. A dip meter is used to prune L2 until the L2-C1 network is resonant somewhere in the 14-MHz CW band. The design of the plastic supports on L2 limits pruning of the coil to ¼-turn increments. One lead of L2 should be cut close to the plastic and the short pigtail attached with a machine screw to the capacitor stud. The far end of L2 should have a long pigtail (about 5 to 6 inches) to secure the lower end of the network to the bottom of the antenna loading coil, L1. While resonating the network, the long pigtail can be bent around to clip to the top of the capacitor to form a parallel-resonant circuit.

Any doorknob capacitor between about 25 and 100 pF could be used for C1. The lower the value of C, the larger the coil inductance will need to be. A 1000-V silver mica capacitor would also work, but the doorknob is preferred because of the mechanical stability it provides.

The LC network should be mounted to the main coil, with the lower coil pigtail extended down roughly parallel to the main coil. Some turns adjustment will be required, so



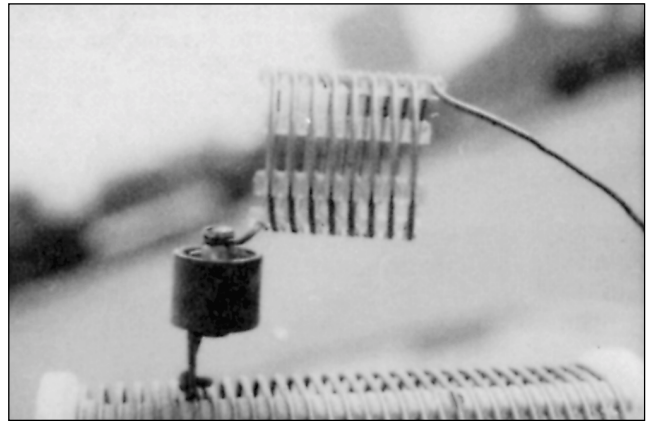
**Fig 28—Details of the 7- and 14-MHz mobile antenna.**  
**C1—Ceramic doorknob capacitor. See text.**  
**C2—14 MHz matching. See text for determining value. May be made up of two or three parallel-connected 1000-V silver mica capacitors to obtain the required value.**  
**C3—7 MHz matching, parallel-connected 1000-V silver mica capacitors or air variable. See text.**  
**L1—Multiband center loading coil for mobile antenna.**  
**L2—8½ turn coil (B & W #3046), 1¼ inch diameter, 6 turns per inch.**

this pigtail should not be tight. The mounting details are visible in **Fig 29**.

### Tuning the Antenna

Once the LC network is attached, the antenna must be tuned for the 7- and 14-MHz bands. This job *requires* the use of an impedance-measuring device such as an R-X noise bridge (home-built or commercial, either is fine) or an SWR analyzer. As with many antenna projects, you're just wasting your time if you try to do the job with an SWR meter alone. Prepare a length of coax feed line that is an electrical half wavelength at the 7-MHz design frequency. Do not attempt to use the vehicle coax feed line unless you want to do a lot of Smith Chart calculations.

Once the special feed line is attached, install the impedance bridge and begin the tuning as follows. The antenna must first be resonated to each band by adjusting the taps on L1, first for 7 and then for 14 MHz. Mark these



**Fig 29—Close-up of the mounting arrangement of the 14-MHz LC network on the main tuning coil. The antenna was pulled to a nearly horizontal position and the camera tilted slightly for this photograph.)**

two tap locations on the coil. Then using the steps that follow, perform tuning for the 14-MHz design frequency.

- 1) Move the 7-MHz tap wire up the coil to a new position that leaves about 60% of the original turns unshorted.
- 2) Listen at 14 MHz and adjust the impedance bridge for a null. The reactance dial should show capacitive reactance. Move the LC-network tap point down the coil about ¼ turn at a time until the bridge indicates pure resistance.
- 3) Switch to 7 MHz and follow the same procedure. On this band, move the shorting wire about ½ turn at a time. Do not be surprised if it takes some hunting to find resonance; tuning is very critical on 7 MHz.
- 4) The two adjustments interact; repeat steps 2 and 3 of this section for both bands until the measured impedance is purely resistive at both design frequencies.
- 5) Remove the impedance bridge and install an SWR meter. Determine the SWR on both bands. The minimum SWR should be about 1.5:1 on 14 MHz and about 2.2:1 on 7 MHz. Shift the VFO frequency about 10 kHz above and below the design frequencies on both bands to verify that the minimum SWR occurs at the design frequencies. Do not expect the minimum SWR to be 1:1, because the antenna is not yet matched to the line. Alternate bands and adjust the two taps slightly for minimum SWR at the desired frequencies for both bands.
- 6) Record the SWR and tap points for both bands. This completes the adjustments for the resonating work.

### Designing the Matching Networks

Since the feed-point impedance is not 52 Ω on either band, a matching network is needed for each. Matching can be done easily with an L network, as described earlier in this chapter and in [Chapter 25](#). Schrader's network consists of a shunt capacitor from the antenna feed point to ground and a compensating increase in the coil inductance of L1, obtained by moving the tap slightly. The value of the

matching capacitor is calculated by knowing  $R_A$ , the antenna feed-point resistance at resonance,  $Z_0$ , the impedance of the coax feed line, and  $f$ , the operating frequency in kHz.

- 1) Calculate the antenna feed-point resistance from the relationship  $SWR = Z_0 / R_0$ . Do this calculation for both bands. For the antenna Schrader constructed, values of  $R_0$  were  $33.3 \Omega$  on 14 MHz and  $21.4 \Omega$  on 7 MHz.
- 2) Calculate the value for C2, the 14-MHz matching capacitor. This is the value obtained for  $C_M$  from

$$C_M = \frac{\sqrt{R_A (Z_0 - R_A)}}{2\pi f Z_0 R_A} \quad (\text{Eq 23})$$

where

$C_M$  is the matching capacitance in pF  
 $R_0$  and  $Z_0$  are in  $\Omega$   
 $f$  is in MHz.

Using Schrader's value of  $R_0$  as an example, the capacitance is calculated as follows.

$$C_M = \frac{\sqrt{33.3(52 - 33.3)}}{2\pi \times 14.06 \times 52 \times 33.3} \times 10^6 = 163 \text{ pF}$$

This is the value for C2. A practical value is 160 pF.

- 3) From Eq 24, calculate the total matching capacitance required for 7 MHz. Again, using Schrader's value,

$$C_M = \frac{\sqrt{21.4(52 - 21.4)}}{2\pi \times 7.06 \times 52 \times 21.4} \times 10^6 = 518 \text{ pF}$$

- 4) Because C2 is present in the matching circuit at both 7 and 14 MHz, the value of C3 is not the  $C_M$  value just calculated. Calculate the value of C3 from

$$C3 = C_M - C2 \quad (\text{Eq 24})$$

where  $C_M$  is the value calculated in step 3 of this section.

In this example,  $C3 = 518 - 163 = 355 \text{ pF}$ .

### Final Tuning of the Antenna

Install C2 from the antenna feed point to ground. Now readjust the tap point of the 14-MHz LC network to add just enough additional inductance to give a  $50\text{-}\Omega$  feed-point resistance. The tap point will be moved down (more turns in use) as the match is approached.

- 1) Attach the SWR meter and apply RF at 14 MHz (10 W or so). Note that the SWR is higher than it was before C2 was added.
- 2) Move the tap point down the coil about  $1/8$  turn at a time. Eventually the SWR will begin to fall, and there will be a point where it approaches 1:1. For the antenna in the photos, almost a full additional coil turn was necessary on 14 MHz.
- 3) Verify (by shifting the VFO) that the minimum SWR occurs at the 14-MHz design frequency. Adjust the tap point until this condition is met. Note: If the SWR never falls to nearly 1:1, either  $C_M$  was miscalculated, the SWR

was not measured correctly, the antenna was not resonant, or the measuring coax feed line was not actually  $1/2$  wavelength long on 7 MHz.

- 4) Add C3 in parallel with C2. Repeat steps 2 and 3 of this section at 7 MHz, moving the 7-MHz tap wire.
- 5) Recheck 14 and 7 MHz. Both bands should now show a low SWR (less than 1.2:1) at the design frequencies. Note: The grounded end of C3 must be lifted when you recheck 14 MHz and then reconnected for 7 MHz.

Now the antenna is resonant and properly matched on both bands, but C3 must be manually grounded and ungrounded to change bands. This problem may be solved as described below.

### Matching Capacitor Switching

A length of coaxial cable (any impedance) that is exactly one-quarter wavelength long at a given frequency and is open-circuited at its far end will be resonant at that frequency. At this frequency, the input end of the coax appears as a dead short. If a signal of twice the frequency is applied, the line is  $1/2 \lambda$  long at that frequency, and the input terminals of the line are not shorted, but rather present a very high impedance (an open circuit, in theory). This property of quarter- and half-wavelength transmission lines can be used as a switch in this antenna, because the two frequencies in use are harmonically related.

Cut a length of RG-58 to resonate at the 7-MHz design frequency (about 22 feet), and leave the far end open. High RF voltages exist at this end, so it is a good idea to insulate it. Strip back the braid about  $3/16$  inch and tape the end of the cable. This length of coax acts as an automatic switch to either ground or lift the low side of C3.

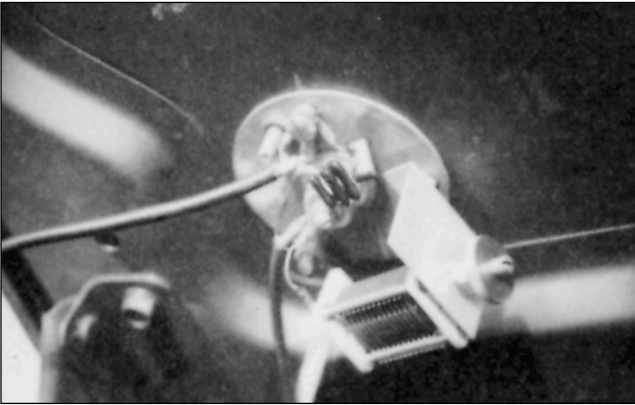
Connect one lead of C3 to the antenna feed point, and the other end to the center conductor of the coax stub, as shown in the diagram of Fig 28. Ground the braid of the coax at the base of the antenna. This circuit grounds the low end of the capacitor on 7.060 MHz, but opens it on 14.060 MHz automatically, depending on the frequency of the signal applied to it. Details of the matching network are shown in Fig 30.

Coil the coax stub and place it out of the way (in the trunk or wherever is convenient). Coiling does not affect stub tuning at all.

### Operation of the Antenna

With antenna adjustments completed, remove the  $1/2$ -wavelength feed line and reinstall the regular feed line. The antenna should now be operable on either band with a very low SWR. Because of the high Q of the open-wire coil and the antenna, bandwidth is limited on 7 MHz. An antenna tuner can be used to allow wide frequency excursions. If only a small segment of the 7-MHz band is to be used, no tuner is necessary.

The L2-C1 network should be positioned behind the main coil for minimum wind buffeting. As its attachment point is dictated by the electrical requirements, the network can be rotated behind the coil by installing a washer on the



**Fig 30**—Details of the matching network located at the base of the antenna inside the vehicle. The mica capacitors are visible at the center. The coaxial stub used to switch them in and out of the circuit comes in from the left, and the feed line exits toward the bottom of the photo.

$\frac{3}{8}$ -inch  $\times$  24 stud where the bottom of the coil is attached to the lower mast. The antenna is shown installed on a vehicle in **Fig 31**.

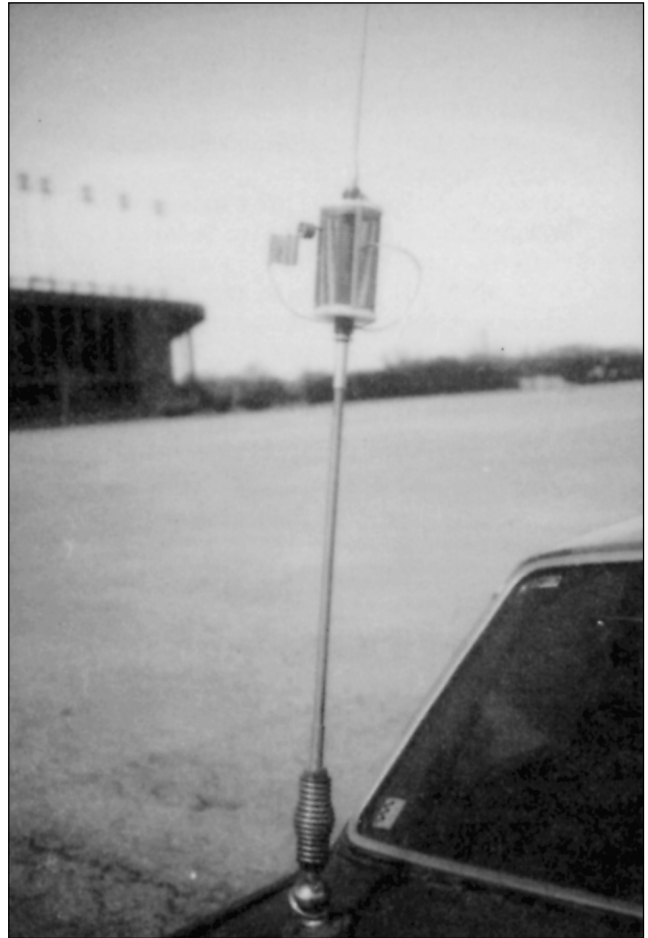
Orientation of the tap wire and the LC bottom tap wire have a large effect on tuning. Be sure to orient these leads during tuning in the same way that you will when using the antenna.

SWR measurements have been made with various tap positions of both the 14-MHz LC trap and the 7-MHz tap wire. The results are summarized in **Table 5**. With the matching and switching system installed as described, the antenna showed an SWR of 1:1 at the transmitter on both bands. The 2:1 SWR bandwidth was about 40 kHz on 7 MHz, and over 350 kHz on 14 MHz.

Table 5 includes typical coil-tap settings for changing the resonant frequency on both bands. Exact tap positions will depend upon the geometry of the antenna, its position on the vehicle and the arrangement of the leads themselves. The table also shows how the two band adjustments interact. For example, with the 14-MHz LC tap at  $6\frac{1}{4}$  turns, changing the 7-MHz tap from  $11\frac{1}{2}$  to 12 turns moved the 7-MHz resonance point from 7.267 to 7.104 MHz. There was also a 30-kHz change in the 14-MHz resonance point, from 14.190 to 14.160 MHz. The inverse effect was even more pronounced. With 12 turns in use for the 7-MHz tap, moving the 14-MHz LC tap from  $6\frac{1}{4}$  to  $6\frac{1}{2}$  turns altered the 14-MHz frequency from 14.160 to 14.085 MHz. Simultaneously the 7-MHz resonant frequency shifted from 7.104 to 7.207 MHz. Thus, both settings interact strongly.

Since the bandwidth on 14 MHz is nearly sufficient to cover the entire amateur band without adjustment, the settings of the 14-MHz LC network are not very critical. However, as Table 5 shows, slight readjustments of either tap will have marked effects upon 7-MHz performance.

Typical SWR curves for the two bands are shown in **Figs 32** and **33**. **Fig 32** shows that moving the 14-MHz LC



**Fig 31**—This photo shows the antenna mounted on the trunk of a car. The structure is somewhat cumbersome, so it is guyed appropriately.

**Table 5**  
**Coil Tap Positions for the Two-Band Mobile Antenna**

<i>Unshorted Turns<sup>1</sup></i>		<i>Resonant Frequency (MHz)<sup>2</sup></i>	
<i>14-MHz LC</i>	<i>7-MHz Tap</i>	<i>14-MHz Band</i>	<i>7-MHz Band</i>
$6\frac{1}{4}$	$11\frac{1}{2}$	14.190	7.267
	$11\frac{3}{4}$	14.170	7.144
	12	14.160	7.104
	$12\frac{1}{4}$	—	7.034
	$6\frac{1}{2}$	12	14.085
$6\frac{1}{2}$	$12\frac{1}{4}$	14.070	7.080
	$12\frac{1}{2}$	14.020	7.005

<sup>1</sup>Turns in use (measured from the top of the coil).

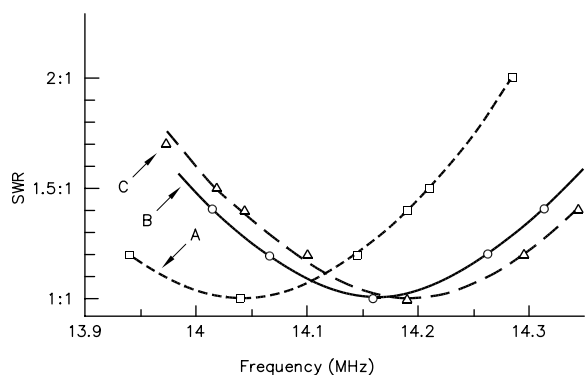
<sup>2</sup>Frequency at which SWR is 1:1.

tap point from  $6\frac{1}{2}$  to  $6\frac{1}{4}$  turns raised the resonant frequency from 14.040 to 14.168 MHz. The 7-MHz tap was set at 12 turns for these measurements. When the 7-MHz tap was moved to  $11\frac{1}{2}$  turns, the 14-MHz resonant frequency was raised to 14.190 MHz. The 14-MHz LC tap was kept constant for the measurements shown in **Fig 33**, and the difference in resonant frequency that results from moving the 7-MHz tap is shown.

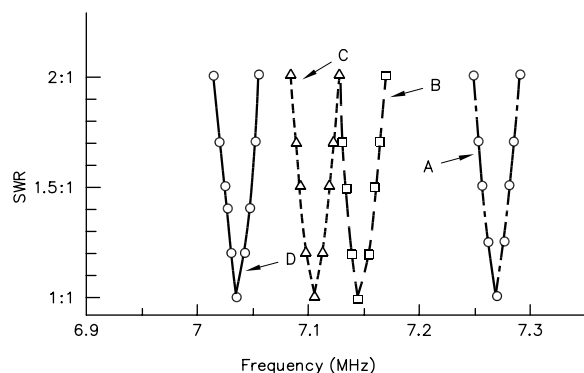
The matching network, using C2/C3, is quite broadband. Once the feed-point matching capacitors ( $C_M$ ) and the retuned coil were adjusted, the minimum SWR was 1:1 at all tap settings on both bands. Thus, the matching arrangement does not require adjustment. If a compromise setting is chosen for the 14-MHz LC tap position to allow both CW and SSB operation on that band, only adjustment of the 7-MHz tap will be required during routine operation. To this end, the plots shown in Fig 34 were obtained. The curves show the 7-MHz resonant frequency as a function of tap position. Also included is a plot showing the effect at 7 MHz of altering the 14-MHz LC tap point.

### Other Considerations

There is no reason why the strategy described here could not be applied to any two bands, as long as the desired



**Fig 32—SWR curves for the antenna in the 14-MHz band. The 7-MHz tap was 12 turns from the top. Curves are shown for the 14-MHz LC tap positioned at  $6\frac{1}{2}$  turns (A) and at  $6\frac{1}{4}$  turns (B). In the last case, moving the 7-MHz tap to  $11\frac{1}{2}$  turns altered the resonant frequency as shown at C.**



**Fig 33—SWR curves for the antenna in the 7-MHz band. The 14-MHz LC tap was  $6\frac{1}{4}$  turns from the top. The 7-MHz tap for curve A was set at  $11\frac{1}{2}$  turns,  $11\frac{3}{4}$  turns for B, 12 turns for C, and  $12\frac{1}{4}$  turns for D.**

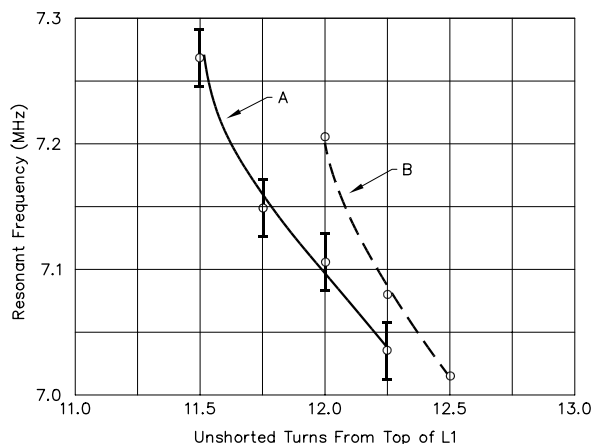
operating frequencies are harmonically related. Other likely candidates would be 3.5-MHz CW/7-MHz CW using a 3.5-MHz coil, 14 MHz/28 MHz using a 14-MHz coil, and 7-MHz SSB/14-MHz SSB. A combination that would probably not work is 3.8-MHz SSB/7-MHz SSB, but it might be worth a try.

The antenna performs very well on the design frequencies. It is too big for routine city use, but it sure makes a great open-highway antenna.

### A MOBILE J ANTENNA FOR 144 MHz

The J antenna is a mechanically modified version of the Zepp (Zeppelin) antenna. It consists of a half-wavelength radiator fed by a quarter-wave matching stub. This antenna exhibits an omnidirectional pattern with little high-angle radiation, but does not require the ground plane that  $\frac{1}{4}$ -wave and  $\frac{5}{8}$ -wave antennas do to work properly. The material in this section was prepared by Domenic Mallozzi, N1DM, and Allan White, W1EYI.

Fig 35 shows two common configurations of the J antenna. Fig 35A shows the shorted-stub version that is usually fed with 200- to 600- $\Omega$  open-wire line. Some have attempted to feed this antenna directly with coax without a balun, and this usually leads to less than optimum results. Among the problems with such a configuration are a lack of reproducibility and heavy coupling with nearby objects. To eliminate these problems, many amateurs have used a 4:1 half-wave balun between the feed point and a coaxial feed line. This simple addition results in an antenna that can be easily reproduced and that does not interact so heavily with surrounding objects. The bottom of the stub may be grounded



**Fig 34—Effect of tap positions on resonant frequency in the 7 MHz band. The 14-MHz LC tap was set at  $6\frac{1}{4}$  turns from the top. At A, each circled dot shows the resonant frequency at which the SWR is 1:1. Bars about each point show the frequency limits at which the SWR is 2:1. The measurements were repeated with the 14-MHz LC tap set at  $6\frac{1}{2}$  turns, yielding the circled points on curve B.**



(for mechanical or other reasons) without impairing the performance of the antenna.

The open-stub-fed J antenna shown in Fig 35B can be connected directly to low-impedance coax lines with good results. The lack of a movable balun (which allows some impedance adjustment) may make this antenna a bit more difficult to adjust for minimum SWR, however.

### The Length Factor

Dr. John S. Belrose, VE2CV, noted in *The Canadian Amateur* that the diameter of the radiating element is important to two characteristics of the antenna—its bandwidth and its physical length. (See Bibliography at the end of this chapter.) As the element diameter is increased, the usable bandwidth increases, while the physical length of the radiating element decreases with respect to the free-space half-wavelength. The increased diameter makes the end effect more pronounced, and also slows the velocity of propagation on the element. These two effects are related to resonant antenna lengths by a factor, “k.” This factor is expressed as a decimal fraction giving the equivalent velocity of propagation on the antenna wire as a function of the ratio of the element diameter to a wavelength. The k factor is discussed at length in Chapter 2.

The length of the radiating element is given by

$$\ell = \frac{5904 \times k}{f} \quad (\text{Eq 25})$$

where

- $\ell$  = length in inches
- f = frequency in MHz
- k = k factor.

The k factor can have a significant effect. For example, if you use a  $5/8$ -inch diameter piece of tubing for the radiator at 144 MHz, the k value is 0.907 (9.3% shorter than a free-space half wavelength).

The J antenna gives excellent results for both mobile and portable work. The mobile described here is similar to

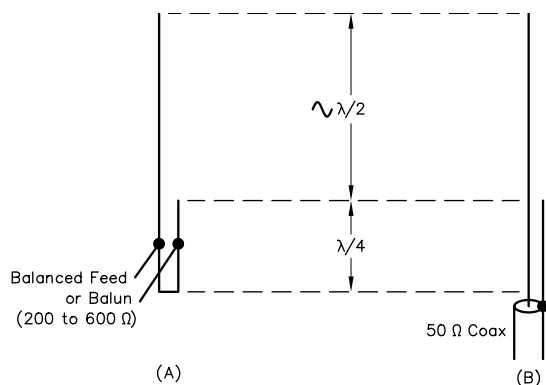


Fig 35—Two configurations of the J antenna.

an antenna described by W. B. Freely, K6HMS, in April 1977 *QST*. This design uses mechanical components that are easier to obtain. As necessary with all mobile antennas, significant attention has been paid to a strong, reliable, mechanical design. It has survived not only three New England winters, but also two summers of 370-mile weekend commutes. During this time, it has maintained consistent electrical performance with no noticeable deterioration.

The mechanical mount to the bumper is a  $2 \times 2$ -inch stainless steel angle iron, 10 inches long. It is secured to the bumper with stainless steel hardware, as shown in Fig 36. A stainless steel  $1/2$ -inch pipe coupling is welded to the left side of the bracket, and an SO-239 connector is mounted at the right side of the bracket. The bracket is mounted to the bumper so a vertical pipe inserted in the coupling will allow the hatchback of the vehicle to be opened with the antenna installed, Fig 37.

A  $1/2$ -inch galvanized iron pipe supports the antenna so the radiating portion of the J is above the vehicle roof line. This pipe goes into a bakelite insulator block, visible in Fig 37. The insulator block also holds the bottom of the stub. This block was first drilled and then split with a band saw, as shown in Fig 38. After splitting, the two portions are weatherproofed with varnish and rejoined with 10-32 stainless hardware. The corners of the insulator are cut to clear the L sections at the shorted end of the stub.

The quarter-wave matching section is made of  $1/4$ -inch type L copper tubing ( $5/16$  inch ID,  $3/8$  inch OD). The short at the bottom of the stub is made from two copper L-shaped sections and a short length of  $1/4$ -inch tubing. Drill a  $1/8$ -inch hole in the bottom of this piece of tubing to drain any water that may enter or condense in the stub.

A  $5/16$ -inch diameter brass rod,  $1\frac{1}{2}$  to 2 inches long, is partially threaded with a  $5/16 \times 24$  thread to accept a Larsen

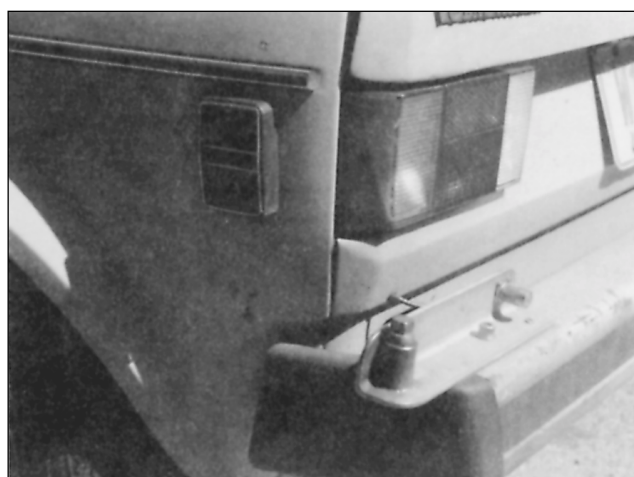


Fig 36—The mount for the mobile J is made from stainless-steel angle stock and secured to the bumper with stainless-steel hardware. Note the  $1/2$ -inch pipe plug and a PL-259 (with a copper disc soldered in its unthreaded end). These protect the mount and connector threads when the antenna is not in use.



**Fig 37—The J antenna, ready for use. Note the bakelite insulator and the method of feed. Tie wraps are used to attach the balun to the mounting block and to hold the coax to the support pipe. Clamps made of flashing copper are used to connect the balun to the J antenna just above the insulating block. The ends of the balun should be weatherproofed.**

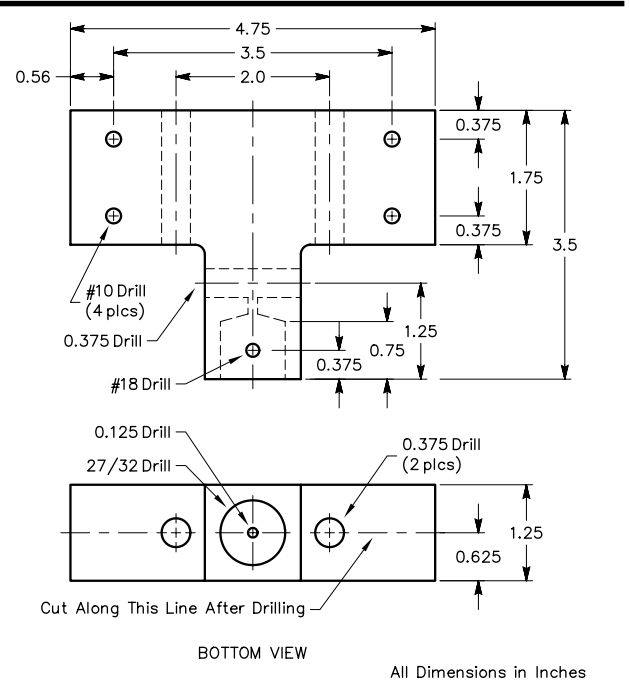
whip connector. This rod is then sweated into one of the legs of the quarter-wave matching section. A 40-inch whip is then inserted into the Larsen connector.

The antenna is fed with 50-Ω coaxial line and a coaxial 4:1 half-wave balun. This balun is described at the end of [Chapter 26](#). As with any VHF antenna, use high-quality coax for the balun. Seal all open cable ends and the rear of the SO-239 connector on the mount with RTV sealant.

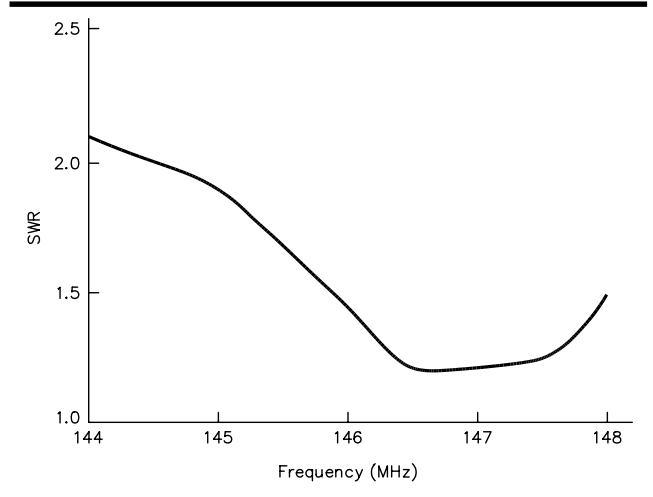
Adjustment is not complicated. Set the whip so that its tip is 41 inches above the open end of the stub, and adjust the balun position for lowest SWR. Then adjust the height of the whip for the lowest SWR at the center frequency you desire. [Fig 39](#) shows the measured SWR of the antenna after adjustments are completed.

### THE SUPER-J MARITIME ANTENNA

This 144-MHz vertical antenna doesn't have stringent grounding requirements and can be made from easy to find parts. The material in this section was prepared by Steve Cerwin, WA5FRF, who developed the Super-J for use on his boat.



**Fig 38—Details of the insulated mounting block. The material is bakelite.**



**Fig 39—Measured SWR of the mobile J antenna.**

Antennas for maritime use must overcome difficulties that other kinds of mobile antennas normally do not encounter. For instance, the transom of a boat is the logical place to mount an antenna. But the transoms of many boats are composed mostly of fiberglass, and they ride some distance out of the water—from several inches to a few feet, depending on the size of the vessel. Because the next best thing to a ground plane (the water surface) is more than an appreciable fraction of a wavelength away at 144 MHz, none of the popular gain-producing antenna designs requiring a counterpoise are suitable. Also, since a water surface does a

good job of assuming the earth's lowest mean elevation (at least on a calm day), anything that can be done to get the radiating part of the antenna up in the air is helpful.

One answer is the venerable J-pole, with an extra in-phase half-wave section added on top—the Super-J antenna. The two vertical half waves fed in phase give outstanding omnidirectional performance for a portable antenna. Also, the J-pole feed arrangement provides the desired insensitivity to height above ground (or water) plus added overall antenna height. Best of all, a  $\frac{1}{4}$ -wave CB whip provides enough material to build the whole driven element of the antenna, with a few inches to spare. The antenna has enough bandwidth to cover the entire 144-MHz band, and affords a measure of lightning protection by being a grounded design.

### Antenna Operation

The antenna is represented schematically in **Fig 40**. The classic J-pole antenna is the lower portion shown between points A and C. The half-wave section between points B and C does most of the radiating. The added half-wave section of the Super-J version is shown between points C and E. The side-by-side quarter-wave elements between points A and B comprise the J feed arrangement.

At first glance, counterproductive currents in the J section between points A and B may seem a waste of element material, but it is through this arrangement that the antenna is able to perform well in the absence of a good ground. The two halves of the J feed arrangement, side by side, provide a loading mechanism regardless of whether or not a ground plane is present.

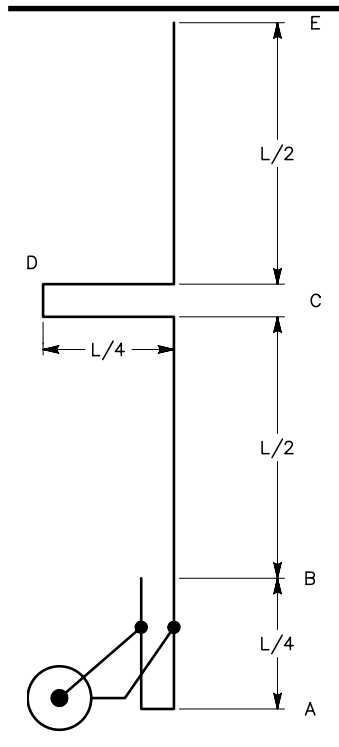
The radiation resistance of any antenna fluctuates as a function of height above ground, but the magnitude of this effect is small compared to the wildly changing impedance encountered when the distance from a ground plane element to its counterpoise is varied. Also, the J section adds  $\frac{1}{4}$  wavelength of antenna height, reducing the effect of ground height variations even further. Reducing ground-height sensitivity is particularly useful in maritime operation on those days when the water is rough.

The gain afforded by doubling the aperture of a J-pole with the extra half-wave section can be realized only if the added section is excited in phase with the half-wave element B-C. This is accomplished in the Super-J in a conventional manner, through the use of the quarter-wave phasing stub shown between C and D.

### Construction and Adjustment

The completed Super-J is shown in **Fig 41**. Details of the individual parts are given in **Fig 42**. The driven element can be liberated from a quarter-wave CB whip antenna and cut to the dimensions shown. All other metal stock can be obtained from metal supply houses or machine shops. Metal may even be scrounged for little or nothing as scraps or remnants, as were the parts for the antenna shown here.

The center insulator and the two J stub spacers are made of  $\frac{1}{2}$ -inch fiberglass and stainless steel stock, and the end caps are bonded to the insulator sections with epoxy. If you



**Fig 40—Schematic representation of the Super-J maritime antenna. The radiating section is two half waves in phase.**



don't have access to a lathe to make the end caps, a simpler one-piece insulator design of wood or fiberglass could be used. However, keep in mind that good electrical connections must be maintained at all joints, and strength is a consideration for the center insulator.

The quarter-wave phasing stub is made of  $\frac{1}{8}$ -inch stainless steel tubing, **Fig 43**. The line comprising this stub is bent in a semicircular arc to narrow the vertical profile and to keep the weight distribution balanced. This makes for an attractive appearance and keeps the antenna from leaning to one side.

The bottom shorting bar and base mounting plate

**Fig 41—Andy and the assembled Super-J antenna.**

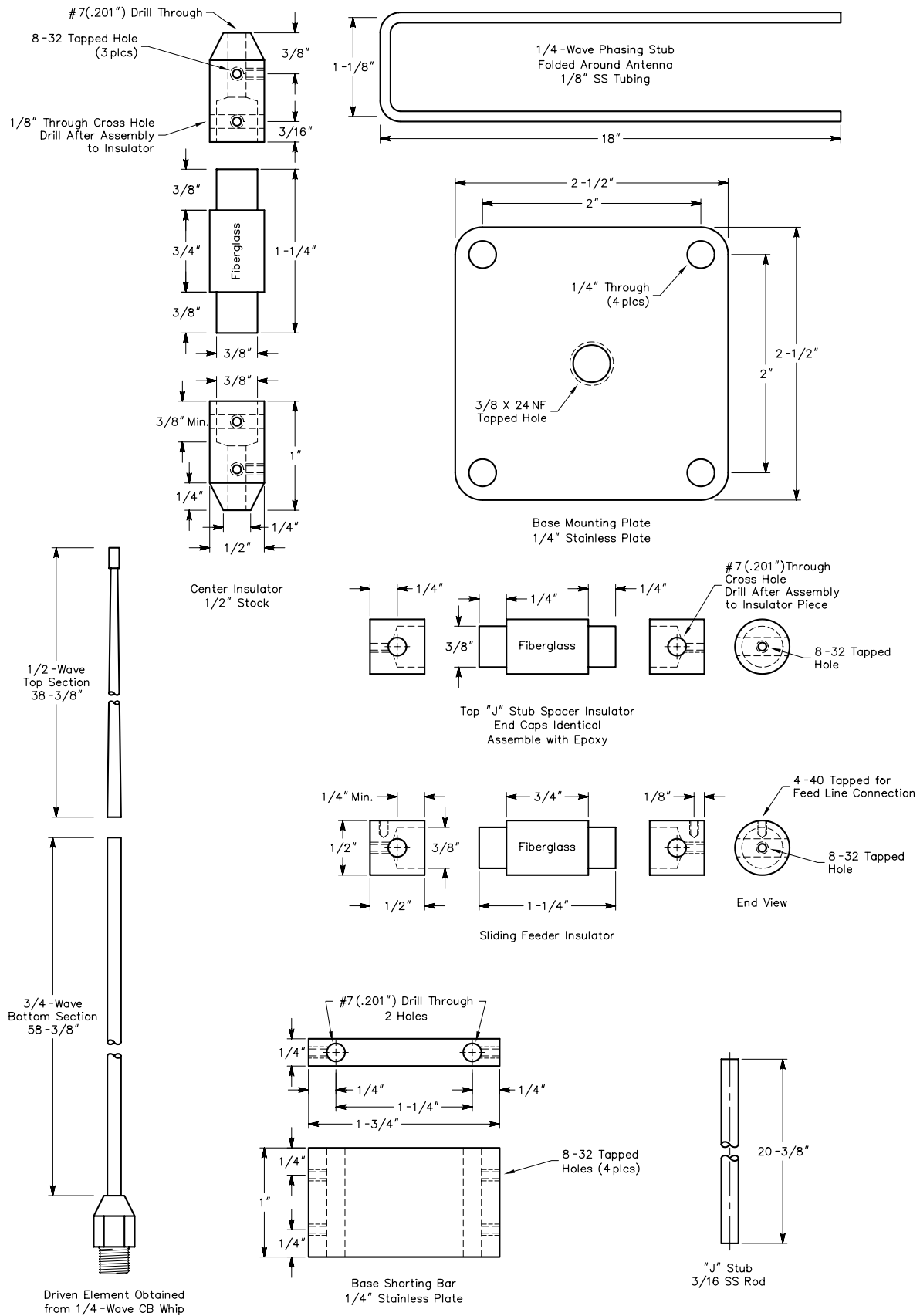


Fig 42—Details of parts used in the construction of the 144-MHz Super-J. Not to scale.

are made of  $1/4$ -inch stainless steel plate, shown in **Fig 44**. The J stub is made of  $3/16$ -inch stainless-steel rod stock. The RF connector may be mounted on the shorting bar as shown, and connected to the adjustable slider with a short section of coaxial cable. RTV sealant should be used at the cable ends to keep out moisture. The all-stainless construction looks nice and weathers well in maritime mobile applications.

The antenna should work well over the whole 144-MHz band if cut to the dimensions shown. The only tuning required is adjustment of the sliding feed point for minimum SWR in the center of the band segment you use most. Setting the slider  $2^{13}/16$  inch above the top of the shorting bar gave the best match for this antenna and may be used for a starting point. Four turns of coax made into a coil at the feed point or a ferrite-sleeve balun act as a common-mode choke balun to ensure satisfactory performance.

### Performance

Initial tests of the Super-J were performed in portable use and were satisfactory, if not exciting. **Fig 45** shows the Super-J mounted on a wooden mast at a portable site. Simplex communication with a station 40 miles away with a 10-W mobile rig was full quieting both ways. Stations were worked through distant repeaters that were thought inaccessible from this location.

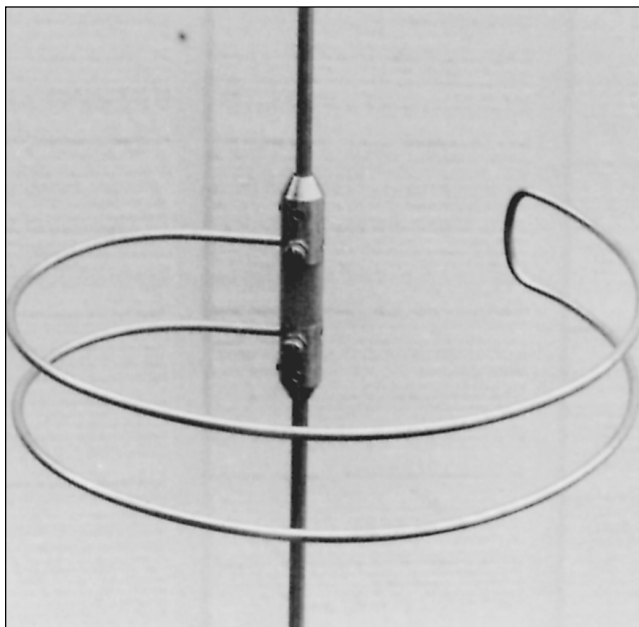
Comparative tests between the Super-J and a commercial  $5/8$ -wave antenna mounted on the car showed the Super-J to give superior performance, even when the Super-J was lowered to the same height as the car roof. The mast shown in Fig 45 was made from two 8-foot lengths of

$1 \times 2$ -inch pine. (The two mast sections and the Super-J can be easily transported in most vehicles.)

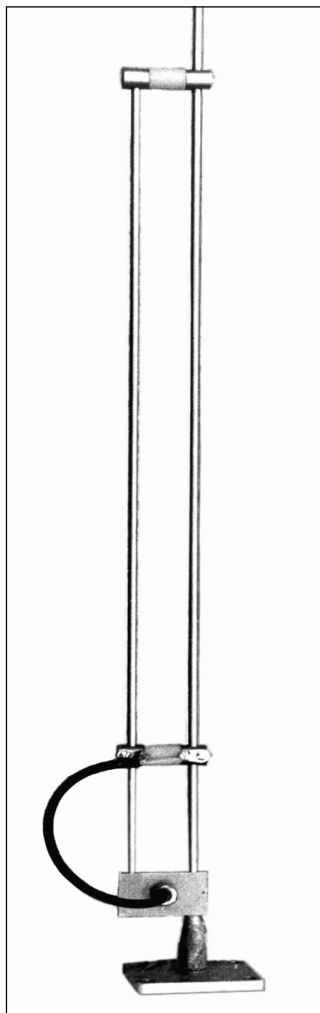
The Super-J offers a gain of about 6 dB over a quarter-wave whip and around 3 dB over a  $5/8$ -wave antenna. Actual performance, especially under less-than-ideal or variable ground conditions, is substantially better than other vertical antennas operated under the same conditions. The freedom from ground-plane radials proves to be a real benefit in maritime mobile operation, especially for those passengers in the back of the boat with sensitive ribs!

### A TOP-LOADED 144-MHz MOBILE ANTENNA

Earlier in this chapter, the merits of various loading schemes for shortened whip antennas were discussed. Quite naturally, one might be considering HF mobile operation for the application of those techniques. But the principles may be applied at any frequency. **Fig 46** shows a 144-MHz antenna that is both top and center loaded. This antenna is suitable for both mobile and portable operation, being



**Fig 43**—A close-up look at the  $1/4$ - $\lambda$  phasing section of the Super-J. The insulator fitting is made of stainless-steel end caps and fiberglass rod.



**Fig 44**—The bottom shorting bar and base mounting plate assembly.



**Fig 45**—The Super-J in portable use at a field site.

intended for use on a handheld transceiver. This antenna was devised by Don Johnson, W6AAQ, and Bruce Brown, W6TWW.

A combination of top and center loading offers improved efficiency over continuously loaded antennas such as the “stubby” pictured at the beginning of this chapter. This antenna also offers low construction cost. The only materials needed are a length of stiff wire and a scrap of circuit-board material, in addition to the appropriate connector.

### Construction

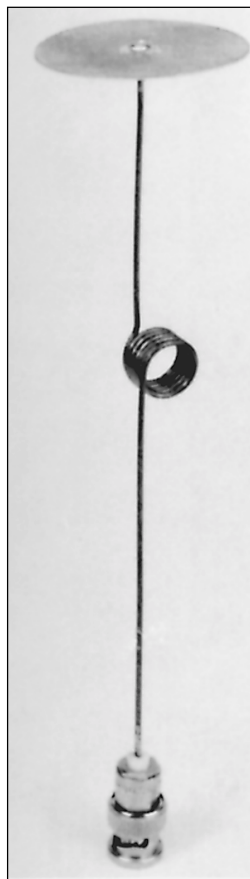
The entire whip section with above-center loading coil is made of one continuous length of material. An 18-inch length of brazing rod or #14 Copperweld wire is suitable.

In the antenna pictured in Fig 46, the top loading disk was cut from a scrap of circuit-board material, but flashing copper or sheet brass stock could be used instead. Aluminum is not recommended.

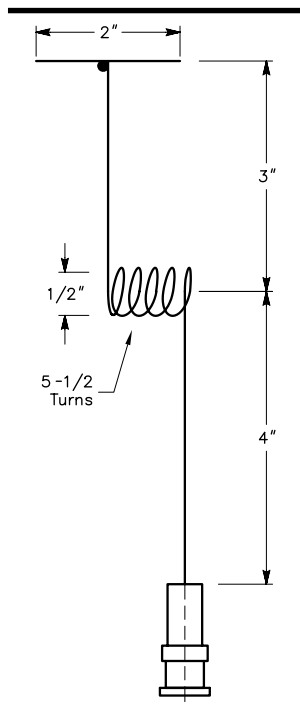
The dimensions of the antenna are given in Fig 47. First wind the center loading coil. Use a 1/2-inch bolt, wood dowel, or other cylindrical object for a coil form. Begin winding at a point 3 inches from one end of the wire, and wrap the wire tightly around the coil form. Wind 5 1/2 turns, with just enough space between turns so they don't touch.

Remove the coil from the form. Next, determine the length necessary to insert the wire into the connector you'll be using. Cut the long end of the wire to this length plus 4 inches, measured from the center of the coil. Solder the wire to the center pin and assemble the connector. A tight-fitting sleeve made of Teflon or Plexiglas rod may be used to support and insulate the antenna wire inside the shell. An alternative is to fill the shell with epoxy cement, and allow the cement to set while the wire is held centered in the shell.

The top loading disk may be circular, cut with a hole saw. A circular disk is not required, however—it may be of any shape. Just remember that with a larger disk, less coil inductance will be required, and vice versa. Drill a hole at the center of the disk for



**Fig 46—This 144-MHz antenna uses a combination of top and center loading. It offers low construction cost and improved efficiency over continuously loaded rubber-duddy antennas.**



**Fig 47—Dimensions for the top-loaded 144-MHz antenna. See text regarding coil length.**

mounting it to the wire. For a more rugged antenna, reinforce the hole with a brass eyelet. Solder the disk in place at the top of the antenna, and construction is completed.

### Tune-Up

Adjustment consists of spreading the coil turns for the correct amount of inductance. Do this at the center frequency of the range you'll normally be using. Optimum inductance is determined with the aid of a field strength

meter at a distance of 10 or 15 feet.

Attach the antenna to a handheld transceiver operating on low power, and take a field-strength reading. With the transmitter turned off, spread the coil turns slightly, and then take another reading. By experiment, spread or compress the coil turns for the maximum field-strength reading. Very little adjustment should be required. There is one precaution, however. You must keep your body, arms, legs, and head in the same relative position for each field-strength measurement. It is suggested that the transceiver be placed on a nonmetal table and operated at arm's length for these checks.

Once the maximum field-strength reading is obtained, adjustments are completed. With this antenna in operation, you'll likely find it possible to access repeaters that are difficult to reach with other shortened antennas. W6AAQ reports that in distant areas his antenna even outperforms a  $5/8\lambda$  vertical.

### VHF QUARTER-WAVELENGTH VERTICAL

Ideally, a VHF vertical antenna should be installed over a perfectly flat reflector to assure uniform omnidirectional radiation. This suggests that the center of the automobile roof is the best place to mount it for mobile use. Alternatively, the flat portion of the trunk deck can be used, but will result in a directional pattern because of car-body obstruction.

Fig 48 illustrates how a Millen high-voltage connector can be used as a roof mount for a VHF whip. The hole in the roof can be made over the dome light, thus providing accessibility through the upholstery. RG-59 and the 1/4-wave matching section, L (Fig 48C), can be routed between the car roof and the ceiling upholstery and brought into the trunk compartment, or down to the dashboard of the car. Instead

of a Millen connector, some operators install an SO-239 coax connector on the roof for mounting the whip. The method is similar to that shown in Fig 48.

It has been established that in general,  $1/4\text{-}\lambda$  vertical antennas for mobile repeater work are not as effective as  $5/8\text{-}\lambda$  verticals are. With a  $5/8\text{-}\lambda$  antenna, more of the transmitted signal is directed at a low wave angle, toward the horizon, offering a gain of about 3 dB over the  $1/4\text{-}\lambda$  vertical. However, in areas where the repeater is located nearby on a very high hill or a mountain top, the  $1/4\text{-}\lambda$  antenna will usually offer more reliable performance than a  $5/8\text{-}\lambda$  antenna. This is because there is more power in the lobe of the  $1/4\text{-}\lambda$  vertical at higher angles.

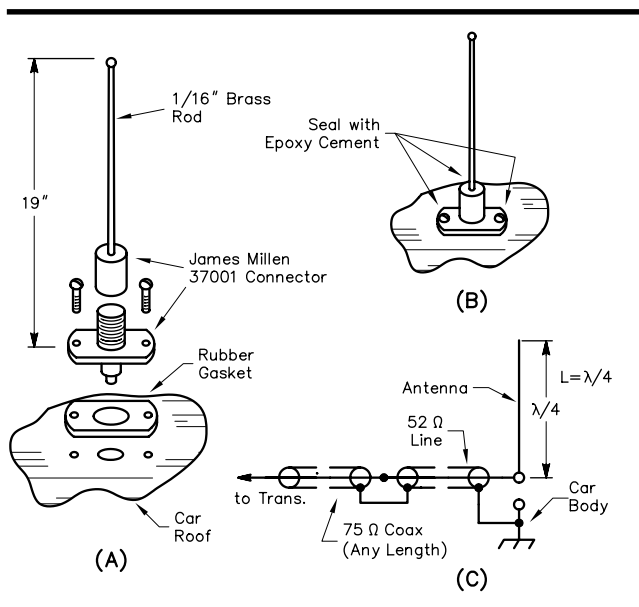
### 144-MHz 5/8-WAVELENGTH VERTICAL

Perhaps the most popular antenna for 144-MHz FM mobile and fixed-station use is the  $5/8\text{-}\lambda$  wavelength vertical. As compared to a  $1/4\text{-}\lambda$  wavelength vertical, it has 3 dB gain.

This antenna is suitable for mobile or fixed-station use because it is small, omnidirectional, and can be used with radials or a solid-plane ground (such as a car body). If radials are used, they need be only  $1/4$  wavelength long.

### Construction

The antenna shown here is made from low-cost materials. Fig 49 shows the base coil and aluminum mounting plate. The coil form is a piece of low-loss solid rod, such a Plexiglas or phenolic. The dimensions for this



**Fig 48**—At A and B, an illustration of how a quarter-wavelength vertical antenna can be mounted on a car roof. The whip section should be soldered into the cap portion of the connector and then screwed into the base socket. This arrangement allows for the removal of the antenna when desired. Epoxy cement should be used at the two mounting screws to prevent the entry of moisture through the screw holes. Diagram C is discussed in the text.

and other parts of the antenna are given in Fig 50. A length of brazing rod is used as the whip section.

The whip should be 47 inches long. However, brazing rod comes in standard 36-inch lengths, so if used, it is necessary to solder an 11-inch extension to the top of the whip. A piece of #10 copper wire will suffice. Alternatively, a stainless-steel rod can be purchased to make a 47-inch whip. Shops that sell CB antennas should have such rods for replacement purposes on base-loaded antennas. The limitation one can expect with brazing rod is the relative fragility of the material, especially when the threads are cut for screwing the rod into the base coil form. Excessive stress can cause the rod to break where it enters the form. The problem is complicated somewhat in this design because a spring is not used at the antenna mounting point. Builders of this antenna can find all kinds of solutions to the problems just outlined by changing the physical design and using different materials when constructing the antenna. The main purpose of this description is to provide dimensions and tune-up information.

The aluminum mounting bracket must be shaped to fit the car with which it will be used. The bracket can be used to effect a no-holes mount with respect to the exterior portion of the car body. The inner lip of the vehicle trunk (or hood) can be the point where the bracket is attached by means of no. 6 or no. 8 sheet-metal screws. The remainder of the bracket is bent so that when the trunk lid or car hood is raised and lowered, there is no contact between the bracket and the moving part. Details of the mounting unit are given in Fig 50B. A 14-gauge metal (or thicker) is recommended for rigidity.

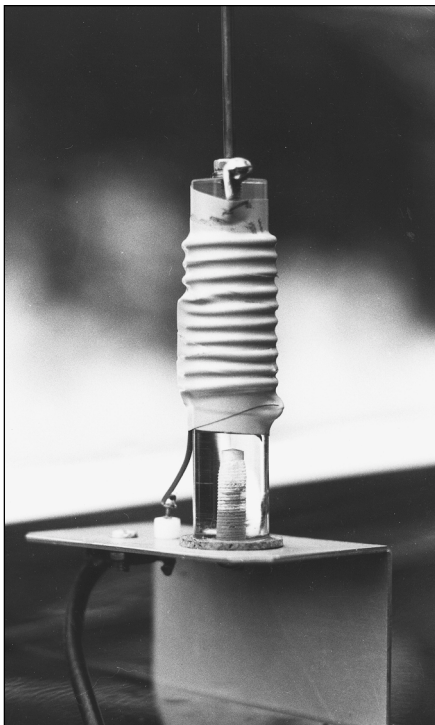
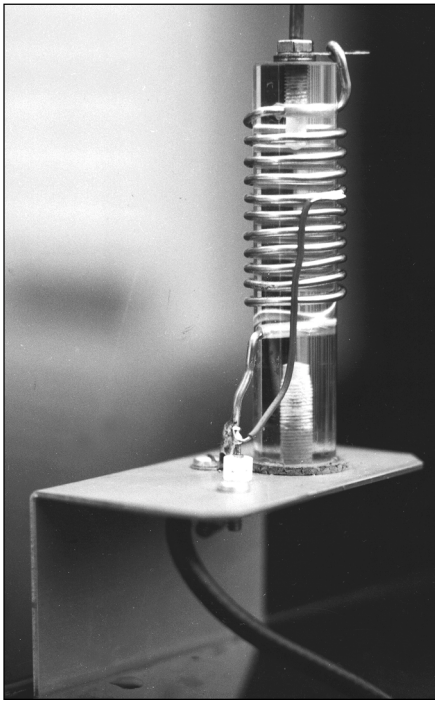
Wind  $10\frac{1}{2}$  turns of #10 or #12 copper wire on the  $3/4$ -inch diameter coil form. The tap on L1 is placed approximately four turns below the whip end. A secure solder joint is imperative.

### Tune-Up

After the antenna has been mounted on the vehicle, connect an SWR indicator in the 50- $\Omega$  transmission line. Key the 144-MHz transmitter and experiment with the coil tap placement. If the whip section is 47 inches long, an SWR of 1:1 can be obtained when the tap is at the right location. As an alternative method of adjustment, place the tap at four turns from the top of L1, make the whip 50 inches long, and trim the whip length until an SWR of 1:1 occurs. Keep the antenna well away from other objects during tune-up, as they may detune the antenna and yield false adjustments for a match.

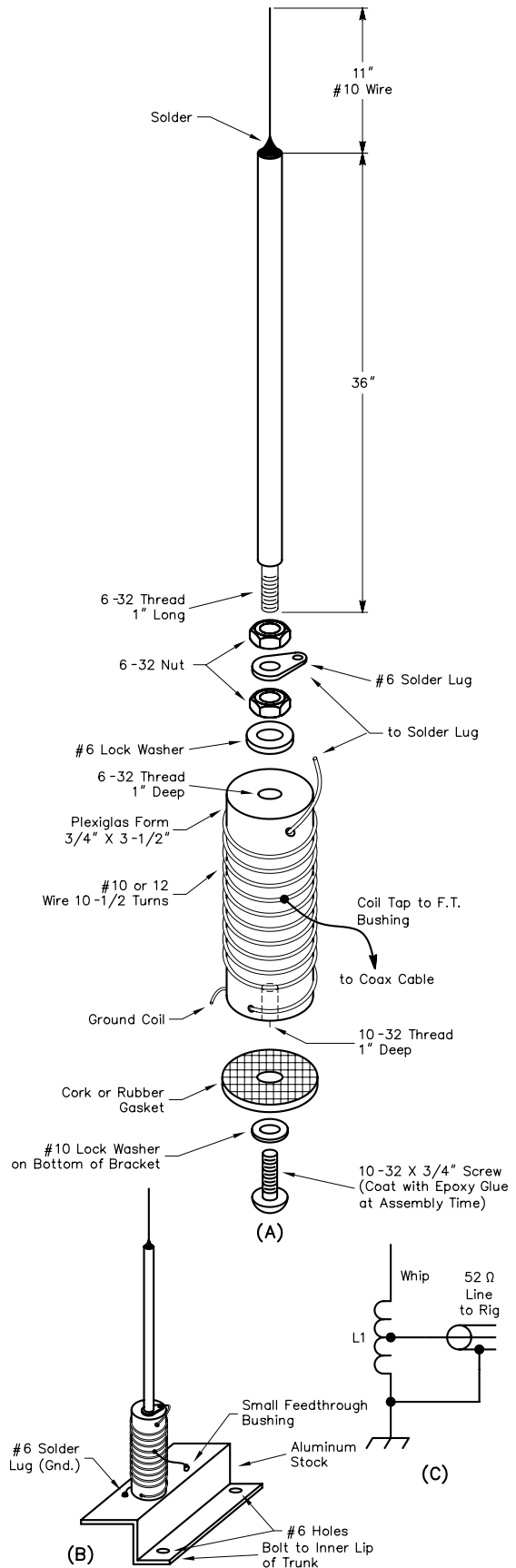
### A 5/8-WAVELENGTH 220-MHz MOBILE ANTENNA

The antenna shown in Figs 51 and 52 was developed to fill the gap between a homemade  $1/4\text{-}\lambda$  mobile antenna and a commercially made  $5/8\text{-}\lambda$  model. While antennas can be made by modifying CB models, that presents the problem of cost in acquiring the original antenna. The major cost in this setup is the whip portion. This can be any tempered rod that will spring easily.



**Fig 49**—At top, a photograph of the  $\frac{5}{8}\lambda$  vertical base section. The matching coil is affixed to an aluminum bracket that screws onto the inner lip of the car trunk. Above, the completed assembly. The coil has been wrapped with vinyl electrical tape to keep out dirt and moisture.

**Fig 50**—Structural details for the 2-meter  $\frac{5}{8}\lambda$  antenna are provided at A. The mounting bracket is shown at B and the equivalent circuit is given at C.





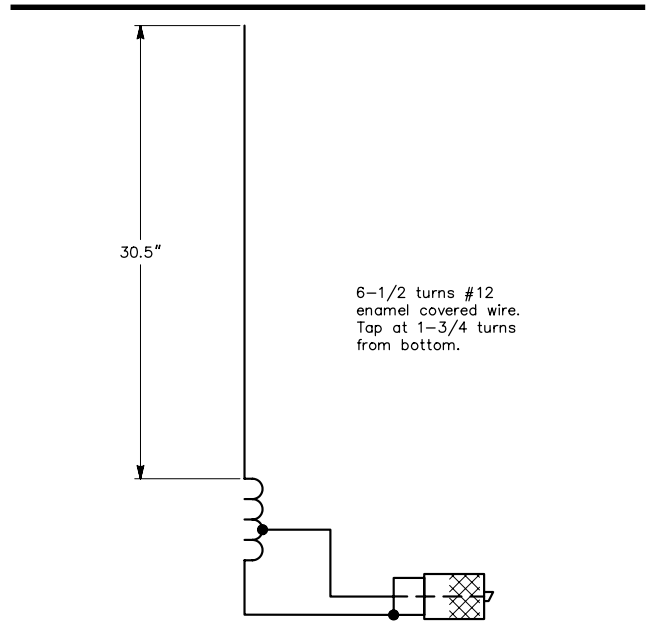


**Fig 51—The 220-MHz  $\frac{5}{8}\lambda$  mobile antenna. The coil turns are spaced over a distance of 1 inch, and the bottom end of the coil is soldered to the coax connector.**

### Construction

The base insulator portion is made of  $\frac{1}{2}$ -inch Plexiglas rod. A few minutes' work on a lathe is sufficient to shape and drill the rod. (The innovative builder can use an electric drill and a file for the lathe work.) The bottom  $\frac{1}{2}$  inch of the rod is turned down to a diameter of  $\frac{3}{8}$  inch. This portion will now fit into a PL-259 UHF connector. A  $\frac{1}{8}$ -inch diameter hole is drilled through the center of the rod. This hole will hold the wires that make the connections between the center conductor of the connector and the coil tap. The connection between the whip and the top of the coil is also run through this opening. A stud is force-fitted into the top of the Plexiglas rod. This allows for removal of the whip from the insulator.

The coil should be initially wound on a form slightly



**Fig 52—Diagram of the 220-MHz mobile antenna.**

smaller than the base insulator. When the coil is transferred to the Plexiglas rod, it will keep its shape and will not readily move. After the tap point has been determined, a longitudinal hole is drilled into the center of the rod. A #22 wire can then be inserted through the center of the insulator into the connector. This method is also used to attach the whip to the top of the coil. After the whip has been fully assembled, a coating of epoxy cement is applied. This seals the entire assembly and provides some additional strength. During a full winter's use there was no sign of cracking or other mechanical failure. The adjustment procedure is the same as for the 144-MHz version described previously.

# HF ANTENNAS FOR SAILBOATS

This material was contributed by Rudy Severns, N6LF. Many of the antenna ideas appearing earlier in this chapter can be applied to sailboats. However, the presence of the mast and the rigging, plus the prevalence of non-conducting fiberglass hulls complicates the issue. There are many possibilities for antennas aboard sailboats. This includes both permanently installed antennas and antennas that can be hoisted for temporary use at anchor:

## 1. *Permanent*

Commercial or home-brew automobile-type verticals  
Backstay verticals and slopers  
Shunt feed of uninsulated rigging

## 2. *Temporary*

Sloping dipoles  
Inverted V's  
Yagis

You should remember some basic facts of life on a sailboat:

- 1) On most boats the spars, standing rigging and some running rigging will be conductors. Stainless steel wire is usually used for the rigging and aluminum for the spars.
- 2) Topping lifts, running backstays and jackstays all may be made of conducting materials and may often change position while the boat is underway. This changes the configuration of the rigging and may affect radiation patterns and feed-point impedances.
- 3) Shipboard antennas will always be close to the mast and rigging, in terms of electrical wavelength. Some antennas may in fact be part of the rigging.
- 4) The feed-point impedance and radiation pattern can be strongly influenced by the presence of the rigging.
- 5) Because of the close proximity, the rigging is an integral part of the antenna and should be viewed as such.
- 6) The behavior of a given antenna will depend of the details of the rigging on a particular vessel. The performance of a given antenna can vary widely on different boats, due to differences in dimensions and arrangement of the rigging.
- 7) Even though you may be floating on a sea of salt water, grounding still requires careful attention!

## ANTENNA MODELING

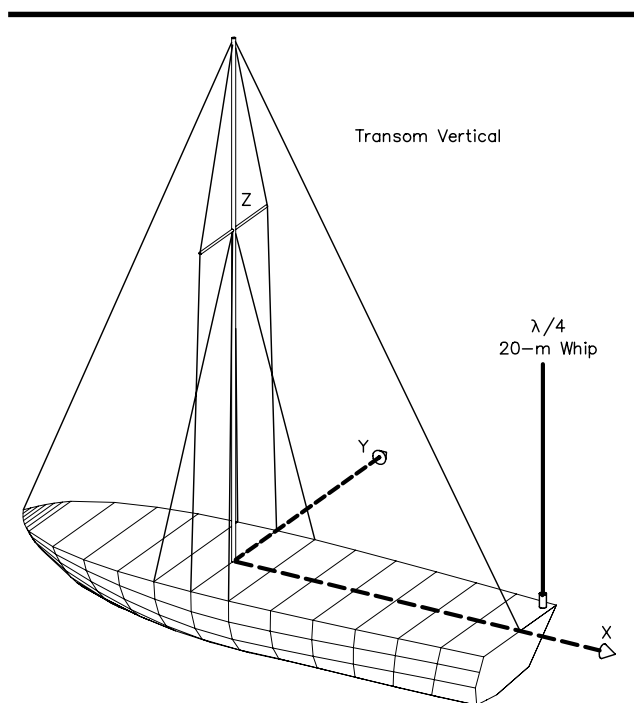
Because of the strong interaction between the rigging and the antenna, accurate prediction of radiation patterns and a reasonable guess at expected feed-point impedance requires that you model both the antenna and the rigging. Unless you do accurately model the system, considerable cut-and-try may be needed. This can be expensive when it has to be done in  $1 \times 19$  stainless steel wire with \$300 swaged insulator fittings!

In fact, when your antenna is going to be part of standing

rigging, it's a very good idea to try your designs out at the dock. You could temporarily use Copperweld wire and inexpensive insulators in place of the stainless rigging wire and the expensive insulators. This approach can save a good deal of money and aggravation. A wide variety of modeling programs are available and can be very helpful in designing a new antenna but they have to be used with some caution:

- 1) The rigging will have many small intersection angles and radically different conductor diameters, this can cause problems for *NEC* and *MININEC* programs.
- 2) You must usually taper the segment lengths near the junctions. This is done automatically in programs like *ELNEC* and *EZNEC*.
- 3) It is usually necessary to use one wire size for the mast, spars and rigging. Some improvement in accuracy can be obtained by modeling the mast as a cage of 3 or 4 wires.

The predicted radiation patterns will be quite good but the feed-point impedance predictions should be viewed as preliminary. Some final adjustment will usually be required. Because of the wide variation between boats, even those of the same class, each new installation is unique and should be analyzed separately.



**Fig 53—An example of a 20-meter  $\lambda/4$  whip mounted on the transom. A local ground system must also be provided, as described in the section on grounding.**

## A SAFETY NOTE

Ungrounded rigging endpoints near deck level can have high RF potentials on them when you transmit. For example, the shrouds on a fiberglass boat connect to chainplates that are bolted to the hull, but are not grounded. These can inflict painful RF burns on the unwary, even while operating at low power! As a general rule all rigging, spars and lifelines near deck level should be grounded. This also makes good sense for lightning protection. For a backstay antenna with its feed point near deck level, a sleeve of heavy wall PVC pipe can be placed over the lower end of the stay as a protective shield.

## TRANSOM AND MASTHEAD MOUNTED VERTICALS

A very common antenna for boats is a vertical, either a short mobile antenna or a full  $\lambda/4$ , placed on the transom, as shown in Fig 53. Note that in this example the antenna is mounted off to one side—it could also be mounted in the center of the transom. The 20-meter radiation pattern for

this antenna as shown in Fig 54. Unlike a free standing vertical, this antenna doesn't have an omnidirectional pattern. It is asymmetrical, with a front-to-back ratio of about 13 dB. Further, the angle for maximum gain is offset in the direction the antenna is placed on the transom.

This is a very good example of the profound effect the rigging can have on any antenna used on board a sailboat. Not only is the pattern affected but the feed-point impedance will be reduced from a nominal  $36 \Omega$  to 25 to  $30 \Omega$ .

The directive gain can be useful—if you point the boat in the right direction! Usually, however, a more uniform omnidirectional pattern is more desirable. It is tempting to suggest putting the vertical at the masthead, perhaps using a 6-foot loaded automobile whip, with the mast and rigging acting as a ground plane. Fig 55 shows such a system. Unfortunately, this usually doesn't work very well because the overall height of the mast and antenna will very likely be  $> 5/8 \lambda$ . This will result in high-angle lobes, as shown in Fig 56. Depending on the mast height, this idea may work reasonably well on 40 or 80 meters, but you will still be faced with severe mechanical stress due to magnified motion at the masthead in rough sea. The masthead is usually reserved to VHF antennas, with their own radial ground plane.

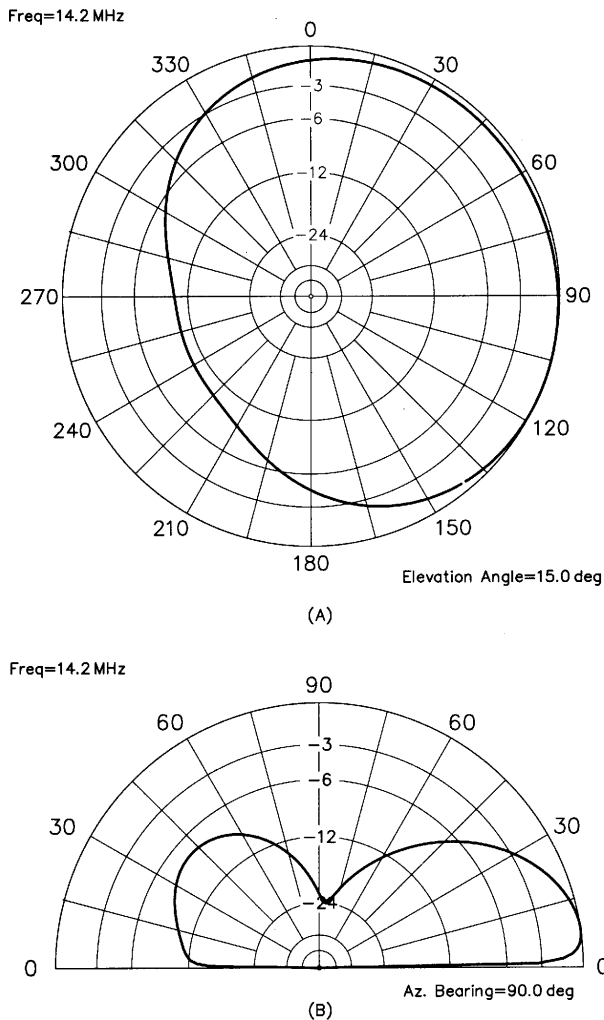


Fig 54—Typical radiation pattern for the  $\lambda/4$  transom mounted whip in Fig 53.

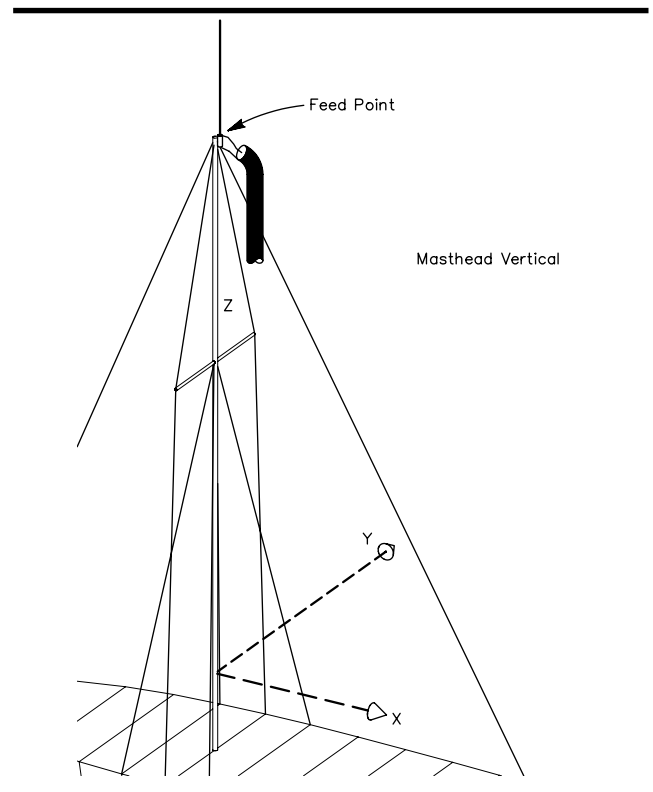
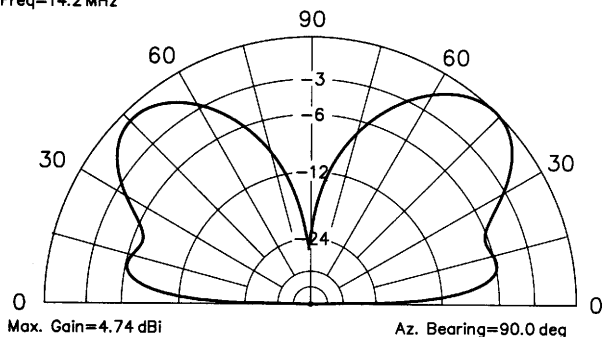


Fig 55—A whip mounted at the masthead. The feed line is fed back down the mast either inside or outside. The base of the mast and the rigging is assumed to be properly grounded.

Freq=14.2 MHz

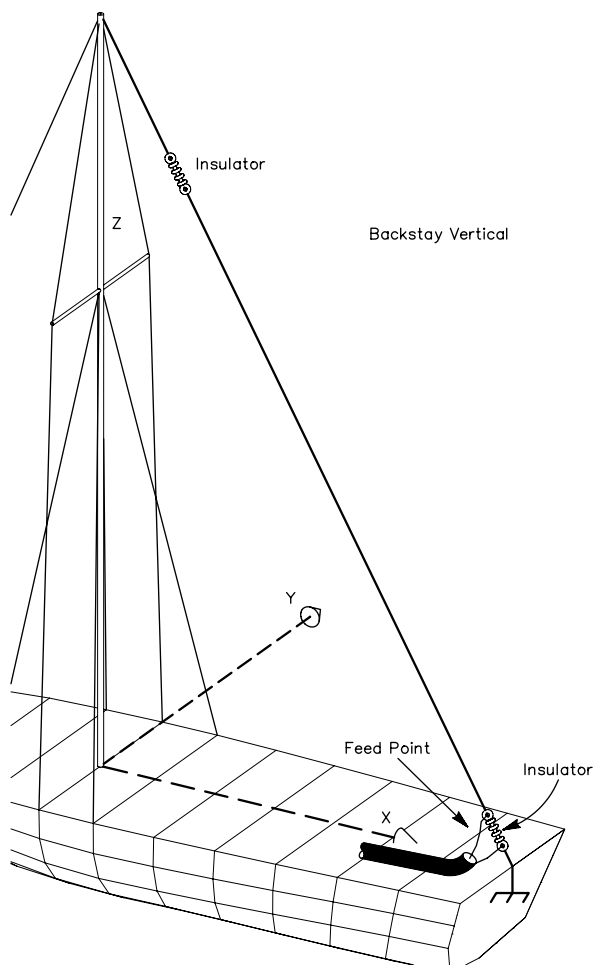


**Fig 56**—Typical radiation pattern for a masthead-mounted vertical. The multiple vertical lobes are due to the fact the antenna is higher than  $\lambda/2$ .

## THE BACKSTAY VERTICAL

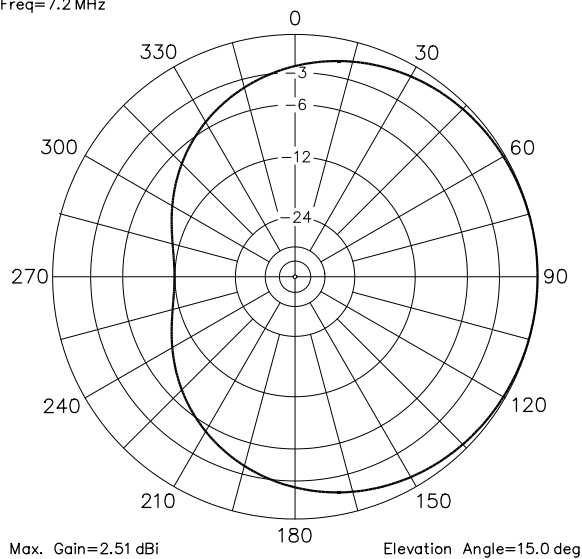
A portion of the backstay can be insulated and used as a vertical as shown in **Fig 57**. The length of the insulated section will be  $\lambda/4$  on the lowest band of interest. Typically, due to the loading effect of the rest of the rigging, the resonant length of the insulated section will be shorter than the classic  $234/f$  (MHz) relation, although it can in some case actually be longer. Either modeling or trial adjustment can be used to determine the actual length needed. On a typical 35 to 40-foot sailboat, the lowest band for  $\lambda/4$  resonance will be 40 meters due to the limited length of the backstay. Examples of the radiation patterns on several bands for such an antenna are given in **Figs 58, 59** and **60**.

The pattern is again quite directional due to the presence of the mast and rigging. On 15 meters, where the antenna is approximately  $3/4 \lambda$ , higher angle lobes appear. On 40 and 15 meters, the feed point is near a current maximum and is in the range of 30 to 50  $\Omega$ . On 20 meters,



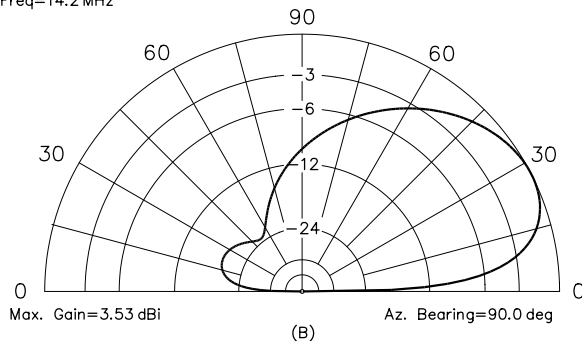
**Fig 57**—An example of a backstay vertical. A local ground point must be established on the transom next to the base of the backstay.

Freq=7.2 MHz

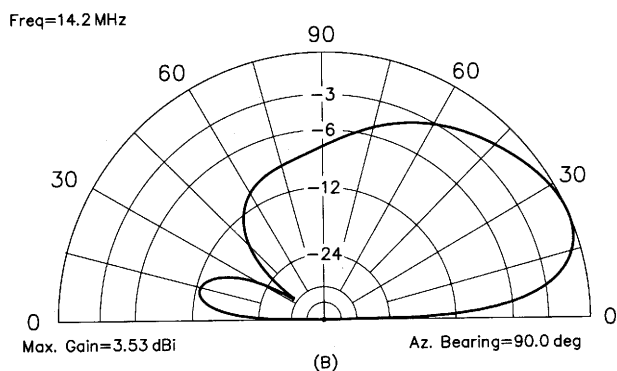
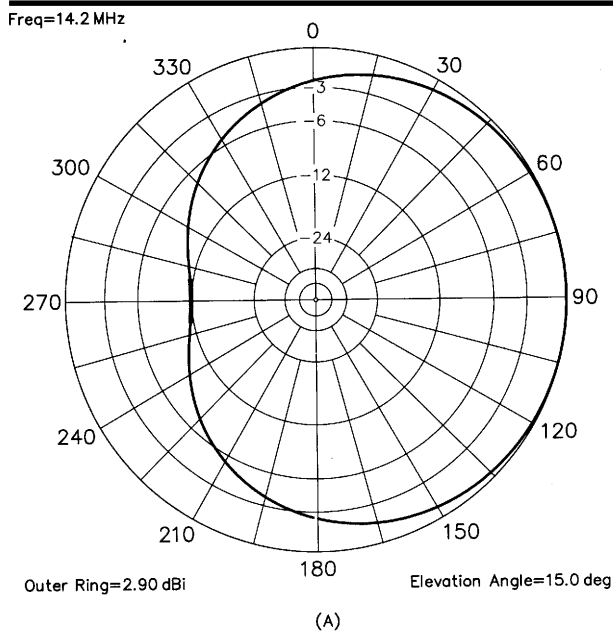


(A)

Freq=14.2 MHz



**Fig 58**—Typical radiation patterns on 40 meters for the backstay vertical in Fig 57.

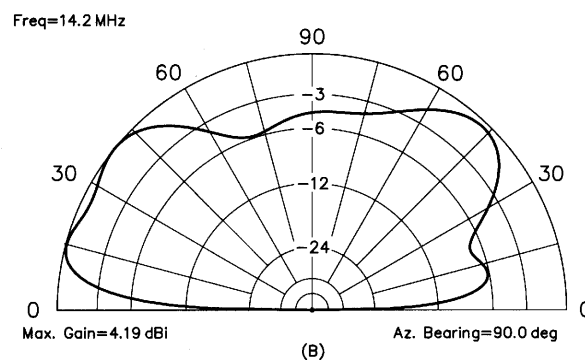
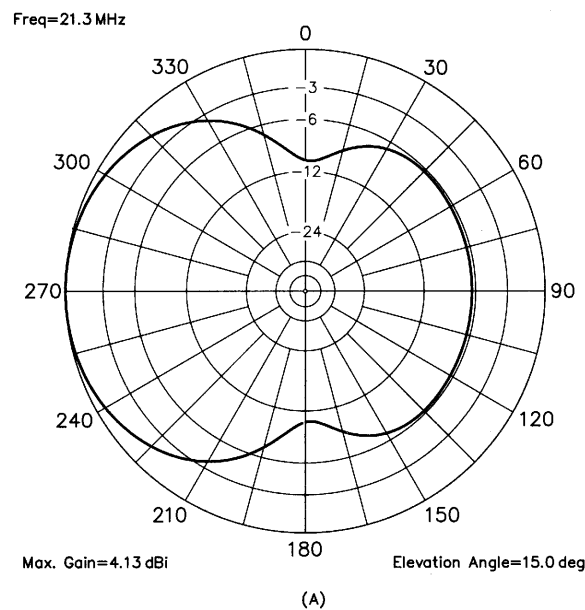


**Fig 59—Typical radiation patterns on 20 meters for the backstay vertical in Fig 57.**

however, the feed point is a very high impedance because the antenna is near  $\lambda/2$  resonance. One way to get around this problem for multiband use is to make the antenna longer than  $\lambda/4$  on the lowest band. If the lowest band is 40 meters then on 20 meters the feed-point impedance will be much lower. This antenna is non-resonant on any of the bands but can be conveniently fed with a tuner because the feed-point impedances are within the range of commonly available commercial tuners. Tuners specifically intended for marine applications frequently can accommodate very high input impedances, but they tend to be quite expensive.

The sensitivity of the radiation pattern to small details of the mast and rigging is illustrated in Fig 61. This is the same antenna as shown in Fig 57 with the exception that the forestay is assumed to be ungrounded. In this particular example, ungrounding the forestay drastically increases the front-to-back ratio. With slightly different dimensions, however, the pattern could have changed in other ways.

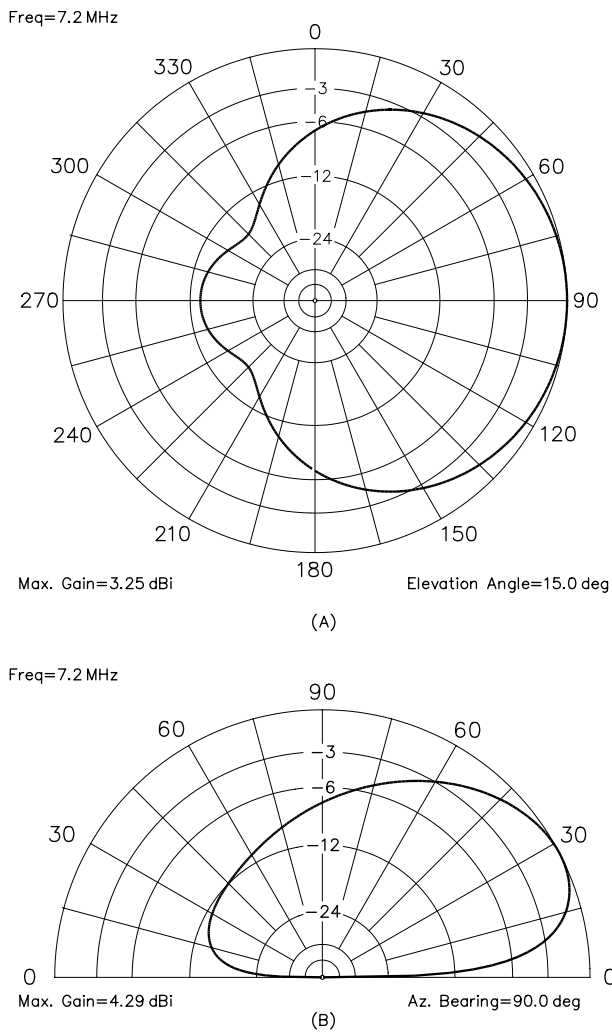
High-quality insulators for rigging wire can be quite



**Fig 60—Typical radiation patterns on 15 meters for the backstay vertical in Fig 57.**

expensive and represent a potential weak point—if they fail the mast may come down. It is not absolutely necessary to use two insulators in a backstay vertical. As shown in Fig 62, the upper insulator may be omitted. The radiation patterns are shown in Figs 63 and 64. In this case the pattern is actually more symmetrical than it was with an upper insulator—but this may not hold true for other rigging dimensions. The feed point does not have to be at the bottom of the backstay. As indicated in Fig 62, the feed point can be moved up into the backstay to achieve a better match or a more desirable feed-point impedance variation with frequency. In that case, the center of the coaxial feed line is connected to the upper section and the shield to the lower section. The cable is then taped to the lower portion of the backstay.

If single-band operation is all you want, even the lower insulator can be omitted by using shunt feed. A gamma match would be quite effective for this purpose, as discussed in Chapter 6 when driving a grounded tower.



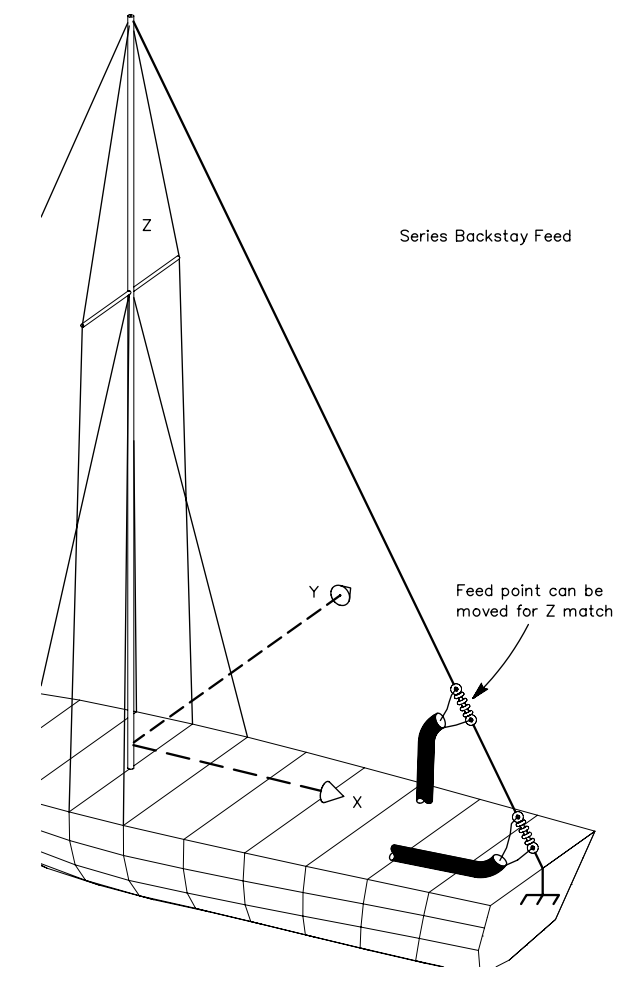
**Fig 61—The effect of ungrounding the forestay on the radiation pattern. This is for 40-meter operation.**

### A 40-METER BACKSTAY HALF SLOPER

A half-sloper antenna can be incorporated into the backstay, as shown in **Fig 65**. This will behave very much the same as the slopers described in **Chapter 6**. The advantage of this antenna for a sailboat installation is that you don't need to create a good ground connection at the stern, as you would have to do for a transom-mounted vertical or the backstay vertical just described. This may be more convenient. The mast, shrouds and stays must still be grounded for the half-sloper but the arrangement is somewhat simpler.

### TEMPORARY ANTENNAS

Not everyone needs permanent antennas. A variety of temporary antennas can be arranged. A few of these are shown in **Figs 66, 67** and **68**. Of all of these the rigid dipole



**Fig 62—Feeding the backstay without an insulator at the top. The feed point may be moved along the antenna to find a point with a better match on a particular band or to provide a better range of impedances for the tuner to match. The coaxial feed line is taped to the lower portion of the backstay. Again, a good local ground is needed at the base of the backstay.**

(**Fig 66**) will provide the best operation and will have a pattern close to that expected from a freestanding dipole. The other two examples will be strongly affected by their close proximity to the rigging.

### GROUNDING SYSTEMS

You may be sitting in the middle of a thousand miles of saltwater. This is great for propagation but you will still have to connect to that ground if you want to use a vertical. There are many possibilities, but the scheme shown in **Fig 69** is representative. First a bonding wire, or better yet a copper strap (it can be very thin!), is connected from bow-to-stern on each side, connecting the forestay, lifeline stanchions, chainplates, bow and stern pulpits and the backstay. Other bonding wires are run from the bow, stern and chainplates

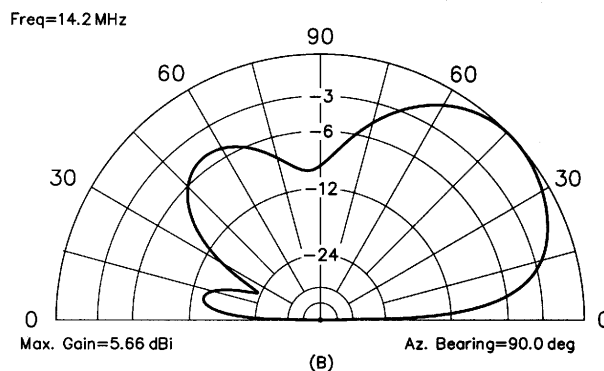
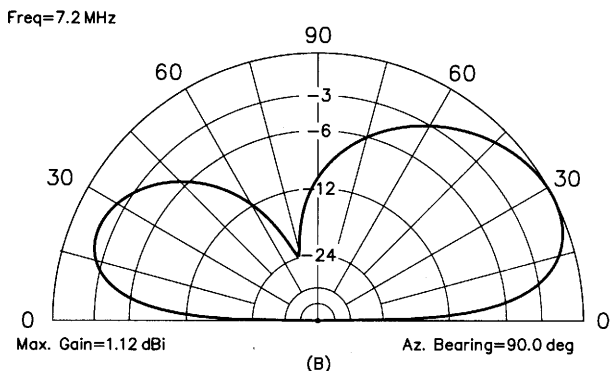
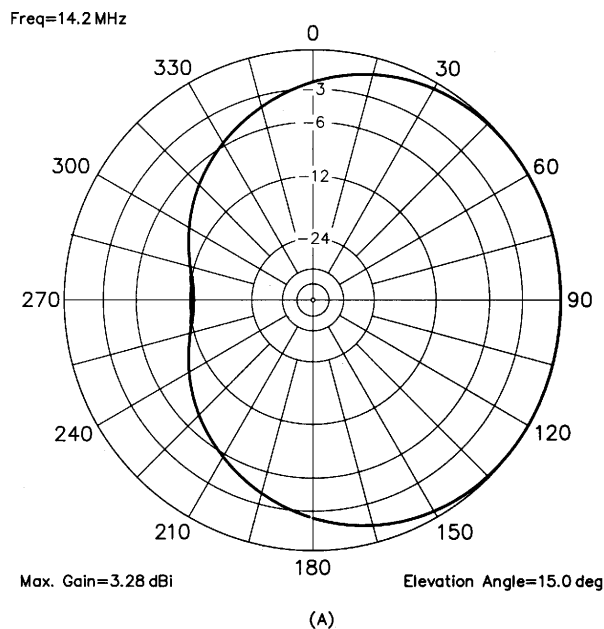
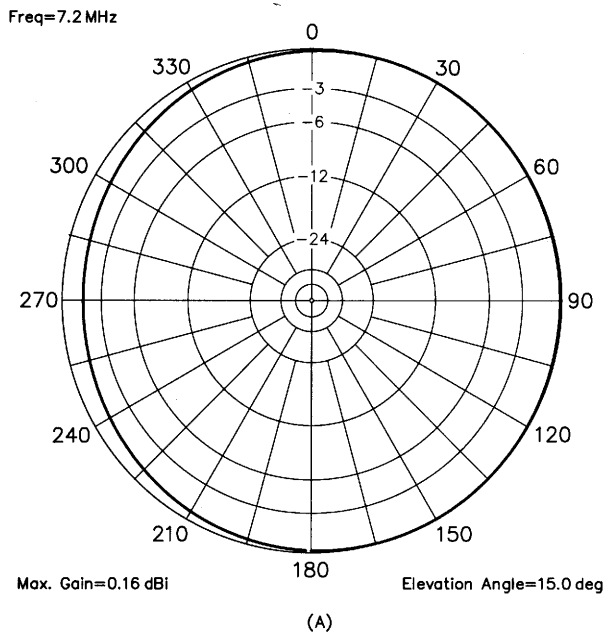


Fig 63—Typical 40-meter radiation pattern in Fig 62.

Fig 64—Typical 20-meter radiation pattern in Fig 62.

on both sides to a common connection at the base of the mast. The fore-and-aft bonding can be attached to the engine and to the keel bolts. The question arises: “What about electrolysis between the keel and propeller if you bond them together?” This has to be dealt with on a case-by-case basis. If your protective zincs are depleting more rapidly after you

install a bonding scheme, change it by disconnecting something, the engine-shaft-propeller, for example.

Grounding will vary in every installation and has to be customized to each vessel. However, just as on shore, the better the ground system, the better the performance of the vertical!

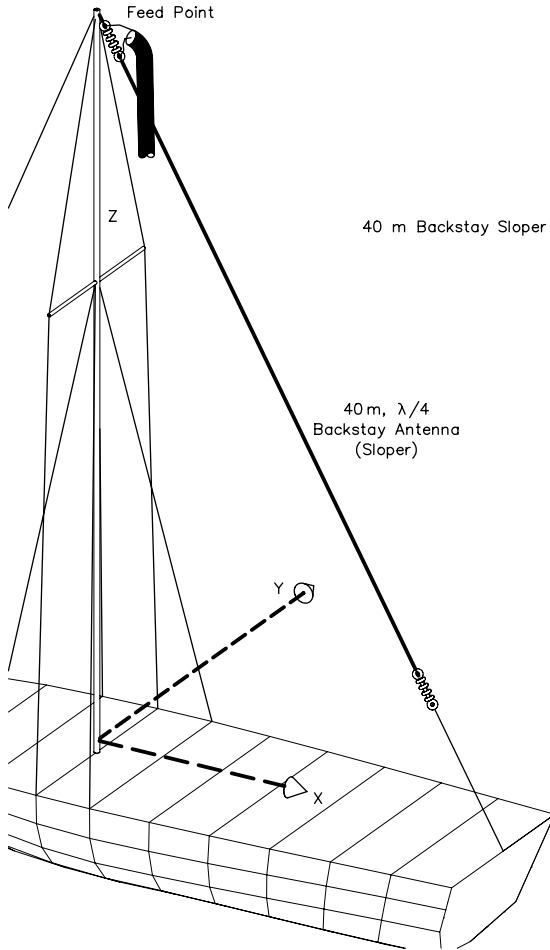


Fig 65—A 40-meter half-sloper fed at the masthead.

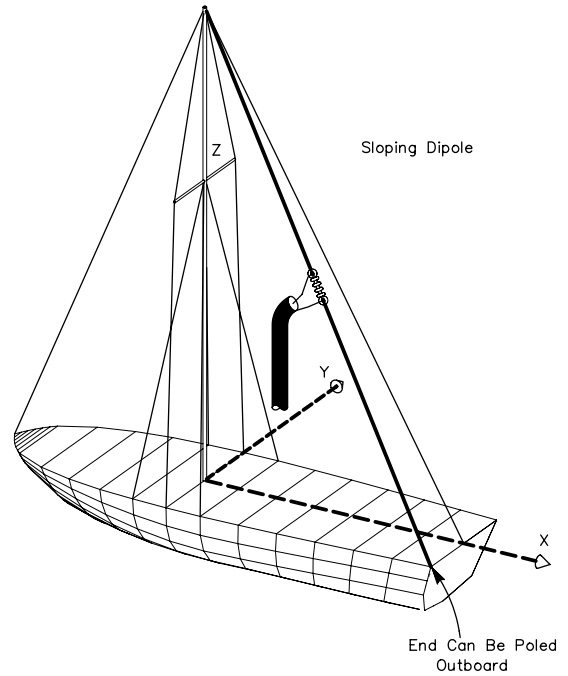


Fig 67—One end of dipole can be attached to the main halyard and pulled up to the masthead. The bottom end of the dipole should be poled out away from the rigging as much as possible to reduce the impact of the rigging on the impedance.

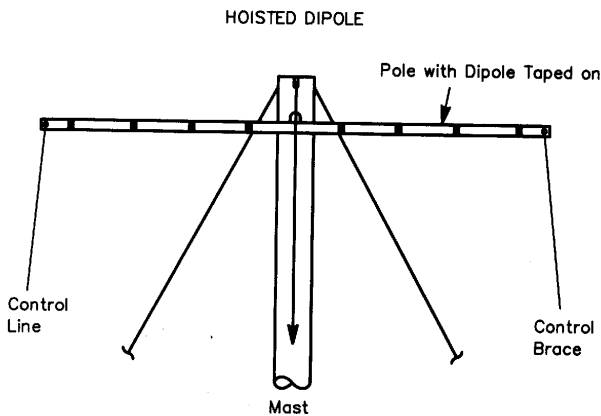


Fig 66—A dipole can be taped to a wood or bamboo pole and hoisted to the masthead with the main halyard while at anchor. It is possible to make this a multiband dipole.

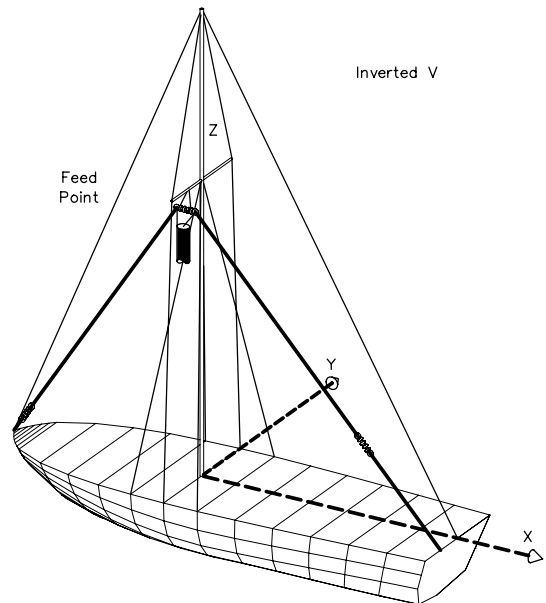
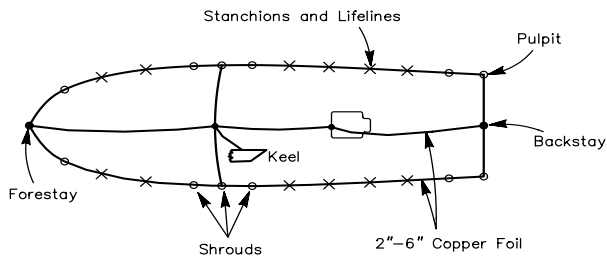


Fig 68—The flag halyard can be used to hoist the center of an inverted V to the spreaders, or alternatively, the main halyard can be used to hoist the center of the antenna to the masthead. Interaction between the rigging and the antenna will be very pronounced and the length of the antenna will have to be adjusted on a cut-and-try basis.





**Fig 69—A typical sailboat grounding scheme.**

## ANTENNAS FOR POWER BOATS

Powerboaters are not usually faced with the problems and opportunities created by the mast and rigging on a sailboat. A powerboat may have a small mast, but usually not on the same scale as a sailboat. Antennas for power boats have much more in common with automotive mobile operation, but with some important exceptions:

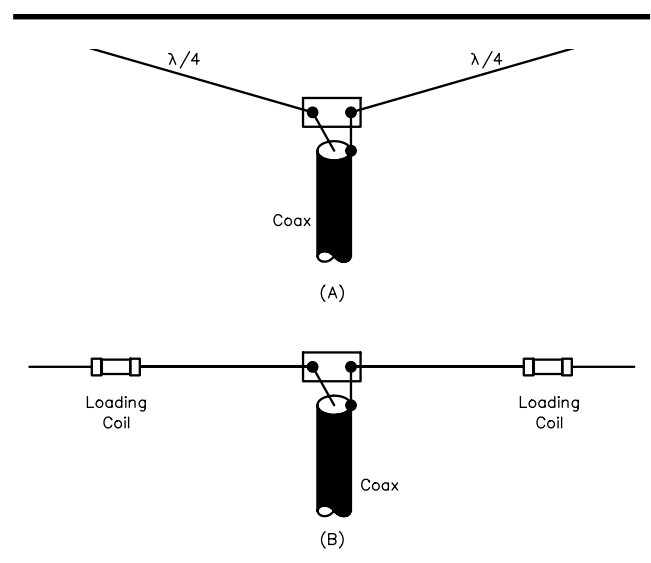
- 1) In an automobile, the body is usually metal and it provides a groundplane or counterpoise for a whip antenna. Most modern powerboats, however, have fiberglass hulls. These are basically insulators, and will not work as counterpoises. (On the other hand, metal-hulled power boats can provide nearly ideal grounding!)
- 2) A height restriction on automotive mobile whips is imposed by clearance limits on highway overpasses and also by the need to sustain wind speeds of up to 80 miles per hour on the highway.
- 3) In general, powerboats can have much taller antennas that can be lowered for the occasional low bridge.
- 4) The motion on a powerboat, especially in rough seas, can be quite severe. This places additional mechanical strain on the antennas.
- 5) On both powerboats and sailboats, operation in a salt-water marine environment is common. This means that a careful choice of materials must be made for the antennas to prevent corrosion and premature failure.

The problem of a ground plane for vertical antennas can be handled in much the same manner as shown in **Fig 69** for sailboats. Since there will most likely not be a large keel structure to connect to and provide a large surface area, additional copper foil can be added inside the hull to increase the counterpoise area. Because of the small area of the propeller, it may be better not to connect to the engine, but to rely instead on increasing the area of the counterpoise and operate it as a true counterpoise—that is, isolated from ground. Sometimes a number of radial wires are used for a vertical, much like that for a ground-plane antenna. This is not a very good idea unless the “wires” are actually wide copper-foil strips that can lower the Q substantially.

The problem is the high voltage present at the ends of normal ground-plane antenna radials. For a boat these radials are likely to be in close proximity to the cabin, which in turn

contains both people and electronic equipment. The high potential at the ends of the radials is both a safety hazard and can result in RF coupling back into the equipment, including ham gear, navigational instruments and entertainment devices. The cook is not likely to be happy if he or she gets an RF burn after touching the galley stove! Decoupling the counterpoise from the transmission line, as discussed in **Chapter 6**, can be very helpful to keep RF out of other equipment.

One way to avoid many of the problems associated with grounding is to use a rigid dipole antenna. On 20 meters and higher, a rigid dipole made up from aluminum tubing, fiberglass poles or some combination of these, can be effective. As shown in **Fig 70A** the halves of the dipole can be slanted upward like rabbit ears to reduce the wingspan and increase the feed-point impedance for a better match to common coax lines. On the lower bands a pair of mobile whips can be used, as shown in **Fig 70B**. Home-brew coils could also be used.



**Fig 70—At A, a rigid dipole made from aluminum tubing, fiberglass poles or a combination of these. At B, a pair of mobile whips used as a dipole.**

For short-range communication, a relatively low dipole over saltwater can be effective. However, if long-range communication is needed, then a well-designed vertical, operating over seawater, will work much better. For these to work, of course, you must solve the ground problems associated with a vertical.

It is not uncommon for large powerboats to have a two or three-element multiband Yagi installed on a short mast. While these can be effective, if they are not mounted high ( $> \lambda/2$ ) they may be disappointing for longer-range communication. Over saltwater, vertical polarization is very effective for longer distances. A simpler, but well-designed, vertical system on a boat may outperform a low Yagi.

The combination of a good ground system and one of the high-quality, motor-tuned multiband mobile whips now available commercially can also be very effective.

### BIBLIOGRAPHY

Source material and more extended discussions of topics covered in this chapter can be found in the references given

below and in the textbooks listed at the end of [Chapter 2](#).

- J. S. Belrose, "Short Antennas for Mobile Operation," *QST*, Sep 1953.
- J. S. Belrose, "Vertical J Antenna for 2 meters," *The Canadian Amateur*, Jul/Aug 1979, pp 23-26.
- J. M. Boyer, "Antenna-Transmission Line Analog," *Ham Radio*, May 1977.
- B. F. Brown, "Tennamatic: An Auto-Tuning Mobile Antenna System," *73*, Jul 1979.
- B. F. Brown, "Optimum Design of Short Coil-Loaded High-Frequency Mobile Antennas," *ARRL Antenna Compendium Volume 1* (Newington: ARRL, 1985), p 108.
- W. B. Freely, "A Two-meter J Antenna," *QST*, Apr 1977, pp 35-36.
- E. A. Laport, *Radio Antenna Engineering* (New York: McGraw-Hill Book Co., 1952), p 23.
- C. E. Smith and E. M. Johnson, "Performance of Short Antennas," Proceedings of the IRE, Oct 1947.
- F. E. Terman, *Radio Engineering Handbook*, 3<sup>rd</sup> edition (New York: McGraw-Hill Book Co., 1947), p 74.

# Repeater Antenna Systems

There is an old adage in Amateur Radio that goes “If your antenna did not fall down last winter, it wasn’t big enough.” This adage might apply to antennas for MF and HF work, but at VHF things are a bit different, at least as far as antenna size is concerned. VHF antennas are smaller than their HF counterparts, yet the theory is the same; a dipole is a dipole, and a Yagi is a Yagi, regardless of frequency. A 144-MHz Yagi may pass as a TV antenna, but most neighbors can easily detect a radio hobbyist if a 14-MHz Yagi looms over his property.

Repeater antennas are discussed in this chapter. Because the fundamental operation of these antennas is no different from what is presented in [Chapter 2](#), there is no need to delve into any exotic theory. Certain considerations must be made and certain precautions must be observed, however, as most repeater operations—amateur and commercial—take place at VHF and UHF.

## Basic Concepts

The antenna is a vital part of any repeater installation. Because the function of a repeater is to extend the range of communications between mobile and portable stations, the repeater antenna should be installed in the best possible location to provide the desired coverage. This usually means getting the antenna as high above average terrain as possible. In some instances, a repeater may need to have coverage only in a limited area or direction. When this is the case, antenna installation requirements will be completely different, with certain limits being set on height, gain and power.

### *Horizontal and Vertical Polarization*

Until the upsurge in FM repeater activity several years ago, most antennas used in amateur VHF work were horizontally polarized. These days, very few repeater groups use horizontal polarization. (One of the major reasons for using horizontal polarization is to allow separate repeaters to share the same input and/or output frequencies with closer than normal geographical spacing.) The vast majority of VHF and UHF repeaters use vertically polarized antennas, and all the antennas discussed in this chapter are of that type.

## *Transmission Lines*

Repeaters provide the first venture into VHF and UHF work for many amateurs. The uninitiated may not be aware that the transmission lines used at VHF become very important because feed-line losses increase with frequency.

The characteristics of feed lines commonly used at VHF are discussed in [Chapter 24](#). Although information is provided for RG-58 and RG-59, these should not be used except for very short feed lines (25 feet or less). These cables are very lossy at VHF. In addition, the losses can be much higher if the fittings and connections are not carefully installed.

The differences in loss between solid polyethylene dielectric types (RG-8 and RG-11) and those using foam polyethylene (FM8 and FM11) are significant. If you can afford the line with the least loss, buy it.

If coaxial cable must be buried, check with the cable manufacturer before doing so. Many popular varieties of coaxial cable should not be buried, as the dielectric can become contaminated from moisture and soil chemicals. Some coaxial cables are labeled as non-contaminating. Such a label is the best way to be sure your cable can be buried without damage.

## Matching

Losses are lowest in transmission lines that are matched to their characteristic impedances. If there is a mismatch at the end of the line, the losses increase.

The *only way* to reduce the SWR on a transmission line is by matching the line *at* the antenna. Changing the length of a transmission line does not reduce the SWR. The SWR is established by the impedance of the line and the impedance of the antenna, so matching must be done at the antenna end of the line.

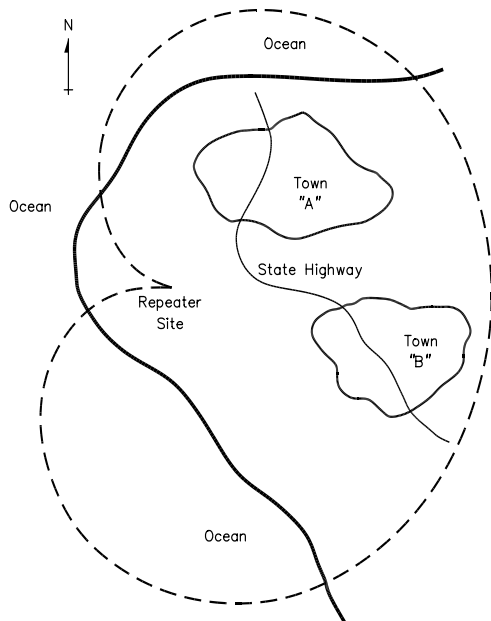
The importance of matching, as far as feed-line losses are concerned, is sometimes overstressed. But under some conditions, it is necessary to minimize feed-line losses related to SWR if repeater performance is to be consistent. It is important to keep in mind that most VHF/UHF equipment is designed to operate into a 50- $\Omega$  load. The output circuitry will not be loaded properly if connected to a mismatched line. This leads to a loss of power, and in some cases, damage to the transmitter.

# Repeater Antenna System Design

Choosing a repeater or remote-base antenna system is as close as most amateurs come to designing a commercial-grade antenna system. The term *system* is used because most repeaters utilize not only an antenna and a transmission line, but also include duplexers, cavity filters, circulators or isolators in some configuration. Assembling the proper combination of these items in constructing a reliable system is both an art and a science. In this section prepared by Domenic Mallozzi, N1DM, the functions of each component in a repeater antenna system and their successful integration are discussed. While every possible complication in constructing a repeater is not foreseeable at the outset, this discussion should serve to steer you along the right lines in solving any problems encountered.

## The Repeater Antenna

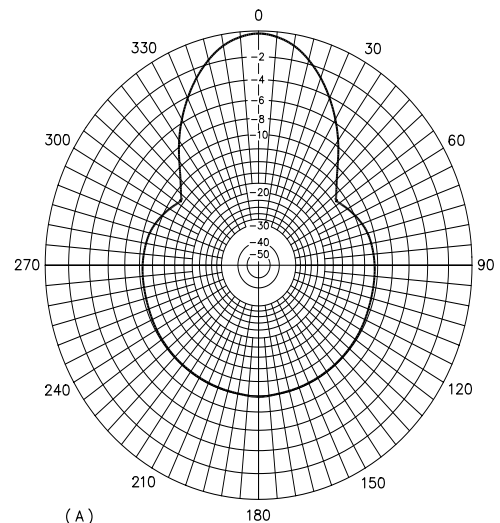
The most important part of the system is the antenna itself. As with any antenna, it must radiate and collect RF energy as efficiently as possible. Many repeaters use omnidirectional antennas, but this is not always the best choice. For example, suppose a group wishes to set up a repeater to cover towns A and B and the interconnecting state highway shown in **Fig 1**. The X shows the available repeater site on the map. No coverage is required to the west



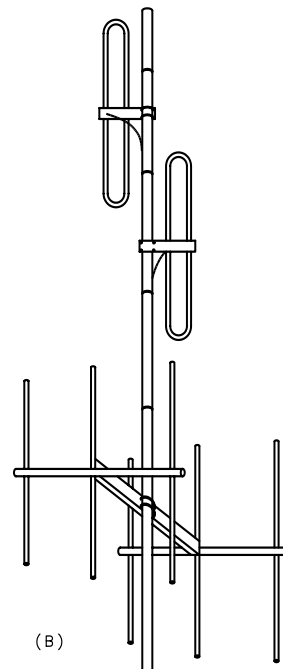
**Fig 1**—There are many situations where equal repeater coverage is not desired in all directions from the “machine.” One such situation is shown here, where the repeater is needed to cover only towns A and B and the interconnecting highway. An omnidirectional antenna would provide coverage in undesired directions, such as over the ocean. The broken line shows the radiation pattern of an antenna that is better suited to this circumstance.

or south, or over the ocean. If an omnidirectional antenna is used in this case, a significant amount of the radiated signal goes in undesired directions. By using an antenna with a cardioid pattern, as shown in Fig 1, the coverage is concentrated in the desired directions. The repeater will be more effective in these locations, and signals from low-power portables and mobiles will be more reliable.

In many cases, antennas with special patterns are more



(A)



(B)

**Fig 2**—The “keyhole” horizontal radiation pattern at A is generated by the combination of phased Yagis and vertical elements shown at B. Such a pattern is useful in overcoming coverage blockages resulting from local terrain features. (Based on a design by Decibel Products, Inc)

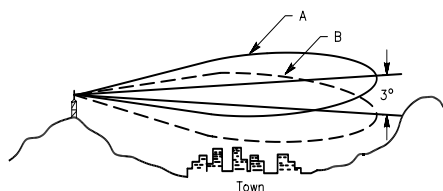
expensive than omnidirectional models. This is an obvious consideration in designing a repeater antenna system.

Over terrain where coverage may be difficult in some direction from the repeater site, it may be desirable to skew the antenna pattern in that direction. This can be accomplished by using a phased-vertical array or a combination of a Yagi and a phased vertical to produce a “keyhole” pattern. See [Fig 2](#).

As repeaters are established on 440 MHz and above, many groups are investing in high-gain omnidirectional antennas. A consequence of getting high gain from an omnidirectional antenna is vertical beamwidth reduction. In most cases, these antennas are designed to radiate their peak gain at the horizon, resulting in optimum coverage when the antenna is located at a moderate height over normal terrain. Unfortunately, in cases where the antenna is located at a very high site (overlooking the coverage area) this is not the most desirable pattern. In a case like this, the vertical pattern of the antenna can be tilted downward to facilitate coverage of the desired area. This is called *vertical-beam downtilt*.

An example of such a situation is shown in [Fig 3](#). The repeater site overlooks a town in a valley. A 450-MHz repeater is needed to serve low power portable and mobile stations. Constraints on the repeater dictate the use of an antenna with a gain of 11 dBi. (An omnidirectional antenna with this gain has a vertical beamwidth of approximately  $6^\circ$ .) If the repeater antenna has its peak gain at the horizon, a major portion of the transmitted signal and the best area from which to access the repeater exists *above* the town. By tilting the pattern down  $3^\circ$ , the peak radiation will occur in the town.

Vertical-beam downtilt is generally produced by feeding the elements of a collinear vertical array slightly out of phase with each other. [Lee Barrett, K7NM](#), showed such an array in *Ham Radio*. (See the Bibliography at the end of this chapter.) Barrett gives the geometry and design of a four-pole array with progressive phase delay, and a computer program to model it. The technique is shown in [Fig 4](#).



**Fig 3—Vertical-beam downtilt is another form of radiation-pattern distortion useful for improving repeater coverage. This technique can be employed in situations where the repeater station is at a greater elevation than the desired coverage area, when a high-gain omnidirectional antenna is used. Pattern A shows the normal vertical-plane radiation pattern of a high-gain omnidirectional antenna with respect to the desired coverage area (the town). Pattern B shows the pattern tilted down, and the coverage improvement is evident.**

Commercial antennas are sometimes available (at extra cost) with built-in downtilt characteristics. Before ordering such a commercial antenna, make sure that you really require it; they generally are special order items and are not returnable.

There are disadvantages to improving coverage by means of vertical-beam downtilt. When compared to a standard collinear array, an antenna using vertical-beam downtilt will have somewhat greater extraneous lobes in the vertical pattern, resulting in reduced gain (usually less than 1 dB). Bandwidth is also slightly reduced. The reduction in gain, when combined with the downtilt characteristic, results in a reduction in total coverage area. These trade-offs, as well as the increased cost of a commercial antenna with downtilt, must be compared to the improvement in total performance in a situation where vertical-beam downtilt is required.

### Top Mounting and Side Mounting

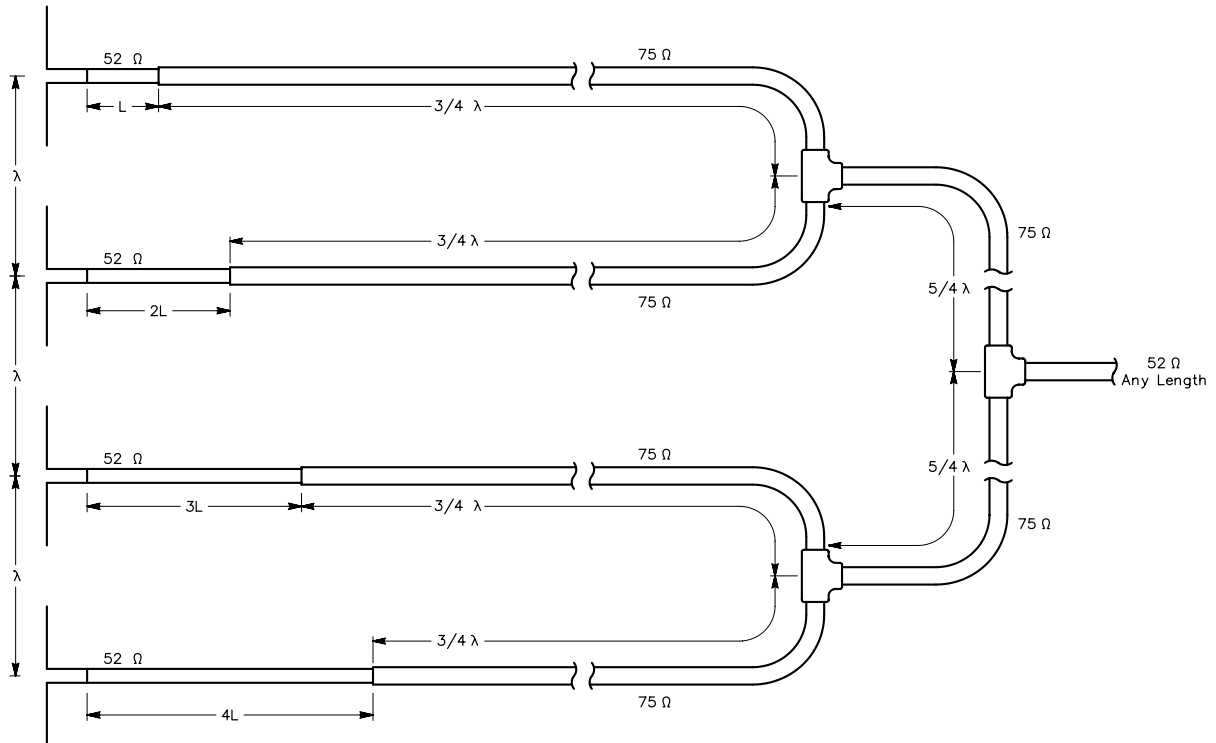
Amateur repeaters often share towers with commercial and public service users. In many of these cases, other antennas are at the top of the tower, so the amateur antenna must be side mounted. A consequence of this arrangement is that the free-space pattern of the repeater antenna is distorted by the tower. This effect is especially noticeable when an omnidirectional antenna is side mounted on a structure.

The effects of supporting structures are most pronounced at close antenna spacings to the tower and with large support dimensions. The result is a measurable increase in gain in one direction and a partial null in the other direction (sometimes 15 dB deep). The shape of the supporting structure also influences pattern distortion. Many antenna manufacturers publish radiation patterns showing the effect of side mounting antennas in their catalogs.

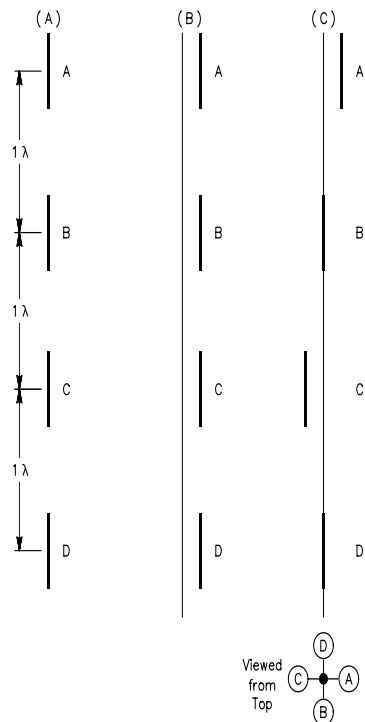
Side mounting is not always a disadvantage. In cases where more (or less) coverage is desired in one direction, the supporting structure can be used to advantage. If pattern distortion is not acceptable, a solution is to mount antennas around the perimeter of the structure and feed them with the proper phasing to synthesize an omnidirectional pattern. Many manufacturers make antennas to accommodate such situations.

The effects of different mounting locations and arrangements can be illustrated with an array of exposed dipoles, [Fig 5](#). Such an array is a very versatile antenna because, with simple rearrangement of the elements, it can develop either an omnidirectional pattern or an offset pattern. Drawing A of [Fig 5](#) shows a basic collinear array of four vertical  $\frac{1}{2}\lambda$  elements. The vertical spacing between adjacent elements is  $1\lambda$ . All elements are fed in phase. If this array is placed in the clear and supported by a nonconducting mast, the calculated radiation resistance of each dipole element is on the order of  $63\ \Omega$ . If the feed line is completely decoupled, the resulting azimuth pattern is omnidirectional. The vertical-plane pattern is shown in [Fig 6](#).

[Fig 5B](#) shows the same array in a side mounting



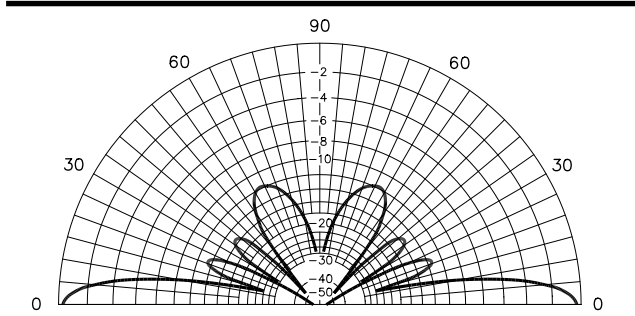
**Fig 4**—Vertical-beam downtilt can be facilitated by inserting 52-Ω delay lines in series with the 75-Ω feed lines to the collinear elements of an omnidirectional antenna. The delay lines to each element are progressively longer so the phase shift between elements is uniform. Odd  $\frac{1}{4}\lambda$  coaxial transformers are used in the main (75-Ω) feed system to match the dipole impedances to the driving point. Tilting the vertical beam in this way often produces minor lobes in the vertical pattern that do not exist when the elements are fed in phase.



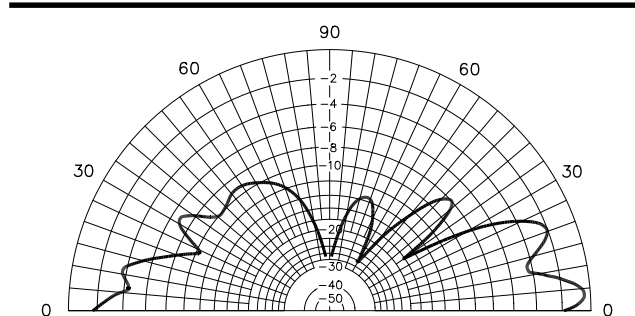
arrangement, at a spacing of  $\frac{1}{4}\lambda$  from a conducting mast. In this mounting arrangement, the mast takes on the role of a reflector, producing an F/B ratio on the order of 5.7 dB. The azimuth pattern is shown in Fig 7. The vertical pattern is not significantly different from that of Fig 6, except the four small minor lobes (two on either side of the vertical axis) tend to become distorted. They are not as “clean,” tending to merge into one minor lobe at some mast heights. This apparently is a function of currents in the supporting mast. The proximity of the mast also alters the feed-point impedance. For elements that are resonant in the configuration of Fig 5A, the calculated impedance in the arrangement of Fig 5B is in the order of  $72 + j10 \Omega$ .

If side mounting is the only possibility and an omnidirectional pattern is required, the arrangement of Fig 5C may be used. The calculated azimuth pattern takes on a slight

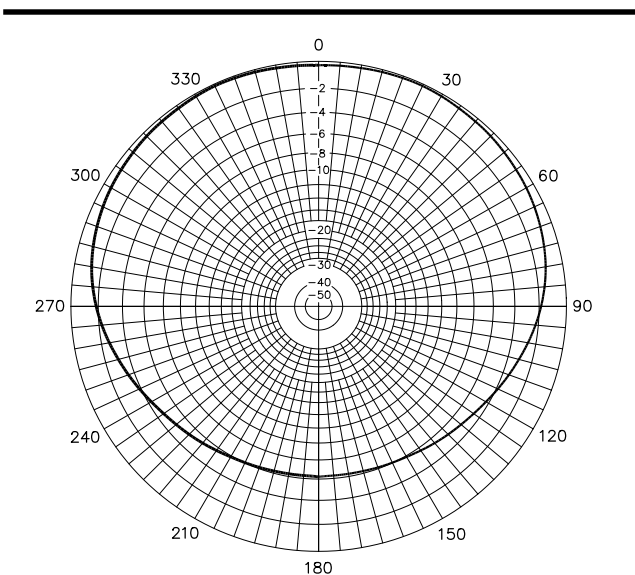
**Fig 5**—Various arrangements of exposed dipole elements. At A is the basic collinear array of four elements. B shows the same elements mounted on the side of a mast, and C shows the elements in a side-mounted arrangement around the mast for omnidirectional coverage. See text and Figs 6, 7 and 8 for radiation pattern information.



**Fig 6**—Calculated vertical-plane pattern of the array of Fig 5A, assuming a nonconducting mast support and complete decoupling of the feeder. In azimuth the array is omnidirectional. The calculated gain of the array is 8.6 dBi at 0° elevation; the -3 dB point is at 6.5°.



**Fig 8**—Calculated vertical pattern of the array of Fig 5C, assuming  $\frac{1}{4}\lambda$  element spacing from a 4-inch mast. The azimuth pattern is circular within 1.5 dB, and the calculated gain is 4.4 dBi.



**Fig 7**—Calculated azimuth pattern of the side-mounted array of Fig 5B, assuming  $\frac{1}{4}\lambda$  spacing from a 4-inch mast. The calculated gain in the favored direction, away from the mast and through the elements, is 10.6 dBi.

cloverleaf shape, but is within 1.5 dB of being circular. However, gain performance suffers, and the idealized vertical pattern of Fig 6 is not achieved. See Fig 8. Spacings other than  $\frac{1}{4}\lambda$  from the mast were not investigated.

One very important consideration in side mounting an antenna is mechanical integrity. As with all repeater components, reliability is of great importance. An antenna hanging by the feed line and banging against the tower provides far from optimum performance and reliability. Use a mount that is appropriately secured to the tower and the antenna. Also use good hardware, preferably stainless steel (or bronze). If your local hardware store does not carry stainless steel hardware, try a boating supplier.

Be certain that the feed line is properly supported along its length. Long lengths of cable are subject to contraction

and expansion with temperature from season to season, so it is important that the cable not be so tight that contraction causes it to stress the connection at the antenna. This can cause the connection to become intermittent (and noisy) or, at worst, an open circuit. This is far from a pleasant situation if the antenna connection is 300 feet up a tower, and it happens to be the middle of the winter!

### Effects of Other Conductors

Feed-line proximity and tower-access ladders or cages also have an effect on the radiation patterns of side-mounted antennas. This subject was studied by Connolly and Blevins, and their findings are given in *IEEE Conference Proceedings* (see the Bibliography at the end of this chapter). Those considering mounting antennas on air conditioning evaporators or maintenance penthouses on commercial buildings should consult this article. It gives considerable information on the effects of these structures on both unidirectional and omnidirectional antennas.

Metallic guy wires also affect antenna radiation patterns. Yang and Willis studied this and reported the results in *IRE Transactions on Vehicular Communications*. As expected, the closer the antenna is to the guy wires, the greater the effect on the radiation patterns. If the antennas are near the point where the guy wires meet the tower, the effect of the guy wires can be minimized by breaking them up with insulators every  $0.75\lambda$  for  $2.25\lambda$  to  $3.0\lambda$ .

### ISOLATION REQUIREMENTS IN REPEATER ANTENNA SYSTEMS

Because repeaters generally operate in full duplex (the transmitter and receiver operate simultaneously), the antenna system must act as a filter to keep the transmitter from blocking the receiver. The degree to which the transmitter and receiver must be isolated is a complex problem. It is quite dependent on the equipment used and the difference in transmitter and receiver frequencies (offset). Instead of going into great detail, a simplified example can be used for illustration.

Consider the design of a 144-MHz repeater with a

600-kHz offset. The transmitter has an RF output power of 10 W, and the receiver has a squelch sensitivity of 0.1  $\mu\text{V}$ . This means there must be at least  $1.9 \times 10^{-16}$  W at the 52- $\Omega$  receiver-antenna terminals to detect a signal. If both the transmitter and receiver were on the same frequency, the isolation (attenuation) required between the transmitter and receiver antenna jacks to keep the transmitter from activating the receiver would be

$$\text{Isolation} = 10 \log \frac{10 \text{ watts}}{1.9 \times 10^{-16} \text{ watts}} = 167 \text{ dB}$$

Obviously there is no need for this much attenuation, because the repeater does not transmit and receive on the same frequency.

If the 10-W transmitter has noise 600 kHz away from the carrier frequency that is 45 dB below the carrier power, that 45 dB can be subtracted from the isolation requirement. Similarly, if the receiver can detect a 0.1  $\mu\text{V}$  on-frequency signal in the presence of a signal 600 kHz away that is 40 dB greater than 0.1  $\mu\text{V}$ , this 40 dB can also be subtracted from the isolation requirement. Therefore, the isolation requirement is

$$167 \text{ dB} - 45 \text{ dB} - 40 \text{ dB} = 82 \text{ dB}$$

Other factors enter into the isolation requirements as well. For example, if the transmitter power is increased by 10 dB (from 10 to 100 W), this 10 dB must be added to the isolation requirement. Typical requirements for 144 and 440-MHz repeaters are shown in **Fig 9**.

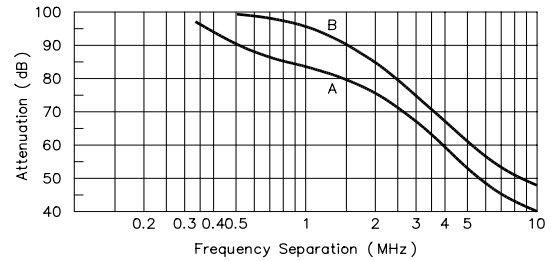
Obtaining the required isolation is the first problem to be considered in constructing a repeater antenna system. There are three common ways to obtain this isolation:

- 1) Physically separate the receiving and transmitting antennas so the combination of path loss for the spacing and the antenna radiation patterns results in the required isolation.
- 2) Use a combination of separate antennas and high-Q filters to develop the required isolation. (The high-Q filters serve to reduce the physical distance required between antennas.)
- 3) Use a combination filter and combiner system to allow the transmitter and receiver to share one antenna. Such a filter and combiner is called a *duplexer*.

Repeaters operating on 28 and 50 MHz generally use separate antennas to obtain the required isolation. This is largely because duplexers in this frequency range are both large and very expensive. It is generally less expensive to buy two antennas and link the sites by a committed phone line or an RF link than to purchase a duplexer. At 144 MHz and higher, duplexers are more commonly used. Duplexers are discussed in greater detail in a later section.

### Separate Antennas

Receiver desensing (gain limiting caused by the presence of a strong off-frequency signal) can be reduced, and often eliminated, by separation of the transmitting and receiving antennas. Obtaining the 55 to 90 dB of isolation required for a repeater antenna system requires separate



**Fig 9—Typical isolation requirements for repeater transmitters and receivers operating in the 132-174 MHz band (Curve A), and the 400-512 MHz band (Curve B). Required isolation in dB is plotted against frequency separation in MHz. These curves were developed for a 100-W transmitter. For other power levels, the isolation requirements will differ by the change in decibels relative to 100 W. Isolation requirements will vary with receiver sensitivity. (The values plotted were calculated for transmitter-carrier and receiver-noise suppression necessary to prevent more than 1 dB degradation in receiver 12-dB SINAD sensitivity.)**

antennas to be spaced a considerable distance apart (in wavelengths).

**Fig 10** shows the distances required to obtain specific values of isolation for vertical dipoles having horizontal separation (at A) and vertical separation (at B). The isolation gained by using separate antennas is subtracted from the total isolation requirement of the system. For example, if the transmitter and receiver antennas for a 450-MHz repeater are separated horizontally by 400 feet, the total isolation requirement in the system is reduced by about 64 dB.

Note from **Fig 10B** that a vertical separation of only about 25 feet also provides 64 dB of isolation. Vertical separation yields much more isolation than does horizontal separation. Vertical separation is also more practical than horizontal, as only a single support is required.

An explanation of the significant difference between the two graphs is in order. The vertical spacing requirement for 60 dB attenuation (isolation) at 150 MHz is about 43 feet. The horizontal spacing for the same isolation level is on the order of 700 feet. **Fig 11** shows why this difference exists. The radiation patterns of the antennas at A overlap; each antenna has gain in the direction of the other. The path loss between the antennas is given by

$$\text{Path loss (dB)} = 20 \log \frac{4\pi d}{\lambda}$$

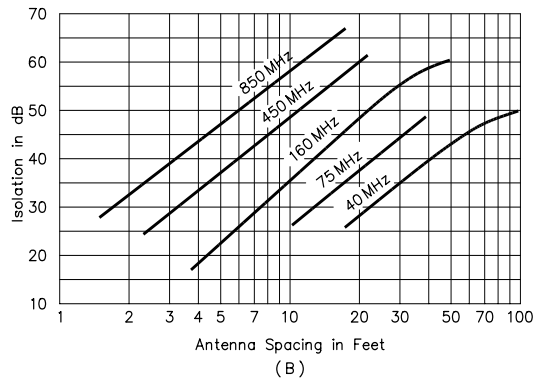
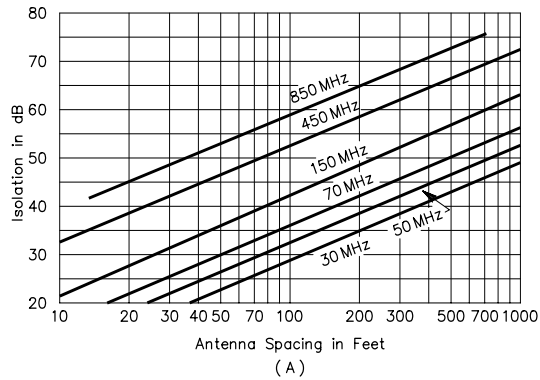
where

d = distance between antennas

$\lambda$  = wavelength, in the same units as d

The isolation between the antennas in **Fig 11A** is the path loss less the antenna gains. Conversely, the antennas at B share pattern nulls, so the isolation is the path loss added to the depth of these nulls. This significantly reduces the spacing requirement for vertical separation. Because the





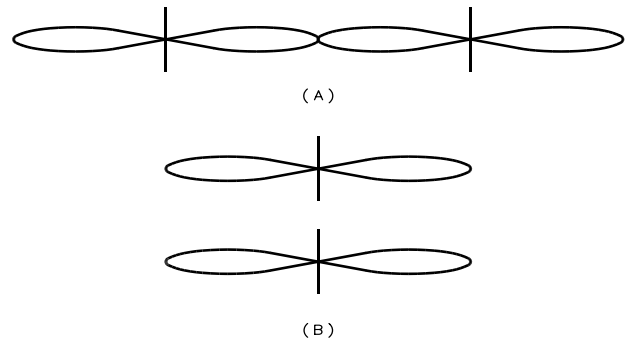
**Fig 10—At A, the amount of attenuation (isolation) provided by horizontal separation of vertical dipole antennas. At B, isolation afforded by vertical separation of vertical dipoles.**

depth of the pattern nulls is not infinite, some spacing is required. Combined horizontal and vertical spacing is much more difficult to quantify because the results are dependent on both radiation patterns and the positions of the antennas relative to each other.

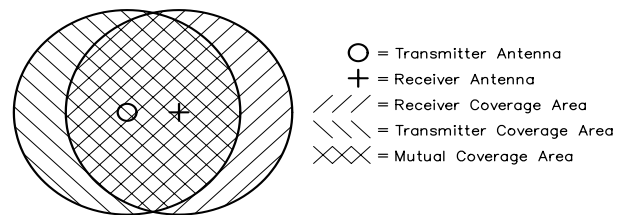
Separate antennas have one major disadvantage: They create disparity in transmitter and receiver coverage. For example, say a 50-MHz repeater is installed over average terrain with the transmitter and repeater separated by 2 miles. If both antennas had perfect omnidirectional coverage, the situation depicted in **Fig 12** would exist. In this case, stations able to hear the repeater may not be able to access it, and vice versa. In practice, the situation can be considerably worse. This is especially true if the patterns of both antennas are not omnidirectional. If this disparity in coverage cannot be tolerated, the solution involves skewing the patterns of the antennas until their coverage areas are essentially the same.

### Cavity Resonators

As just discussed, receiver desensing can be reduced by separating the transmitter and receiver antennas. But the amount of transmitted energy that reaches the receiver input must often be decreased even farther. Other nearby transmitters can cause desensing as well. A *cavity resonator*



**Fig 11—A relative representation of the isolation advantage afforded by separating antennas horizontally (A) and vertically (B) is shown. A great deal of isolation is provided by vertical separation, but horizontal separation requires two supports and much greater distance to be as effective. Separate-site repeaters (those with transmitter and receiver at different locations) benefit much more from horizontal separation than do single-site installations.**

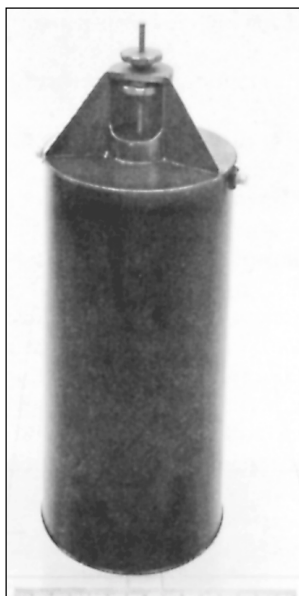


**Fig 12—Coverage disparity is a major problem for separate-site repeater antennas. The transmitter and receiver coverage areas overlap, but are not entirely mutually inclusive. Solving this problem requires a great deal of experimentation, as many factors are involved. Among these factors are terrain features and distortion of the antenna radiation patterns from supports.**

(cavity filter) can be helpful in solving these problems. When properly designed and constructed, this type of resonator has very high Q. A commercially made cavity is shown in **Fig 13**.

A cavity resonator placed in series with a transmission line acts as a band-pass filter. For a resonator to operate in series, it must have input and output coupling loops (or probes).

A cavity resonator can also be connected across (in parallel with) a transmission line. The cavity then acts as a band-reject (notch) filter, greatly attenuating energy at the frequency to which it is tuned. Only one coupling loop or probe is required for this method of filtering. This type of cavity could be used in the receiver line to “notch” the transmitter signal. Several cavities can be connected in series or parallel to increase the attenuation in a given



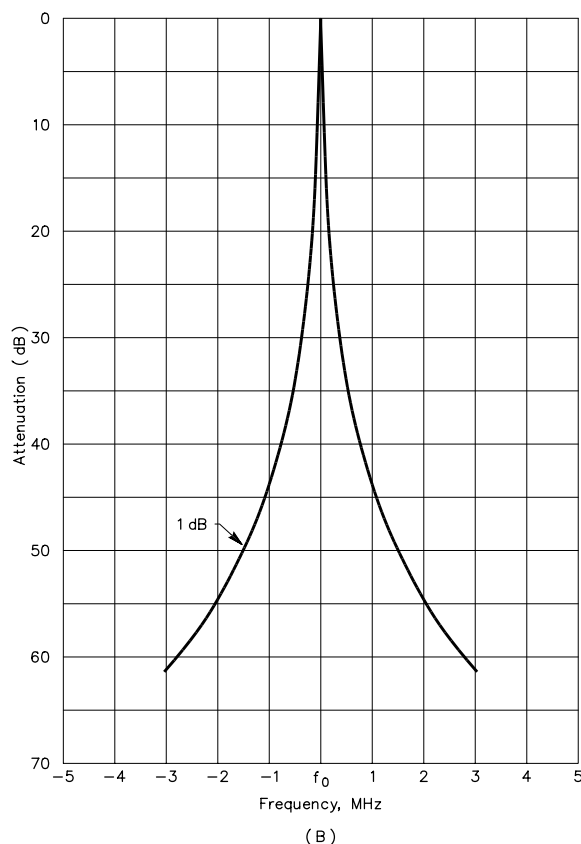
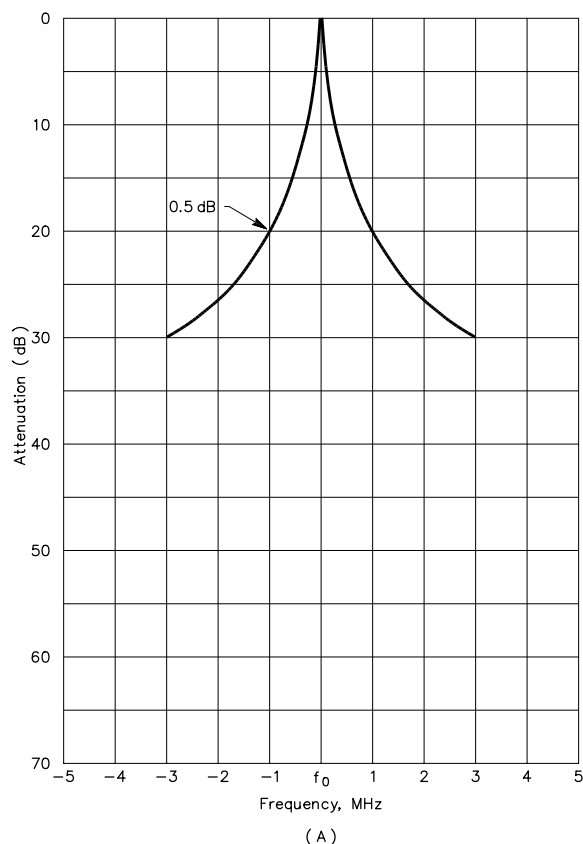
**Fig 13—A coaxial cavity filter of the type used in many amateur and commercial repeater installations. Center-conductor length (and thus resonant frequency) is varied by adjustment of the knob (top).**

configuration. The graphs of **Fig 14** show the attenuation of a single cavity (A) and a pair of cavities (B).

The only situation in which cavity filters would not help is the case where the off-frequency noise of the transmitter was right on the receiver frequency. With cavity resonators, an important point to remember is that addition of a cavity across a transmission line may change the impedance of the system. This change can be compensated by adding tuning stubs along the transmission line.

### Duplexers

The material in this section was prepared by Domenic Mallozzi, N1DM. Most amateur repeaters in the 144, 220 and 440-MHz bands use duplexers to obtain the necessary transmitter to receiver isolation. Duplexers have been commonly used in commercial repeaters for many years. The duplexer consists of two high-Q filters. One filter is used in the feed line from the transmitter to the antenna, and another between the antenna and the receiver. These filters



**Fig 14—Frequency response curves for a single cavity (A) and two cavities cascaded (B). These curves are for cavities with coupling loops, each having an insertion loss of 0.5 dB. (The total insertion loss is indicated in the body of each graph.) Selectivity will be greater if lighter coupling (greater insertion loss) can be tolerated.**

must have low loss at the frequency to which they are tuned while having very high attenuation at the surrounding frequencies. To meet the high attenuation requirements at frequencies within as little as 0.4% of the frequency to which they are tuned, the filters usually take the form of cascaded transmission-line cavity filters. These are either band-pass filters, or band-pass filters with a rejection notch. (The rejection notch is tuned to the center frequency of the other filter.) The number of cascaded filter sections is determined by the frequency separation and the ultimate attenuation requirements.

Duplexers for the amateur bands represent a significant technical challenge, because in most cases amateur repeaters operate with significantly less frequency separation than their commercial counterparts. Information on home construction of duplexers is presented in a later section of this chapter. Many manufacturers market high quality duplexers for the amateur frequencies.

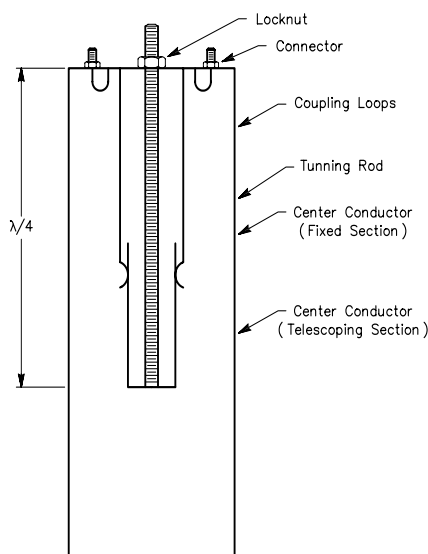
Duplexers consist of very high Q cavities whose resonant frequencies are determined by mechanical components, in particular the tuning rod. **Fig 15** shows the cutaway view of a typical duplexer cavity. The rod is usually made of a material which has a limited thermal expansion coefficient (such as Invar). Detuning of the cavity by environmental changes introduces unwanted losses in the antenna system. An article by [Arnold](#) in *Mobile Radio Technology* considered the causes of drift in the cavity (see the Bibliography at the end of this chapter). These can be broken into four major categories.

- 1) Ambient temperature variation (which leads to mechanical variations related to the thermal expansion coefficients of the materials used in the cavity).
- 2) Humidity (dielectric constant) variation.
- 3) Localized heating from the power dissipated in the cavity (resulting from its insertion loss).
- 4) Mechanical variations resulting from other factors (vibration, etc).

In addition, because of the high Q nature of these cavities, the insertion loss of the duplexer increases when the signal is not at the peak of the filter response. This means, in practical terms, less power is radiated for a given transmitter output power. Also, the drift in cavities in the receiver line results in increased system noise figure, reducing the sensitivity of the repeater.

As the frequency separation between the receiver and the transmitter decreases, the insertion loss of the duplexer reaches certain practical limits. At 144 MHz, the minimum insertion loss for 600 kHz spacing is 1.5 dB per filter.

Testing and using duplexers requires some special considerations (especially as frequency increases). Because duplexers are very high Q devices, they are very sensitive to the termination impedances at their ports. A high SWR on any port is a serious problem, because the apparent insertion loss of the duplexer will increase, and the isolation may appear to decrease. Some have found that, when duplexers are used at the limits of their isolation capabilities,



**Fig 15—Cutaway view of a typical cavity. Note the relative locations of the coupling loops to each other and to the center conductor of the cavity. A locknut is used to prevent movement of the tuning rod after adjustment.**

a small change in antenna SWR is enough to cause receiver desensitization. This occurs most often under ice-loading conditions on antennas with open-wire phasing sections.

The choice of connectors in the duplexer system is important. BNC connectors are good for use below 300 MHz. Above 300 MHz, their use is discouraged because even though many types of BNC connectors work well up to 1 GHz, older style standard BNC connectors are inadequate at UHF and above. Type N connectors should be used above 300 MHz. It is false economy to use marginal quality connectors. Some commercial users have reported deteriorated isolation in commercial UHF repeaters when using such connectors. The location of a bad connector in a system is a complicated and frustrating process. Despite all these considerations, the duplexer is still the best method for obtaining isolation in the 144 to 925-MHz range.

## ADVANCED TECHNIQUES

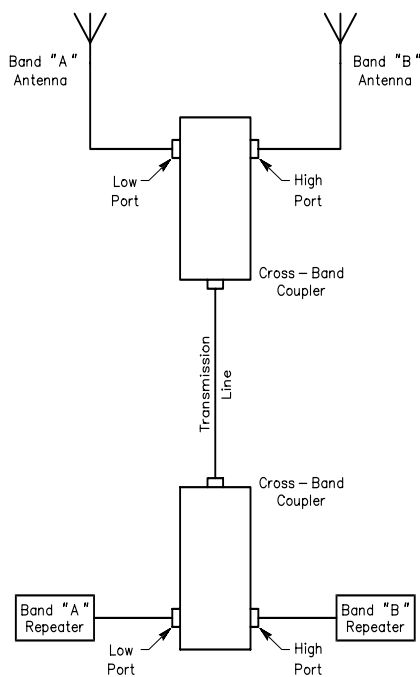
As the number of available antenna sites decreases and the cost of various peripheral items (such as coaxial cable) increases, amateur repeater groups are required to devise advanced techniques if repeaters are to remain effective. Some of the techniques discussed here have been applied in commercial services for many years, but until recently have not been economically justified for amateur use.

One technique worth consideration is the use of *cross-band* couplers. To illustrate a situation where a cross-band coupler would be useful, consider the following example. A repeater group plans to install 144 and 902-MHz repeaters on the same tower. The group intends to erect both antennas

on a horizontal cross-arm at the 325-foot level. A 325-foot run of 7/8-inch Heliac costs approximately \$1400. If both antennas are to be mounted at the top of the tower, the logical approach would require two separate feed lines. A better solution involves the use of a single feed line for both repeaters, along with a cross-band coupler at each end of the line.

The use of the cross-band coupler is shown in **Fig 16**. As the term implies, the coupler allows two signals on different bands to share a common transmission line. Such couplers cost approximately \$200 each. In our hypothetical example, this represents a saving of \$1000 over the cost of using separate feed lines. But, as with all compromises, there are disadvantages. Cross-band couplers have a loss of about 0.5 dB per unit. Therefore, the pair required represents a loss of 1.0 dB in *each transmission path*. If this loss can be tolerated, the cross-band coupler is a good solution.

Cross-band couplers do not allow two repeaters *on the same band* to share a single antenna and feed line. As repeater sites and tower space become more scarce, it may be desirable to have two repeaters on the same band share the same antenna. The solution to this problem is the use of a *transmitter multicoupler*. The multicoupler is related to the duplexers discussed earlier. It is a cavity filter and combiner which allows multiple transmitters and receivers to share the



**Fig 16**—Block diagram of a system using cross-band couplers to allow the use of a single feed line for two repeaters. If the feeder to the antenna location is long (more than 200 feet or so), cross-band couplers may provide a significant saving over separate feed lines, especially at the higher amateur repeater frequencies. Cross-band couplers cannot be used with two repeaters on the same band.

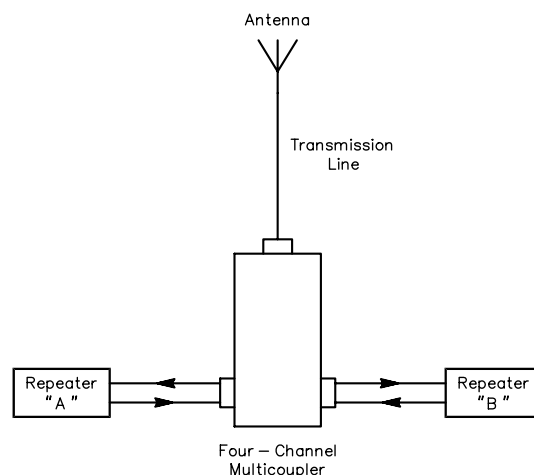
same antenna. This is a common commercial practice. A block diagram of a multicoupler system is shown in **Fig 17**.

The multicoupler, however, is a very expensive device, and has the disadvantage of even greater loss per transmission path than the standard duplexer. For example, a well-designed duplexer for 600 kHz spacing at 146 MHz has a loss per transmission path of approximately 1.5 dB. A four-channel multicoupler (the requirement for two repeaters) has an insertion loss per transmission path on the order of 2.5 dB or more. Another constraint of such a system is that the antenna must present a good match to the transmission line at all frequencies on which it will be used (both transmitting and receiving). This becomes difficult for the system with two repeaters operating at opposite ends of a band.

If you elect to purchase a commercial base station antenna that requires you to specify a frequency to which the antenna must be tuned, be sure to indicate to the manufacturer the intended use of the antenna and the frequency extremes. In some cases, the only way the manufacturer can accommodate your request is to provide an antenna with some vertical-beam uptilt at one end of the band and some downtilt at the other end of the band. In the case of antennas with very high gain, this in itself may become a serious problem. Careful analysis of the situation is necessary before assembling such a system.

### Diversity Techniques for Repeater

Mobile flutter, “dead spots” and similar problems are a real problem for the mobile operator. The popularity of handheld transceivers using low power and mediocre antennas causes similar problems. A solution to these difficulties is the use of some form of diversity reception. Diversity



**Fig 17**—Block diagram of a system using a transmitter multicoupler to allow a single feed line and antenna to be used by two repeaters on one band. The antenna must be designed to operate at all frequencies that the repeaters utilize. More than two repeaters can be operated this way by using a multicoupler with the appropriate number of input ports.

reception works because signals do not fade at the same rate when received by antennas at different locations (space diversity) or of different polarizations (polarization diversity).

Repeaters with large transmitter coverage areas often have difficulty “hearing” low power stations in peripheral areas or in dead spots. Space diversity is especially useful in such a situation. Space diversity utilizes separate receivers at different locations that are linked to the repeater. The repeater uses a circuit called a *voter* that determines which receiver has the best signal, and then selects the appropriate receiver from which to feed the repeater transmitter. This technique is helpful in urban areas where shadowing from large buildings and bridges causes problems. Space-diversity receiving, when properly executed, can give excellent results. But with the improvement come some disadvantages: added initial cost, maintenance costs, and the possibility of failure created by the extra equipment required. If installed and maintained carefully, problems are generally minimal.

A second improvement technique is the use of circularly polarized repeater antennas. This technique has been used in the FM broadcast field for many years, and has been considered for use in the mobile telephone service as well. Some experiments by amateurs have proved very promising, as discussed by [Pasternak and Morris](#) (see the Bibliography at the end of this chapter).

The improvement afforded by circular polarization is primarily a reduction in mobile flutter. The flutter on a mobile signal is caused by reflections from large buildings (in urban settings) or other terrain features. These reflections cause measurable polarization shifts, sometimes to the point where a vertically polarized signal at the transmitting site may appear to be primarily horizontally polarized after reflection.

A similar situation results from multipath propagation, where one or more reflected signals combine with the direct signal at the repeater, having varying effects on the signal. The multipath signal is subjected to large amplitude and phase variations at a relatively rapid rate.

In both of the situations described here, circular polarization can offer considerable improvement. This is because circularly polarized antennas respond equally to all linearly polarized signals, regardless of the plane of polarization. At this writing, there are no known sources of commercial circularly polarized omnidirectional antennas for the amateur bands. Pasternak and Morris describe a circularly polarized antenna made by modifying two commercial four-pole arrays.

### EFFECTIVE ISOTROPIC RADIATED POWER (EIRP)

It is useful to know effective isotropic radiated power (EIRP) in calculating the coverage area of a repeater. The FCC formerly required EIRP to be entered in the log of every amateur repeater station. Although logging EIRP is no longer required, it is still useful to have this information on hand for repeater coordination purposes and so system performance can be monitored periodically.

Calculation of EIRP is straightforward. The PEP output of the transmitter is simply multiplied by the gains and losses in the transmitting antenna system. (These gains and losses are best added or subtracted in decibels and then converted to a multiplying factor.) The following worksheet and example illustrates the calculations.

Feed-line loss	_____ dB
Duplexer loss	_____ dB
Isolator loss	_____ dB
Cross-band coupler loss	_____ dB
Cavity filter loss	_____ dB
	_____
Total losses (L)	_____ dB

$$G \text{ (dB)} = \text{antenna gain (dBi)} - L$$

where G = antenna system gain. (If antenna gain is specified in dBd, add 2.14 dB to obtain the gain in dBi.)

$$M = 10^{G/10}$$

where M = multiplying factor

$$\text{EIRP (watts)} = \text{transmitter output (PEP)} \times M$$

#### Example

A repeater transmitter has a power output of 50 W PEP (50-W FM transmitter). The transmission line has 1.8 dB loss. The duplexer used has a loss of 1.5 dB, and a circulator on the transmitter port has a loss of 0.3 dB. There are no cavity filters or cross-band couplers in the system. Antenna gain is 5.6 dBi.

Feed-line loss	1.8 dB
Duplexer loss	1.5 dB
Isolator loss	0.3 dB
Cross-band coupler loss	0 dB
Cavity filter loss	0 dB
	_____
Total losses (L)	3.6 dB

$$\text{Antenna system gain in dB} = G = \text{antenna gain (dBi)} - L$$

$$G = 5.6 \text{ dBi} - 3.6 \text{ dB} = 2 \text{ dB}$$

$$\text{Multiplying factor} = M = 10^{G/10}$$

$$M = 10^{2/10} = 1.585$$

$$\text{EIRP (watts)} = \text{transmitter output (PEP)} \times M$$

$$\text{EIRP} = 50 \text{ W} \times 1.585 = 79.25 \text{ W}$$

If the antenna system is lossier than this example, G may be *negative*, resulting in a multiplying factor less than 1. The result is an EIRP that is less than the transmitter output power. This situation can occur in practice, but for obvious reasons is not desirable.

# Assembling a Repeater Antenna System

This section will aid you in planning and assembling your repeater antenna system. The material was prepared by Domenic Mallozzi, N1DM. Consult [Chapter 23](#) for

information on propagation for the band of your interest.

First, a repeater antenna selection checklist such as this will help you in evaluating the antenna system for your needs.

Gain needed	_____ dBi	Is downtilt required?	_____ Yes
Pattern required	_____ Omnidirectional		_____ No
	_____ Offset	Type of RF connector	_____ UHF
	_____ Cardioidal		_____ N
	_____ Bidirectional		_____ BNC
	_____ Special pattern (specify)		_____ Other (specify)
	_____	Size (length)	_____
Mounting	_____ Top of tower	Weight	_____
	_____ Side of tower	Maximum cost	\$ _____
	(Determine effects of tower on pattern. Is the result consistent with the pattern required?)		

**Table 1**  
**Product Matrix Showing Repeater Equipment and Manufacturer by Frequency Band**

Source	Antennas							Duplexers				Cavity Filters			
	28	50	144	222	450	902	1296	144	222	450	902	144	222	450	902
Austin Ant.	S	S	S	S	S	S	S								
Celwave	C	C	C	C	C	C		C	C	C	C	C	C	C	C
Comet			C		C	C	C								
Cushcraft		C	C	C	C										
Dec Prod		C	C	C	C	C		C	C	S	S	C		C	
RF Parts			C	C	C		C								
Sinclair	C	C	C	C				C	C	C		C		C	C
TX/RX								C	C	C		C	C	C	C
Wacom								C	C	C	C	C	C	C	C

Source	Isolators/Circulators						Transmitter Combiners				Cross-Band Couplers			
	28	50	144	222	450	902	144	222	450	902	0-174 450-512	0-512 800-960	50-174 806-960	406-512 806-960
Celwave			C	C	C	C	C	C	C	C		S		
Dec Prod			C		C	C		C	C	C				
Sinclair			C		C	C	C	S		C				
TX/RX			C	C	C	C	C	C	C	C	C	C	C	C
Wacom			C	C	C	C	C	C	C	C	C			C

Abbreviated names above are for the following manufacturers: Austin Antenna, Celwave RF Inc, Cushcraft Corp, Decibel Products Inc, RF Parts, Sinclair Radio Laboratories Inc, TX/RX Systems Inc and Wacom Inc. A manufacturers' contact list appears in [Chapter 21](#).

Key to codes used:

C = in-stock catalog item

S = available special order

Note: Coaxial cable is not listed, because most manufacturers sell only to dealers.

**Table 1** has been compiled to provide general information on commercial components available for repeater and remote-base antenna systems. The various components are listed in a matrix format by manufacturer, for equipment designed to operate in the various amateur bands. See **Chapter 21** for supplier information for these components. Although every effort has been made to make this data complete, the ARRL is not responsible for omissions or errors. The listing of a product in **Table 1** does not constitute an endorsement by the ARRL. Manufacturers are

urged to contact the editors with updating information.

Even though almost any antenna can be used for a repeater, the companies indicated in the *Antennas* column in **Table 1** are known to have produced heavy-duty antennas to commercial standards for repeater service. Many of these companies offer their antennas with special features for repeater service (such as vertical-beam downtilt). It is best to obtain catalogs of current products from the manufacturers listed, both for general information and to determine which special options are available on their products.

## A 144 MHz Duplexer

Obtaining sufficient isolation between the transmitter and receiver of a repeater can be difficult. Many of the solutions to this problem compromise receiver sensitivity or transmitter power output. Other solutions create an imbalance between receiver and transmitter coverage areas. When a duplexer is used, insertion loss is the compromise. But a small amount of insertion loss is more than offset by the use of one antenna for both the transmitter and receiver. Using one antenna assures equal antenna patterns for both transmitting and receiving, and reduces cost, maintenance and mechanical complexity.

As mentioned earlier in this chapter, duplexers may be built in the home workshop. **Bob Shriner, WA0UZO**, presented a small, mechanically simple duplexer for low-power applications in April 1979 *QST*. Shriner's design is unique, as the duplexer cavities are constructed of circuit board material. Low cost and simplicity are the result, but with a trade-off in performance. A silver-plated version of Shriner's design has an insertion loss of approximately 5 dB at 146 MHz. The loss is greater if the copper is not plated, and increases as the inner walls of the cavity tarnish.

This duplexer construction project by **John Bilodeau, WIGAN**, represents an effective duplexer. The information originally appeared in July 1972 *QST*. It is a time proven project used by many repeater groups, and can be duplicated relatively easily. Its insertion loss is just 1.5 dB.

**Fig 18** will help you visualize the requirements for a duplexer, which can be summed up as follows. The duplexer must attenuate the transmitter carrier to avoid overloading the receiver and thereby reducing its sensitivity. It must also attenuate any noise or spurious frequencies from the transmitter on or near the receiver frequency. In addition, a duplexer must provide a proper impedance match between transmitter, antenna, and receiver.

As shown in **Fig 18**, transmitter output on 146.94 MHz going from point C to D should not be attenuated. However, the transmitter energy should be greatly attenuated between points B and A. Duplexer section 2 should attenuate any noise or signals that are on or near the receiver input frequency of 146.34 MHz. For good reception the noise and spurious signal level must be less than -130 dBm (0 dBm = 1 milliwatt into 50 Ω). Typical transmitter noise 600 kHz

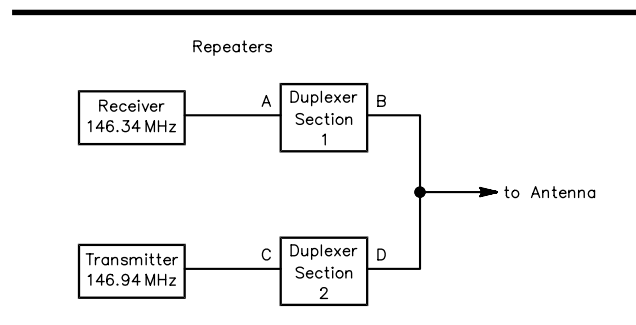
away from the carrier frequency is 80 dB below the transmitter power output. For 60 W of output (+48 dBm), the noise level is -32 dBm. The duplexer must make up the difference between -32 dBm and -130 dBm, or 98 dB.

The received signal must go from point B to A with a minimum of attenuation. Section 1 of the duplexer must also provide enough attenuation of the transmitter energy to prevent receiver overload. For an average receiver, the transmitter signal must be less than -30 dBm to meet this requirement. The difference between the transmitter output of +48 dBm and the receiver overload point of -30 dBm, 78 dB, must be made up by duplexer section 1.

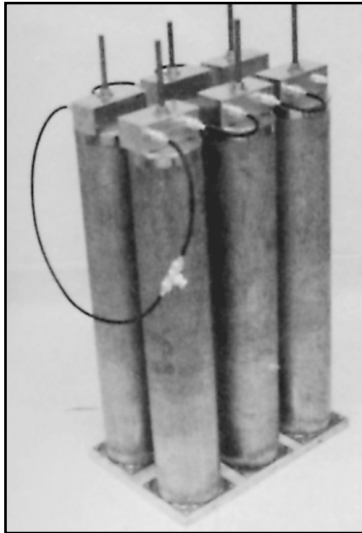
### THE CIRCUIT

**Fig 19** shows the completed six-cavity duplexer, and **Fig 20** shows the assembly of an individual cavity. A  $1/4\lambda$  resonator was selected for this duplexer design. The length of the center conductor is adjusted by turning a threaded rod, which changes the resonant frequency of the cavity. Energy is coupled into and out of the tuned circuit by the coupling loops extending through the top plate.

The cavity functions as a series resonant circuit. When a reactance is connected across a series resonant circuit, an anti-resonant notch is produced, and the resonant frequency is shifted. If a capacitor is added, the notch appears below



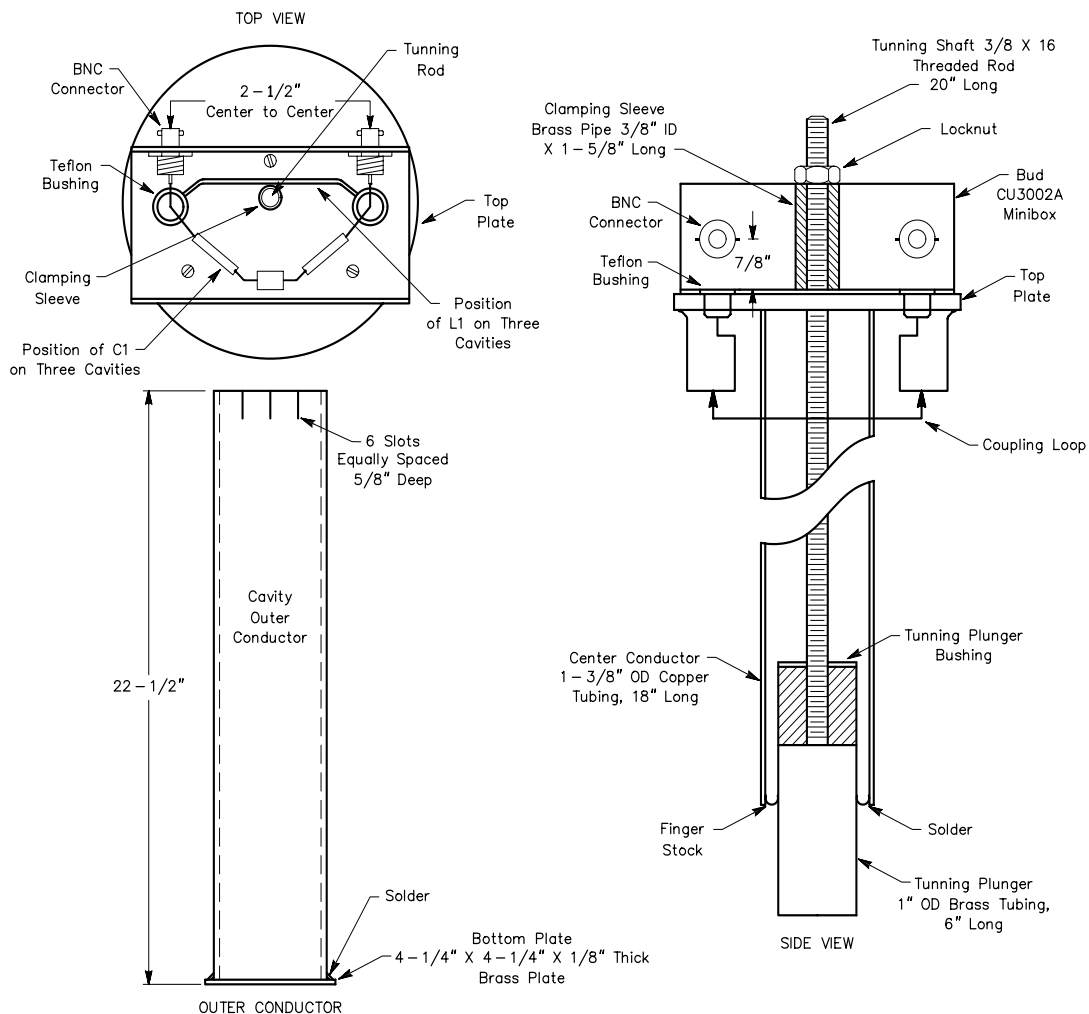
**Fig 18**—Duplexers permit using one antenna for both transmitting and receiving in a repeater system. Section 1 prevents energy at the transmitter frequency from interfering with the receiver, while section 2 attenuates any off-frequency transmitter energy that is at or near the receiver frequency.



**Fig 19—A six-cavity duplexer for use with a 144-MHz repeater. The cavities are fastened to a plywood base for mechanical stability. Short lengths of double-shielded cable are used for connections between individual cavities. An insertion loss of less than 1.5 dB is possible with this design.**

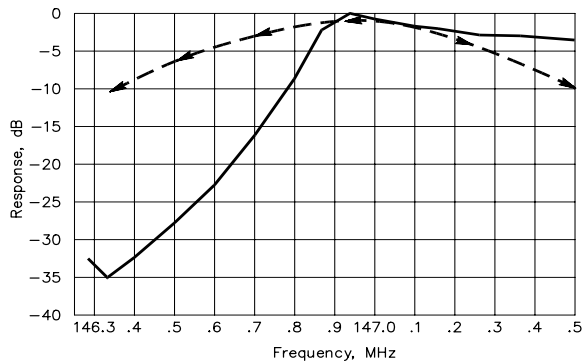
the resonant frequency. Adding inductance instead of capacitance makes the notch appear above the resonant frequency. The value of the added component determines the spacing between the notch and the resonant frequency of the cavity.

**Fig 21** shows the measured band-pass characteristics of the cavity with shunt elements. With the cavity tuned to 146.94 MHz and a shunt capacitor connected from input to output, a 146.34-MHz signal is attenuated by 35 dB. If an inductance is placed across the cavity and the cavity is tuned to 146.34 MHz, the attenuation at 146.94 MHz is 35 dB. Insertion loss in both cases is 0.4 dB. Three cavities with shunt capacitors are tuned to 146.94 MHz and connected together in cascade with short lengths of coaxial cable. The attenuation at 146.34 MHz is more than 100 dB, and insertion loss at 146.94 MHz is 1.5 dB. Response curves for a six-cavity duplexer are given in **Fig 22**.



**Fig 20—The assembly of an individual cavity. A Bud Minibox is mounted on the top plate with three screws. A clamping sleeve made of brass pipe is used to prevent crushing the box when the locknut is tightened on the tuning shaft. Note that the positions of both C1 and L1 are shown, but that three cavities will have C1 installed and three will have L1 in place.**





**Fig 21—Typical frequency response of a single cavity of the type used in the duplexer. The dotted line represents the passband characteristics of the cavity alone; the solid line for the cavity with a shunt capacitor connected between input and output. An inductance connected in the same manner will cause the rejection notch to be above the frequency to which the cavity is tuned.**

### Construction

The schematic diagram for the duplexer is shown in **Fig 23**. Three parts for the duplexer must be machined; all others can be made with hand tools. A small lathe can be used to machine the brass top plate, the threaded tuning plunger bushing, and the Teflon insulator bushing. The dimensions of these parts are given in **Fig 24**.

Type DWV copper tubing is used for the outer conductor

of the cavities. The wall thickness is 0.058 inch, with an outside diameter of  $4\frac{1}{8}$  inches. You will need a tubing cutter large enough to handle this size (perhaps borrowed or rented). The wheel of the cutter should be tight and sharp. Make slow, careful cuts so the ends will be square. The outer conductor is  $22\frac{1}{2}$  inches long.

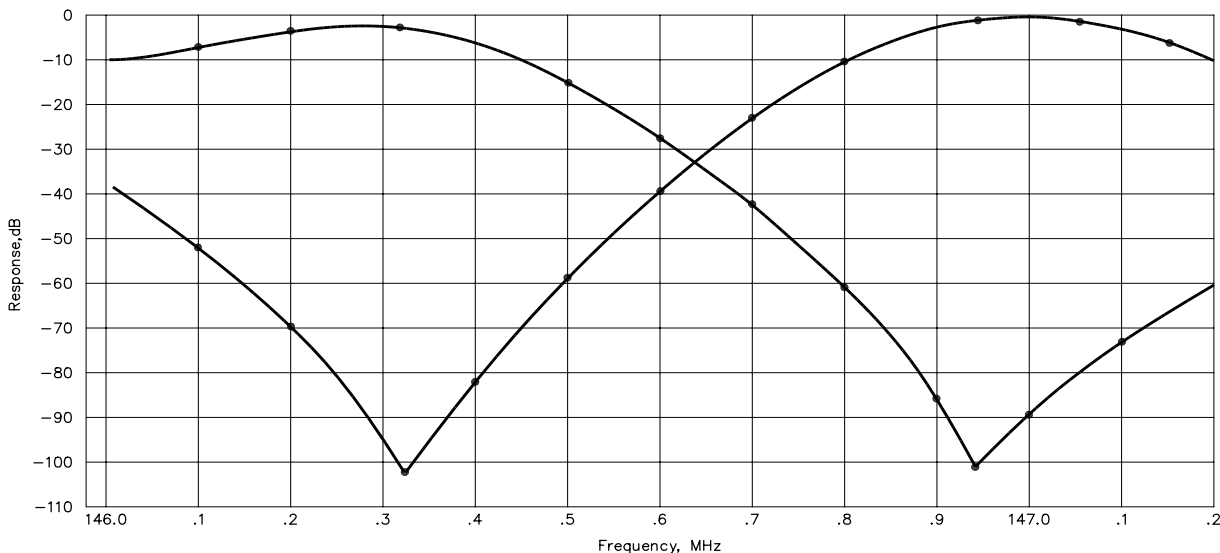
The inner conductor is made from type M copper tubing having an outside diameter of  $1\frac{3}{8}$  inches. A 6-inch length of 1-inch OD brass tubing is used to make the tuning plunger.

The tubing types mentioned above are designations used in the plumbing and steam-fitting industry. Other types may be used in the construction of a duplexer, but you should check the sizes carefully to assure that the parts will fit each other. Tubing with a greater wall thickness will make the assembly heavier, and the expense will increase accordingly.

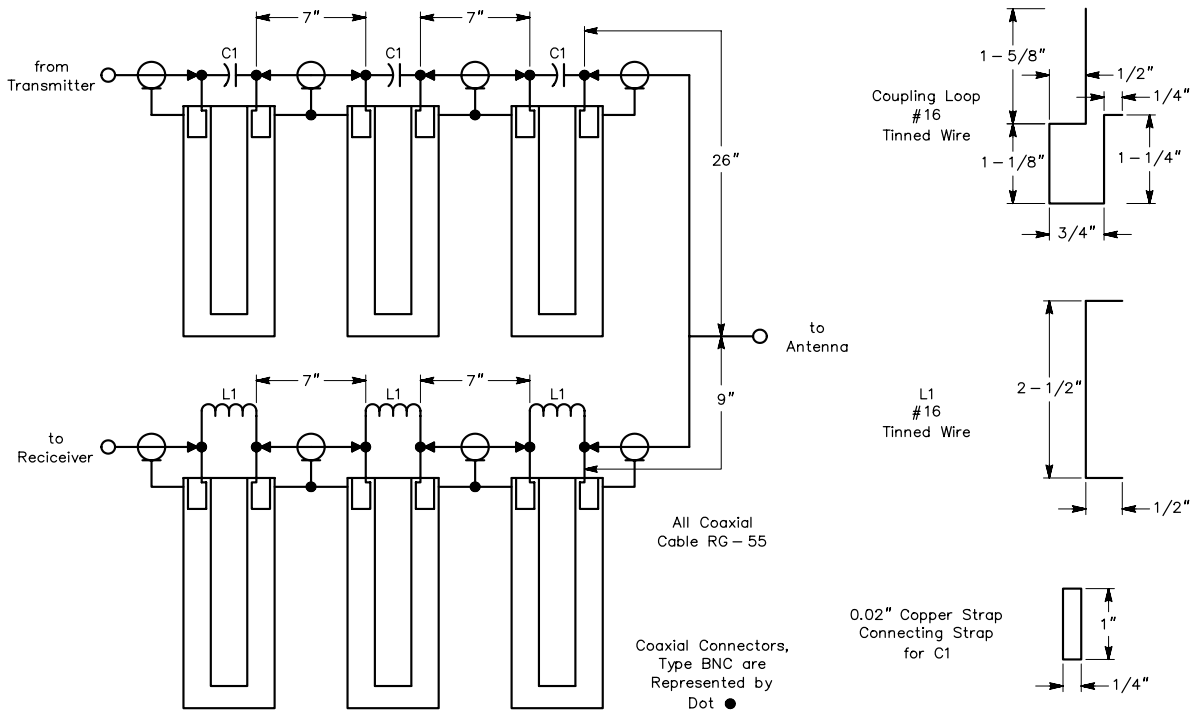
Soft solder is used throughout the assembly. Unless you have experience with silver solder, do not use it. Eutectic type 157 solder with paste or acid flux makes very good joints. This type has a slightly higher melting temperature than ordinary tin-lead alloy, but has considerably greater strength.

First solder the inner conductor to the top plate (**Fig 25**). The finger stock can then be soldered inside the lower end of the inner conductor, while temporarily held in place with a plug made of aluminum or stainless steel. While soldering, do not allow the flame from the torch to overheat the finger stock. The plunger bushing is soldered into the tuning plunger and a 20-inch length of threaded rod is soldered into the bushing.

Cut six slots in the top of the outer conductor. They should be  $\frac{5}{8}$  inch deep and equally spaced around the tubing.

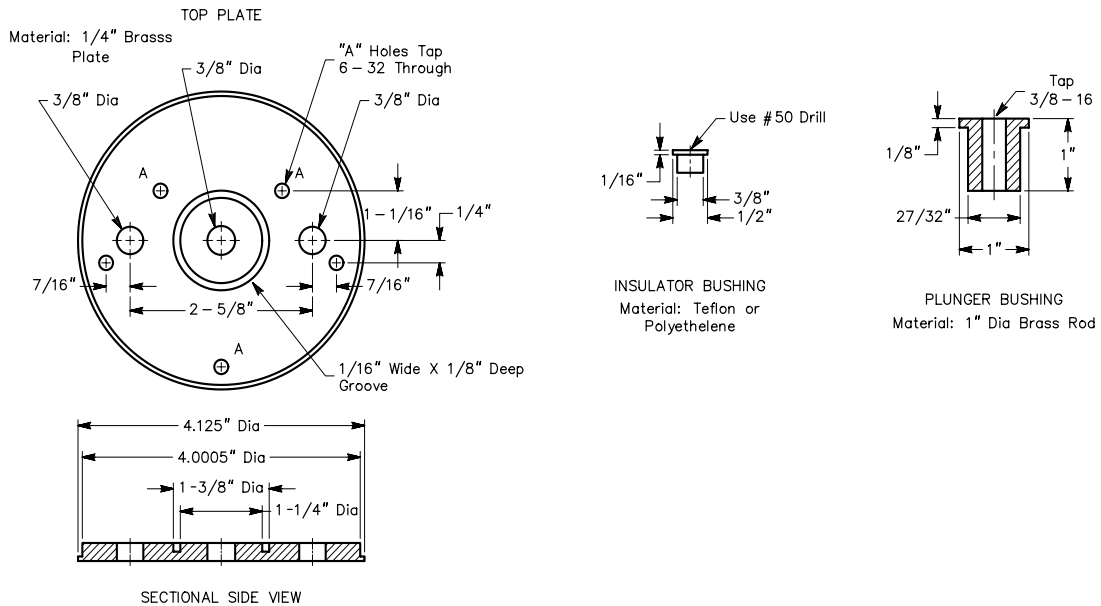


**Fig 22—Frequency response of the six-cavity duplexer. One set of three cavities is tuned to pass 146.34 MHz and notch 146.94 MHz (the receiver leg). The remaining set of three cavities is tuned to pass 146.94 MHz and notch 146.34 MHz. This duplexer provides approximately 100 dB of isolation between the transmitter and receiver when properly tuned.**

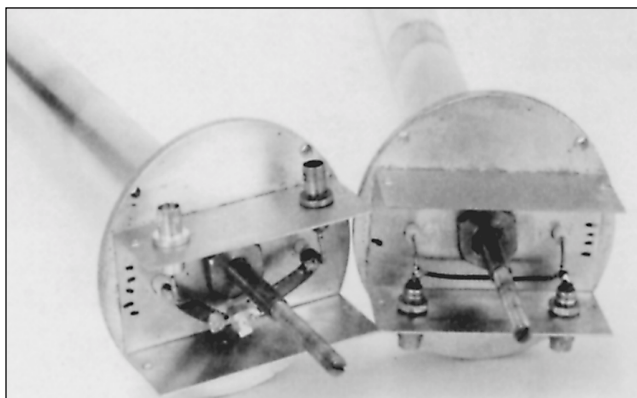


**Fig 23—Diagram of the six-cavity duplexer. Coaxial cable lengths between cavities are critical and must be followed closely. Double shielded cable and high quality connectors should be used throughout. The sizes and shapes of the coupling loops, L1, and the straps for connecting C1 should be observed.**

**C1—1.7-11 pF circuit-board mount, E. F. Johnson 189-5-5 or equiv. Set at 3/4 closed for initial alignment.**



**Fig 24—Dimensions for the three parts that require machining. A small metal-working lathe should be used for making these parts.**



**Fig 25—Two of the center conductor and top plate assemblies. In the assembly at the left, C1 is visible just below the tuning shaft, mounted by short straps made from sheet copper. The assembly on the right has L1 in place between the BNC connectors. The Miniboxes are fastened to the top plate by a single large nut in these units. Using screws through the Minibox into the top plate, as described in the text, is preferred.**

The bottom end of the 4-inch tubing is soldered to the square bottom plate. The bottom plates have holes in the corners so they can be fastened to a plywood base by means of wood screws. Because the center conductor has no support at one end, the cavities must be mounted vertically.

The size and position of the coupling loops are critical. Follow the given dimensions closely. Both loops should be  $\frac{1}{8}$  inch away from the center conductor on opposite sides. Connect a solder lug to the ground end of the loop, then fasten the lug to the top plate with a screw. The free end of the loop is insulated by Teflon bushings where it passes through the top plate for connection to the BNC fittings.

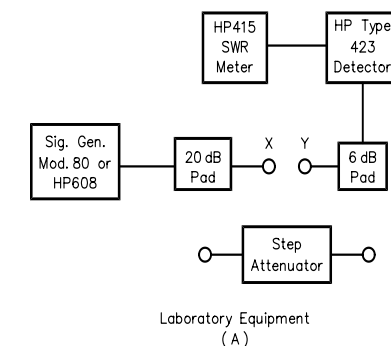
Before final assembly of the parts, clean them thoroughly. Soap-filled steel wool pads and hot water work well for this. Be sure the finger stock makes firm contact with the tuning plunger. The top plate should fit snugly in the top of the outer conductor—a large hose clamp tightened around the outer conductor will keep the top plate in place.

### ADJUSTMENT

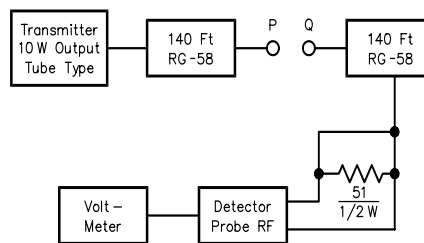
After the cavities have been checked for band-pass characteristics and insertion loss, install the anti-resonant elements, C1 and L1. (See Fig 21.) It is preferable to use laboratory test equipment when tuning the duplexer. An option is to use a low power transmitter with an RF probe and an electronic voltmeter. Both methods are shown in Fig 26.

With the test equipment connected as shown in Fig 26A, adjust the signal generator frequency to the desired repeater input frequency. Connect a calibrated step attenuator between points X and Y. With no attenuation, adjust the HP-415 for 0 on the 20-dB scale. You can check the calibration of the 415 by switching in different amounts of attenuation and noting the meter reading. You may note a small error at either high or very low signal levels.

Next, remove the step attenuator and replace it with a



Laboratory Equipment (A)



Simple Equipment (B)

**Fig 26—The duplexer can be tuned by either of the two methods shown here, although the method depicted at A is preferred. The signal generator should be modulated by a 1-kHz tone. If the setup shown at B is used, the transmitter should not be modulated, and should have a minimum of noise and spurious signals. The cavities to be aligned are inserted between X and Y in the setup at A, and between P and Q in B.**

cavity that has the shunt inductor, L1, in place. Adjust the tuning screw for maximum reading on the 415 meter. Remove the cavity and connect points X and Y. Set the signal generator to the repeater output frequency and adjust the 415 for a 0 reading on the 20-dB scale.

Reinsert the cavity between X and Y and adjust the cavity tuning for minimum reading on the 415. The notch should be sharp and have a depth of at least 35 dB. It is important to maintain the minimum reading on the meter while tightening the locknut on the tuning shaft.

To check the insertion loss of the cavity, the output from the signal generator should be reduced, and the calibration of the 415 meter checked on the 50-dB expanded scale. Use a fixed 1-dB attenuator to make certain the error is less than 0.1 dB. Replace the attenuator with the cavity and read the loss. The insertion loss should be 0.5 dB or less. The procedure is the same for tuning all six cavities, except that the frequencies are reversed for those having the shunt capacitor installed.

### Adjustment with Minimum Equipment

A transmitter with a minimum of spurious output should be used for this method of adjustment. Most modern

transmitters meet this requirement. The voltmeter in use should be capable of reading 0.5 V (or less), full scale. The RF probe used should be rated to 150 MHz or higher. Sections of RG-58 cable are used as attenuators, as shown in Fig 26B. The loss in these 140-foot lengths is nearly 10 dB, and helps to isolate the transmitter in case of mismatch during tuning.

Set the transmitter to the repeater input frequency and connect P and Q. Obtain a reading between 1 and 3 V on the voltmeter. Insert a cavity with shunt capacitors in place between P and Q and adjust the cavity tuning for a minimum reading on the voltmeter. (This reading should be between 0.01 and 0.05 V.) The rejection in dB can be calculated by

$$\text{dB} = 20 \log (V1/V2)$$

This should be at least 35 dB. Check the insertion loss by putting the receiver on the repeater output frequency and noting the voltmeter reading with the cavity out of the circuit.

A 0.5-dB attenuator can be made from a 7-foot length of RG-58. This 7-foot cable can be used to check the calibration of the detector probe and the voltmeter.

Cavities with shunt inductance can be tuned the same way, but with the frequencies reversed. If two or more cavities are tuned while connected together, transmitter noise can cause the rejection readings to be low. In other words, there will be less attenuation.

### Results

The duplexer is conservatively rated at 150 W input, but, if constructed carefully, should be able to handle as much as 300 W. Silver plating the interior surfaces of the cavities is recommended if input power is to be greater than 150 W. A duplexer of this type with silver plated cavities has an insertion loss of less than 1 dB, and a rejection of more than 100 dB. Unplated cavities should be disassembled at least every two years, cleaned thoroughly, and then retuned.

### Miscellaneous Notes

- 1) Double-shielded cable and high-quality connectors are *required* throughout the system.
- 2) The SWR of the antenna should not exceed 1.2:1 for proper duplexer performance.
- 3) Good shielding of the transmitter and receiver at the repeater is essential.
- 4) The antenna should have four or more wavelengths of vertical separation from the repeater.
- 5) Conductors in the near field of the antenna should be well bonded and grounded to eliminate noise.
- 6) The feed line should be electrically bonded and mechanically secured to the tower or mast.
- 7) Feed lines and other antennas in the near field of the repeater antenna should be well bonded and as far from the repeater antenna as possible.
- 8) Individual cavities can be used to improve the performance of separate antenna or separate site repeaters.

- 9) Individual cavities can be used to help solve inter-modulation problems.

### BIBLIOGRAPHY

Source material and more extended discussions of the topics covered in this chapter can be found in the references below.

- P. Arnold, "Controlling Cavity Drift in Low-Loss Combiners," *Mobile Radio Technology*, Apr 1986, pp 36-44.
- L. Barrett, "Repeater Antenna Beam Tilting," *Ham Radio*, May 1983, pp 29-35. (See correction, *Ham Radio*, Jul 1983, p 80.)
- W. F. Biggerstaff, "Operation of Close Spaced Antennas in Radio Relay Systems," *IRE Transactions on Vehicular Communications*, Sep 1959, pp 11-15.
- J. J. Bilodeau, "A Homemade Duplexer for 2-Meter Repeaters," *QST*, Jul 1972, pp 22-26, 47.
- W. B. Bryson, "Design of High Isolation Duplexers and a New Antenna for Duplex Systems," *IEEE Transactions on Vehicular Communications*, Mar 1965, pp 134-140.
- K. Connolly and P. Blevins, "A Comparison of Horizontal Patterns of Skeletal and Complete Support Structures," *IEEE 1986 Vehicular Technology Conference Proceedings*, pp 1-7.
- S. Kozono, T. Tsuruhara and M. Sakamoto, "Base Station Polarization Diversity Reception for Mobile Radio," *IEEE Transactions on Vehicular Technology*, Nov 1984, pp 301-306.
- J. Kraus, *Antennas*, 2nd ed (New York: McGraw-Hill Book Co, 1988).
- W. Pasternak and M. Morris, *The Practical Handbook of Amateur Radio FM & Repeaters* (Blue Ridge Summit, PA: TAB Books Inc., 1980), pp 355-363.
- M. W. Scheldorf, "Antenna-To-Mast Coupling in Communications," *IRE Transactions on Vehicular Communications*, Apr 1959, pp 5-12.
- R. D. Shriner, "A Low Cost PC Board Duplexer," *QST*, Apr 1979, pp 11-14.
- W. V. Tilston, "Simultaneous Transmission and Reception with a Common Antenna," *IRE Transactions on Vehicular Communications*, Aug 1962, pp 56-64.
- E. P. Tilton, "A Trap-Filter Duplexer for 2-Meter Repeaters," *QST*, Mar 1970, pp 42-46.
- R. Wheeler, "Fred's Advice Solves Receiver Desense Problem," *Mobile Radio Technology*, Feb 1986, pp 42-44.
- R. Yang and F. Willis, "Effects of Tower and Guys on Performance of Side Mounted Vertical Antennas," *IRE Transactions on Vehicular Communications*, Dec 1960, pp 24-31.

## Chapter 18

# VHF and UHF Antenna Systems

A good antenna system is one of the most valuable assets available to the VHF/UHF enthusiast. Compared to an antenna of lesser quality, an antenna that is well designed, is built of good quality materials, and is well maintained, will increase transmitting range, enhance reception of weak signals, and reduce interference problems. The work itself is by no means the least

attractive part of the job. Even with high gain antennas, experimentation is greatly simplified at VHF and UHF because the antennas are a physically manageable size. Setting up a home antenna range is within the means of most amateurs, and much can be learned about the nature and adjustment of antennas. No large investment in test equipment is necessary.

## The Basics

Selecting the best VHF or UHF antenna for a given installation involves much more than scanning gain figures and prices in a manufacturer's catalog. There is no one "best" VHF or UHF antenna design for all purposes. The first step in choosing an antenna is figuring out what you want it to do.

### Gain

At VHF and UHF, it is possible to build Yagi antennas with very high gain—15 to 20 dBi—on a physically manageable boom. Such antennas can be combined in arrays of two, four, six, eight, or more antennas. These arrays are attractive for EME, tropospheric scatter or other weak-signal communication modes.

### Radiation Patterns

Antenna radiation can be made omnidirectional, bidirectional, practically unidirectional, or anything between these conditions. A VHF net operator may find an omnidirectional system almost a necessity, but it may be a poor choice otherwise. Noise pickup and other interference problems tend to be greater with such omnidirectional antennas, and such antennas having some gain are especially bad in these respects. Maximum gain and low radiation angle are usually prime interests of the weak signal DX aspirant. A clean pattern, with lowest possible pickup and radiation off the sides and back, may be important in high activity areas, or where the noise level is high.

### Frequency Response

The ability to work over an entire VHF band may be important in some types of work. Modern Yagis can achieve

performance over a remarkably wide frequency range, providing that the boom length is long enough and enough elements are used to populate the boom. Modern Yagi designs in fact are competitive with directly driven collinear arrays of similar size and complexity. The primary performance parameters of gain, front-to-rear ratio and SWR can be optimized over all the VHF or UHF amateur bands readily, with the exception of the full 6-meter band from 50.0 to 54.0 MHz, which has an 8% wide bandwidth. A Yagi can be easily designed to cover any 2.0-MHz portion of the 6-meter band with superb performance.

### Height Gain

In general, the higher the better in VHF and UHF antenna installations. If raising the antenna clears its view over nearby obstructions, it may make dramatic improvements in coverage. Within reason, greater height is almost always worth its cost, but height gain (see [Chapter 23](#)) must be balanced against increased transmission-line loss. This loss can be considerable, and it increases with frequency. The best available line may not be very good if the run is long in terms of wavelengths. Line loss considerations (shown in table form in [Chapter 24](#)) are important in antenna planning.

### Physical Size

A given antenna design for 432 MHz has the same gain as the same design for 144 MHz, but being only one-third as large intercepts only one-ninth as much energy in receiving. In other words, the antenna has less pickup efficiency at 432 MHz. To be equal in communication effectiveness, the 432-MHz array should be at least equal in

size to the 144-MHz antenna, which requires roughly three times as many elements. With all the extra difficulties involved in using the higher frequencies effectively, it is best to keep antennas as large as possible for these bands.

## DESIGN FACTORS

With the objectives sorted out in a general way, decisions on specifics, such as polarization, type of transmission line, matching methods and mechanical design must be made.

### Polarization

Whether to position antenna elements vertically or horizontally has been widely questioned since early VHF pioneering. Tests have shown little evidence as to which polarization sense is most desirable. On long paths, there is no consistent advantage either way. Shorter paths tend to yield higher signal levels with horizontally polarized antennas over some kinds of terrain. Man-made noise, especially ignition interference, also tends to be lower with horizontal antennas. These factors make horizontal polarization somewhat more desirable for weak-signal communications. On the other hand, vertically polarized antennas are much simpler to use in omnidirectional systems and in mobile work.

Vertical polarization was widely used in early VHF work, but horizontal polarization gained favor when directional arrays started to become widely used. The major trend to FM and repeaters, particularly in the 144-MHz band, has tipped the balance in favor of vertical antennas in mobile and repeater use. Horizontal polarization predominates in other communication on 50 MHz and higher frequencies. Additional loss of 20 dB or more can be expected when cross-polarized antennas are used.

## TRANSMISSION LINES

Transmission line principles are covered in detail in [Chapter 24](#). Techniques that apply to VHF and UHF operation are dealt with in greater detail here. The principles of carrying RF from one location to another via a feed line are the same for all radio frequencies. As at HF, RF is carried principally via open-wire lines and coaxial cables at VHF/UHF. Certain aspects of these lines characterize them as good or bad for use above 50 MHz.

Properly built open-wire line can operate with very low loss in VHF and UHF installations. A total line loss under 2 dB per 100 feet at 432 MHz can easily be obtained. A line made of #12 wire, spaced  $\frac{3}{4}$  inch or more with Teflon spreaders and run essentially straight from antenna to station, can be better than anything but the most expensive coax. Such line can be home-made or purchased at a fraction of the cost of coaxial cables, with comparable loss characteristics. Careful attention must be paid to efficient impedance matching if the benefits of this system are to be realized. A similar system for 144 MHz can easily provide a line loss under 1 dB.

Small coax such as RG-58 or RG-59 should never be

used in VHF work if the run is more than a few feet. Lines of  $\frac{1}{2}$ -inch diameter (RG-8 or RG-11) work fairly well at 50 MHz, and are acceptable for 144-MHz runs of 50 feet or less. These lines are somewhat better if they employ foam instead of ordinary PE dielectric material. Aluminum-jacket “Hardline” coaxial cables with large inner conductors and foam insulation are well worth their cost, and can sometimes be obtained for free from local cable TV operators as “end runs”—pieces at the end of a roll. The most common CATV cable is  $\frac{1}{2}$ -inch OD 75- $\Omega$  Hardline. Matched-line loss for this cable is about 1.0 dB/100 feet at 146 MHz and 2.0 dB/100 feet at 432 MHz. Less commonly available from CATV companies is the  $\frac{3}{4}$ -inch 75- $\Omega$  Hardline, sometimes with a black self-healing hard plastic covering. This line has 0.8 dB of loss per 100 feet at 146 MHz, and 1.6 dB loss per 100 feet at 432 MHz. There will be small additional losses for either line if 75 to 50- $\Omega$  transformers are used at each end.

Commercial connectors for Hardline are expensive but provide reliable connections with full waterproofing. Enterprising amateurs have “home-brewed” low-cost connectors. If they are properly waterproofed, connectors and Hardline can last almost indefinitely. Hardline must not be bent too sharply, because it will kink.

Beware of any “bargains” in coax for VHF or UHF use. Feed-line loss can be compensated to some extent by increasing transmitter power, but once lost, a weak signal can never be recovered in the receiver. Effects of weather on transmission lines should not be ignored. Well constructed open-wire line works optimally in nearly any weather, and it stands up well. Twin-lead is almost useless in heavy rain, wet snow or icing. The best grades of coax are completely impervious to weather; they can be run underground, fastened to metal towers without insulation, and bent into any convenient position with no adverse effects on performance.

### G-Line

Conventional two-conductor transmission lines and most coaxial cables are quite lossy in the upper UHF and microwave ranges. If the station and antenna are separated by more than 100 feet, common coaxial cables (such as RG-8) are almost useless for serious work. Unless the very best rigid coax with the proper fittings can be obtained, it is worthwhile to explore alternative methods of carrying RF energy between the station and antenna.

There is a single-conductor transmission line, invented by [Georg Goubau](#) (called “G-Line” in his honor), that can be effectively used in this frequency range. Papers by the inventor appeared some years ago, in which seemingly fantastic claims for line loss were made—under 1 dB per 100 feet in the microwave region, for example. (See the Bibliography at the end of this chapter.) Especially attractive was the statement that the matching device was broadband in nature, making it appear that a single G-Line installation might be made to serve on, say, 432, 903 and 1296 MHz.

The basic idea is that a single conductor can be an almost lossless transmission line at UHF, if a suitable

“launching device” is used. A similar “launcher” is placed at the other end. Basically, the launcher is a cone-shaped device that is a flared extension of the coaxial cable shield. In effect, the cone begins to carry the RF as the outer conductor is gradually “removed.” These launch cones should be at least  $3\lambda$  long. The line should be large and heavily insulated, such as #14, vinyl covered.

Propagation along a G-Line is similar to “ground wave,” or “surface wave” propagation over perfectly conducting earth. The dielectric material confines the energy to the vicinity of the wire, preventing radiation. The major drawback of G-Line is that it is very sensitive to deviation from straight lines. If any bends must be made, they should be in the form of a large radius arc. This is preferable to even an obtuse angle change in the direction of the run. The line must be kept several inches away from metal objects and should be supported with as few insulators as possible.

### WAVEGUIDES

Above 2 GHz, coaxial cable is a losing proposition for communication work. Fortunately, at this frequency the wavelength is short enough to allow practical, efficient energy transfer by an entirely different means. A *waveguide* is a conducting tube through which energy is transmitted in the form of electromagnetic waves. The tube is not considered as carrying a current in the same sense that the wires of a two-conductor line do, but rather as a *boundary* that confines the waves in the enclosed space. Skin effect prevents any electromagnetic effects from being evident outside the guide. The energy is injected at one end, either through capacitive or inductive coupling or by radiation, and is removed from the other end in a like manner. Waveguide merely confines the energy of the fields, which are propagated through it to the receiving end by means of reflections against its inner walls.

Analysis of waveguide operation is based on the assumption that the guide material is a perfect conductor of electricity. Typical distributions of electric and magnetic fields in a rectangular guide are shown in Fig 1. The intensity of the electric field is greatest (as indicated by closer spacing of the lines of force) at the center along the X dimension (Fig 1C), diminishing to zero at the end walls. The fields must diminish in this manner, because the existence of any electric field parallel to the walls at the surface would cause an infinite current to flow in a perfect conductor. Waveguides, of course, cannot carry RF in this fashion.

#### Modes of Propagation

Fig 1 represents the most basic distribution of the electric and magnetic fields in a waveguide. There are an infinite number of ways in which the fields can arrange themselves in a waveguide (for frequencies above the low cutoff frequency of the guide in use). Each of these field configurations is called a *mode*.

The modes may be separated into two general groups. One group, designated *TM* (transverse magnetic), has the magnetic field entirely transverse to the direction of

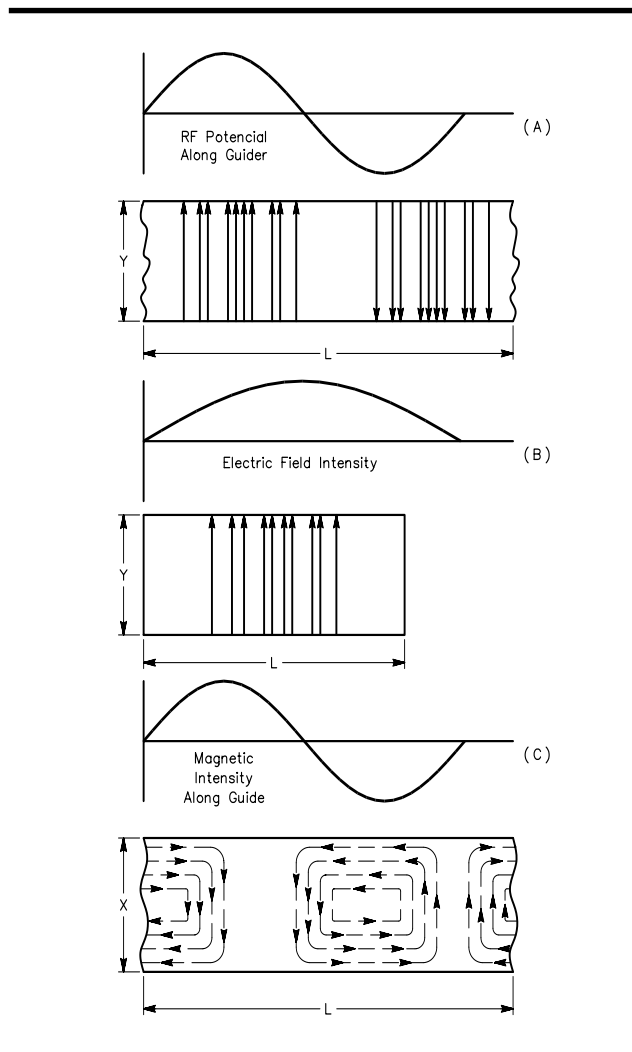


Fig 1—Field distribution in a rectangular waveguide. The  $TE_{10}$  mode of propagation is depicted.

propagation, but has a component of the electric field in that direction. The other type, designated *TE* (transverse electric) has the electric field entirely transverse, but has a component of magnetic field in the direction of propagation. TM waves are sometimes called E waves, and TE waves are sometimes called H waves, but the TM and TE designations are preferred.

The mode of propagation is identified by the group letters followed by two subscript numerals. For example,  $TE_{10}$ ,  $TM_{11}$ , etc. The number of possible modes increases with frequency for a given size of guide, and there is only one possible mode (called the *dominant mode*) for the lowest frequency that can be transmitted. The dominant mode is the one generally used in amateur work.

#### Waveguide Dimensions

In rectangular guide the critical dimension is X in Fig 1. This dimension must be more than  $\frac{1}{2}\lambda$  at the lowest frequency to be transmitted. In practice, the Y dimension

usually is made about equal to  $\frac{1}{2} X$  to avoid the possibility of operation in other than the dominant mode.

Cross-sectional shapes other than the rectangle can be used, the most important being the circular pipe. Much the same considerations apply as in the rectangular case.

Wavelength dimensions for rectangular and circular guides are given in **Table 1**, where  $X$  is the width of a rectangular guide and  $r$  is the radius of a circular guide. All figures apply to the dominant mode.

### Coupling to Waveguides

Energy may be introduced into or extracted from a waveguide or resonator by means of either the electric or magnetic field. The energy transfer frequently is through a coaxial line. Two methods for coupling to coaxial line are shown in **Fig 2**. The probe shown at A is simply a short extension of the inner conductor of the coaxial line, oriented so that it is parallel to the electric lines of force. The loop shown at B is arranged so that it encloses some of the magnetic lines of force. The point at which maximum coupling is obtained depends on the mode of propagation in the guide or cavity. Coupling is maximum when the coupling device is in the most intense field.

Coupling can be varied by turning the probe or loop through a  $90^\circ$  angle. When the probe is perpendicular to the electric lines the coupling is minimum; similarly, when the plane of the loop is parallel to the magnetic lines the coupling is minimum.

If a waveguide is left open at one end it will radiate energy. This radiation can be greatly enhanced by flaring

the waveguide to form a pyramidal horn antenna. The horn acts as a transition between the confines of the waveguide and free space. To effect the proper impedance transformation the horn must be at least  $\frac{1}{2} \lambda$  on a side. A horn of this dimension (cutoff) has a unidirectional radiation pattern with a null toward the waveguide transition. The gain at the cutoff frequency is 3 dB, increasing 6 dB with each doubling of frequency. Horns are used extensively in microwave work, both as primary radiators and as feed elements for elaborate focusing systems. Details for constructing 10-GHz horn antennas are given later in this chapter.

### Evolution of a Waveguide

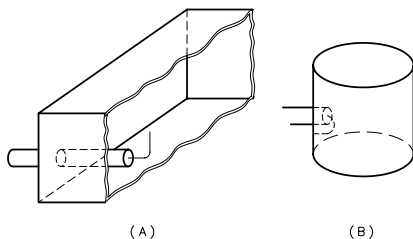
Suppose an open wire line is used to carry RF energy from a generator to a load. If the line has any appreciable length it must be mechanically supported. The line must be well insulated from the supports if high losses are to be avoided. Because high quality insulators are difficult to construct at microwave frequencies, the logical alternative is to support the transmission line with  $\frac{1}{4}\lambda$  stubs, shorted at the end opposite the feed line. The open end of such a stub presents an infinite impedance to the transmission line, provided the shorted stub is nonreactive. However, the shorting link has a finite length, and therefore some inductance. The effect of this inductance can be removed by making the RF current flow on the surface of a plate rather than a thin wire. If the plate is large enough, it will prevent the magnetic lines of force from encircling the RF current.

An infinite number of these  $\frac{1}{4}\lambda$  stubs may be connected in parallel without affecting the standing waves of voltage and current. The transmission line may be supported from the top as well as the bottom, and when an infinite number of supports are added, they form the walls of a waveguide at its cutoff frequency. **Fig 3** illustrates how a rectangular waveguide evolves from a two-wire parallel transmission line as described. This simplified analysis also shows why the cutoff dimension is  $\frac{1}{2} \lambda$ .

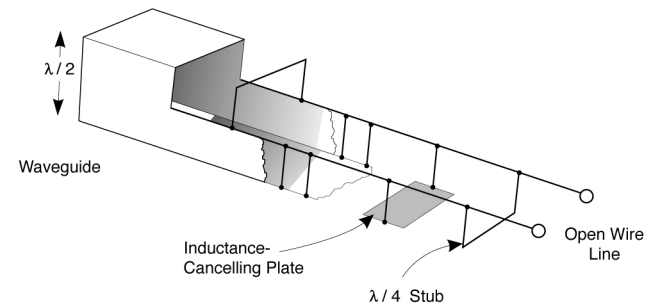
While the operation of waveguides is usually described

**Table 1**  
**Waveguide Dimensions**

	<i>Rectangular</i>	<i>Circular</i>
Cutoff wavelength	$2X$	$3.41r$
Longest wavelength transmitted with little attenuation	$1.6X$	$3.2r$
Shortest wavelength before next mode becomes possible	$1.1X$	$2.8r$



**Fig 2—Coupling coaxial line to waveguide and resonators.**



**Fig 3—At its cutoff frequency a rectangular waveguide can be thought of as a parallel two-conductor transmission line supported from top and bottom by an infinite number of  $\frac{1}{4}\lambda$  stubs.**



in terms of fields, current does flow on the inside walls, just as on the conductors of a two-wire transmission line. At the waveguide cutoff frequency, the current is concentrated in the center of the walls, and disperses toward the floor and ceiling as the frequency increases.

### IMPEDANCE MATCHING

Impedance matching is covered in detail in Chapters 25 and 26, and the theory is the same for frequencies above 50 MHz. Practical aspects are similar, but physical size can be a major factor in the choice of methods. Only the matching devices used in practical construction examples later in this chapter are discussed in detail here. This should not rule out consideration of other methods, however, and a reading of relevant portions of both Chapters 25 and 26 is recommended.

#### Universal Stub

As its name implies, the double adjustment stub of Fig 4A is useful for many matching purposes. The stub length is varied to resonate the system, and the transmission line attachment point is varied until the transmission line and stub impedances are equal. In practice this involves moving both the sliding short and the point of line connection for zero reflected power, as indicated on an SWR bridge connected in the line.

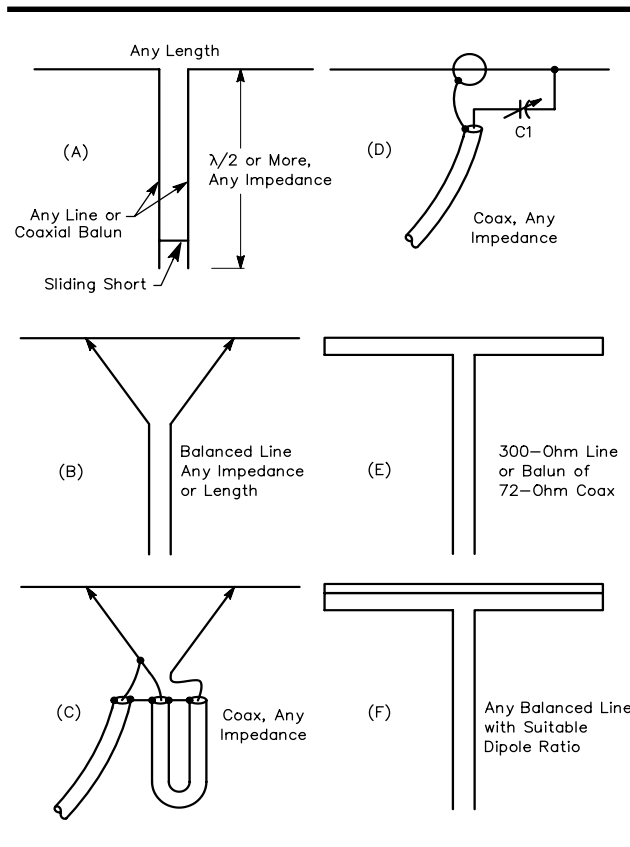
The universal stub allows for tuning out any small reactance present in the driven part of the system. It permits matching the antenna to the line without knowledge of the actual impedances involved. The position of the short yielding the best match gives some indication of the amount of reactance present. With little or no reactive component to be tuned out, the stub must be approximately  $\frac{1}{2} \lambda$  from load toward the short.

The stub should be made of stiff bare wire or rod, spaced no more than  $\frac{1}{20} \lambda$  apart. Preferably it should be mounted rigidly, on insulators. Once the position of the short is determined, the center of the short can be grounded, if desired, and the portion of the stub no longer needed can be removed.

It is not necessary that the stub be connected directly to the driven element. It can be made part of an open wire line, as a device to match coaxial cable to the line. The stub can be connected to the lower end of a delta match or placed at the feed point of a phased array. Examples of these uses are given later.

#### Delta Match

Probably the most basic impedance matching device is the delta match, fanned ends of an open wire line tapped onto a  $\frac{1}{2}\lambda$ -antenna at the point of most efficient power transfer. This is shown in Fig 4B. Both the side length and the points of connection either side of the center of the element must be adjusted for minimum reflected power on the line, but as with the universal stub, the impedances need not be known. The delta match makes no provision for tuning



**Fig 4—Matching methods commonly used at VHF. The universal stub, A, combines tuning and matching. The adjustable short on the stub and the points of connection of the transmission line are adjusted for minimum reflected power on the line. In the delta match, B and C, the line is fanned out and connected to the dipole at the point of optimum impedance match. Impedances need not be known in A, B or C. The gamma match, D, is for direct connection of coax. C1 tunes out inductance in the arm. A folded dipole of uniform conductor size, E, steps up antenna impedance by a factor of four. Using a larger conductor in the unbroken portion of the folded dipole, F, gives higher orders of impedance transformation.**

out reactance, so the universal stub is often used as a termination for it, to this end.

At one time, the delta match was thought to be inferior for VHF applications because of its tendency to radiate if improperly adjusted. The delta has come back into favor now that accurate methods are available for measuring the effects of matching. It is very handy for phasing multiple bay arrays with open wire lines, and its dimensions in this use are not particularly critical. It should be checked out carefully in applications like that of Fig 4C, where no tuning device is used.

#### Gamma and T Matches

An application of the same principle allowing direct connection of coax is the gamma match, Fig 4D. Because

the RF voltage at the center of a  $\frac{1}{2}\lambda$  dipole is zero, the outer conductor of the coax is connected to the element at this point. This may also be the junction with a metallic or wooden boom. The inner conductor, carrying the RF current, is tapped out on the element at the matching point. Inductance of the arm is tuned out by means of C1, resulting in electrical balance. Both the point of contact with the element and the setting of the capacitor are adjusted for zero reflected power, with a bridge connected in the coaxial line.

The capacitance can be varied until the required value is found, and the variable capacitor replaced with a fixed unit of that value. C1 can be mounted in a waterproof box. The maximum required value should be about 100 pF for 50 MHz and 35 to 50 pF for 144 MHz.

The capacitor and arm can be combined in one coaxial assembly with the arm connected to the driven element by means of a sliding clamp, and the inner end of the arm sliding inside a sleeve connected to the center conductor of the coax. An assembly of this type can be constructed from concentric pieces of tubing, insulated by plastic or heat-shrink sleeving. RF voltage across the capacitor is low when the match is adjusted properly, so with a good dielectric, insulation presents no great problem. The initial adjustment should be made with low power. A clean, permanent high conductivity bond between arm and element is important, as the RF current is high at this point.

Because it is inherently somewhat unbalanced, the gamma match can sometimes introduce pattern distortion, particularly on long-boom, highly directive Yagi arrays. The T match, essentially two gamma matches in series creating a balanced feed system, has become popular for this reason. A coaxial balun like that shown in Fig 5 is used from the 200- $\Omega$  balanced T match to the unbalanced 50- $\Omega$  coaxial line going to the transmitter. See [K1FO Yagi designs](#) later in this chapter for details.

### Folded Dipole

The impedance of a  $\frac{1}{2}\lambda$  antenna broken at its center is about 70  $\Omega$ . If a single conductor of uniform size is folded to make a  $\frac{1}{2}\lambda$  dipole as shown in Fig 4E, the impedance is stepped up four times. Such a folded dipole can be fed directly with 300- $\Omega$  line with no appreciable mismatch. If a

4:1 balun is used, the antenna can be fed with 75- $\Omega$  coaxial cable. (See balun information presented below.) Higher step-up impedance transformation can be obtained if the unbroken portion is made larger in cross-section than the fed portion, as shown in Fig 4F.

### Hairpin Match

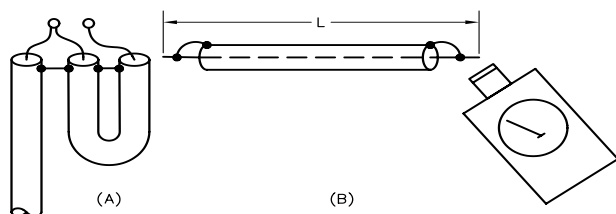
The feed-point resistance of most multi-element Yagi arrays is less than 50  $\Omega$ . If the driven element is split and fed at the center, it may be shortened from its resonant length to add capacitive reactance at the feed point. Then, shunting the feed point with a wire loop resembling a *hairpin* causes a step-up of the feed-point resistance. The hairpin match is used together with a 4:1 coaxial balun in the 50-MHz arrays described later in this chapter.

## BALUNS AND TRANSMATCHES

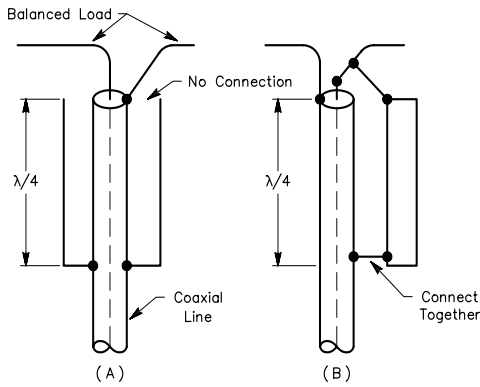
Conversion from balanced loads to unbalanced lines (or vice versa) can be performed with electrical circuits, or their equivalents made of coaxial cable. A balun made from flexible coax is shown in Fig 5A. The looped portion is an electrical  $\frac{1}{2}\lambda$ . The physical length depends on the velocity factor of the line used, so it is important to check its resonant frequency as shown in Fig 5B. The two ends are shorted, and the loop at one end is coupled to a dip meter coil. This type of balun gives an impedance step-up of 4:1 (typically 50 to 200  $\Omega$ , or 75 to 300  $\Omega$ ).

Coaxial baluns that yield 1:1 impedance transformations are shown in Fig 6. The coaxial sleeve, open at the top and connected to the outer conductor of the line at the lower end (A) is the preferred type. At B, a conductor of approximately the same size as the line is used with the outer conductor to form a  $\frac{1}{4}\lambda$  stub. Another piece of coax, using only the outer conductor, will serve this purpose. Both baluns are intended to present an infinite impedance to any RF current that might otherwise flow on the outer conductor of the coax.

The functions of the balun and the impedance transformer can be handled by various tuned circuits. Such a device, commonly called an *antenna tuner* or *Transmatch*, can provide a wide range of impedance transformations. Additional selectivity inherent in the Transmatch can reduce RFI problems.



**Fig 5—Conversion from unbalanced coax to a balanced load can be done with a  $\frac{1}{2}\lambda$  coaxial balun at A. Electrical length of the looped section should be checked with a dip meter, with the ends shorted, as at B. The  $\frac{1}{2}\lambda$  balun gives a 4:1 impedance step-up.**



**Fig 6—The balun conversion function, with no impedance transformation, can be accomplished with  $\lambda/4$ - $\lambda$  lines, open at the top and connected to the coax outer conductor at the bottom. The coaxial sleeve at A is preferred.**

### THE YAGI AT VHF AND UHF

Without doubt, the Yagi is king of home-station antennas these days. Today's best designs are computer optimized. For years amateurs as well as professionals designed Yagi arrays experimentally. Now we have powerful (and inexpensive) personal computers and sophisticated software for antenna modeling. These have brought us antennas with improved performance, with little or no element pruning required. The [chapter on HF Yagis](#) in this handbook describes the parameters associated with Yagi-Uda arrays. Except for somewhat tighter dimensional tolerances needed at VHF and UHF, the properties that make a good Yagi at HF also are needed on the higher frequencies. See the end of this chapter for practical Yagi designs.

### STACKING YAGIS

Where suitable provision can be made for supporting them, two Yagis mounted one above the other and fed in phase can provide better performance than one long Yagi with the same theoretical or measured gain. The pair occupies

a much smaller turning space for the same gain, and their lower radiation angle can provide excellent results. The wider azimuthal coverage for a vertical stack often results in QSOs that might be missed with a single narrow-beam long-boom Yagi pointed in a different direction. On long ionospheric paths, a stacked pair occasionally may show an *apparent* gain much greater than the measured 2 to 3 dB of stacking gain.

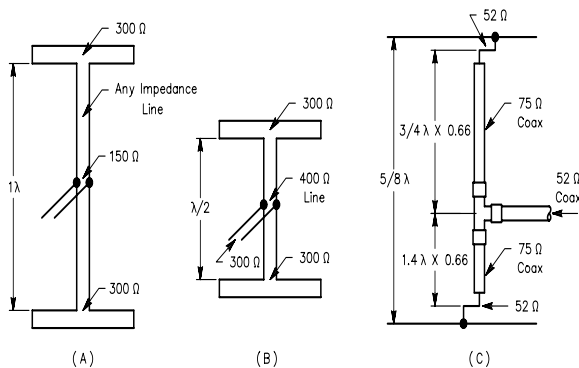
Optimum vertical spacing for Yagis with boom longer than  $1 \lambda$  or more is about  $1 \lambda$  ( $984/50.1 = 19.64$  feet), but this may be too much for many builders of 50-MHz antennas to handle. Worthwhile results can be obtained with as little as  $\frac{1}{2} \lambda$  (10 feet), but  $\frac{5}{8} \lambda$  (12 feet) is markedly better. The difference between 12 and 20 feet may not be worth the added structural problems involved in the wider spacing, at least at 50 MHz. The closer spacings give lower measured gain, but the antenna patterns are cleaner in both azimuth and elevation than with  $1 \lambda$  spacing. Extra gain with wider spacings is usually the objective on 144 MHz and the higher frequency bands, where the structural problems are not as severe.

Yagis can also be stacked in the same plane (collinear elements) for sharper azimuthal directivity. A spacing of  $\frac{5}{8} \lambda$  between the ends of the inner elements yields the maximum gain within the main lobe of the array.

If individual antennas of a stacked array are properly designed, they look like noninductive resistors to the phasing system that connects them. The impedances involved can thus be treated the same as resistances in parallel.

Three sets of stacked dipoles are shown in **Fig 7**. Whether these are merely dipoles or the driven elements of Yagi arrays makes no difference for the purpose of these examples. Two 300- $\Omega$  antennas at A are  $1 \lambda$  apart, resulting in a feed-point impedance of approximately 150  $\Omega$  at the center. (Actually it is slightly less than 150  $\Omega$  because of coupling between bays, but this can be neglected for illustrative purposes.) This value remains the same regardless of the impedance of the phasing line. Thus, any convenient line can be used for phasing, as long as the *electrical* length of each line is the same.

The velocity factor of the line must be taken into



**Fig 7—Three methods of feeding stacked VHF arrays. A and B are for bays having balanced driven elements, where a balanced phasing line is desired. Array C has an all-coaxial matching and phasing system. If the lower section is also  $\frac{3}{4} \lambda$  no transposition of line connections is needed.**

account as well. As with coax, this is subject to so much variation that it is important to make a resonance check on the actual line used. The method for doing this is shown in Fig 5B. A  $\frac{1}{2}\lambda$  line is resonant both open and shorted, but the shorted condition (both ends) is usually the more convenient test condition.

The impedance transforming property of a  $\frac{1}{4}\lambda$  line section can be used in combination matching and phasing lines, as shown in Fig 7B and C. At B, two bays spaced  $\frac{1}{2}\lambda$  apart are phased and matched by a 400- $\Omega$  line, acting as a double Q section, so that a 300  $\Omega$  main transmission line is matched to two 300- $\Omega$  bays. The two halves of this phasing line could also be  $\frac{3}{4}\lambda$  or  $\frac{5}{4}\lambda$  long, if such lengths serve a useful mechanical purpose. (An example is the stacking of two Yagis where the desirable spacing is more than  $\frac{1}{2}\lambda$ .)

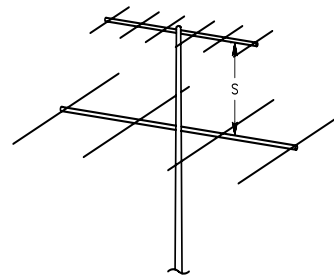
A double Q section of coaxial line is illustrated in Fig 7C. This is useful for feeding stacked bays that were designed for 50- $\Omega$  feed. A spacing of  $\frac{5}{8}\lambda$  is useful for small Yagis, and this is the equivalent of a full electrical wavelength of solid-dielectric coax such as RG-11.

If one phasing line is electrically  $\frac{1}{4}\lambda$  and  $\frac{3}{4}\lambda$  on the other, the connection to one driven element should be reversed with respect to the other to keep the RF currents in the elements in phase—the gamma match is located on opposite sides of the driven elements in Fig 7C. If the number of  $\frac{1}{4}\lambda$  lengths is the same on either side of the feed point, the two connections should be in the same position, and not reversed. Practically speaking, however, you can ensure proper phasing by using exactly equal lengths of line from the same roll of coax. This ensures that the velocity factor for each line is identical.

One marked advantage of coaxial phasing lines is that they can be wrapped around the vertical support, taped or grounded to it, or arranged in any way that is mechanically convenient. The spacing between bays can be set at the most desirable value, and the phasing lines placed anywhere necessary.

In stacking horizontal Yagis one above the other on a single support, certain considerations apply whether the bays are for different bands or for the same band. As a rule of thumb, the minimum desirable spacing is half the boom length for two bays on the same band, or half the boom length of the higher frequency array where two bands are involved.

Assume the stacked two-band array of Fig 8 is for 50 and 144 MHz. The 50-MHz, 4-element Yagi is going to tend to look like “ground” to the 7-element 144-MHz Yagi above it, if it has any effect at all. It is well known that the impedance of an antenna varies with height above ground, passing through the free-space value at  $\frac{1}{4}\lambda$  and multiples thereof. At  $\frac{1}{4}\lambda$  and at the *odd* multiples thereof, ground also acts like a reflector, causing considerable radiation straight up. This effect is least at the  $\frac{1}{2}\lambda$  points, where the impedance also passes through the free-space value. Preferably, then, the spacing S should be  $\frac{1}{2}\lambda$ , or multiple thereof, at the frequency of the smaller antenna. The “half the boom length” rule gives about the same answer in this



**Fig 8—In stacking Yagi arrays one above the other, the minimum spacing between bays (S) should be about half the boom length of the smaller array. Wider spacing is desirable, in which case it should be  $\frac{1}{2}\lambda$ , or some multiple thereof, at the frequency of the smaller array. If the beams shown are for 50 and 144 MHz, S should be at least 40 inches, but 80 inches is preferred. Similar conditions apply for stacking antennas for a single band.**

example. For this size 144-MHz antenna, 40 inches is the minimum desirable spacing, but 80 inches would be better.

The effect of spacing on the larger (lower frequency) array is usually negligible. If spacing closer than half the boom length or  $\frac{1}{2}\lambda$  must be used, the principal concern is variation in feed impedance of the higher frequency antenna. If this antenna has an adjustable matching device, closer spacings can be used in a pinch, if the matching is adjusted for best SWR. Very close spacing and interlacing of elements should be avoided unless the builder is prepared to go through an extensive program of adjustments of both matching and element lengths.

### QUADS FOR VHF

The quad antenna can be built of very inexpensive materials, yet its performance is comparable to other arrays of its size. Adjustment for resonance and impedance matching can be accomplished readily. Quads can be stacked horizontally and vertically to provide high gain, without sharply limiting frequency response. Construction of [quad antennas for VHF use](#) is covered later in this chapter.

### Stacking Quads

Quads can be mounted side by side or one above the other, or both, in the same general way as other antennas. Sets of driven elements can also be mounted in front of a screen reflector. The recommended spacing between adjacent element sides is  $\frac{1}{2}\lambda$ . Phasing and feed methods are similar to those employed with other antennas described in this chapter.

### Adding Directors

Parasitic elements ahead of the driven element work in a manner similar to those in a Yagi array. Closed loops can be used for directors by making them 5% shorter than the

driven element. Spacings are similar to those for conventional Yagis. In an experimental model the reflector was spaced  $0.25 \lambda$  and the director  $0.15 \lambda$ . A square array using four 3-element bays worked extremely well.

### VHF AND UHF QUAGIS

At higher frequencies, especially 420 MHz and above, Yagi arrays using dipole-driven elements are difficult to feed and match, unless special care is taken to keep the feed-point impedance relatively high by proper element spacing and tuning. The cubical quad described earlier overcomes the feed problems to some extent. When many parasitic elements are used, however, the loops are not nearly as convenient to assemble and tune as are straight cylindrical ones used in conventional Yagis. The *Quagi*, designed and popularized by [Wayne Overbeck, N6NB](#), is an antenna having a full-wave loop driven element and reflector, and Yagi type straight rod directors. Construction details and examples are given in the projects later in this chapter.

### COLLINEAR ANTENNAS

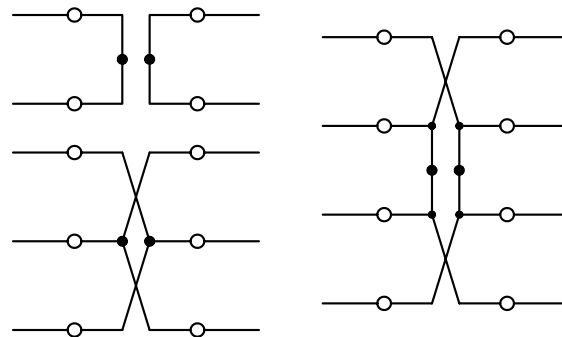
The information given earlier in this chapter pertains mainly to parasitic arrays, but the collinear array is worthy of consideration in VHF/UHF operations. This array tends to be tolerant of construction tolerances, making it easy to build and adjust for VHF applications. The use of many collinear driven elements was once popular in very large phased arrays, such as those required in moonbounce (EME) communication, but the advent of computer-optimized Yagis has changed this in recent years.

#### Large Collinear Arrays

Bidirectional curtain arrays of four, six, and eight half waves in phase are shown in **Fig 9**. Usually reflector elements are added, normally at about  $0.2 \lambda$  behind each driven element, for more gain and a unidirectional pattern. Such parasitic elements are omitted from the sketch in the interest of clarity.

The feed-point impedance of two half waves in phase is high, typically  $1000 \Omega$  or more. When they are combined in parallel and parasitic elements are added, the feed impedance is low enough for direct connection to open wire line or twin-lead, connected at the points indicated by black dots. With coaxial line and a balun, it is suggested that the universal stub match, **Fig 4A**, be used at the feed point. All elements should be mounted at their electrical centers, as indicated by open circles in **Fig 9**. The framework can be metal or insulating material. The metal supporting structure is entirely behind the plane of the reflector elements. Sheet-metal clamps can be cut from scraps of aluminum for this kind of assembly. Collinear elements of this type should be mounted at their centers (where the RF voltage is zero), rather than at their ends, where the voltage is high and insulation losses and detuning can be harmful.

Collinear arrays of 32, 48, 64 and even 128 elements can give outstanding performance. Any collinear array should be fed at the center of the system, to ensure balanced



**Fig 9—Element arrangements for 8, 12 and 16-element collinear arrays. Elements are  $\frac{1}{2} \lambda$  long and spaced  $\frac{1}{2} \lambda$ . Parasitic reflectors, omitted here for clarity, are 5% longer and  $0.2 \lambda$  behind the driven elements. Feed points are indicated by black dots. Open circles show recommended support points. The elements can run through wood or metal booms, without insulation, if supported at their centers in this way. Insulators at the element ends (points of high RF voltage) detune and unbalance the system.**

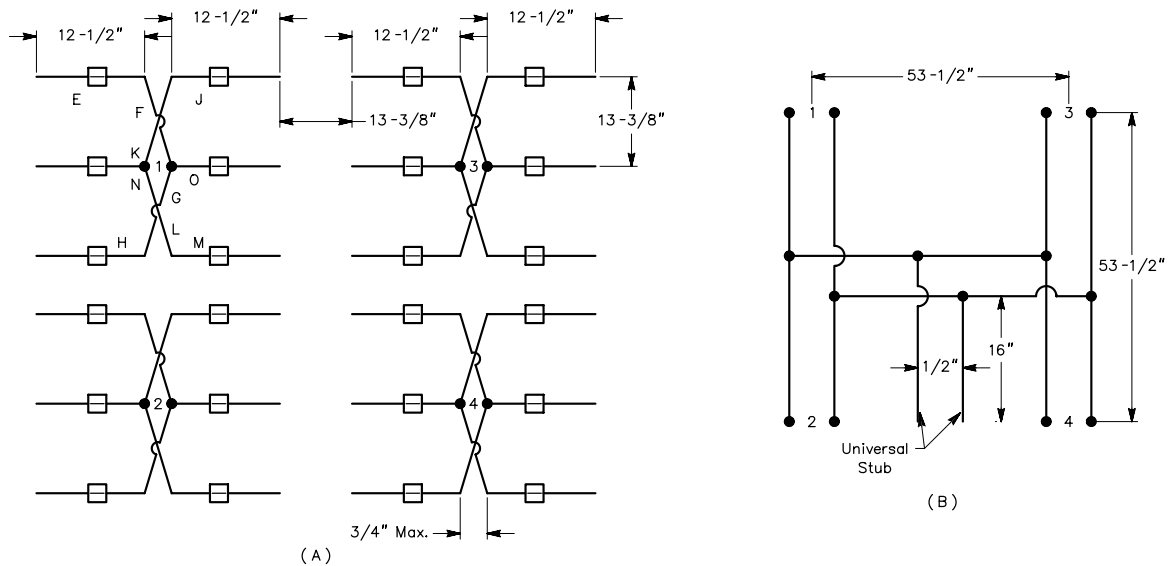
current distribution. This is very important in large arrays, where sets of six or eight driven elements are treated as “sub arrays,” and are fed through a balanced harness. The sections of the harness are resonant lengths, usually of open wire line. The 48-element collinear array for 432 MHz in **Fig 10** illustrates this principle.

A reflecting plane, which may be sheet metal, wire mesh, or even closely spaced elements of tubing or wire, can be used in place of parasitic reflectors. To be effective, the plane reflector must extend on all sides to at least  $\frac{1}{4} \lambda$  beyond the area occupied by the driven elements. The plane reflector provides high F/B ratio, a clean pattern, and somewhat more gain than parasitic elements, but large physical size limits it to use above 420 MHz. An interesting space-saving possibility lies in using a single plane reflector with elements for two different bands mounted on opposite sides. Reflector spacing from the driven element is not critical. About  $0.2 \lambda$  is common.

### THE CORNER REFLECTOR

When a single driven element is used, the reflector screen may be bent to form an angle, giving an improvement in the radiation pattern and gain. At 222 and 420 MHz its size assumes practical proportions, and at 902 MHz and higher, practical reflectors can approach ideal dimensions (very large in terms of wavelengths), resulting in more gain and sharper patterns. The corner reflector can be used at 144 MHz, though usually at much less than optimum size. For a given aperture, the corner reflector does not equal a parabola in gain, but it is simple to construct, broadbanded, and offers gains from about 10 to 15 dB, depending on the angle and size. This section was written by Paul M. Wilson, W4HHK.

The corner angle can be 90, 60 or  $45^\circ$ , but the side



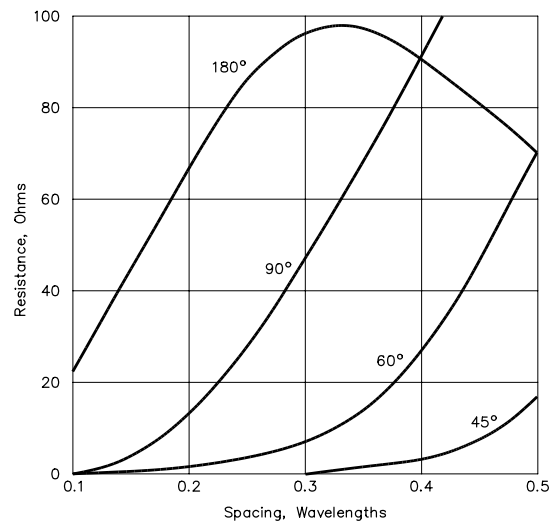
**Fig 10—Large collinear arrays should be fed as sets of no more than eight driven elements each, interconnected by phasing lines. This 48-element array for 432 MHz (A) is treated as if it were four 12-element collinear antennas. Reflector elements are omitted for clarity. The phasing harness is shown at B.**

length must be increased as the angle is narrowed. For a 90° corner, the driven element spacing can be anything from 0.25 to 0.7 λ, 0.35 to 0.75 λ for 60°, and 0.5 to 0.8 λ for 45°. In each case the gain variation over the range of spacings given is about 1.5 dB. Because the spacing is not very critical to gain, it may be varied for impedance matching purposes. Closer spacings yield lower feed-point impedances, but a folded dipole radiator could be used to raise this to a more convenient level.

Radiation resistance is shown as a function of spacing in Fig 11. The maximum gain obtained with minimum spacing is the primary mode (the one generally used at 144, 222 and 432 MHz to maintain reasonable side lengths). A 90° corner, for example, should have a minimum side length (S, Fig 12) equal to twice the dipole spacing, or 1 λ long for 0.5-λ spacing. A side length greater than 2 λ is ideal. Gain with a 60° or 90° corner reflector with 1 λ sides is about 10 dB. A 60° corner with 2 λ sides has about 12 dB gain, and a 45° corner with 3 λ sides has about 13 dB gain.

Reflector length (L, Fig 12) should be a minimum of 0.6 λ. Less than that spacing causes radiation to increase to the sides and rear, and decreases gain.

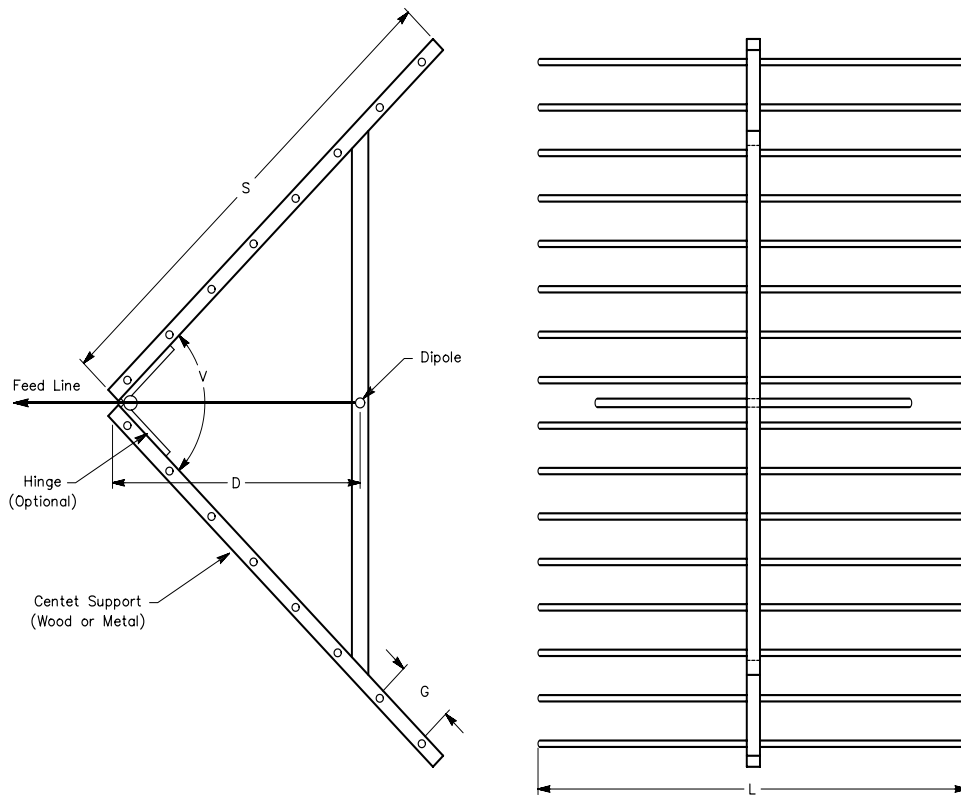
Spacing between reflector rods (G, Fig 12) should not exceed 0.06 λ for best results. A spacing of 0.06 λ results in a rear lobe that is about 6% of the forward lobe (down 12 dB). A small mesh screen or solid sheet is preferable at the higher frequencies to obtain maximum efficiency and highest F/B ratio, and to simplify construction. A spacing of 0.06 λ at 1296 MHz, for example, requires mounting reflector rods about every 1/2-inch along the sides. Rods or spines may be used to reduce wind loading. The support used for



**Fig 11—Radiation resistance of the driven element in a corner reflector array for corner angles of 180° (flat sheet), 90°, 60° and 45° as a function of spacing D, as shown in Fig 12.**

mounting the reflector rods may be of insulating or conductive material. Rods or mesh weave should be parallel to the radiator.

A suggested arrangement for a corner reflector is shown in Fig 12. The frame may be made of wood or metal, with a hinge at the corner to facilitate portable work or assembly atop a tower. A hinged corner is also useful in experimenting



**Fig 12—Construction of a corner reflector array. The frame can be wood or metal. Reflector elements are stiff wire or tubing. Dimensions for several bands are given in Table 2. Reflector element spacing, G, is the maximum that should be used for the frequency; closer spacings are optional. The hinge permits folding for portable use.**

with different angles. Table 2 gives the principal dimensions for corner reflector arrays for 144 to 2300 MHz. The arrays for 144, 222 and 420 MHz have side lengths of twice to four times the driven element spacing. The 915-MHz corner reflectors use side lengths of three times the element spacing, 1296-MHz corners use side lengths of four times the spacing, and 2304-MHz corners employ side lengths of six times the spacing. Reflector lengths of 2, 3, and 4 wavelengths are used on the 915, 1296 and 2304-MHz reflectors, respectively. A  $4 \times 6\text{-}\lambda$  reflector closely approximates a sheet of infinite dimensions.

A corner reflector may be used for several bands, or for UHF television reception, as well as amateur UHF work. For operation on more than one frequency, side length and reflector length should be selected for the lowest frequency, and reflector spacing for the highest frequency. The type of driven element plays a part in determining bandwidth, as does the spacing to the corner. A fat cylindrical element (small  $\lambda/\text{dia}$  ratio) or triangular dipole (bow tie) gives more bandwidth than a thin driven element. Wider spacings between driven element and corner give greater bandwidths. A small increase in gain can be obtained for any corner reflector by mounting collinear elements in a reflector of

sufficient size, but the simple feed of a dipole is lost if more than two elements are used.

A dipole radiator is usually employed with a corner reflector. This requires a balun between the coaxial line and the balanced feed-point impedance of the antenna. Baluns are easily constructed of coaxial line on the lower VHF bands, but become more difficult at the higher frequencies. This problem may be overcome by using a ground-plane corner reflector, which can be used for vertical polarization. A ground-plane corner with monopole driven element is shown in Fig 13. The corner reflector and a  $1/4\text{-}\lambda$  radiator are mounted on the ground plane, permitting direct connection to a coaxial line if the proper spacing is used. The effective aperture is reduced, but at the higher frequencies, second or third-mode radiator spacing and larger reflectors can be employed to obtain more gain and offset the loss in effective aperture. A J antenna could be used to maintain the aperture area and provide a match to a coaxial line.

For vertical polarization work, four  $90^\circ$  corner reflectors built back-to-back (with common reflectors) could be used for scanning  $360^\circ$  of horizon with modest gain. Feed-line switching could be used to select the desired sector.

**Table 2**

**Dimensions of Corner Reflector Arrays for VHF and UHF**

Freq, MHz	Side Length S, in.	Dipole to Vertex Distance D, in.	Reflector Length L, in.	Reflector Spacing G, in.	Corner Angle, V°	Radiation Resistance, Ω
144*	65	27 <sup>1</sup> / <sub>2</sub>	48	7 <sup>3</sup> / <sub>4</sub>	90	70
144	80	40	48	4	90	150
222*	42	18	30	5	90	70
222	52	25	30	3	90	150
222	100	25	30	Screen	60	70
420	27	8 <sup>3</sup> / <sub>4</sub>	16 <sup>1</sup> / <sub>4</sub>	2 <sup>5</sup> / <sub>8</sub>	90	70
420	54	13 <sup>1</sup> / <sub>2</sub>	16 <sup>1</sup> / <sub>4</sub>	Screen	60	70
915	20	6 <sup>1</sup> / <sub>2</sub>	25 <sup>3</sup> / <sub>4</sub>	0.65	90	70
915	51	16 <sup>3</sup> / <sub>4</sub>	25 <sup>3</sup> / <sub>4</sub>	Screen	60	65
915	78	25 <sup>3</sup> / <sub>4</sub>	25 <sup>3</sup> / <sub>4</sub>	Screen	45	70
1296	18	4 <sup>1</sup> / <sub>2</sub>	27 <sup>1</sup> / <sub>2</sub>	1/2	90	70
1296	48	11 <sup>3</sup> / <sub>4</sub>	27 <sup>1</sup> / <sub>2</sub>	Screen	60	65
1296	72	18 <sup>1</sup> / <sub>4</sub>	27 <sup>1</sup> / <sub>2</sub>	Screen	45	70
2304	15 <sup>1</sup> / <sub>2</sub>	2 <sup>1</sup> / <sub>2</sub>	20 <sup>1</sup> / <sub>2</sub>	1/4	90	70
2304	40	6 <sup>3</sup> / <sub>4</sub>	20 <sup>1</sup> / <sub>2</sub>	Screen	60	65
2304	61	10 <sup>1</sup> / <sub>4</sub>	20 <sup>1</sup> / <sub>2</sub>	Screen	45	70

**Notes:**

**915 MHz**

Wavelength is 12.9 in.

Side length S is 3 × D, dipole to vertex distance

Reflector length L is 2.0 λ

Reflector spacing G is 0.05 λ

**1296 MHz**

Wavelength is 9.11 in.

Side length S is 4 × D, dipole to vertex distance

Reflector length L is 3.0 λ

Reflector spacing G is 0.05 λ

**2304 MHz**

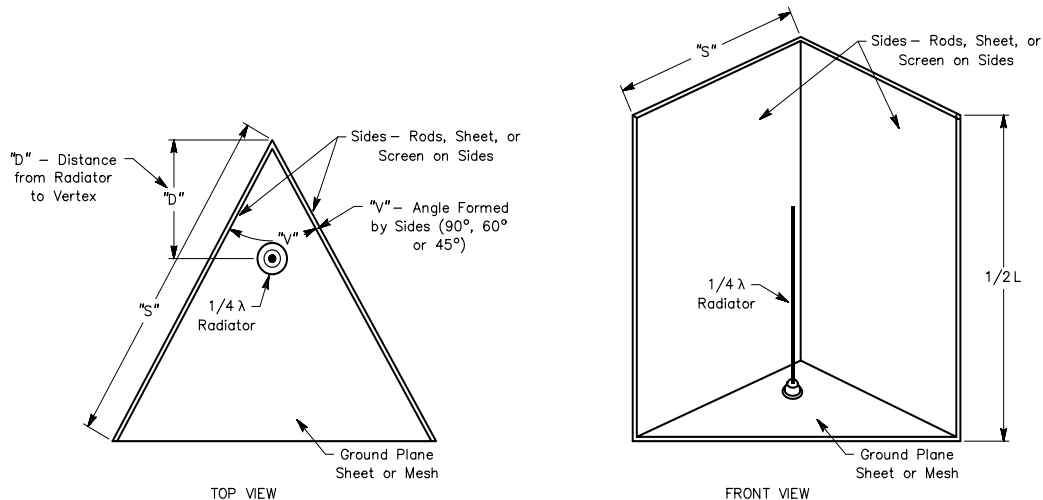
Wavelength is 5.12 in.

Side length S is 6 × D, dipole to vertex distance

Reflector length L is 4.0 λ

Reflector spacing G is 0.05 λ

\*Side length and number of reflector elements somewhat below optimum—slight reduction in gain.



**Fig 13—A ground-plane corner reflector antenna for vertical polarization, such as FM communications or packet radio. The dimension 1/2 L in the front view refers to data in Table 2.**

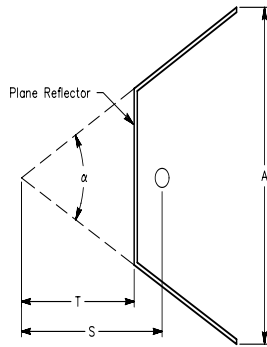
**TROUGH REFLECTORS**

To reduce the overall dimensions of a large corner reflector the vertex can be cut off and replaced with a plane reflector. Such an arrangement is known as a *trough reflector*. See Fig 14. Performance similar to that of the large corner reflector can thereby be had, provided that the dimensions of S and T as shown in Fig 14 do not exceed the limits indicated in the figure. This antenna provides performance very similar to the corner reflector, and presents

fewer mechanical problems because the plane center portion is relatively easy to mount on the mast. The sides are considerably shorter, as well.

The gain of both corner reflectors and trough reflectors may be increased by stacking two or more and arranging them to radiate in phase, or alternatively by adding further collinear dipoles (fed in phase) within a wider reflector. Not more than two or three radiating units should be used, because the great virtue of the simple feeder arrangement would then be lost.





Angle $\alpha$	Value of S for maximum gain	Gain	Value of T
90°	1.5 $\lambda$	13 dB	1 $\lambda$ -1.25 $\lambda$
60°	1.75 $\lambda$	15 dB	1.0 $\lambda$
45°	2.0 $\lambda$	17 dB	1.9 $\lambda$

**Fig 14—The trough reflector.** This is a useful modification of the corner reflector. The vertex has been cut off and replaced by a simple plane section. The tabulated data shows the gain obtainable for greater values of S than those covered in Table 2, assuming that the reflector is of adequate size.

### HORN ANTENNAS FOR THE MICROWAVE BANDS

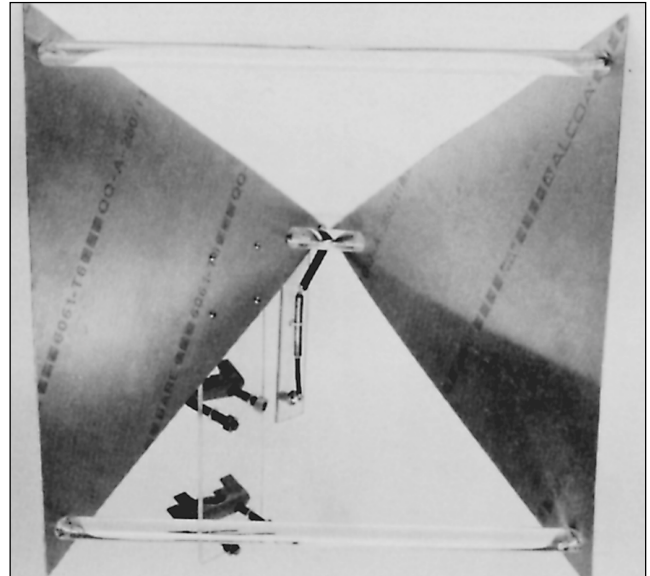
Horn antennas were briefly introduced in the section on coupling energy into and out of waveguides. For amateur purposes, horns begin to show usable gain with practical dimensions in the 902-MHz band.

It isn't necessary to feed a horn with waveguide. If only two sides of a pyramidal horn are constructed, the antenna may be fed at the apex with a two-conductor transmission line. The impedance of this arrangement is on the order of 300 to 400  $\Omega$ . A 60° two-sided pyramidal horn with 18-inch sides is shown in Fig 15. This antenna has a theoretical gain of 15 dBi at 1296 MHz, although the feed system detailed in Fig 16 probably degrades this value somewhat. A  $\frac{1}{4} \lambda$ , 150- $\Omega$  matching section made from two parallel lengths of twin-lead connects to a bazooka balun made from RG-58 cable and a brass tube. This matching system was assembled strictly for the purpose of demonstrating the two-sided horn in a 50- $\Omega$  system. In a practical installation the horn would be fed with open wire line and matched to 50  $\Omega$  at the station equipment.

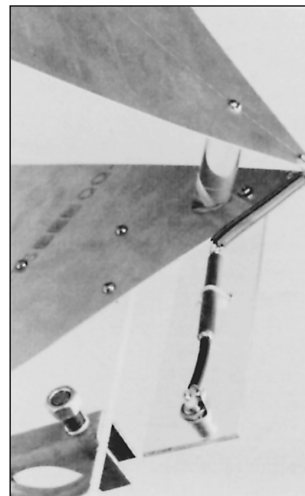
### PARABOLIC ANTENNAS

When an antenna is located at the focus of a parabolic reflector (dish), it is possible to obtain considerable gain. Furthermore, the beamwidth of the radiated energy will be very narrow, provided all the energy from the driven element is directed toward the reflector. This section was written by Paul M. Wilson, W4HHK.

Gain is a function of parabolic reflector diameter, surface accuracy and proper illumination of the reflector by



**Fig 15—An experimental two-sided pyramidal horn** constructed in the ARRL laboratory. A pair of muffer clamps allows mounting the antenna on a mast. This model has sheet-aluminum sides, although window screen would work as well. Temporary elements could be made from cardboard covered with aluminum foil. The horizontal spreaders are Plexiglas rod. Oriented as shown here, the antenna radiates horizontally polarized waves.



**Fig 16—Matching system used to test the horn.** Better performance would be realized with open wire line. See text.

the feed. Gain may be found from

$$G = 10 \log k \left( \frac{\pi D}{\lambda} \right)^2 \quad (\text{Eq 1})$$

where

G = gain over an isotropic antenna, dB (subtract 2.15 dB for gain over a dipole)

k = efficiency factor, usually about 55%

D = dish diameter in feet

$\lambda$  = wavelength in feet

See Table 3 for parabolic antenna gain for the bands 420 MHz through 10 GHz and diameters of 2 to 30 feet.

**Table 3**  
**Gain, Parabolic Antennas\***

Frequency	Dish Diameter (Feet)						
	2	4	6	10	15	20	30
420 MHz	6.0	12.0	15.5	20.0	23.5	26.0	29.5
902	12.5	18.5	22.0	26.5	30.0	32.5	36.0
1215	15.0	21.0	24.5	29.0	32.5	35.0	38.5
2300	20.5	26.5	30.0	34.5	38.0	40.5	44.0
3300	24.0	30.0	33.5	37.5	41.5	43.5	47.5
5650	28.5	34.5	38.0	42.5	46.0	48.5	52.0
10 GHz	33.5	39.5	43.0	47.5	51.0	53.5	57.0

\*Gain over an isotropic antenna (subtract 2.1 dB for gain over a dipole antenna). Reflector efficiency of 55% assumed.

A close approximation of beamwidth may be found from

$$\psi = \frac{70\lambda}{D} \quad (\text{Eq 2})$$

where

- $\psi$  = beamwidth in degrees at half-power points (3 dB down)
- D = dish diameter in feet
- $\lambda$  = wavelength in feet

At 420 MHz and higher, the parabolic dish becomes a practical antenna. A simple, single feed point eliminates phasing harnesses and balun requirements. Gain is dependent on good surface accuracy, which is more difficult to achieve with increasing frequency. Surface errors should not exceed  $1/8 \lambda$  in amateur work. At 430 MHz  $1/8 \lambda$  is 3.4 inches, but at 10 GHz it is 0.1476 inch! Mesh can be used for the reflector surface to reduce weight and wind loading, but hole size should be less than  $1/12 \lambda$ . At 430 MHz the use of 2-inch hole diameter poultry netting (chicken wire) is acceptable. Fine mesh aluminum screening works well as high as 10 GHz.

A support form may be fashioned to provide the proper parabolic shape by plotting a curve (Fig 17) from

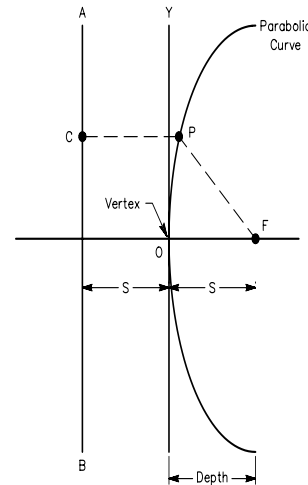
$$Y^2 = 4SX$$

as shown in the figure.

Optimum illumination occurs when power at the reflector edge is 10 dB less than that at the center. A circular waveguide feed of correct diameter and length for the frequency and correct beamwidth for the dish focal length to diameter ( $f/D$ ) ratio provides optimum illumination at 902 MHz and higher. This, however, is impractical at 432 MHz, where a dipole and plane reflector are often used. An  $f/D$  ratio between 0.4 and 0.6 is considered ideal for maximum gain and simple feeds.

The focal length of a dish may be found from

$$f = \frac{D}{16d} \quad (\text{Eq 3})$$



**Fig 17—Details of the parabolic curve,  $Y^2 = 4SX$ . This curve is the locus of points which are equidistant from a fixed point, the focus (F), and a fixed line (AB) which is called the *directrix*. Hence,  $FP = PC$ . The focus (F) is located at coordinates  $S,0$ .**

where

- f = focal length
- D = diameter
- d = depth distance from plane at mouth of dish to vertex (see Fig 17)

The units of focal length f are the same as those used to measure the depth and diameter.

Table 4 gives the subtended angle at focus for dish  $f/D$  ratios from 0.2 to 1.0. A dish, for example, with a typical  $f/D$  of 0.4 requires a 10-dB beamwidth of  $130^\circ$ . A circular waveguide feed with a diameter of approximately  $0.7 \lambda$  provides nearly optimum illumination, but does not uniformly illuminate the reflector in both the magnetic (TM) and electric (TE) planes. Fig 18 shows data for plotting radiation patterns from circular guides. The waveguide feed aperture can be modified to change the beamwidth.

One approach used successfully by some experimenters is the use of a disc at a short distance behind the aperture as shown in Fig 19. As the distance between the aperture and disc is changed, the TM plane patterns become alternately broader and narrower than with an unmodified aperture. A disc about  $2 \lambda$  in diameter appears to be as effective as a much larger one. Some experimenters have noted a 1 to 2 dB increase in dish gain with this modified feed. Rectangular waveguide feeds can also be used, but dish illumination is not as uniform as with round guide feeds.

The circular feed can be made of copper, brass, aluminum or even tin in the form of a coffee or juice can, but the latter must be painted on the outside to prevent rust or corrosion. The circular feed must be within a proper size (diameter) range for the frequency being used. This feed operates in the dominant circular waveguide mode known

**Table 4**  
**f/D Versus Subtended Angle at Focus of a Parabolic Reflector Antenna**

f/D	Subtended Angle (Deg.)	f/D	Subtended Angle (Deg.)
0.20	203	0.65	80
0.25	181	0.70	75
0.30	161	0.75	69
0.35	145	0.80	64
0.40	130	0.85	60
0.45	117	0.90	57
0.50	106	0.95	55
0.55	97	1.00	52
0.60	88		

Taken from graph "f/D vs Subtended Angle at Focus," page 170 of the 1966 *Microwave Engineers' Handbook and Buyers Guide*. Graph courtesy of K. S. Kelleher, Aero Geo Astro Corp, Alexandria, Virginia.

as the TE<sub>11</sub> mode. The guide must be large enough to pass the TE<sub>11</sub> mode with no attenuation, but smaller than the diameter that permits the next higher TM<sub>01</sub> mode to propagate. To support the desirable TE<sub>11</sub> mode in circular waveguide, the cutoff frequency, F<sub>C</sub>, is given by

$$F_C (TE_{11}) = \frac{6917.26}{d(\text{inches})} \quad (\text{Eq 4})$$

where

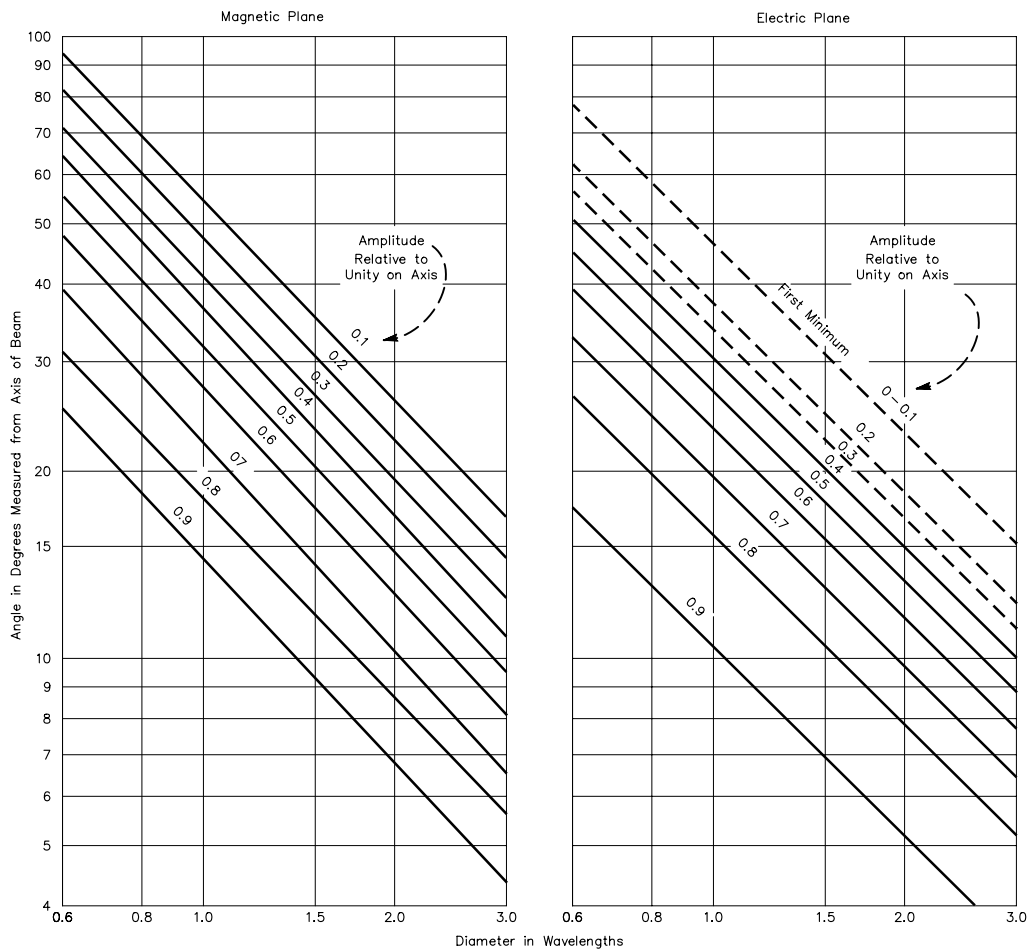
f<sub>C</sub> = cutoff frequency in MHz for TE<sub>11</sub> mode

d = waveguide inner diameter

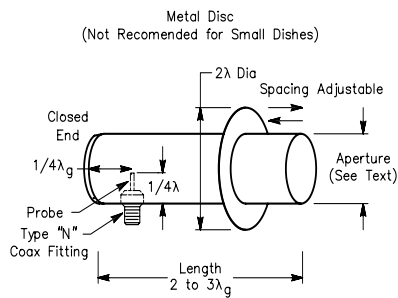
A circular waveguide will support the TM<sub>01</sub> mode having a cutoff frequency

$$F_C (TM_{01}) = \frac{9034.85}{d(\text{inches})} \quad (\text{Eq 5})$$

The wavelength in a waveguide always exceeds the free-space wavelength and is called guide wavelength, λ<sub>g</sub>. It is



**Fig 18—This graph can be used in conjunction with Table 4 for selecting the proper diameter waveguide to illuminate a parabolic reflector.**



**Fig 19—Details of a circular waveguide feed.**

related to the cutoff frequency and operating frequency by the equation

$$\lambda_g = \frac{11802.85}{\sqrt{f_0^2 - f_C^2}} \quad (\text{Eq 6})$$

where

- $\lambda_g$  = guide wavelength, inches
- $f_0$  = operating frequency, MHz
- $f_C$  = TE<sub>11</sub> waveguide cutoff frequency, MHz

An inside diameter range of about 0.66 to 0.76  $\lambda$  is suggested. The lower frequency limit (longer dimension) is dictated by proximity to the cutoff frequency. The higher frequency limit (shorter dimension) is dictated by higher order waves. See **Table 5** for recommended inside diameter dimensions for the 902 to 10,000-MHz amateur bands.

The probe that excites the waveguide and makes the transition from coaxial cable to waveguide is  $1/4 \lambda$  long and spaced from the closed end of the guide by  $1/4$  guide wavelength. The length of the feed should be two to three guide wavelengths. The latter is preferred if a second probe is to be mounted for polarization change or for polaplexer work where duplex communication (simultaneous transmission and reception) is possible because of the isolation between two properly located and oriented probes. The second probe for polarization switching or polaplexer work should be spaced  $3/4$  guide wavelength from the closed end and mounted at right angles to the first probe.

The feed aperture is located at the focal point of the dish and aimed at the center of the reflector. The feed mounts should permit adjustment of the aperture either side of the focal point and should present a minimum of blockage to the reflector. Correct distance to the dish center places the focal point about 1 inch inside the feed aperture. The use of a nonmetallic support minimizes blockage. PVC pipe, fiberglass and Plexiglas are commonly used materials. A simple test by placing a material in a microwave oven reveals if it is satisfactory up to 2450 MHz. PVC pipe has tested satisfactorily and appears to work well at 2300 MHz. A simple, clean looking mount for a 4-foot dish with 18 inches focal length, for example, can be made by mounting a length

**Table 5  
Circular Waveguide Dish Feeds**

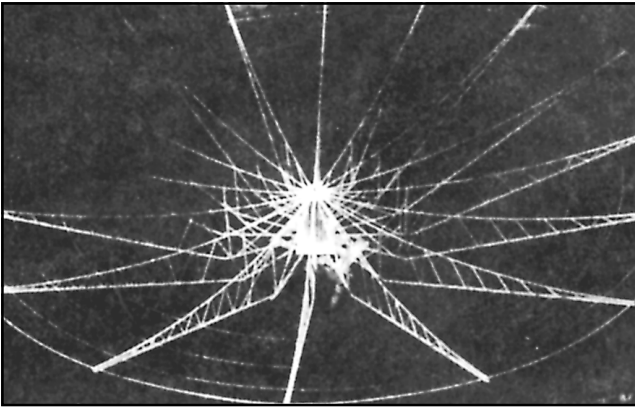
Freq (MHz)	Inside Diameter Circular Waveguide Range (in.)
915	8.52-9.84
1296	6.02-6.94
2304	3.39-3.91
3400	2.29-2.65
5800	1.34-1.55
10,250	0.76-0.88

of 4-inch PVC pipe using a PVC flange at the center of the dish. At 2304 MHz the circular feed is approximately 4 inches ID, making a snug fit with the PVC pipe. Precautions should be taken to keep rain and small birds from entering the feed.

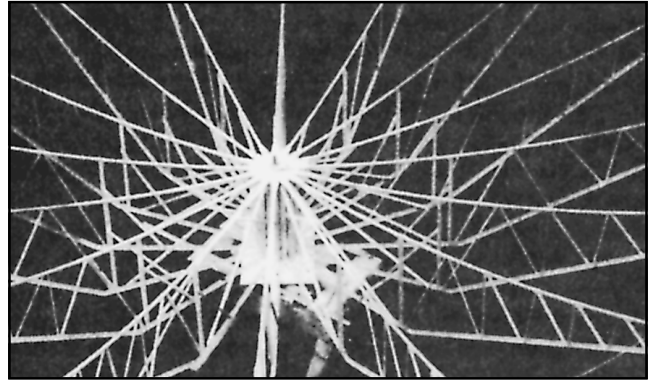
*Never look into the open end of a waveguide when power is applied, or stand directly in front of a dish while transmitting.* Tests and adjustments in these areas should be done while receiving or at extremely low levels of transmitter power (less than 0.1 W). The US Government has set a limit of 10 mW/cm<sup>2</sup> averaged over a 6-minute period as the safe maximum. Other authorities believe even lower levels should be used. Destructive thermal heating of body tissue results from excessive exposure. This heating effect is especially dangerous to the eyes. The accepted safe level of 10 mW/cm<sup>2</sup> is reached in the near field of a parabolic antenna if the level at  $2D^2/\lambda$  is 0.242 mW/cm<sup>2</sup>. The equation for power density is



**Fig 20—Coffee-can 2304-MHz feed described in text and Fig 19 mounted on a 4-foot dish.**



**Fig 21—Aluminum framework for a 23-foot dish under construction by ZL1BJQ.**



**Fig 22—Detailed look at the hub assembly for the ZL1BJQ dish. Most of the structural members are made from 3/4-inch T section.**

$$\text{Power density} = \frac{3\lambda P}{64D^2} = \frac{158.4P}{D^2} \text{ mW/cm}^2 \quad (\text{Eq 7})$$

where

P = average power in kilowatts

D = antenna diameter in feet

$\lambda$  = wavelength in feet

New commercial dishes are expensive, but surplus ones can often be purchased at low cost. Some amateurs build theirs, while others modify UHF TV dishes or circular metal snow sleds for the amateur bands. **Fig 20** shows a dish using the homemade feed just described. Photos showing a highly ambitious dish project built by ZL1BJQ appear in **Figs 21**

and **22**. Practical details for constructing this type of antenna are given in **Chapter 19**. **Dick Knadle, K2RIW**, described modern UHF antenna test procedures in February 1976 *QST* (see Bibliography).

### OMNIDIRECTIONAL ANTENNAS FOR VHF AND UHF

Local work with mobile stations requires an antenna with wide coverage capabilities. Most mobile work is on FM, and the polarization used with this mode is generally vertical. Some simple vertical systems are described below. Additional material on antennas of this type is presented in **Chapter 16**.

## Ground-plane Antennas for 144, 222 and 440 MHz

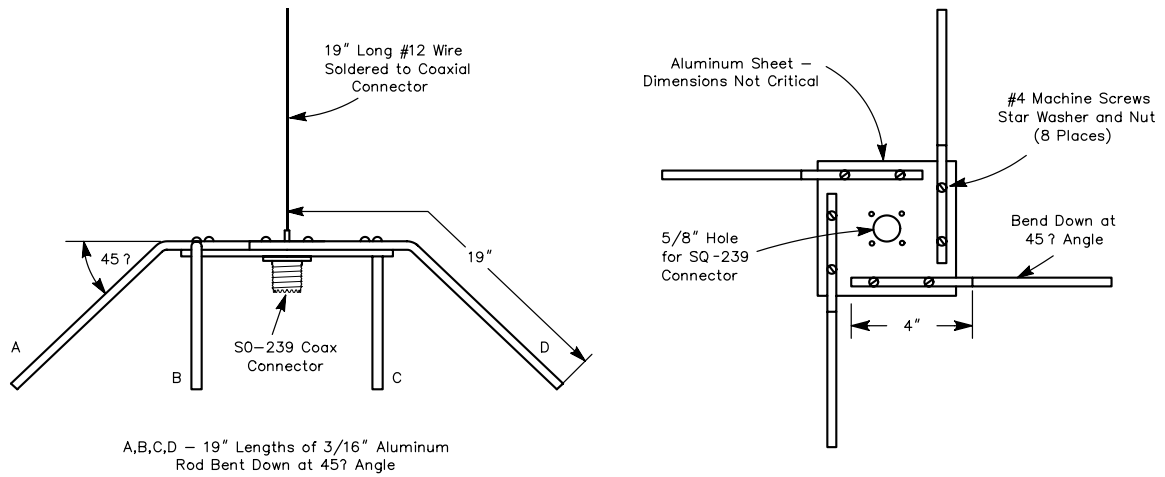
For the FM operator living in the primary coverage area of a repeater, the ease of construction and low cost of a  $\frac{1}{4}\lambda$  ground-plane antenna make it an ideal choice. Three different types of construction are detailed in **Figs 23, 24, 25** and **26**; the choice of construction method depends on the materials at hand and the desired style of antenna mounting.

The 144-MHz model shown in **Fig 23** uses a flat piece of sheet aluminum, to which radials are connected with machine screws. A 45° bend is made in each of the radials. This bend can be made with an ordinary bench vise. An SO-239 chassis connector is mounted at the center of the aluminum plate with the threaded part of the connector facing down. The vertical portion of the antenna is made of #12 copper wire soldered directly to the center pin of the SO-239 connector.

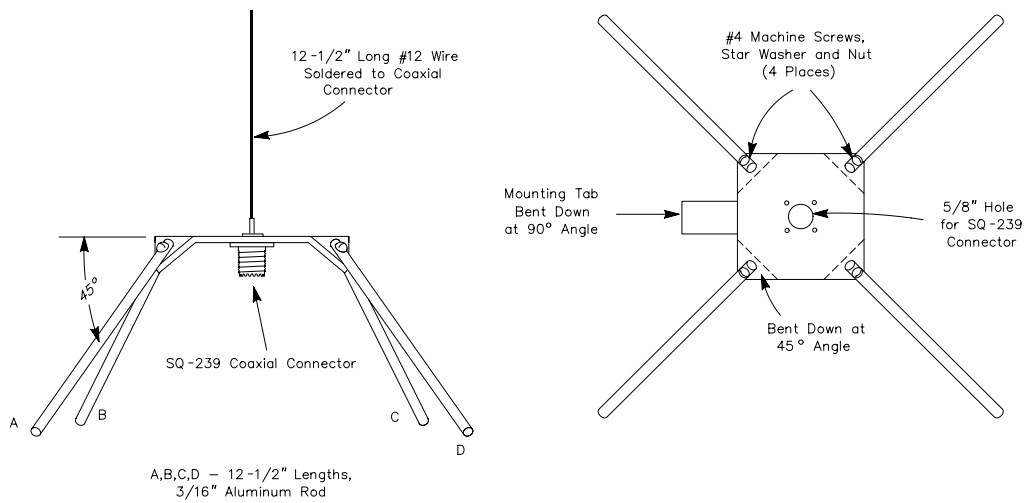
The 222-MHz version, **Fig 24**, uses a slightly different technique for mounting and sloping the radials. In this case

the corners of the aluminum plate are bent down at a 45° angle with respect to the remainder of the plate. The four radials are held to the plate with machine screws, lock washers and nuts. A mounting tab is included in the design of this antenna as part of the aluminum base. A compression type of hose clamp could be used to secure the antenna to a mast. As with the 144-MHz version, the vertical portion of the antenna is soldered directly to the SO-239 connector.

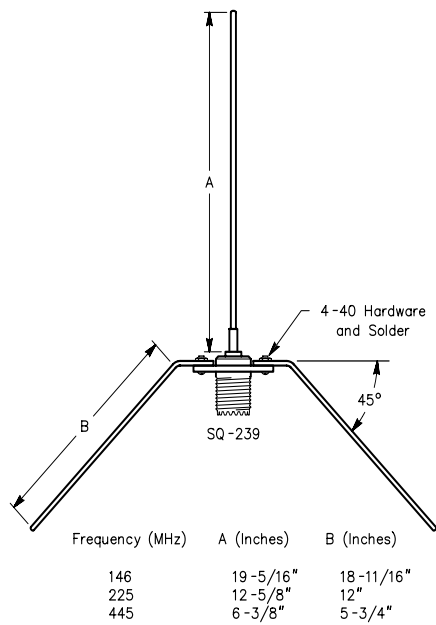
A very simple method of construction, shown in **Figs 25** and **26**, requires nothing more than an SO-239 connector and some #4-40 hardware. A small loop formed at the inside end of each radial is used to attach the radial directly to the mounting holes of the coaxial connector. After the radial is fastened to the SO-239 with #4-40 hardware, a large soldering iron or propane torch is used to solder the radial and the mounting hardware to the coaxial connector. The radials are bent to a 45° angle and the vertical portion is soldered to the center pin to complete the antenna. The antenna can be



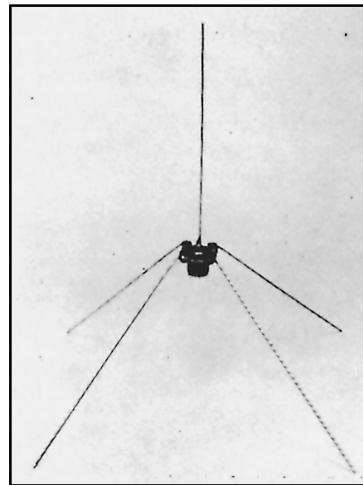
**Fig 23**—These drawings illustrate the dimensions for the 144-MHz ground-plane antenna.



**Fig 24**—Dimensional information for the 222-MHz ground-plane antenna. Lengths for A, B, C and D are the total distances measured from the center of the SQ-239 connector. The corners of the aluminum plate are bent down at a 45° angle rather than bending the aluminum rod as in the 144-MHz model. Either method is suitable for these antennas.



**Fig 25—Simple ground-plane antenna for the 144, 222 and 440-MHz bands. The vertical element and radials are 3/32 or 1/16-inch brass welding rod. Although 3/32-inch rod is preferred for the 144-MHz antenna, #10 or #12 copper wire can also be used.**



**Fig 26—A 440-MHz ground-plane constructed using only an SO-239 connector, #4-40 hardware and 1/16-inch brass welding rod.**

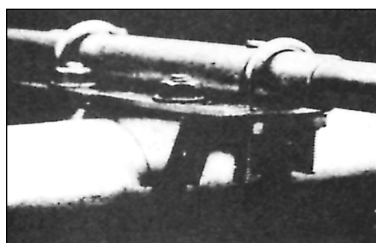
mounted by passing the feed line through a mast of 3/4-inch ID plastic or aluminum tubing. A compression hose clamp can be used to secure the PL-259 connector, attached to the feed line, in the end of the mast. Dimensions for the 144, 222 and 440-MHz bands are given in Fig 25.

If these antennas are to be mounted outside it is wise to apply a small amount of RTV sealant or similar material around the areas of the center pin of the connector to prevent the entry of water into the connector and coax line.

## Practical 6-Meter Yagis

Boom length often proves to be the deciding factor when one selects a Yagi design. **Table 6** shows three 6-meter Yagis designed for convenient boom lengths (6, 12 and 22 feet). The 3-element, 6-foot boom design has 8 dBi gain in free space; the 12-foot boom, 5-element version has 10 dBi gain, and the 22-foot, 7-element Yagi has a gain of 11.4 dBi. All antennas exhibit better than 22 dB front-to-rear ratio and cover 50 to 51 MHz with better than 1.6:1 SWR.

Element half lengths and spacings are given in the table. Elements can be mounted to the boom as shown in **Fig 27**. Two muffler clamps hold each aluminum plate to the boom, and two U bolts fasten each element to the plate, which is 0.25 inches thick and 4 x 4 inches square. Stainless steel is the best choice for hardware; however, galvanized hardware can be substituted. Automotive muffler clamps do not work well in this application, because they are not galvanized and

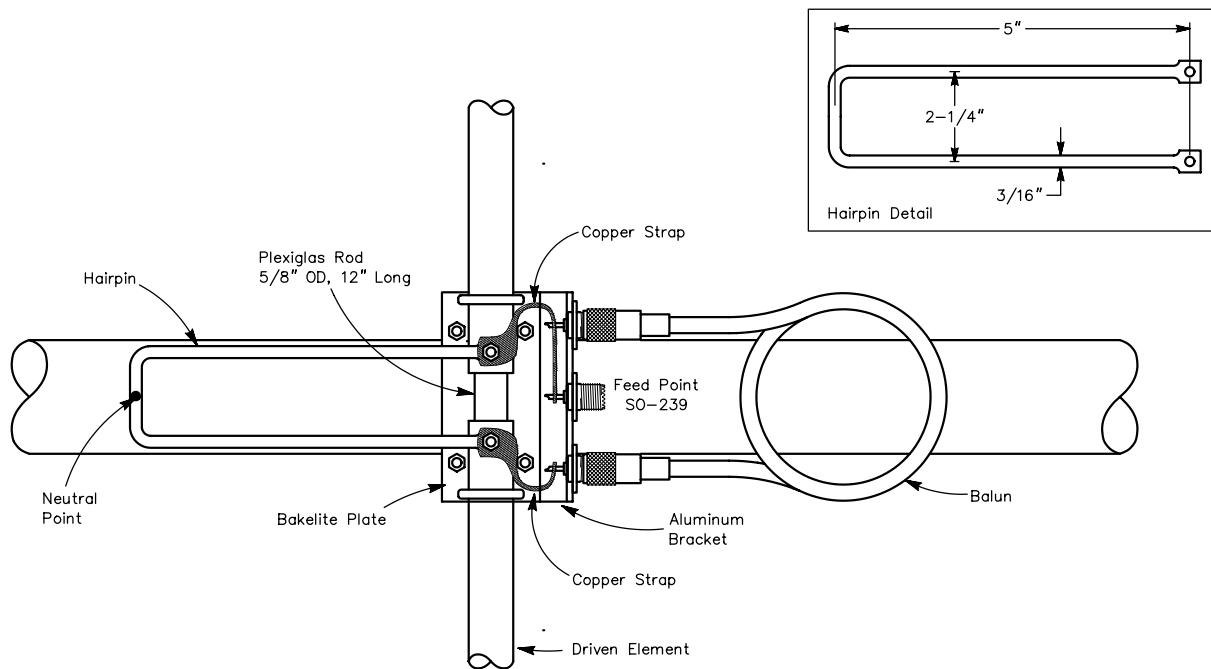


**Fig 27—The element to boom clamp. U bolts are used to hold the element to the plate, and 2-inch galvanized muffer clamps hold the plates to the boom.**

**Table 6  
Optimized 6-Meter Yagi Designs**

	Spacing Between Elements inches	Seg 1 OD* Length inches	Seg 2 OD* Length inches	Midband Gain F/R
<b>306-06</b>				
OD		0.750	0.625	
Refl.	0	36	22.500	8.1 dBi
D.E.	24	36	16.000	28.3 dB
Dir. 1	42	36	15.500	
<b>506-12</b>				
OD		0.750	0.625	
Refl.	0	36	23.625	10.0 dBi
D.E.	24	36	17.125	26.8 dB
Dir. 1	12	36	19.375	
Dir. 2	44	36	18.250	
Dir. 3	58	36	15.375	
<b>706-22</b>				
OD		0.750	0.625	
Refl.	0	36	24.750	11.4 dBi
D.E.	27	36	15.625	24.3 dB
Dir. 1	16	36	17.250	
Dir. 2	51	36	15.250	
Dir. 3	54	36	15.500	
Dir. 4	53	36	15.750	
Dir. 5	58	36	12.750	

\* See pages 20-6 to 20-10 for telescoping aluminum tubing details.



**Fig 28**—This shows how the driven element and feed system are attached to the boom. The phasing line is coiled and taped to the boom. The center of the hairpin loop may be connected to the boom electrically and mechanically if desired.

**Phasing-line lengths:**

**For cable with 0.80 velocity factor—7 feet, 10<sup>3</sup>/<sub>8</sub> inches**

**For cable with 0.66 velocity factor—6 feet, 5<sup>3</sup>/<sub>4</sub> inches**

quickly rust once exposed to the weather.

The driven element is mounted to the boom on a Bakelite or G-10 fiberglass plate of similar dimension to the other mounting plates. A 12-inch piece of Plexiglas rod is inserted into the driven element halves. The Plexiglas allows the use of a single clamp on each side of the element and also seals the center of the elements against moisture. Self-tapping screws are used for electrical connection to the driven element.

Refer to **Fig 28** for driven element and hairpin match details. A bracket made from a piece of aluminum is used to mount the three SO-239 connectors to the driven element plate. A 4:1 transmission-line balun connects the two element halves, transforming the 200-Ω resistance at the hairpin match to 50 Ω at the center connector. Note that the electrical length of the balun is  $\lambda/2$ , but the physical length will be

shorter due to the velocity factor of the particular coaxial cable used. The hairpin is connected directly across the element halves. The exact center of the hairpin is electrically neutral and should be fastened to the boom. This has the advantage of placing the driven element at dc ground potential.

The hairpin match requires no adjustment as such. However, you may have to change the length of the driven element slightly to obtain the best match in your preferred portion of the band. Changing the driven-element length will not adversely affect antenna performance. *Do not adjust the lengths or spacings of the other elements—they are optimized already.* If you decide to use a gamma match, add 3 inches to each side of the driven element lengths given in the table for all antennas.



# High-Performance Yagis for 144, 222 and 432 MHz

This construction information is presented as an introduction to the three high-performance VHF/UHF Yagis that follow. All were designed and built by Steve Powlshen, K1FO.

For years the design of long Yagi antennas seemed to be a mystical black art. The problem of simultaneously optimizing 20 or more element spacings and element lengths presented an almost unsolvable set of simultaneous equations. With the unprecedented increase in computer power and widespread availability of antenna analysis software, we are now able to quickly examine many Yagi designs and determine which approaches work and which designs to avoid.

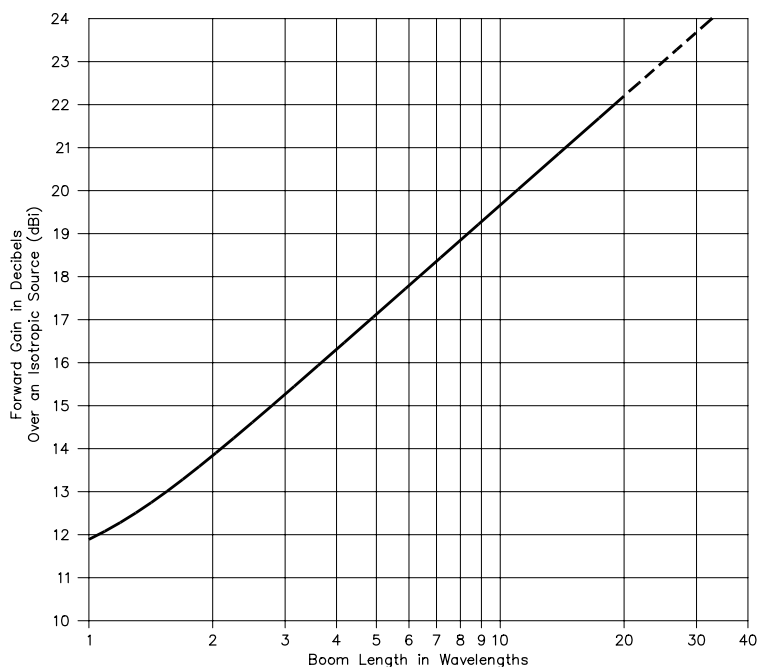
At 144 MHz and above, most operators desire Yagi antennas two or more wavelengths in length. This length ( $2\lambda$ ) is where most classical designs start to fall apart in terms of gain per boom length, bandwidth and pattern quality. Extensive computer and antenna range analysis has proven that the best possible design is a Yagi that has both varying element spacings and varying element lengths.

This design approach starts with closely spaced directors. The director spacings gradually increase until a constant spacing of about  $0.4\lambda$  is reached. Conversely, the director lengths start out longest with the first director and decrease in length in a decreasing rate of change until they are virtually constant in length. This method of construction results in a wide gain bandwidth. A bandwidth of 7% of the center frequency at the  $-1$  dB forward-gain points is typical

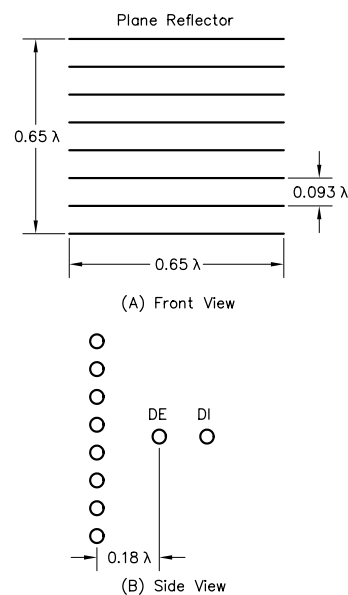
for these Yagis even when they are longer than  $10\lambda$ . The log-taper design also reduces the rate of change in driven-element impedance vs frequency. This allows the use of simple dipole driven elements while still obtaining acceptable driven-element SWR over a wide frequency range. Another benefit is that the resonant frequency of the Yagi changes very little as the boom length is increased. The driven-element impedance also changes moderately with boom length. The tapered approach creates a Yagi with a very clean radiation pattern. Typically, first side lobe levels of  $-17$  dB in the E plane,  $-15$  dB in the H plane, and all other lobes at  $-20$  dB or more are possible on designs from  $2\lambda$  to more than  $14\lambda$ .

The actual rate of change in element lengths is determined by the diameter of the elements (in wavelengths). The spacings can be optimized for an individual boom length or chosen as a best compromise for most boom lengths.

The gain of long Yagis has been the subject of much debate. Recent measurements and computer analysis by both amateurs and professionals indicates that given an optimum design, doubling a Yagi's boom length will result in a maximum theoretical gain increase of about 2.6 dB. In practice, the real gain increase may be less because of escalating resistive losses and the greater possibility of construction error. **Fig 29** shows the maximum possible gain per boom length expressed in decibels, referenced to an isotropic radiator. The actual number of directors does not play an important part in determining the gain vs boom length



**Fig 29**—This chart shows maximum gain per boom length for optimally designed long Yagi antennas.



**Fig 30**—Front and side views of a plane-reflector antenna.

as long as a reasonable number of directors are used. The use of more directors per boom length will normally give a wider gain bandwidth, however, a point exists where too many directors will adversely affect all performance aspects.

While short antennas ( $< 1.5 \lambda$ ) may show increased gain with the use of quad or loop elements, long Yagis ( $> 2 \lambda$ ) will not exhibit measurably greater forward gain or pattern integrity with loop-type elements. Similarly, loops used as driven elements and reflectors will not significantly change the properties of a long log-taper Yagi. Multiple-dipole driven-element assemblies will also not result in any significant gain increase per given boom length when compared to single-dipole feeds.

Once a long-Yagi director string is properly tuned, the reflector becomes relatively noncritical. Reflector spacings between  $0.15 \lambda$  and  $0.2 \lambda$  are preferred. The spacing can be chosen for best pattern and driven element impedance. Multiple-reflector arrangements will not significantly increase the forward gain of a Yagi which has its directors properly optimized for forward gain. Many multiple-reflector schemes such as tri-reflectors and corner reflectors have the disadvantage of lowering the driven element impedance compared to a single optimum-length reflector. The plane or grid reflector, shown in [Fig 30](#), may however reduce the intensity of unwanted rear lobes. This can be used to reduce noise pickup on EME or satellite arrays. This type of reflector will usually increase the driven-element impedance compared to a single reflector. This sometimes makes driven-element matching easier. Keep in mind that even for EME, a plane reflector will add considerable wind load and weight for only a few tenths of a decibel of receive signal-to-noise improvement.

### Yagi Construction

Normally, aluminum tubing or rod is used for Yagi elements. Hard-drawn enamel-covered copper wire can also be used on Yagis above 420 MHz. Resistive losses are inversely proportional to the square of the element diameter and the square root of its conductivity.

Element diameters of less than  $3/16$  inch or 4 mm should not be used on any band. The size should be chosen for reasonable strength. Half-inch diameter is suitable for 50 MHz,  $3/16$  to  $3/8$  inch for 144 MHz and  $3/16$  inch is recommended for the higher bands. Steel, including stainless steel and unprotected brass or copper wire, should not be used for elements.

Boom material may be aluminum tubing, either square or round. High-strength aluminum alloys such as 6061-T6 or 6063-T651 offer the best strength-to-weight advantages. Fiberglass poles have been used (where available as surplus). Wood is a popular low-cost boom material. The wood should be well seasoned and free from knots. Clear pine, spruce and Douglas fir are often used. The wood should be well treated to avoid water absorption and warping.

Elements may be mounted insulated or uninsulated, above or through the boom. Mounting uninsulated elements

through a metal boom is the least desirable method unless the elements are welded in place. The Yagi elements will oscillate, even in moderate winds. Over several years this element oscillation will work open the boom holes. This will allow the elements to move in the boom. This will create noise (in your receiver) when the wind blows, as the element contact changes. Eventually the element-to-boom junction will corrode (aluminum oxide is a good insulator). This loss of electrical contact between the boom and element will reduce the boom's effect and change the resonant frequency of the Yagi.

Noninsulated elements mounted above the boom will perform fine as long as a good mechanical connection is made. Insulating blocks mounted above the boom will also work, but they require additional fabrication. One of the most popular construction methods is to mount the elements through the boom using insulating shoulder washers. This method is lightweight and durable. Its main disadvantage is difficult disassembly, making this method of limited use for portable arrays.

If a conductive boom is used, element lengths must be corrected for the mounting method used. The amount of correction is dependent on the boom diameter in wavelengths. See [Fig 31](#). Elements mounted through the boom and not insulated require the greatest correction. Mounting on top of the boom or through the boom on insulated shoulder washers requires about half of the through-the-boom correction. Insulated elements mounted at least one element diameter above the boom require no correction over the free-space length.

The three following antennas have been optimized for typical boom lengths on each band.

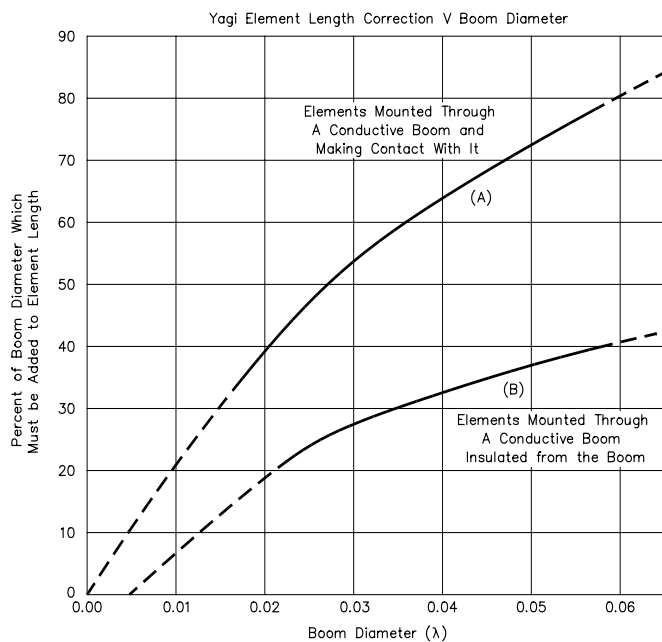
### A HIGH-PERFORMANCE 432-MHz YAGI

This 22-element,  $6.1\text{-}\lambda$ , 432-MHz Yagi was originally designed for use in a 12-Yagi EME array built by K1FO. A lengthy evaluation and development process preceded its construction. Many designs were considered and then analyzed on the computer. Next, test models were constructed and evaluated on a homemade antenna range. The resulting design is based on W1EJ's computer-optimized spacings.

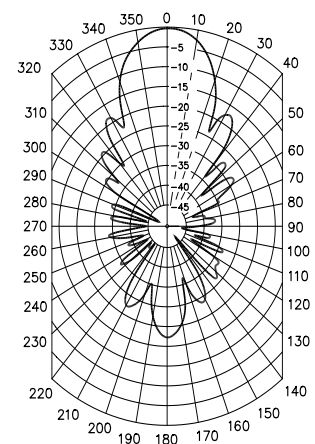
The attention paid to the design process has been worth the effort. The 22-element Yagi not only has exceptional forward gain (17.9 dBi), but has an unusually "clean" radiation pattern. The measured E-plane pattern is shown in [Fig 32](#). Note that a 1-dB-per-division axis is used to show pattern detail. A complete description of the design process and construction methods appears in December 1987 and January 1988 *QST*.

Like other log-taper Yagi designs, this one can easily be adapted to other boom lengths. Versions of this Yagi have been built by many amateurs. Boom lengths ranged between  $5.3 \lambda$  (20 elements) and  $12.2 \lambda$  (37 elements).

The size of the original Yagi (169 inches long,  $6.1 \lambda$ ) was chosen so the antenna could be built from small-diameter boom material ( $7/8$  inch and 1 inch round 6061-T6 aluminum)



**Fig 31—Yagi element correction vs boom diameter. Curve A is for elements mounted through a round or square conductive boom, with the elements in mechanical contact with the boom. Curve B is for insulated elements mounted through a conductive boom, and for elements mounted on top of a conductive boom (elements make electrical contact with the boom). The patterns were corrected to computer simulations to determine Yagi tuning. The amount of element correction is not affected by element diameter.**



**Fig 32—Measured E-plane pattern for the 22-element Yagi. Note: This antenna pattern is drawn on a linear dB grid, rather than on the standard ARRL log-periodic grid, to emphasize low sidelobes.**

and still survive high winds and ice loading. The 22-element Yagi weighs about 3.5 pounds and has a wind load of approximately 0.8 square feet. This allows a high-gain EME array to be built with manageable wind load and weight. This same low wind load and weight lets the tropo operator add a high-performance 432-MHz array to an existing tower without sacrificing antennas on other bands.

**Table 7** lists the gain and stacking specifications for the various length Yagis. The basic Yagi dimensions are shown in **Table 8**. These are free-space element lengths for  $3/16$ -inch-diameter elements. Boom corrections for the element mounting method must be added in. The element-length correction column gives the length that must be added to keep the Yagi's center frequency optimized for use at 432 MHz. This correction is required to use the same spacing pattern over a wide range of boom lengths. Although any length Yagi will work well, this design is at its best when made with 18 elements or more (4.6 l). Element material of less than  $3/16$ -inch diameter is not recommended because resistive losses will reduce the gain by about 0.1 dB, and wet-weather performance will be worse.

Quarter-inch-diameter elements could be used if all elements are shortened by 3 mm. The element lengths are intended for use with a slight chamfer (0.5 mm) cut into the element ends. The gain peak of the array is centered at 437 MHz. This allows acceptable wet-weather performance, while reducing the gain at 432 MHz by only 0.05 dB. The gain bandwidth of the 22-element Yagi is 31 MHz (at the

-1 dB points). The SWR of the Yagi is less than 1.4:1 between 420 and 440 MHz. **Fig 33** is a network analyzer plot of the driven-element SWR vs frequency. These numbers indicate just how wide the frequency response of a log-taper Yagi can be, even with a simple dipole driven element. In fact, at one antenna gain contest, some ATV operators conducted gain vs frequency measurements from 420 to 440 MHz. The 22-element Yagi beat all entrants including those with so-called broadband feeds.

To peak the Yagi for use on 435 MHz (for satellite use), you may want to shorten all the elements by 2 mm. To peak it for use on 438 MHz (for ATV applications), shorten all elements by 4 mm. If you want to use the Yagi on FM between 440 MHz and 450 MHz, shorten all the elements by 10 mm. This will provide 17.6 dBi gain at 440 MHz, and 18.0 dBi gain at 450 MHz. The driven element may have to be adjusted if the element lengths are shortened.

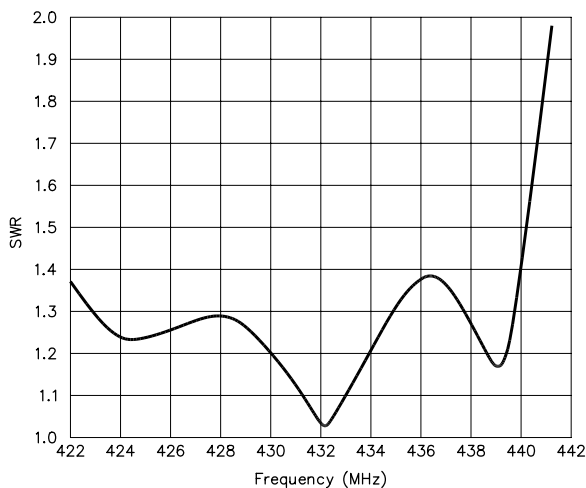
Although this Yagi design is relatively broadband, it is suggested that close attention be paid to copying the design exactly as built. Metric dimensions are used because they are convenient for a Yagi sized for 432 MHz. Element holes should be drilled within  $\pm 2$  mm. Element lengths should be kept within  $\pm 0.5$  mm. Elements can be accurately constructed if they are first rough cut with a hacksaw and then held in a vise and filed to the exact length.

The larger the array, the more attention you should pay to making all Yagis identical. Elements are mounted on shoulder insulators and run through the boom (see **Fig 34**).

**Table 7****Specifications for 432-MHz Family**

No. of El	Boom length ( $\lambda$ )	Gain (dBi)*	FB ratio (dB)	DE impd ( $\Omega$ )	Beamwidth E/H ( $^\circ$ )	Stacking E/H (inches)
15	3.4	15.67	21	23	30 / 32	53 / 49
16	3.8	16.05	19	23	29 / 31	55 / 51
17	4.2	16.45	20	27	28 / 30	56 / 53
18	4.6	16.8	25	32	27 / 29	58 / 55
19	4.9	17.1	25	30	26 / 28	61 / 57
20	5.3	17.4	21	24	25.5 / 27	62 / 59
21	5.7	17.65	20	22	25 / 26.5	63 / 60
22	6.1	17.9	22	25	24 / 26	65 / 62
23	6.5	18.15	27	30	23.5 / 25	67 / 64
24	6.9	18.35	29	29	23 / 24	69 / 66
25	7.3	18.55	23	25	22.5 / 23.5	71 / 68
26	7.7	18.8	22	22	22 / 23	73 / 70
27	8.1	19.0	22	21	21.5 / 22.5	75 / 72
28	8.5	19.20	25	25	21 / 22	77 / 75
29	8.9	19.4	25	25	20.5 / 21.5	79 / 77
30	9.3	19.55	26	27	20 / 21	80 / 78
31	9.7	19.7	24	25	19.6 / 20.5	81 / 79
32	10.2	19.8	23	22	19.3 / 20	82 / 80
33	10.6	19.9	23	23	19 / 19.5	83 / 81
34	11.0	20.05	25	22	18.8 / 19.2	84 / 82
35	11.4	20.2	27	25	18.5 / 19.0	85 / 83
36	11.8	20.3	27	26	18.3 / 18.8	86 / 84
37	12.2	20.4	26	26	18.1 / 18.6	87 / 85
38	12.7	20.5	25	25	18.9 / 18.4	88 / 86
39	13.1	20.6	25	23	18.7 / 18.2	89 / 87
40	13.5	20.8	26	21	17.5 / 18	90 / 88

\*Gain is approximate real gain based on gain measurements made on six different-length Yagis.



**Fig 33—SWR performance of the 22-element Yagi in dry weather.**

**Table 8****Free-Space Dimensions for 432-MHz Yagi Family**

Element lengths are for  $3/16$ -inch-diameter material.

El No.	Element Position (mm from reflector)	Element Length (mm)	Element Correction*
REF	0	340	
DE	104	334	
D1	146	315	
D2	224	306	
D3	332	299	
D4	466	295	
D5	622	291	
D6	798	289	
D7	990	287	
D8	1196	285	
D9	1414	283	
D10	1642	281	-2
D11	1879	279	-2
D12	2122	278	-2
D13	2373	277	-2
D14	2629	276	-2
D15	2890	275	-1
D16	3154	274	-1
D17	3422	273	-1
D18	3693	272	0
D19	3967	271	0
D20	4242	270	0
D21	4520	269	0
D22	4798	269	0
D23	5079	268	0
D24	5360	268	+1
D25	5642	267	+1
D26	5925	267	+1
D27	6209	266	+1
D28	6494	266	+1
D29	6779	265	+2
D30	7064	265	+2
D31	7350	264	+2
D32	7636	264	+2
D33	7922	263	+2
D34	8209	263	+2
D35	8496	262	+2
D36	8783	262	+2
D37	9070	261	+3
D38	9359	261	+3

\*Element correction is the amount to shorten or lengthen all elements when building a Yagi of that length.

The element retainers are stainless steel push nuts. These are made by several companies, including Industrial Retaining Ring Co in Irvington, New Jersey, and AuVeco in Ft Mitchell, Kentucky. Local industrial hardware distributors can usually order them for you. The element insulators are not critical. Teflon or black polyethylene are probably the best materials. The Yagi in the photographs is made with black Delryn insulators, available from Rutland Arrays in New Cumberland, Pennsylvania.

The driven element uses a UG-58A/U connector mounted on a small bracket. The UG-58A/U should be the type with the press-in center pin. UG-58s with center pins held in by “C” clips will usually leak water. Some connectors use steel retaining clips, which will rust and leave a conductive stripe across the insulator. The T-match wires are supported by the UT-141 balun. RG-303/U or RG-142/U Teflon-insulated cable could be used if UT-141 cannot be obtained. Fig 35A and Fig 35B show details of the driven-element

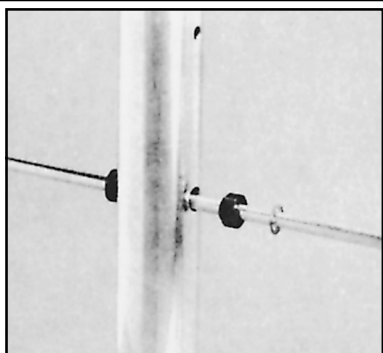
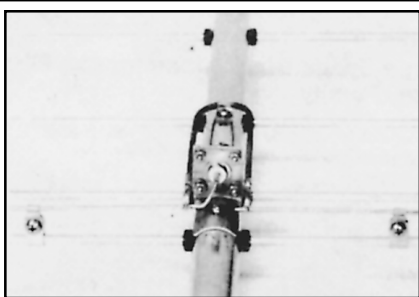
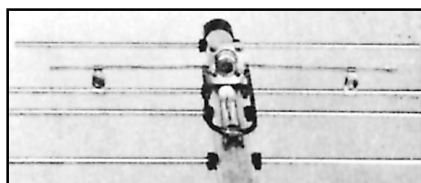


Fig 34—Element-mounting detail. Elements are mounted through the boom using plastic insulators. Stainless steel push-nut retaining rings hold the element in place.



(A)



(B)

Fig 35—Several views of the driven element and T match.

construction. Driven element dimensions are given in Fig 36.

Dimensions for the 22-element Yagi are listed in Table 9. Fig 37 details the Yagi’s boom layout. Element material can be either 3/16-inch 6061-T6 aluminum rod or hard aluminum welding rod.

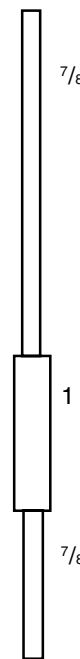
A 24-foot-long, 10.6-λ, 33-element Yagi was also built. The construction methods used were the same as the 22-element Yagi. Telescoping round boom sections of 1, 1 1/8, and 1 1/4 inches in diameter were used. A boom support is required to keep boom sag acceptable. At 432 MHz, if boom sag is much more than two or three inches, H-plane pattern distortion will occur. Greater amounts of boom sag will reduce the gain of a Yagi. Table 10 lists the proper dimensions for the antenna when built with the previously given boom diameters. The boom layout is shown in Fig 38, and the driven element is described in Fig 39. The 33-element Yagi exhibits the same clean pattern traits as the 22-element Yagi (see Fig 40). Measured gain of the 33-element Yagi is 19.9 dBi at 432 MHz. A measured gain sweep of the 33-element Yagi gave a -1 dB gain bandwidth of 14 MHz with the -1 dB points at 424.5 MHz and 438.5 MHz.

### A HIGH-PERFORMANCE 144-MHz YAGI

This 144-MHz Yagi design uses the latest log-tapered element spacings and lengths. It offers near-theoretical gain per boom length, an extremely clean pattern and wide

Table 9  
Dimensions for the 22-Element 432-MHz Yagi

Element Number	Element Position (mm from reflector)	Element Length (mm)	Boom Diam (in)
REF	30	346	
DE	134	340	
D1	176	321	
D2	254	311	
D3	362	305	
D4	496	301	
D5	652	297	
D6	828	295	
D7	1020	293	
D8	1226	291	
D9	1444	289	
D10	1672	288	
D11	1909	286	
D12	2152	285	
D13	2403	284	
D14	2659	283	
D15	2920	281	
D16	3184	280	
D17	3452	279	
D18	3723	278	
D19	3997	277	
D20	4272	276	

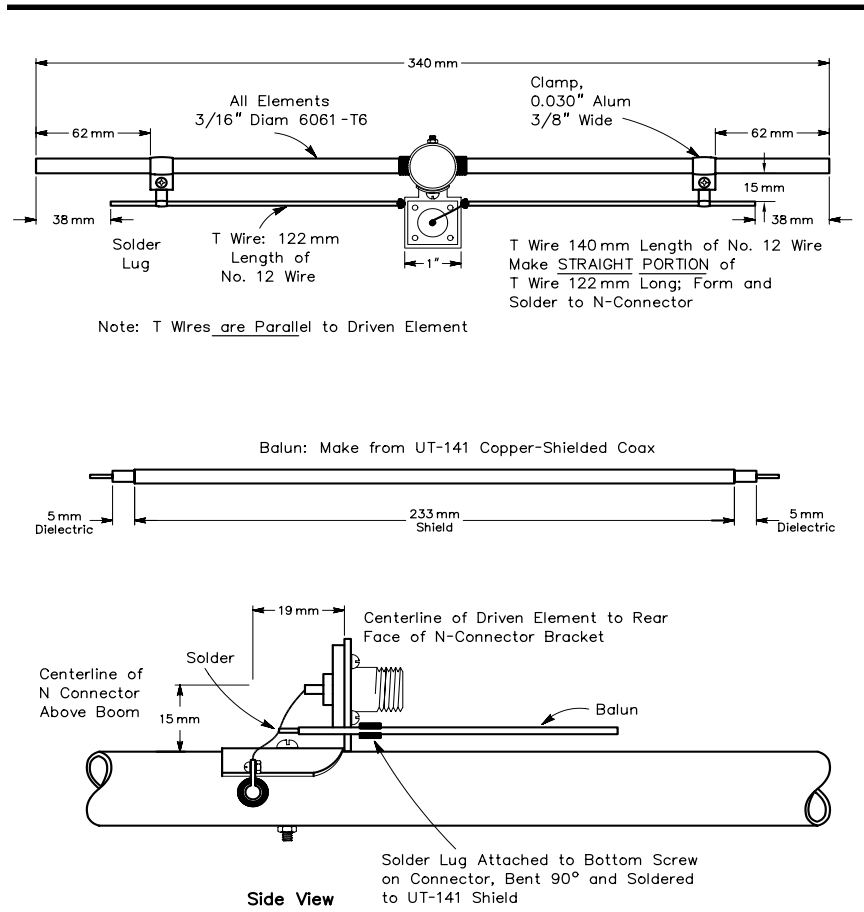


bandwidth. The design is based on the spacings used in a  $4.5\text{-}\lambda$  432-MHz computer-developed design by WIEJ. It is quite similar to the 432-MHz Yagi described elsewhere in this chapter. Refer to that project for additional construction diagrams and photographs.

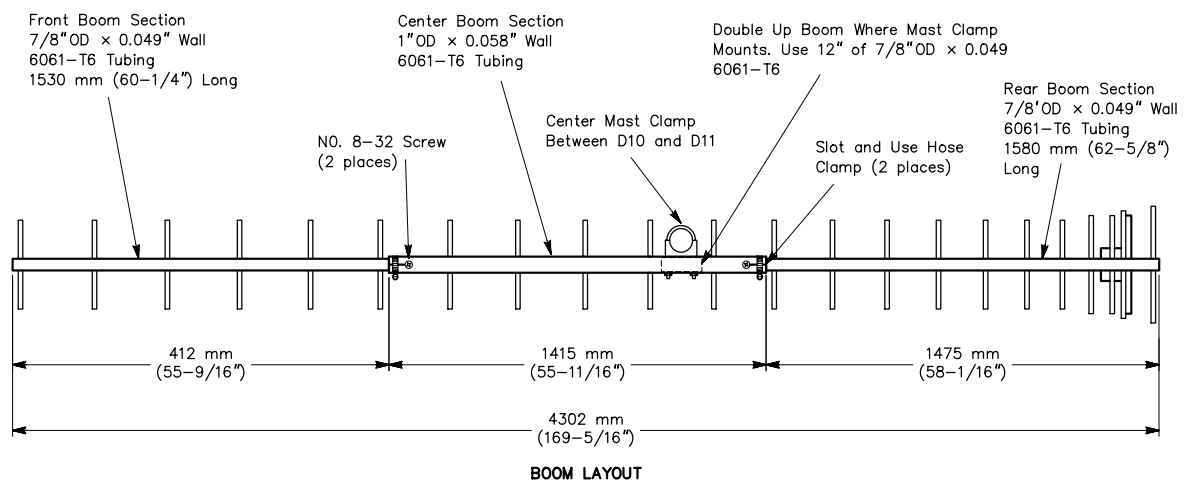
Mathematical models do not always directly translate into real working examples. Although the computer design provided a good starting point, the author, Steve Powlisken, K1FO, built several test models before the final working Yagi was obtained. This hands-on tuning included changing the element-taper rate in order to obtain the flexibility that allows the Yagi to be built with different boom lengths.

The design is suitable for use from  $1.8\lambda$  (10 elements) to  $5.1\lambda$  (19 elements). When elements are added to a Yagi, the center frequency, feed impedance and front-to-back ratio will range up and down. A modern tapered design will minimize this effect and allow the builder to select any desired boom length. This Yagi's design capabilities per boom length are listed in [Table 11](#).

The gain of any Yagi built around this design will be within 0.1 to 0.2 dB of the maximum theoretical gain at the design frequency of 144.2 MHz. The



**Fig 36—Details of the driven element and T match for the 22-element Yagi. Lengths are given in millimeters to allow precise duplication of the antenna. See text.**



**Fig 37—Boom-construction information for the 22-element Yagi. Lengths are given in millimeters to allow precise duplication of the antenna. See text.**

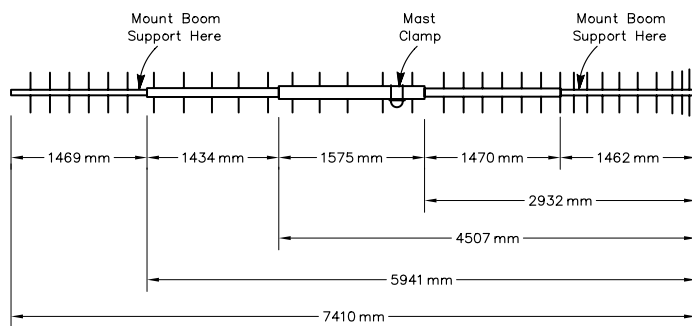
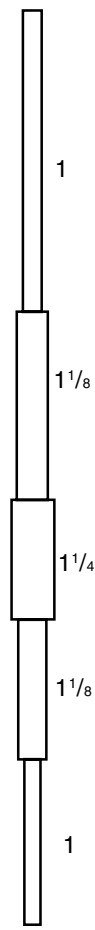
design is intentionally peaked high in frequency (calculated gain peak is about 144.7 MHz). It has been found that by doing this, the SWR bandwidth and pattern at 144.0 to 144.3 MHz will be better, the Yagi will be less affected by weather and its performance in arrays will be more predictable. This design starts to drop off in performance if built with fewer than 10 elements. At less than  $2\lambda$ , more traditional designs perform well.

**Table 12** gives free-space element lengths for  $1/4$ -inch-diameter elements. The use of metric notation allows for much easier dimensional changes during the design stage. Once you become familiar with the metric system, you'll probably find that construction is easier without the burden of cumbersome English fractional units. For  $3/16$ -inch-diameter elements, lengthen all parasitic elements by 3 mm. If  $3/8$ -inch-diameter elements are used, shorten all of the directors and the reflector by 6 mm. The driven element will have to be adjusted for the individual Yagi if the 12-element design is not adhered to.

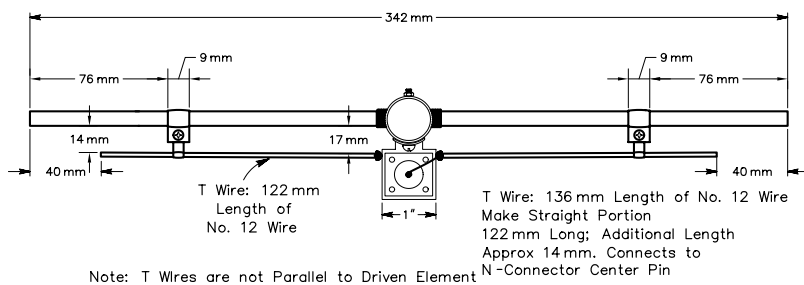
For the 12-element Yagi,  $1/4$ -inch-diameter elements were selected because smaller-diameter elements become rather flimsy at 2 meters. Other diameter elements can be used as described previously. The  $2.5\lambda$  boom was chosen because it has an excellent size and wind load vs gain and pattern trade-off. The size is also convenient; three 6-foot-long pieces of aluminum tubing can be used without any waste. The relatively large-diameter boom sizes ( $1 1/4$  and  $1 3/8$  inches) were chosen, as they provide an extremely rugged Yagi that

**Table 10**  
**Dimensions for the**  
**33-Element 432-MHz Yagi**

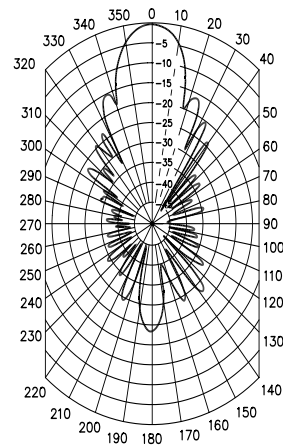
Element Number	Element Position (mm from reflector)	Element Length (mm)	Boom Diam (in)
REF	30	348	1
DE	134	342	
D1	176	323	
D2	254	313	
D3	362	307	
D4	496	303	
D5	652	299	
D6	828	297	
D7	1020	295	
D8	1226	293	
D9	1444	291	
D10	1672	290	
D11	1909	288	
D12	2152	287	
D13	2403	286	
D14	2659	285	
D15	2920	284	
D16	3184	284	
D17	3452	283	
D18	3723	282	
D19	3997	281	
D20	4272	280	
D21	4550	278	
D22	4828	278	
D23	5109	277	
D24	5390	277	
D25	5672	276	
D26	5956	275	
D27	6239	274	
D28	6524	274	
D29	6809	273	
D30	7094	273	
D31	7380	272	



**Fig 38—Boom-construction information for the 33-element Yagi. Lengths are given in millimeters to allow precise duplication of the antenna.**



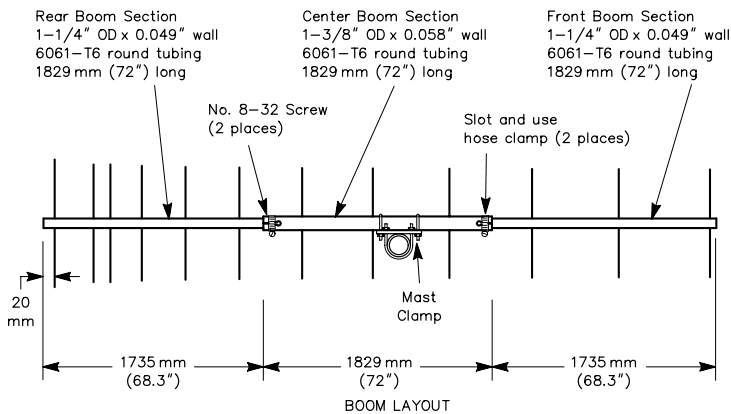
**Fig 39—Details of the driven element and T match for the 33-element Yagi. Lengths are given in millimeters to allow precise duplication of the antenna.**



**Fig 40—E-plane pattern for the 33-element Yagi. This pattern is drawn on a linear dB grid scale, rather than the standard ARRL log-periodic grid, to emphasize low sidelobes.**

**Table 11**  
**Specifications for the 144-MHz Family**

No. of El	Boom Length ( $\lambda$ )	Gain (dBd)	DE impd ( $\Omega$ )	FB Ratio (dB)	Beamwidth	Stacking
					E/H ( $^\circ$ )	E/H ( $^\circ$ )
10	1.8	11.4	27	17	39 / 42	10.2 / 9.5
11	2.2	12.0	38	19	36 / 40	11.0 / 10.0
12	2.5	12.5	28	23	34 / 37	11.7 / 10.8
13	2.9	13.0	23	20	32 / 35	12.5 / 11.4
14	3.2	13.4	27	18	31 / 33	12.8 / 12.0
15	3.6	13.8	35	20	30 / 32	13.2 / 12.4
16	4.0	14.2	32	24	29 / 30	13.7 / 13.2
17	4.4	14.5	25	23	28 / 29	14.1 / 13.6
18	4.8	14.8	25	21	27 / 28.5	14.6 / 13.9
19	5.2	15.0	30	22	26 / 27.5	15.2 / 14.4



**Fig 41—Boom layout for the 12-element 144-MHz Yagi. Lengths are given in millimeters to allow precise duplication.**

does not require a boom support. The 12-element 17-foot-long design has a calculated wind survival of close to 120 mi/h! The absence of a boom support also makes vertical polarization possible.

Longer versions could be made by telescoping smaller-size boom sections into the last section. Some sort of boom support will be required on versions longer than 22 feet. The elements are mounted on shoulder insulators and mounted through the boom. However, elements may be mounted, insulated or uninsulated, above or through the boom, as long as appropriate element length corrections are made. Proper tuning can be verified by checking the depth of the nulls between the main lobe and first side lobes. The nulls should be 5 to 10 dB below the first side-lobe level at the primary operating frequency. The boom layout for the 12-element model is shown in **Fig 41**. The actual corrected element dimensions for the 12-element 2.5- $\lambda$  Yagi are shown in **Table 13**.

The design may also be cut for use at 147 MHz. There is no need to change element spacings. The element lengths should be shortened by 17 mm for best operation between 146 and 148 MHz. Again, the driven element will have to

**Table 12**  
**Free-Space Dimensions for the 144-MHz Yagi Family**

Element diameter is  $\frac{1}{4}$  inch.

El No.	Element Position (mm from reflector)	Element Length
REF	0	1038
DE	312	955
D1	447	956
D2	699	932
D3	1050	916
D4	1482	906
D5	1986	897
D6	2553	891
D7	3168	887
D8	3831	883
D9	4527	879
D10	5259	875
D11	6015	870
D12	6786	865
D13	7566	861
D14	8352	857
D15	9144	853
D16	9942	849
D17	10744	845

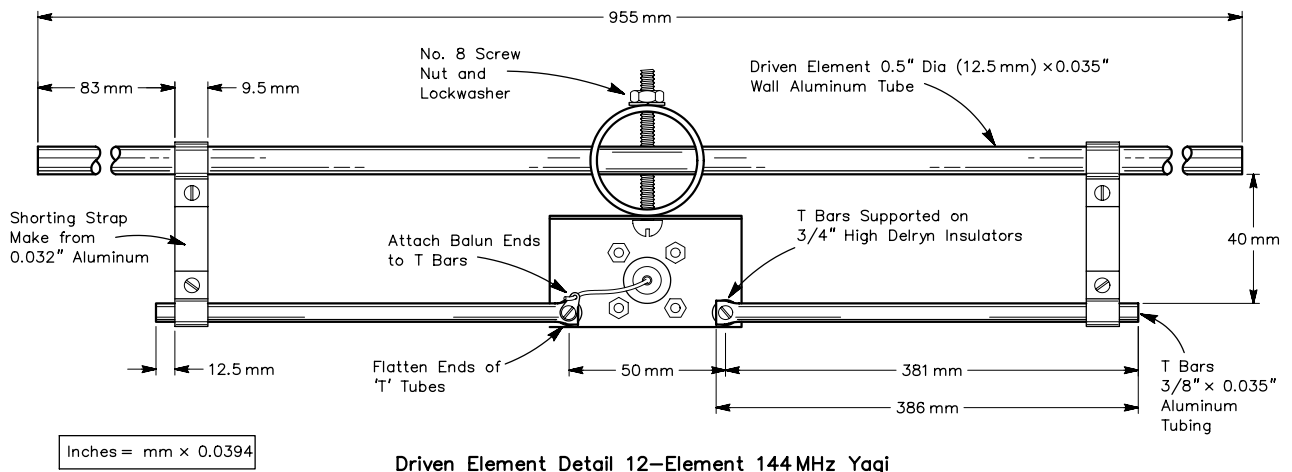
**Table 13**  
**Dimensions for the 12-Element 2.5- $\lambda$  Yagi**

Element Number	Element Position (mm from reflector)	Element Length (mm)	Boom Diam (in)
REF	0	1044	
DE	312	955	
D1	447	962	
D2	699	938	$1\frac{1}{4}$
D3	1050	922	
D4	1482	912	
D5	1986	904	
D6	2553	898	$1\frac{3}{8}$
D7	3168	894	
D8	3831	889	
D9	4527	885	
D10	5259	882	$1\frac{1}{4}$

be adjusted as required.

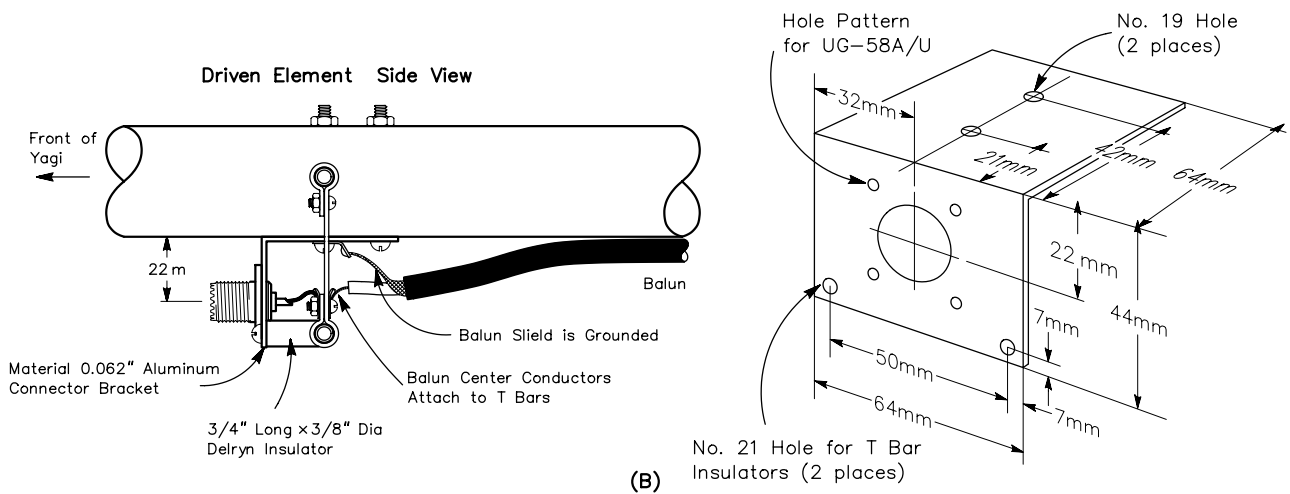
The driven-element size ( $\frac{1}{2}$ -inch diameter) was chosen to allow easy impedance matching. Any reasonably sized driven element could be used, as long as appropriate length and T-match adjustments are made. Different driven-element dimensions are required if you change the boom length. The calculated natural driven-element impedance is given as a guideline. A balanced T-match was chosen because it's easy to adjust for best SWR and provides a balanced radiation



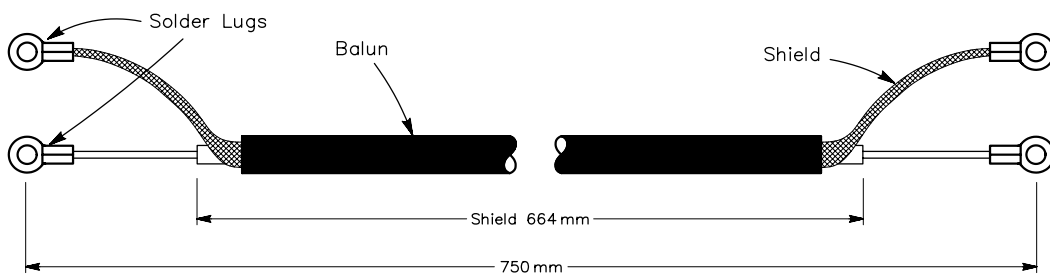


Driven Element Detail 12-Element 144 MHz Yagi

(A)



(B)



Material: RG-142/U or RG-303/U Teflon-Insulated Coaxial Cable

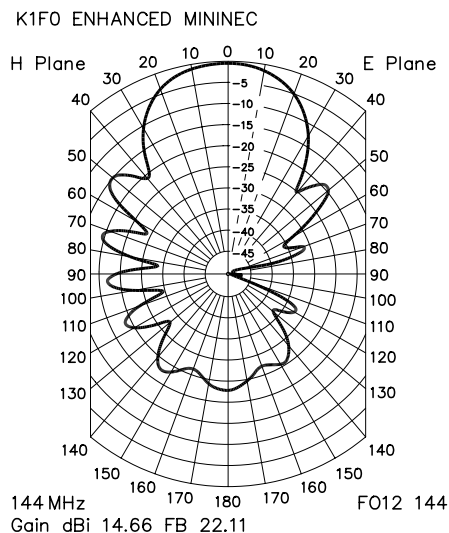
(C)

Fig 42—Driven-element detail for the 12-element 144-MHz Yagi. Lengths are given in millimeters to allow precise duplication.

pattern. A 4:1 half-wave coaxial balun is used, although impedance-transforming quarter-wave sleeve baluns could also be used. The calculated natural impedance will be useful in determining what impedance transformation will be required at the 200-Ω balanced feed point. *The ARRL Antenna Book* contains information on calculating folded-dipole and T-match driven-element parameters. A balanced feed is important for best operation on this antenna. Gamma matches can severely distort the pattern balance. Other useful driven-element arrangements are the Delta match and the folded dipole, if you're willing to sacrifice some flexibility. **Fig 42** details the driven-element dimensions.

A noninsulated driven element was chosen for mounting convenience. An insulated driven element may also be used. A grounded driven element may be less affected by static build-up. On the other hand, an insulated driven element allows the operator to easily check his feed lines for water or other contamination by the use of an ohmmeter from the shack.

**Fig 43** shows computer-predicted E and H-plane radiation patterns for the 12-element Yagi. The patterns are



**Fig 43—H and E-plane pattern for the 12-element 144-MHz Yagi.**

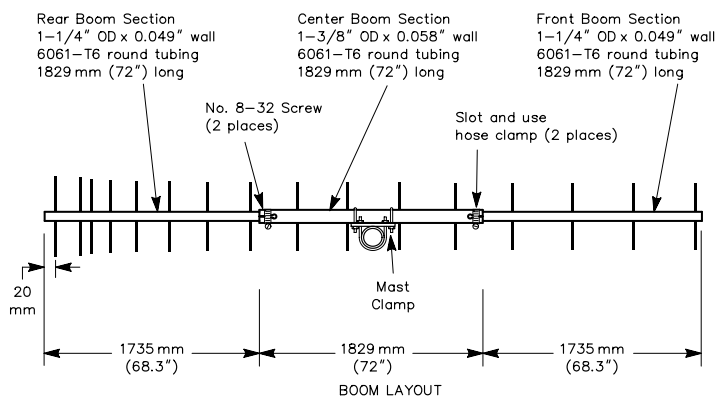
**Table 14**  
**Free-Space Dimensions for the 222-MHz Yagi Family**

Element diameter is  $3/16$  inch.

El No.	Element Position (mm from reflector)	Element Length (mm)
REF	0	676
DE	204	647
D1	292	623
D2	450	608
D3	668	594
D4	938	597
D5	1251	581
D6	1602	576
D7	1985	573
D8	2395	569
D9	2829	565
D10	3283	562
D11	3755	558
D12	4243	556
D13	4745	554
D14	5259	553
D15	5783	552
D16	6315	551
D17	6853	550
D18	7395	549
D19	7939	548
D20	8483	547

**Table 15**  
**Specifications for the 222-MHz Family**

No. of El	Boom Length ( $\lambda$ )	Gain (dBd)	FB Ratio (dB)	DE Impd ( $\Omega$ )	Beamwidth E/H ( $^\circ$ )	Stacking E/H (feet)
12	2.4	12.3	22	23	37 / 39	7.1 / 6.7
13	2.8	12.8	19	28	33 / 36	7.8 / 7.2
14	3.1	13.2	20	34	32 / 34	8.1 / 7.6
15	3.5	13.6	24	30	30 / 33	8.6 / 7.8
16	3.9	14.0	23	23	29 / 31	8.9 / 8.3
17	4.3	14.35	20	24	28 / 30.5	9.3 / 8.5
18	4.6	14.7	20	29	27 / 29	9.6 / 8.9
19	5.0	15.0	22	33	26 / 28	9.9 / 9.3
20	5.4	15.3	24	29	25 / 27	10.3 / 9.6
21	5.8	15.55	23	24	24.5 / 26.5	10.5 / 9.8
22	6.2	15.8	21	23	24 / 26	10.7 / 10.2

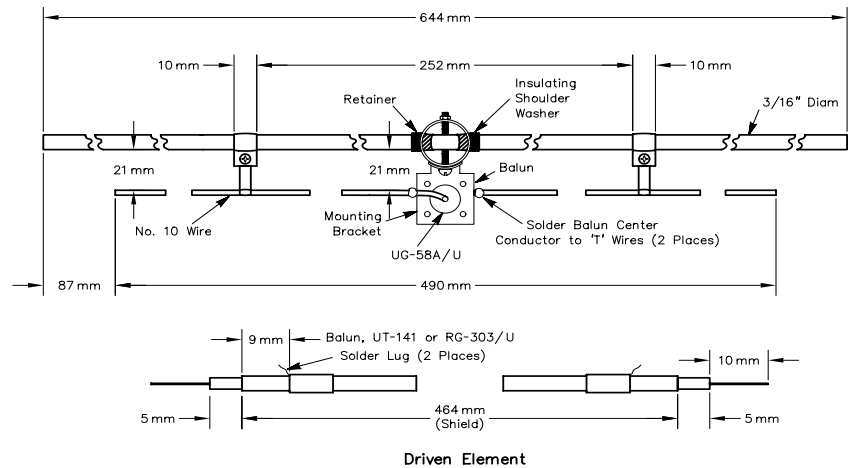


**Fig 44—Boom layout for the 16-element 222-MHz Yagi. Lengths are given in millimeters to allow precise duplication.**

**Table 16**

**Dimensions for 16-Element 3.9-λ 222-MHz Yagi**

Element Number	Element Position (mm from reflector)	Element Length (mm)	Boom Diam (in)
REF		683	1 1/4
DE	204	664	1 3/8
D1	292	630	1 1/4
D2	450	615	
D3	668	601	
D4	938	594	
D5	1251	588	
D6	1602	583	
D7	1985	580	
D8	2395	576	
D9	2829	572	
D10	3283	569	
D11	3755	565	
D12	4243	563	
D13	4745	561	
D14	5259	560	



**Fig 45—Driven-element detail for the 16-element 222-MHz Yagi. Lengths are given in millimeters to allow precise duplication.**

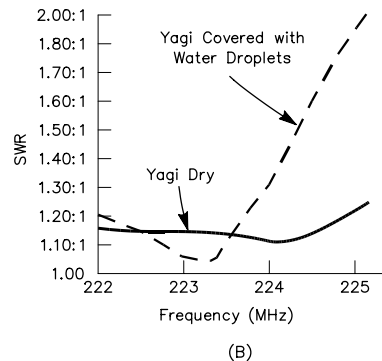
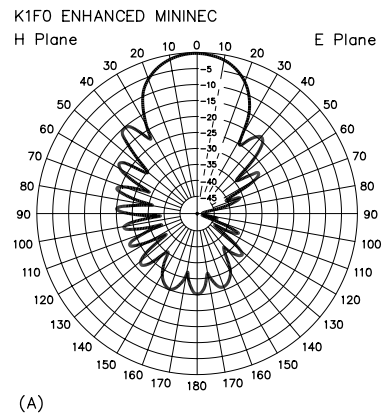
plotted on a 1-dB-per-division linear scale instead of the usual ARRL polar-plot graph. This expanded scale plot is used to show greater pattern detail. The pattern for the 12-element Yagi is so clean that a plot done in the standard ARRL format would be almost featureless, except for the main lobe and first sidelobes.

The excellent performance of the 12-element Yagi is demonstrated by the reception of Moon echoes from several of the larger 144-MHz EME stations with only one 12-element Yagi. Four of the 12-element Yagis will make an excellent starter EME array, capable of working many EME QSOs while being relatively small in size. The advanced antenna builder can use the information in Table 11 to design a “dream” array of virtually any size.

**A HIGH-PERFORMANCE 222-MHz YAGI**

Modern tapered Yagi designs are easily applied to 222 MHz. This design uses a spacing progression that is in between the 12-element 144-MHz design, and the 22-element 432-MHz design presented elsewhere in this chapter. The result is a design with maximum gain per boom length, a clean, symmetrical radiation pattern, and wide bandwidth. Although it was designed for weak-signal work (tropospheric scatter and EME), the design is suited to all modes of 222-MHz operation, such as packet radio, FM repeater operation and control links.

The spacings were chosen as the best compromise for a 3.9-λ 16-element Yagi. The 3.9-λ design was chosen, like the 12-element 144-MHz design, because it fits perfectly on a boom made from three 6-foot-long aluminum tubing sections. The design is quite extensible, and models from



**Fig 46—H and E-plane patterns for the 16-element 222-MHz Yagi at A. The driven-element T-match dimensions were chosen for the best SWR compromise between wet and dry weather conditions. The SWR vs frequency curve shown at B demonstrates the broad frequency response of the Yagi design.**

12 elements ( $2.4 \lambda$ ) to 22 elements ( $6.2 \lambda$ ) can be built from the dimensions given in **Table 14**. Note that free-space lengths are given. They must be corrected for the element mounting method. Specifications for various boom lengths are shown in **Table 15**.

### Construction

Large-diameter ( $1\frac{1}{4}$  and  $1\frac{3}{8}$ -inch diameter) boom construction is used, eliminating the need for boom supports. The Yagi can also be used vertically polarized. Three-sixteenths-inch-diameter aluminum elements are used. The exact alloy is not critical; 6061-T6 was used, but hard aluminum welding rod is also suitable. Quarter-inch-diameter elements could also be used if all elements are shortened by 3 mm. Three-eighths-inch-diameter elements would require 10 mm shorter lengths. Elements smaller than  $\frac{3}{16}$ -inch-diameter are not recommended. The elements are insulated and run through the boom. Plastic shoulder washers and stainless steel retainers are used to hold the elements in place. The various pieces needed to build the Yagi may be obtained from Rutland Arrays in New Cumberland, Pennsylvania. **Fig 44** details the boom layout for the 16-element Yagi. **Table 16** gives the dimensions for the 16-element Yagi as built. The driven element is fed with a T match and a 4:1 balun. See **Fig 45** for construction details. See the 432-MHz Yagi project elsewhere in this chapter for additional photographs and construction diagrams.

The Yagi has a relatively broad gain and SWR curve, as is typical of a tapered design, making it usable over a wide frequency range. The example dimensions are intended

for use at 222.0 to 222.5 MHz. The 16-element Yagi is quite usable to more than 223 MHz. The best compromise for covering the entire band is to shorten all parasitic elements by 4 mm. The driven element will have to be adjusted in length for best match. The position of the T-wire shorting straps may also have to be moved.

The aluminum boom provides superior strength, is lightweight, and has a low wind-load cross section. Aluminum is doubly attractive, as it will long outlast wood and fiberglass. Using state-of-the-art designs, it is unlikely that significant performance increases will be achieved in the next few years. Therefore, it's in your best interest to build an antenna that will last many years. If suitable wood or fiberglass poles are readily available, they may be used without any performance degradation, at least when the wood is new and dry. Use the free-space element lengths given in **Table 16** for insulated-boom construction.

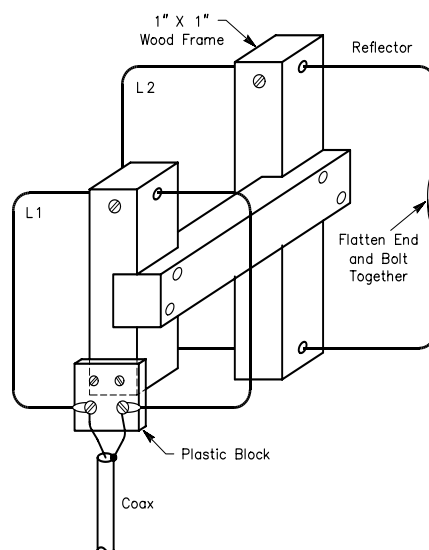
The pattern of the 16-element Yagi is shown in **Fig 46**. Like the 144-MHz Yagi, a 1-dB-per-division plot is used to detail the pattern accurately. This 16-element design makes a good building block for EME or tropo DX arrays. Old-style narrow-band Yagis often perform unpredictably when used in arrays. The theoretical 3.0-dB stacking gain is rarely observed. The 16-element Yagi (and other versions of the design) reliably provides stacking gains of nearly 3 dB. (The spacing dimensions listed in **Table 15** show just over 2.9 dB stacking gain.) This has been found to be the best compromise between gain, pattern integrity and array size. Any phasing line losses will subtract from the possible stacking gain. Mechanical misalignment will also degrade the performance of an array.

## A 144-MHz 2-Element Quad

The basic 2-element quad array for 144 MHz is shown in **Fig 47**. The supporting frame is 1 × 1-inch wood, of any kind suitable for outdoor use. Elements are #8 aluminum wire. The driven element is  $1 \lambda$  (83 inches) long, and the reflector 5% longer (87 inches). Dimensions are not critical, as the quad is relatively broad in frequency response.

The driven element is open at the bottom, its ends fastened to a plastic block. The block is mounted at the bottom of the forward vertical support. The top portion of the element runs through the support and is held firmly by a screw running into the wood and then bearing on the aluminum wire. Feed is by means of 50-Ω coax, connected to the driven-element loop.

**Fig 47—Mechanical details of a 2-element quad for 144 MHz. The driven element, L1, is one wavelength long; reflector L2 is 5% longer. With the transmission line connected as shown here, the resulting radiation is horizontally polarized. Sets of elements of this type can be stacked horizontally and vertically for high gain with broad frequency response. Recommended bay spacing is  $\frac{1}{2} \lambda$  between adjacent element sides. The example shown may be fed directly with 50-Ω coax.**



The reflector is a closed loop, its top and bottom portions running through the rear vertical support. It is held in position with screws at the top and bottom. The loop can be closed by fitting a length of tubing over the element ends, or by hammering them flat and bolting them together as shown in the sketch.

The elements in this model are not adjustable, though this can easily be done by the use of stubs. It would then be desirable to make the loops slightly smaller to compensate for the wire in the adjusting stubs. The driven element stub would be trimmed for length and the point of connection for

the coax would be adjustable for best match. The reflector stub can be adjusted for maximum gain or maximum F/B ratio, depending on the builder's requirements.

In the model shown only the spacing is adjusted, and this is not particularly critical. If the wooden supports are made as shown, the spacing between the elements can be adjusted for best match, as indicated by an SWR meter connected in the coaxial line. The spacing has little effect on the gain (from  $0.15 \lambda$  to  $0.25 \lambda$ ), so the variation in impedance with spacing can be used for matching. This also permits use of either 50 or 75- $\Omega$  coax for the transmission line.

## A Portable 144-MHz 4-Element Quad

Element spacing for quad antennas found in the literature ranges from  $0.14 \lambda$  to  $0.25 \lambda$ . Factors such as the number of elements in the array and the parameters to be optimized (F/B ratio, forward gain, bandwidth, etc), determine the optimum element spacing within this range.



Fig 48—The 4-element 144-MHz portable quad, assembled and ready for operation. Sections of clothes-closet poles joined with pine strips make up the mast. (Photo by Adwin Rusczek, W1MPO)

The 4-element quad antenna described here was designed for portable use, so a compromise between these factors was chosen. This antenna, pictured in Fig 48, was designed and built by Philip D'Agostino, W1KSC.

Based on several experimentally determined correction factors related to the frequency of operation and the wire size, optimum design dimensions were found to be as follows.

$$\text{Reflector length (ft)} = \frac{1046.8}{f_{\text{MHz}}} \quad (\text{Eq 8})$$

$$\text{Driven element (ft)} = \frac{985.5}{f_{\text{MHz}}} \quad (\text{Eq 9})$$

$$\text{Directors (ft)} = \frac{937.3}{f_{\text{MHz}}} \quad (\text{Eq 10})$$

Cutting the loops for 146 MHz provides satisfactory performance across the entire 144-MHz band.



Fig 49—The complete portable quad, broken down for travel. Visible in the foreground is the driven element. The pine box in the background is a carrying case for equipment and accessories. A hole in the lid accepts the mast, so the box doubles as a base for a short mast during portable operation. (W1MPO photo)

## Materials

The quad was designed for quick and easy assembly and disassembly, as illustrated in Fig 49. Wood (clear trim pine) was chosen as the principal building material because of its light weight, low cost, and ready availability. Pine is used for the boom and element supporting arms. Round wood clothes-closet poles comprise the mast material. Strips connecting the mast sections are made of heavier pine trim. Elements are made of #8 aluminum wire. Plexiglas is used to support the feed point. Table 17 lists the hardware and other parts needed to duplicate the quad.

## Construction

The elements of the quad are assembled first. The mounting holes in the boom should be drilled to accommodate 1/2 inch no. 8 hardware. Measure and mark the locations where the holes are to be drilled in the element spreaders, Fig 50. Drill the holes in the spreaders just large enough to accept the #8 wire elements. It is important to drill all the holes straight so the elements line up when the antenna is assembled.

Construction of the wire elements is easiest if the directors are made first. A handy jig for bending the elements can be made from a piece of 2 x 3-inch wood cut to the side length of the directors. It is best to start with about 82 inches of wire for each director. The excess can be cut off when the elements are completed. (The total length of each director is 77 inches.) Two bends should initially be made so the directors can be slipped into the spreaders before the remaining corners are bent. See Fig 51. Electrician's copper-wire clamps can be used to join the wires after the final bends are made, and they facilitate adjustment of element length. The reflector is made the same way as the directors, but the total length is 86 inches.

The driven element, total length 81 inches, requires special attention, as the feed attachment point needs to be adequately supported. An extra hole is drilled in the driven element spreader to support the feed-point strut, as shown in Fig 52. A Plexiglas plate is used at the feed point to support the feed-point hardware and the feed line. The feed-point

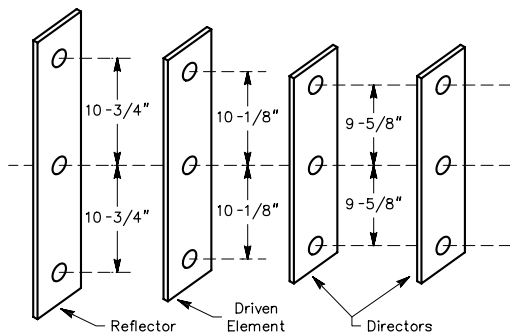


Fig 50—Dimensions for the pine element spreaders for the 144-MHz 4-element quad.

Table 17

### Parts List for the 144-MHz 4-element Quad

Boom:	$\frac{3}{4} \times \frac{3}{4}$ 48-in. pine
Driven element support (spreader):	$\frac{1}{2} \times \frac{3}{4} \times 21\frac{1}{4}$ in. pine
Driven element feed-point strut:	$\frac{1}{2} \times \frac{3}{4} \times 7\frac{1}{2}$ in. pine
Reflector support (spreader):	$\frac{1}{2} \times \frac{3}{4} \times 22\frac{1}{2}$ in. pine
Director supports (spreaders):	$\frac{1}{2} \times \frac{3}{4} \times 20\frac{1}{4}$ in. pine, 2 req'd
Mast brackets:	$\frac{3}{4} \times 1\frac{1}{2} \times 12$ in. heavy pine trim, 4 req'd
Boom to mast bracket:	$\frac{1}{2} \times 1\frac{5}{8} \times 5$ in. pine
Element wire:	Aluminum ground wire (Radio Shack no. 15-035)
Wire clamps:	$\frac{1}{4}$ -in. electrician's copper or zinc plated steel clamps, 3 req'd
Boom hardware:	
	6 no. 8-32 x $1\frac{1}{2}$ in. stainless steel machine screws
	6 no. 8-32 stainless steel wing nuts
	12 no. 8 stainless steel washers
Mast hardware:	
	8 hex bolts, $\frac{1}{4}$ -20 x $3\frac{1}{2}$ in.
	8 hex nuts, $\frac{1}{4}$ -20
	16 flat washers
Mast material:	$1\frac{5}{16}$ in. x 6 ft wood clothes-closet poles, 3 req'd
Feed-point support plate:	$3\frac{1}{2} \times 2\frac{1}{2}$ in. Plexiglas sheet
Wood preparation materials:	Sandpaper, clear polyurethane, wax
Feed line:	52Ω RG-8 or RG-58 cable
Feed-line terminals:	Solder lugs for no. 8 or larger hardware, 2 req'd
Miscellaneous hardware:	
	4 small machine screws, nuts, washers; 2 flat-head wood screws

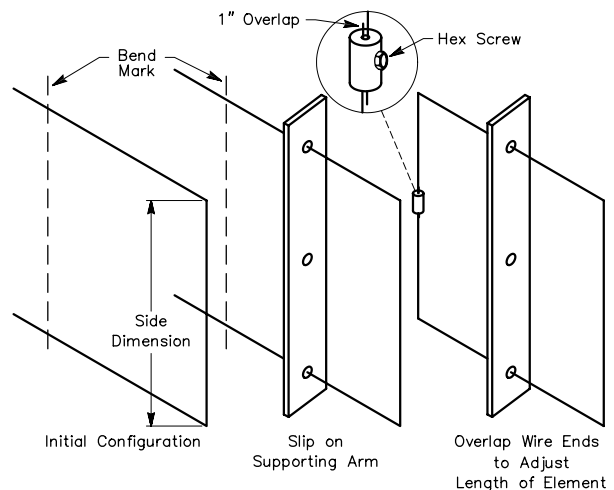
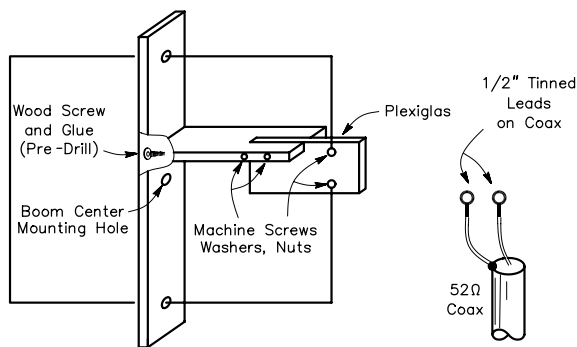
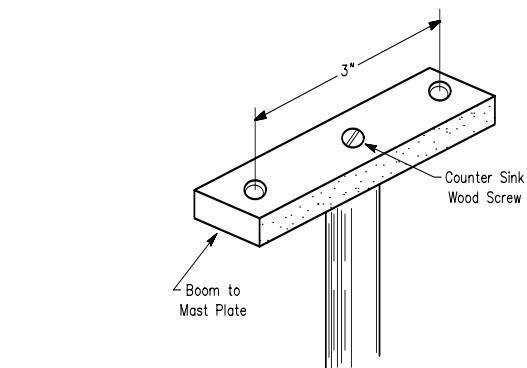


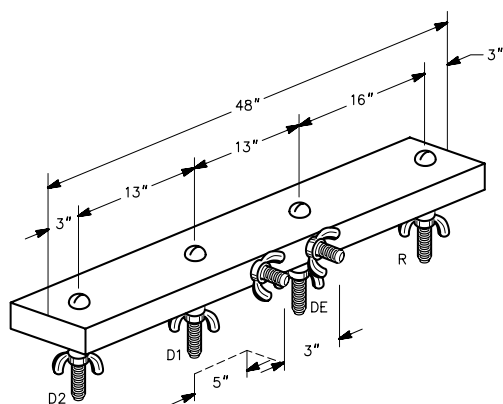
Fig 51—Illustration showing how the aluminum element wires are bent. The adjustment clamp and its location are also shown.



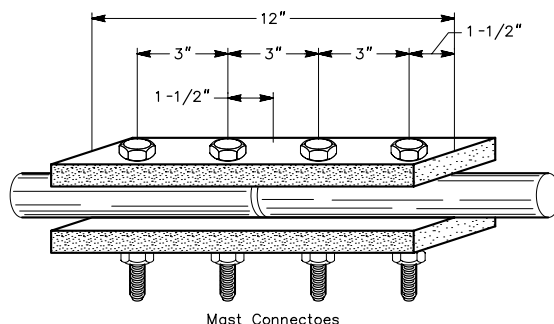
**Fig 52—Layout of the driven element of the 144-MHz quad. The leads of the coaxial cable should be stripped to 1/2 inch and solder lugs attached for easy connection and disconnection. See text regarding impedance at loop support points.**



**Fig 54—Boom-to-mast plate for the 144-MHz quad. The screw hole in the center of the plate should be countersunk so the wood screw attaching it to the mast does not interfere with the fit of the boom.**



**Fig 53—Detail of the boom showing hole center locations and boom-to-mast connection points.**



**Fig 55—Mast coupling connector details for the portable quad. The plates should be drilled two at a time to ensure the holes line up.**

support strut should be epoxied to the spreader, and a wood screw used for extra mechanical strength.

For vertical polarization, locate the feed point in the center of one side of the driven element, as shown in Fig 52. Although this arrangement places the spreader supports at voltage maxima points on the four loop conductors, D'Agostino reports no adverse effects during operation. However, if the antenna is to be left exposed to the weather, the builder may wish to modify the design to provide support for the loops at current maxima points, such as shown in Fig 52. (The elements of Fig 52 should be rotated 90° for vertical polarization.)

Orient the driven element spreader so that it mounts properly on the boom when the antenna is assembled. Bend the driven element the same way as the reflector and directors, but do not leave any overlap at the feed point. The ends of the wires should be 3/4 inch apart where they mount on the Plexiglas plate. Leave enough excess that small loops can be bent in the wire for attachment to the coaxial feed line with stainless steel hardware.

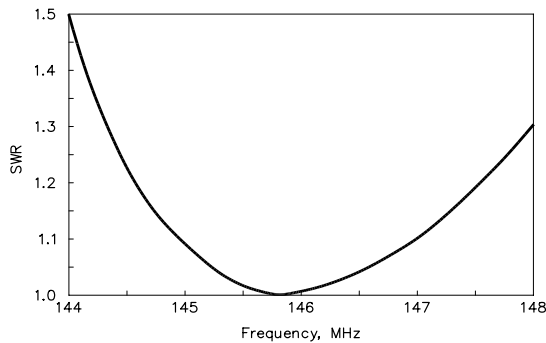
Drill the boom as shown in Fig 53. It is a good idea to

use hardware with wing nuts to secure the element spreaders to the boom. After the boom is drilled, clean all the wood parts with denatured alcohol, sand them, and give them two coats of glossy polyurethane. After the polyurethane dries, wax all the wooden parts.

The boom to mast attachment is made next. Square the ends of a 6-foot section of clothes closet pole (a miter box is useful for this). Drill the center holes in both the boom attachment piece and one end of the mast section (Fig 54). Make certain that the mast hole is smaller than the flat-head screw to be used to ensure a snug fit. Accurately drill the holes for attachment to the boom as shown in Fig 54.

Countersink the hole for the flat-head screw to provide a smooth surface for attachment to the boom. Apply epoxy cement to the surfaces and screw the boom attachment piece securely to the mast section. One 6-foot mast is used for attachment to the other mast sections.

Two additional 6-foot mast sections are prepared next. This brings the total mast height to 18 feet. It is important to square the ends of each pole so the mast stands straight when assembled. Mast-section connectors are made of pine as



**Fig 56—Typical SWR curve for the 144-MHz portable quad. The large wire diameter and the quad design provide excellent bandwidth.**

shown in **Fig 55**. Using  $3\frac{1}{2} \times \frac{1}{4}$ -inch hex bolts, washers, and nuts, sections may be attached as needed, for a total height of 6, 12 or 18 feet. Drill the holes in two connectors at a time. This ensures good alignment of the holes. A drill press is ideal for this job, but with care a hand drill can be used if necessary.

Line up two mast sections end to end, being careful that they are perfectly straight. Use the predrilled connectors to maintain pole straightness, and drill through the poles, one at a time. If good alignment is maintained, a straight 18-foot mast section can be made. Label the connectors and poles immediately so they are always assembled in the same order.

When assembling the antenna, install all the elements on the boom before attaching the feed line. Connect the coax to the screw connections on the driven-element support plate and run the cable along the strut to the boom. From there, the cable should be routed directly to the mast and down. Assemble the mast sections to the desired height. The antenna provides good performance, and has a reasonable SWR curve over the entire 144-MHz band (**Fig 56**).

## Building Quagi Antennas

The Quagi antenna was designed by [Wayne Overbeck, N6NB](#). He first published information on this antenna in 1977 (see Bibliography). There are a few tricks to Quagi building, but nothing very difficult or complicated is involved. In fact, Overbeck mass produced as many as 16 in one day. **Tables 18** and **19** give the dimensions for Quagis for various frequencies up to 446 MHz.

For the designs of **Tables 18** and **19**, the boom is *wood* or any other nonconductor (such as, fiberglass or Plexiglas).

If a metal boom is used, a new design and new element lengths will be required. Many VHF antenna builders go wrong by failing to follow this rule: If the original uses a metal boom, use the same size and shape metal boom when you duplicate it. If it calls for a wood boom, use a nonconductor. Many amateurs dislike wood booms, but in a salt air environment they outlast aluminum (and surely cost less). Varnish the boom for added protection.

The 144-MHz version is usually built on a 14-foot,  $1 \times 3$ -inch boom, with the boom tapered to 1 inch at both ends. Clear pine is best because of its light weight, but construction grade Douglas fir works well. At 222 MHz the boom is under 10 feet long, and most builders use  $1 \times 2$  or (preferably)  $\frac{3}{4} \times 1\frac{1}{4}$ -inch pine molding stock. At 432 MHz, except for long-boom versions, the boom should be  $\frac{1}{2}$ -inch thick or less. Most builders use strips of  $\frac{1}{2}$ -inch exterior plywood for 432 MHz.

The quad elements are supported at the current maxima (the top and bottom, the latter beside the feed point) with Plexiglas or small strips of wood. See **Fig 57**. The quad elements are made of #12 copper wire, commonly used in house wiring. Some builders may elect to use #10 wire on 144 MHz and #14 on 432 MHz, although this changes the resonant frequency slightly. Solder a type N connector (an SO-239 is often used at 144 MHz) at the midpoint of the driven element bottom side, and close the reflector loop.

**Table 18**

### Dimensions, 8-Element Quagi

Element Lengths	144.5 MHz	147 MHz	222 MHz	432 MHz	446 MHz
Reflector <sup>1</sup>	86 $\frac{5}{8}$ "	85"	56 $\frac{3}{8}$ "	28"	27 $\frac{1}{8}$ "
Driven <sup>2</sup>	82"	80"	53 $\frac{1}{2}$ "	26 $\frac{5}{8}$ "	25 $\frac{7}{8}$ "
Directors	35 $\frac{15}{16}$ " to 35" in $\frac{3}{16}$ " steps	35 $\frac{5}{16}$ " to 34 $\frac{3}{8}$ " in $\frac{3}{16}$ " steps	23 $\frac{3}{8}$ " to 22 $\frac{3}{4}$ " in $\frac{1}{8}$ " steps	11 $\frac{3}{4}$ " to 11 $\frac{7}{16}$ " in $\frac{1}{16}$ " steps	11 $\frac{3}{8}$ " to 11 $\frac{1}{16}$ " in $\frac{1}{16}$ " steps
<b>Spacing</b>					
R-DE	21"	20 $\frac{1}{2}$ "	13 $\frac{5}{8}$ "	7"	6.8"
DE-D1	15 $\frac{3}{4}$ "	15 $\frac{3}{8}$ "	10 $\frac{1}{4}$ "	5 $\frac{1}{4}$ "	5.1"
D1-D2	33"	32 $\frac{1}{2}$ "	21 $\frac{1}{2}$ "	11"	10.7"
D2-D3	17 $\frac{1}{2}$ "	17 $\frac{1}{8}$ "	11 $\frac{3}{8}$ "	5.85"	5.68"
D3-D4	26.1"	25 $\frac{5}{8}$ "	17"	8.73"	8.46"
D4-D5	26.1"	25 $\frac{5}{8}$ "	17"	8.73"	8.46"
D5-D6	26.1"	25 $\frac{5}{8}$ "	17"	8.73"	8.46"
<b>Stacking Distance Between Bays</b>					
	11"	10'10"	7'1 $\frac{1}{2}$ "	3'7"	3'5 $\frac{5}{8}$ "

<sup>1</sup> All #12 TW (electrical) wire, closed loops.

<sup>2</sup> All #12 TW wire loops, fed at bottom.



**Table 19**  
**432-MHz, 15-Element, Long Boom Quagi**  
**Construction Data**

<i>Element Lengths, Inches</i>	<i>Interelement Spacing, Inches</i>
R—28	R-DE7
DE—26 <sup>5</sup> / <sub>8</sub>	DE-D1—5 <sup>1</sup> / <sub>4</sub>
D1—11 <sup>3</sup> / <sub>4</sub>	D1-D2—11
D2—11 <sup>1</sup> / <sub>16</sub>	D2-D3—5 <sup>7</sup> / <sub>8</sub>
D3—11 <sup>5</sup> / <sub>8</sub>	D3-D4—8 <sup>3</sup> / <sub>4</sub>
D4—11 <sup>9</sup> / <sub>16</sub>	D4-D5—8 <sup>3</sup> / <sub>4</sub>
D5—11 <sup>1</sup> / <sub>2</sub>	D5-D6—8 <sup>3</sup> / <sub>4</sub>
D6—11 <sup>7</sup> / <sub>16</sub>	D6-D7—12
D7—11 <sup>3</sup> / <sub>8</sub>	D7-D8—12
D8—11 <sup>5</sup> / <sub>16</sub>	D8-D9—11 <sup>3</sup> / <sub>4</sub>
D9—11 <sup>5</sup> / <sub>16</sub>	D9-D10—11 <sup>1</sup> / <sub>2</sub>
D10—11 <sup>3</sup> / <sub>4</sub>	D10-D11—9 <sup>3</sup> / <sub>16</sub>
D11—11 <sup>3</sup> / <sub>16</sub>	D11-D12—12 <sup>3</sup> / <sub>8</sub>
D12—11 <sup>1</sup> / <sub>8</sub>	D12-D13—13 <sup>3</sup> / <sub>4</sub>
D13—11 <sup>1</sup> / <sub>16</sub>	

Boom: 1 × 2-in. × 12-ft Douglas fir, tapered to <sup>5</sup>/<sub>8</sub> in. at both ends.

Driven element: #12 TW copper wire loop in square configuration, fed at bottom center with type N connector and 52-Ω coax.

Reflector: #12 TW copper wire loop, closed at bottom.

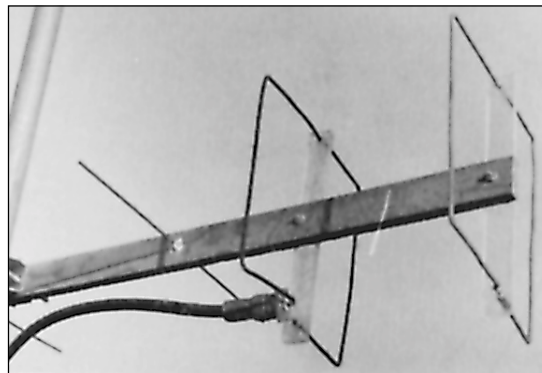
Directors: <sup>1</sup>/<sub>8</sub> in. rod passing through boom.

The directors are mounted through the boom. They can be made of almost any metal rod or wire of about <sup>1</sup>/<sub>8</sub>-inch diameter. Welding rod or aluminum clothesline wire works well if straight. (The designer uses <sup>1</sup>/<sub>8</sub>-inch stainless steel rod obtained from an aircraft surplus store.)

ATV type U bolt mounts the antenna on a mast. A single machine screw, washers and a nut are used to secure the spreaders to the boom so the antenna can be quickly “flattened” for travel. In permanent installations two screws are recommended.

### Construction Reminders

Based on the experiences of Quagi builders, the following hints are offered. First, remember that at 432 MHz



**Fig 57—A close-up view of the feed method used on a 432-MHz Quagi. This arrangement produces a low SWR and gain in excess of 13 dBi with a 4-foot 10-inch boom! The same basic arrangement is used on lower frequencies, but wood may be substituted for the Plexiglas spreaders. The boom is <sup>1</sup>/<sub>2</sub>-inch exterior plywood.**

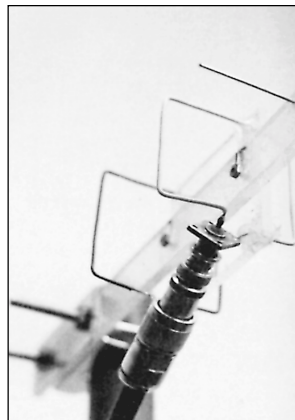
even a <sup>1</sup>/<sub>8</sub>-inch measurement error results in performance deterioration. Cut the loops and elements as carefully as possible. No precision tools are needed, but accuracy is necessary. Also make sure to get the elements in the right order. The longest director goes closest to the driven element.

Finally, remember that a balanced antenna is being fed with an unbalanced line. Every balun the designer tried introduced more trouble in terms of losses than the feed imbalance caused. Some builders have tightly coiled several turns of the feed line near the feed point to limit line radiation. In any case, the feed line should be kept at right angles to the antenna. Run it from the driven element directly to the supporting mast and then up or down perpendicularly for best results.

### QUAGIS FOR 1296 MHz

The Quagi principle has recently been extended to the 1296-MHz band, where good performance is extremely difficult to obtain from homemade conventional Yagis.

**Fig 58** shows the construction and **Table 20** gives the design information for antennas with 10, 15 and 25 elements.



**Fig 58—A view of the 10-element version of the 1296-MHz Quagi. It is mounted on a 30-inch Plexiglas boom with a 3 × 3-inch square of Plexiglas to support the driven element and reflector. Note how the driven element is attached to a standard UG-290 BNC connector. The elements are held in place with silicone sealing compound.**

**Table 20**

**Dimensions, 1296-MHz Quagi Antennas**

Note: All lengths are gross lengths. See text and photos for construction technique and recommended overlap at loop junctions. All loops are made of #18 AWG solid-covered copper bell wire. The Yagi type directors are 1/16-in. brass brazing rod. See text for a discussion of director taper.

**Feed:** Direct with 52-Ω coaxial cable to UG-290 connector at driven element; run coax symmetrically to mast at rear of antenna.

**Boom:** 1/4-in. thick Plexiglas, 30 in. long for 10-element quad or Quagi and 48 in. long for 15-element Quagi; 84 in. for 25-element Quagi.

**10-Element Quagi for 1296 MHz**

Element	Length, Inches	Construction	Element	Interelement Spacing, In.
Reflector	9.5625	Loop	R-DE	2.375
Driven	9.25	Loop	DE-D1	2.0
Director 1	3.91	Brass rod	D1-D2	3.67
Director 2	3.88	Brass rod	D2-D3	1.96
Director 3	3.86	Brass rod	D3-D4	2.92
Director 4	3.83	Brass rod	D4-D5	2.92
Director 5	3.80	Brass rod	D5-D6	2.92
Director 6	3.78	Brass rod	D6-D7	4.75
Director 7	3.75	Brass rod	D7-D8	3.94
Director 8	3.72	Brass rod		

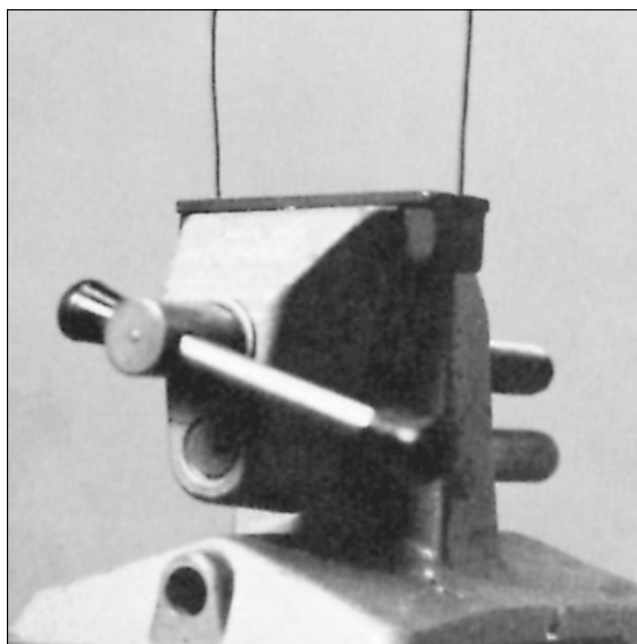
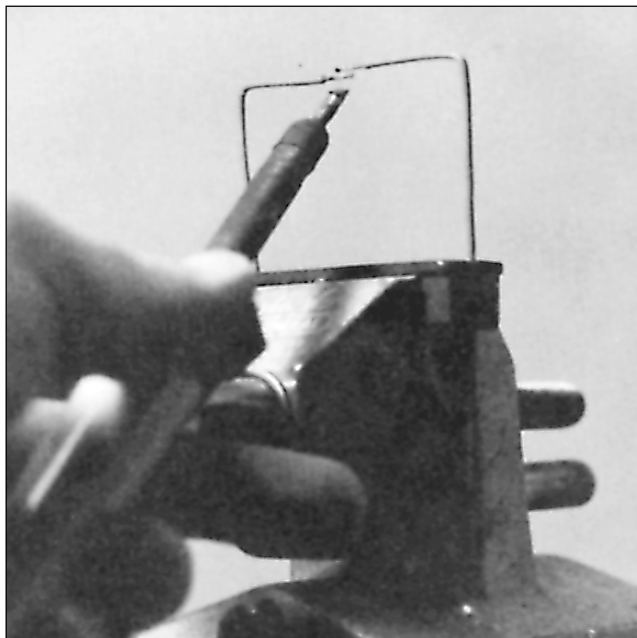
**15-Element Quagi for 1296 MHz**

The first 10 elements are the same lengths as above, but the spacing from D6 to D7 is 4.0 in.; D7 to D8 is also 4.0 in.

Director 9	3.70		D8-D9	3.75
Director 10	3.67		D9-D10	3.83
Director 11	3.64		D10-D11	3.06
Director 12	3.62		D11-D12	4.125
Director 13	3.59		D12-D13	4.58

**25-Element Quagi for 1296 MHz**

The first 15 elements use the same element lengths and spacings as the 15-element model. The additional directors are evenly spaced at 3.0-in. intervals and taper in length successively by 0.02 in. per element. Thus, D23 is 3.39 in.



**Fig 59**—These photos show the construction method used for the 1296-MHz quad type parasitic elements. The two ends of the #18 bell wire are brought together with an overlap of 1/8 inch and soldered.

At 1296 MHz, even slight variations in design or building materials can cause substantial changes in performance. The 1296-MHz antennas described here work every time—but only if the same materials are used and the antennas are built *exactly* as described. This is not to discourage experimentation, but if modifications to these 1296-MHz antenna designs are contemplated, consider building one antenna as described here, so a reference is available against which variations can be compared.

The Quagis (and the cubical quad) are built on 1/4-inch thick Plexiglas booms. The driven element and reflector (and also the directors in the case of the cubical quad) are made of insulated #18 AWG solid copper bell wire, available at hardware and electrical supply stores. Other types and sizes

of wire work equally well, but the dimensions vary with the wire diameter. Even removing the insulation usually necessitates changing the loop lengths.

Quad loops are approximately square (**Fig 59**), although the shape is relatively noncritical. The element lengths, however, *are* critical. At 1296 MHz, variations of 1/16 inch alter the performance measurably, and a 1/8-inch departure can cost several decibels of gain. The loop lengths given are *gross* lengths. Cut the wire to these lengths and then solder the two ends together. There is a 1/8-inch overlap

where the two ends of the reflector (and director) loops are joined, as shown in Fig 59.

The driven element is the most important of all. The #18 wire loop is soldered to a standard UG-290 chassis-mount BNC connector as shown in the photographs. This exact type of connector must be used to ensure uniformity in construction. Any substitution may alter the driven element electrical length. One end of the 9¼-inch driven

loop is pushed as far as it can go into the center pin, and is soldered in that position. The loop is then shaped and threaded through small holes drilled in the Plexiglas support. Finally, the other end is fed into one of the four mounting holes on the BNC connector and soldered. In most cases, the best SWR is obtained if the end of the wire just passes through the hole so it is flush with the opposite side of the connector flange.

## Loop Yagis for 1296 MHz

Described here are loop Yagis for the 1296-MHz band. The loop Yagi fits into the quad family of antennas, as each element is a closed loop with a length of approximately 1 λ. Several versions are described, so the builder can choose the boom length and frequency coverage desired for the task at hand. Mike Walters, G3JVL, brought the original loop Yagi design to the amateur community in the 1970s. Since then, many versions have been developed with different loop and boom dimensions. Chip Angle, N6CA, developed the antennas shown here.

Three sets of dimensions are given. Good performance can be expected if the dimensions are carefully followed. Check all dimensions before cutting or drilling anything. The 1296-MHz version is intended for weak-signal operation, while the 1270-MHz version is optimized for FM and mode L satellite work. The 1283-MHz antenna provides acceptable performance from 1280 to 1300 MHz.

These antennas have been built on 6 and 12-foot booms. Results of gain tests at VHF conferences and by individuals around the country show the gain of the 6-foot model to be

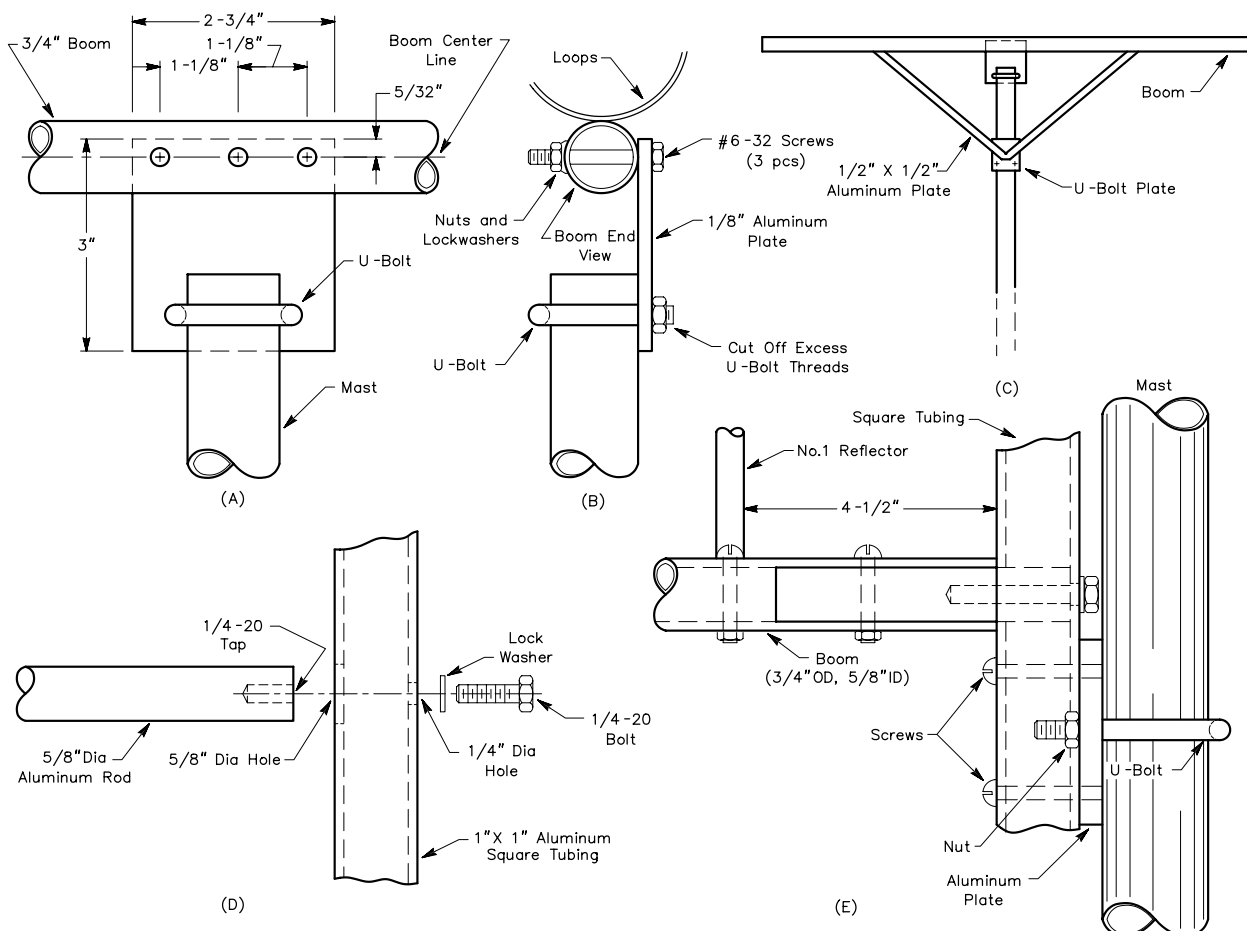


Fig 60—Loop Yagi boom-to-mast plate details are given at A. At B, the mounting of the antenna to the mast is detailed. A boom support for long antennas is shown at C. The arrangement shown in D and E may be used to rear-mount antennas up to 6 or 7 feet long.

about 18 dBi, while the 12-foot version provides about 20.5 dBi. Swept measurements indicate that gain is about 2 dB down from maximum gain at  $\pm 30$  MHz from the design frequency. The SWR, however, deteriorates within a few megahertz on the low side of the design center frequency.

### The Boom

The dimensions given here apply only to a  $3/4$ -inch OD boom. If a different boom size is used, the dimensions must be scaled accordingly. Many hardware stores carry aluminum tubing in 6 and 8-foot lengths, and that tubing is suitable for a short Yagi. If a 12-foot antenna is planned, find a piece of more rugged boom material, such as 6061-T6 grade aluminum. Do not use anodized tubing. The 12-foot antenna must have additional boom support to minimize boom sag. The 6-foot version can be rear mounted. For rear mounting, allow  $4\frac{1}{2}$  inches of boom behind the last reflector to eliminate SWR effects from the support.

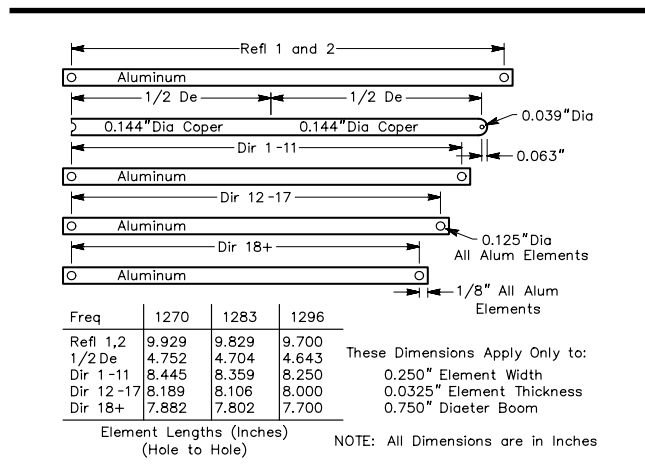
The antenna is attached to the mast with a gusset plate. This plate mounts at the boom center. See Fig 60. Drill the plate mounting holes perpendicular to the element mounting holes (assuming the antenna polarization is to be horizontal).

Elements are mounted to the boom with #4-40 machine screws, so a series of #33 (0.113-inch) holes must be drilled along the center of the boom to accommodate this hardware. Fig 61 shows the element spacings for different parts of the band. Dimensions should be followed as closely as possible.

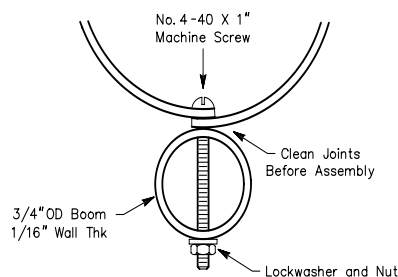
### Parasitic Elements

The reflectors and directors are cut from 0.032-inch thick aluminum sheet and are  $1/4$  inch wide. Fig 62 indicates the lengths for the various elements. These lengths apply only to elements cut from the specified material. For best results, the element strips should be cut with a shear. If the edges are left sharp, birds won't sit on the elements.

Drill the mounting holes as shown in Fig 62 after carefully marking their locations. After the holes are drilled, form each strap into a circle. This is easily done by wrapping the element around a round form. (A small juice can works well.)

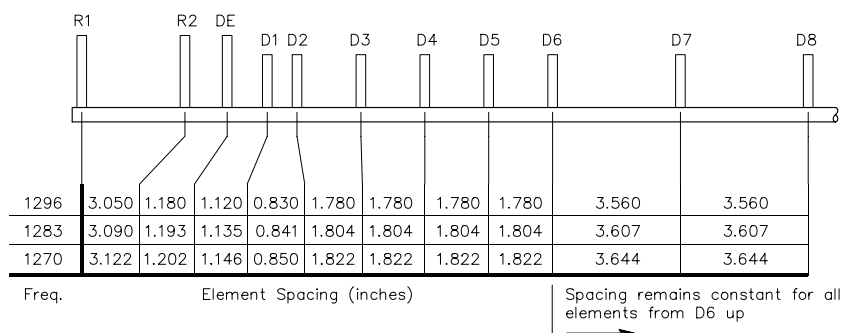


**Fig 62—Parasitic elements for the loop Yagi are made from aluminum sheet, the driven element from copper sheet. The dimensions given are for  $1/4$ -inch wide by 0.0325-inch thick elements only. Lengths specified are hole to hole distances; the holes are located  $1/8$  inch from each element end.**



**Fig 63—Element-to-boom mounting details.**

Mount the loops to the boom with #4-40  $\times$  1-inch machine screws, lock washers and nuts. See Fig 63. It is best to use only stainless steel or plated brass hardware. Although the initial cost is higher than for ordinary plated steel hardware, stainless or brass hardware will not rust and need



**Fig 61—Boom drilling dimensions. These dimensions must be carefully followed and the same materials used if performance is to be optimum. Element spacings are the same for all directors after D6—use as many as necessary to fill the boom.**

replacement after a few years. Unless the antenna is painted, the hardware will definitely deteriorate.

### Driven Element

The driven element is cut from 0.032-inch copper sheet and is  $\frac{1}{4}$  inch wide. Drill three holes in the strap as detailed in Fig 62. Trim the ends as shown and form the strap into a loop similar to the other elements. This antenna is like a quad; if the loop is fed at the top or bottom, it is horizontally polarized.

Driven element mounting details are shown in Fig 64. A mounting fixture is made from a  $\frac{1}{4}$ -20  $\times$   $1\frac{1}{4}$ -inch brass bolt. File the bolt head to a thickness of  $\frac{1}{8}$  inch. Bore a 0.144-inch (#27 drill) hole lengthwise through the center of the bolt. A piece of 0.141-inch semi-rigid Hardline (UT-141 or equivalent) mounts through this hole and is soldered to the driven loop feed point. The point at which the UT-141 passes through the copper loop and brass mounting fixture should be left unsoldered at this time to allow for matching adjustments when the antenna is completed, although the range of adjustment is not very large.

The UT-141 can be any convenient length. Attach the connector of your choice (preferably type N). Use a short piece of low-loss RG-8 size cable (or  $\frac{1}{2}$ -inch Hardline) for the run down the boom and mast to the main feed line. For best results, the main feed line should be the lowest loss 50- $\Omega$  cable obtainable. Good  $\frac{7}{8}$ -inch Hardline has 1.5 dB of loss per 100 feet and virtually eliminates the need for remote mounting of the transmit converter or amplifier.

### Tuning the Driven Element

If the antenna is built carefully to the dimensions given, the SWR should be close to 1:1. Just to be sure, check the SWR if you have access to test equipment. Be sure the signal source is clean, however; wattmeters respond to “dirty” signals and can give erroneous readings. If problems are encountered, recheck all dimensions. If they look good, a minor improvement may be realized by changing the shape of the driven element. Slight bending of reflector 2 may also improve the SWR. When the desired match has been obtained, solder the point where the UT-141 jacket passes through the loop and brass bolt.

### Tips for 1296-MHz Antenna Installations

Construction practices that are common on lower

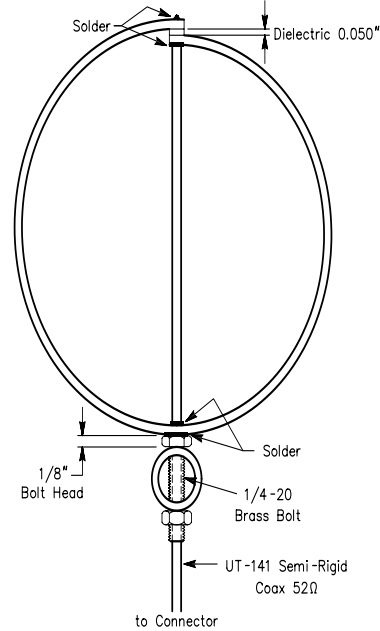


Fig 64—Driven element details. See Fig 62 and the text for additional information.

frequencies cannot be used on 1296 MHz. This is the most important reason why all who venture to these frequencies are not equally successful. First, when a proven design is used, copy it exactly—don’t change *anything*. This is especially true for antennas.

Use the best feed line you can get. Here are some realistic measurements of common coaxial cables at 1296 MHz (loss per 100 feet).

RG-8, 213, 214: 11 dB

$\frac{1}{2}$ -inch foam/copper Hardline: 4 dB

$\frac{7}{8}$ -inch foam/copper Hardline: 1.5 dB

Mount the antennas to keep feed-line losses to an absolute minimum. Antenna height is less important than keeping the line losses low. *Do not* allow the mast to pass through the elements, as is common on antennas for lower frequencies. Cut all U bolts to the minimum length needed;  $\frac{1}{4} \lambda$  at 1296 MHz is only a little over 2 inches. Avoid any unnecessary metal around the antenna.

# Trough Reflectors for 432 and 1296 MHz

Dimensions are given in Fig 65 for 432 and 1296-MHz trough reflectors. The gain to be expected is 15 dB and 17 dB, respectively. A very convenient arrangement, especially for portable work, is to use a metal hinge at each angle of the reflector. This permits the reflector to be folded flat for transit. It also permits experiments to be carried out with different apex angles.

A housing is required at the dipole center to prevent the entry of moisture and, in the case of the 432-MHz antenna, to support the dipole elements. The dipole may be moved in and out of the reflector to get either minimum SWR or, if this cannot be measured, maximum gain. If a two-stub tuner or other matching device is used, the dipole may be placed to give optimum gain and the matching

device adjusted to give optimum match. In the case of the 1296-MHz antenna, the dipole length can be adjusted by means of the brass screws at the ends of the elements. Locking nuts are essential.

The reflector should be made of sheet aluminum for 1296 MHz, but can be constructed of wire mesh (with twists parallel to the dipole) for 432 MHz. To increase the gain by 3 dB, a pair of these arrays can be stacked so the reflectors are barely separated (to prevent the formation of a slot radiator by the edges). The radiating dipoles must then be fed in phase, and suitable feeding and matching must be arranged. A two-stub tuner can be used for matching either a single or double-reflector system.

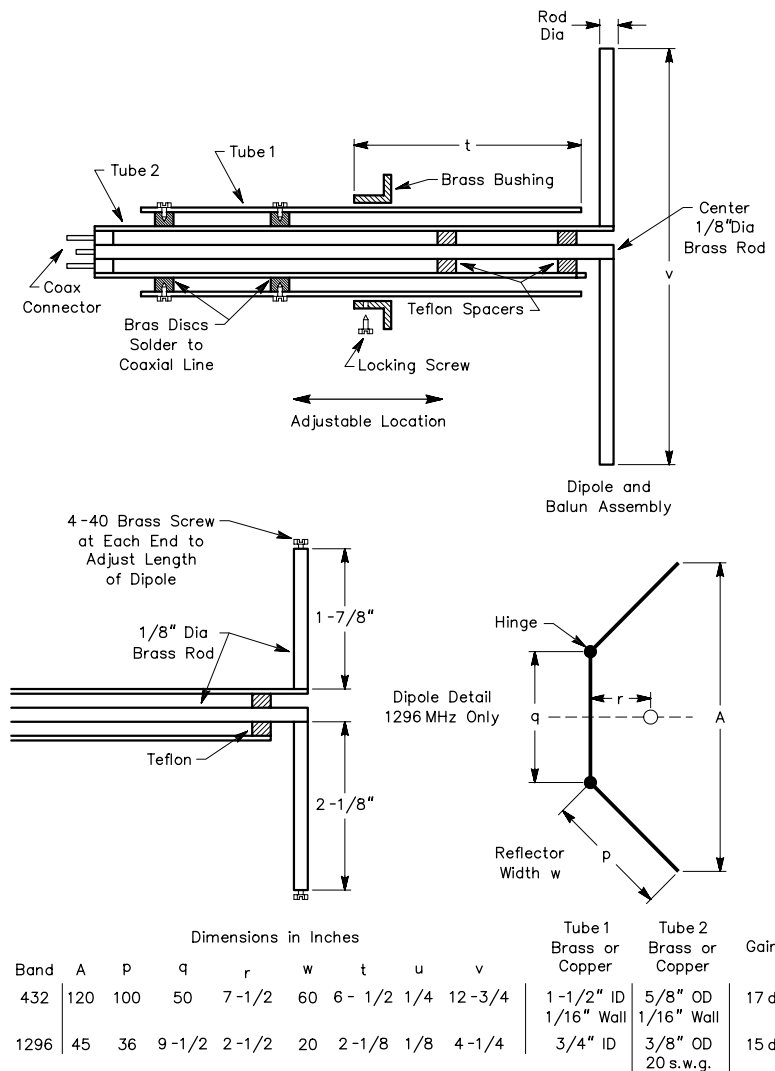


Fig 65—Practical construction information for trough reflector antennas for 432 and 1296 MHz.

# A Horn Antenna for 10 GHz

The horn antenna is the easiest antenna for the beginner on 10 GHz to construct. It can be made out of readily available flat sheet brass. Because it is inherently a broadband structure, minor constructional errors can be tolerated. The one drawback is that horn antennas become physically cumbersome at gains over about 25 dB, but for most line-of-sight work this much gain is rarely necessary. This antenna was designed by Bob Atkins, KA1GT, and appeared in *QST* for April and May 1987.

Horn antennas are usually fed by waveguide. When operating in its normal frequency range, waveguide propagation is in the  $TE_{10}$  mode. This means that the electric (E) field is across the short dimension of the guide and the magnetic (H) field is across the wide dimension. This is the reason for the E plane and H-plane terminology shown in Fig 66.

There are many varieties of horn antennas. If the waveguide is flared out only in the H-plane, the horn is called an H-plane sectoral horn. Similarly, if the flare is only in the E-plane, an E-plane sectoral horn results. If the flare is in both planes, the antenna is called a pyramidal horn.

For a horn of any given aperture, directivity (gain along the axis) is maximum when the field distribution across the aperture is uniform in magnitude and phase. When the fields are not uniform, side lobes that reduce the directivity of the antenna are formed. To obtain a uniform distribution, the horn should be as long as possible with minimum flare angle. From a practical point of view, however, the horn should be as short as possible, so there is an obvious conflict between performance and convenience.

Fig 67 illustrates this problem. For a given flare angle and a given side length, there is a path-length difference from the apex of the horn to the center of the aperture ( $L$ ), and from the apex of the horn to the edge of the aperture ( $L'$ ). This causes a phase difference in the field across the aperture, which in turn causes formation of side lobes, degrading directivity (gain along the axis) of the antenna. If  $L$  is large this difference is small, and the field is almost uniform. As  $L$  decreases, however, the phase difference increases and directivity suffers. An optimum (shortest possible) horn is constructed so that this phase difference is the maximum allowable before side lobes become excessive and axial gain markedly decreases.

The magnitude of this permissible phase difference is different for E and H-plane horns. For the E-plane horn, the field intensity is quite constant across the aperture. For the H-plane horn, the field tapers to zero at the edge. Consequently, the phase difference at the edge of the aperture in the E-plane horn is more critical and should be held to less than  $90^\circ$  ( $1/4 \lambda$ ). In an H-plane horn, the allowable phase difference is  $144^\circ$  ( $0.4 \lambda$ ). If the aperture of a pyramidal horn exceeds one wavelength in both planes, the E and H-plane patterns are essentially independent and can be analyzed separately.

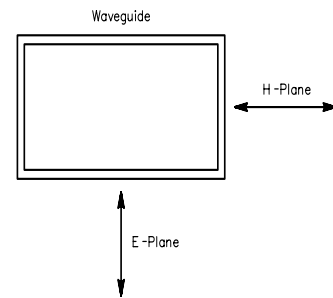


Fig 66—10-GHz antennas are usually fed with waveguide. See text for a discussion of waveguide propagation characteristics.

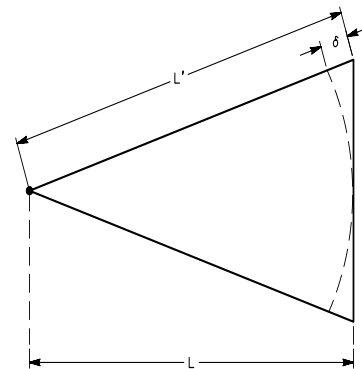


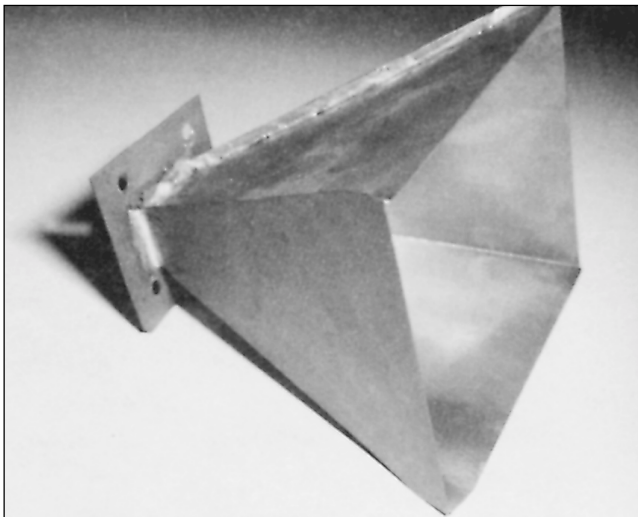
Fig 67—The path-length (phase) difference between the center and edge of a horn antenna is  $\Delta$ .

The usual direction for orienting the waveguide feed is with the broad face horizontal, giving vertical polarization. If this is the case, the H-plane sectoral horn has a narrow horizontal beamwidth and a very wide vertical beamwidth. This is not a very useful beam pattern for most amateur applications. The E-plane sectoral horn has a narrow vertical beamwidth and a wide horizontal beamwidth. Such a radiation pattern could be useful in a beacon system where wide coverage is desired.

The most useful form of the horn for general applications is the optimum pyramidal horn. In this configuration the two beamwidths are almost the same. The E-plane (vertical) beamwidth is slightly less than the H-plane (horizontal), and also has greater side lobe intensity.

## Building the Antenna

A 10-GHz pyramidal horn with 18.5 dBi gain is shown in Fig 68. The first design parameter is usually the required gain, or the maximum antenna size. These are of course



**Fig 68**—This pyramidal horn has 18.5 dBi gain at 10 GHz. Construction details are given in the text.

related, and the relationships can be approximated by the following:

$$L = \text{H-plane length } (\lambda) = 0.0654 \times \text{gain} \quad (\text{Eq 1})$$

$$A = \text{H-plane aperture } (\lambda) = 0.0443 \times \text{gain} \quad (\text{Eq 2})$$

$$B = \text{E-plane aperture } (\lambda) = 0.81 A \quad (\text{Eq 3})$$

where

gain is expressed as a *ratio*; 20 dB gain = 100

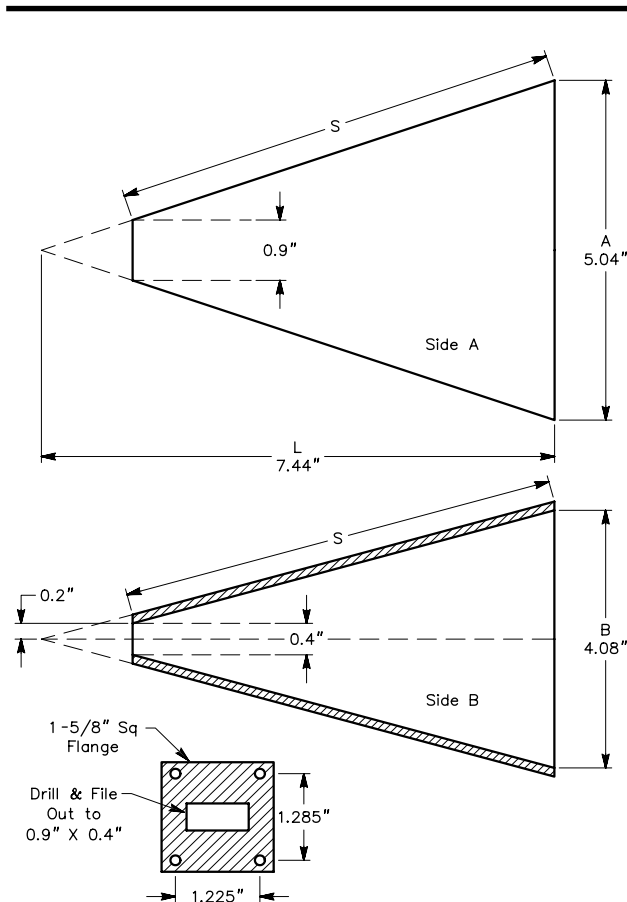
L, A and B are dimensions shown in **Fig 69**

From these equations, the dimensions for a 20-dB gain horn for 10.368 GHz can be determined. One wavelength at 10.368 GHz is 1.138 inches. The length (L) of such a horn is  $0.0654 \times 100 = 6.54 \lambda$ . At 10.368 GHz, this is 7.44 inches. The corresponding H-plane aperture (A) is  $4.43 \lambda$  (5.04 inches), and the E-plane aperture (B), 4.08 inches.

The easiest way to make such a horn is to cut pieces from brass sheet stock and solder them together. Fig 69 shows the dimensions of the triangular pieces for the sides and a square piece for the waveguide flange. (A standard commercial waveguide flange could also be used.) Because the E plane and H-plane apertures are different, the horn opening is not square. Sheet thickness is unimportant; 0.02 to 0.03 inch works well. Brass sheet is often available from hardware or hobby shops.

Note that the triangular pieces are trimmed at the apex to fit the waveguide aperture (0.9 × 0.4 inch). This necessitates that the length, from base to apex, of the smaller triangle (side B) is shorter than that of the larger (side A). Note that the length, S, of the two different sides of the horn must be the same if the horn is to fit together! For such a simple looking object, getting the parts to fit together properly requires careful fabrication.

The dimensions of the sides can be calculated with



**Fig 69**—Dimensions of the brass pieces used to make the 10-GHz horn antenna. Construction requires two of each of the triangular pieces (side A and side B).

simple geometry, but it is easier to draw out templates on a sheet of cardboard first. The templates can be used to build a mock antenna to make sure everything fits together properly before cutting the sheet brass.

First, mark out the larger triangle (side A) on cardboard. Determine at what point its width is 0.9 inch and draw a line parallel to the base as shown in Fig 69. Measure the length of the side S; this is also the length of the sides of the smaller (side B) pieces.

Mark out the shape of the smaller pieces by first drawing a line of length B and then constructing a second line of length S. One end of line S is an end of line B, and the other is 0.2 inch above a line perpendicular to the center of line B as shown in Fig 69. (This procedure is much more easily followed than described.) These smaller pieces are made slightly oversize (shaded area in Fig 69) so you can construct the horn with solder seams on the outside of the horn during assembly.

Cut out two cardboard pieces for side A and two for side B and tape them together in the shape of the horn. The aperture at the waveguide end should measure 0.9 × 0.4



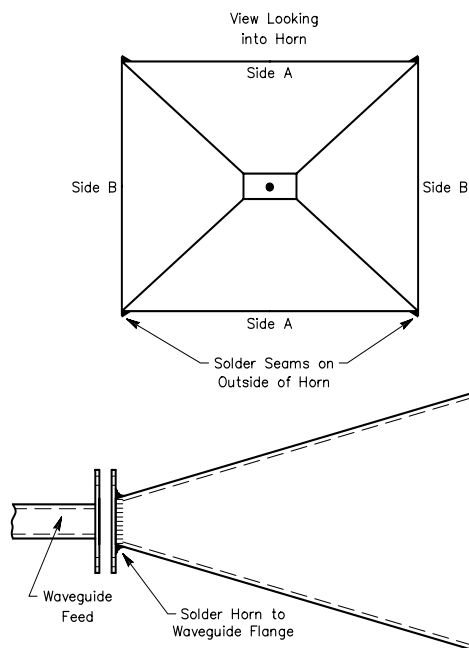


Fig 70—Assembly of the 10-GHz horn antenna.

inch and the aperture at the other end should measure  $5.04 \times 4.08$  inches.

If these dimensions are correct, use the cardboard templates to mark out pieces of brass sheet. The brass sheet should be cut with a bench shear if one is available, because scissors type shears tend to bend the metal. Jig the pieces together and solder them on the *outside* of the seams. It is important to keep both solder and rosin from contaminating the inside of the horn; they can absorb RF and reduce gain at these frequencies.

Assembly is shown in Fig 70. When the horn is completed, it can be soldered to a standard waveguide flange, or one cut out of sheet metal as shown in Fig 69. The transition between the flange and the horn must be smooth. This antenna provides an excellent performance-to-cost ratio (about 20 dB gain for about \$5 in parts).

## Periscope Antenna Systems

One problem common to all who use microwaves is that of mounting an antenna at the maximum possible height while trying to minimize feed-line losses. The higher the frequency, the more severe this problem becomes, as feeder losses increase with frequency. Because parabolic dish reflectors are most often used on the higher bands, there is also the difficulty of waterproofing feeds (particularly waveguide feeds). Inaccessibility of the dish is also a problem when changing bands. Unless the tower is climbed every time and the feed changed, there must be a feed for each band mounted on the dish. One way around these problems is to use a periscope antenna system (sometimes called a “flyswatter antenna”).

The material in this section was prepared by Bob Atkins, KA1GT, and appeared in *QST* for January and February 1984. Fig 71 shows a schematic representation of a periscope antenna system. A plane reflector is mounted at the top of a rotating tower at an angle of  $45^\circ$ . This reflector can be elliptical with a major-to-minor axis ratio of 1.41, or rectangular. At the base of the tower is mounted a dish or other type of antenna such as a Yagi, pointing straight up. The advantage of such a system is that the feed antenna can be changed and worked on easily. Additionally, with a correct choice of reflector size, dish size, and dish-to-reflector spacing, feed losses can be made small, increasing the effective system gain. In fact, for some particular system configurations, the gain of the overall system can be greater than that of the feed antenna alone.

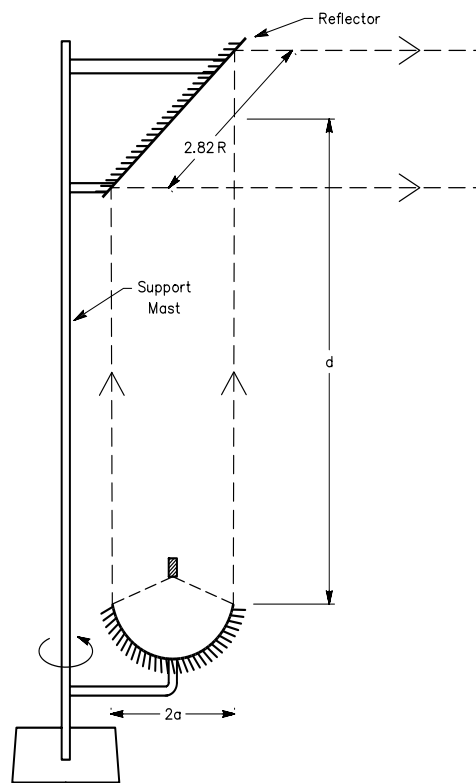


Fig 71—The basic periscope antenna. This design makes it easy to adjust the feed antenna.

## Gain of a Periscope System

Fig 72 shows the relationship between the effective gain of the antenna system and the distance between the reflector and feed antenna for an elliptical reflector. At first sight, it is not at all obvious how the antenna system can have a higher gain than the feed alone. The reason lies in the fact that, depending on the feed-to-reflector spacing, the reflector may be in the near field (Fresnel) region of the antenna, the far field (Fraunhofer) region, or the transition region between the two.

In the far field region, the gain is proportional to the reflector area and inversely proportional to the distance between the feed and reflector. In the near field region, seemingly strange things can happen, such as decreasing gain with decreasing feed-to-reflector separation. The reason for this gain decrease is that, although the reflector is intercepting more of the energy radiated by the feed, it does not all contribute in phase at a distant point, and so the gain decreases.

In practice, rectangular reflectors are more common than elliptical. A rectangular reflector with sides equal in length to the major and minor axes of the ellipse will, in fact, normally give a slight gain increase. In the far field region, the gain will be proportional to the area of the reflector. To use Fig 72 with a rectangular reflector,  $R^2$  may be replaced by  $A/\pi$ , where  $A$  is the projected area of the reflector. The antenna pattern depends in a complicated way on the system parameters (spacing and size of the elements),

but Table 21 gives an approximation of what to expect.  $R$  is the radius of the projected circular area of the elliptical reflector (equal to the minor axis radius), and  $b$  is the length of the side of the projected square area of the rectangular reflector (equal to the length of the short side of the rectangle).

For those wishing a rigorous mathematical analysis of this type of antenna system, several references are given in the Bibliography at the end of this chapter.

## Mechanical Considerations

There are some problems with the physical construction of a periscope antenna system. Since the antenna gain of a microwave system is high and, hence, its beamwidth narrow, the reflector must be accurately aligned. If the reflector does not produce a beam that is horizontal, the useful gain of the system will be reduced. From the geometry of the system, an angular misalignment of the reflector of  $X$  degrees in the vertical plane will result in an angular misalignment of  $2X$  degrees in the vertical alignment of the antenna system pattern. Thus, for a dish pointing straight up (the usual case), the reflector must be at an angle of  $45^\circ$  to the vertical and should not fluctuate from factors such as wind loading.

The reflector itself should be flat to better than  $1/10 \lambda$  for the frequency in use. It may be made of mesh, provided that the holes in the mesh are also less than  $1/10 \lambda$  in diameter. A second problem is getting the support mast to rotate about a truly vertical axis. If the mast is not vertical, the resulting

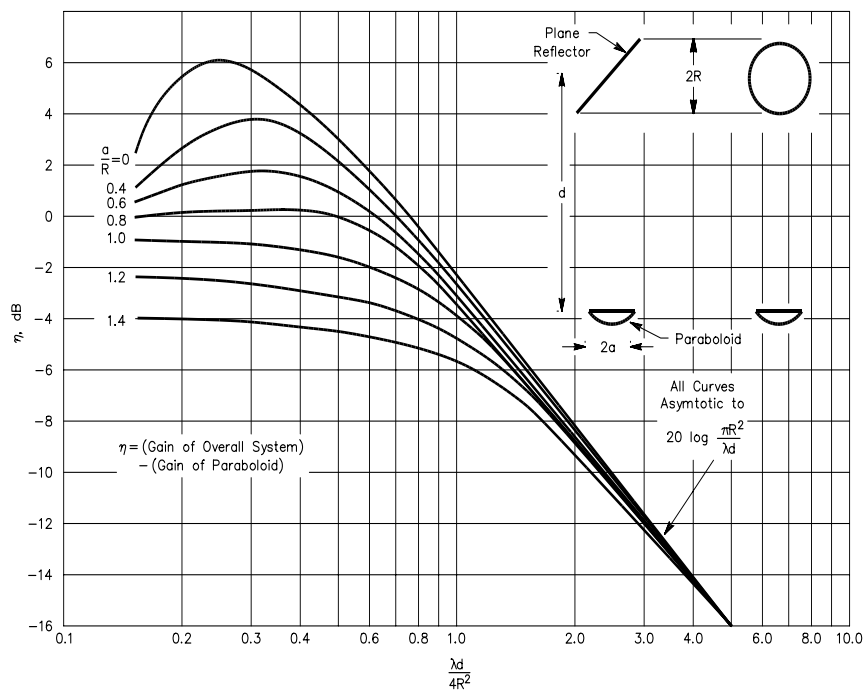


Fig 72—Gain of a periscope antenna using a plane elliptical reflector (after Jasik—see Bibliography).

**Table 21****Radiation Patterns of Periscope Antenna Systems**

	<i>Elliptical Reflector</i>	<i>Rectangular Reflector</i>
3-dB beamwidth, degrees	60 $\lambda/2R$	52 $\lambda/b$
6-dB beamwidth, degrees	82 $\lambda/2R$	68 $\lambda/b$
First minimum, degrees from axis	73 $\lambda/2R$	58 $\lambda/b$
First maximum, degrees from axis	95 $\lambda/2R$	84 $\lambda/b$
Second minimum, degrees from axis	130 $\lambda/2R$	116 $\lambda/b$
Second maximum, degrees from axis	156 $\lambda/2R$	142 $\lambda/b$
Third minimum, degrees from axis	185 $\lambda/2R$	174 $\lambda/b$

beam will swing up and down from the horizontal as the system is rotated, and the effective gain at the horizon will fluctuate. Despite these problems, amateurs have used periscope antennas successfully on the bands through 10 GHz. Periscope antennas are used frequently in commercial service, though usually for point-to-point transmission. Such a commercial system is shown in **Fig 73**.

Circular polarization is not often used for terrestrial work, but if it is used with a periscope system there is an important point to remember. The circularity sense changes when the signal is reflected. Thus, for right hand circularity with a periscope antenna system, the feed arrangement on the ground should produce left hand circularity. It should also be mentioned that it is possible (though more difficult for amateurs) to construct a periscope antenna system using a parabolically curved reflector. The antenna system can then be regarded as an offset fed parabola. More gain is available from such a system at the added complexity of constructing a parabolically curved reflector, accurate to  $1/10 \lambda$ .

**BIBLIOGRAPHY**

Source material and more extended discussion of topics covered in this chapter can be found in the references given below and in the textbooks listed at the end of **Chapter 2**.

B. Atkins, "Periscope Antenna Systems," *The New Frontier, QST*, Jan and Feb 1984.  
 B. Atkins, "Horn Antennas for 10 GHz," *The New Frontier, QST*, Apr and May 1987.  
 J. Drexler, "An Experimental Study of a Microwave Periscope," *Proc. IRE, Correspondence*, Vol 42, Jun 1954, p 1022.  
 D. Evans and G. Jessop, *VHF-UHF Manual*, 3rd ed. (London: RSGB), 1976.  
 N. Foot, "WA9HUV 12-foot Dish for 432 and 1296 MHz," *The World Above 50 Mc.*, *QST*, Jun 1971, pp 98-101, 107.  
 N. Foot, "Cylindrical Feed Horn for Parabolic Reflectors," *Ham Radio*, May 1976.



**Fig 73—**  
**Commercial periscope antennas, such as this one, are often used for point-to-point communication.**

G. Gobau, "Single-Conductor Surface-Wave Transmission Lines," *Proc. IRE*, Vol 39, Jun 1951, pp 619-624; also see *Journal of Applied Physics*, Vol 21 (1950), pp 1119-1128.  
 R. E. Greenquist and A. J. Orlando, "An Analysis of Passive Reflector Antenna Systems," *Proc. IRE*, Vol 42, Jul 1954, pp 1173-1178.  
 G. A. Hatherell, "Putting the G Line to Work," *QST*, Jun 1974, pp 11-15, 152, 154, 156.  
 D. L. Hilliard, "A 902-MHz Loop Yagi Antenna," *QST*, Nov 1985, pp 30-32.  
 W. C. Jakes, Jr., "A Theoretical Study of an Antenna-Reflector Problem," *Proc. IRE*, Vol 41, Feb 1953, pp 272-274.  
 H. Jasik, *Antenna Engineering Handbook*, 1st ed. (New York: McGraw-Hill, 1961).  
 R. T. Knadle, "UHF Antenna Ratiometry," *QST*, Feb 1976, pp 22-25.  
 T. Moreno, *Microwave Transmission Design Data* (New York: McGraw-Hill, 1948).  
 W. Overbeck, "The VHF Quagi," *QST*, Apr 1977, pp 11-14.  
 W. Overbeck, "The Long-Boom Quagi," *QST*, Feb 1978, pp 20-21.  
 W. Overbeck, "Reproducible Quagi Antennas for 1296 MHz," *QST*, Aug 1981, pp 11-15.  
 G. Southworth, *Principles and Applications of Waveguide Transmission* (New York: D. Van Nostrand Co, 1950).  
 P. P. Viezbicke, "Yagi Antenna Design," *NBS Technical Note 688* (U. S. Dept. of Commerce/National Bureau of Standards, Boulder, CO), Dec 1976.  
 D. Vilardi, "Easily Constructed Antennas for 1296 MHz," *QST*, Jun 1969.  
 D. Vilardi, "Simple and Efficient Feed for Parabolic Antennas," *QST*, Mar 1973.  
*Radio Communication Handbook*, 5th ed. (London: RSGB, 1976).

# Antenna Systems for Space Communications

There are two basic modes of space communications: satellite and earth-moon-earth (EME—also referred to as moonbounce). Both require consideration of the effects of polarization and elevation angle, along with the azimuth directions of transmitted and received signals.

Signal polarization is generally of little concern on the HF bands, as the original polarization direction is lost after the signal passes through the ionosphere. Vertical antennas receive sky-wave signals emanating from horizontal antennas, and vice versa. It is not beneficial to provide a means of varying the elevation angle in this case, because at HF the takeoff angle is not significantly affected. With satellite communications, however, because

of polarization changes, a signal that would disappear into the noise on one antenna may be S9 on one that is not sensitive to polarization direction. Elevation angle is also important from the standpoint of tracking and avoiding indiscriminate ground reflections that may cause nulls in signal strength.

These are the characteristics common to both satellite and EME communications. There are also characteristics unique to each mode, and these cause the antenna requirements to differ in several ways—some subtle, others profound. Each mode is dealt with separately in this chapter after some basic information pertaining to all space communications is presented.

## Antenna Positioning

Where high-gain antennas are required in space communications, precise and accurate azimuth and elevation control and indication are necessary. High gain implies narrow beamwidth in at least one plane. Low orbit satellites such as FO-12 move through the window very quickly, so azimuth and elevation tracking are essential if high gain antennas are used.

These satellites are fairly easy to access with moderate power and broad coverage antennas. The low power, high-gain approach is more sophisticated, but the high power, low-gain solution may be more practical and economical.

Some EME arrays are fixed, but these are limited to narrow time windows for communication. The az-el positioning systems described in the following sections are adaptable to either satellite or modest EME arrays. **Figs 1** and **2** illustrate one of the more ambitious ventures in positioning a large EME array.

### AN AZ-EL MOUNT FOR CROSSED YAGIS

The mounting system of **Figs 3, 4** and **5** was originally described by **Katashi Nose, KH6IJ**, in June 1973 *QST*. (See the Bibliography at the end of this chapter.) The basic criteria

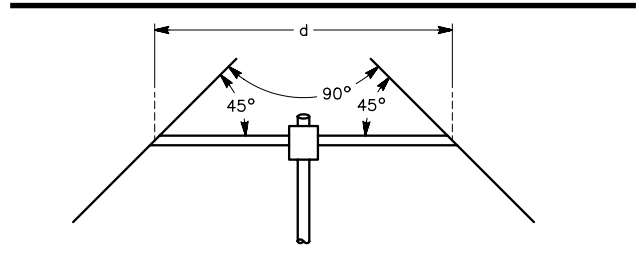
in the design of this system were low cost and ease of assembly. The choice of a crossed Yagi system was influenced by the ready availability of Yagi antennas from dealers. Methods of feeding such arrays are discussed later in this chapter.

**Fig 1—An aggressive approach to steering a giant EME antenna—a 5-inch gun turret from a destroyer.**

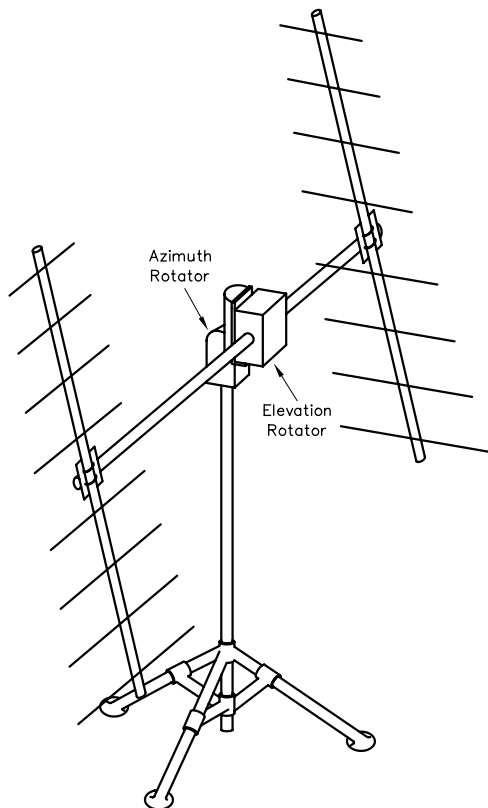




**Fig 2**—The gun mount of Fig 1 with its “warhead” attached—a home-made 42-foot parabolic dish. This is part of the arsenal of Ken Kucera, KA0Y.

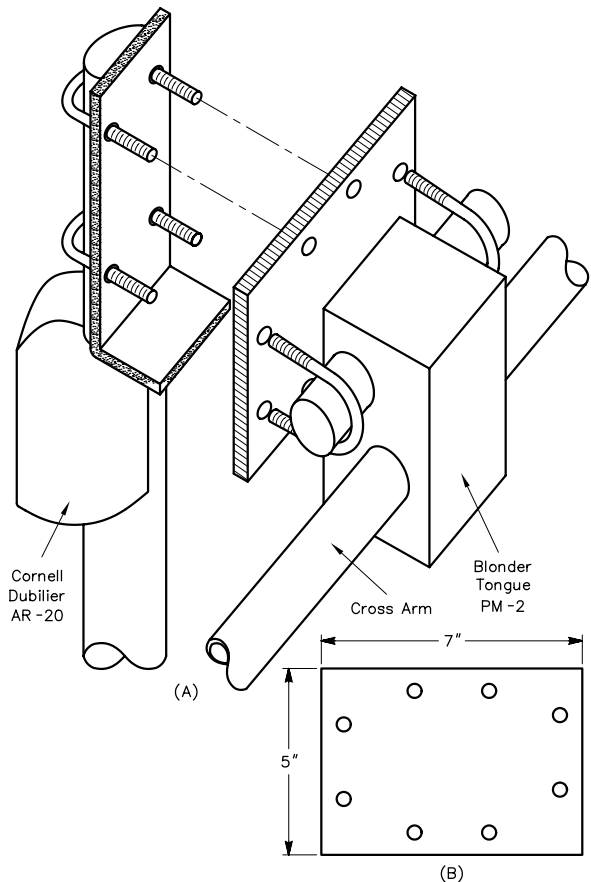


**Fig 4**—An end-on view of the crossed Yagi antennas shows that they are mounted at 90° to each other, and at 45° to the cross boom.



**Fig 3**—A crossed Yagi antenna system can be assembled using off-the-shelf components such as Hy-Gain Yagis, Cornell-Dubilier or Blonder-Tongue rotators and a commercially made tripod.

Fig 3 shows the assembled array. The antennas are eight-element Yagis. Fig 4 is a head-on view of the array, showing the antennas mounted at 90° with respect to each other and 45° with respect to the cross arm. Coupling between the two Yagis is minimal at 90°. By setting the



**Fig 5**—The method of mounting two rotators together. A pair of PM-2 rotators may also be used. The adapter plate (B) may be fabricated from 1/4-inch thick aluminum stock, or a ready made plate is available from Blonder-Tongue.

angle at 45° with respect to the cross arm, coupling is reduced (but not eliminated).

Determine length  $d$  in Fig 4 by pointing the array straight up and rotating it. Length  $d$  should be the minimum distance necessary for the elements to clear the tripod base when this is done. In the array shown in Fig 3, a 5-foot section of TV mast serves the purpose.

## The Mounting Tripod

A mounting tripod can be made of aluminum railing, called “NuRail,” of which all manner of swivels, crosses and T fittings are available. The least expensive method, however, is to purchase a TV-antenna tripod. These tripods sell for such low prices that there is little point in constructing your own. Spread the legs of the tripod more than usual to assure greater support, and be sure that the elements of the antenna clear the base in the straight-up position.

### Elevation and Azimuth Rotators

Any medium-duty rotator can be used for azimuth rotation in this system. The elevation rotator should be one that allows the cross arm of the array to be rotated on its axis when supported at the center.

Fig 5 shows the mounting of the two rotators. The flat portion of the Cornell-Dubilier AR-20 rotator makes an ideal mounting surface for the elevation rotator. If commercially fabricated components are to be used throughout, a mounting plate similar to that shown in Fig 5B can be purchased. The adapter plate may be used to fasten two rotators together.

### ELEVATION CONTROL USING SYNCHROS

Many amateurs have adapted TV rotators such as the Alliance U-100 and U-110 for use as elevation rotators. For small OSCAR antennas with wide beamwidths, these rotators perform satisfactorily. Unfortunately, however, the elevation of antennas with the stock U-100 and U-110 rotators is limited to increments of 10°. This limitation, combined with the possibility of the control box losing synchronization with the motor, can cause the actual antenna elevation to differ from that desired by as much as 30° or 40° at times. With high gain, narrow beamwidth arrays, such as those needed for EME work and for high altitude satellites (Phase III), this large a discrepancy is unsuitable. (Rotators designed specifically for use in the horizontal position should be used for EME antennas. The elevation readout system described here will provide superior accuracy when used with most rotators.)

This indication system uses a pair of *synchro transformers* to provide an accurate, continuous readout of the elevation angle of the antenna array. The Alliance rotator control unit is modified so that the motor can be operated to provide a continuously variable angle of antenna elevation. [Jim Bartlett, K1TX](#), described this system in June 1979 *QST*.

The synchro or Selsyn is a specialized transformer. See Fig 6A. It can be best described as a transformer having three secondary windings and a single *rotating* primary winding. Synchros are sometimes called “one-by-threes” for this reason. When two synchros are connected together as in Fig 6B and power is applied to their primary windings, the shaft attached to the rotating primary in one synchro will track the position of the shaft and winding in the other. When two synchros are used together in such an arrangement, the system is called a *synchro repeater loop*.

In repeater loops, one synchro transformer is usually

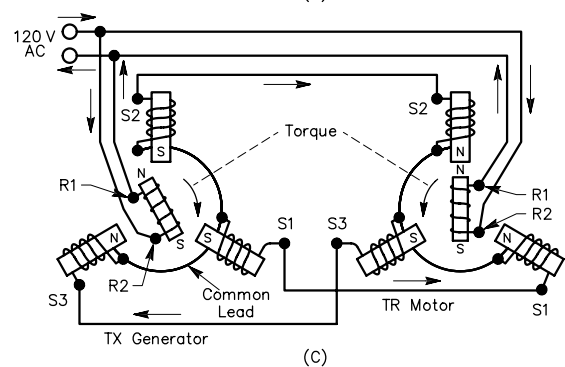
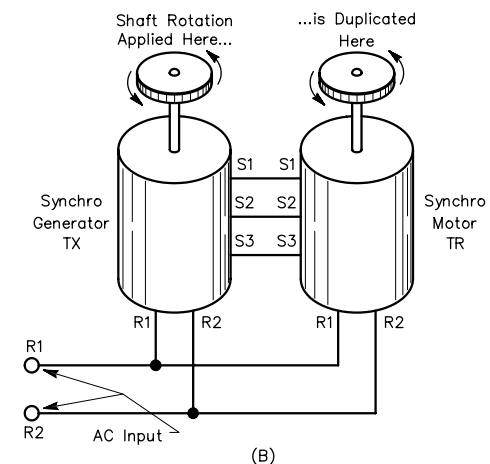
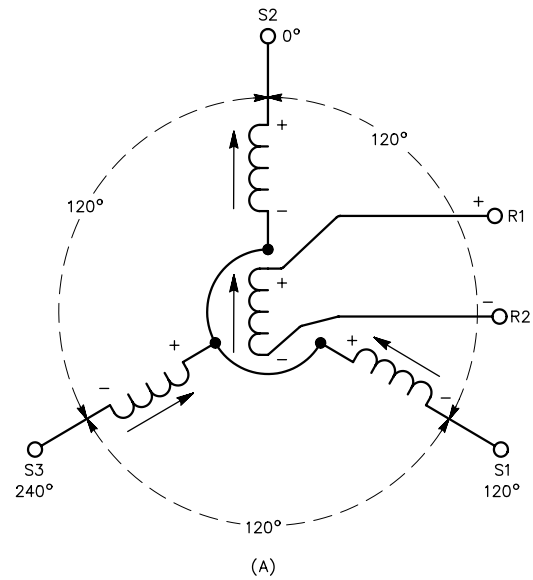


Fig 6—At A, a schematic diagram of the synchro or Selsyn transformer. Connection of two synchros in a repeater loop is shown at B. The drawing at C shows the instantaneous forces in the repeater loop with the rotor shafts at different positions. The “TX” and “TR” notations stand for *torque transmitter* and *torque receiver*, respectively. Synchros are sometimes listed in catalogs by these “type” symbols.

designated as the one where motion is initiated, and the other repeats this motion. When two synchro transformers are used in such a repeater loop, the individual units can be thought of as “transmitter” and “receiver,” or *synchro generator* and *synchro motor*, respectively. In this application (where one unit is located at the antenna array and another is used as an indicator), the antenna unit is referred to as the generator and the indicator unit the motor.

The synchro generator is so named because it electrically transmits a rotational force to the synchro motor. The motor, also sometimes called the *receiver*, *follower* or *repeater*, receives this energy from the generator, and its shaft turns accordingly.

### Physical Characteristics

Synchro transformers, both generator and motor types, resemble small electric motors, with only minor differences. Generator and motor synchros are identical in design for all practical purposes. The only difference between them is the presence of an inertia damper—a special flywheel—on units specifically designated as synchro motors. For antenna use, the inertia damper is not a necessity.

Fig 6A shows the synchro transformer schematically. In each synchro, there are two elements: the fixed secondary windings, called the *stator*, and the rotatable primary, called the *rotor*. The rotor winding is connected to a source of alternating current, and the shaft is coupled to a controlling shaft or load—in this case, the antenna array or elevation readout pointer. An alternating field is set up by the rotor winding as a result of the ac voltage applied to it. This causes voltages to be induced in the stator windings. These voltages are representative of the angular position of the rotor.

The stator consists of many coils of wire placed in slots around the inside of a laminated field structure, much like that in an electric motor. The stator coils are divided into three groups spaced 120° around the inside of the field with some overlap to provide a uniform magnitude of attractive force on the rotor. The leads from the rotor and stator windings are attached to insulated terminal strips, usually located at the rear of the motor or generator housing. The rotor connections are labeled R1 and R2, and the stator connections S1, S2 and S3. These are shown in Fig 6A. These rotor and stator designations are standard identifications.

### Synchro Transformer Action

Synchros operate much like transformers. The main difference between them is that in a synchro, the primary winding (rotor) can be rotated through 360°.

The ac applied to the synchro rotor coil varies, but the most common ratings are 115 V/60 Hz, 115 V/400 Hz, and 26 V/400 Hz. The 400-Hz varieties are easier to find on the surplus market, but are more difficult to use, as a 400-Hz supply must be built. Bartlett, K1TX, used 90-V/60-Hz synchros for this project, and the 90 V required was obtained by using two surplus transformers back to back (one 6.3 V and one 5 V). Regardless of the voltage or line frequency

used, synchros should be fused, and *isolated from the ac mains by a transformer*. This is important to ensure a safe installation.

The voltages induced in the stator windings are determined by the position of the rotor. As the rotor changes position and different values are induced, the direction of the resultant fields changes.

When a second synchro transformer is connected to the first, forming a generator/motor pair or repeater loop, the voltages induced in the three generator stator coils are also induced into the respective motor stator coils. As long as the two rotor shafts are in the same position, the voltages induced in the stator windings of the generator and motor units are equal. These voltages are of opposite polarity, however, because of the way the two units are connected together. This results in a zero potential difference between the stators in the two synchro units, and no current flows in either set of stator coils.

With the absence of current flow, no magnetic field is set up by the stator windings, and the system is in mechanical equilibrium. (There are no unbalanced forces acting on either rotor.) This situation exists whenever the two rotors are aligned in identical angular positions, regardless of the specific angle of displacement from the zero point (S2).

The repeater action of the two-synchro system occurs when one rotor is moved, causing the voltages in the system to become unbalanced. When this happens, current flows through the stator coils, setting up magnetic fields that tend to pull the rotors together so that the static (equilibrium) condition again exists. A torque results from the magnetic fields set up in both units, causing the two rotors to turn in opposite directions until they align themselves.

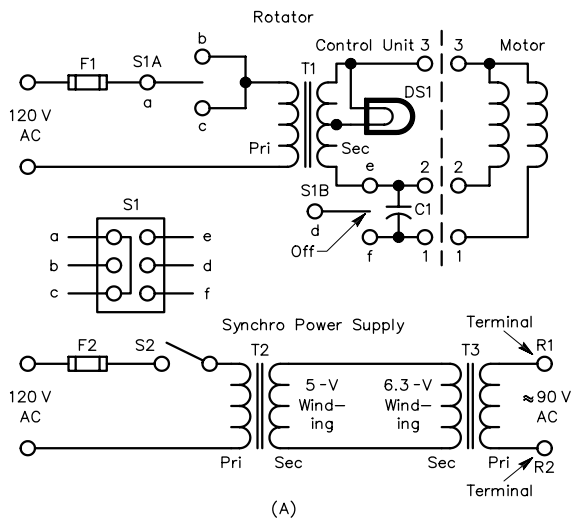
The generator shaft, however, is usually attached to a control shaft or large load (relative to that attached to the motor shaft) so that it cannot freely rotate. Thus, as long as the motor rotor is free to move, it will remain in alignment with the generator rotor. Fig 6C shows the instantaneous forces present in a repeater loop when one rotor is turned.

### Selecting the Synchros

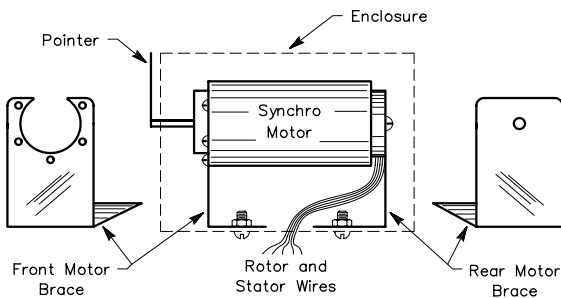
Synchro operating voltages are not critical. Most units will function with voltages as much as 20% above or 30% below their nominal ratings. Make sure the transformer(s) you use will handle the necessary current. Fig 7A shows how to connect two transformers to obtain 90 V for the units used in this project.

Synchro transformers normally found in surplus catalogs and at flea markets may not be suitable for this application. Some of the types you should not buy are ones marked *differential generator*, *differential synchro* or *resolver synchro*. These synchros are designed for different uses.

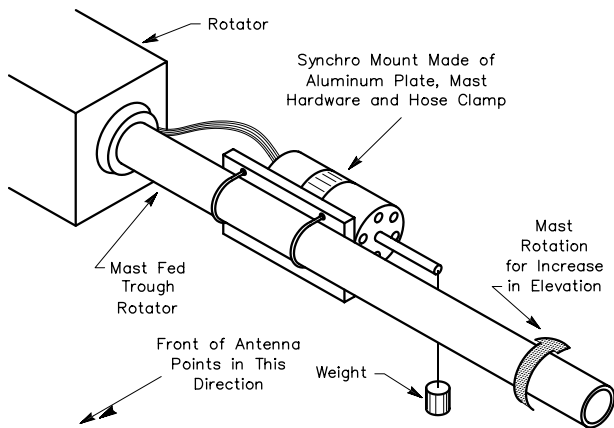
Most catalogs list synchro transformers with their ratings and prices. Look for the least expensive set of synchros that will operate at the required voltage and line frequency. When comparing specifications, look for synchros that have a high torque gradient (accuracy). It is possible



(A)



(B)



(C)

**Fig 7**—Shown at A are the circuits for the modified control unit and the synchro power supply. T1, DS1 and C1 are from the stock U-100 or U-110 control box. See text. At B, the mounting method used to secure the synchro motor is shown. Details of the synchro generator mounting are shown at C. See text for description of materials.

F1, F2—1 A, 250 V fuse.

S1—DPDT momentary contact, center off toggle switch.

S2—SPST toggle switch.

T2, T3—Transformers selected for proper voltage to synchro rotor.

to obtain accuracy as good as  $\pm 1^\circ$  with a properly installed synchro readout system.

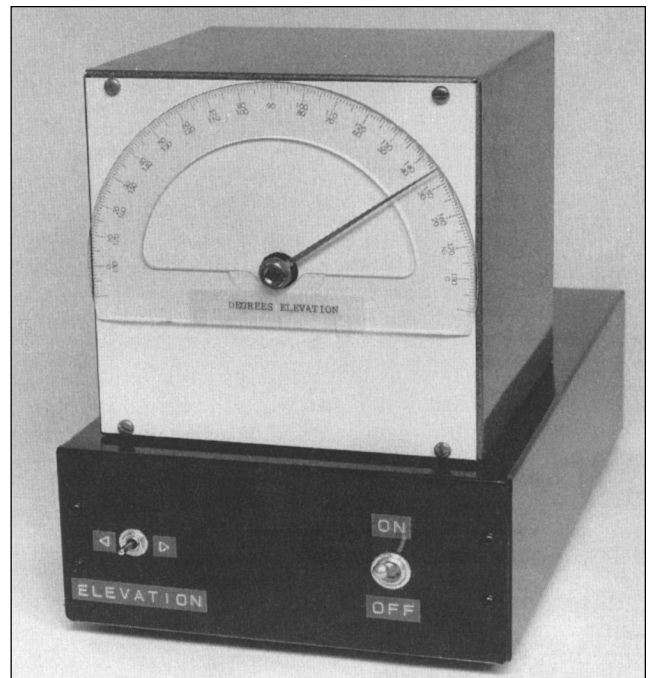
When the synchros have been obtained and a power supply designed, begin construction of the elevation system. Check the synchros by connecting the two units as shown in Fig 6B. Verify proper operation. Set the synchros aside and begin modification of the Alliance rotator-control unit (if you have decided to use an Alliance rotator).

### The Alliance Rotator-Control Unit

Remove the transformer, capacitor and pilot light from the control unit and discard the rest. Mount the transformer and capacitor in a small, shallow enclosure, like the one shown in Fig 8. The synchro power supply will also be mounted in this box.

Wire the rotator control circuit as shown in Fig 7A. The transformer, pilot light and capacitor shown are the ones removed from the Alliance control unit. Add a fuse at the point shown. The 120-V input to this circuit can be tied to that of the power supply circuit if desired. This allows for a common fuse and power switch. The rating of the fuse depends on the current drain of the synchros used, but a 1-A fuse should be ample to handle the control and power supply circuits. Note that there are four wires in the Alliance control system. Only three are needed here; the fourth wire is not used.

Test the control unit before mounting the rotator on the mast. Connect the motor to the modified control unit and check to see that it rotates properly in both directions when S1 is activated. This switch should be a DPDT,



**Fig 8**—The completed control/readout unit for antenna elevation. The dial face was made from a plastic protractor.



momentary on, center off toggle switch. Next install the synchro power supply inside the rotator-control enclosure. Some type of multiconnector plug and jack combination should be used at the rear of the cabinet so the rotator and synchro control wires can be easily disconnected from the control box. Eight wires are used between the control unit and the synchro and rotator mounted at the antenna array. An 8-pin, octal connector set and standard 8-wire rotator cable were used in this project. A suitable alternative connector set is Calectro F3-248 (male cord) and F3-268 (female chassis).

### Mechanical Details

The synchro motor providing the elevation readout is mounted inside a cube-shaped chassis. (Any suitable chassis will do.) Two aluminum brackets support the motor inside the box, as shown in Fig 7B. The motor is positioned to allow the shaft to protrude through the front panel of the enclosure. The pointer is fashioned from a scrap of copper sheet, and soldered to the edge of a washer. This is secured to the shaft between two nuts. A large protractor that fits the front of the enclosure serves as the dial face.

### Mounting and Calibration

The synchro generator mounting is shown in Fig 7C. An aluminum plate is drilled and fitted with standard hardware. Cut two slots between the clamps, and insert a large stainless steel hose clamp through the slots and around the generator casing. After positioning the synchro, tighten the clamp. The generator is mounted close to the rotator and directly behind the elevation mast when the antennas are pointed at the horizon.

The elevation and azimuth rotators are mounted in the normal fashion, as shown in Fig 9. Elevation of the antennas causes generator shaft rotation through a weighted rod fastened to the synchro shaft, as shown in Fig 7C.

As the antenna array is elevated, the synchro generator moves through an arc starting behind the elevation mast, through a position directly below the mast, to one in front

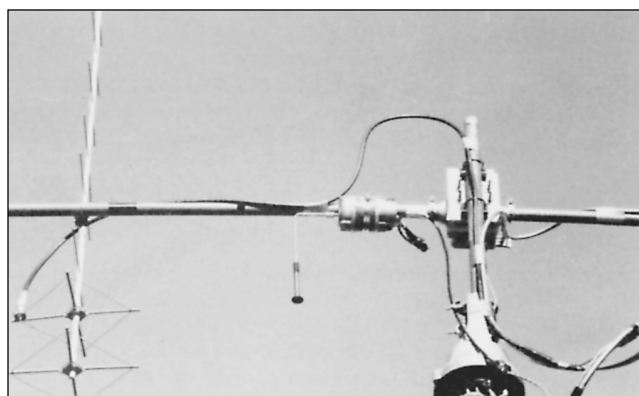


Fig 9—Close-up photo of the synchro transformer mounting method. The weighted arm is kept short to minimize wind effects on elevation readout.

of it. During the swing through this arc, gravity keeps the weighted rod perpendicular to the ground, and the synchro shaft turns in proportion to the elevation angle. (If high winds are common in your area, keep the “plumb-line” swing arm short so gusts of wind won’t cause fluctuations in the elevation readout.)

The easiest way to calibrate the system is to attach the antennas and synchro to the mast when the elevation rotator is at the end of rotation (at a stop). Do this so any movement must be in the direction that will elevate the array with respect to the horizon. With the antennas pointing at the horizon, set the synchro motor pointer to 0° at one end of the protractor scale. The proper “zero” end depends on the specific mounting scheme used at the antenna.

If the generator is mounted as shown in Fig 7C and all connections are properly made, the elevation needle should swing from right to left as the antennas move from zero through 90 to 180°. If not, remove power from the system and interchange the S1 and S3 wires at the indicator motor.

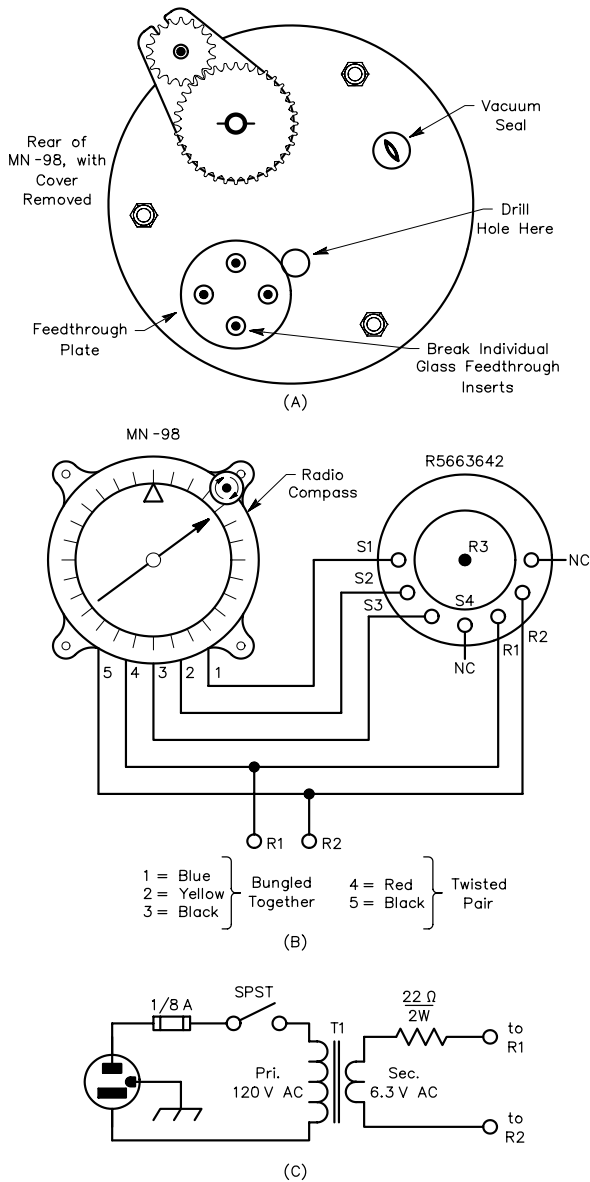
### A RADIO-COMPASS ELEVATION READOUT SYSTEM

As described by Jim Bartlett, K1TX, in September 1979 *QST*, an MN-98 Canadian radio compass and a Sperry R5663642 synchro transmitter combine to make a highly precise elevation indicator. These components, displayed in Fig 10, may be available from Fair Radio Sales Co., PO Box 1105, Lima, OH 45802. The AY-201 transmitter is *not* suitable for this project.

Place the MN-98 indicator face down on a soft cloth on a flat surface and remove the rear cover of the indicator unit. Disconnect the four wires that go to the glass-metal feedthrough located on the back panel. This frees the rear cover. Remove the rear cover and put it aside. Drill a small



Fig 10—The MN-98 Canadian radio compass and Sperry R5663642 synchro transmitter. Note the small knob at the upper right-hand corner of the indicator face. This can be used to calibrate the system without making any changes at the antenna end. By turning this knob, you can rotate the degree markings around the outside of the dial face so that any desired heading can be placed in line with the pointer.



**Fig 11—The rear of the MN-98 Canadian radio compass is shown at A. The drawing at B shows the interconnecting method used between the MN-98 and the Sperry synchro transmitter. The schematic diagram at C shows the power supply used with this indicator system. T1 can be Radio Shack 273-1384 or any junk-box 6.3-V transformer.**

hole in the rear of the case, next to the edge of the feedthrough. (See **Fig 11A.**) Do this *carefully*, making sure that the drill bit doesn't push through into the inside of the indicator shell and get tangled in the wiring. When the bit breaks through the metal casing, the pressurized seal will be broken.

Using a small screwdriver and a hammer, tap each of the individual glass feedthrough inserts, cracking them. Try to keep the screwdriver from pushing the broken pieces of glass down into the enclosure where they could get lodged in the dial mechanism. Attempt to shake all the pieces of glass out of the case. The remaining part of the feedthrough can be removed by heating with a soldering iron and prying with a screwdriver or needle-nosed pliers.

After the feedthrough has been removed, gently pull the ends of the wires out through the hole left by the feedthrough. Clip off the feedthrough terminal pins. There are five wires—a group of three and two others. The group of three will probably be blue, yellow and black. The other two wires twisted together should be red and black. Fig 11B shows how these are connected to the terminals on the synchro transmitter in a five-wire system.

### Construction of the System

Fig 11C shows the schematic diagram of a simple 6.3-V ac power supply for the indicator system. Because the synchro and indicator were originally designed to operate from 26 V at 400 Hz, a 6.3-V transformer is acceptable for use at 60 Hz. A 22- $\Omega$  resistor is wired in series with the synchros to limit current and thus eliminate an annoying buzzing sound in the indicator unit at certain pointer positions.

The indicator, along with the power supply, can be mounted in a small metal enclosure. Include a fuse, ON-OFF switch, and three-wire line cord. At the synchro transmitter end (at the antenna), provide some kind of shield to keep weather from affecting the system.

A small weight, cut in the shape of a large pie section and drilled to fit the synchro transmitter shaft, can be mounted on the shaft and shielded with a small margarine tub which is taped or glued to the outside of the synchro casing. This arrangement should allow free movement of the weight, yet keep high winds or heavy icing from affecting the indicator. The synchro transmitter should be mounted to the mast in such a way that it will rotate with the antennas, causing the weight to turn the shaft.

# Antennas for Satellite Work

This section contains a number of antenna systems that are practical for satellite communications. Some of the simpler ones bring space communications into the range of any amateur's budget.

## RECEIVING ANTENNAS FOR 29.4 MHz

Fig 12 shows three antennas suitable for satellite downlink reception at 29 MHz. At A is a turnstile, an antenna that is omnidirectional in the azimuth plane. The vertical pattern depends on the height above ground. (This subject is treated in detail in Chapter 3.) The circular polarization of the turnstile at high elevation angles reduces signal fading from satellite rotation and ionospheric effects.

The antenna at B is a simple rotatable dipole for use when a satellite is near the horizon and some directivity is helpful. When horizontally mounted, the full-wave loop at C gives good omnidirectional reception for elevation angles above 30°. It should be mounted at least  $\frac{1}{8} \lambda$  above ground. It is difficult to predict which antenna will deliver the best signal under any circumstances. All are inexpensive, and the most effective amateur satellite stations have all three, with a means of selecting the best one for the existing conditions. For low-altitude satellites, conditions should be expected to change in the matter of a few minutes.

### A 146-MHz TURNSTILE ANTENNA

The 146-MHz antenna of Fig 13 is simple and effective for use with OSCAR Modes A, B and J. The antenna, called a turnstile-reflector array, can be built very inexpensively and put into operation without the need for test equipment. The information contained here is based on a September 1974 *QST* article by Martin Davidoff, K2UBC.

Experience with several amateur satellites has shown that rapid fading is a severe problem in satellite work. Fortunately, the ground station has control over two important parameters affecting fading: cross polarization between the ground-station antenna and OSCAR antenna, and nulls in the ground-station antenna pattern. Fading that results from cross polarization can be reduced by

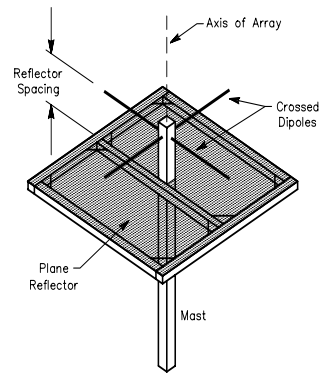


Fig 13—The turnstile-reflector (TR) array consists of crossed dipoles above a 4-foot square screen reflector.

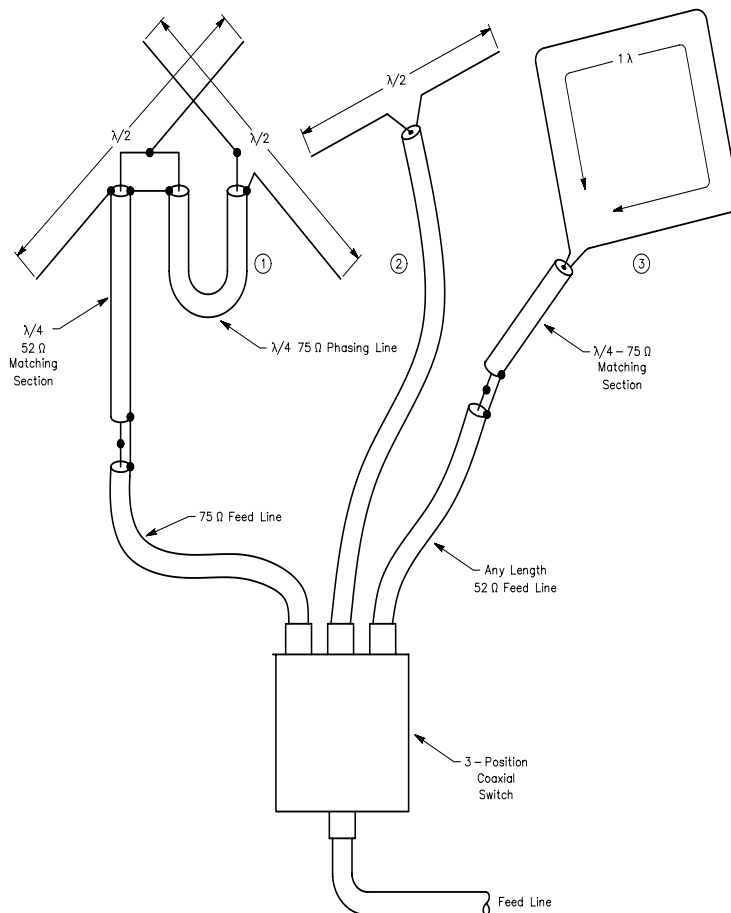


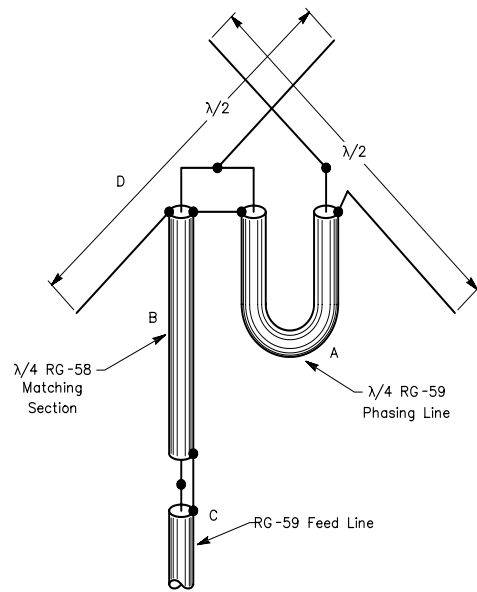
Fig 12—Any one of three 29-MHz antennas—a turnstile (A), rotary dipole (B), or horizontal loop (C)—may be selected for OSCAR downlink reception.

using a circularly polarized ground-station antenna. Fading caused by radiation pattern nulls can be overcome by (1) using a rotatable, tiltable array and continuously tracking the satellite or (2) using an antenna with a broad, null-free pattern. The turnstile-reflector array solves these problems, as it is circularly polarized at high elevation angles and has a balloon-like high-angle directivity pattern. At lower elevation angles the polarization is elliptical. (Circular and elliptical polarizations are discussed later in this chapter.)

### Construction

The mast used to support the two dipoles is made of wood, being 2 inches square and 8 feet long. The dipoles may be made of #12 copper wire, aluminum rod, or tubing. The reflecting screen is 20 gauge hexagonal poultry netting, 1-inch mesh, stapled to a 4-foot square frame made of furring strips. Hardware cloth can be used in place of the poultry netting. Corner bracing of the reflector screen provides increased mechanical stability. Spar varnish applied to the wooden members will extend the service life of the assembly.

Dimensions for the two dipole antennas and the phasing network are shown in **Fig 14**. Spacing between the dipole antennas and the reflecting screen affects the antenna radiation pattern. Choose the spacing for the pattern that best suits your needs from data in **Chapter 3**, and construct the antenna accordingly. A spacing of  $\frac{3}{8} \lambda$  (30 inches) is suggested. This distance provides a theoretical pattern response of  $\pm 1.5$  dB at all angles above  $15^\circ$ . Spacings greater than 30 inches will increase the response at elevation angles lower than  $15^\circ$ , but at the expense of nulls in the pattern at



**Fig 14—Dimensions and connections for the turnstile antenna. The phasing line is 13.3 inches of RG-59 coax (velocity factor = 0.66). A similar length of RG-58 cable is used as a matching section between the turnstile and the feed line. The phasing line length should be corrected for lines with other velocity factors.**

higher angles. The feed-point impedance of the array will vary somewhat, depending on the spacing between the dipole elements and the reflecting screen.

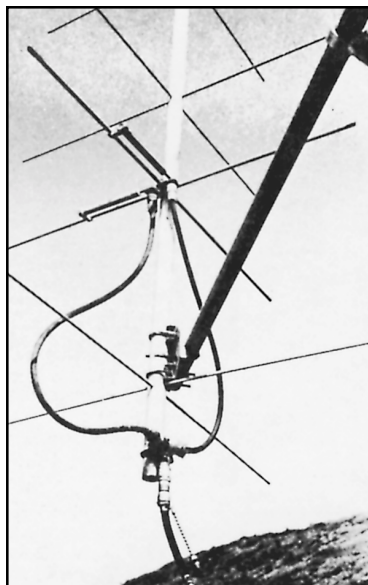
## Circular Polarization

The ideal antenna for random polarization is one with a circularly polarized radiation pattern. There are two commonly used methods for obtaining circular polarization. One is with crossed linear elements such as dipoles or Yagis. An array of crossed Yagis is shown in **Fig 15**. The second common method is with the helical antenna, described later in this chapter. Other methods also exist, such as with the quadrifilar helix (see **Maxwell** Bibliography listing at the end of this chapter).

Polarization *sense* is a critical factor, especially in EME work or if the satellite uses a circularly polarized antenna. In physics, clockwise rotation of an *approaching* wave is called “right circular polarization,” but the IEEE standard uses the term “clockwise circular polarization,” for a *receding* wave. Amateur technology follows the IEEE standard, calling clockwise polarization for a receding wave as right-hand. Either clockwise or a counter-clockwise sense can be selected by reversing the phasing harness of a crossed Yagi antenna. The sense of a helical antenna is fixed, determined by its physical construction.

In working through a satellite with a circularly polarized antenna, it is necessary to have the capability of switching the polarization sense. This is because the sense of the received signal reverses when the satellite passes its nearest point to you. If the received signal has right hand circular polarization as the satellite approaches, it will have left hand circularity as the satellite recedes. There is a sense reversal in EME work, as well, because of a phase reversal of the signal as it is reflected from the surface of the moon. A signal transmitted with right-hand circularity will be returned to the Earth with left-hand circularity.

Mathematically, linear and circular polarization are special cases of elliptical polarization. Consider two electric-field vectors at right angles to each other. The frequencies are the same, but the magnitudes and phase angles vary. If either one or the other of the magnitudes is zero, linear polarization results. If the magnitudes are the same and the phase angle between the two vectors (in time) is  $90^\circ$ , circular polarization results. Any combination between these two limits gives elliptical polarization.



**Fig 15**—This VHF crossed Yagi antenna design by KH6IJ was presented in January 1973 *QST*. Placement of the phasing harness and T connector is shown in the lower half of the photograph. Note that the gamma match is mounted somewhat off element center for better balance of RF voltages on elements.

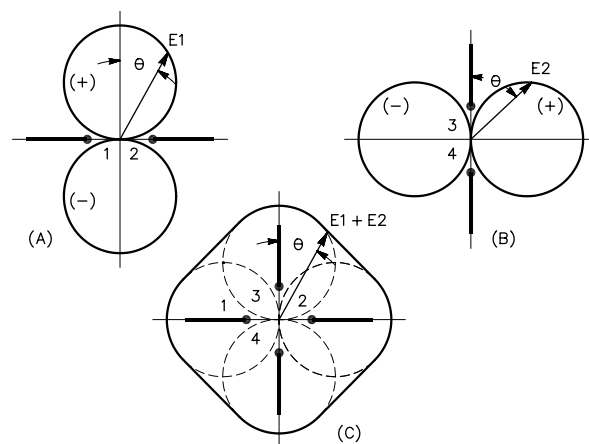
### Crossed Linear Antennas

Dipoles radiate linearly polarized signals, and the polarization direction depends on the orientation of the antenna. **Fig 16** shows the electric-field or E-plane patterns of horizontal and vertical dipoles at A and B. If the two outputs are combined with the correct phase difference ( $90^\circ$ ), a circularly polarized wave results, and the resulting electric-field pattern is shown in **Fig 16C**. Note that because the electric fields are identical in magnitude, the power from the transmitter must be equally divided between the two fields. Another way of looking at this is to consider the power as being divided between the two antennas; hence the gain of each is decreased by 3 dB when taken alone in the plane of its orientation.

As previously mentioned, a  $90^\circ$  phase shift must exist between the two antennas. The simplest way to obtain the shift is to use two feed lines with one section that is  $\frac{1}{4} \lambda$  longer than the other, as shown in **Fig 17A**. These separate feed lines are then paralleled to a common transmission line to the transmitter or receiver. Therein lies one of the headaches of this system—assuming negligible coupling between the crossed antennas, the impedance presented to the common transmission line by the parallel combination is one half that of either section alone. (This is not true when there is mutual coupling between the antennas, as in phased arrays.) A practical construction method for implementing the system of **Fig 17A** is given in **Fig 18**.

Another factor to consider is the attenuation of the cables used in the harness, along with the connectors. Good low-loss coaxial line should be used. Type N or BNC connectors are preferable to the UHF variety.

Another method of obtaining circular polarization is to use equal length feed lines and place one antenna  $\frac{1}{4} \lambda$  ahead of the other. This method is shown at B of **Fig 17**. The advantage of equal-length feed lines is that identical load



**Fig 16**—Radiation patterns looking head-on at dipoles.

impedances will be presented to the common feeder. With the phasing-line method, any mismatch at one antenna will be magnified by the extra  $\frac{1}{4} \lambda$  of transmission line. This upsets the current balance between the two antennas, resulting in a loss of polarization circularity.

**Fig 17C** shows a popular method of mounting off-the-shelf Yagi arrays—at right angles to each other. The two arrays may be physically offset by  $\frac{1}{4} \lambda$  and fed in parallel, as shown, or they may be mounted with no offset and fed  $90^\circ$  out of phase. Neither of these arrangements produces true circular polarization. Instead, polarization diversity is obtained with elliptical polarization from such a system.

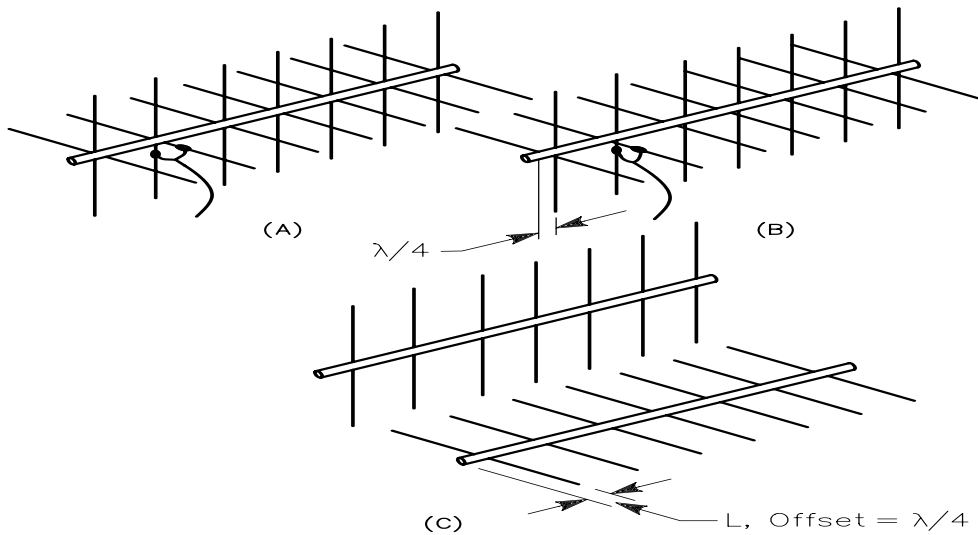
### ELLIPTICALLY POLARIZED ANTENNAS FOR 144 AND 432-MHz SATELLITE WORK

The antenna system described here offers polarization diversity, with switchable right-hand or left-hand elliptical polarization. The array can be positioned in both azimuth and elevation. This system makes use of commercially available antennas (KLM 9-element 145-MHz and KLM 14-element 435-MHz antennas), rotators (Alliance U-110 and Telex/Hy-Gain Ham series or Taitlister) and coaxial relays which are combined in a way that offers total flexibility.

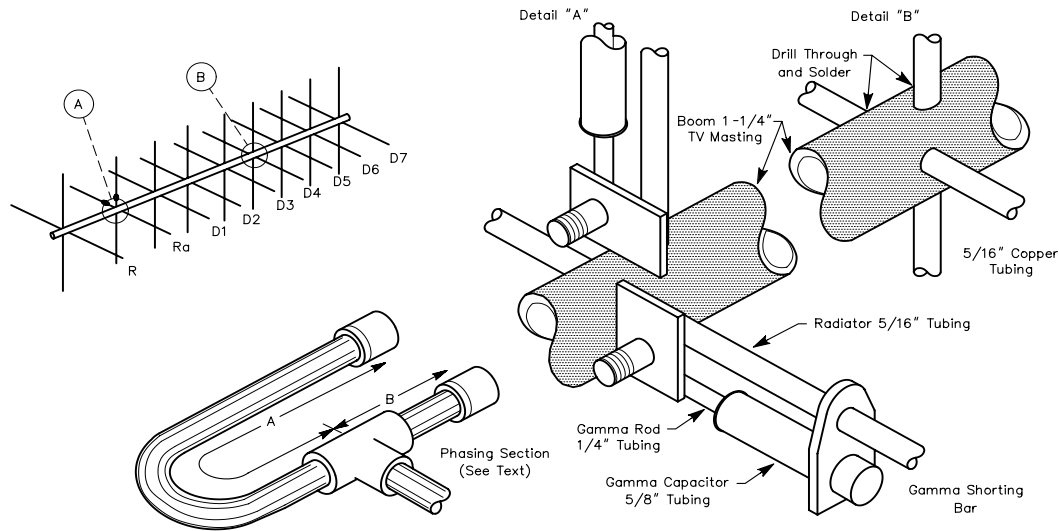
This setup is suited for Mode B or Mode J satellite operation. As shown in **Figs 19** and **20**, the whole assembly is built on a heavy-duty TV tripod so that it can be roof-mounted. The idea for this system came from Clarke Greene, K1JX.

### System Outline

The antennas shown in the photographs are actually two totally separate systems sharing the same azimuth and elevation positioning systems. Each system is identical in the way it performs—one system for 145 MHz and one for 435 MHz. Individual control lines allow independent control of the polarization sense for each system. This is mandatory, as often a different polarization sense is required for the uplink and downlink. Also, throughout any given pass of a satellite, the required sense may change.



**Fig 17—Evolution of the circularly polarized Yagi.** The simplest form of crossed Yagi, A, is made to radiate circularly by feeding the two driven elements  $90^\circ$  out of phase. Antenna B uses the same line length for both feeds, but has the elements of one bay  $\frac{1}{4} \lambda$  forward from those in the other. Antenna C offers polarization diversity with elliptical polarization. With separate booms, the elements in one set are perpendicular to those in the other. The set on the right has its elements  $\frac{1}{4} \lambda$  forward of those on the left.



**Fig 18—Construction details of a crossed Yagi antenna.**

### Mechanical Details

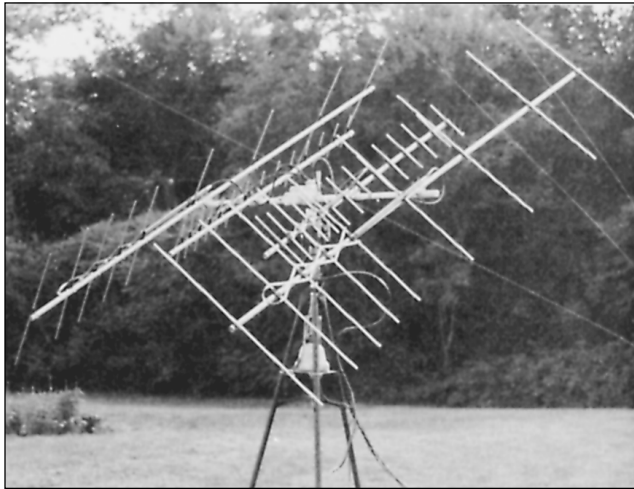
The azimuth rotator is mounted inside the tripod by means of a Rohn 25 type of rotator plate. See Fig 20. U bolts around the tripod legs secure the plate to the tripod. A length of 1-inch galvanized water pipe (the mast) extends from the top of the rotator through a homemade aluminum bearing at the top of the tripod. Because a relatively small diameter mast is used, several pieces of shim material are required between it and the body of the rotator to assure that the mast will be aligned in the bearing through  $360^\circ$  of rotation. This is covered in detail in the Telex/Hy-Gain rotator instruction sheets.

The Alliance U-110 elevation rotator is mounted to the

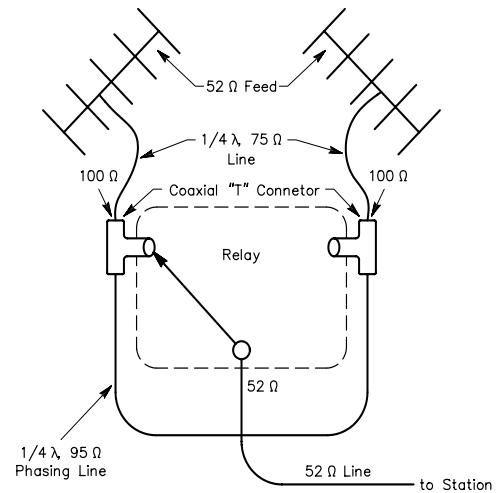
1-inch water pipe mast by means of a  $\frac{1}{8}$ -inch aluminum plate. TV U-bolt hardware provides a good fit for this mast material. The cross arm that supports the antennas is a piece of  $\frac{1}{4}$ -inch-thick fiberglass rod, 6 feet in length. Other materials can be used, but the strength of fiberglass makes it desirable as a cross arm. This should be a consideration if you live in an area that is frequented by ice storms. Although it is relatively expensive (about \$3 to \$4 per foot), one piece should last a lifetime.

### Electrical Details

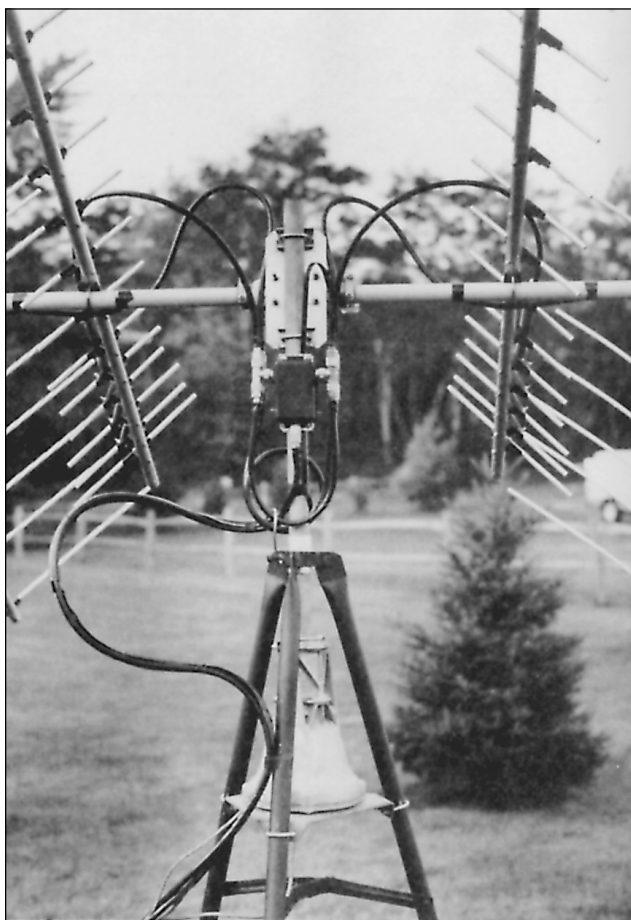
As the antenna systems are identical, this description applies to both. As mentioned earlier, it is possible to obtain



**Fig 19—An elliptically polarized antenna system for satellite communications on 146 and 435 MHz. The array is assembled from KLM log periodic Yagis.**



**Fig 21—Electrical diagram of the switchable polarization antenna system, complete with cable specifications. When calculating the lengths of individual cables, be sure to include the proper velocity factor of the cable used.**

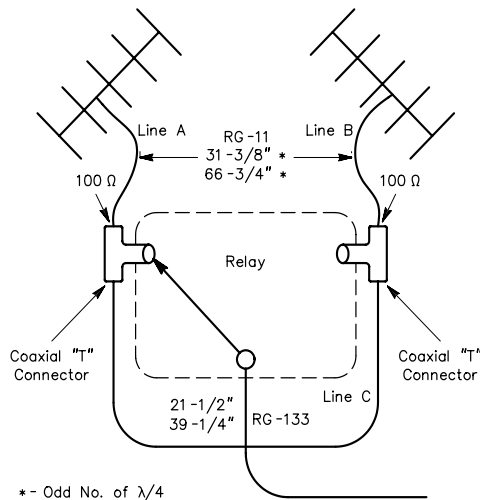


**Fig 20—The polarization sense of the antenna is controlled by coaxial relays and phasing lines. The 146 and 435-MHz systems are controlled independently.**

polarization diversity with two separate antennas mounted apart from each other as shown in the photographs. One advantage of this system is that the weight distribution on each side of the elevation rotator is equal. As long as the separation between antennas is small, performance should be nearly as good as when both sets of elements are on a single boom. There is no operational difference between true circular polarization and the polarization diversity provided by this antenna system.

Because of mutual coupling between the arrays, the two feed-point impedances will not be identical, but from a practical standpoint the differences are almost insignificant. One antenna must be fed  $90^\circ$  out of phase with respect to the other. For switchable right-hand and left-hand polarization, some means must be included to shift a  $90^\circ$  phasing line in series with either antenna. Such a scheme is shown in **Fig 21**. Since two antennas are essentially connected in parallel, the feed impedance will be half that of either antenna alone. The antennas used in this system have a  $52\text{-}\Omega$  feed-point impedance. RG-133 ( $95\text{-}\Omega$  coax) proves difficult to locate. RG-63 ( $125\text{-}\Omega$  impedance) may be used with a slightly higher mismatch. As can be seen in the drawing, the phasing line is always in series with the system feed point and one of the antennas. As shown, the antenna on the left receives energy  $90^\circ$  ahead of the one on the right. When the relay is switched, the opposite is true.

It is not necessary to use single quarter wavelengths of line. For example, the  $75\text{-}\Omega$  impedance-transforming lines between each antenna and the relay can be any odd multiple of  $1/4 \lambda$ , such as  $3/4$ ,  $5/4$ ,  $7/4 \lambda$ , etc. The same is true for the  $95$  or  $125\text{-}\Omega$  phasing line.



**Fig 22—The basic antenna system for switchable right or left-hand elliptical polarization. Lines A and B step the 52-Ω antenna impedance up to 100 Ω. The phasing line is made from 95-Ω coaxial cable to provide a good match to the 100-Ω system. See text for a detailed description of the system. The shorter lengths are for 435.15 MHz and the longer lengths are for 145.925 MHz. The line lengths shown are for a 66% velocity factor.**

Keep track of phasing-line lengths. This is especially important when determining which position of the relay will yield right or left-hand polarization. You will probably find it necessary to use a number of quarter wavelengths, because a single quarter wavelength of line is extremely short (when the velocity factor is taken into consideration). The lengths used in this system are shown in **Fig 22**. Try to use the shortest practical lengths, because the SWR bandwidth of the array decreases as the number of quarter wavelengths of line is increased.

## Antenna Systems for EME Communications

The tremendous path loss incurred over an EME circuit places stringent requirements on Earth station performance. Low-noise receiving equipment, maximum legal power and large antenna arrays are required for successful EME operation. Although it is possible to copy some of the better-equipped stations with a single Yagi antenna, it is unlikely that such an antenna can provide reliable two-way communication. Antenna gain of at least 20 dB is required for reasonable success. Generally speaking, more antenna gain yields the most noticeable improvement in station performance, as the increased gain improves both the received and transmitted signals.

Several types of antennas have become popular among EME enthusiasts. Perhaps the most popular antenna for 144-MHz work is an array of either 4 or 8 long-boom (14 to 15 dB gain) Yagis. The 4-Yagi array provides approximately 20 dB gain, and the 8-antenna system gives an approximate 3 dB increase over the 4-antenna array. At 432 MHz, 8 or 16 long-boom Yagis are often used. Yagi antennas are commercially available, and can be constructed from readily available materials. Information on maximum gain Yagi antennas is presented in [Chapter 18](#).

A moderately sized Yagi array has the advantage that it is relatively easy to construct, and can be positioned in azimuth and elevation with commercially available equipment. Matching and phasing lines present few problems. The main disadvantage of Yagi arrays is that the polarization plane of the individual Yagis cannot be conveniently changed. One way around this is to use cross polarized Yagis and a relay switching system to select the

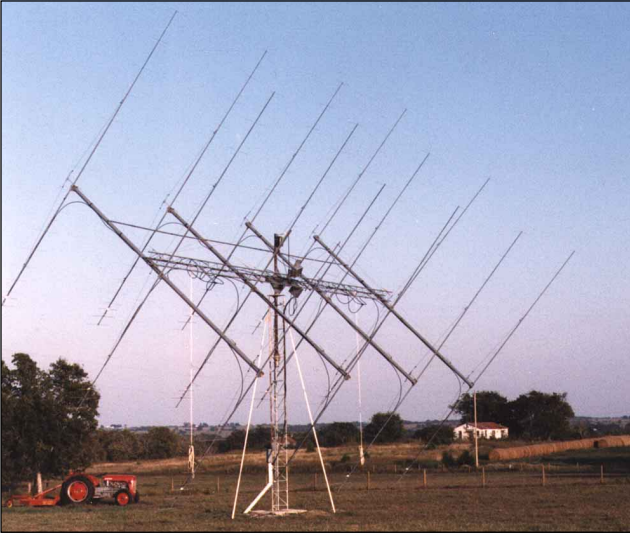
desired polarization, as described in the previous section. This represents a considerable increase in system complexity to select the desired polarization. Some amateurs have gone as far as building complicated chain driven systems to allow constant polarization adjustment of all the Yagis in a large array. Polarization shift of EME signals at 144 MHz is fairly slow, and the added complexity of the cross-polarized antenna system or a sophisticated chain-driven polarity adjustment scheme may not be worth the effort. At 432 MHz, where the polarization shifts at a somewhat faster rate, an adjustable polarization system offers a definite advantage over a fixed one.

The Yagi antenna system used by Ed Stallman, N5BLZ, is shown in [Fig 23](#). The system is comprised of 12 144-MHz long-boom 17-element Yagi antennas. The Yagi arrays of Timo Korhonen, OH6NU, and Steve Powlisken, K1FO, are shown in [Figs 24](#) and [25](#), respectively.

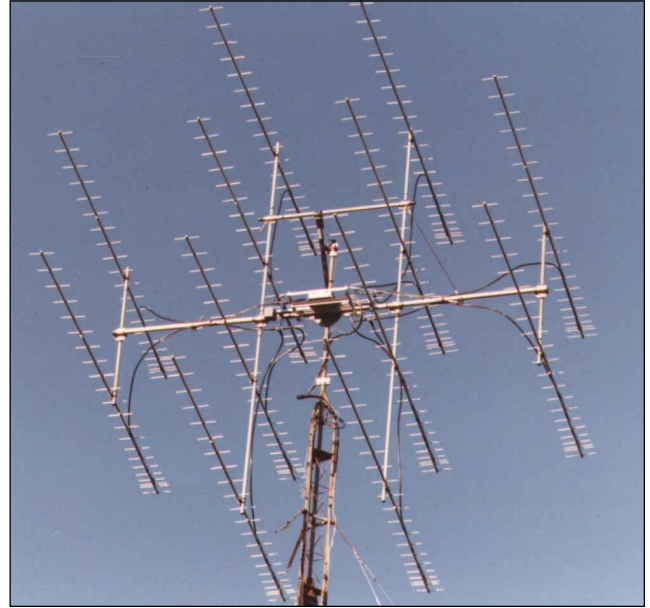
Quagi antennas (made from both quad and Yagi elements) are also popular for EME work. Slightly more gain per unit boom length is possible as compared to the conventional Yagi. Additional information on the Quagi is presented in [Chapter 18](#).

The collinear array is another popular type of antenna for EME work. A 40-element collinear array has approximately the same frontal area as an array of four Yagis, but produces approximately 1 to 2 dB less gain. One attraction to a collinear array is that the depth dimension is considerably less than the long-boom Yagis. An 80-element collinear is marginal for EME communications, providing approximately 19 dB gain. Many operators using collinear

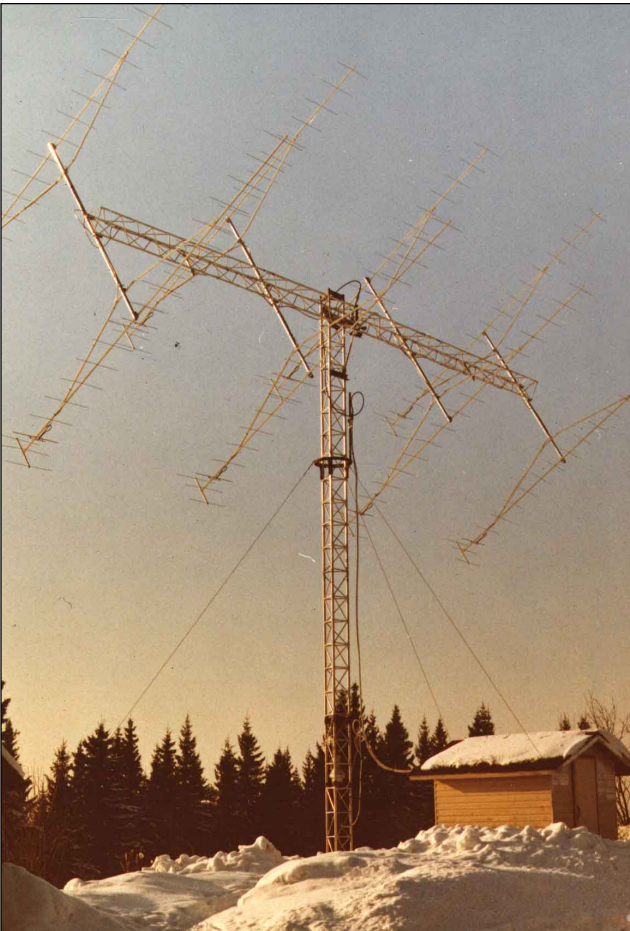




**Fig 23—**The EME antenna system used at N5BLZ consists of twelve 17-element, long boom 144-MHz Yagis. The tractor, lower left, really puts this array into perspective!



**Fig 25—**K1FO uses this system for serious moonbounce work.



**Fig 24—**The Yagi array used for EME at OH6NU/OH6NM.

arrays use 160-element or larger systems.

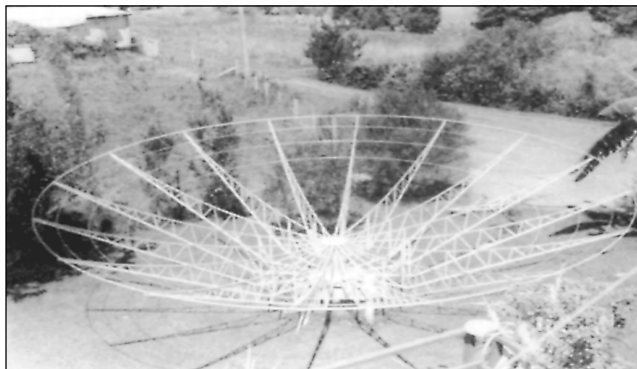
As with Yagi and Quagi antennas, the collinear cannot be adjusted easily for polarity changes. From a constructional standpoint, there is little difference in complexity and material costs between the collinear and Yagi arrays.

The parabolic dish is another antenna that is used extensively for EME work. Unlike the other antennas described, the major problems associated with dish antennas are mechanical ones. Dishes approaching 20 feet in diameter are required for successful EME operation on 432 MHz. Structures of this size with wind and ice loading place a severe strain on the mounting and positioning system. Extremely rugged mounts are required for large dish antennas, especially when used in windy locations.

Several aspects of parabolic dish antennas make the extra mechanical problems worth the trouble, however. For example, the dish antenna is inherently broadbanded, and may be used on several different bands by simply changing the feed. An antenna that is suitable for 432 MHz work is also usable for each of the higher amateur bands. Increased gain is available as the frequency of operation is increased.

Another advantage of this antenna is in the feed system. The polarization of the feed, and therefore the polarization of the antenna, can be adjusted with little difficulty. It is a relatively easy matter to devise a system whereby the feed can be rotated remotely from the shack. Changes in polarization of the signal can thereby be compensated for at the operating position.

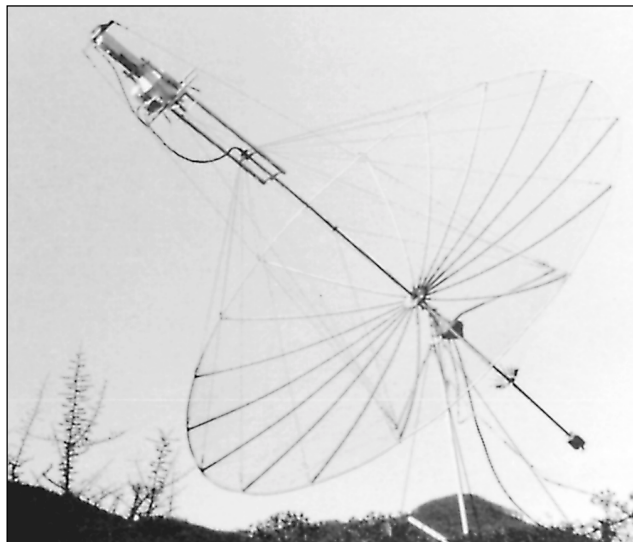
Because polarization changes can account for as much as 30 dB of signal attenuation, the rotatable feed can make



**Fig 26**—The 1/2-inch wire mesh is about all that is needed to complete this 7-meter diameter dish at ZL1BJQ.

the difference between consistent communications and no communications at all. A parabolic dish built by Dave Wardley, ZL1BJQ, is shown in **Fig 26**. The 20-foot stressed parabolic dish used at F2TU is shown in **Fig 27**. More information on parabolic dish antennas is given later in this chapter and in [Chapter 18](#).

Antennas suitable for EME work are by no means limited to the types described thus far. Rhombics, quad



**Fig 27**—This 20-foot stressed parabolic dish is used for EME work at F2TU on 432 and 1296 MHz.

arrays, helicals and others can also be used. These antennas have not gained the popularity of the Yagi, Quagi, collinear and parabolic dish, however.

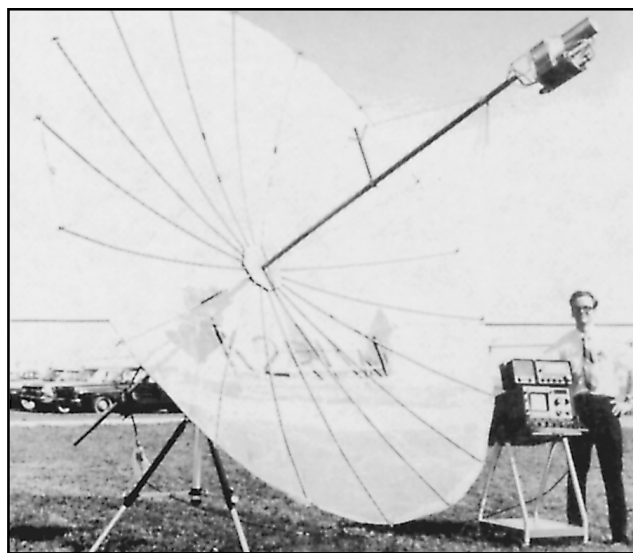
## A 12-Foot Stressed Parabolic Dish

Very few antennas evoke as much interest among UHF amateurs as the parabolic dish, and for good reason. First, the parabola and its cousins—Cassegrain, hog horn and Gregorian—are probably the ultimate in high gain antennas. One of the highest gain antenna in the world (148 dB) is a parabola. This is the 200-inch Mt. Palomar telescope. (The very short wavelength of light rays causes such a high gain to be realizable.) Second, the efficiency of the parabola does not change as size increases. With collinear arrays, the loss of the phasing harness increases as the size increases. The corresponding component of the parabola is lossless air between the feed horn and the reflecting surface. If there are few surface errors, the efficiency of the system stays constant regardless of antenna size. This project was presented by [Richard Knadle, K2RIW](#), in August 1972 *QST*.

Some amateurs reject parabolic antennas because of the belief that they are all heavy, hard to construct, have large wind loading surfaces, and require precise surface accuracy. However, with modern construction techniques, a prudent choice of materials, and an understanding of accuracy requirements, these disadvantages can be largely overcome. A parabola may be constructed with a 0.6 f/d (focal length/diameter) ratio, producing a rather flat dish, which makes it easy to surface and allows the use of recent advances in high efficiency feed horns. This results in greater gain for a given dish size over conventional designs.

Such an antenna is shown in **Fig 28**. This parabolic

dish is lightweight, portable, easy to build, and can be used for 432 and 1296-MHz mountaintopping, as well as on 2300, 3450 and 5760 MHz. Disassembled, it fits into the trunk of a car, and can be assembled in 45 minutes.



**Fig 28**—A 12-foot stressed parabolic dish set up for reception of *Apollo* or *Skylab* signals near 2280 MHz. A preamplifier is shown taped below the feed horn. The dish was designed by K2RIW, standing at the right. From *QST*, August 1972.

The usually heavy structure that supports the surface of most parabolic dish antennas has been replaced in this design by aluminum spokes bent into a near parabolic shape by string. These strings serve the triple function of guying the focal point, bending the spokes, and reducing the error at the dish perimeter (as well as at the center) to nearly zero. By contrast, in conventional designs, the dish perimeter (which has a greater surface area than the center) is farthest from the supporting center hub. For these reasons, it often has the greatest error. This error becomes more severe when the wind blows. Here, each of the spokes is basically a cantilevered beam with end loading. The equations of beam bending predict a near perfect parabolic curve for extremely small deflections. Unfortunately the deflections in this dish are not that small, and the loading is not perpendicular. For these reasons, mathematical prediction of the resultant curve is quite difficult. A much better solution is to measure the surface error with a template and make the necessary correction by bending each of the spokes to fit. This procedure is discussed in a later section.

The uncorrected surface is accurate enough for 432 and 1296-MHz use. Trophies taken by this parabola in antenna gain contests were won using a completely natural surface with no error correction.

By placing the transmission line inside the central pipe that supports the feed horn, the area of the shadows or blockages on the reflector surface is much smaller than in other feeding and supporting systems, thus increasing gain. For 1296 MHz, a backfire feed horn may be constructed to take full advantage of this feature. At 432 MHz, a dipole and reflector assembly produces 1.5 dB additional gain over a corner reflector feed system. Because the preamplifier is located right at the horn on 2300 MHz, a conventional feed horn may be used.

### Construction

**Table 1** is a list of materials required for construction. Care must be exercised when drilling holes in the connecting

**Table 1**  
**Materials List for the 12-Foot Stressed Parabolic Dish**

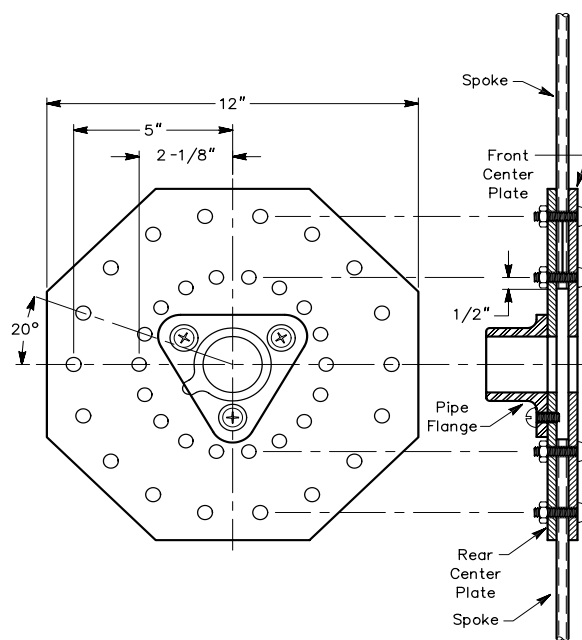
- 1) Aluminum tubing, 12 ft  $\times$  1/2 in. OD  $\times$  0.049-in. wall, 6061-T6 alloy, 9 required to make 18 spokes.
- 2) Octagonal mounting plates 12  $\times$  12  $\times$  1/8 in., 2024-T3 alloy, 2 required.
- 3) 1 1/4 in. ID pipe flange with setscrews.
- 4) 1 1/4 in.  $\times$  8 ft TV mast tubing, 2 required.
- 5) Aluminum window screening, 4  $\times$  50 ft.
- 6) 130-pound test Dacron trolling line.
- 7) 38 ft #9 galvanized fence wire (perimeter).
- 8) Two hose clamps, 1 1/2 in.; two U bolts; 1/2  $\times$  14 in. Bakelite rod or dowel; water-pipe grounding clamp; 18 eye bolts; 18 S hooks.

center plates so assembly problems will not be experienced later. See **Fig 29**. A notch in each plate allows them to be assembled in the same relative positions. The two plates should be clamped together and drilled at the same time. Each of the 18 1/2-inch diameter aluminum spokes has two no. 28 holes drilled at the base to accept no. 6-32 machine screws that go through the center plates. The 6-foot long spokes are cut from standard 12-foot lengths of tubing. A fixture built from a block of aluminum assures that the holes are drilled in exactly the same position in each spoke. The front and back center plates constitute an I-beam type of structure that gives the dish center considerable rigidity.

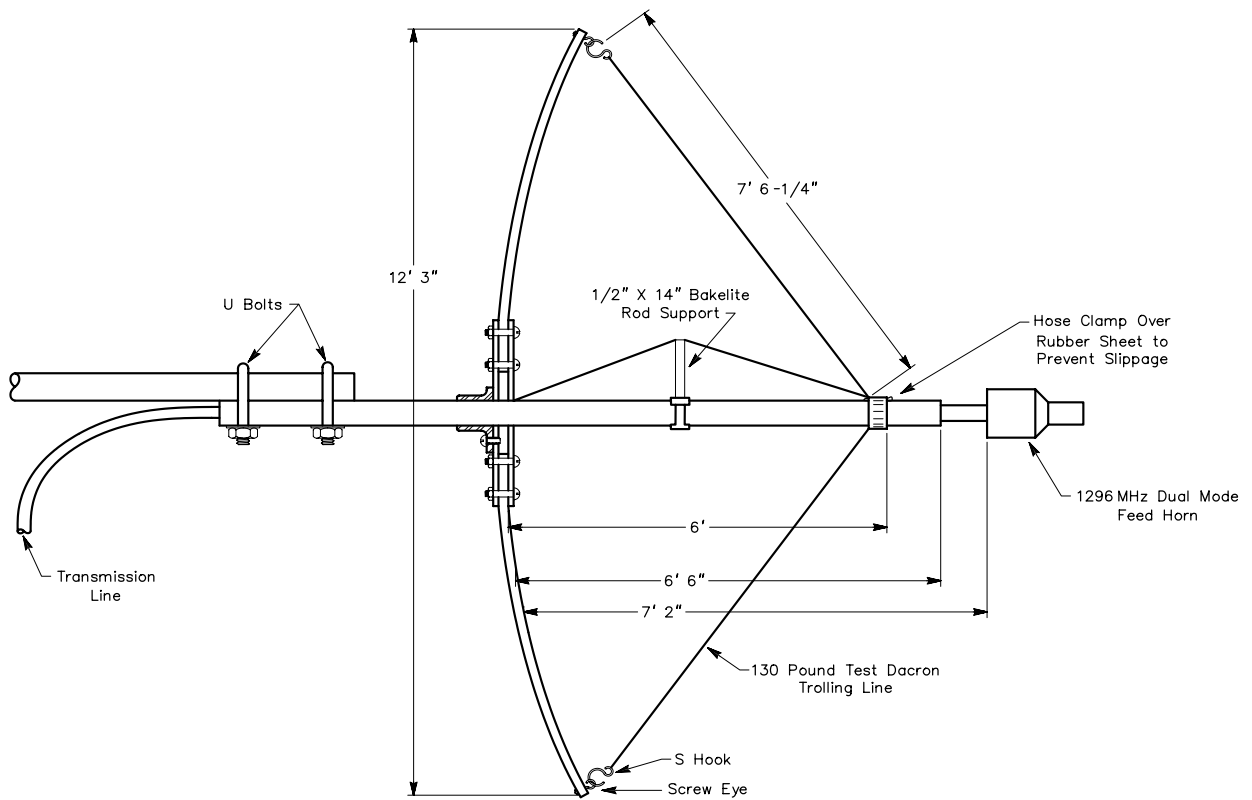
A side view of the complete antenna is shown in **Fig 30**. Aluminum alloy (6061-T6) is used for the spokes, while 2024-T3 aluminum alloy sheet, 1/8 inch thick, is used for the center plates. (Aluminum has approximately three times the strength-to-weight ratio of wood, and aluminum cannot warp or become water logged.) The end of each of the 18 spokes has an eyebolt facing the dish focal point, which serves a dual purpose:

- 1) To accept the #9 galvanized fence wire that is routed through the screw eyes to define the dish perimeter, and
- 2) To facilitate rapid assembly by accepting the S hooks which are tied to the end of each of the lengths of 130-pound test Dacron fishing string.

The string bends the spokes into a parabolic curve; the dish may be adapted for many focal lengths by tightening or slackening the strings. Dacron was chosen because it has the same chemical formula as Mylar. This is a low-stretch material that keeps the dish from changing shape. The



**Fig 29—Center plate details. Two center plates are bolted together to hold the spokes in place.**



**Fig 30—Side view of the stressed parabolic dish.**

galvanized perimeter wire has a 5-inch overlap area that is bound together with baling wire after the spokes have been hooked to the strings.

The aluminum window screening is bent over the perimeter wire to hold it in place on the back of the spokes. Originally, there was concern that the surface perturbations (the spokes) in front of the screening might decrease the gain. The total spoke area is so small, however, that this fear proved unfounded.

Placing the aluminum screening in front of the spokes requires the use of 200 pieces of baling wire to hold the screening in place. This procedure increases the assembly time by at least an hour. For contest and mountaintop operation (when the screening is on the back of the spokes) no fastening technique is required other than bending the screen to overlap the wire perimeter.

### The Parabolic Surface

A 4-foot wide roll of aluminum screening 50 feet long is cut into appropriate lengths and laid parallel with a 3-inch overlap between the top of the unbent spokes and hub assembly. The overlap seams are sewn together on one half of the dish using heavy Dacron thread and a sailmaker's curved needle. Every seam is sewn twice; once on each edge of the overlapped area. The seams on the other half are left

open to accommodate the increased overlap that occurs when the spokes are bent into a parabola. The perimeter of the screening is then trimmed. Notches are cut in the 3-inch overlap to accept the screw eyes and S hooks.

The first time the dish is assembled, the screening strips are anchored to the inside surface of the dish and the seams sewn in this position. It is easier to fabricate the surface by placing the screen on the back of the dish frame with the structure inverted. The spokes are sufficiently strong to support the complete weight of the dish when the perimeter is resting on the ground.

The 4-foot wide strips of aluminum screening conform to the compound bend of the parabolic shape very easily. If the seams are placed parallel to the E-field polarization of the feed horn, minimum feedthrough will occur. This feedthrough, even if the seams are placed perpendicular to the E field, is so small that it is negligible. Some constructors may be tempted to cut the screening into pie shaped sections. This procedure will increase the seam area and construction time considerably. The dish surface appears most pleasing from the front when the screening perimeter is slipped between the spokes and the perimeter wire, and is then folded back over the perimeter wire. In disassembly, the screening is removed in one piece, folded in half, and rolled.

## The Horn and Support Structure

The feed horn is supported by 1 $\frac{1}{4}$ -inch aluminum television mast. The Hardline that is inserted into this tubing is connected first to the front of the feed horn, which then slides back into the tubing for support. A setscrew assures that no further movement of the feed horn occurs. During antenna gain competition the setscrew is omitted, allowing the  $\frac{1}{2}$ -inch semirigid CATV transmission line to move in or out while adjusting the focal length for maximum gain. The TV mast is held firmly at the center plates by two setscrews in the pipe flange that is mounted on the rear plate. At 2300 MHz, the dish is focused for best gain by loosening these setscrews on the pipe flange and sliding the dish along the TV mast tubing. (The dish is moved instead of the feed horn.)

The fishing strings are held in place by attaching them to a hose clamp that is permanently connected to the TV tubing. A piece of rubber sheet under the hose clamp prevents slippage and keeps the hose clamp from cutting the fishing string. A second hose clamp is mounted below the first as extra protection against slippage.

The high efficiency 1296-MHz dual mode feed horn, detailed in **Fig 31**, weighs 5 $\frac{3}{4}$  pounds. This weight causes some bending of the mast tubing, but this is corrected by a  $\frac{1}{2}$ -inch diameter bakelite support, as shown in **Fig 30**. This support is mounted to a pipe grounding clamp with a no. 8-32 screw inserted in the end of the rod. The bakelite rod and grounding clamp are mounted midway between the hose clamp and the center plates on the mast. A double run of fishing string slipped over the notched upper end of the bakelite rod counteracts bending.

The success of high efficiency parabolic antennas is primarily determined by feed horn effectiveness. The multiple diameter of this feedhorn may seem unusual. This

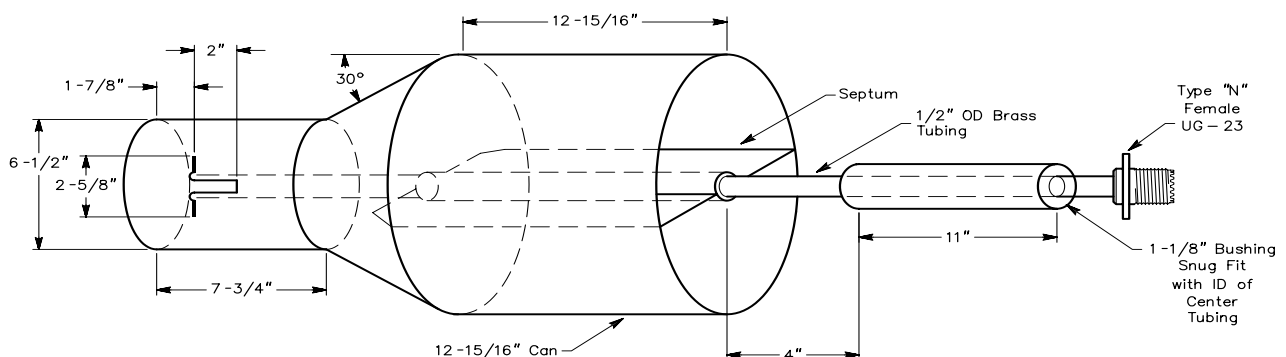
patented dual mode feed, designed by Dick Turrin, W2IMU, achieves efficiency by launching two different kinds of waveguide modes simultaneously. This causes the dish illumination to be more constant than conventional designs.

Illumination drops off rapidly at the perimeter, reducing spillover. The feed backlobes are reduced by at least 35 dB because the current at the feed perimeter is almost zero; the phase center of the feed system stays constant across the angles of the dish reflector. The larger diameter section is a phase corrector and should not be changed in length. In theory, almost no increase in dish efficiency can be achieved without increasing the feed size in a way that would increase complexity, as well as blockage.

The feed is optimized for a 0.6 f/d dish. The dimensions of the feeds are slightly modified from the original design in order to accommodate the cans. Either feed type can be constructed for other frequencies by changing the scale of all dimensions.

## Multiband Use

Many amateurs construct multiband antenna arrays by putting two dishes back to back on the same tower. This is cost inefficient. The parabolic reflector is a completely frequency independent surface, and studies have shown that a 0.6 f/d surface can be steered seven beamwidths by moving the feed horn from side to side before the gain diminishes by 1 dB. Therefore, the best dual band antenna can be built by mounting separate horns side by side. At worst, the antenna may have to be moved a few degrees (usually less than a beamwidth) when switching between horns, and the unused horn increases the shadow area slightly. In fact, the same surface can function simultaneously on multiple frequencies, making crossband duplex operation possible with the same dish.



**Fig 31**—Backfire type 1296-MHz feed horn, linear polarization only. The small can is a Quaker State oil container; the large can is a 50-pound shortening container (obtained from a restaurant, Gold Crisp brand). Brass tubing,  $\frac{1}{2}$ -inch OD, extends from UG-23 connector to dipole. Center conductor and dielectric are obtained from  $\frac{3}{8}$ -inch Alumafom coaxial cable. The dipole is made from  $\frac{3}{32}$ -inch copper rod. The septum and 30° section are made from galvanized sheet metal. Styrofoam is used to hold the septum in position. The primary gain is 12.2 dBi.

## Order of Assembly

- 1) A single spoke is held upright behind the rear center plate with the screw eye facing forward. Two 6-32 machine screws are pushed through the holes in the rear center plate, through the two holes of the spoke, and into the corresponding holes of the front center plate. Lock washers and nuts are placed on the machine screws and hand tightened.
- 2) The remaining spokes are placed between the machine screw holes. Make sure that each screw eye faces forward. Machine screws, lock washers, and nuts are used to mount all 18 spokes.
- 3) The no. 6-32 nuts are tightened using a nut driver.
- 4) The mast tubing is attached to the spoke assembly, positioned properly, and locked down with the setscrews on the pipe flange at the rear center plate. The S hooks of the 18 Dacron strings are attached to the screw eyes of the spokes.
- 5) The ends of two pieces of fishing string (which go over the bakelite rod support) are tied to a screw eye at the forward center plate.
- 6) The dish is laid on the ground in an upright position and #9 galvanized wire is threaded through the eyebolts. The overlapping ends are lashed together with baling wire.
- 7) The dish is placed on the ground in an inverted position with the focus downward. The screening is placed on the back of the dish and the screening perimeter is fastened as previously described.
- 8) The extension mast tubing (with counterweight) is connected to the center plate with U bolts.
- 9) The dish is mounted on a support and the transmission line is routed through the tubing and attached to the horn.

## Parabola Gain Versus Errors

How accurate must a parabolic surface be? This is a frequently asked question. According to the Rayleigh limit for telescopes, little gain increase is realized by making the mirror accuracy greater than  $\pm 1/8 \lambda$  peak error. John Ruze of the MIT Lincoln Laboratory, among others, has derived an equation for parabolic antennas and built models to verify it. The tests show that the tolerance loss can be predicted within a fraction of a decibel, and less than 1 dB of gain is sacrificed with a surface error of  $\pm 1/8 \lambda$ . (A  $1/8 \lambda$  is 3.4 inches at 432 MHz, 1.1 inches at 1296 MHz and 0.64 inch at 2300 MHz.)

Some confusion about requirements of greater than  $1/8\lambda$  accuracy may be the result of technical literature describing highly accurate surfaces. Low sidelobe levels are the primary interest in such designs. Forward gain is a much greater concern than low sidelobe levels in amateur work; therefore, these stringent requirements do not apply.

When a template is held up against a surface, positive and negative ( $\pm$ ) peak errors can be measured. The graphs of dish accuracy requirements are frequently plotted in terms of RMS error, which is a mathematically derived function much smaller than  $\pm$  peak error (typically  $1/3$ ). These small

RMS accuracy requirements have discouraged many constructors who confuse them with  $\pm$  peak errors.

**Fig 32** may be used to predict the resultant gain of various dish sizes with typical errors. There are a couple of surprises, as shown in **Fig 33**. As the frequency is increased for a given dish, the gain increases 6 dB per octave until the tolerance errors become significant. Gain deterioration then increases rapidly. Maximum gain is realized at the frequency where the tolerance loss is 4.3 dB. Notice that at 2304 MHz, a 24-foot dish with  $\pm 2$ -inch peak errors has the same gain as a 6-foot dish with  $\pm 1$ -inch peak errors. Quite startling, when it is realized that a 24-foot dish has 16 times the area of a 6-foot dish. Each time the diameter or frequency is doubled or halved, the gain changes by 6 dB. Each time all the errors are halved, the frequency of maximum gain is doubled. With this information, the gain of other dish sizes with other tolerances can be predicted.

These curves are adequate for predicting gain, assuming a high efficiency feed horn is used (as described earlier) which realizes 60% aperture efficiency. At frequencies below 1296 MHz where the horn is large and causes considerable blockage, the curves are somewhat optimistic. A properly built dipole and splasher feed will have about 1.5 dB less gain when used with a 0.6 f/d dish than the dual mode feed system described.

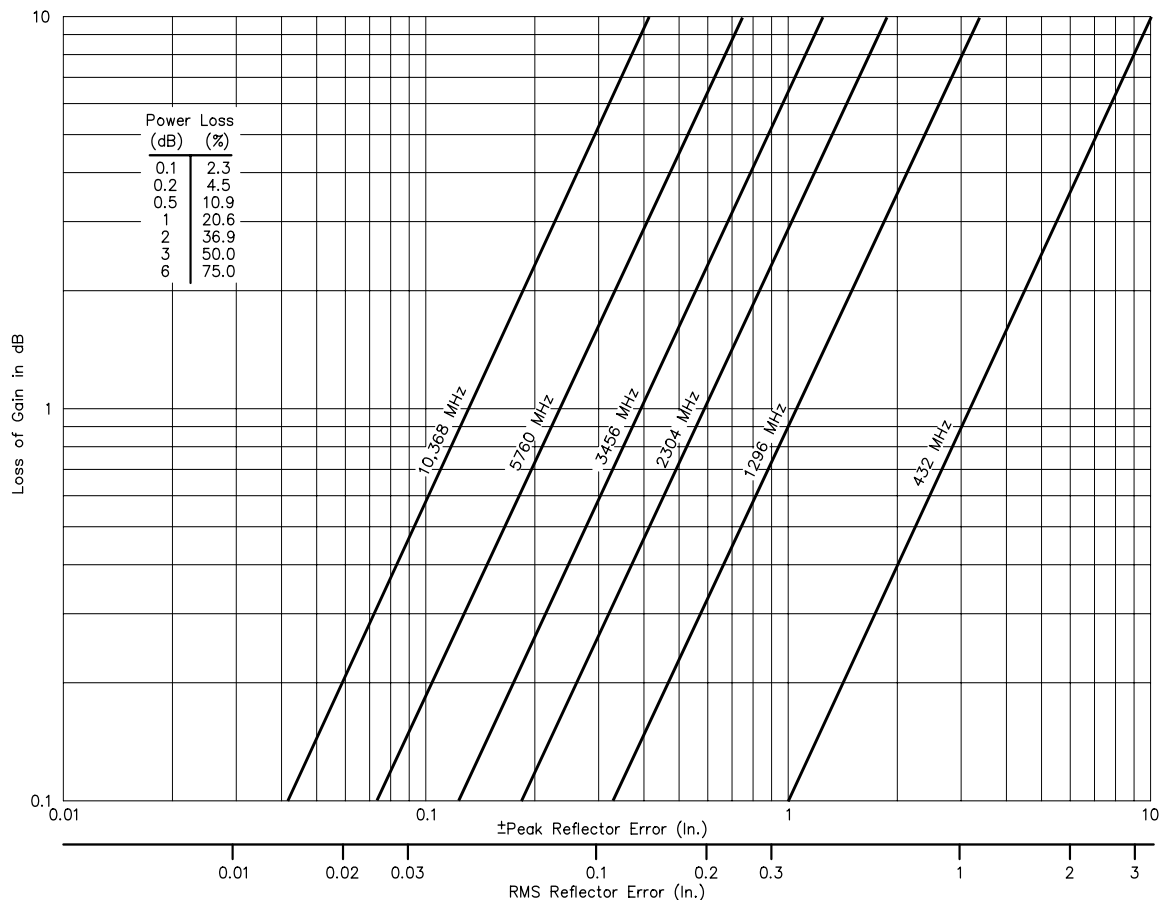
The worst kind of surface distortion is where the surface curve in the radial direction is not parabolic but gradually departs in a smooth manner from a perfect parabola. The decrease in gain can be severe, because a large area is involved. If the surface is checked with a template, and if reasonable construction techniques are employed, deviations are controlled and the curves represent an upper limit to the gain that can be realized.

If a 24-foot dish with  $\pm 2$ -inch peak errors is being used with 432 and 1296-MHz multiple feed horns, the constructor might be discouraged from trying a 2300-MHz feed because there is 15 dB of gain degradation. The dish will still have 29 dB of gain on 2300 MHz, however, making it worthy of consideration.

The near-field range of this 12-foot stressed dish (actually 12 feet 3 inches) is 703 feet at 2300 MHz. By using the sun as a noise source and observing receiver noise power, it was found that the antenna had two main lobes about  $4^\circ$  apart. The template showed a surface error (insufficient spoke bending at  $3/4$  radius), and a correction was made. A recheck showed one main lobe, and the solar noise was almost 3 dB stronger.

## Other Surfacing Materials

The choice of surface materials is a compromise between RF reflecting properties and wind loading. Aluminum screening, with its very fine mesh (and weight of 4.3 pounds per 100 square feet) is useful beyond 10 GHz because of its very close spacing. This screening is easy to roll up and is therefore ideal for a portable dish. This close



**Fig 32—Gain deterioration versus reflector error. Basic information obtained from J. Ruze, British IEE.**

spacing causes the screen to be a 34% filled aperture, bringing the wind force at 60 mi/h to more than 400 pounds on this 12-foot dish. Those considering a permanent installation of this dish should investigate other surfacing materials.

Hexagonal 1-inch poultry netting (chicken wire), which is an 8% filled aperture, is nearly ideal for 432-MHz operation. It weighs 10 pounds per 100 square feet, and exhibits only 81 pounds of force with 60 mi/h winds. Measurement on a large piece reveals 6 dB of feedthrough at 1296 MHz, however. Therefore, on 1296 MHz, one fourth of the power will feed through the surface material. This will cause a loss of only 1.3 dB of forward gain. Since the low wind loading material will provide a 30-dB gain potential, it is a very good trade-off.

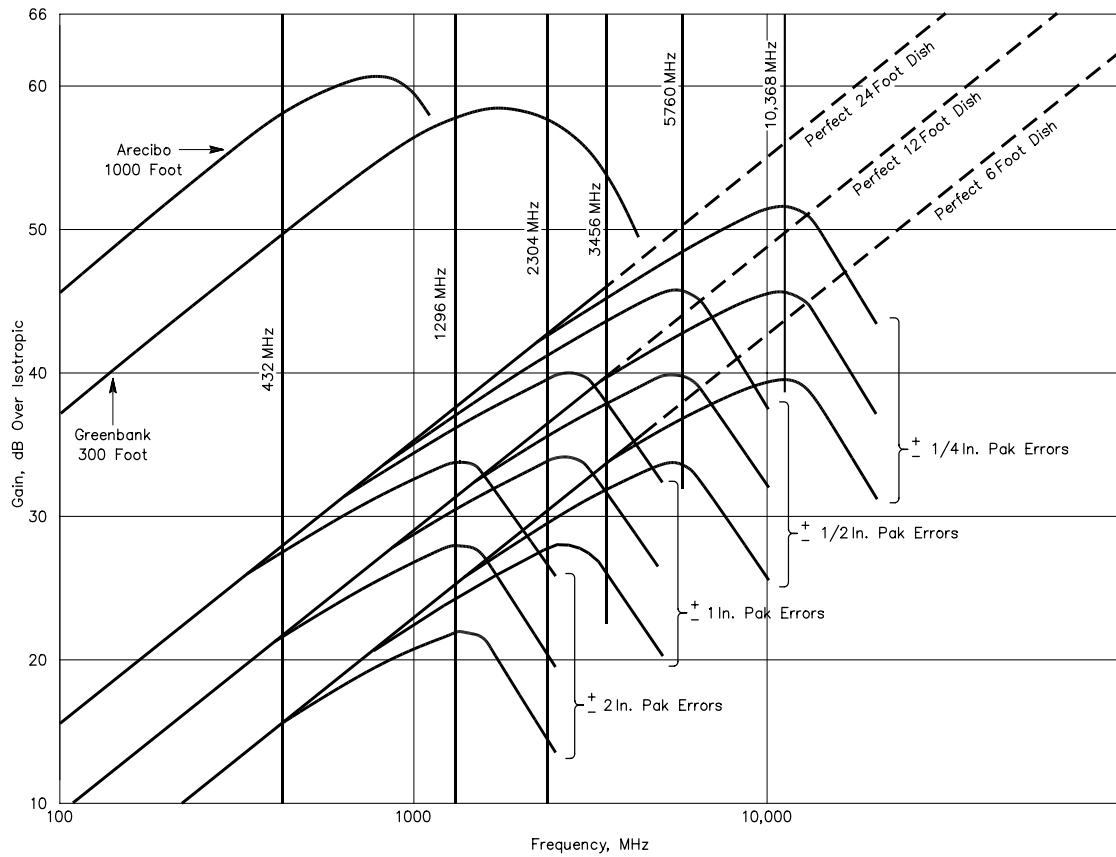
Poultry netting is very poor material for 2300 MHz and above, because the hole dimensions approach  $\frac{1}{2} \lambda$ . As with all surfacing materials, minimum feedthrough occurs when the E-field polarization is parallel to the longest dimension of the surfacing holes.

Hardware cloth with  $\frac{1}{2}$ -inch mesh weighs 20 pounds per 100 square feet and has a wind loading characteristic of 162 pounds with 60 mi/h winds. The filled aperture is 16%, and this material is useful to 2300 MHz.

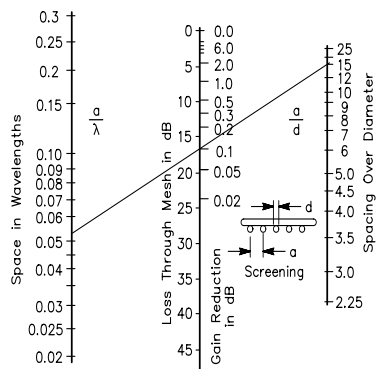
A rather interesting material worthy of investigation is  $\frac{1}{4}$ -inch reinforced plastic. It weighs only 4 pounds per 100 square feet. The plastic melts with many universal solvents such as lacquer thinner. If a careful plastic-melting job is done, what remains is the  $\frac{1}{4}$ -inch spaced aluminum wires with a small blob of plastic at each junction to hold the matrix together.

There are some general considerations to be made in selecting surface materials:

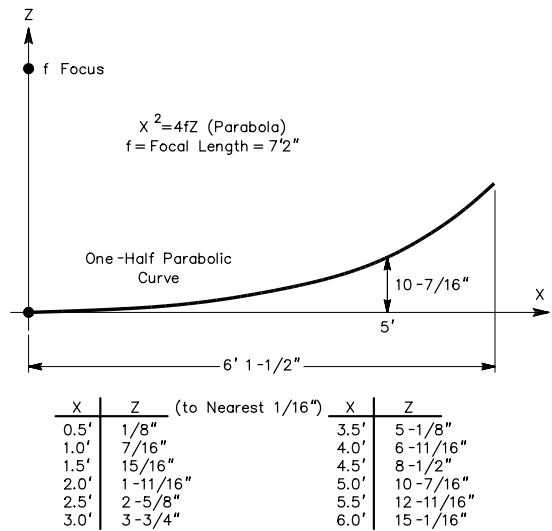
- 1) Joints of screening do not have to make electrical contact. The horizontal wires reflect the horizontal wave. Skew polarizations are merely a combination of horizontal and vertical components which are thus reflected by the corresponding wires of the screening. To a horizontally polarized wave, the spacing and diameter of only the horizontal wires determine the reflection coefficient (see Fig 34). Many amateurs have the mistaken impression that screening materials that do not make electrical contact at their junctions are poor reflectors.
- 2) By measuring wire diameter and spacings between the wires, a calculation of percentage of aperture that is filled can be made. This will be one of the major determining factors of wind pressure when the surfacing material is dry.



**Fig 33—Parabolic-antenna gain versus size, frequency, and surface errors. All curves assume 60% aperture efficiency and 10-dB power taper. Reference: J. Ruze, British IEE.**



**Fig 34—Surfacing material quality.**



**Fig 35—Parabolic template for 12-foot, 3-inch dish.**



Under ice and snow conditions, smaller aperture materials may become clogged, causing the surfacing material to act as a solid “sail.” Ice and snow have a rather minor effect on the reflecting properties of the surface, however.

- 3) Amateurs who live in areas where ice and snow are prevalent should consider a de-icing scheme such as weaving enameled wire through the screening and passing a current through it, fastening water-pipe heating tape behind the screening, or soldering heavy leads to the screening perimeter and passing current through the screening itself.

### A Parabolic Template

At and above 2300 MHz (where high surface accuracy is required), a parabolic template should be constructed to measure surface errors. A simple template may be constructed (see [Fig 35](#)) by taking a 12-foot 3-inch length of 4-foot wide tar paper and drawing a parabolic shape on it with chalk. The

points for the parabolic shape are calculated at 6-inch intervals and these points are connected with a smooth curve.

For those who wish to use the template with the surface material installed, the template should be cut along the chalk line and stiffened by cardboard or a wood lattice frame. Surface error measurements should take place with all spokes installed and deflected by the fishing lines, as some bending of the center plates does take place.

### Variations

All the possibilities of the stressed parabolic antenna have not been explored. For instance, a set of fishing lines or guy wires can be set up behind the dish for error correction, as long as this does not cause permanent bending of the aluminum spokes. This technique also protects the dish against wind loading from the rear. An extended piece of TV mast is an ideal place to hang a counterweight and attach the rear guys. This strengthens the structure considerably.

## The Helical Antenna

The axial-mode helical antenna was introduced by [Dr John Kraus, W8JK](#), in the 1940s. The material in this section was prepared by [Domenic Mallozzi, N1DM](#).

This antenna has two characteristics that make it especially interesting and useful in many applications. First, the helix is circularly polarized. As discussed earlier, circular polarization is simply linear polarization that continually rotates as it travels through space. In the case of a helical array, the rotation is about the axis of the antenna. This can be pictured as the second hand of a watch moving at the same rate as the applied frequency, where the position of the second hand can be thought of as the instantaneous polarization of the signal.

The second interesting property of the helical antenna is its predictable pattern, gain and impedance characteristics over a wide frequency range. This is one of the few antennas that has both broad bandwidth and high gain. The benefit of this property is that, when used for narrow-band applications, the helical antenna is very forgiving of mechanical inaccuracies.

Probably the most common amateur use of the helical antenna is in satellite communications, where the spinning of the satellite antenna system (relative to the earth) and the effects of Faraday rotation cause the polarization of the satellite signal to be unpredictable. Using a linearly polarized antenna in this situation results in deep fading, but with the helical antenna (which responds equally to linearly polarized signals), fading is essentially eliminated.

This same characteristic makes helical antennas useful in polarization diversity systems. The advantages of circular polarization have been demonstrated by [Bill Sykes, G2HCG](#), on VHF voice schedules over nonoptical paths, in cases

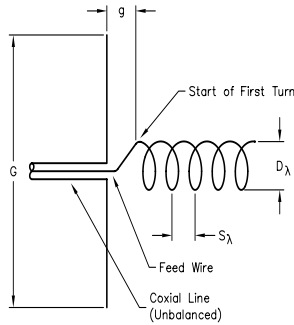
where linearly polarized beams did not perform satisfactorily. (See Bibliography.) An array of linear antennas was used to develop a circularly polarized radiation pattern in this case. The helix is also a good antenna for long-haul commercial TV reception.

Another use for the helical antenna is the transmission of color ATV signals. Many beam antennas (when adjusted for maximum gain) have far less bandwidth than the required 6 MHz, or have nonuniform gain over this frequency range. The result is significant distortion of the transmitted and received signals, affecting color reproduction and other features. This problem becomes more aggravated over nonoptical paths. The helix exhibits maximum gain (within 1 dB) over at least 6 MHz anywhere above 420 MHz.

The helical antenna can be used to advantage with multimode rigs, especially above 420 MHz. Not only does the helix give high gain over an entire amateur band, but it also allows operation on FM, SSB and CW without the need for separate vertically and horizontally polarized antennas.

### HELICAL ANTENNA BASICS

The helical antenna is an unusual specimen in the antenna world, in that its physical configuration gives a hint to its electrical performance. A helix looks like a large air-wound coil with one of its ends fed against a ground plane, as shown in [Fig 36](#). The ground plane is a screen of  $0.8 \lambda$  to  $1.1 \lambda$  diameter (or on a side for a square ground plane). The circumference ( $C_\lambda$ ) of the coil form must be between  $0.75 \lambda$  and  $1.33 \lambda$  for the antenna to radiate in the axial mode. The coil should have at least three turns to radiate in this mode. (It is possible, through special techniques, to make



$$C_\lambda = 0.75 \text{ to } 1.33 \lambda$$

$$S_\lambda = 0.2126 C_\lambda \text{ to } 0.2867 C_\lambda$$

$$G = 0.8 \text{ to } 1.1 \lambda$$

$$g = 0.12 \text{ to } 0.13 \lambda$$

$$\text{AR (axial ratio)} = \frac{2n + 1}{2n}$$

$S_\lambda$  = axial length of one turn  
 $D_\lambda$  = diameter of winding  
 $G$  = ground plane diameter (or side length)  
 $g$  = ground plane to first turn distance  
 $C_\lambda = \pi D_\lambda$  = circumference of winding  
 $n$  = number of turns  
 Gain (dBi) =  $11.8 + 10 \log(C_\lambda^2 n S_\lambda)$

$$\text{Half power beamwidth (HPBW)} = \frac{52}{C_\lambda \sqrt{n S_\lambda}} \text{ degrees}$$

$$\text{Beamwidth to first nulls} = \frac{115}{C_\lambda \sqrt{n S_\lambda}} \text{ degrees}$$

Input impedance =  $140 C_\lambda$  ohms  
 $L_\lambda$  = length of conductor in one turn

$$= \sqrt{(\pi D_\lambda)^2 + S_\lambda^2}$$

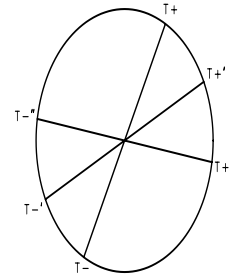
**Fig 36—The basic helical antenna and design equations.**

axial-mode helicals with as little as one turn.) The ratio of the spacing between turns (in wavelengths),  $S_\lambda$  to  $C_\lambda$ , should be in the range of 0.2126 to 0.2867. This ratio range results from the requirement that the pitch angle,  $\alpha$ , of the helix be between  $12^\circ$  and  $16^\circ$ , where

$$\alpha = \arctan \frac{S_\lambda}{C_\lambda}$$

These constraints result in a single main lobe along the axis of the coil. This is easily visualized from **Fig 37**. Assume the winding of the helix comes out of the page with a clockwise winding direction. (The winding can also be a counterclockwise—this results in the opposite polarization sense.)

A helix with a  $C_\lambda$  of  $1 \lambda$  has a wave propagating from one end of the coil (at the ground plane). The “peak” (+) of the wave appears opposite the “valley” (−) of the wave. This corresponds to a dipole “across” the helix—with the same



**Fig 37—A helical antenna with an axial ratio of 1.0 produces pure circular polarization. See text.**

polarization as the instantaneous polarization of the helix at time T.

At a later time ( $T'$ ), the “peak” and “valley” of the wave are at a slightly different angle relative to the original dipole. The polarization of the dipole antenna at this instant is slightly different. At an instant of time later yet ( $T''$ ), the dipole has again “moved,” changing the polarization slightly again.

The electrical rotation of this dipole produces circularly polarized radiation. Because the wave is moving along the helix conductor at nearly the speed of light, the rotation of the electrical dipole is at a very high rate. True circular polarization results.

Physicists and engineers formerly had opposite terms for the same sense of polarization. Recently, the definition of polarization sense used by the Institute of Electrical and Electronic Engineers (IEEE) has become the standard. The IEEE definition, in simple terms, is that when viewing the antenna from the feed-point end, a clockwise wind results in right-hand circular polarization, and a counterclockwise wind results in left-hand circular polarization. This is important, because when two stations use helical antennas *over a nonreflective path*, both must use antennas with the same polarization sense. If antennas of opposite sense are used, a signal loss of at least 30 dB results from the cross polarization alone.

As mentioned previously, circularly polarized antennas can be used in communications with any linearly polarized antenna (horizontal or vertical), because circularly polarized antennas respond equally to all linearly polarized signals. The gain of a helix is 3 dB less than the theoretical gain in this case, because the linearly polarized antenna does not respond to linear signal components that are orthogonally polarized relative to it.

The response of a helix to all polarizations is indicated by a term called *axial ratio*, also known as circularity. Axial ratio is the ratio of amplitude of the polarization that gives *maximum* response to the amplitude of the polarization that gives *minimum* response. An ideal circularly polarized antenna has an axial ratio of 1.0. A well-designed practical helix exhibits an axial ratio of 1.0 to 1.1. The axial ratio of a

helix is

$$AR = \frac{2n + 1}{2n}$$

where

AR = axial ratio

n = the number of turns in the helix

Axial ratio can be measured in two ways. The first is to excite the helix and use a linearly polarized antenna with an amplitude detector to measure the axial ratio directly. This is done by rotating the linearly polarized antenna in a plane perpendicular to the axis of the helix and comparing the maximum and minimum amplitude values. The ratio of maximum to minimum is the axial ratio.

Another method of measuring axial ratio was presented in 73 by [A. Bridges, WB4VXP](#). (See the Bibliography at the end of this chapter.) The linear antenna is replaced by two circularly polarized antennas of equal gain but opposite polarization sense. Taking the amplitude measurement with first one and then the other, the following equation is used to calculate axial ratio:

$$AR = \frac{E_{rcp} + E_{lcp}}{E_{rcp} - E_{lcp}}$$

where

$E_{rcp}$  is the voltage measured with the right-hand circularly polarized test antenna

$E_{lcp}$  is the voltage measured with the left-hand circularly polarized test antenna

This equation gives not only the axial ratio, but also indicates the polarization sense. If the result is greater than zero, the antenna being excited is right-hand circularly polarized, and left-hand if negative. This method is useful to those measuring other types of elliptically polarized antennas with polarization senses that are not easily determined.

The impedance of the helix is easily predictable. The terminal impedance of a helix is unbalanced, and is defined by

$$Z = 140 \times C_\lambda$$

where Z is the impedance of the helix in ohms.

The gain of a helical antenna is determined by its physical characteristics. Gain can be calculated from

$$\text{Gain (dBi)} = 11.8 + 10 \log (C_\lambda^2 n S_\lambda)$$

The beamwidth of the helical antenna (in degrees) at the half-power points is

$$BW = \frac{52}{C_\lambda \sqrt{n S_\lambda}}$$

The diameter of the helical antenna conductor should be between  $0.006 \lambda$  and  $0.05 \lambda$ , but smaller diameters have been used successfully at 144 MHz. The previously noted diameter of the ground plane ( $0.8$  to  $1.1 \lambda$ ) should not be exceeded if a clean radiation pattern is desired. As the ground

plane size is increased, the sidelobe levels also increase. (The ground plane need not be solid; it can be in the form of a spoked wheel or a frame covered with hardware cloth or poultry netting.)

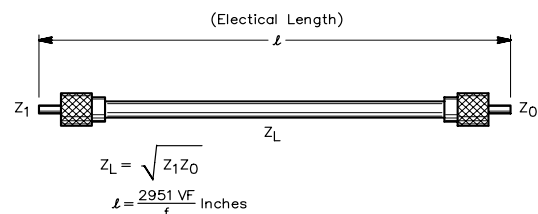
## MATCHING SYSTEMS

Because helical antennas present impedances on the order of 110 to 180  $\Omega$ , the antenna must be matched for use with a 52- $\Omega$  transmission line. Matching systems for helical antennas are classified two ways: narrow band and wide band. Narrow band is generally recognized to represent bandwidths less than 25%. Narrow-band matching techniques are relatively straightforward; matching systems useful over the full frequency range of a helix are a bit more involved.

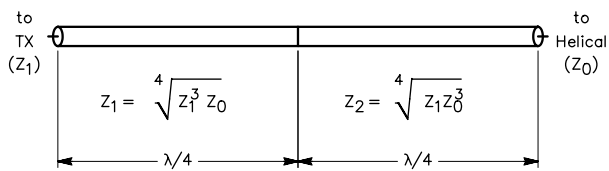
Many matching techniques are available. Some of the proven methods are discussed here. For narrow-band use, the simplest impedance-matching technique is the use of a  $1/4\text{-}\lambda$  series transformer. A  $1\text{-}\lambda$  circumference helix has a feed-point impedance of approximately 140  $\Omega$ , so the transformer must be  $1/4 \lambda$  of 84- $\Omega$  transmission line. This line can be fabricated in microstrip form, or a piece of air-dielectric coax can be built, as shown by [Doug DeMaw](#) in November 1965 *QST*. (See Bibliography.)

Another solution is to design the helix so that its feed-point impedance allows the use of a standard impedance line for the matching transformer. This method was shown by [D. Mallozzi](#) in the March 1978 *AMSAT Newsletter*. This helix was designed with a circumference of  $0.8 \lambda$ , resulting in an input impedance of 112  $\Omega$ . Standard 75- $\Omega$  coaxial cable can be used for the  $1/4\text{-}\lambda$  matching transformer in this case, as shown in **Fig 38**. Yet another matching method is to use a series section. For example, a 125- $\Omega$  helix may be matched to 52- $\Omega$  line by inserting  $0.125 \lambda$  of RG-133 (95- $\Omega$  impedance) in the 52- $\Omega$  line at a distance of  $0.0556 \lambda$  from the antenna feed point. Series section matching is discussed in **Chapter 26**.

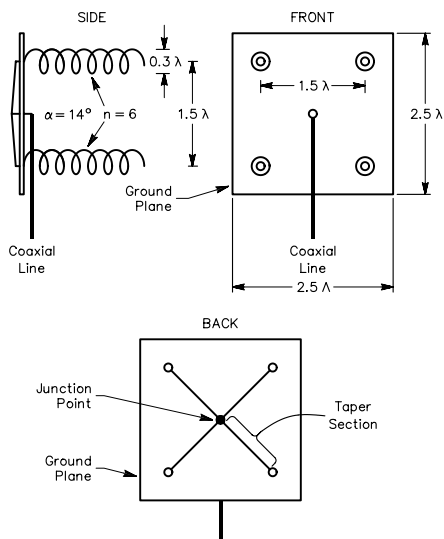
The physical construction of a  $1/4\text{-}\lambda$  transformer or a series section at UHF is a project requiring careful measurement and assembly. For narrow bandwidths at relatively low frequencies (below 148 MHz), the familiar pi network can be used for impedance matching to helical



**Fig 38—Narrow-band matching technique using a  $1/4\text{-}\lambda$  series transformer. In the length equation, VF = velocity factor of the cable; f = frequency, MHz.**



**Fig 39**—The dual series quarter-wave transformer is another means of matching 52-Ω coaxial cable to a helical antenna.



**Fig 40**—An array of four helicals on a common ground screen can provide as much gain as a single helix with four times as many turns as the individual helicals in the array. The benefits of this design include a cleaner radiation pattern and much smaller turning radius than a single long helix. See Fig 41 for detail of taper section.

antennas. Other matching methods are discussed in the references listed in the Bibliography at the end of this chapter.

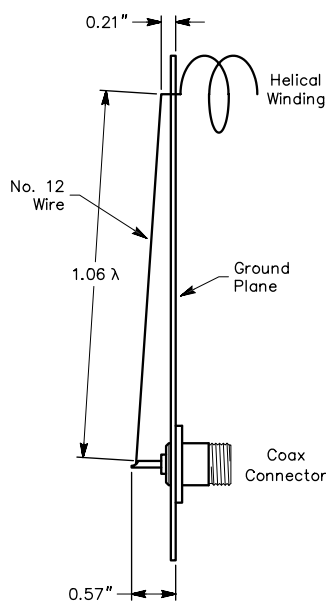
Two series transformers can be used to allow operation of a helical antenna over its entire bandwidth (see Fig 39). This method is in use in a number of helical antenna installations and provides good performance.

### SPECIAL CONFIGURATIONS

Many special helical antenna configurations have been developed. These special configurations usually address improvements in one or more of four areas:

- 1) Easing mechanical construction.
- 2) “Cleaning up” the radiation pattern (reducing sidelobes and backlobes), and increasing gain.
- 3) Maximizing bandwidth.
- 4) Improving terminal characteristics.

Increasing the bandwidth of a helical antenna is not usually required in amateur applications. Many of the professional journals listed in the Bibliography have



**Fig 41**—A diagram of one of the four tapered lines shown in Fig 40. This feed arrangement allows an array of four helicals to be fed directly with a 52-Ω line.

published articles discussing this subject, however. The other improvements listed all have applications in amateur work.

For example, the mechanical difficulty of making a helical antenna of the required diameter with the required conductor diameter is formidable at and below 148 MHz. Square or triangular winding forms are simpler than round forms at these frequencies. These configurations offer more mechanical stability under icing and wind conditions. Measurements indicate that if the perimeter of the form remains constant, it makes little difference in helical antenna characteristics if the cross-sectional shape is circular, square or triangular.

### Helical Antenna Variations

“Cleaning up” the radiation pattern (minimizing extraneous minor lobes) and increasing the gain of the helix can be done in a number of ways. The most common method of doing this is to mount three or four helical radiators on a single reflector and feed them in phase. This results in high gain with a cleaner radiation pattern than can be obtained with a single helical radiator having enough turns to obtain the same gain. Four 6-turn helicals mounted as shown in Fig 40 exhibit essentially the same gain as a single 24-turn helix. The turning radius of the quad array of helicals is smaller than the turning radius of a single helix of equal gain. The four elements are fed in parallel, using the feed method shown in Fig 41.

Another method of reducing extraneous lobes is to use the helix to excite a conical horn. This method is somewhat cumbersome mechanically, but is useful in situations where very clean radiation patterns are required.

Combining two “good” antennas can sometimes result in a single “better” antenna. This is the case when a helix is used to feed a parabolic dish. The high gain inherent in the

dish and the circular polarization afforded by the helix combine to make an excellent antenna for satellite and EME communications.

Such an antenna was built and tested at 465 MHz. The bandwidth was measured at more than 60 MHz. The antenna produces circular polarization with a sense opposite that of the feed helix. (The sense is reversed in reflection of the wave front from the parabolic surface.) This antenna is much easier to build than other types of circularly polarized dishes, because the mechanical construction of the feed is simpler.

This feed system is attractive to those who wish to use any of the common TVRO dishes that are available at reasonable cost. The gain of this combination at a given frequency is based on the illumination efficiency and size

of the dish used.

When using short helical antennas in a quad array for reception, wiring a series resistor of  $155 \Omega \frac{1}{4} \lambda$  from the open end of each helix improves the array performance. The sidelobe levels decrease, and matching and circularity (axial ratio) increase as a result of this modification. This performance improvement has been attributed to resistor dissipation of the unradiated energy reflected back toward the feed from the open end of the windings.

Publications such as *IEEE Transactions on Propagation and Antennas* and similar professional journals are a good source of information on the uses of helical antennas. University libraries often have these publications available for reference.

## A Switchable Sense Helical Antenna

Constructing a pair of helix antennas for the 435-MHz band is quite simple. One antenna is wound for RHCP, and the other for LHCP, as shown in Fig 42. A good UHF relay and some Hardline are all that is needed to complete the system. Inexpensive, readily available materials are used for construction, and the dimensions of the helicals are not critical. Fig 36 shows the helix formulas and dimensions.

This antenna has a 70% bandwidth, and is ideal for a high gain, broad beamwidth satellite tracking antenna. This switchable antenna system and 50 to 100 W of RF output yield respectable signals on the Phase III satellites.

A detail of the complicated portion of the helix is shown in Fig 43. Table 2 contains a keyed list of parts for the array. A good starting point for construction is the reflector, which is made of heavy wire mesh. This wire mesh is used in most UHF TV “bow tie” antennas. Wire companies and many hardware stores supply this material in 4-foot widths. It is 14-gauge galvanized steel, and sells for approximately \$1.60 to \$2 per lineal foot. A piece of mesh  $2 \times 4$  feet is required to build two antennas. Trim the mesh so that no sharp ends stick out.

The next step is to make the reflector mounting plates and boom brackets. Follow the dimensions shown in Fig 44. Heavy aluminum material is recommended; 0.060 inch is the minimum recommended thickness. Thicker material is more difficult to bend, but two bends of  $45^\circ$  spaced about  $\frac{1}{4}$  inch apart will work fine for the brackets in this case. The measurements shown are for TV type  $1\frac{3}{4}$  inch U bolts. If you use another size, change the dimensions appropriately. Drill the four holes in the reflector mounting plate and mount the coax receptacle, using pop rivets or stainless steel hardware.

Check the clearance between the coax receptacle and the elevation boom before final assembly. The thickness of the U-bolt spacers will affect this clearance. Mount a short piece of pipe (the same size as the elevation boom you will be using) to the U bolts, wire mesh reflector, reflector mounting plate and boom brackets. The elevation boom is

shown in Fig 43. Position the plate in the center of the wire mesh reflector. (It may be necessary to bend some of the mesh to clear the U bolts.) Finger tighten the U bolts so the plate can be adjusted to fit the mesh.

The wood boom assembly shown in Fig 43 consists of two 6-foot wooden tomato stakes joined by spacers in three places. Mount one spacer in the center and the other spacers 1 foot from each end. Notch the ends of the boom to fit into the mesh. When the correct alignment is obtained, clamp the assembly together and drill holes for rivets or bolts through the reflector mounting plate, brackets and wood boom assembly. When drilling the boom holes, place the

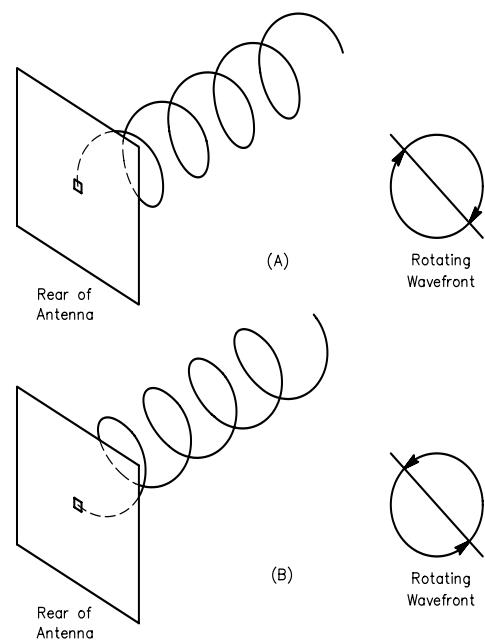
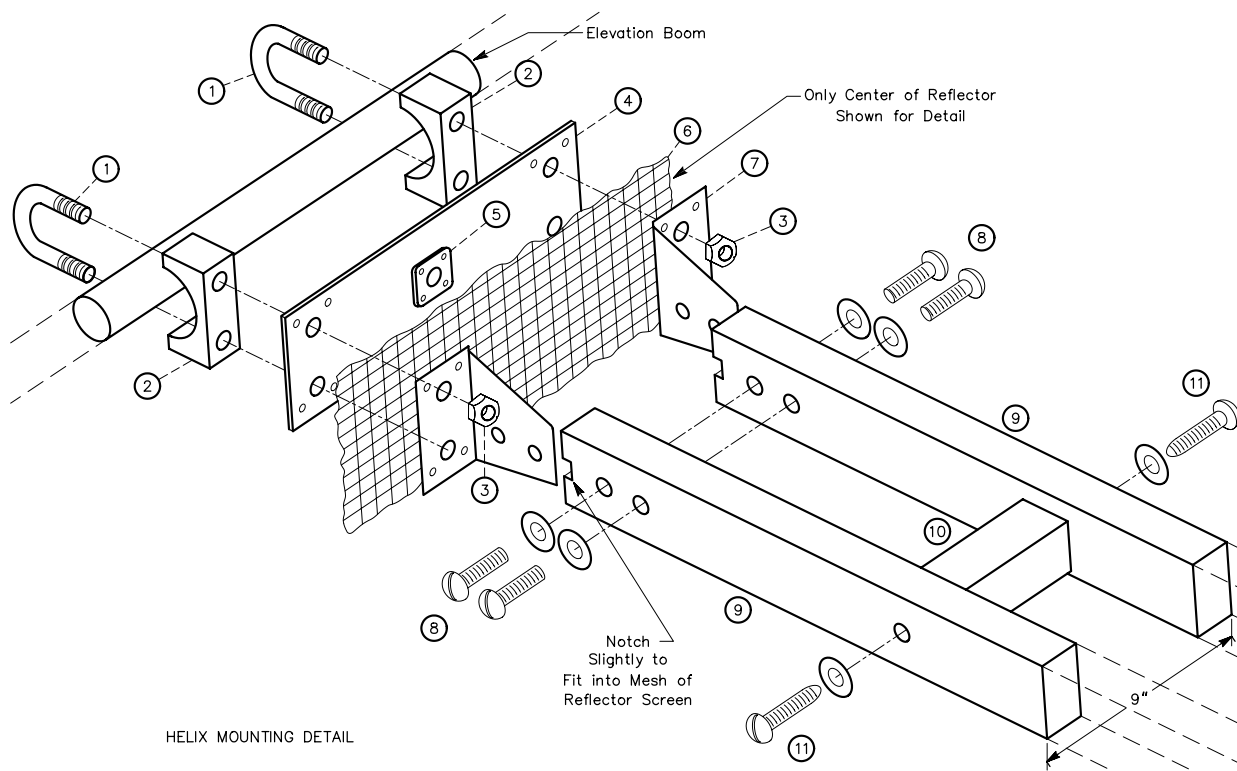


Fig 42—Right-hand circular polarization, A. Left-hand circular polarization, B.



**Fig 43—The details of the helix mounting arrangement. See Table 2 for a number-keyed parts list.**

**Table 2  
Parts List for the Helix Mounting Detail  
Shown in Fig 43**

<i>Piece</i>		
<i>No.</i>	<i>Description</i>	<i>Comments</i>
1	U bolt, TV type	Use to bolt antenna to elevation boom
2	U bolt spacer	As above
3	U bolt nut with lock washer	As above
4	Reflector mounting plate (see Fig 44)	Rivet through reflector to boom brackets
5	Type N coaxial receptacle	Rivet to mounting plate
6	1 × 2-inch heavy gauge wire mesh	Reflector, cut approx. 22 inches square
7	Helix boom-to-reflector brackets	Rivet through reflector to mounting plate
8	No. 8-32 bolts with nuts and washers	Bolt boom brackets to boom
9	Boom, approx. 1×1-inch tomato stake	2 pieces, 6 ft long.
10	Boom spacer, 1×1-inch	Boom to bolt; cut to give 9-inch spacing
11	No. 8 wood screws with washers	Attach spacers to boom (three places)

**Notes:**

- 1) Mount reflector mounting plate to boom brackets, leaving 9-in. clearance for boom.
- 2) Wire mesh may be bent to provide clearance for U bolts.
- 3) When positioning the reflector mounting plate, try to center the coaxial receptacle in the wire mesh screen.

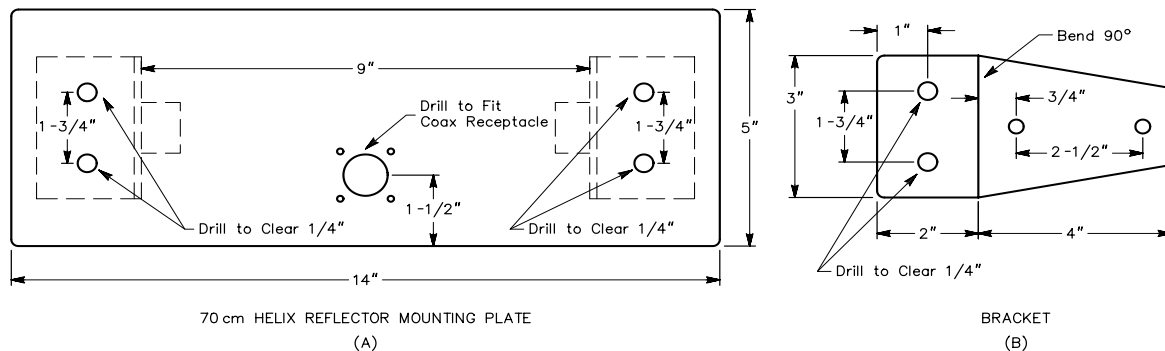
reflector flat on the floor and use a square so the boom is perpendicular to the reflector. Mark the boom through the holes in the boom bracket. When the assembly is complete, coat the wood boom with marine varnish.

The most unusual aspect of this antenna is its use of coaxial cable for the helix conductor. Coax is readily available, inexpensive, lightweight, and easy to shape into the coil required for the helix. Nine turns requires about 22 feet of cable, but start with 25 feet and trim off any excess. The antenna of Fig 45 uses FM-8 coaxial cable, but any coax that is near the 1/2-inch diameter required can be used. (The cable used must have a center conductor and shield that can be soldered together.)

Strip about 4 inches off one end of the cable down to the center conductor, but leave enough braid to solder to the center conductor. Solder the braid to the center conductor at this point. Measure the exposed center conductor 3.3 inches from the short and cut off the excess. (This is dimension g in Fig 36.)

Wind the 25-foot length of coax in a coil about 10 inches in diameter. Fig 42 shows which way to wind the coil for RHCP or LHCP. Slip the coil over the boom and move the stripped end of the cable toward the coax receptacle, which is the starting point of the nine turns. Solder the center conductor to the coax receptacle, and start the first turn 3.3 inches from the point of connection at the coax receptacle.

Use tie wraps to fasten the coax to the wood boom.



**Fig 44—At A, the helix reflector mounting plate (part no. 4 in Table 2). At B, the boom brackets (part no. 7 in Table 2).**

Mark the boom using dimension  $S_1$  in Fig 36. The first tie wrap is only half this distance when it first comes in contact with the boom; each successive turn on that side of the boom will be spaced by dimension  $S_1$ . Use two tie wraps so they form an X around the boom and coax. Once the first wrap is secure, wind each turn and fasten the cable one point at a time. Before each turn is tightened, make sure the dimensions are correct.

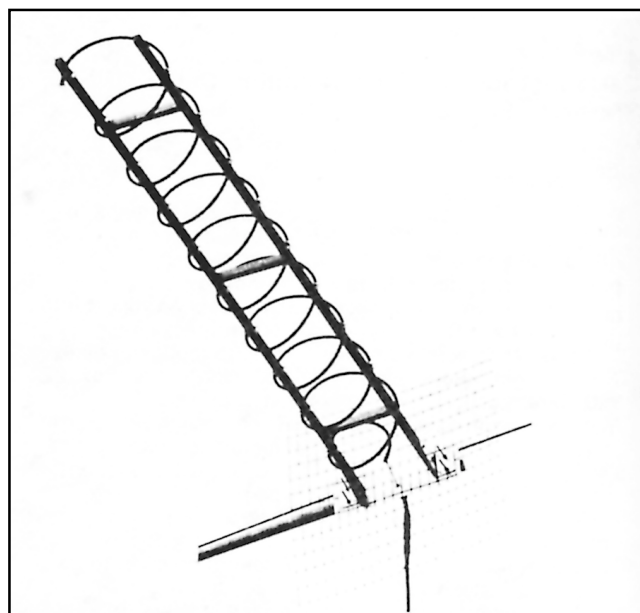
When all nine turns are wound, check all dimensions again. Cut the coax at the ninth turn, strip the end, and solder the braid to the center conductor. The exposed solder connections at each end of the coax conductor should be sealed to weatherproof them.

A coaxial 75- $\Omega$   $1/4$ - $\lambda$  matching section as shown in Fig 38 is connected in series with the feed line at the antenna feed point. The length of this cable (including connectors) is 4.5 inches if the cable used has a velocity factor of 0.66. Lengths for other types of cable can be calculated from the equation in the drawing.

The impedance of the helix is approximately 140  $\Omega$ . To match the 52- $\Omega$  transmission line, a transformer of 85.3  $\Omega$  is required. The 75- $\Omega$  cable used here is close enough to this value for a good match. The transformer should be connected directly to the female connector mounted on the reflector mounting plate. Use a double female adapter to connect the feed line to the matching transformer. Weatherproof the connectors appropriately.

To mount these antennas on an elevation boom, a counterbalance is required. The best way to do this is to mount an arm about 2 feet long to the elevation boom, at some point that is clear of the rotator, mast and other antennas. Point the arm away from the direction the helicals are pointing, and add weight to the end of the arm until balance is obtained. The completed antenna is shown in Fig 45.

Do not run long lengths of coax to this antenna, unless you use Hardline. Even short runs of good RG-8 coax are quite lossy; 50 feet of foam dielectric RG-8 has a loss of 2 dB at 430 MHz. There are other options if you must make long runs and can't use Hardline. Some amateurs mount

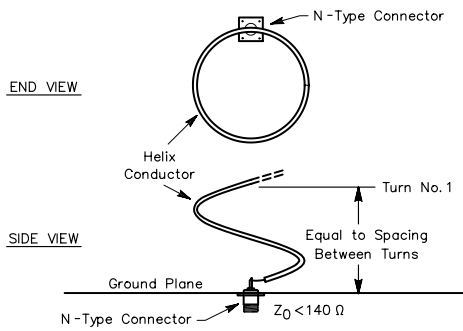


**Fig 45—A close-up view of the 435-MHz helical antenna, designed and built by Bernie Glassmeyer, W9KDR.**

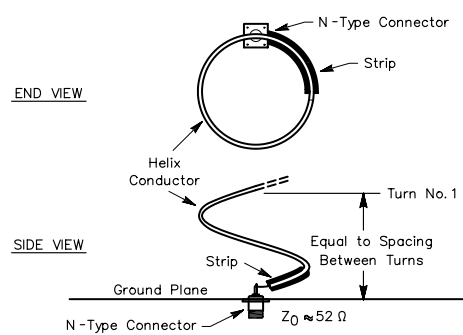
the converters, transverters, amplifiers and filters at the antenna. This can be easily done with the helix antenna; the units can be mounted behind the reflector. (This also adds counterweight.) If this approach is used, check local electrical codes before running any power lines to the antenna.

### 52- $\Omega$ HELIX FEED

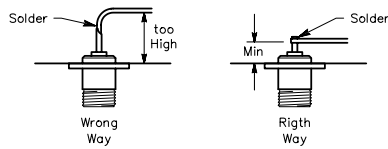
Joe Cadwallader, K6ZMW, presented this feed method in June 1981 *QST*. Terminate the helix in an N connector mounted on the ground screen *at the periphery of the helix* (Fig 46). Connect the helix conductor to the N connector as close to the ground screen as possible (Fig 47). Then adjust the first turn of the helix to maintain uniform spacing of the turns.



**Fig 46—End view and side view of peripherally fed helix.**



**Fig 48—End view and side view of peripherally fed helix with metal strip added to improve transformer action.**



**Fig 47—Wrong and right ways to attach helix to a type N connector for 52-Ω feed.**

This modification goes a long way toward curing a deficiency of the helix—the 140-Ω nominal feed-point impedance. The traditional  $\frac{1}{4}\lambda$ -matching section has proved difficult to fabricate and maintain. But if the helix is fed at the periphery, the first half turn of the helix conductor (leaving the N connector) acts much like a transmission line—a single conductor over a perfectly conducting ground plane. The impedance of such a transmission line is

$$Z_0 = 138 \log \frac{4h}{d}$$

where

$Z_0$  = line impedance in ohms

$h$  = height of the center of the conductor above the ground plane

$d$  = conductor diameter (in the same units as  $h$ ).

The impedance of the helix is 140 Ω a turn or two away

from the feed point. But as the helix conductor swoops down toward the feed connector (and the ground plane),  $h$  gets smaller, so the impedance decreases. The 140-Ω nominal impedance of the helix is transformed to a lower value. For any particular conductor diameter, an optimum height can be found that will produce a feed-point impedance equal to 52 Ω. The height should be kept very small, and the diameter should be large. Apply power to the helix and measure the SWR at the operating frequency. Adjust the height for an optimum match.

Typically, the conductor diameter may not be large enough to yield a 52-Ω match at practical (small) values of  $h$ . In this case, a strip of thin brass shim stock or flashing copper can be soldered to the first quarter turn of the helix conductor (Fig 48). This effectively increases the conductor diameter, which causes the impedance to decrease further yet. The edges of this strip can be slit every  $\frac{1}{2}$  inch or so, and the strip bent up or down (toward or away from the ground plane) to tune the line for an optimum match.

This approach yields a perfect match to nearly any coax. The usually wide bandwidth of the helix (70% for less than 2:1 SWR) will be reduced slightly (to about 40%) for the same conditions. This reduction is not enough to be of any consequence for most amateur work. The improvements in performance, ease of assembly and adjustment are well worth the effort in making the helix more practical to build and tune.



# Portable Helix for 435 MHz

Helicals for 435 MHz are excellent uplink antennas for Mode B satellite communications. The true circular polarization afforded by the helix minimizes signal “spin fading” that is so predominant in these operations. The antenna shown in **Fig 49** fills the need for an effective portable uplink antenna for OSCAR operation. Speedy assembly and disassembly and light weight are among the benefits of this array. This antenna was designed by Jim McKim, W0CY.

As mentioned previously, the helix is about the most tolerant of any antenna in terms of dimensions. The dimensions given here should be followed as closely as possible, however. Most of the materials specified are available in any well supplied “do it yourself” hardware or building supply store. The materials required to construct the portable helix are listed in **Table 3**.

The portable helix consists of eight turns of 1/4-inch soft copper tubing spaced around a 1-inch fiberglass tube or maple dowel rod 4 feet 7 inches long. Surplus aluminum jacket Hardline can be used in lieu of the copper tubing if necessary. The turns of the helix are supported by 5-inch lengths of 1/4-inch maple dowel that are mounted through the 1-inch rod in the center of the antenna. **Fig 50A** shows the overall dimensions of the antenna. Each of these support dowels has a V shaped notch in the end to locate the tubing (see **Fig 50B**).

The rod in the center of the antenna terminates at the feed-point end in a 4-foot piece of 1-inch ID galvanized steel pipe. The pipe serves as a counterweight for the heavier end of the antenna (that with the helical winding). The 1-inch rod material that is inside the helix must be nonconductive. Near the point where the nonconductive rod and the steel pipe are joined, a piece of aluminum screen or hardware cloth is used as a reflector screen.

If you have trouble locating the 1/4-inch soft copper tubing, try a refrigeration supply house. The perforated aluminum screening can be cut easily with tin snips. This material is usually supplied in 30 × 30-inch sheets, making this size convenient for a reflector screen. Galvanized 1/4-inch hardware cloth or copper screen could also be used for the screen, but aluminum is lighter and easier to work with.

A 1/8-inch thick aluminum sheet is used as the support plate for the helix and the reflector screen. Surplus rack panels provide a good source of this material. **Fig 51** shows the layout of this plate.

**Fig 52** shows how aluminum channel stock is used to support the reflector screen. (Aluminum tubing also works well for this. Discarded TV antennas provide plenty of this material if the channel stock is not available.) The screen is mounted on the bottom of the 10-inch aluminum center plate. The center plate, reflector screen and channel stock are connected together with plated hardware or pop rivets. This support structure is very sturdy.



**Fig 49—The portable 435-MHz helix, assembled and ready for operation. (W0CY photo)**

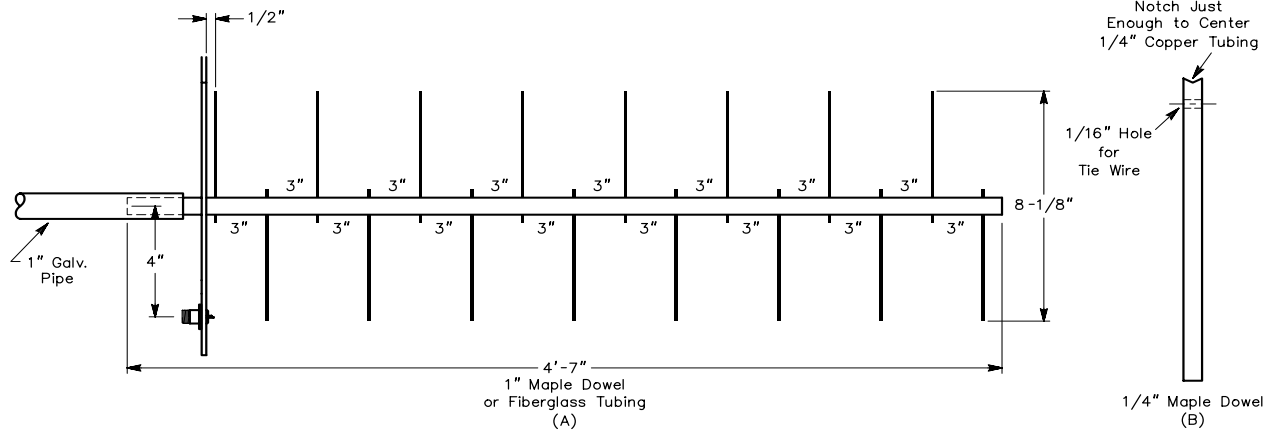
**Table 3**

## Parts List for the Portable 435-MHz Helix

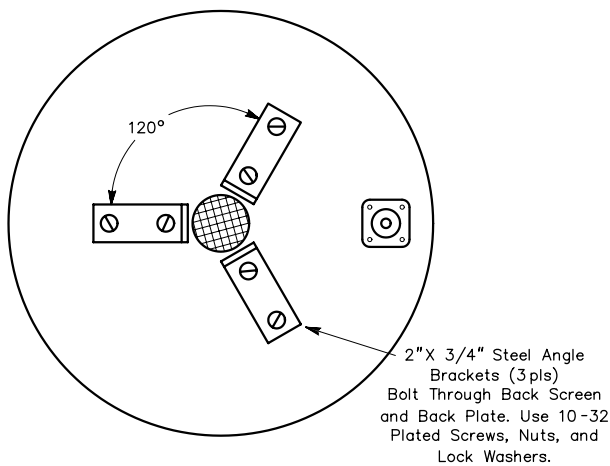
Qty	Item
1	Type N female chassis mount connector
18 ft	1/4-in. soft copper tubing
4 ft	1-in. ID galvanized steel pipe
1	5 ft × 1-in. fiberglass tube or maple dowel
14	5-in. pieces of 1/4-in. maple dowel (6 ft total)
1	1/8-in. aluminum plate, 10 in. diameter
3	2 × 3/4-in. steel angle brackets
1	30 × 30-in. (round or square) aluminum screen or hardware cloth
8 ft	1/2 × 1/2 × 1/2-in. aluminum channel stock or old TV antenna element stock
3	Small scraps of Teflon or polystyrene rod (spacers for first half turn of helix)
1	1/8 × 5 × 5-in. aluminum plate (boom to mast plate)
4	1 1/2-in. U bolts (boom to mast mounting)
3 ft	#22 bare copper wire (helix turns to maple spacers)

Assorted hardware for mounting connector, aluminum plate and screen, etc.

Fiberglass tubing is the best choice for the center rod material. Maple dowel can be used, but is generally not available in lengths over 3 feet. If maple must be used, the dowels can be spliced together by drilling holes in the center of each end and inserting a short length of smaller dowel into one of them. One of the large dowel ends should be notched, and the end of the other cut in a chisel shape so that they fit together. The small dowel can then be epoxied into both ends when they are fitted together. **Fig 53** illustrates this method of splicing dowels. The splice in the dowels



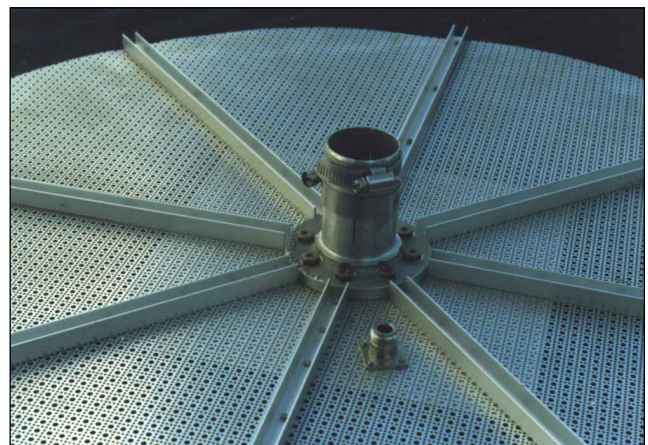
**Fig 50**—At A, the layout of the portable 435-MHz helix is shown. Spacing between the first 5-inch winding-support dowel and the ground plane is  $\frac{1}{2}$  inch; all other dowels are spaced 3 inches apart. At B, the detail of notching the winding-support dowels to accept the tubing. As indicated, drill a  $\frac{1}{16}$ -inch hole below the notch for a piece of small wire to hold the tubing in place.



**Fig 51**—The ground plane and feed-point support assembly. The circular piece is a 10-inch diameter,  $\frac{1}{8}$ -inch thick piece of aluminum sheet. (A square plate may be used instead.) Three  $2 \times \frac{3}{4}$ -inch angle brackets are bolted through this plate to the back side of the reflector screen to support the screen on the pipe. The type N female chassis connector is mounted in the plate four inches from the 1-inch diameter center hole.

should be placed as far from the center plate as possible to minimize stress on the connection.

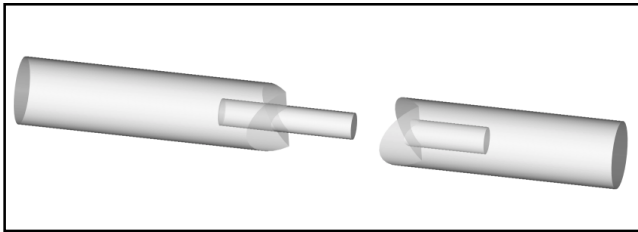
Mount the type N connector on the bottom of the center plate with the appropriate hardware. The center pin should be exposed enough to allow a flattened end of the copper tubing to be soldered to it. Tin the end of the tubing after it is flattened so that no moisture can enter it. If the helix is to be removable from the ground-plane screen, do not solder the copper tubing to the connector. Instead, prepare a small block of brass, drilled and tapped at one side for a



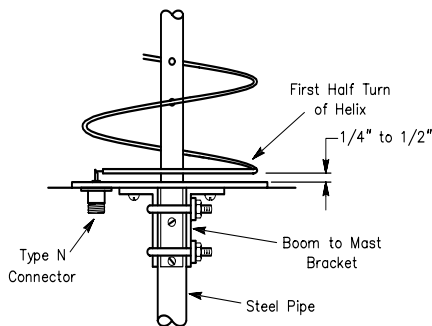
**Fig 52**—The method of reinforcing the reflector screen with aluminum channel stock. In this version of the antenna, the three angle brackets of Fig 51 have been replaced with a surplus aluminum flange assembly. (WOCY photo)

no. 6-32 screw. Drill another hole in the brass block to accept the center pin of the type N connector, and solder this connection. Now the connection to the copper tubing helix can be made in the field with a no. 6-32 screw instead of with a soldering iron.

Refer to Fig 50A. Drill the fiberglass or maple rod at the positions indicated to accept the 5-inch lengths of  $\frac{1}{2}$ -inch dowel. (If maple doweling is used, the wood must be weatherproofed as described below before drilling.) Drill a  $\frac{1}{16}$ -inch hole near the notch of each 5-inch dowel to accept a piece of #22 bare copper wire. (The wire is used to keep the copper tubing in place in the notch.) Sand the ends of the 5-inch dowels so the glue will adhere properly, and epoxy



**Fig 53—Close-up view of the dowel-splicing method. One dowel is notched, and the other is cut in a wedge shape to fit into the notch. Before this is done, both ends are drilled to accept a small piece of dowel (1/4 inch), which is glued into one of the ends. The large dowels should both be weatherproofed before splicing.**



**Fig 54—Side view of the helix feed-point assembly. The first half turn of the helix should be kept between 1/4 and 1/2 inch above the ground screen during winding. The height above the screen is adjusted for optimum match to a 52-Ω transmission line after the antenna is completed.**

them into the main support rod.

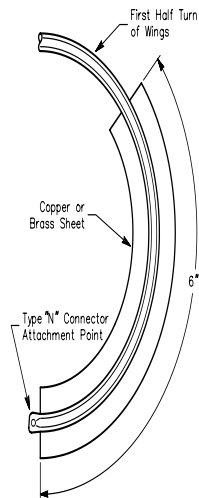
Begin winding the tubing in a clockwise direction from the reflector screen end. First drill a hole in the flattened end of the tubing to fit over the center pin of the type N connector. Solder it to the connector, or put the screw into the brass block described earlier. Carefully proceed to bend the tubing in a circular winding from one support to the next.

**Fig 54** shows how the first half turn of the helix tubing must be positioned about 1/4 inch above the reflector assembly. It is important to maintain this spacing, as extra capacitance between the tubing and ground is required for impedance-matching purposes.

Insert a piece of #22 copper wire in the hole in each support as you go. Twist the wire around the tubing and the support dowel. Solder the wire to the tubing and to itself to keep the tubing in the notches. Continue in this way until all eight turns have been wound. After winding the helix, pinch the far end of the tubing together and solder it closed.

### Weatherproofing the Wood

A word about preparing the maple doweling is in order. Wood parts must be protected against the weather to ensure long service life. A good way to protect wood is to boil it in paraffin for about half an hour. Any holes to be drilled in the



**Fig 55—If the match to the antenna cannot be obtained with the tubing alone, a 6-inch piece of copper flashing material can be soldered to the bottom of the first turn of the helix, starting very close to the feed point. The spacing can then be adjusted for best match as described in the text. When the appropriate spacing has been found, affix Teflon or polystyrene blocks between the screen and the winding with silicone sealant to maintain the spacing.**

wooden parts should be drilled *after* the paraffin is applied, as epoxy does not adhere well to wood after it has been coated with paraffin. The small dowels can be boiled in a saucepan. Caution must be exercised here—the wood can be scorched if the paraffin is too hot. Paraffin is sold for canning purposes at most grocery stores.

The center maple dowel is too long to put in a pan for boiling. A hair drier can be used to heat the long dowel, and paraffin can then be rubbed onto it. Heat the wood again to impregnate the surface with paraffin. This process should be repeated several times to ensure proper weatherproofing. Wood parts can also be protected with three or four coats of spar varnish. Each coat must be allowed to dry fully before another coat is applied.

The fiberglass tube or wood dowel must fit snugly with the steel pipe. The dowel can be sanded or turned down to the appropriate diameter on a lathe. If fiberglass is used, it can be coupled to the pipe with a piece of wood dowel that fits snugly inside the pipe and the tubing. Epoxy the dowel splice into the pipe for a permanent connection.

Drill two holes through the pipe and dowel and bolt them together. The pipe provides a solid mount to the boom of the rotator, as well as most of the weight needed to counter-balance the antenna. More weight can be added to the pipe if the assembly is “front-heavy.” (Cut off some of the pipe if the balance is off in the other direction.)

The helix has a nominal impedance of about 105 Ω in this configuration. By varying the spacing of the first half

turn of tubing, a good match to 52- $\Omega$  coax should be obtainable. If the SWR cannot be brought below about 1.5:1, a 6-inch length of copper flashing material can be added to the first half turn of the helix, as shown in Fig 55. The flashing material should be added as close to the coaxial cable connector as possible.

When the spacing has been established for the first half turn to provide a good match, add pieces of polystyrene or Teflon rod stock between the tubing and the reflector assembly to maintain the spacing. These can be held in place on the reflector assembly with silicone sealant. Be sure to seal the type N connector with the same material.

## BIBLIOGRAPHY

Source material and more extended discussion of the topics covered in this chapter can be found in the references given below and in the textbooks listed at the end of Chapter 2.

- W. Allen, "A Mode J Helix," *AMSAT Newsletter*, Jun 1979, pp 30-31.
- D. J. Angelakos and D. Kajfez, "Modifications on the Axial-Mode Helical Antenna," *Proc. IEEE*, Apr 1967, pp 558-559.
- J. Bartlett, "An Accurate, Low-Cost Antenna Elevation System," *QST*, Jun 1979, pp 19-22.
- J. Bartlett, "A Radio-Compass Antenna-Elevation Indicator," *QST*, Sep 1979, pp 24-25.
- A. L. Bridges, "Really Zap OSCAR With this Helical Antenna," 73, in three parts, Jul, Aug and Sep 1975.
- K. R. Carver, "The Helicone—A Circularly Polarized Antenna with Low Sidelobe Level," *Proc. IEEE*, Apr 1967, p 559.
- M. R. Davidoff, "A Simple 146-MHz Antenna for Oscar Ground Stations," *QST*, Sep 1974, pp 11-13.
- M. R. Davidoff, *The Radio Amateur's Satellite Handbook* (Newington, CT: ARRL, 1998-2000).
- D. DeMaw, "The Basic Helical Beam," *QST*, Nov 1965, pp 20-25, 170.
- D. Evans and G. Jessop, *VHF-UHF Manual*, 3rd ed. (London: RSGB), 1976.
- N. Foot, "WA9HUV 12-Foot Dish for 432 and 1296 MHz," *The World Above 50 Mc.*, *QST*, Jun 1971, pp 98-101, 107.
- N. Foot, "Cylindrical Feed Horn for Parabolic Reflectors," *Ham Radio*, May 1976.
- O. J. Glasser and J. D. Kraus, "Measured Impedances of Helical Beam Antennas," *Journal of Applied Physics*, Feb 1948, pp 193-197.
- H. E. Green, "Paraboidal Reflector Antenna with a Helical Feed," *Proc. IRE of Australia*, Feb 1960, pp 71-83.
- G. A. Hatherell, "Putting the G Line to Work," *QST*, Jun 1974, pp 11-15, 152, 154, 156.
- G. R. Isely and W. G. Smith, "A Helical Antenna for Space Shuttle Communications," *QST*, Dec 1984, pp 14-18.
- H. Jasik, *Antenna Engineering Handbook*, 1st ed. (New York: McGraw-Hill, 1961).
- R. T. Knadle, "A Twelve-Foot Stressed Parabolic Dish," *QST*, Aug 1972, pp 16-22.
- J. D. Kraus, "Helical Beam Antenna," *Electronics*, Apr 1947, pp 109-111.
- J. D. Kraus and J. C. Williamson, "Characteristics of Helical Antennas Radiating in the Axial Mode," *Journal of Applied Physics*, Jan 1948, pp 87-96.
- J. D. Kraus, "Helical Beam Antenna for Wide Band Applications," *Proc of the IRE*, Oct 1948, pp 1236-1242.
- J. D. Kraus, *Antennas* (New York: McGraw-Hill Book Co., 1950).
- J. D. Kraus, "A 50-Ohm Input Impedance for Helical Beam Antenna," *IEEE Transactions on Antennas and Propagation*, Nov 1977, p 913.
- J. D. Kraus, *Big Ear* (Powell, OH: Cygnus-Quasar Books, 1976).
- T. S. M. MacLean, "Measurements on High-Gain Helical Aerial and on Helicals of Triangular Section," *Proc. of IEE* (London), Jul 1964, pp 1267-1270.
- D. M. Mallozzi, "The Tailored Helical," *AMSAT Newsletter*, Mar 1978, pp 8-9.
- M. W. Maxwell, *Reflections—Transmission Lines and Antennas* (Newington, CT: ARRL, 1990) [out of print].
- T. Moreno, *Microwave Transmission Design Data* (New York: McGraw-Hill, 1948).
- K. Nose, "Crossed Yagi Antennas for Circular Polarization," *QST*, Jan 1973, pp 11-12.
- K. Nose, "A Simple Az-El Antenna System for Oscar," *QST*, Jun 1973, pp 11-12.
- C. Richards, "The 10 Turn Chopstick Helical (Mk2) for OSCAR 10 432 MHz Uplink," *Radio Communication*, Oct 1984, pp 844-845.
- S. Sander and D. K. Cheng, "Phase Center of Helical Beam Antennas," *IRE National Convention Record Part 6*, 1958, pp 152-157.
- E. A. Scott and H. E. Banta, "Using the Helical Antenna at 1215 Mc.," *QST*, Jul 1962, pp 14-16.
- G. Southworth, *Principles and Applications of Waveguide Transmission* (New York: D. Van Nostrand Co., 1950).
- B. Sykes, "Circular Polarization and Crossed-Yagi Antennas," *Technical Topics, Radio Communication*, Feb 1985, p 114.
- H. E. Taylor and D. Fowler, "A V-H-F Helical Beam Antenna," *CQ*, Apr 1949, pp 13-16.
- G. Tillitson, "The Polarization Diplexer—A Polaplexer," *Ham Radio*, Mar 1977.
- P. P. Viezbicke, "Yagi Antenna Design," *NBS Technical Note 688* (U. S. Dept. of Commerce/National Bureau of Standards, Boulder, CO), Dec 1976.
- D. Vilardi, "Easily Constructed Antennas for 1296 MHz," *QST*, Jun 1969.
- D. Vilardi, "Simple and Efficient Feed for Parabolic Antennas," *QST*, Mar 1973.
- J. L. Wong and H. E. King, "Broadband Quasi-Tapered Helical Antenna," *IEEE Transactions on Antennas and Propagation*, Jan 1979, pp 72-78.
- Radio Communication Handbook*, 5th ed. (London: RSGB, 1976).

# Antenna Materials and Accessories

This chapter contains information on materials amateurs use to construct antennas—what types of material to look for in a particular application, tips on working with and using various materials. [Chapter 21](#) contains information on where to purchase these materials.

Basically, antennas for MF, HF, VHF and the lower UHF range consist simply of one or more conductors that radiate (or receive) electromagnetic waves. However, an antenna system must also include some means to support those conductors and maintain their relative positions—the boom for a Yagi antenna and the

halyards for a wire dipole, for example. In this chapter we'll look at materials for those applications, too. Structural supports, such as towers, masts and poles, are discussed in [Chapter 22](#).

There are two main types of material used for antenna conductors, wire and tubing. Wire antennas are generally simple and therefore easier to construct, although some arrays of wire elements can become rather complex. When tubing is required, aluminum tubing is used most often because of its light weight. Aluminum tubing is discussed in a subsequent section of this chapter.

## Wire Antennas

Although wire antennas are relatively simple, they can constitute a potential hazard unless properly constructed. Antennas should never be run under or over public utility (telephone or power) lines. Several amateurs have lost their lives by failing to observe this precaution.

The National Electric Code® of the National Fire Protection Association contains a section on amateur stations in which a number of recommendations are made concerning minimum size of antenna wire and the manner of bringing the transmission line into the station. [Chapter 1](#) contains more information about this code. The code in itself does not have the force of law, but it is frequently made a part of local building regulations, which are enforceable. The provisions of the code may also be written into, or referred to, in fire and liability insurance documents.

The RF resistance of copper wire increases as the size of the wire decreases. However, in most types of antennas that are commonly constructed of wire (even quite small wire), the radiation resistance will be much higher than the RF resistance, and the efficiency of the antenna will still be adequate. Wire sizes as small as #30, or even smaller, have been used quite successfully in the construction of “invisible” antennas in areas where more conventional antennas cannot be erected. In most cases, the selection of wire for an antenna will be based primarily on the physical properties of the wire, since the suspension of wire from elevated supports places a strain on the wire.

### WIRE TYPES

Wire having an enamel coating is preferable to bare wire, since the coating resists oxidation and corrosion. Several types of wire having this type of coating are available, depending on the strength needed. “Soft-drawn” or annealed copper wire is easiest to handle; unfortunately, it stretches considerably under stress. Soft-drawn wire should be avoided, except for applications where the wire will be under little or no tension, or where some change in length can be tolerated. (For example, the length of a horizontal antenna fed at the center with open-wire line is not critical, although a change in length may require some readjustment of coupling to the transmitter.)

“Hard-drawn” copper wire or copper-clad steel wire (also known as Copperweld™) is harder to handle, because it has a tendency to spiral when it is unrolled. These types of wire are ideal for applications where significant stretch cannot be tolerated. Care should be exercised in using this wire to make sure that kinks do not develop—the wire will have a far greater tendency to break at a kink. After the coil has been unwound, suspend the wire a few feet above ground for a day or two before using it. The wire should not be recoiled before it is installed.

Several factors influence the choice of wire type and size. Most important to consider are the length of the unsupported span, the amount of sag that can be tolerated, the stability of the supports under wind pressure, and whether

or not an unsupported transmission line is to be suspended from the span. **Table 1** shows the wire diameter, current-carrying capacity and resistance of various sizes of copper wire. **Table 2** shows the maximum rated working tensions of hard-drawn and copper-clad steel wire of various sizes. These two tables can be used to select the appropriate wire size for an antenna.

### WIRE TENSION

If the tension on a wire can be adjusted to a known value, the expected sag of the wire (**Fig 1**) may be determined before installation using **Table 2** and the nomograph of **Fig 2**. Even though there may be no convenient method to determine the tension in pounds, calculation of the expected sag for practicable working tensions is often desirable. If the calculated sag is greater than allowable it may be reduced by any one or a combination of the following:

- 1) Providing additional supports, thereby decreasing the span
- 2) Increasing the tension in the wire if less than recommended
- 3) Decreasing the size of the wire

#### Instructions for Using the Nomograph

- 1) From **Table 2**, find the weight (pounds/1000 feet) for the particular wire size and material to be used.
- 2) Draw a line from the value obtained above, plotted on the weight axis, to the desired span (feet) on the span axis, **Fig 2**. Note in **Fig 1** that the span is one half the distance between the supports.

3) Choose an operating tension level (in pounds) consistent with the values presented in **Table 2** (preferably less than the recommended wire tension).

4) Draw a line from the tension value chosen (plotted on the tension axis) through the point where the work axis crosses the original line constructed in step 2, and continue this new line to the sag axis.

5) Read the sag in feet on the sag axis.

Example:

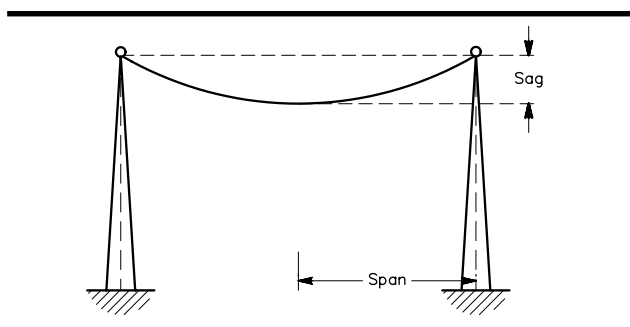
Weight = 11 pounds/1000 feet

Span = 210 feet

Tension = 50 pounds

Answer: Sag = 4.7 feet

These calculations do not take into account the weight of a feed line supported by the antenna wire.



**Fig 1—The span and sag of a long-wire antenna.**

**Table 1  
Copper-Wire Table**

Wire Size AWG (B&S)	Dia in Mils <sup>1</sup>	Dia in mm	Turns		Feet per Pound Bare	Ohms per 1000 ft 25°C	Cont.-duty current <sup>2</sup> Single Wire in Open Air	Wire Size AWG (B&S)	Dia in Mils <sup>1</sup>	Dia in mm	Turns		Feet per Pound Bare	Ohms per 1000 ft 25°C	Cont.-duty current <sup>2</sup> Single Wire in Open Air
			per Linear Inch Enamel	per Linear Inch Enamel							per Linear Inch Enamel	per Linear Inch Enamel			
1	289.3	7.348	—	3.947	0.1264	—	22	25.3	0.644	37.0	514.2	16.46	—		
2	257.6	6.544	—	4.977	0.1593	—	23	22.6	0.573	41.3	648.4	20.76	—		
3	229.4	5.827	—	6.276	0.2009	—	24	20.1	0.511	46.3	817.7	26.17	—		
4	204.3	5.189	—	7.914	0.2533	—	25	17.9	0.455	51.7	1031	33.00	—		
5	181.9	4.621	—	9.980	0.3195	—	26	15.9	0.405	58.0	1300	41.62	—		
6	162.0	4.115	—	12.58	0.4028	—	27	14.2	0.361	64.9	1639	52.48	—		
7	144.3	3.665	—	15.87	0.5080	—	28	12.6	0.321	72.7	2067	66.17	—		
8	128.5	3.264	7.6	20.01	0.6405	73	29	11.3	0.286	81.6	2607	83.44	—		
9	114.4	2.906	8.6	25.23	0.8077	—	30	10.0	0.255	90.5	3287	105.2	—		
10	101.9	2.588	9.6	31.82	1.018	55	31	8.9	0.227	101	4145	132.7	—		
11	90.7	2.305	10.7	40.12	1.284	—	32	8.0	0.202	113	5227	167.3	—		
12	80.8	2.053	12.0	50.59	1.619	41	33	7.1	0.180	127	6591	211.0	—		
13	72.0	1.828	13.5	63.80	2.042	—	34	6.3	0.160	143	8310	266.0	—		
14	64.1	1.628	15.0	80.44	2.575	32	35	5.6	0.143	158	10480	335	—		
15	57.1	1.450	16.8	101.4	3.247	—	36	5.0	0.127	175	13210	423	—		
16	50.8	1.291	18.9	127.9	4.094	22	37	4.5	0.113	198	16660	533	—		
17	45.3	1.150	21.2	161.3	5.163	—	38	4.0	0.101	224	21010	673	—		
18	40.3	1.024	23.6	203.4	6.510	16	39	3.5	0.090	248	26500	848	—		
19	35.9	0.912	26.4	256.5	8.210	—	40	3.1	0.080	282	33410	1070	—		
20	32.0	0.812	29.4	323.4	10.35	11									
21	28.5	0.723	33.1	407.8	13.05	—									

<sup>1</sup>A mil is 0.001 inch.

<sup>2</sup>Max wire temp of 212° F and max ambient temp of 135° F.

**Table 2**

**Stressed Antenna Wire**

American Wire Gauge	Recommended Tension <sup>1</sup> (pounds)		Weight (pounds per 1000 feet)	
	Copper-clad steel <sup>2</sup>	Hard-drawn copper	Copper-clad steel <sup>2</sup>	Hard-drawn copper
4	495	214	115.8	126.0
6	310	130	72.9	79.5
8	195	84	45.5	50.0
10	120	52	28.8	31.4
12	75	32	18.1	19.8
14	50	20	11.4	12.4
16	31	13	7.1	7.8
18	19	8	4.5	4.9
20	12	5	2.8	3.1

<sup>1</sup>Approximately one-tenth the breaking load. Might be increased 50% if end supports are firm and there is no danger of ice loading.

<sup>2</sup>Copperweld,™ 40% copper.

**Wire Splicing**

Wire antennas should preferably be made with unbroken lengths of wire. In instances where this is not feasible, wire sections should be spliced as shown in Fig 3. The enamel insulation should be removed for a distance of about 6 inches from the end of each section by scraping with a knife or rubbing with sandpaper until the copper underneath is bright. The turns of wire should be brought up tight around the standing part of the wire by twisting with broad-nose pliers.

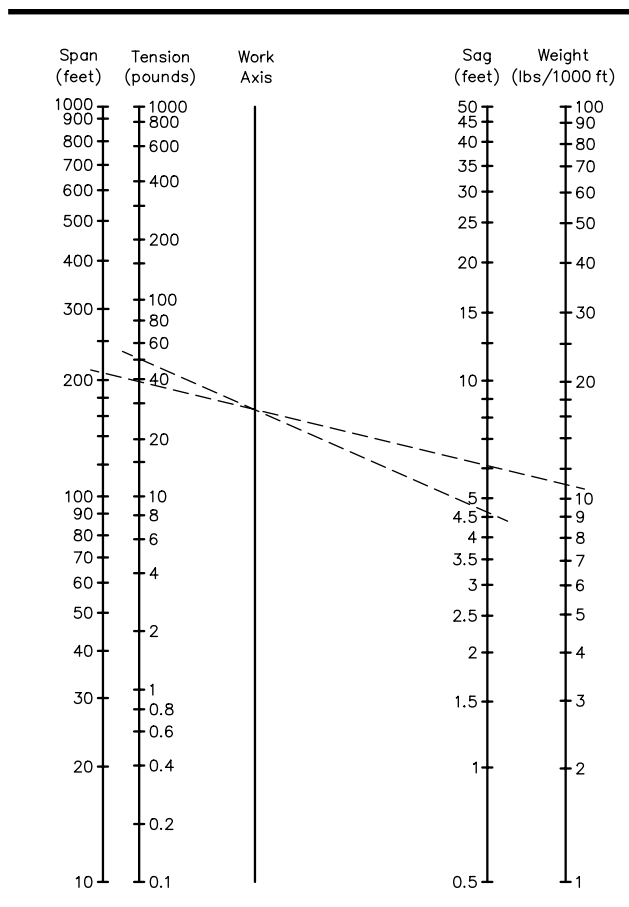
The crevices formed by the wire should be completely filled with rosin-core solder. An ordinary soldering iron or gun may not provide sufficient heat to melt solder outdoors; a propane torch is desirable. The joint should be heated sufficiently so the solder flows freely into the joint when the source of heat is removed momentarily. After the joint has cooled completely, it should be wiped clean with a cloth, and then sprayed generously with acrylic to prevent corrosion.

**ANTENNA INSULATION**

To prevent loss of RF power, the antenna should be well insulated from ground, unless of course it is a shunt-fed system. This is particularly important at the outer end or ends of wire antennas, since these points are always at a comparatively high RF potential. If an antenna is to be installed indoors (in an attic, for instance) the antenna may be suspended directly from the wood rafters without additional insulation, if the wood is permanently dry. Much greater care should be given to the selection of proper insulators when the antenna is located outside where it is exposed to wet weather.

**Insulator Leakage**

Antenna insulators should be made of material that will not absorb moisture. The best insulators for antenna use are made of glass or glazed porcelain. Depending on the type of material, plastic insulators may be suitable. The length of an insulator relative to its surface area is indicative of its comparative insulating ability. A long thin insulator will have



**Fig 2—Nomograph for determining wire sag. (John Elengo, Jr, K1AFR)**

less leakage than a short thick insulator. Some antenna insulators are deeply ribbed to increase the surface leakage path without increasing the physical length of the insulator. Shorter insulators can be used at low-potential points, such as at the center of a dipole. If such an antenna is to be fed

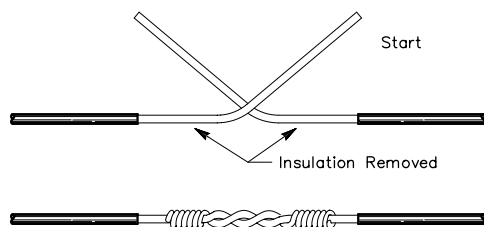
with open-wire line and used on several bands, however, the center insulator should be the same as those used at the ends, because high RF potential may exist across the center insulator on some bands.

### Insulator Stress

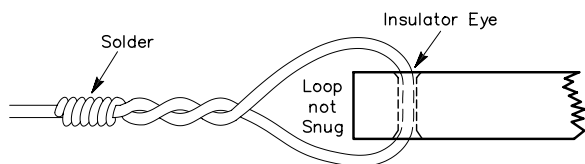
As with the antenna wire, the insulator must have sufficient physical strength to support the stress of the antenna without danger of breakage. Long elastic bands or lengths of nylon fishing line provide long leakage paths and make satisfactory insulators within their limits to resist mechanical strain. They are often used in antennas of the “invisible” type mentioned earlier.

For low-power work with short antennas not subject to appreciable stress, almost any small glass or glazed-porcelain insulator will do. Homemade insulators of Lucite rod or sheet will also be satisfactory. More care is required in the selection of insulators for longer spans and higher transmitter power.

For a given material, the breaking tension of an insulator will be proportional to its cross-sectional area. It should be remembered, however, that the wire hole at the end of the insulator decreases the effective cross-sectional area. For this reason, insulators designed to carry heavy strains are fitted with heavy metal end caps, the eyes being formed in the metal cap, rather than in the insulating material itself. The following



**Fig 3—Correct method of splicing antenna wire. Solder should be flowed into the wraps after the connection is completed. After cooling, the joint should be sprayed with acrylic to prevent oxidation and corrosion.**



**Fig 4—When fastening antenna wire to an insulator, do not make the wire loop too snug. After the connection is complete, flow solder into the turns. Then when the joint has cooled completely, spray it with acrylic.**

stress ratings of antenna insulators are typical:

$\frac{5}{8}$  in. square by 4 in. long—400 lb

1 in. diameter by 7 or 12 in. long—800 lb

$1\frac{1}{2}$  in. diameter by 8, 12 or 20 in. long, with special metal end caps—5000 lb

These are rated breaking tensions. The actual working tensions should be limited to not more than 25% of the breaking rating.

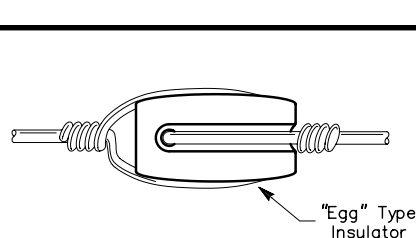
The antenna wire should be attached to the insulators as shown in **Fig 4**. Care should be taken to avoid sharp angular bends in the wire when it is looped through the insulator eye. The loop should be generous enough in size that it will not bind the end of the insulator tightly. If the length of the antenna is critical, the length should be measured to the outward end of the loop, where it passes through the eye of the insulator. The soldering should be done as described earlier for the wire splice.

### Strain Insulators

Strain insulators have their holes at right angles, since they are designed to be connected as shown in **Fig 5**. It can be seen that this arrangement places the insulating material under compression, rather than tension. An insulator connected this way can withstand much greater stress. Furthermore, the wire will not collapse if the insulator breaks, since the two wire loops are interlocked. Because the wire is wrapped around the insulator, however, the leakage path is reduced drastically, and the capacitance between the wire loops provides an additional leakage path. For this reason, the use of the strain insulator is usually confined to such applications as breaking up resonances in guy wires, where high levels of stress prevail, and where the RF insulation is of less importance. Such insulators might be suitable for use at low-potential points on an antenna, such as at the center of a dipole. These insulators may also be fastened in the conventional manner if the wire will not be under sufficient tension to break out the eyes.

### Insulators for Ribbon-Line Antennas

**Fig 6A** shows the sketch of an insulator designed to be used at the ends of a folded dipole or a multiple dipole made of ribbon line. It should be made approximately as shown, out of Lucite or bakelite material about  $\frac{1}{4}$  inch thick. The advantage of this arrangement is that the strain of the antenna



**Fig 5—Conventional manner of fastening wire to a strain insulator. This method decreases the leakage path and increases capacitance, as discussed in the text.**



is shared by the conductors and the plastic webbing of the ribbon, which adds considerable strength. After soldering, the screw should be sprayed with acrylic.

Fig 6B shows a similar arrangement for suspending one dipole from another in a stagger-tuned dipole system. If better insulation is desired, these insulators can be wired to a conventional insulator.

### PULLEYS AND HALYARDS

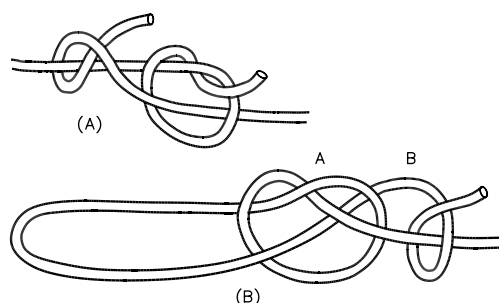
Pulleys and halyards commonly used to raise and lower a wire antenna must also be capable of taking the same strain as the antenna wire and insulators. Unfortunately, little specific information on the stress ratings of most pulleys is available. Several types of pulleys are readily available at almost any hardware store. Among these are small galvanized pulleys designed for awnings and several styles and sizes of clothesline pulleys. Heavier and stronger pulleys are those used in marine work. The factors that determine how much stress a pulley will handle include the diameter of the shaft, how securely the shaft is fitted into the sheath and the size and material of the frame.

Another important factor to be considered in the selection of a pulley is its ability to resist corrosion. Galvanized awning pulleys are probably the most susceptible to corrosion. While the frame or sheath usually stands up well, these pulleys usually fail at the shaft. The shaft rusts out, allowing the grooved wheel to break away under tension.

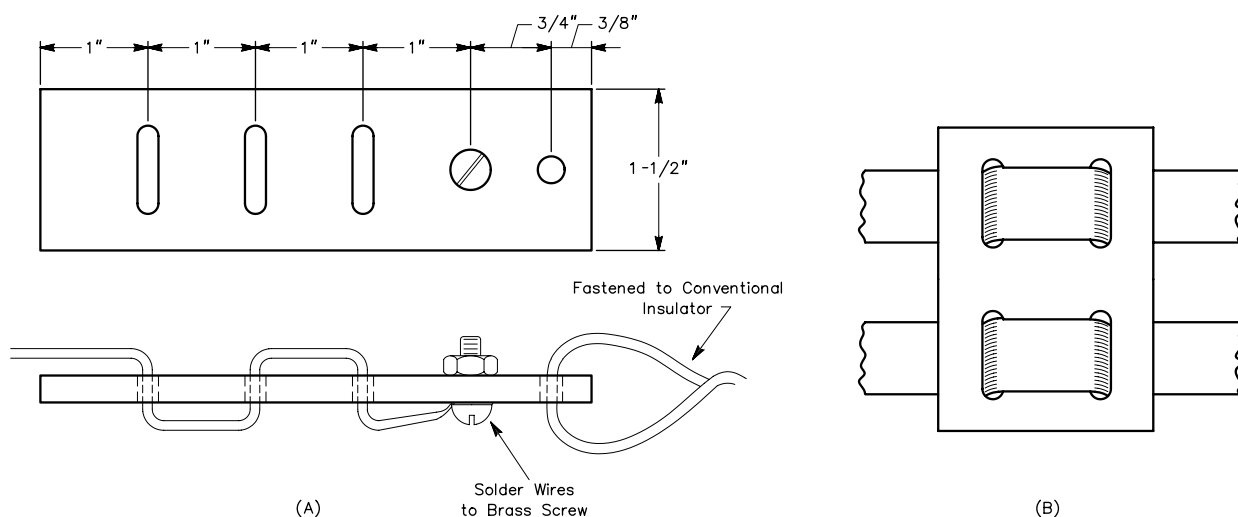
Most good-quality clothesline pulleys are made of alloys which do not corrode readily. Since they are designed to carry at least 50 feet of line loaded with wet clothing in stiff winds, they should be adequate for normal spans of 100 to 150 feet between stable supports. One type of

clothesline pulley has a 4-inch diameter plastic wheel with a 1/4-inch shaft running in bronze bearings. The sheath is made of cast or forged corrosion-proof alloy. Some look-alike low-cost pulleys of this type have an aluminum shaft with no bearings. For antenna work, these cheap pulleys are of little long-term value.

Marine pulleys have good weather-resisting qualities, since they are usually made of bronze, but they are comparatively expensive and are not designed to carry heavy loads. For extremely long spans, the wood-sheathed pulleys used in "block and tackle" devices and for sail hoisting should work well.



**Fig 7**—This is one type of knot that will hold with smooth rope, such as nylon. Shown at A, the knot for splicing two ends. B shows the use of a similar knot in forming a loop, as might be needed for attaching an insulator to a halyard. Knot A is first formed loosely 10 or 12 in. from the end of the rope; then the end is passed through the eye of the insulator and knot A. Knot B is then formed and both knots pulled tight. (Richard Carruthers, K7HDB)



**Fig 6**—At A, an insulator for the ends of folded dipoles, or multiple dipoles made of 300-ohm ribbon. At B, a method of suspending one ribbon dipole from another in a multiband dipole system.

## Halyards

**Table 3** shows the recommended maximum tensions for various sizes and types of line and rope suitable for hoisting halyards. Probably the best type for general amateur use for spans up to 150 or 200 feet is 1/4-inch nylon rope. Nylon is somewhat more expensive than ordinary rope of the same size, but it weathers much better. Nylon also has a certain amount of elasticity to accommodate gusts of wind, and is particularly recommended for antennas using trees as supports. A disadvantage of new nylon rope is that it stretches by a significant percentage. After an installation with new rope, it will be necessary to repeatedly take up the slack created by stretching. This process will continue over a period of several weeks, at which time most of the stretching will have taken place. Even a year after installation, however, some slack may still arise from stretching.

Most types of synthetic rope are slippery, and some types of knots ordinarily used for rope will not hold well. **Fig 7** shows a knot that should hold well, even in nylon rope or plastic line.

For exceptionally long spans, stranded galvanized steel sash cord makes a suitable support. Cable advertised as “wire rope” usually does not weather well. A boat winch, sold at marinas and at Sears, is a great convenience in antenna hoisting (and usually a necessity with metal halyards).

**Table 3**

### Approximate Safe Working Tension for Various Halyard Materials

<i>Material</i>	<i>Dia, In.</i>	<i>Tension, Lb</i>
Manila hemp rope	1/4	120
	3/8	270
	1/2	530
	5/8	800
Polypropylene rope	1/4	270
	3/8	530
	1/2	840
Nylon rope	1/4	300
	3/8	660
	1/2	1140
7×11 galvanized sash cord	1/16	30
	1/8	125
	3/16	250
	1/4	450
High-strength stranded galvanized steel guy wire	1/8	400
	3/16	700
	1/4	1200
Rayon-filled plastic clothesline	7/32	60 to 70

## Antennas of Aluminum Tubing

Aluminum is a malleable, ductile metal with a mass density of 2.70 grams per cubic centimeter. The density of aluminum is approximately 35% that of iron and 30% that of copper. Aluminum can be polished to a high brightness, and it will retain this polish in dry air. In the presence of moisture, aluminum forms an oxide coating (Al<sub>2</sub>O<sub>3</sub>) that protects the metal from further corrosion. Direct contact with certain metals, however (especially ferrous metals such as iron or steel), in an outdoor environment can bring about galvanic corrosion of aluminum and its alloys. Some protective coating should be applied to any point of contact between two dissimilar metals. Much of this information about aluminum and aluminum tubing was prepared by Ralph Shaw, K5CAV.

Aluminum is non-toxic; it is used in cooking utensils and to hold and cover “TV dinners” and other frozen foods, so it is certainly safe to work with. The ease with which it can be drilled or sawed makes it a pleasure to work with. Aluminum products lend themselves to many and varied applications.

Aluminum alloys can be used to build amateur antennas, as well as for towers and supports. Light weight and high conductivity make aluminum ideal for these applications. Alloying lowers the conductivity ratings, but

**Table 4**

### Aluminum Numbers for Amateur Use

<i>Type</i>	<i>Common Alloy Numbers</i>	<i>Characteristic</i>
2024		Good formability, high strength
5052		Excellent surface finish, excellent corrosion resistance, normally not heat treatable for high strength
6061		Good machinability, good weldability
6063		Good machinability, good weldability
7075		Good formability, high strength
	<i>Common Tempers</i>	<i>Characteristics</i>
T0		Special soft condition
T3		Hard
T6		Hardest, possibly brittle
TXXX		Three digit tempers—usually specialized high strength heat treatments, similar to T6
	<i>General Uses</i>	<i>Uses</i>
2024-T3		Chassis boxes, antennas, anything that will be bent or
7075-T3		Flexed repeatedly
6061-T6		Tubing and pipe; angle channel and bar stock
6063-T832		Tubing and pipe; angle channel and bar stock

**Table 5****Aluminum Tubing Sizes**

6061-T6 (61S-T6) Round Aluminum Tube in 12-Foot Lengths

Tubing Diameter	Wall Thickness		ID, Inches	Approximate Weight		Wall Thickness			Approximate Weight			
	Inches	Stubs Ga.		Pounds Per Foot	Pounds Per Length	Tubing Diameter	Inches	Stubs Ga.	ID, Inches	Pounds Per Foot	Pounds Per Length	
3/16 in.	0.035	(#20)	0.117	0.019	0.228	1 1/8 in.	0.035	(#20)	1.055	0.139	1.668	
	0.049	(#18)	0.089	0.025	0.330		0.058	(#17)	1.009	0.228	2.736	
1/4 in.	0.035	(#20)	0.180	0.027	0.324	1 1/4 in.	0.035	(#20)	1.180	0.155	1.860	
	0.049	(#18)	0.152	0.036	0.432		0.049	(#18)	1.152	0.210	2.520	
	0.058	(#17)	0.134	0.041	0.492		0.058	(#17)	1.134	0.256	3.072	
5/16 in.	0.035	(#20)	0.242	0.036	0.432	1 3/8 in.	0.065	(#16)	1.120	0.284	3.408	
	0.049	(#18)	0.214	0.047	0.564		0.083	(#14)	1.084	0.357	4.284	
	0.058	(#17)	0.196	0.055	0.660		0.035	(#20)	1.305	0.173	2.076	
3/8 in.	0.035	(#20)	0.305	0.043	0.516	1 1/2 in.	0.058	(#17)	1.259	0.282	3.384	
	0.049	(#18)	0.277	0.060	0.720		0.035	(#20)	1.430	0.180	2.160	
	0.058	(#17)	0.259	0.068	0.816		0.049	(#18)	1.402	0.260	3.120	
7/16 in.	0.065	(#16)	0.245	0.074	0.888	1 5/8 in.	0.058	(#17)	1.384	0.309	3.708	
	0.035	(#20)	0.367	0.051	0.612		0.065	(#16)	1.370	0.344	4.128	
	0.049	(#18)	0.339	0.070	0.840		0.083	(#14)	1.334	0.434	5.208	
1/2 in.	0.065	(#16)	0.307	0.089	1.068	1 3/4 in.	*0.125	1/8 in.	1.250	0.630	7.416	
	0.035	(#22)	0.444	0.049	0.588		*0.250	1/4 in.	1.000	1.150	14.832	
	0.035	(#20)	0.430	0.059	0.708		0.035	(#20)	1.555	0.206	2.472	
5/8 in.	0.049	(#18)	0.402	0.082	0.984	2 in.	0.058	(#17)	1.509	0.336	4.032	
	0.058	(#17)	0.384	0.095	1.040		0.058	(#17)	1.634	0.363	4.356	
	0.065	(#16)	0.370	0.107	1.284		0.083	(#14)	1.584	0.510	6.120	
3/4 in.	0.028	(#22)	0.569	0.061	0.732	2 1/4 in.	1 7/8 in.	0.058	(#17)	1.759	0.389	4.668
	0.035	(#20)	0.555	0.075	0.900		2 in.	0.049	(#18)	1.902	0.350	4.200
	0.049	(#18)	0.527	0.106	1.272		0.065	(#16)	1.870	0.450	5.400	
7/8 in.	0.058	(#17)	0.509	0.121	1.452	2 1/2 in.	0.083	(#14)	1.834	0.590	7.080	
	0.065	(#16)	0.495	0.137	1.644		*0.125	1/8 in.	1.750	0.870	9.960	
	0.035	(#20)	0.680	0.091	1.092		*0.250	1/4 in.	1.500	1.620	19.920	
5/8 in.	0.049	(#18)	0.652	0.125	1.500	3 in.	0.049	(#18)	2.152	0.398	4.776	
	0.058	(#17)	0.634	0.148	1.776		0.065	(#16)	2.120	0.520	6.240	
	0.065	(#16)	0.620	0.160	1.920		0.083	(#14)	2.084	0.660	7.920	
1 in.	0.083	(#14)	0.584	0.204	2.448	2 1/2 in.	0.065	(#16)	2.370	0.587	7.044	
	0.035	(#20)	0.805	0.108	1.308		0.083	(#14)	2.334	0.740	8.880	
	0.049	(#18)	0.777	0.151	1.810		*0.125	1/8 in.	2.250	1.100	12.720	
1 in.	0.058	(#17)	0.759	0.175	2.100	3 in.	*0.250	1/4 in.	2.000	2.080	25.440	
	0.065	(#16)	0.745	0.199	2.399		0.065	(#16)	2.870	0.710	8.520	
	0.049	(#18)	0.930	0.123	1.476		*0.125	1/8 in.	2.700	1.330	15.600	
1 in.	0.049	(#18)	0.902	0.170	2.040	3 in.	*0.250	1/4 in.	2.500	2.540	31.200	
	0.058	(#17)	0.884	0.202	2.424							
	0.065	(#16)	0.870	0.220	2.640							
1 in.	0.083	(#14)	0.834	0.281	3.372							

\*These sizes are extruded. All other sizes are drawn tubes.

the tensile strength can be increased by alloying aluminum with one or more metals such as manganese, silicon, copper, magnesium or zinc. Cold rolling can be employed to further increase the strength.

A four-digit system is used to identify aluminum alloys, such as 6061. Aluminum alloys starting with a 6 contain di-magnesium silicide (Mg<sub>2</sub>Si). The second digit indicates modifications of the original alloy or impurity limits. The last two digits designate different aluminum alloys within the category indicated by the first digit.

In the 6000 series, the 6061 alloy is a commonly used for antenna applications. Type 6061 has good resistance to corrosion and has medium strength. A further designation like T-6 denotes thermal treatment (heat tempering). More

information on the available aluminum alloys can be found in [Table 4](#).

**SELECTING ALUMINUM TUBING**

**Table 5** shows the standard sizes of aluminum tubing that are stocked by most aluminum suppliers or distributors in the United States and Canada. Note that all tubing comes in 12-foot lengths (local hardware stores sometimes stock 6- and 8-foot lengths). Note also that any diameter tubing will fit snugly into the next larger size, if the larger size has a 0.058-inch wall thickness. For example, 5/8-inch tubing has an outside diameter of 0.625 inch. This will fit into 3/4-inch tubing with a 0.058-inch wall, which has an inside diameter of 0.634 inch. A clearance of 0.009 inch is just

right for a slip fit or for slotting the tubing and then using hose clamps. Always get the next larger size and specify a 0.058-inch wall to obtain the 0.009-inch clearance.

A little figuring with [Table 5](#) will give you all the information you need to build a beam, including what the antenna will weigh. The 6061-T6 type of aluminum has a relatively high strength and has good workability. It is highly resistant to corrosion and will bend without taking a “set.”

### SOURCES FOR ALUMINUM

Aluminum can be purchased new, and suppliers are listed in [Chapter 21](#). But don’t overlook the local metal scrap yard. The price varies, but between 35 and 60 cents per pound is typical for scrap aluminum. Some aluminum items to look for include aluminum vaulting poles, tent poles, tubing and fittings from scrapped citizen’s band antennas, and aluminum angle stock. The scrap yard may even have a section or two of triangular aluminum tower.

Aluminum vaulting poles are 12 or 14 feet long and range in diameter from 1½ to 1¾ inches. These poles are suitable for the center-element sections of large 14-MHz beams or as booms for smaller antennas. Tent poles range in length from 2½ to 4 feet. The tent poles are usually tapered; they can be split on the larger end and then mated with the smaller end of another pole of the same diameter. A small stainless-steel hose clamp (sometimes also available at scrap yards!) can be used to fasten the poles at this junction. A 14- or 21-MHz element can be constructed from several tent poles in this fashion. If a longer continuous piece of tubing is available, it can be used for the center section to decrease the number of junctions and clamps.

Other aluminum scrap is sometimes available, such as US Army aluminum mast sections designated AB-85/GRA-4 (J&H Smith Mfg). These are 3 foot sections with a 1⅝ inch diameter. The ends are swaged so they can be assembled one into another. These are ideal for making a portable mast for a 144-MHz beam or for Field Day applications.

### CONSTRUCTION WITH ALUMINUM TUBING

Most antennas built for frequencies of 14 MHz and above are made to be rotated. Constructing a rotatable antenna requires materials that are strong, lightweight and easy to obtain. The materials required to build a suitable antenna will vary, depending on many factors. Perhaps the most important factor that determines the type of hardware needed is the weather conditions normally encountered. High winds usually don’t cause as much damage to an antenna as does ice, especially ice along with high winds. Aluminum element and boom sizes should be selected so the various sections of tubing will telescope to provide the necessary total length.

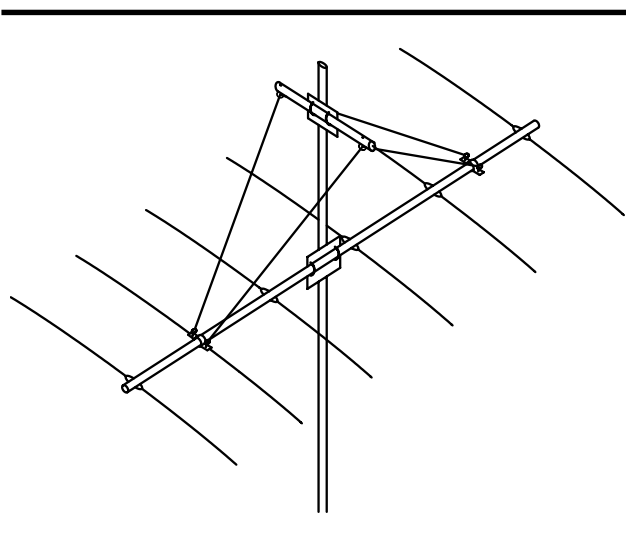
The boom size for a rotatable Yagi or quad should be selected to provide stability to the entire system. The best diameter for the boom depends on several factors; most important are the element weight, number of elements and overall length. Tubing of 1¼-inch diameter can easily support three-element 28-MHz arrays and perhaps a two-

element 21-MHz system. A 2-inch diameter boom will be adequate for larger 28-MHz antennas or for harsh weather conditions, and for antennas up to three elements on 14 MHz or four elements on 21 MHz. It is not recommended that 2-inch diameter booms be made any longer than 24 feet unless additional support is given to reduce both vertical and horizontal bending forces. Suitable reinforcement for a long 2-inch boom can consist of a truss or a truss and lateral support, as shown in [Fig 8](#).

A boom length of 24 feet is about the point where a 3-inch diameter begins to be very worthwhile. This dimension provides a considerable improvement in overall mechanical stability as well as increased clamping surface area for element hardware. Clamping surface area is extremely important if heavy icing is common and rotation of elements around the boom is to be avoided. Pinning an element to the boom with a large bolt helps in this regard. On smaller diameter booms, however, the elements sometimes work loose and tend to elongate the pinning holes in both the element and the boom. After some time the elements shift their positions slightly (sometimes from day to day!) and give a rather ragged appearance to the system, even though this doesn’t generally harm the electrical performance.

A 3-inch diameter boom with a wall thickness of 0.065 inch is satisfactory for antennas up to about a five-element, 14-MHz array that is spaced on a 40-foot long boom. A truss is recommended for any boom longer than 24 feet.

There is no RF voltage at the center of a parasitic element, so no insulation is required in mounting elements that are centered on the boom (driven elements excepted). This is true whether the boom is metal or a nonconducting material. Metal booms have a small “shortening effect” on elements that run through them. With materials sizes



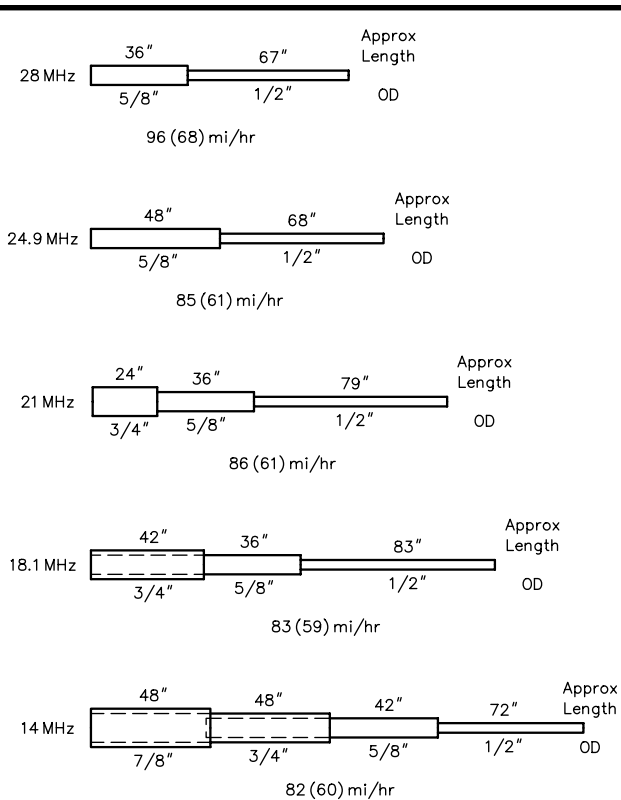
**Fig 8—A long boom needs both vertical and horizontal support. The cross bar mounted above the boom can support a double truss to help keep the antenna in position.**

commonly employed, this is not more than one percent of the element length, and may not be noticeable in many applications. It is just perceptible with 1/2-inch tubing booms used on 432 MHz, for example. Design-formula lengths can be used as given, if the matching is adjusted in the frequency range one expects to use. The center frequency of an all-metal array will tend to be 0.5 to 1 percent higher than a similar system built of wooden supporting members.

### Element Assembly

While the maximum safe length of an antenna element depends to some extent on its diameter, the only laws that specify the minimum diameter of an element are the laws of nature. That is, the element must be rugged enough to survive whatever weather conditions it will encounter.

**Fig 9** shows tapered Yagi element designs that will survive winds in excess of 80 mi/h. With a 1/4-inch thickness of radial ice, these designs will withstand winds up to approximately 60 mi/h. (Ice increases the wind area but does not increase the strength of the element.) More rugged



**Fig 9—Half-element designs for Yagi antennas. The other side of the element is identical, and the center section should be a single piece twice as long as the length shown here for the largest diameter section. Use 0.058-in.-wall aluminum tubing throughout. Broken lines indicate double tubing thickness, where one tube is inserted into another. The overlap insertion depth into a tube two sizes larger, where shown, should be at least two inches. Maximum survival wind speeds without ice are shown adjacent to each design; values enclosed in parentheses are survival speeds for 1/4 inch of radial ice.**

designs are shown in **Fig 10**. With no ice loading, these elements will survive in 120-mi/h winds, and in winds exceeding 85 mi/h with 1/4 inch of radial ice. If you lose an antenna made with elements like these, you'll have plenty of company among your neighbors with commercially made antennas!

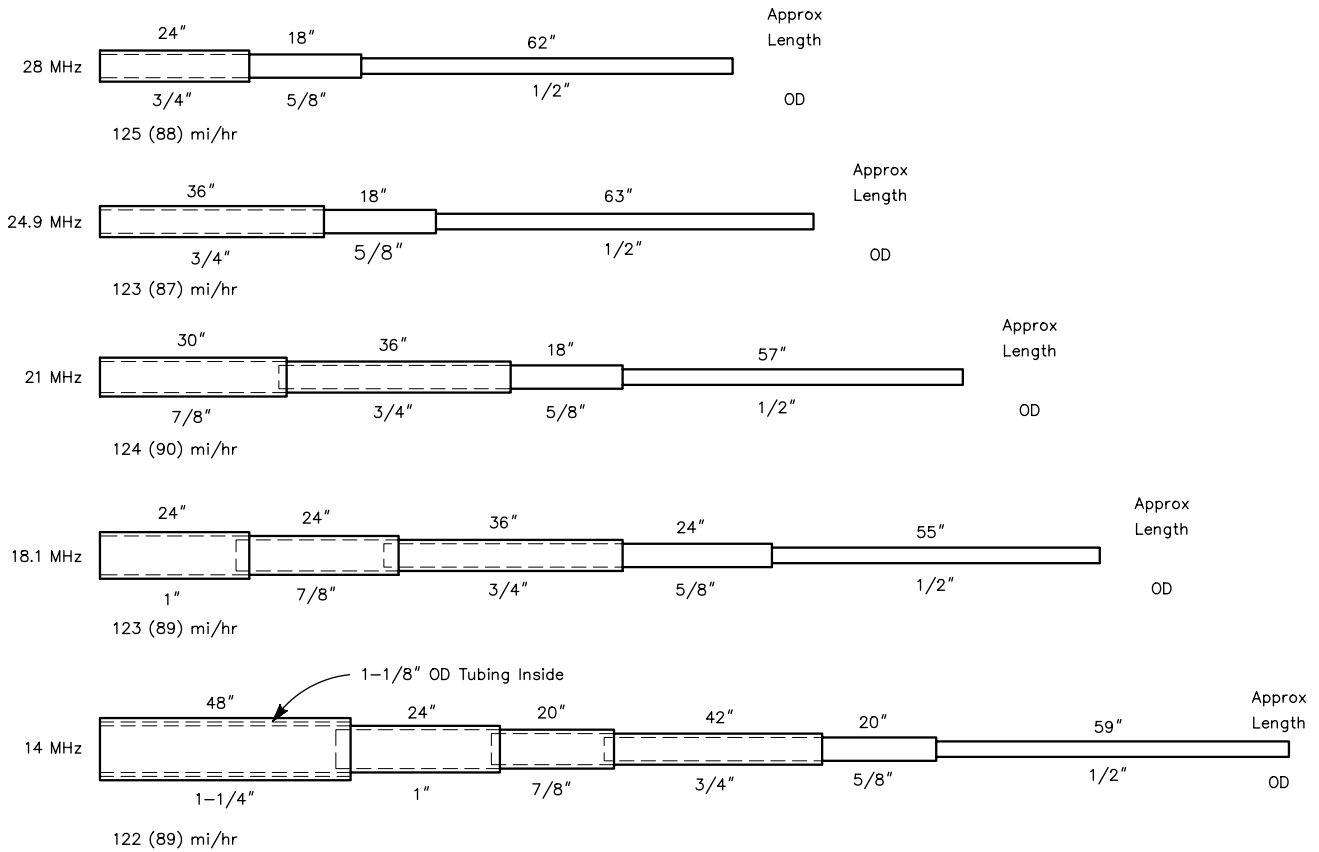
Figs 9 and 10 show only half elements. When the element is assembled, the largest size tubing for each element should be double the length shown in the drawing, with its center being the point of attachment to the boom. These designs are somewhat conservative, in that they are self-resonant slightly below the frequency indicated for each design. Telescoping the outside end sections to shorter lengths for resonance will increase the survival wind speeds. Conversely, lengthening the outside end sections will reduce the survival wind speeds. [See Bibliography listing for [David Leeson \(W6NL, ex-W6QHS\)](#) at the end of this chapter.]

**Fig 11** shows several methods of fastening antenna element sections together. The slot and hose clamp method shown in Fig 11A is probably the best for joints where adjustments are required. Generally, one adjustable joint per element half is sufficient to tune the antenna. Stainless-steel hose clamps (beware—some “stainless steel” models do not have a stainless screw and will rust) are recommended for longest antenna life. **Table 6** shows available hose-clamp sizes.

Figs 11B, 11C and 11D show possible fastening methods for joints that do not require adjustment. At B, machine screws and nuts hold the elements in place. At C, sheet metal screws are used. At D, rivets secure the tubing. If the antenna is to be assembled permanently, rivets are the best choice. Once in place, they are permanent. They will never work free, regardless of vibration or wind. If aluminum rivets with aluminum mandrels are used, they will never rust. In addition, there is no danger of dissimilar-metal corrosion with aluminum rivets and aluminum antenna elements. If the antenna is to be disassembled and moved periodically, either B or C will work. If machine screws are used, however, take all possible precautions to keep the nuts from vibrating free. Use lock washers, lock nuts and flexible sealant such as silicone bathtub sealant to keep the hardware in place.

Very strong elements can be made by using a double thickness of tubing, made by telescoping one size inside another for the total length. This is usually done at the center of an element where more element strength is desired at the boom support point, as in the 14-MHz element in **Fig 10**. Other materials can be used as well, such as wood dowels, fiberglass rods, and so forth.

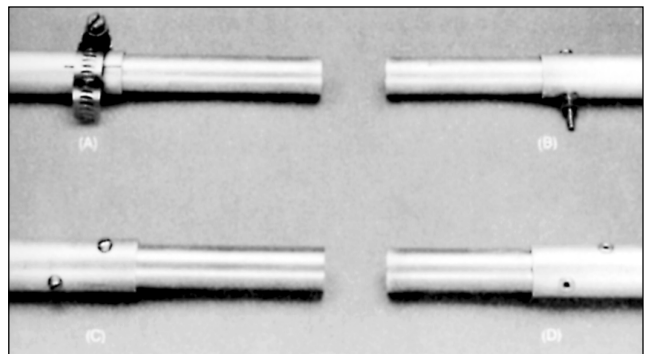
In each case where a smaller diameter length of tubing is telescoped inside a larger diameter one, it's a good idea to coat the inside of the joint with Penetrox or a similar substance to ensure a good electrical bond. Antenna elements have a tendency to vibrate when they are mounted on a tower, and one way to dampen the vibrations is by running a piece of clothesline rope through the length of the element. Cap



**Fig 10—A more rugged schedule of taper proportions for Yagi half-elements than Fig 9. See the Fig 9 caption for details. Table 5 gives details of aluminum tubing sizes.**

**Table 6  
Hose-Clamp Diameters**

Size No.	Clamp Diameter (In.)	
	Min	Max
06	7/16	7/8
08	7/16	1
10	1/2	1 1/8
12	5/8	1 1/4
16	3/4	1 1/2
20	7/8	1 3/4
24	1 1/8	2
28	1 3/8	2 1/4
32	1 5/8	2 1/2
36	1 7/8	2 3/4
40	2 1/8	3
44	2 5/16	3 1/4
48	2 5/8	3 1/2
52	2 7/8	3 3/4
56	3 1/8	4
64	3 1/2	4 1/2
72	4	5
80	4 1/2	5 1/2
88	5 1/8	6
96	5 5/8	6 1/2
104	6 1/8	7



**Fig 11—Methods of connecting telescoping tubing sections to build beam elements. See text for a discussion of each method.**

or tape the end of the element to secure the clothesline. If mechanical requirements dictate (a U-bolt going through the center of the element, for instance), the clothesline may be cut into two pieces.

Antennas for 50 MHz need not have elements larger than 1/2-inch diameter, although up to 1 inch is used occasionally. At 144 and 220 MHz the elements are usually 1/8 to 1/4 inch in diameter. For 420 MHz, elements as small as 1/16 inch diameter work well, if made of stiff rod. Aluminum welding rod of 3/32 to 1/8 inch diameter is fine for 420-MHz arrays, and 1/8 inch or larger is good for the 220-MHz band. Aluminum rod or hard-drawn wire works well at 144 MHz.

Tubing sizes recommended in the paragraph above are

usable with most formula dimensions for VHF/UHF antennas. Larger diameters broaden the frequency response; smaller ones sharpen it. Much smaller diameters than those recommended will require longer elements, especially in 50-MHz arrays.

### Element Taper and Electrical Length

The builder should be aware of one important aspect of telescoping or tapered elements. When the element diameters are tapered, as shown in Figs 9 and 10, the electrical length is not the same as it would be for a cylindrical element of the same total length. Length corrections for tapered elements are discussed in Chapter 2.

## Other Materials for Antenna Construction

Wood is very useful in antenna work. It is available in a great variety of shapes and sizes. Rug poles of wood or bamboo make fine booms. Bamboo is quite satisfactory for spreaders in quad antennas.

Round wood stock (doweling) is found in many hardware stores in sizes suitable for small arrays. Wood is good for the framework of multibay arrays for the higher bands, as it keeps down the amount of metal in the active area of the array. Square or rectangular boom and frame materials can be cut to order in most lumber yards if they are not available from the racks in suitable sizes.

Wood used for antenna construction should be well seasoned and free of knots or damage. Available materials vary, depending on local sources. Your lumber dealer can help you better than anyone else in choosing suitable materials. Joining wood members at right angles can be done with gusset plates, as shown in Fig 12. These can be made of thin outdoor-grade plywood or Masonite. Round materials can be handled in ways similar to those used with metal components, with U clamps and with other hardware.

In the early days of Amateur Radio, hardwood was used as insulating material for antennas, such as at the center and ends of dipoles, or for the center insulator of a driven element made of tubing. Wood dowels cut to length were the most common source. To drive out moisture and prevent the subsequent absorption of moisture into the wood, it was treated before use by boiling it in paraffin. Of course today's technology has produced superior materials for insulators in terms of both strength and insulating qualities. However, the technique is worth consideration in an emergency situation or if low cost is a prime requirement. "Baking" the wood in an oven for a short period at 200° F should drive out any moisture. Then treatment as described in the next paragraph should prevent moisture absorption. The use of wood insulators should be avoided at high-voltage points if high power is being used.

All wood used in outdoor installations should be protected from the weather with varnish or paint. A good

grade of marine spar varnish or polyurethane varnish will offer protection for years in mild climates, and one or more seasons in harsh climates. Epoxy-based paints also offer good protection.

### Plastics

Plastic tubing and rods of various sizes are available from many building-supplies stores. The uses for the available plastic materials are limited only by your imagination. Some amateurs have built beam antennas for VHF using wire elements run inside thin PVC plumbing pipe. The pipe gives the elements a certain amount of physical strength. Other hams have built temporary antennas by wrapping plastic pipe with aluminum foil or other conductive material. Plastic plumbing pipe fittings can also be used to enclose baluns and as the center insulator or end insulators of a dipole, as shown in Fig 13. Plastic or Teflon rod can be used as the core of a loading coil for a mobile antenna

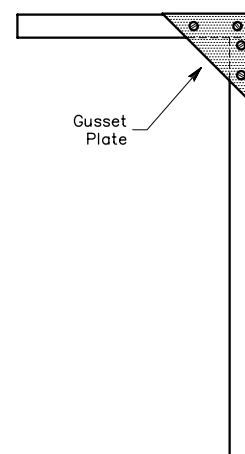
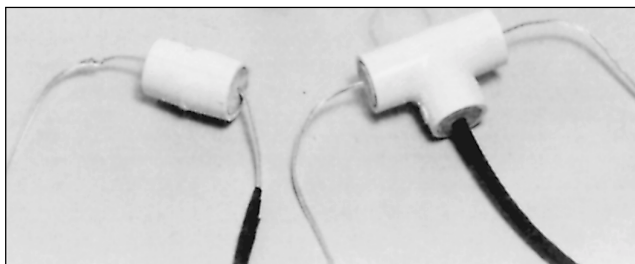


Fig 12—Wood members can be joined at right angles using gusset plates.



**Fig 13—Plastic plumbing parts can be used as antenna center and end insulators.**

(Fig 14) but the material for this use should be selected carefully. Some plastics become quite warm in the presence of a strong RF field, and the loading-coil core might melt or catch fire!

### Fiberglass

Fiberglass poles are the preferred material for spreaders for quad antennas. They are lightweight, they withstand harsh weather well, and their insulating qualities are excellent. One disadvantage of fiberglass poles is that they may be crushed rather easily. Fracturing occurs at the point where the pole is crushed, causing it to lose its strength. A crushed pole is next to worthless. Some amateurs have repaired crushed poles with fiberglass cloth and epoxy, but the original strength is nearly impossible to regain.

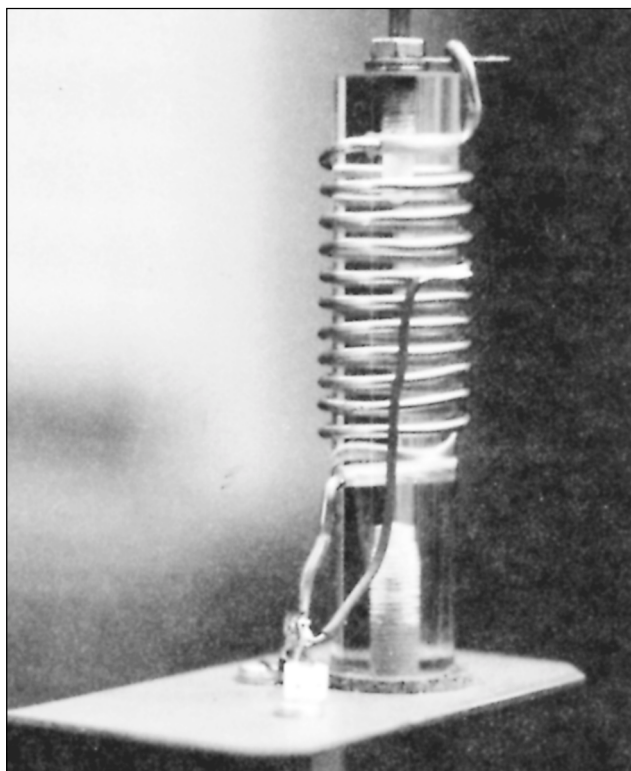
Fiberglass poles can also be used to construct other types of antennas. Examples are helically wound Yagi elements or verticals, where a wire is wound around the pole.

### CONCLUSION

The antenna should be put together with good quality hardware. Stainless steel is best for long life. Rust will quickly attack plated steel hardware, making nuts difficult, if not impossible, to remove. If stainless-steel muffler clamps and hose clamps are not available, the next best thing is to have them plated. If you can't have them plated, at least paint them with a good zinc-chromate primer and a finish coat or two.

Galvanized steel generally has a longer life than plated steel, but this depends on the thickness of the galvanizing coat. Even so, in harsh climates rust will usually develop on galvanized fittings in a few years. For the ultimate in long-term protection, galvanized steel should be further protected with zinc-chromate primer and then paint or enamel before exposing it to the weather.

Good quality hardware is expensive initially, but if you



**Fig 14—A mobile-antenna loading coil wound on a polystyrene rod.**

do it right the first time, you won't have to take the antenna down in a few years and replace the hardware. When the time does come to repair or modify the antenna, nothing is more frustrating than fighting rusty hardware at the top of the tower.

Basically any conductive material can be used as the radiating element of an antenna. Almost any insulating material can be used as an antenna insulator. The materials used for antenna construction are limited mainly by physical considerations (required strength and resistance to outdoor exposure) and by the availability of materials. Don't be afraid to experiment with radiating materials and insulators.

### BIBLIOGRAPHY

Source Material and more extended discussion of topics covered in this chapter can be found in the references given below.

J. J. Elengo, Jr., "Predicting Sag in Long Wire Antennas," *QST*, Jan 1966, pp 57-58.

D. B. Leeson, *Physical Design of Yagi Antennas* (Newington, CT: ARRL).



# Chapter 21

# Antenna Products Suppliers

## Antenna Manufacturers Products

Finding parts can be the most difficult aspect of an antenna project. Suppliers of aluminum exist in most major metropolitan areas. They can be found in the Yellow Pages of the phone book. Some careful searching of the Yellow Pages may also reveal sources of other materials and accessories. If you live away from a metropolitan area, try using telephone books for the nearest large metropolitan area; they may be available in the reference section of your local library.

Many dealers and distributors will ship their products by freight or by mail. The listings of tables 1, 2, 3, 4, 5, 6 and 7 list several categories of antenna products and some suppliers of them. Company names have been abbreviated where necessary. Table 8 is an address list arranged alphabetically by company name.

Product lines change often; we recommend that you request current catalogs from those manufacturers who interest you. In addition, all indications of sales policies and prices for catalogs are given for general information only and are subject to change without notice.

Antenna products for repeaters are listed separately, in Chapter 17.

**Table 1**  
**VHF/UHF/Microwave Antenna Suppliers**

Manufacturer	Yagi	Quad, Loop	Loop Yagi	Vertical	Mobile	HT	μwave	Helical	Satellite
AEA				✓		✓			
Alabama Amateur		✓							
Anli International					✓	✓			
Antennaco	✓								
Antennas West	✓								
Ant Specialists				✓	✓	✓			
Austin Antenna	✓			✓	✓	✓			✓
Butternut				✓					
Cellular Security		✓		✓					
Centurion Tuf Duck						✓			
Comet				✓	✓				
Create Design	✓								
Cubex		✓							✓
Cushcraft	✓			✓	✓	✓			✓
Diamond				✓	✓	✓			
Down East			✓ <sup>1</sup>				✓		✓
Eur-AM	✓				✓				
Hustler	✓			✓	✓	✓			
Kilo-Tec				✓	✓ <sup>2</sup>				
KLM	✓			✓			✓		✓
Lakeview				✓	✓				
Larsen					✓	✓			
M <sup>2</sup>	6m	6m				✓			
Maldol					✓	✓			
Maxrad	✓			✓	✓	✓			
Mosley	✓			✓	✓				
Pro-Am Valor					✓				
Radio Shack				Discone					
Radio Works					✓	✓			
Rutland Arrays	✓								✓
Sommer	✓							✓	✓
Spectrum Int'l	✓		✓ <sup>3</sup>						✓
Telex/Hy-Gain	✓			✓	✓				✓
Texas Radio				✓					
Tonna	✓								

**Notes**

<sup>1</sup>902, 1250, 2400, 3400 MHz    <sup>2</sup>Includes a 144 MHz DRRR.    <sup>3</sup>902, 1250 MHz

**Table 2**  
**HF Antenna Suppliers**

Manufacturer	Yagi	Quad, Loop	Vertical	Dipole	Mobile	Small Xmtng	Active (RX only)
AEA						✓	
Alpha Delta				✓			
Antennas West				✓	✓		
Antennas Etc				✓			
B & W			✓	✓		✓	
Bilal						✓	
Butternut			✓			✓	
Create Design	✓		✓	✓		✓	
Cubex		✓					
Cushcraft	✓		✓				
DC Sales					✓ <sup>1</sup>		
Delta Loop		✓					
Dressler							✓ <sup>2</sup>
Flytecraft			✓		✓		
Force 12	✓						
GAP			✓				
Gem Quad		✓ <sup>3</sup>					
Grove							✓
High Sierra					✓		
Hustler			✓		✓		
Jade Products				✓			
Kilo-Tec				✓		✓	
KLM	✓		✓	✓ <sup>4</sup>			
Lakeview					✓		
Lightning Bolt		✓					
M <sup>2</sup>	✓						
MFJ						✓	✓
Mosley	✓		✓	✓	✓	✓	
N'Tenna		✓					
Nye				✓			
Outbacker					✓		
Palomar							✓
Pro-Am Valor					✓		
Roadrunner					✓		
Sommer	✓						
Spi-Ro				✓			
Telex/Hy-Gain	✓		✓	✓			
Texas Radio				✓	✓		
The Radio Works				✓	✓		
Van Gorden			✓	✓			
W1JC				✓		✓	
W9INN				✓			

**Notes:**

- <sup>1</sup> Trailer-hitch antenna mount
- <sup>2</sup> HF and VHF versions available
- <sup>3</sup> 144-MHz option available
- <sup>4</sup> Rotatable

**Table 3**  
**Antenna Parts**

Manufacturer	Hardware	Insulators	Traps	Aluminum Tubes <sup>1</sup>	Wire
Alexander Aeroplane Co				✓	
Antennas Etc	✓	✓	✓		
Barker & Williamson		✓	✓		
Cable X-Perts	✓	✓	✓		✓
Kilo-Tec	✓	✓			✓
Maxrad	✓				
Metal & Cable, Inc				✓	
Ocean State Electronics	✓	✓			✓
Radiokit		✓			
Spi-Ro		✓	✓		✓
Telex/Hy-Gain		✓			
Texas Radio					
Texas Towers				✓	
The Radio Works		✓			✓
Van Gorden	✓	✓	✓		
The Wireman					✓
W1JC		✓			✓
W9INN					✓

**Notes:**

<sup>1</sup> Also check your local Yellow Pages.

**Table 4**  
**Suppliers of Quad Antenna Parts**

*Fiberglass and Bamboo Poles for Spreaders*

Company	Material Size
Advanced Composites	1 <sup>1</sup> / <sub>4</sub> and 1 <sup>1</sup> / <sub>2</sub> -in. OD, 12 and 20 foot lengths
Cubex Co., Inc.	1 <sup>1</sup> / <sub>4</sub> -1 <sup>1</sup> / <sub>2</sub> in. x 13 ft; 1 <sup>1</sup> / <sub>2</sub> in. x 13 ft cast spiders, boom-to-mast mounts
dB+ Enterprises	1 <sup>1</sup> / <sub>16</sub> -in. diameter, 13-ft lengths. Severe-duty cubical quads and accessories.
Lightning Bolt	Custom made fiberglass spreaders, any length
Sky-Pole Manufacturing, Inc.	Vauling poles and tubing of various sizes and lengths. 1 to 1 <sup>5</sup> / <sub>8</sub> -in. tubing in odd lengths.
Tropical Accents	Bamboo poles

**Table 5**  
**Towers, Masts and Accessories**

*Towers*

Aluma  
Create Design  
Glen Martin Engineering  
Heights Tower  
National Tower  
Radio Shack (masts only)  
Rohn  
Telex/Hy-Gain  
Texas Tower  
Tri-Ex  
Trylon  
Universal Manufacturing  
US Tower

*Climbing and Safety Equipment*

ONV  
RADIOKIT

*Rotators*

C.A.T.S. (repair)  
Create Design  
Mosley  
Ocean State Electronics  
Radio Shack  
Telex/Hy-Gain  
Yaesu

*Stacking Frames*

(Unless otherwise noted these frames are for use in stacking the manufacturer's own antennas in pairs or quads. These stacking kits are for VHF or UHF antennas only.)

Cushcraft  
Down East  
IIX  
Mosley  
Rutland Arrays  
Spectrum International

*Combiners, Power Dividers and Phasing Harnesses*

(These devices are usually made by a manufacturer for use when stacking his antennas in pairs or quads)

Byers (Not specific to particular antennas, kits only for 144-1250 MHz)  
Cushcraft  
Down East  
Spectrum International  
Tonna

**Table 6**  
**Transmission Lines**

Major manufacturers of cable usually do not sell direct to amateurs. Almost all ham distributors sell coax cables. The companies listed below specialize in selling RF connectors and transmission lines.

Source	Coax	Hardline	Ladder Line
AGW		✓	
Belden	✓	✓	
Cable X-Perts	✓	✓	✓
International Wire & Cable	✓		
Nemal	✓	✓	
RADKIOKIT			✓
The Radio Works	✓		✓
W1JC			✓
W9INN			✓
The Wireman	✓	✓	✓

**Table 7**  
**Transmission Line Instruments and Accessories**

**Matching Networks**

Ameritron  
Barker & Williamson  
Cubex  
ICOM (mobile & fixed)  
Kenwood  
MFJ  
Nye  
Ocean State Electronics  
Ten-Tec  
Texas Radio (mobile only)  
Vectronics

**Ferrite Cores and Rods**

Amidon  
Palomar  
RADIOKIT

**Filters—TVI (Low Pass and High Pass)**

Antennas Etc  
K-Com  
Tucker Electronics

**Lightning Arresters**

Alpha Delta  
Ameritron  
Comet  
Cushcraft  
Industrial Communication Engineers  
Lightning and Noise Protectors  
MFJ  
Polyphaser  
Radioware  
Rohn  
Telex/Hy-Gain  
The Wireman  
Zero Surge Inc

**Switches (Manual, Coax)**

Alpha Delta  
Barker & Williamson  
MFJ

**Switches (Remote, Coax)**

Ameritron  
Antennas Etc

**SWR and Wattmeters**

AEA (SWR analyzer)  
Autek  
Bird  
Coaxial Dynamics  
Dielectric Communications  
MFJ (SWR analyzer)  
Nye (including audible version for the visually impaired)  
Palomar  
RF Parts  
Texas Radio

**Table 8**  
**Suppliers Addresses**

We have made every effort to ensure that this list is complete and accurate as of early 2000. The ARRL takes no responsibility for errors or omissions. Similarly, a listing here does not represent an endorsement of a manufacturer or products by the ARRL. Refer to the product reviews in *QST* for descriptions of particular products that interest you. To the best of our knowledge the suppliers listed are willing to sell products to amateurs by mail unless indicated otherwise. This listing will be updated with each edition of *The Antenna Book* and *The ARRL Handbook* in the TISFIND manufacturer database. Check ads in *QST* and other Amateur Radio publications for any changes to this information. Suppliers who wish to be listed or update their information are urged to contact the editors.

**Key to symbols used:**  
N = No direct sales, sells through distributors only  
D = Direct sales only  
K = Product available in kit form only (most beam antennas require some assembly but are not listed as kits)  
U = Sells used parts/equipment

Advanced Composites  
1154 S. 300 W.  
Salt Lake City, UT 84101  
801-467-1204  
fax: 801-467-4367  
email: [info@advancedcomposites.com](mailto:info@advancedcomposites.com)

AEA—Div. Tempo Research Corporation  
1221 Liberty Way  
Vista, CA 92083  
760-598-9677  
fax: 760-598-4898  
e-mail: [temp@inetworld.com](mailto:temp@inetworld.com)  
<http://www.aea-wireless.com>

AGW Enterprises, Inc (D)  
RD #10, Rte 206  
Vincentown, NJ 08088

Alexander Aeroplane Co  
PO Box 909  
Griffin, GA 30224  
800-831-2949  
404-229-2329

Alpha Delta  
Communications  
PO Box 620  
Manchester, KY 40962  
606-598-2029  
fax: 606-598-4413

Aluma Tower Co, Inc  
PO Box 2806-AL  
Vero Beach, FL 32961-2806  
561-567-3423  
fax: 561-567-3432  
e-mail: [atc-t@alumatower.com](mailto:atc-t@alumatower.com)  
<http://www.alumatower.com/index.html>

Amateur Electronic Supply  
5710 W Good Hope Rd  
Milwaukee, WI 53223  
800-558-0411  
<http://www.aesham.com/>

Ameritron Division  
921 Louisville Rd  
Starkville, MS 39759  
601-323-9715  
601-323-6551  
e-mail: [76206.1763@compuserve.com](mailto:76206.1763@compuserve.com)  
<http://www.ameritron.com>

Amidon Inc.  
240 & 250 Briggs Ave  
Costa Mesa, CA 92626  
714-850-4660  
fax: 714-850-1163  
email: [sales@amidoncorp.com](mailto:sales@amidoncorp.com)  
<http://www.amidoncorp.com>

Antennaco Inc (K)  
102 Armory Road  
PO Box 218  
Milford, NH 03055-0218  
603-673-3153  
fax: 603-673-4347

Antenna Specialists Co (N)  
Div of Allen TeleCom Group  
30500 Bruce Industrial Pkwy  
Cleveland, OH 44139-3996  
216-349-8400  
fax: 216-349-8407  
<http://www.antenna.com/>

ASA Antenna Sales  
PO Box 3461  
Myrtle Beach, SC 29578  
800-772-2681

Associated Radio Communications  
8012 Conser  
Overland Park, KS 66204  
913-381-5900  
800-497-1457  
fax: 913-648-3020  
e-mail: [assocrad@tfs.net](mailto:assocrad@tfs.net)  
<http://www.associatedradio.com>

Austin Amateur Radio Supply  
5310 Cammeron Road  
Austin, TX 78723  
800-423-2604  
512-454-2994  
fax: 512-454-3069

Austin Antenna, Ltd  
10 Main St  
Gonic, NH 03839  
603-336-6339  
fax: 603-335-1756

Autek Research  
PO Box 8772  
Madeira Beach, FL 33738  
813-886-9515

Barker & Williamson Co  
603 Cidco Rd  
Cocoa, FL 32926  
321-639-1510  
fax: 321-639-2545  
email: [custsrc@bwantennas.com](mailto:custsrc@bwantennas.com)  
<http://www.bwantennas.com>

Barry Electronics Corp  
540 Broadway  
New York, NY 10012  
212-925-7000  
fax: 212-925-7001

Belden Wire & Cable  
PO Box 1980  
Richmond, IN 47374  
317-983-5257  
fax: 317-983-5257  
<http://www.belden.com>

Bird Electronic Corp (N)  
30303 Aurora Rd  
Cleveland, OH 44139  
440-248-1200  
fax: 440-248-5426  
<http://www.bird-electronic.com>

Brian Beezley, K6STI  
3532 Linda Vista Dr  
San Marcos, CA 92069  
619-599-4962  
e-mail: [k6sti@n2.net](mailto:k6sti@n2.net)

Burghardt Amateur Center, Inc  
710 10th St  
PO Box 73  
Watertown, SD 57201  
800-927-4261  
605-886-7314 (Service)  
fax: 605-886-3444  
email: [burghardt@daknet.com](mailto:burghardt@daknet.com)  
<http://www.burghardt-amateur.com>

Butternut Electronics Co (N)  
831 North Central Ave  
Wood Dale, IL 60191  
708-238-1854  
fax: 708-238-1186

Byers Chassis Kit (D,K)  
5120 Harmony Grove Rd  
Dover, PA 17315  
717-292-4901

Cable X-Perts Inc  
416 Diens Drive  
Wheeling, IL 60090  
847-520-3003  
fax: 847-520-3444  
e-mail: [cxp@ix.netcom.com](mailto:cxp@ix.netcom.com)  
<http://www.cablexperts.com>

Cardwell Condenser Corp  
80 East Montauk Hwy  
Lindenhurst, Long Island, NY 11757  
516-957-7200  
fax: 516-957-7203  
<http://www.cardwellcondenser.com>

C.A.T.S. (D,U)  
Now known as: The Rotor Doctor  
7368 SR 105  
Pemberville, OH 43450  
419-352-4465  
fax: 419-353-2287  
<http://www.rotordoc.com>

C-Comm  
6115 15th NW  
Seattle, WA 98107  
206-784-7337  
800-426-6528  
fax: 206-784-0541

Centurion International  
PO Box 82846  
Lincoln, NE 68501-2846  
402-467-4491  
fax: 800-848-3825

Coaxial Dynamics Inc  
15210 Industrial Pkwy  
Cleveland, OH 44135  
216-267-2233  
fax: 216-267-3142  
email: [coaxial@apk.net](mailto:coaxial@apk.net)  
<http://www.coaxial.com>

Comet  
sold by **NCG**

Comm-Pute, Inc  
7946 State Street  
Midvale, UT 84047  
800-942-8873  
801-567-9494  
e-mail: [bob@comm-pute.com](mailto:bob@comm-pute.com)

Communication Headquarters Inc  
3832 Oleander Dr  
Wilmington, NC 28403  
910-791-8885  
fax: 910-452-3891  
<http://www.chq-inc.com/>

Communications Data Corp  
1051 Main St  
St Joseph, MI 49085  
616-982-0404  
fax: 619-982-0433  
e-mail: [did@qtm.net](mailto:did@qtm.net)

Comtelco Industries Inc  
501 Mitchell Rd  
Glendale Heights, IL 60139  
800-634-4622  
708-7790-9894  
fax: 708-798-9799

Create Design or Creative Design  
sold by EDCO

Cubex Co, Inc  
228 Hibiscus St, Unit 9  
Jupiter, FL 33458  
561-748-2830  
fax: 561-748-2831  
e-mail: [cubexco@aol.com](mailto:cubexco@aol.com)  
<http://www.cubex.com/>

Cushcraft Corp  
PO Box 4680  
Manchester, NH 03108  
603-627-7877  
fax: 603-627-1764  
e-mail: [hamsales@cushcraft.com](mailto:hamsales@cushcraft.com)  
<http://www.cushcraft.com>

Davis RF Co  
PO Box 730  
Carlisle, MA 01741  
800-328-4773 (orders and general info)  
978-369-1738 (technical info)  
e-mail: [davisrfinc@aol.com](mailto:davisrfinc@aol.com)  
<http://www.davisrf.com>

Diamond Antennas  
see **RF Parts**

Down East Microwave  
954 Rt 519  
Frenchtown, NJ 08825  
908-996-3584  
fax: 908-996-3702  
<http://downeastmicrowave.com/>

Dressler Hochfrequenztechnik GMBH  
Werther Strasse 14-16  
W-5190 Stolberg  
Germany

EDCO Electronics Distributors (Create  
Design)  
325 Mill St  
Vienna, VA 22180  
703-938-8105  
fax: 703-939-6911  
<http://www.elecdist.com>

Eur-AM  
PO Box 990  
Meredith, NH 03253-0990  
603-279-1393  
fax: 603-279-1394

Flytecraft  
PO Box 3141  
Simi Valley, CA 93093  
805-583-8173

Force 12 Antennas and Systems  
PO Box 1349  
Paso Robles, CA 93447  
800-248-1985 (orders)  
805-227-1680  
fax: 805-227-1684  
e-mail: [force12@qth.com](mailto:force12@qth.com)  
<http://www.qth.com/force12>

GAP Antenna Products  
99 North Willow St  
Fellsmere, FL 32948  
561-571-9922  
fax: 561-571-9988

Gem Quad Products Ltd (D)  
PO Box 291  
Boissevain, MB R0K 0E0  
Canada  
204-534-6184  
fax: 204-534-6492  
e-mail: [gemquad@escape.ca](mailto:gemquad@escape.ca)  
<http://www.escape.ca/~gemquad/>

GLA Systems  
e-mail: [info@texasbugcatcher.com](mailto:info@texasbugcatcher.com)  
<http://texasbugcatcher.com/>

Grove Enterprises  
PO Box 98  
Brasstown, NC 28902  
704-837-9200 (BBS)  
704-837-2216  
e-mail: [nada@grove.net](mailto:nada@grove.net)  
<http://www.grove-ent.com>

Ham Radio Outlet  
1702 W. Camelback Rd  
Phoenix, AZ 85015  
<http://www.hamradio.com/>  
800-444-4799 Mid Atlantic  
800-444-9476 Mountain  
800-444-0047 New England  
800-644-4476 Northeast  
800-444-7927 Southeast  
800-854-6046 West

Ham Station  
220 N Fulton Ave  
PO Box 6522  
Evansville, IN 47719-0522  
812-422-0231  
fax: 812-422-4253  
e-mail: [sales@hamstation.com](mailto:sales@hamstation.com)  
<http://www.hamstation.com>

Hamtronics, Inc (D)  
65-Q Moul Rd  
Hilton, NY 14468  
716-392-9430  
fax: 716-392-9420  
<http://www.hamtronics.com>

High Sierra Antennas  
PO Box 2389  
Nevada City, CA 95959  
916-273-3415  
fax: 916-273-7561  
e-mail: [heath@hsantennas.com](mailto:heath@hsantennas.com)  
<http://www.hsantennas.com/info/>

Hustler/Newtronics Antenna Corp (N)  
1 Newtronics Place  
Mineral Wells, TX 76067  
817-325-1386  
fax: 817-328-1409

Hy-Gain  
see **MFJ**

Industrial Communications Engineers  
(ICE)  
PO Box 18495  
Indianapolis, IN 46218-0495  
317-545-5412  
800-423-2666  
fax: 317-545-9645  
<http://www.inducomm.net>

IIX Equipment Ltd  
PO Box 9  
Oak Lawn, IL 60454  
708-423-0605  
fax: 708-423-1691  
<http://www5.interaccess.com/iixeqpt/>

International Radio  
13620 Tyee Road  
Umpqua, OR 97486  
541-459-5623  
fax: 541-459-5632  
e-mail: [inrad@rosenet.net](mailto:inrad@rosenet.net)  
web: [www.qth.com/inrad/](http://www.qth.com/inrad/)

Jade Products  
PO Box 368  
East Hampstead, NH 03826-0368  
800-523-3776  
603-329-6995  
fax: 603-329-4499  
e-mail: [jadepro@jadeprod.com](mailto:jadepro@jadeprod.com)  
<http://www.jadeprod.com>

Kilo-Tec (D)  
PO Box 10  
Oakview, CA 93022  
805-646-9645

K-COM  
PO Box 82  
Randolph, OH 44265  
330-325-2110  
fax: 330-325-2525  
e-mail: [k-com@worldnet.att.net](mailto:k-com@worldnet.att.net)  
<http://www.k-comfilters.com/>

Lakeview Co Inc  
3620-9A Whitehall Rd  
Anderson, SC 29626  
864-226-6990  
fax: 864-225-4565  
<http://www.hamstick.com>

Larsen Electronics, Inc (N)  
PO Box 1799  
Vancouver, WA 98668-1799  
800-426-1656  
360-944-7551  
<http://www.larsenet.com>

Lentini Communications  
21 Garfield St  
Newington, CT 06111  
860-666-6227  
fax: 860-667-3561  
e-mail: [radio@lentinicomm.com](mailto:radio@lentinicomm.com)  
<http://www.lentinicomm.com>

Lawallen, Roy W7EL  
PO Box 6658  
Beaverton, OR 97007  
503-646-2885  
fax: 503-671-9046  
e-mail: [w7el@teleport.com](mailto:w7el@teleport.com)

Lightning Bolt Antennas (D)  
RD #2, Rte 19  
Volant, PA 16156  
724-530-7396  
fax: 724-530-6796  
<http://lbq.isrv.com/>

M<sup>2</sup> Enterprises (D)  
7560 N Del Mar Ave  
Fresno, CA 93711  
559-432-8873  
fax: 559-432-3059  
<http://www.m2inc.com>

M/A-COM, Inc (an AMP Company)  
1011 Pawtucket Blvd  
PO Box 3295  
Lowell, MA 01853-3295  
508-442-4500  
fax: 508-442-4436  
e-mail: [sales@macom.com](mailto:sales@macom.com)  
<http://www.amp.com>

Maldol USA  
4711 NE 50th St  
Seattle, WA 98105  
Answerfax: 206-525-1896  
fax: 206-524-7826  
email: [transtec@cyberquest.com](mailto:transtec@cyberquest.com)

Glen Martin Engineering  
RR 3, Box 322  
Boonville, MO 65233  
816-882-2734  
fax: 816-882-7200  
<http://www.glenmartin.com>

MCM Electronics  
650 Congress Park Dr  
Centerville, OH 45459-4072  
800-543-4330  
fax: 800-765-6960  
<http://www.i-mcm.com/>

Memphis Amateur Electronics  
1465 Wells Station Rd  
Memphis, TN 38108  
901-683-9125  
800-238-6168  
fax: 901-682-7165

Metal & Cable Corp, Inc (D)  
9241 Ravenna Road, Unit C-10  
PO Box 117  
Twinsburg, OH 44087  
216-425-8455  
fax: 216-425-3504  
<http://www.metal-cable.com>

MFJ Enterprises, Inc  
PO Box 494  
Mississippi State, MS 39762  
800-647-1800  
fax: 662-323-6551  
e-mail: [techinfo@mfjenterprises.com](mailto:techinfo@mfjenterprises.com)  
<http://www.mfjenterprises.com>

Michigan Radio  
23040 Schoenherr  
Warren, MI 48089  
810-771-4711  
fax: 810-771-6546

Mirage Communications  
300 Industrial Park Rd  
Starkville, MS 39759  
662-323-8287  
fax: 662-323-6551  
<http://www.mirageamp.com>

James Millen Electronics Mfg  
PO Box 4215BV  
Andover, MA 01810-4215  
508-975-2711  
fax: 508-474-8949  
e-mail: [info@jamesmillen.com](mailto:info@jamesmillen.com)  
<http://www.jamesmillenco.com/>

Mosley Electronics, Inc  
1325 Style Master Dr  
Union, MO 63084  
800-966-7539  
636-583-8595 (Technical)  
fax: 636-583-0890  
<http://www.mosley-electronics.com>

Multi-Band Antennas (Spider Antennas)  
7131 Owensworth Ave,  
Suite 63C  
Canoga Park, CA 91303  
818-341-5460  
<http://www.spiderantenna.com>

National Tower Co  
PO Box 15417  
Shawnee Mission, KS 66285  
800-762-5049  
913-888-8864

NCG Companies—Comet Antenna  
1275 North Grove St  
Anaheim, CA 92806  
714-630-4541  
800-962-2611  
fax: 714-630-7024  
<http://www.cometantenna.com>

Nemal Electronics International, Inc (D)  
12240 NE 14th Ave  
North Miami, FL 33161  
305-893-3924  
800-522-2253  
fax: 305-895-8178  
e-mail: [nemal@mcimail.com](mailto:nemal@mcimail.com)  
<http://www.nemal.com>

William M. Nye Co  
PO Box 1877  
Priest River, ID 83856  
208-448-1762  
fax: 208-448-1832

Ocean State Electronics  
PO Box 1458  
6 Industrial Dr  
Westerly, RI 02891  
401-596-3080  
800-866-6626  
fax: 401-596-3590  
<http://www.oselectronics.com>

ONV Safety Belt  
PO Box 404  
Ramsey, NJ 07446  
800-345-5634  
fax: 201-327-2462

Orion  
now sold by M<sup>2</sup>

Outbacker Antenna Sales  
330 Cedar Glen Circle  
Chattanooga, TN 37412  
615-899-3390  
fax: 615-899-6536

Palomar Engineers  
PO Box 462222  
Escondido, CA 92046  
760-747-3343  
fax: 760-747-3346  
e-mail: [75353.2175@compuserve.com](mailto:75353.2175@compuserve.com)  
<http://www.palomar-engineers.com/>

Phillystran, Inc  
151 Commerce Dr  
Montgomeryville, PA 18936  
215-368-6611  
fax: 215-362-7956  
<http://www.phillystran.com/Default.htm>

PolyPhaser Corp  
2225 Park Place  
PO Box 9000  
Minden, NV 89423-9000  
702-782-2511  
fax: 702-782-4476  
e-mail: [info@polyphaser.com](mailto:info@polyphaser.com)  
<http://www.polyphaser.com>

Radio Bookstore/Radioware  
PO Box 209  
Rindge, NH 03461  
800-457-7373  
fax: 603-899-6826  
e-mail: [nx1g@top.monad.net](mailto:nx1g@top.monad.net)  
<http://www.radiobooks.com>

Radio Center USA  
1242 Howell  
N. Kansas City, MO 64116  
816-459-8832  
800-821-7323

Radio City  
2663 County Rd I  
Mounds View, MN 55112  
612-786-4475  
800-426-2891  
fax: 612-786-6513  
<http://www.radioinc.com>

Radio Engineers  
7969 Engineer Road, Suite 102  
San Diego, CA 92111  
619-565-1319  
fax: 619-571-5909

Radio Shack  
(Contact your local store)

Radio Switch Corp  
64 South Main St,  
PO Box 159  
Marlboro, NJ 07746-0159  
908-462-6100

Radio Works (D)  
PO Box 6159  
Portsmouth, VA 23703  
804-484-0140  
fax: 804-483-1873  
800-280-8327  
e-mail: [jim@radioworks.com](mailto:jim@radioworks.com)  
<http://www.radioworks.com>

RF Parts Co  
435 South Pacific St  
San Marcos, CA 92069  
619-744-0700  
fax: 619-744-1943  
e-mail: [rf@rfparts.com](mailto:rf@rfparts.com)  
<http://www.rfparts.com>

Roadrunner Resonator  
1850 Swanson, #A20  
Lake Havasu, AZ 86403  
520-453-7211

Rohn  
6718 West Plank Rd  
Peoria, IL 61604  
309-697-4400  
fax: 309-697-5612  
e-mail: [mail@rohnet.com](mailto:mail@rohnet.com)  
<http://www.rohnet.com/>

Ross Distributing Co  
78 South State St  
Preston, ID 83263  
208-852-0830  
fax: 208-852-0833  
<http://www.rossdist.com>

The Rotor Doctor (formerly C.A.T.S.)  
7368 SR 105  
Pemberville, OH 43450  
419-352-4465  
fax: 419-353-2287  
<http://www.rotordoc.com>

Shoestring Antennas  
PO Box 425  
Keyport, WA 98345  
360-697-8416  
e-mail: [jacksa@juno.com](mailto:jacksa@juno.com)  
<http://www.qth.com/shoestring>

Sky-Pole Manufacturing, Inc  
1922 Placentia Ave  
Costa Mesa, CA 92627

Sommer Antennas (D)  
PO Box 710  
Geneva, FL 32732  
407-349-9114  
fax: 407-349-2485  
e-mail: [sommer1@ix.netcom.com](mailto:sommer1@ix.netcom.com)  
<http://www.sommerantennas.com>

Spectrum International, Inc (D)  
PO Box 1084  
Concord, MA 01742  
508-263-2145  
fax: 508-263-7008

Spi-Ro Manufacturing, Inc  
PO Box 2800  
Hendersonville, NC 28793  
704-693-1001

Surplus Sales of Nebraska (U)  
1502 Jones St  
Omaha, NE 68102-3112  
402-346-4750  
fax: 402-346-2939  
e-mail: [grinnell@surplussales.com](mailto:grinnell@surplussales.com)  
<http://www.surplussales.com>

Telex Communications, Inc (N)  
Hy-Gain (see MFJ)  
8601 East Cornhusker Hwy  
Lincoln, NE 68505  
402-467-5321  
402-465-7021 (parts and service)  
fax: 402-467-3279

Tennadyne  
HC81, Box 347A  
Junction, TX 76849  
915-446-4510  
<http://www.tennadyne.com>

Texas Radio Products  
5 E Upshaw  
Temple, TX 76501  
817-771-1188

Texas Towers  
1108 Summit Ave, Suite 4  
Plano, TX 75074  
800-272-3467  
972-422-7306  
e-mail: [sales@texastowers.com](mailto:sales@texastowers.com)  
<http://www.texastowers.com>

TIC General  
PO Box 1 - 1110 Airport Rd  
Thief River Falls, MN 56701  
218-681-1119  
fax: 218-681-8509

Tri-Ex Tower  
7182 Rasmussen Ave  
Visalia, CA 93291  
800-328-2393 (orders)  
209-651-7850 ext 352 or 353  
fax: 209-651-5157

Tucker Electronics and Computers  
1717 Reserve St.  
PO Box 551419  
Garland, TX 75355-1419  
800-527-4642 (Test equip-  
ment and catalog requests)  
800-559-7388 (Radio orders)  
fax: 214-340-5460  
web: <http://www.tucker.com/>

Unadilla Antenna  
PO Box 4215  
Andover, MA 01810-4215  
508-975-2711  
fax: 508-474-8949  
<http://www.unadilla.com/unadilla>

Universal Manufacturing Co  
43900 Groesbeck Hwy  
Clinton Township, MI 48036  
810-463-2560  
fax: 810-463-2964

US Tower Corp  
1220 Marcin St  
Visalia, CA 93291  
209-733-2438  
<http://www.ustower.com>

Valor Enterprises  
1711 Commerce Dr  
PO Box 601  
Piqua, OH 45346-0601  
513-778-0074  
800-543-2197  
fax: 513-778-8259

Van Gorden Engineering  
PO Box 21305  
South Euclid, OH 44121

Van Valzah Co  
38 W 111 Horseshoe Dr  
Batavia, IL 60515-9730  
708-406-9210

Vectronics  
1007 Highway 25 South  
Starkville, MS 39759  
800-363-2922  
662-323-5800  
fax: 662-323-6551  
e-mail: [jshurden@vectronics.com](mailto:jshurden@vectronics.com)  
<http://www.vectronics.com>

W1JC—TV Evans  
113 Stratton Brook Rd  
Simsbury, CT 06070  
860-658-5579  
<http://pages.prodigy.com/w1jc>

W9INN Antennas (D)  
PO Box 393  
Mt Prospect, IL 60056  
847-394-3414

Wacom Products  
PO Box 21145  
Waco, TX 76702  
817-848-4435  
fax: 817-848-4209  
<http://hpf.dbcity.com/QISV/Wacom/wacom.html>

The Wireman Inc  
261 Pittman Rd  
Landrum, SC 29356-9544  
864-895-4195 (technical)  
800-727-9473 (orders only)  
fax: 803-895-5811  
e-mail: [info@thewireman.com](mailto:info@thewireman.com)  
<http://www.thewireman.com>

Yaesu USA (N)  
17210 Edwards Rd  
Cerritos, CA 90703  
562-404-2700  
fax: 562-404-1210  
<http://www.yaesu.com/>

YagiStress  
1581 Shirley St  
Minden, NV 89423-9044  
e-mail: [K7NV@contesting.com](mailto:K7NV@contesting.com)  
<http://yagistress.freeyellow.com/>

# Antenna Supports

A prime consideration in the selection of a support for an antenna is that of structural safety. Building regulations in many localities require that a permit be obtained in advance of the erection of certain structures, often including antenna poles or towers. In general, localities having such requirements also have building safety codes that must be observed. Such regulations may govern the method and materials used in construction of, for example, a self-supporting tower. Checking with your local government building department before putting up a tower may save a good deal of difficulty later, because a tower would have to be taken down or modified if not approved by the building inspector on safety grounds.

Municipalities have the right and duty to enforce any reasonable regulations having to do with the safety of life or property. The courts generally have recognized, however, that municipal authority does not extend to esthetic questions. The fact that someone may object to the mere presence of a pole, tower or other antenna structure because in his opinion it detracts from the beauty of the neighborhood is not grounds for refusing to issue a permit for a safe structure to be erected. Since the introduction of PRB-1 (federal preemption of unnecessarily restrictive antenna ordinances), this principle has been borne out in many courts. Permission for erecting amateur towers is more easily obtained than in the recent past because of this legislation.

Even where local regulations do not exist or are not enforced, the amateur should be careful to select a location and a type of support that contribute as much safety as possible to the installation. If collapse occurs, the chances of personal injury or property damage should be minimized by careful choice of design and erection methods. A single injury can be far more costly than the price of a more rugged support, in terms of both monetary loss and damage to the public respect for amateur radio.

This chapter has been reviewed and rewritten by Kurt Andress, K7NV.

## TREES AS ANTENNA SUPPORTS

From the beginning of Amateur Radio, trees have been used widely for supporting wire antennas. Trees cost nothing to use, and often provide a means of supporting a wire

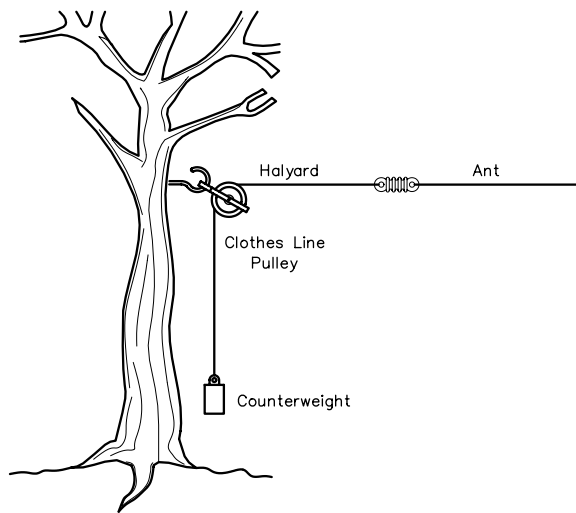
antenna at considerable height. As antenna supports, trees are unstable in the presence of wind, except in the case of very large trees used to support antennas well down from the top branches. As a result, tree-supported antennas must be constructed much more sturdily than is necessary with stable supports. Even with rugged construction, it is unlikely that an antenna suspended from a tree, or between trees, will stand up indefinitely. Occasional repair or replacement usually must be expected.

There are two general methods of securing a pulley to a tree. If the tree can be climbed safely to the desired level, a pulley can be attached to the trunk of the tree, as shown in [Fig 1](#). To clear the branches of the tree, the antenna end of the halyard can be tied temporarily to the tree at the pulley level. Then the remainder of the halyard is coiled up, and the coil thrown out horizontally from this level, in the direction in which the antenna runs. It may help to have the antenna end of the halyard weighted.

After attaching the antenna to the halyard, the other end is untied from the tree, passed through the pulley, and brought to ground along the tree trunk in as straight a line as possible. The halyard need only be long enough to reach the ground after the antenna has been hauled up. (Additional rope can be tied to the halyard when it becomes necessary to lower the antenna.)

The other method consists of passing a line over the tree from ground level, and using this line to haul a pulley up into the tree and hold it there. Several ingenious methods have been used to accomplish this. The simplest method employs a weighted pilot line, such as fishing line or mason's chalk line. By grasping the line about two feet from the weight, the weight is swung back and forth, pendulum style, and then heaved with an underhand motion in the direction of the treetop.

Several trials may be necessary to determine the optimum size of the weight for the line selected, the distance between the weight and the hand before throwing, and the point in the arc of the swing where the line released. The weight, however, must be sufficiently large to carry the pilot line back to ground after passing over the tree. Flipping the end of the line up and down so as to put a traveling wave on the line often helps to induce the weight to drop down if the



**Fig 1—A method of counterweighting to minimize antenna movement and avoid its breaking from tree movement in the wind. The antenna may be lowered without climbing the tree by removing the counterweight and tying additional rope at the bottom end of the halyard. Excess rope may be left at the counterweight for this purpose, as the knot at the lower end of the halyard will not pass through the pulley.**

weight is marginal. The higher the tree, the lighter the weight and the pilot line must be. A glove should be worn on the throwing hand, because a line running swiftly through the bare hand can cause a severe burn.

If there is a clear line of sight between ground and a particularly desirable crotch in the tree, it may eventually be possible to hit the crotch after a sufficient number of tries. Otherwise, it is best to try to heave the pilot line completely over the tree, as close to the centerline of the tree as possible. If it is necessary to retrieve the line and start over again, the line should be drawn back very slowly; otherwise the swinging weight may wrap the line around a small limb, making retrieval impossible.

Stretching the line out straight on the ground before throwing may help to keep the line from snarling, but it places extra drag on the line, and the line may snag on obstructions overhanging the line when it is thrown. Another method is to make a stationary reel by driving eight nails, arranged in a circle, through a 1-inch board. After winding the line around the circle formed by the nails, the line should reel off readily when the weighted end of the line is thrown. The board should be tilted at approximately right angles to the path of the throw.

Other devices that have been used successfully to pass a pilot line over a tree are a bow and arrow with heavy thread tied to the arrow, and a short casting rod and spinning reel used by fishermen. The Wrist Rocket slingshot made from surgical rubber tubing and a metal frame has proved highly effective as an antenna-launching device. Still another

method that has been used where sufficient space is available is flying a kite to sufficient altitude, walking around the tree until the kite string lines up with the center of the tree, and paying out string until the kite falls to the earth. This method can be used to pass a line over a patch of woods between two higher supports, which may be impossible using any other method.

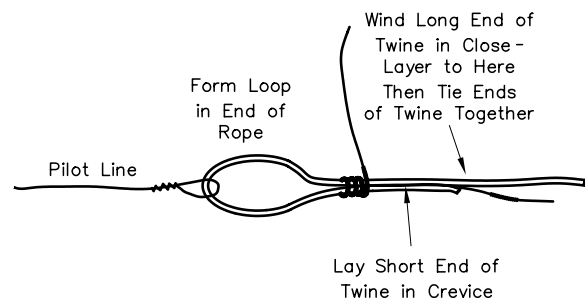
The pilot line can be used to pull successively heavier lines over the tree until one of adequate size to take the strain of the antenna has been reached. This line is then used to haul a pulley up into the tree after the antenna halyard has been threaded through the pulley. The line that holds the pulley must be capable of withstanding considerable chafing where it passes through the crotch, and at points where lower branches may rub against the standing part. For this reason, it may be advisable to use galvanized sash cord or stranded guy wire for raising the pulley.

Larger lines or cables require special attention when they must be spliced to smaller lines. A splice that minimizes the chances of coming undone when coaxed through the tree crotch must be used. One type of splice is shown in **Fig 2**.

The crotch in which the line first comes to rest may not be sufficiently strong to stand up under the tension of the antenna. If, however, the line has been passed over (or close to) the center line of the tree, it will usually break through the lighter crotches and come to rest in a stronger one lower in the tree.

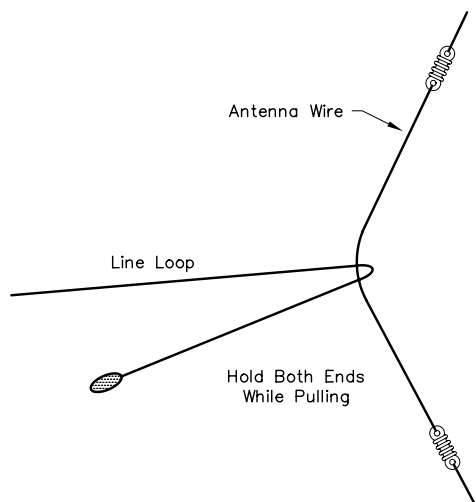
Needless to say, any of the suggested methods should be used with due respect to persons or property in the immediate vicinity. A child's sponge-rubber ball (baseball size) makes a safe weight for heaving a heavy thread line or fishing line.

If the antenna wire snags in the lower branches of the tree when the wire is pulled up, or if other trees interfere with raising the antenna, a weighted line thrown over the antenna and slid to the appropriate point is often helpful in pulling the antenna wire to one side to clear the interference as the antenna is being raised. This is shown in **Fig 3**.

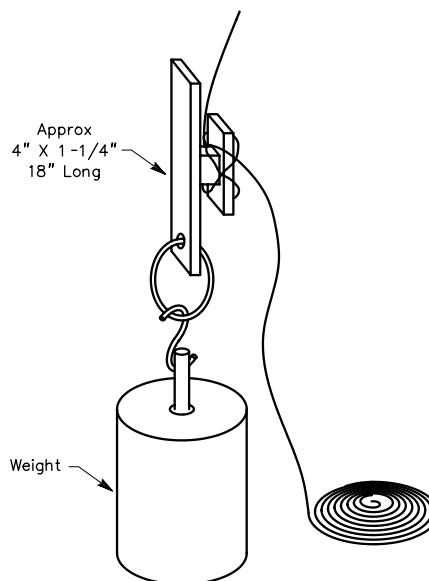


**Fig 2—In connecting the halyard to the pilot line, a large knot that might snag in the crotch of a tree should be avoided, as shown.**





**Fig 3—A weighted line thrown over the antenna can be used to pull the antenna to one side of overhanging obstructions, such as tree branches, as the antenna is pulled up. When the obstruction has been cleared, the line can be removed by releasing one end.**



**Fig 4—The cleat eliminates the need to untie a knot that may be weather hardened.**

### Wind Compensation

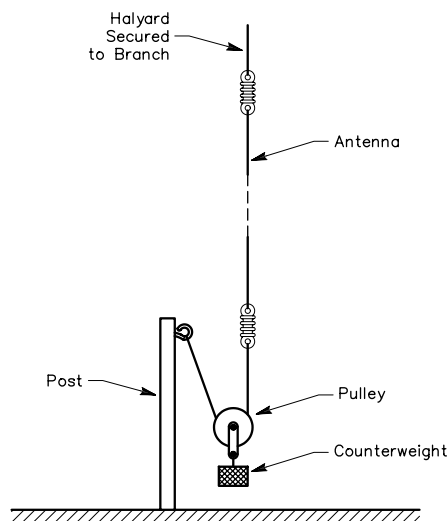
The movement of an antenna suspended between supports that are not stable in the wind can be reduced by the use of heavy springs, such as screen-door springs under tension, or by a counterweight at the end of one halyard. This is shown in Fig 1. The weight, which may be made up of junkyard metal, window sash weights, or a galvanized pail filled with sand or stone, should be adjusted experimentally for best results under existing conditions. Fig 4 shows a convenient way of fastening the counterweight to the halyard. It eliminates the necessity for untying a knot in the halyard, which may have hardened under tension and exposure to the weather.

### TREES AS SUPPORTS FOR VERTICAL WIRE ANTENNAS

Trees can often be used to support vertical as well as horizontal antennas. If the tree is tall and has overhanging branches, the scheme of Fig 5 may be used. The top end of the antenna is secured to a halyard passed over the limb, brought back to ground level, and fastened to the trunk of the tree.

### MAST MATERIALS

Where suitable trees are not available, or a more stable support is desired, light-duty guyed masts are suitable for wire antennas of reasonable span length. At one time, most amateur masts were constructed of lumber, but the TV industry has brought out metal masts that are inexpensive and much more durable than wood. However, there are some applications where wood is necessary or desirable.



**Fig 5—Counterweight for a vertical antenna suspended from an overhanging tree branch.**

### A Ladder Mast

A temporary antenna support is sometimes needed for an antenna system for antenna testing, site selection, emergency exercises or Field Day. Ordinary aluminum extension ladders are ideal candidates for this service. They are strong, light, extendable, weatherproof and easily transported. Additionally, they are readily available and can be returned to normal use once the project is concluded. A ladder tower will support a lightweight triband beam and rotator.

With patience and ingenuity one person can erect this assembly. One of the biggest problems is holding the base down while “walking” the ladder to a vertical position. The ladder can be guyed with 1/4-inch polypropylene rope. Rope guys are arranged in the standard fashion with three at each level. If help is available, the ladder can be walked up in its retracted position and extended after the antenna and rotator are attached. The lightweight pulley system on most extension ladders is not strong enough to lift the ladder extension. This mechanism must be replaced (or augmented) with a heavy-duty pulley and rope. Make sure when attaching the guy ropes that they do not foul the operation of the sliding upper section of the ladder. There is one hazard in this system that must be avoided: Do not climb or stand on the ladder when it is being extended—even as much as one rung. Never stand on the ladder and attempt to raise or lower the upper section. Do all the extending and retracting with the heavy-duty rope and pulley!

If the ladder is to be raised by one person, use the following guidelines. First, make sure the rung-latching mechanism operates properly before beginning. The base must be hinged so that it does not slip along the ground during erection. The guy ropes should be tied and positioned in such a way that they serve as safety constraints in the event that control of the assembly is lost. Have available a device (such as another ladder) for supporting the ladder during rest periods. (See Fig 6.)

After the ladder is erect and the lower section guys tied and tightened, raise the upper portion one rung at a time. Do not raise the upper section higher than it is designed to go; safety is far more important than a few extra feet of height.

For a temporary installation, finding suitable guy anchors can be an exercise in creativity. Fence posts, trees, and heavy pipes are all possibilities. If nothing of sufficient strength is available, anchor posts or pipes can be driven



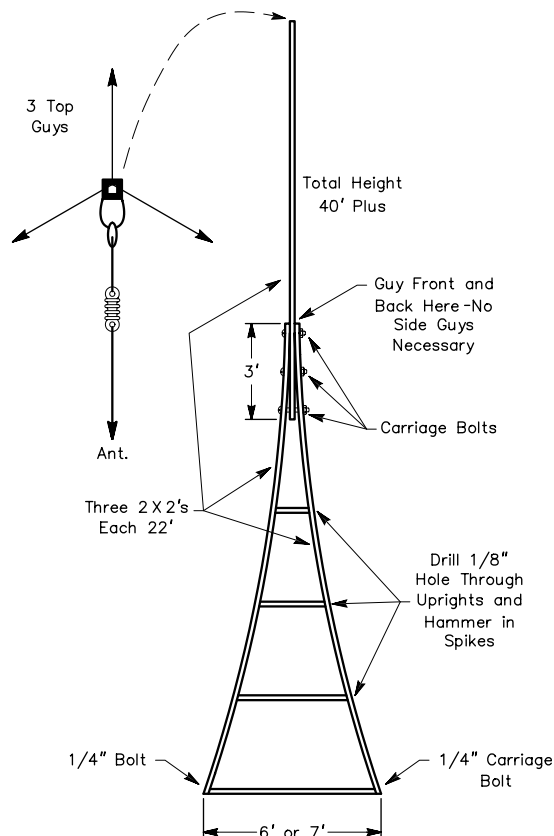
**Fig 6—Walking the ladder up to its vertical position. Keith, VE2AQU, supports the mast with a second ladder while Chris, VE2FRJ, checks the ropes. (Photo by Keith Baker, VE2XL)**

into the soil. Sandy soil is the most difficult to work with because it does a very poor job of holding anchors. A discarded car axle can be driven into the ground as an anchor, as its mass and strength are substantial. A chain and car-bumper jack can be used to remove the axle when the operation is done.

Above all else, keep the tower and antenna away from power lines. Make sure that nothing can touch the lines if the assembly falls. Disassemble by reversing the process. Ladder towers are handy for “quickie” antenna supports, but as with any improvisation of support materials, care must be taken to ensure safe construction.

### The A-Frame Mast

A light and relatively inexpensive mast is shown in Fig 7. In lengths up to 40 feet it is very easy to erect and will stand the pull of ordinary wire antenna systems. The lumber used is 2 × 2-inch straight-grained pine (which many lumber yards know as hemlock) or even fir stock. The uprights can be as long as 22 feet each (for a mast slightly over 40 feet high) and the cross pieces are cut to fit. Four pieces of 2 × 2 lumber, each 22 feet long, provides more than



**Fig 7—The A-frame mast is lightweight and easily constructed and erected.**

enough. The only other materials required are five 1/4-inch carriage bolts 5 1/2 inches long, a few spikes, about 300 feet of stranded or solid galvanized wire for guying, enough glazed porcelain compression (“egg”) insulators to break up the guys into sections, and the usual pulley and halyard rope. If the strain insulators are put in every 20 feet, approximately 15 of them will be enough.

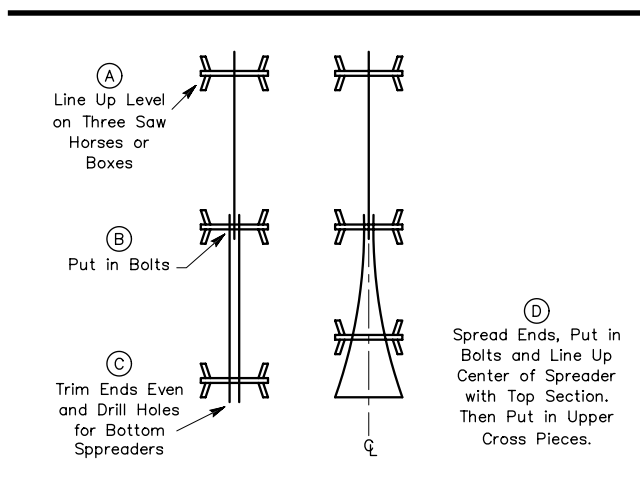
After selecting and purchasing the lumber—which should be straight-grained and knot-free—sawhorses or boxes should be set up and the mast assembled as shown in **Fig 8**. At this stage it is wise to give the mast a coat of primer and a coat of outside white latex paint.

After the coat of paint is dry, attach the guys and rig the pulley for the antenna halyard. The pulley anchor should be at the point where the top stays are attached so the backstay will assume the greater part of the load tension. It is better to use wire wrapped around the mast with a small through-bolt to prevent sliding down than to use eyebolts.

If the mast is to stand on the ground, a couple of stakes should be driven to keep the bottom from slipping. At this point the mast may be “walked up” by a helper. If it is to go on a roof, first stand it up against the side of the building and then hoist it, from the roof, keeping it vertical. The whole assembly is light enough for two men to perform the complete operation—lifting the mast, carrying it to its permanent berth, and fastening the guys with the mast vertical. It is entirely practical to put up such a mast on a flat area of roof that would be too small to erect a regular tower installation, one that had to be raised vertically on the same spot.

### TV Mast Material

TV mast is available in 5- and 10-foot lengths, 1 1/4 inches diameter, in both steel and aluminum. These sections are crimped at one end to permit sections to be joined together. A form that is usually more convenient is the telescoping mast available from many electronic supply



**Fig 8—Method of assembling the A-frame mast on sawhorses.**

houses. The masts may be obtained with three, four or five 10-foot sections, and come complete with guying rings and a means of locking the sections in place after they have been extended. These masts are inherently more suitable for guyed mast installations than the non-telescoping type because the diameters of the sections increase toward the bottom of the mast. For instance, the top section of a 50-foot mast is 1 1/4 inches diameter, and the bottom section is 2 1/2 inches diameter.

Guy rings are provided at 10-foot intervals, but guys may not be required at every point. Guying is essential at the top and at least one other place near the center of the mast. If the mast has any tendency to whip in the wind, or to bow under the load of a horizontal wire antenna, additional guys should be added at the appropriate points.

### MAST GUYING

Three guy wires in each set are usually adequate for a mast. These should be spaced equally round the mast. The required number of sets of guys depends on the height of the mast, its natural sturdiness (or stiffness), and the required antenna tension. A 30-foot-high mast usually requires two sets of guys, and a 50-foot mast needs at least three sets. One guy of the top set should be anchored to a point directly opposing the force exerted by the wire antenna. The other two guys of the same set should be spaced 120° with respect to the first, as shown in the inset in **Fig 7**.

Generally, the top guys should be anchored at distances from the base of the mast at least 60% of the mast height. The distance of the guy anchors from the mast determines the guy loads and the vertical load compressing the mast. At a 60% distance, the load on the guy wire opposite the wire antenna is approximately twice the antenna tension. The compression in the mast will be 1.66 times the antenna tension. With the anchors out 80% of the mast height, the guy tension will be 1.6 times larger than the antenna load and the mast compression will be 1.25 times larger.

Whenever possible, the largest available anchor spacing should be used. The additional compression on the mast, due to closer anchor spacing, increases the tendency of the mast to buckle. Buckling occurs when the compression on the unsupported spans between guys become too great for the unsupported length. The section then bows out laterally and will usually fold over, collapsing the mast. Additional sets of guys reduce the tendency for the mast to buckle under the compression by decreasing the unsupported span lengths and stabilizing the mast, keeping it in a straight line.

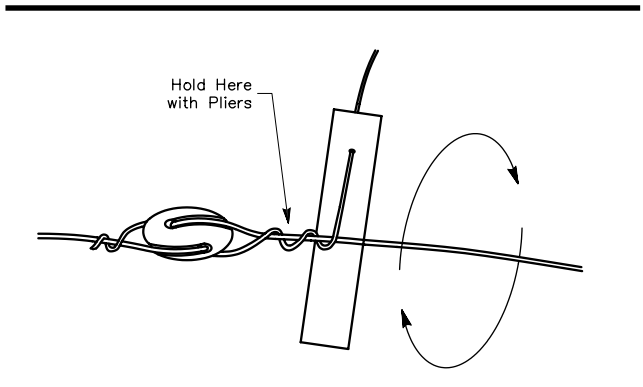
A natural phenomenon, called *vortex shedding*, can occur when the wind passes over the sections of a guyed mast. For every section size, shape, and length, there is a wind speed that can cause the sections to oscillate mechanically. When all the sections of an antenna support mast are close to the same size and length, it is possible for all of the mast sections to vibrate simultaneously between the guys. To reduce the potential for this, you can place the guys at locations along the mast that will result in different

span lengths. This creates different mechanical resonant frequencies for each span, eliminating the possibility of all sections oscillating at the same time.

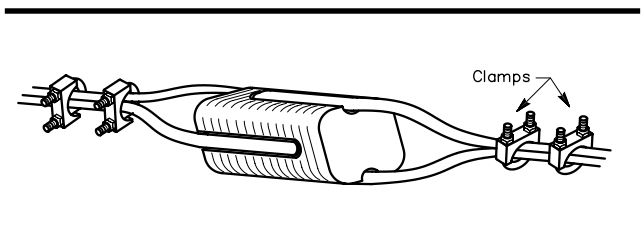
When determining the guy locations along the mast to treat this problem, you also need to consider the mast buckling requirements. Since the compression in the mast is greatest in the bottom span, and the least in the top span, the guys should be placed to make the bottom span the shortest and the top span the longest. A general guide for determining the different span lengths is to make the unguied lengths change by 10 to 20%.

Example: For a 30-foot high mast with three guy sets, the equal-guy locations would be every 10 feet. We can make the center span, 10 feet long, and then make the lower span 15% shorter and the top span 15% longer. While this is not an exact technical method to determine the best solution, the approach will create different mechanical resonant frequencies for the spans, with the span lengths approximately adjusted for the varying buckling requirements.

You can eliminate electrical resonance from conductive guy materials that might cause distortion of the antenna radiation pattern by breaking each guy into non-resonant lengths using strain insulators (see Figs 9 and 10). This subject is covered in detail later in this chapter.



**Fig 9—Simple lever for twisting solid guy wires when attaching strain insulators.**



**Fig 10—Stranded guy wire should be attached to strain insulators by means of standard cable clamps made to fit the size of wire used.**

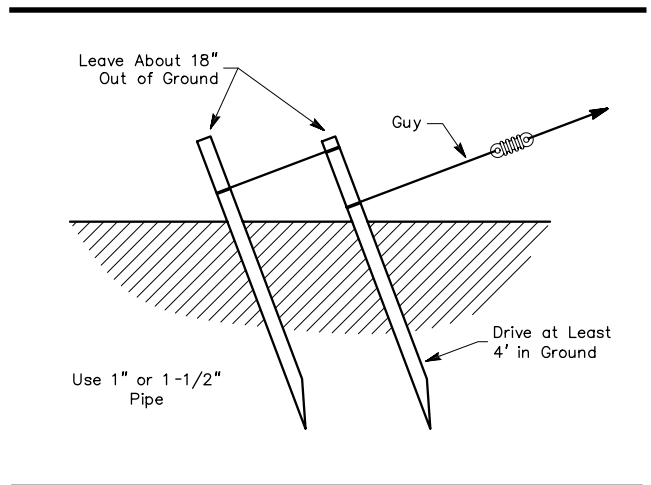
### Guy Material

When used within their safe load ratings, you may use any of the halyard materials listed in Chapter 20 for the mast guys. Nonmetallic materials have the advantage that there is no need to break them up into sections to avoid unwanted resonant interactions. All of these materials are subject to *stretching*, however, which causes mechanical problems in permanent installations. At rated working loads, dry manila rope stretches about 5%, while nylon rope stretches about 20%. Usually, after a period of wind load and wet/dry cycles, the lines will become fairly stable and require less frequent adjustment.

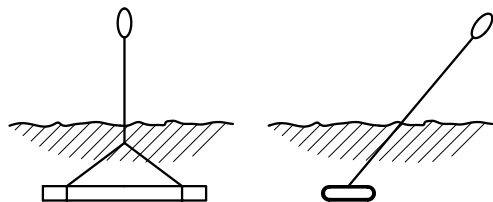
Solid galvanized steel wire is also widely used for guying. This wire has approximately twice the load ratings of similar sizes of copper-clad wire, but it is more susceptible to corrosion. Stranded galvanized wire sold for guying TV masts is also suitable for light-duty applications, but is also susceptible to corrosion. It is prudent to inspect the guys every six months for signs of deterioration or damage.

### Guy Anchors

Figs 11 and 12 show two different kinds of guy anchors. In Fig 11, one or more pipes are driven into the ground at right angles to the guy wire. If a single pipe proves to be inadequate, another pipe can be added in tandem, as shown, and connected with a galvanized steel cable. Heavy-gauge galvanized pipe is preferred for corrosion resistance. Steel fence posts may be used in the same manner. Fig 12 shows a *dead-man* type of anchor. The buried anchor may consist of one or more pipes 5 or 6 feet long, or scrap automobile parts, such as bumpers or wheels. The anchors should be buried 3 or 4 feet in the ground. The cable connecting the dead-man to the guys should be galvanized wire rope, like EHS guy cable. You should coat the buried part of the cable



**Fig 11—Driven guy anchors. One pipe is usually sufficient for a small mast. For added strength, a second pipe may be added, as shown.**



**Fig 12—Buried *dead-man* guy anchor (see text).**

with roofing tar, and thoroughly dry it prior to burial to enhance resistance to corrosion.

Also available are some heavy auger-type anchors that screw into the earth. These anchors are usually heavier than required for guying a mast, although they may be more convenient to install. You should conduct annual inspections of the anchors by digging several inches below grade around the anchor to inspect for corrosion.

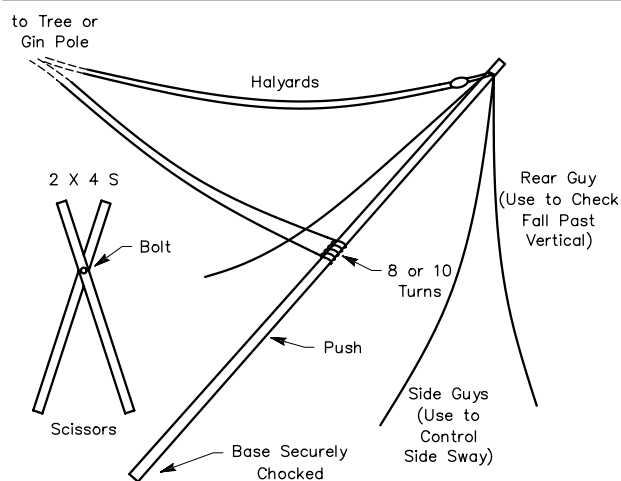
Trees and buildings may also be used as guy anchors if they are located appropriately. Care should be exercised, however, to make sure that the tree is of adequate size and that any fastening to a building can be made sufficiently secure.

### Guy Tension

Many troubles encountered in mast guying are a result of pulling the guy wires too tight. Guy-wire tension should never be more than necessary to correct for obvious bowing or movement under wind pressure. Approximately 10% to 15% of the working load is sufficient. In most cases, the tension needed does not require the use of turnbuckles, with the possible exception of the guy opposite a wire antenna. If any great difficulty is experienced in eliminating bowing from the mast, the guy tension should be reduced or additional sets of guys are required. The mast should be checked periodically, especially after large wind events, to ensure the guys and anchors have not stretched or moved, allowing the mast to get away from the required straight alignment.

### ERECTING A MAST OR OTHER SUPPORT

Masts less than 30 feet high usually can be simply walked up after blocking the bottom end securely. Blocking must be done so that the base can neither slip along the ground nor upend when the mast is raised. An assistant should be stationed at each guy wire, and may help by pulling



**Fig 13—Pulling on a gin line fastened slightly above the center point of the mast and on the halyards can assist in erecting a tall mast. The tensions should be just enough to keep the mast in as straight a line as possible. The “scissors” may be used to push on the under side and to serve as a rest if a pause in raising becomes necessary.**

the proper guy wire as the mast nears the vertical position. Halyards can be used in the same manner.

As the mast is raised, it may be helpful to follow the underside of the mast with a scissor rest (**Fig 13**), should a pause in the hoisting become necessary. The rest may also be used to assist in the raising if an assistant mans each leg.

As the mast nears the vertical position, those holding the guy wires should be ready to temporarily fasten the guys to prevent the mast from falling. The guys can then be adjusted until the mast is perfectly straight.

For masts over 30 feet long, a *gin pole* of some form may be required, as shown in Fig 13. Several turns of rope are wound around a point on the mast above center. The ends of the rope are then brought together and passed over a tree limb. The rope should be pulled as the mast is walked up to keep the mast from bending at the center. If a tree is not available, a post, such as a 2 × 4, temporarily erected and guyed, can be used. After the mast has been erected, the assisting rope can be removed by walking one end around the mast (inside the guy wires).

Telephone poles and towers are much sturdier supports. Such supports may require no guying, but they are not often used solely for the support of wire antennas because of their relatively high cost. For antenna heights in excess of 50 feet, however, they are usually a most practical form of support.

# Tower And Antenna Selection and Installation

The selection of a tower, its height, and the type of antennas and rotator is probably one of the more complex issues faced by station builders. All aspects of the tower, antenna, and rotator system are interrelated, and you should consider the overall system before making any decisions regarding specific system components.

Perhaps the most important consideration for many amateurs is the effect of the antenna system on the surrounding environment. If plenty of space is available for a tower installation and if there is little chance of causing esthetic distress on the part of family members or the neighbors, the amateur is indeed fortunate. Often, the primary considerations are purely financial. For most, however, the size of the property, the effect of the system on others, local ordinances, and the proximity of power lines and poles influence the selection of the tower/antenna system considerably.

The amateur must consider the practical limitations for installation. Some points for consideration are given below:

- 1) A tower should not be installed in a position where it could fall onto a neighbor's property.
- 2) The antenna must be located in such a position that it cannot possibly tangle with power lines, either during normal operation or if the structure should fall.
- 3) Sufficient yard space must be available to position a guyed tower properly. The guy anchors should be between 60% and 80% of the tower height in distance from the base of the tower on level ground—sloping terrain may require larger areas.
- 4) Provisions must be made to keep children from climbing the support. (Poultry netting around the tower base will serve this need.)
- 5) Local ordinances should be checked to determine if any legal restrictions affect the proposed installation.

Other important considerations are (1) the total dollar amount to be invested, (2) the size and weight of the antenna desired, (3) the climate, and (4) the ability of the owner to climb a fixed tower.

Most tower manufacturers provide catalogues or data packages that represent engineered tower configurations. These are provided as a convenience for users to help determine the most suitable tower configurations. The most commonly used design specifications for towers are [EIA \(Electronic Industries Assoc.\) RS-222](#) and [UBC \(Uniform Building Code\)](#). These specifications define how the tower, antenna, and guy loads are determined and applied to the system, and establish general design criteria for the analysis of the tower. Local authorities often require the review and approval of the installation by a state licensed Professional Engineer (P.E.) to obtain building permits. All local authorities in the United States do not subscribe to the same design standards, so often the manufacturers' general-purpose engineering is not applicable.

One of the first things you need to determine in the tower

selection process is the type of specification required by the local authorities, if any. Then, you must determine the *Basic Wind Speed* appropriate for the site. The Basic Wind Speed used in most specifications is the average wind speed for one mile of wind passing across the structure. It will be a lower value than the peak readings from an anemometer (wind gauge) installed at the site. For example, a Basic Wind Speed of 70 mph could have a maximum value of 80 mph and a minimum of 60 mph, equally distributed during the passage of the mile of wind. Basic wind speeds can be found in tables or maps contained in the appropriate specifications. Often, the basic wind speed used for the location may be obtained from the local permit authority. Check out the Web site at <http://www.championradio.com>, which contains EIA basic wind speed tables for every county in the USA. UBC speeds are available at almost every local library.

Antenna manufacturers also provide antenna data to assist in the selection process. Unfortunately, antenna mechanical designs do not always follow the same design standards used for towers. Proper antenna selection often means that you must determine the antenna surface areas yourself to avoid overloading the tower. More discussion about this follows later in this chapter.

It is often very helpful to the novice tower installer to visit other local amateurs who have installed towers. Look over their hardware and ask questions. If possible, have a few local experienced amateurs look over your plans—before you commit yourself. They may be able to offer a great deal of help. If someone in your area is planning to install a tower and antenna system, be sure to offer your assistance. There is no substitute for experience when it comes to tower work, and your experience there may prove invaluable to you later.

## THE TOWER

Towers for supporting antennas come in a variety of different types. Each type has its own set of benefits and limitations, or conditions and requirements. Often, you can choose a particular tower type by considering issues other than pure mechanical performance. Understanding how each type of tower functions, and what their respective requirements are, are the first steps in making the best tower selection for your own situation.

### Guyed Towers

The most common variety of tower is the *guyed tower* made of identical stacked sections, supported by guy cables attached to ground anchors placed symmetrically around the tower. These towers are the most economical, in terms of feet per dollar investment, and are more efficient for carrying antenna loads than non-guyed towers.

The guys resist the lateral loads on the system created by the wind. Since the guys slope down to the ground, horizontal loads due to the wind result in vertical loads

applied to the tower at each tower/guy connection. The tower becomes a compression member, trying to resist the column compression generated by the guy reactions. A tower in compression can buckle, so the distance between guy connections along the tower is important.

### Tower Bases for Guyed Towers

Another important phenomenon in a guyed tower is stretching of the guy cables. All guys stretch under load and when the wind blows the elongated guys allow the tower to lean over somewhat. If the tower base is buried in the concrete footing—as is commonly done in amateur installations—the bending stress at the tower base can become a significant factor. Towers that have been installed with tapered pier-pin bases much more freely absorb tower leaning, and they are far less sensitive to guy-elongation problems.

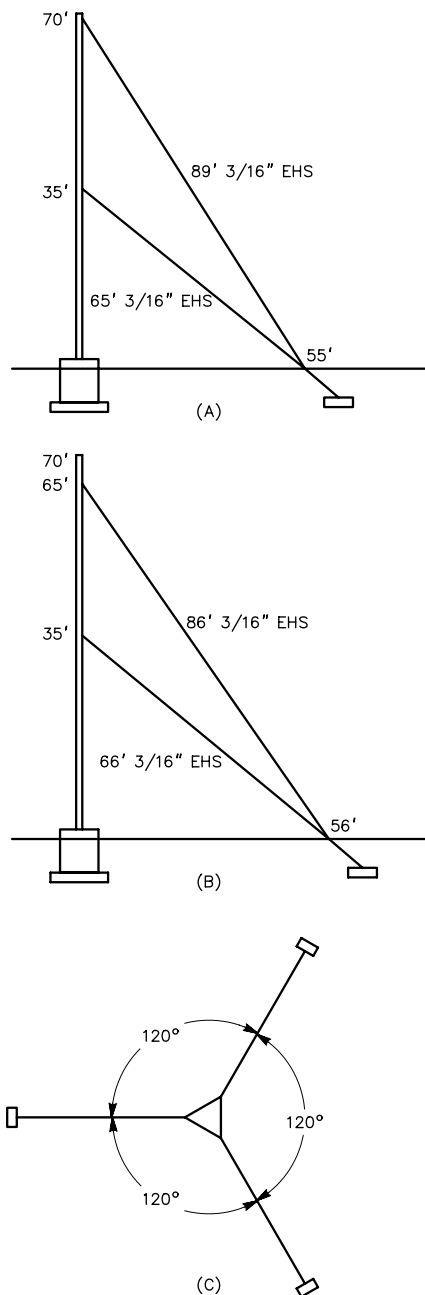
The tapered pier-pin tower installation is not without some drawbacks. These installations often require torque-arm guy brackets or six-guy torque-arm assemblies to control tower rotation due to antenna torque. They also require temporary guys when they are being installed to hold the base section steady until the permanent guys are mounted. Some climbers also don't like the flexing when they start to climb these types of towers.

On the positive side, pier-pin base towers have all structural members above the concrete footing, eliminating concerns about hidden corrosion that can occur with buried towers. Most decisions regarding the type of base installation are made according to the preference of the tower builder/maintainer. While either type of base configuration can be successfully used, you would be wise to do the stress calculations (or have a professional engineer do them) to ensure safety, particularly when large antenna loads are contemplated and particularly if guys that can easily stretch are used, such as Phillystran guys.

The configuration shown in **Fig 14A** is taken from an older (1983) Unarco-Rohn catalog. This configuration has the top set of guys placed at the top of the tower with the lower set halfway up the tower. This configuration is best for most amateur installations, which usually have the antennas mounted on a rotatable mast extending out the top of the tower—thereby placing the maximum lateral loads when the wind blows at the top of the tower (and the bottom of the rotating mast).

The configuration shown in **Fig 14B** is from a newer (1998) Rohn catalog. It has 5 feet of unsupported tower extending above the top guy set. The newer configurations are tailored for commercial users who populate the top region of the tower with fixed arrays and/or dishes. The installation in Fig 14B cannot safely withstand the same amount of horizontal top load as can the configuration shown in Fig 14A, simply because the guys start farther down from the top of the tower.

An overhead view of a guyed tower is given in Fig 14C. Common practice is to use equal angular spacings of 120° between guy wires. If you must deviate from this spacing,



**Fig 14—The proper method of installation of a guyed tower. At A, the method recommended for most amateur installations. At B, the method shown in later Rohn catalogs. This places considerable strain on the top section of the tower when large antennas are mounted on the tower.**

the engineering staff of the tower manufacturer or a civil engineer should be contacted for advice.

Amateurs should understand that most catalogs show generic examples of tower configurations that work within the cited design specifications. They are by no means the only solution for any specific tower/antenna configuration. You can usually substantially change the load capability of

any given tower by varying the size and number of guys. Station builders are encouraged to utilize the services of professional engineers to get the most out of their guyed towers. Those interested in more generic information about guyed tower behavior can find it at [www.freeyellow.com/members3/yagistress/](http://www.freeyellow.com/members3/yagistress/).

### Unguyed Towers

Another commonly used type of tower is not normally guyed—these are usually referred to as *freestanding* or *self-supporting* towers. Unguyed towers come in three different styles.

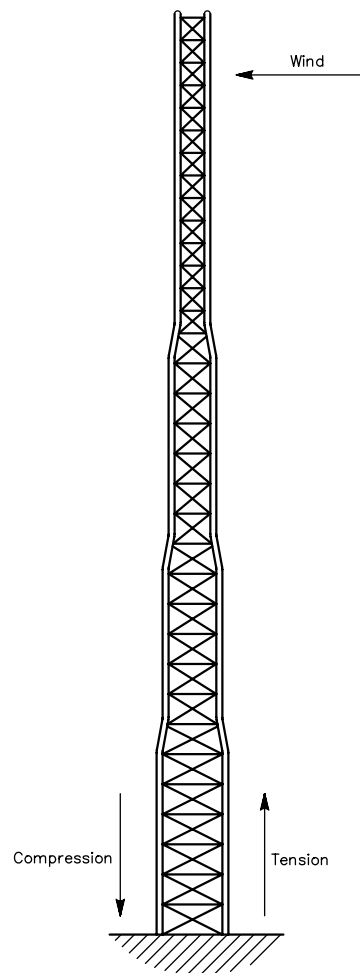
One style is comprised of stacked lengths of identical tower sections, just like those used for guyed towers. The only difference is that no guys are used. Manufacturers provide the recommended configurations and allowable loads for this type of installation in their catalogs. Unguyed towers are vastly less capable of supporting antenna loads than their guyed counterparts, but have great utility for light-duty applications—when configured within their capabilities.

The second style utilizes different tower section sizes, varying from large sections at the base and tapering down to smaller sections at the top. This style is more efficient for freestanding applications, because the tower is sized for the varying bending loads along the tower length, and is shown in **Fig 15**.

The third style of unguyed towers is commonly called a *crank-up tower*. It is a freestanding tower with telescoping sections that can be extended or retracted with a winch, cable, and pulley mechanism. This allows the tower to be raised and lowered for maintenance and antenna work. It is usually necessary to retract such towers for moderate to heavy winds. Some consider this a disadvantage because they can't operate their antennas at full height when it is windy. Two different forms of the crank-up style, freestanding tower are shown in **Fig 16**. Fig 16A shows the tubular version; Fig 16B shows the triangular space-frame version.

Some crank-up towers are used with guys and are only retracted for maintenance and antenna work. These towers are specially designed with locking mechanisms between the tower sections to carry the vertical compression created by the guys. *Do not* use guys with normal crank-up towers (those that have no locking devices between sections)! The increased tower compression will be carried by the hoisting cable, which will eventually cause it to fail.

Never climb a crank-up tower unless it is properly nested, with all load removed from the hoisting cable. For general antenna work, this can be accomplished by completely retracting it until the cable becomes loose. When servicing the rotator, the tower must be left partially extended. In this case every tower section must be blocked with heavy timber or thick-wall tubes, installed through the tower bracing, until all sections are resting on the blocks and the hoisting cable becomes slack. Safely installing the blocks in an extended crank-up tower can be challenging.

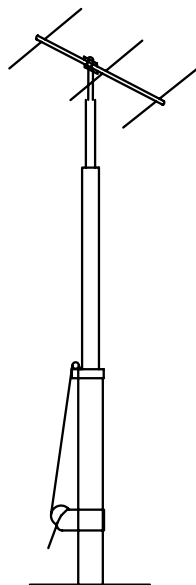


**Fig 15—Typical freestanding (unguyed) tower. Arrows indicate the directions of the forces acting upon the structure. See text for discussion.**

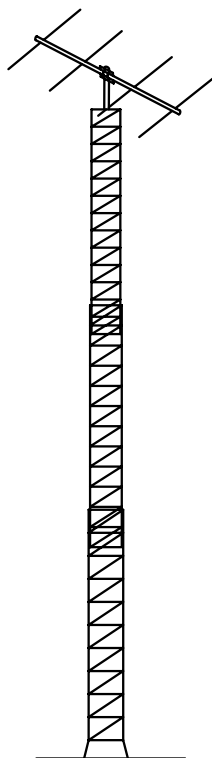
The object is to get all the blocks installed without a climber having to scale the unblocked tower, risking loss of limbs should the hoisting cable fail. An extension ladder, capable of reaching the required block elevations is the safest approach. If the necessary equipment or expertise is not available, the tower can be retracted, antennas removed, and leaned over, with the base tilt-over assembly, before extending it to access the rotator. Failure to properly block the tower before climbing can result in serious injury should the cable slip or break!

All freestanding towers share some unique characteristics. Each must support antenna and tower loads only by virtue of the bending strength of the tower sections and the tower footing connection to earth. Because of the large overturning moment at the tower base, freestanding towers require larger concrete footings than guyed towers. They are usually more expensive for the same load capability





(A)



(B)

Fig 16—Two examples of *crank-up* towers.

compared to guyed towers, simply because they require larger heavier tower sections and a larger footing to get the job done. The telescoping mechanisms in crank-up tower require more maintenance too.

Freestanding towers are quite popular, and are often the best solutions for sites with limited space and aesthetic concerns. When cranked down, a telescoping tower can maintain a low-profile system, out of sight of the neighbors and family.

### Tilt-Over Towers

Some towers have another convenience feature—a hinged section that permits the owner to fold over all or a portion of the tower. The primary benefit is in allowing antenna work to be done close to ground level, without the necessity of removing the antenna and lowering it for service. **Fig 17** shows a hinged base used with stacked, guyed tower sections. The hinged section can be designed for portions of the tower above the base. These are usually referred to as *guyed tilt-over towers*, where a conventional guyed tower can be tilted over for installing and servicing antennas. Many crank-up towers come with optional tilt-over base fixtures that are equipped with a winch and cable system for tilting the fully nested tower from horizontal to vertical positions.

Misuse of hinged sections during tower erection is a dangerously common practice among radio amateurs. Unfortunately, these episodes can end in accidents. If you do not have a good grasp of the fundamentals of physics, it might be wise to avoid hinged towers or to consult an expert if there are any questions about safely installing and using such a tower. It is often far easier (and safer) to erect a regular guyed tower or self-supporting tower with gin pole and climbing

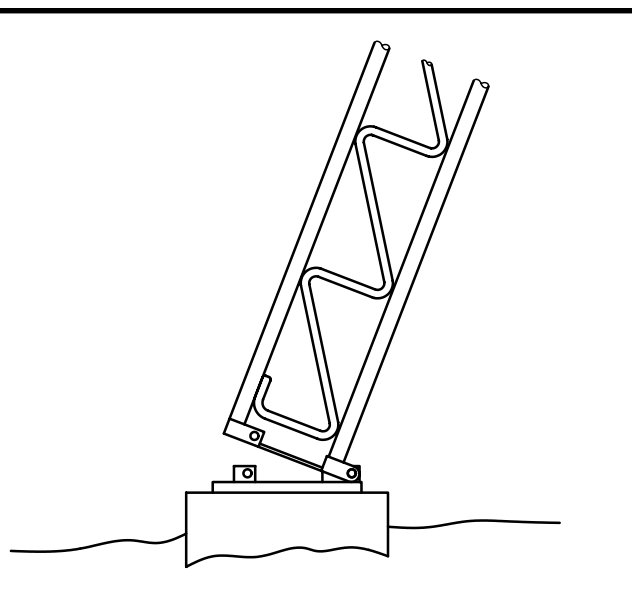


Fig 17—Fold-over or tilting base. There are several different kinds of hinged sections permitting different types of installation. Great care should be exercised when raising or lowering a tilting tower.

belt than it is to try to walk up an unwieldy hinged tower.

### The AB-577 Military Surplus Tower

Another light duty tower has found acceptance among many amateurs. The AB-577 system, available from assorted military surplus dealers, was designed to be a portable, rapid deployment antenna support for field communications. It is a guyed mast that goes up somewhat like a crank-up. The system consists of several short sections of aluminum tubing, with special end connections for joining them. These can be erected from the base fixture, which has a crank-up type winch-driven elevator platform. The tubing sections are installed in the base fixture and connected to the section above it with an over-center locking *Marmon*-style clamp. Then, the elevator platform is raised with the winch and the new tube is locked in place, high on the base fixture. Then the elevator is lowered to accept the next section. While the tower is extended, the supporting guys are adjusted via the unique *snubber* assemblies at the anchor connection. One person can erect this system, even in windy conditions, when special care is given to keeping the guys properly adjusted during each extension.

The standard AB-577 system, with 3 sets of guys, will support a modest triband Yagi at 45 feet. **Fig 18A** shows an installation with a Hy-Gain TH7DX at 45 feet.

### TOWER BASES

Tower manufacturers can provide customers with detailed plans for properly constructing tower bases. **Fig 19** is an example of one such plan. This plan calls for a hole that is  $3\frac{1}{2} \times 3\frac{1}{2} \times 6$  feet. Steel reinforcement bars are lashed together and placed in the hole. The bars are positioned so that they will be completely embedded in the concrete, yet will not contact any metallic object in the base itself. This is done to minimize the possibility of a direct discharge path for lightning through the base. Should such a lightning

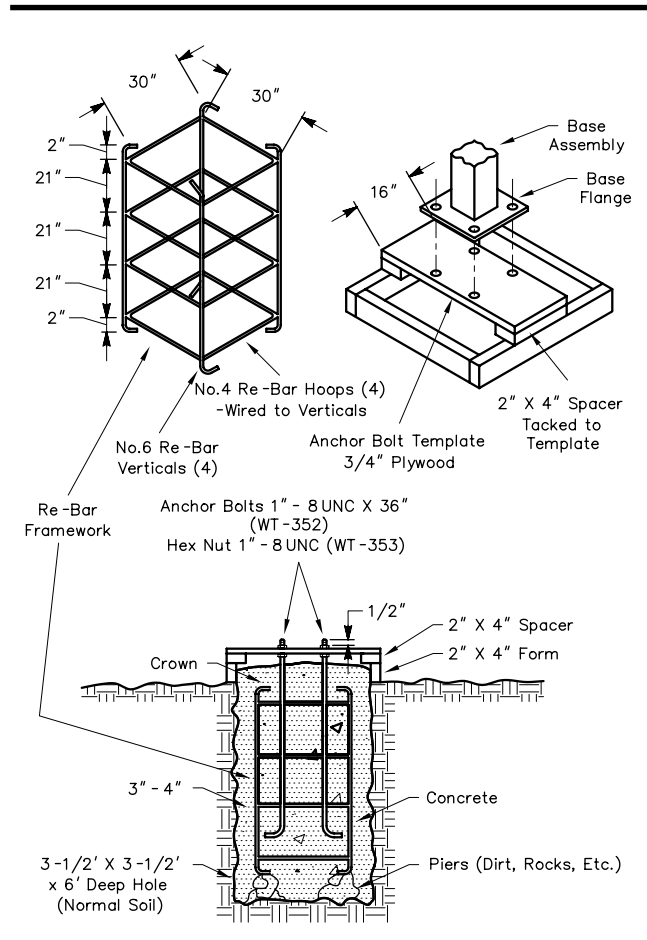


**Fig 18**—Installation of surplus AB-577 tower with triband at 45 feet at K7NV. (Photo by Kurt Andress, K7NV)

discharge occur, the concrete base could be damaged.

Providing suitable paths for the discharge of lightning energy safely for towers is a complex subject. Several companies offer products and guidance. The basic requirements for providing controlled discharge paths for lightning-induced current is to supply a low-impedance grid of conductors from the tower and feed lines to a field of interconnected ground rods around the base of the tower. Generally, the tower, station, and electrical service grounds need to be connected to prevent damaging potential differences from developing between the various components in the system.

A strong wooden form is constructed around the top of the hole. The hole and the wooden form are filled with concrete so that the resultant block will be 4 inches above grade. The anchor bolts are embedded in the concrete, and aligned with the plywood template, before it hardens. The template serves to align the anchor bolts to properly mate



**Fig 19**—Plans for installing concrete base for Wilson ST-77B tower. Although the instructions and dimensions vary from tower to tower, this is representative of the type of concrete base specified by most manufacturers.

with the tower itself. Once the concrete has cured, the tower base is installed on the anchor bolts and the base connection is adjusted to bring the tower into vertical alignment.

For a tower that bolts to a flat base plate mounted to the footing bolts (as shown in Fig 19), you can bolt the first tower section on the base plate to ensure that the base is level and properly aligned. Use temporary guys to hold things exactly vertical while the concrete cures. (The use of such temporary guys also works well when you place the first tower section in the base hole and plumb it vertically before pouring in the concrete.) Manufacturers can provide specific, detailed instructions for the proper mounting procedure. Fig 20 shows a slightly different design for a tower base.

The one assumption so far is that *normal* soil is predominant in the area in which the tower is to be installed. Normal soil is a mixture of clay, loam, sand and small rocks. More conservative design parameters for the tower base should be adopted (usually, using more concrete) if the soil is sandy, swampy or extremely rocky. If there are any doubts about the soil, the local agricultural extension office can usually provide specific technical information about the soil in a given area. When this information is in hand, contact the engineering department of the tower manufacturer or a civil engineer for specific recommendations with regard to compensating for any special soil characteristics.

### TOWER INSTALLATION

The installation of a tower is not difficult when the proper techniques are used. A guyed tower, in particular, is not hard to erect, because each of the individual sections is

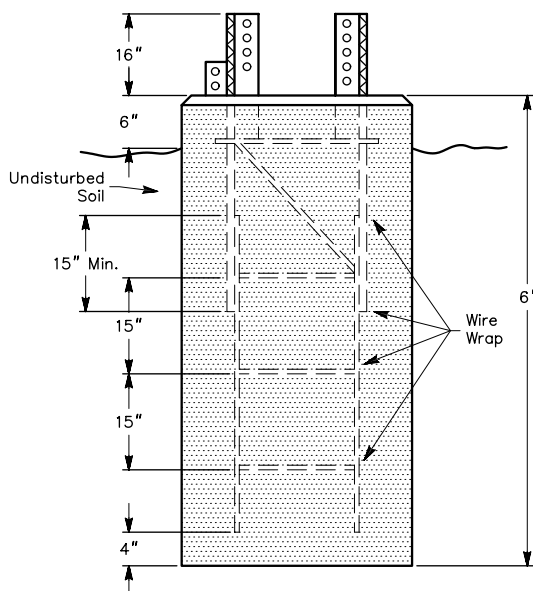


Fig 20—Another example of a concrete base (Tri-Ex LM-470).

relatively lightweight and can be handled with only a few helpers and some good quality rope. A *gin pole* is a necessity for raising and installing the tower sections. The gin pole shown in Fig 21 is designed to fit around a leg of the tower and clamps in place. The gin pole tube, which is about 12 feet long, has a pulley on the upper end. A rope is routed through the tubing and over the pulley. When the gin pole is attached to the tower and the tubing is extended into place and locked, the rope can be used to haul tower sections and/or antennas into place.

One of the most important aspects of any tower installation project is the safety of all persons involved. See Chapter 1 for details on important safety issues. The use of hard hats is highly recommended for all assistants helping from the ground. Helpers should always stand clear of the tower base to prevent being hit by a dropped tool or hardware. Each person working on the tower must use a good climber's safety belt.

When climbing the tower, if more than one person is involved, one should climb into position before the other begins climbing. The same procedure is required for climbing down a tower after the job is completed. The purpose is to have the non-climbing person stand still so as not to drop any tools or objects on the climbing person, or unintentionally obstruct his movements. When two persons are working on top of a tower, only one should change



Fig 21—A gin pole is helpful in positioning antennas and tower sections. The ground crew holds the weight of the assembly with a heavy rope, making tower work safer and less tiring. (Photo by Dave Pietraszewski, K1WA)

position (unbelt and move) at a time.

For most installations, a good-quality 1/2-inch diameter Manila hemp rope can adequately handle the workload for the hoisting tasks. The rope must be periodically inspected to assure that no tearing or chafing has developed, and if the rope should get wet from rain, it should be hung out to dry at the first opportunity. The knots used for connecting hoisting lines and hardware are critical to executing any safe installation, and special attention should be given to this detail for any work party.

Here is an important point regarding safety—the person who climbs the tower should be in charge of what happens with the ground crew. Not only does the person on the tower have a better overall view of the situation below, but also any confusion on the ground can result in serious injury to the climber.

### GUY WIRES

In typical guyed tower installations, guy wires may experience loads in excess of 1000 pounds. Since the guys are the primary means of carrying the horizontal wind loads, great care should be taken in their selection and installation.

Guys come in a variety of materials and constructions. Normally, the tower manufacturer or professional engineer will specify the size and type of cable to be used. The most common type of cable used for tower guying is the EHS (Extra High Strength) galvanized steel cable. The EHS cables are very stiff and are the highest strength cables in the wire rope family. Other steel cables are made to be more flexible for running around pulleys. While these are easier to work with when assembling, they are not as strong as the EHS type, and should be avoided for tower guying. Non-conductive guys, such as *Phillystran* or *pultruded* fiberglass rod have become popular for eliminating resonant interaction with antennas.

*Do not attempt to use cheaper cables that don't meet or exceed the criteria for those specified for your installation. Using the wrong cable, or failing to install the cable properly can have disastrous results! Table 1 shows data for several*

cables commonly used for tower guying. It is important to note that the minimum breaking strength of the various cables are independent of their elongation (stretch) under load.

### Guy Cable Installation

Figs 22 and 23 show methods for tensioning and safety wiring guy-wire turnbuckles. Fig 24 shows the traditional method for fixing the end of a steel guy wire. A thimble is used to prevent the wire from breaking because of a sharp bend at the point of intersection. Conventional wisdom strongly recommends the use of thimbles that are at least one wire size larger than the cable to provide a more gentle wire bend radius. Three cable clamps follow to hold the wire securely. Be sure to follow the note in Fig 24 for which part of the clip bears against the live (loaded) cable. As a final backup measure, the individual strands of the free end are unraveled and wrapped around the guy wire. It is a lot of work, but it is necessary to ensure a safe and permanent connection.

Fig 25 shows the use of a device that replaces the clamps and twisted strands of wire. These devices are known



**Fig 22—Proper tension can be placed on the guy wires with the aid of a block-and-tackle system. (Photo by K1WA)**

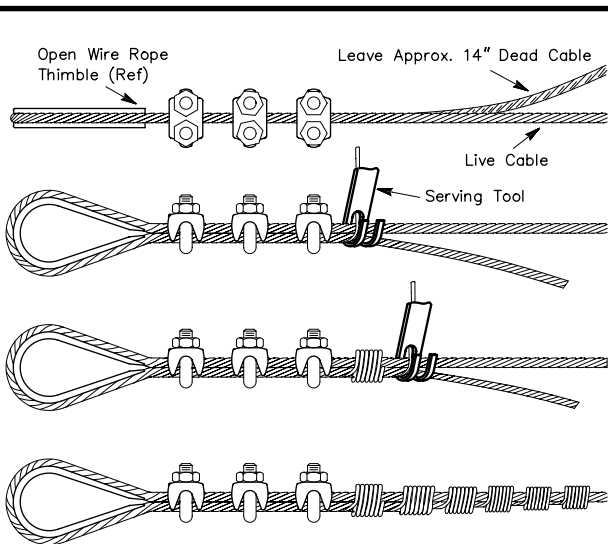
**Table 1  
Guy Cable Comparisons**

<i>Cable</i>	<i>Nominal Dia. Inches</i>	<i>Breaking Strength Lbs</i>	<i>Weight Lbs/100'</i>	<i>Elongation Inches/100'</i>	<i>%Elongation</i>
3/16" 1 × 7 EHS	0.188	3990	7.3	6.77	0.56%
1/4" 1 × 7 EHS	0.250	6700	12.1	3.81	0.32%
HPTG6700	0.220	6700	3.1	13.20	1.10%
HPTG8000	0.290	8000	3.5	8.90	0.74%
5/16" 1 × 7 EHS	0.313	11200	20.5	2.44	0.20%
HPTG11200	0.320	11200	5.5	5.45	0.45%
3/8" Fiberglass Rod	0.375	13000	9.7	5.43	0.45%

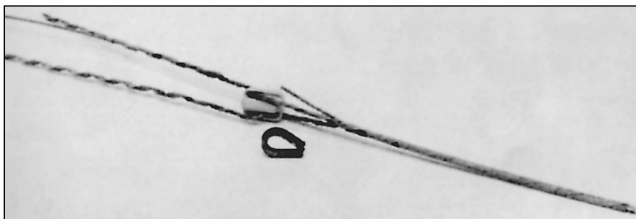
EHS steel cable information is taken from ASTM A 475-89, the industry standard specification for steel wire rope. The HPTG listings are for *Phillystran* aramid cables, and are based on the manufacturers' data sheets. The elongation (stretch) values are for 100 feet of cable with a 3000-pound load.



**Fig 23—A length of guy cable is used to assure that the turnbuckles remain in place after they are tightened. This procedure is an absolute requirement in guyed tower systems. (Photo by K1WA)**



**Fig 24—Traditional method for securing the end of a guy wire.**

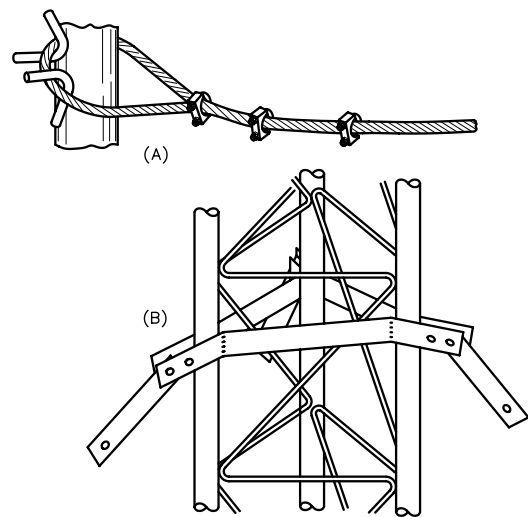


**Fig 25—Alternative method for attaching guy wires using *dead ends*. The dead end on the right is completely assembled (the end of the guy wire extends beyond the grip for illustrative purposes). On the left, one side of the dead end is partially attached to the guy wire. In front, a thimble is used where a sharp bend might cause the guy wire or dead end to break.**

as *dead ends*, *preformed guy grips*, or *Big Grips* and are commonly used on electrical power poles. They are far more convenient to use than are clamps, and are the recommended method for terminating Phillystran and fiberglass-rod guys. When using the guy grips, it is imperative that the recommended end sleeves are installed over the free end of the grip to prevent ice and falling hardware from sliding down the guy and unraveling the grip connection to the guy. The guy wires must be cut to the proper length. The dead end of each wire is installed into the object to which the guy wire is being attached (use a thimble, if needed to eliminate sharp cable bends). One side of the dead end is then wrapped around the guy wire. The other side of the dead end follows. Using dead ends saves time and trouble, more than making up for their slightly higher cost.

When using the non-conductive guy materials, it is highly recommended that a 25-foot length of EHS steel cable be used at the bottom for connection to the anchor. This serves a valuable purpose. The steel cable is more resistant to damage from ground activity and brush fires, and it is the preferred material for measuring cable pre-tension with commonly available devices.

**Fig 26** shows two different methods for attaching guy wires to towers. At Fig 26A, the guy wire is simply looped around the tower leg and terminated in the usual manner. At Fig 26B, a *guy bracket*, with *torque arms* has been added. Even if the torque arms are not required, it is preferred to use the guy bracket to distribute the load from the tower/guy connection to all three tower legs, instead of just one. The torque bracket is more effective resisting torsional loads on the tower than the simpler installation. Rohn offers another guy attachment bracket, called a *Torque Arm Assembly*, that allows six guys to be connected between the bracket and anchors. This is by far the best method of

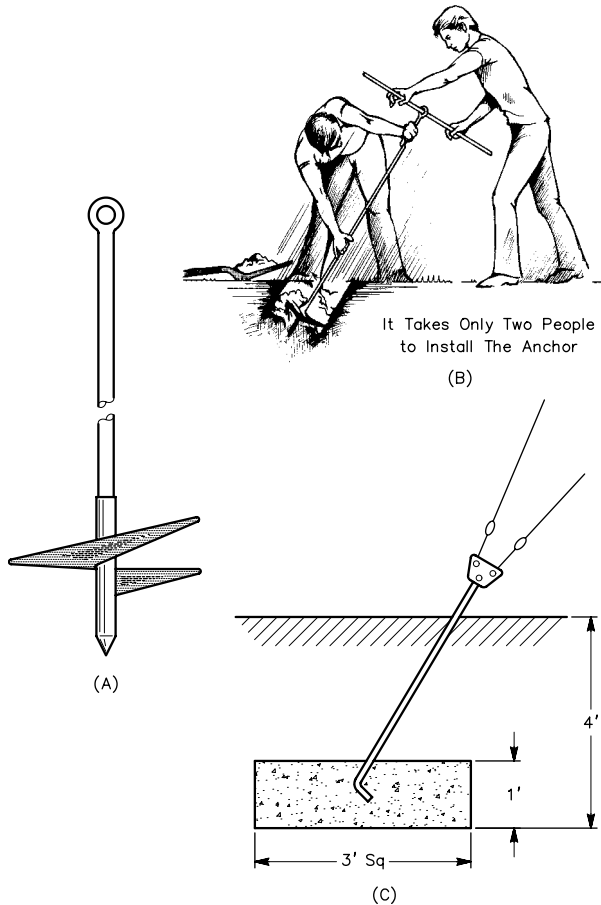


**Fig 26—Two methods of attaching guy wires to tower. See text for discussion.**

stabilizing a tower against high torque loads, and is recommended for installations with large antennas.

There are two types of commonly used guy anchors. **Fig 27A** depicts an *earth screw*. These are usually 4 to 6 feet long. The screw blade at the bottom typically measures 6 to 8 inches diameter. **Fig 27B** illustrates two people installing the anchor. The shaft is tilted so that it will be in line with the mean angle of all the guys connecting to the anchor. Earth screws are suitable for use in normal soil where permitted by local building codes. Information about *screw anchors* is available from the manufacturers of these devices. Information from a supplier specializing in this type of anchor can be found at <http://www.abchance.com>.

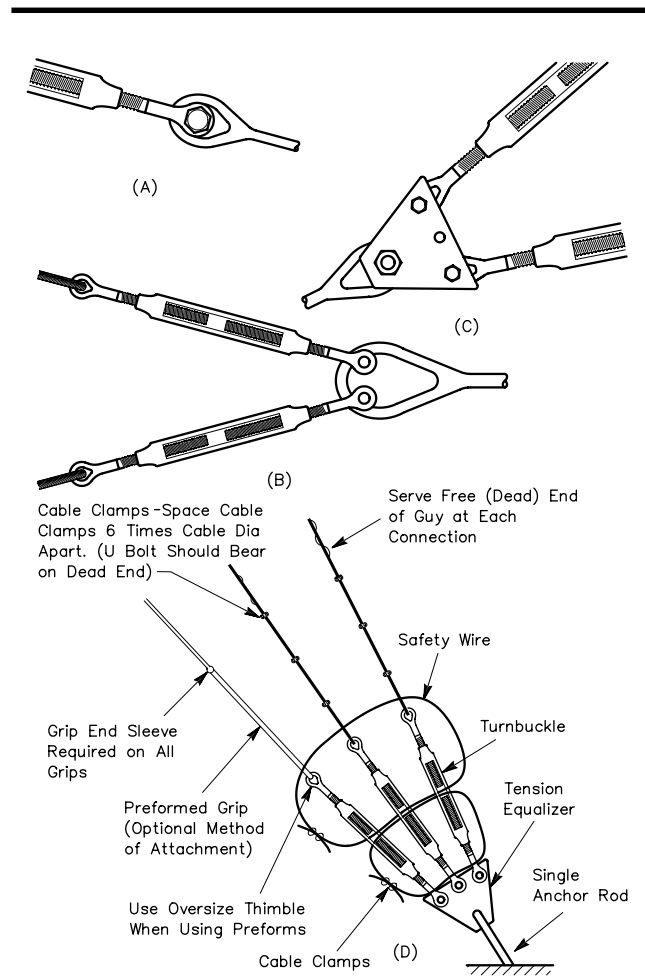
The alternative to earth screws is the concrete block anchor. **Fig 27C** shows the installation of this type of anchor; it is suitable for any soil condition, with the possible exception of a bed of lava rock or coral. Consult the instructions from the manufacturer, or your tower designer, for the precise anchor configuration.



**Fig 27—Two standard types of guy anchors. The earth screw shown at A is easy to install and widely available, but may not be suitable for use in certain soils. The concrete anchor is more difficult to install properly, but it is suitable for use with a wide variety of soil conditions and will satisfy most building code requirements.**

Turnbuckles and associated hardware are used to attach guy wires to anchors and to provide a convenient method for adjusting tension. **Fig 28A** shows a turnbuckle with a single guy wire attached to the eye of the anchor. Turnbuckles are usually fitted with either two eyes, or one eye and one jaw. The eyes are the oval ends, while the jaws are U-shaped with a bolt through each tip. **Fig 28B** shows two turnbuckles attached to the eye of an anchor. The procedure for installation is to remove the bolt from the jaw, pass the jaw over the eye of the anchor and reinstall the bolt through the jaw, through the eye of the anchor and through the other side of the jaw.

If two or more guy wires are attached to one anchor, *equalizer plates* should be installed (**Fig 28C**). In addition to providing a convenient point to attach the turnbuckles, the plates pivot slightly to equalize the various guy loads and produce a single load applied to the anchor. Once the installation is complete, a safety wire should be passed through the turnbuckles in a figure-eight fashion to prevent the turnbuckles from turning and getting out of adjustment (**Fig 28D**).



**Fig 28—Variety of means available for attaching guy wires and turnbuckles to anchors.**

All guyed towers require the guys to be installed with a certain amount of pre-tension. The tower manufacturer or designer specifies the required pre-tension values, which are usually 10% of the cable breaking strength. Pre-tension is necessary to eliminate looseness in the cable caused by the spiral wire construction and to eliminate excessive dynamic guy and tower motion under wind loading. The recommended method for adjusting the guys is to use a cable tension-measuring device such as the popular *Loos Guy Wire Tensioner*. The guy is gripped with a special clamp, such as the *Klein Cable Grip*, which is connected to the anchor below the eye (or equalizer plate) with a block and tackle arrangement (Fig 22) or a ratcheting come-along. Then the turnbuckle is adjusted to take up the load, the cable grip is released and the final guy tension is adjusted and checked.

When you adjust the guys at each level, you should check the tower for vertical alignment and straightness. This is often done with a transit from two ground points located 90° from each other.

### Resonance in Guy Wires

If guy wires are resonant at or near the operating frequency, they can receive and reradiate RF energy. By behaving as parasitic elements, the guy wires may alter and thereby distort the radiation pattern of a nearby antenna. For low frequencies where a dipole or other simple antenna is used, this is generally of little or no consequence. But at the

higher frequencies where a unidirectional antenna is installed, it is desirable to avoid pattern distortion if at all possible. The symptoms of re-radiating guy wires are usually a lower front to back ratio and a lower front to side ratio than the antenna is capable of producing. The gain of the antenna and the feed-point impedance will usually not be significantly affected, although sometimes changes in SWR can be noted as the antenna is rotated. (Of course other conductors in the vicinity of the antenna can also produce these same symptoms.)

The amount of re-radiation from a guy wire depends on two factors—its resonant frequency, and the degree of coupling to the antenna. Resonant guy wires near the antenna will have a greater effect on performance than those that are farther away. Therefore, the upper portion of the top level of guy wires should warrant the most attention with horizontally polarized arrays. The lower guy wires are usually closer to horizontal than the top level, but by virtue of their increased distance from the antenna, are not coupled as tightly to the antenna.

To avoid resonance, the guys should be broken up by means of egg or strain insulators. Fig 29 shows wire lengths that fall within 10% of  $\frac{1}{2}\lambda$  resonance (or a multiple of  $\frac{1}{2}\lambda$ ) for all the HF amateur bands. Unfortunately, no single length greater than about 14 feet avoids resonance in all bands. If you operate just a few bands, you can locate greater lengths from Fig 29 that will avoid resonance. For example, if you operate only the 14-, 21- and 24-MHz bands,

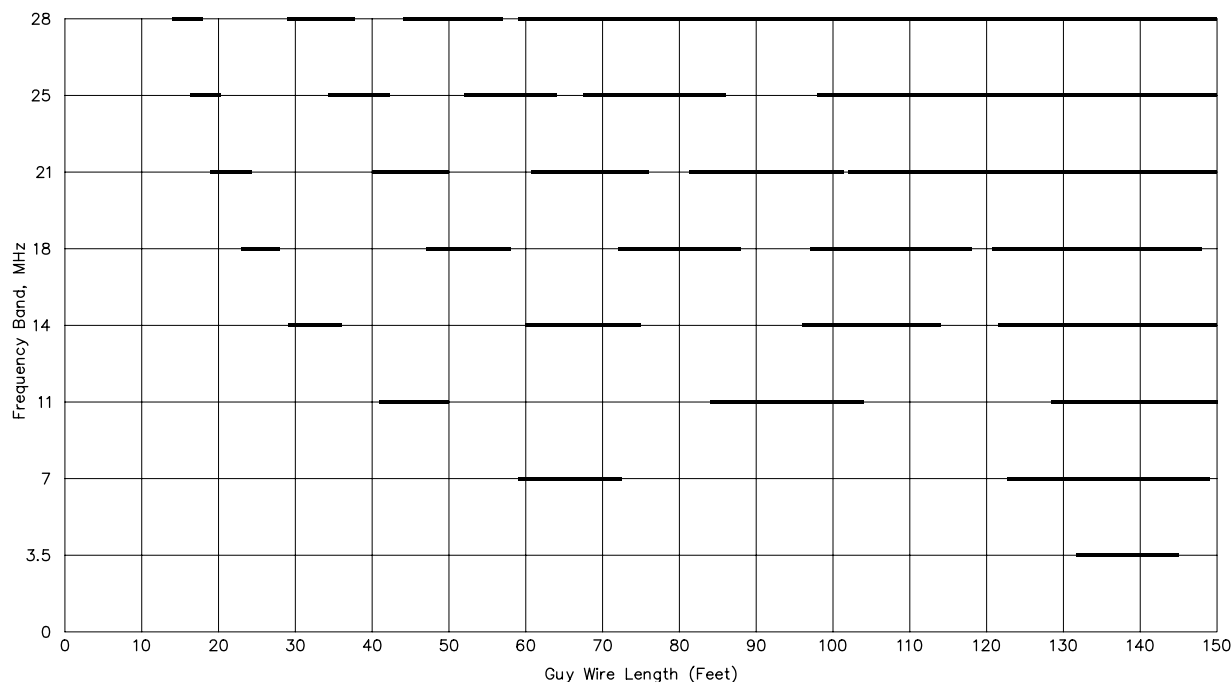


Fig 29—The black bars indicate ungrounded guy wire lengths to avoid for the eight HF amateur bands. This chart is based on resonance within 10% of any frequency in the band. Grounded wires will exhibit resonance at odd multiples of a quarter wavelength. (By Jerry Hall, K1TD)

guy wire lengths of 27 feet or 51 feet would be suitable, along with any length less than 16 feet.

## THE RIGHT TOWER FOR YOUR ANTENNA

Most manufacturers rate their towers in terms of the maximum allowable antenna load that can safely be carried at a specific wind speed. Ensuring that the specific antennas you plan to install meet the tower's design criteria, however, may not always be a straightforward task.

Most tower manufacturers rate the load in terms of *Flat Projected Area* (FPA). This is simply the equivalent area of a flat rectangular outline of the antenna members at right angles to the wind. Your tower calculations are done using the FPA but they must take into account the shape of the antenna members actually used (rectangular or tubular). Each shape results in different loads applied to the tower. Some tower manufacturers provide FPA values for each type of antenna construction, while others state a specific shape they intend. When the tower rating does not clearly identify whether the antenna is tubular or rectangular, you should contact the tower manufacturer to clarify the rating.

In the realm of antenna manufacturers, however, you may encounter another wind load rating called the *Effective Projected Area* (EPA). This attempts to take into account the actual shape of antenna elements. The problem is that there is no agreed-upon standard for the conversion from EPA to load numbers. Different manufacturers may use different conversion factors.

Since most tower manufacturers have provided FPA figures for their towers—allowing us in effect to ignore design-specification details—it would be easiest for us to work only with FPA values for our antennas. This would be fine, if indeed we had good FPA figures for the specific antennas we plan to use! Unfortunately, FPAs are rarely specified for commercially built amateur antennas. Instead, most antenna manufacturers provide effective areas in their specification sheets. You may need to contact the antenna manufacturer directly for the FPA antenna area or for the antenna dimensions so that you can do your own FPA calculations.

### Determining Antenna Areas

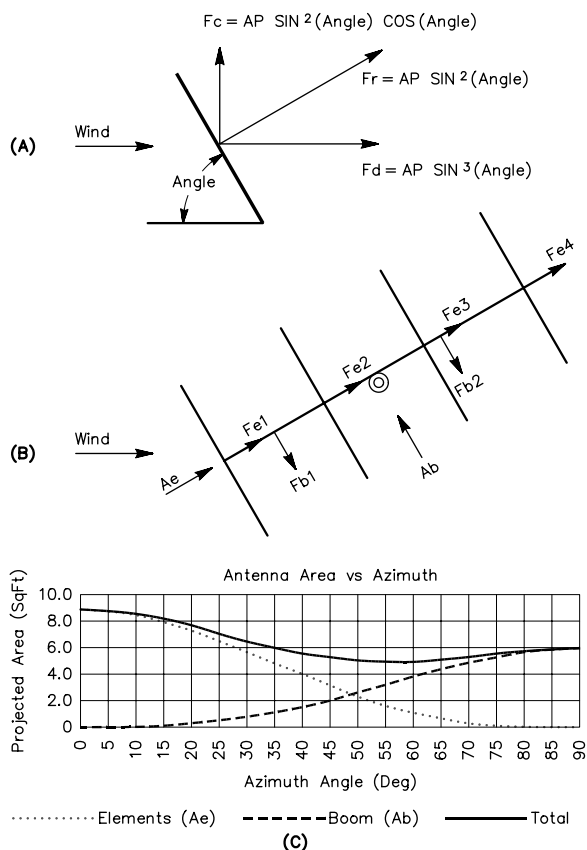
The method for determining the flat projected area of an antenna is quite simple. We'll use a Yagi antenna as an example. There are two worst-case areas that should be considered here. The first is the FPA of all the elements when the wind blows in the direction along the boom; that is, at right angles to the elements. The second FPA for a Yagi is when the wind is at right angles to the boom. One of these two orientations produces the worst-case exposed antenna area—all other wind angles present lower exposed areas. The idea is to take the highest of the FPAs for these two wind directions and call that the FPA of the antenna structure. See Fig 30.

The element FPA is calculated by multiplying each element's dimension of length by its diameter and then summing the FPAs for all elements. The boom's FPA is computed by multiplying the boom's length by its diameter.

The reason for considering two potential peak-load

orientations becomes clear when different frequency antennas are stacked on a mast or tower. Some antennas produce peak loads when the elements are broadside to the wind. This is typical of low-frequency Yagis, where the elements are long lengths of aluminum tubing. On the other hand, the boom can dominate the surface area computations in higher-frequency Yagis.

The fundamentals responsible for the need to examine both potential FPAs for Yagis relates to how wind flows over a structure and develops loads. Called *The Cross-Flow*



**Fig 30—Description of how loads are developed on a Yagi.** At A,  $F_r$  is the resultant force from the wind load on a generalized member.  $F_d$  is the load acting downwind (drag) that creates the load on the tower.  $F_c$  is the lateral component of the wind load. The term  $A$  is the flat projected area (FPA), which is the broadside area normal to the wind. The term  $P$  is the wind pressure. At B,  $A_e$  is the total element area, while  $A_b$  is the total boom area. All the loads due to the wind act normal to the antenna sections—the force on element #1 ( $F_{e1}$ ) acts along the axis of the boom, for example. At C, a plot of the *effective FPA* as a function of the azimuthal wind direction for a Yagi, ignoring drag coefficients. The Yagi in this example has 9.0 square feet of element FPA and 6.0 square feet of boom FPA. The worst-case FPAs occur with the beam pointed in the wind and with the boom broadside to the wind. To determine the actual tower loading, the actual drag coefficients and wind pressures must be used.



*Principle*, this was introduced to the communications industry by Dick Weber, K5IU, in 1993. The principle is based on the fact that the loads created by wind flowing across an antenna member only produce forces that are normal to (or perpendicular to) the major axis of the member. The resultant and component load calculations for this method are shown in Fig 30A.

For a Yagi, this means that wind forces on the elements act in-line with the boom, while forces on the boom act in-line with the elements. Fig 30B shows a force diagram for a typical Yagi. Fig 30C shows the FPA for a Yagi rotated through 90° of azimuth.

### Antenna Placement on the Mast/Tower

Another important consideration is where the antenna(s) will be placed on the tower. As mentioned before, most generic tower specifications assume that the entire antenna load is applied at the top of the tower. Most amateur installations have a tubular mast extending above the tower top, turned by a rotator mounted down inside the tower. Multiple Yagi antennas are often placed on the mast above the tower top, and you must make sure that both the tower and the mast can withstand the wind forces on the antennas.

For freestanding towers, you can determine how a proposed antenna configuration compares to the tower manufacturer's rating by using an *Equivalent Moment* method. The method computes the bending moment generated at the base of the tower by wind loads on the tower's rated antenna area located right at the top of the tower and compares that to the case when the antenna is mounted on a mast sticking out of the top of the tower.

The exact value of wind pressure is not important, so long as it is the same for both comparisons. The wind load on the tower itself can be ignored because it is the same in both comparisons and the drag coefficients for the antennas can also be ignored if all calculations are performed using flat projected antenna areas, as we've recommended previously.

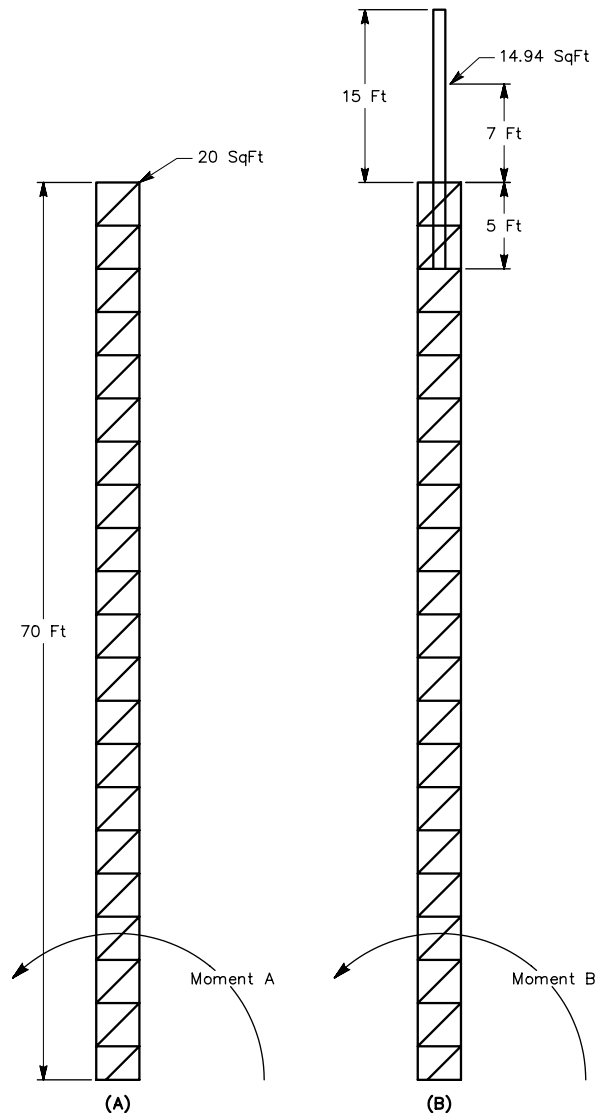
Keep in mind that this approach does not calculate *actual* loads and moments relevant to any specific tower design standard, but it does allow equivalent comparisons when the wind pressure is constant and all the antenna areas are of the same type. An example is in order.

**Fig 31A** shows a generic tower configuration, with a concentrated antenna load at the top of the tower. We'll assume that the tower manufacturer rates this tower at 20 square feet of flat projected antenna area. Fig 31B shows a typical amateur installation with a rotating mast and an antenna mounted 7 feet above the top of the tower. To make the calculations easy, we select a wind pressure of 1 pound per square foot (1 psf). This makes the tower base moment calculation for Fig 31A:

$$\text{Antenna load} = 20 \text{ feet}^2 \times 1 \text{ psf} = 20 \text{ pounds}$$

$$\text{Base moment} = 70 \text{ feet} \times 20 \text{ pounds} = 1400 \text{ foot-pounds.}$$

This is the target value for the comparison. An equivalent



**Fig 31**—At A, a 70-foot tower rated for 20 square feet of antenna load at the top. At B, the same tower with a 2-inch OD x 20-foot long mast, with an antenna mounted 7 feet above the top of the tower. Both configurations produce the same tower load.

configuration would produce the same base moment. For the configuration in Fig 31B, we assume a tubular 2-inch diameter mast that is 20 feet long, mounted 5 feet down inside the tower. Note that the lattice structure of the tower allows the wind to “see” the whole length of the mast and that we can consider the force distributed along the mast as being a single force concentrated at the mast's center. The flat projected area of the mast by itself, without the antenna, is:

$$\begin{aligned} \text{Mast area} &= 20 \text{ feet} \times 2 \text{ inches} / 12 \text{ inches/foot} \\ &= 3.33 \text{ square feet} \end{aligned}$$

The center of the mast is located at a height of 75 feet.

Using the same 1 psf wind load, the base bending moment due to the mast alone is:

$$\text{Base moment (due to mast)} = 3.33 \text{ feet}^2 \times 1 \text{ psf} \times 75 \text{ feet} \\ = 249.75 \text{ foot-pounds}$$

Including the mast in the configuration reduces the allowable antenna load. The remaining target base moment left for the antenna is found by subtracting the moment due to the mast from the original target value:

$$\text{New base target moment} = 1400 - 249.75 \text{ foot-pounds} = \\ 1150.25 \text{ foot-pounds.}$$

The antenna in Fig 31B is located at a height of 77 feet. To obtain the allowable antenna area at this elevation we divide the new base target moment by the antenna height, yielding an allowable antenna load of:

$$1150.25 \text{ foot-pounds} / 77 \text{ feet} = 14.94 \text{ pounds.}$$

Since we chose a wind load of 1 psf, the allowable antenna FPA has been reduced to 14.94 square feet from 20 square feet. If the projected area of the antenna we are planning to mount in the new configuration is less than or equal to this value, we have satisfied the requirements of the original design. You can use this equivalent-moment method to evaluate different configurations, even ones involving multiple antennas on the mast or situations with additional antennas placed along the tower below the tower top.

For guyed towers, the analyses become much more rigorous to solve. Because the guys and their behaviors are such a significant portion of the tower support mechanism, these designs can become very sensitive to antenna load placements. A general rule of thumb for guyed towers is never to exceed the original tower-top load rating, regardless of distributed loads along its length. Once you redistribute the antenna load placements along a guyed tower, you should do a fresh analysis, just to be sure.

You can run evaluations using the above method for antennas placed on the mast above a guyed tower top. The use of the Equivalent-Moment method for antennas mounted below the top of a guyed tower, however, can become quite suspect, since many generic tower designs have their intermediate guys sized for zero antenna loads lower down the tower. The proper approach in this case is to have a qualified mechanical engineer check the configuration, to see if guy placement and strength is adequate for the additional antennas down the tower.

Mounting the mast and antenna as shown in Fig 31B increases tower loads in the region of the mast. You should investigate these loads to ensure that the tower bracing in that area is sufficient. Now we will consider the problem of bending the rotating mast.

### Mast Strength

When you mount antennas on a mast above the tower top, you should examine the bending loads on the mast to ensure that it will be strong enough. This section explains how to perform mast stress calculations for a single sustained wind speed. This procedure does not include height, exposure and

gust-response factors found in most tower design standards.

Here are some fundamental formulas and values used to calculate the bending stress in a mast mounted in the top of a tower. The basic formula for wind pressure is:

$$P = .00256 V^2 \quad (\text{Eq 1})$$

where

P is the wind pressure is in pounds per square foot (psf)

V = wind speed in miles per hour (mph)

This assumes an air density for standard temperature and atmospheric pressure at sea level. The wind speed is not the Basic Wind Speed discussed in other sections of this chapter. It is simply a steady state (static) wind velocity.

The formula for calculating the force created by the wind on a structure is:

$$F = P \times A \times C_d \quad (\text{Eq 2})$$

where

P = the wind pressure from Eq (1)

A = the flat projected area of the structure (square feet)

C<sub>d</sub> = drag coefficient for the shape of the structure's members.

The commonly accepted *drag coefficient* for long cylindrical members like the tubing used for the mast and antenna is 1.20. The coefficient for a flat plate is 2.0.

The formula used to find the *bending stress* in a simple beam like our mast is:

$$\sigma = \frac{M \times c}{I} \quad (\text{Eq 3})$$

where

σ = the stress in pounds per square inch (psi)

M = *bending moment* at the base of the mast (inch-pounds)

c = 1/2 of the mast outside diameter (inches)

I = *moment of inertia* of the mast section (inches<sup>4</sup>)

In this equation you must make sure that all values are in the same units. To arrive at the mast stress in pounds per square inch (psi), the other values need to be in inches and pounds also. The equation used to find the moment of inertia for the round tubing mast section is:

$$I = \frac{\pi}{4} (R^4 - r^4) \quad (\text{Eq 4})$$

where

I = Moment of Inertia of the section (inches<sup>4</sup>)

R = Radius of tube outside diameter (inches)

r = Radius of tube inside diameter (inches)

This value describes the distribution of material about the mast *centroid*, which determines how it behaves under load. The equation used to compute the *bending moment* at the base of the mast (where it is supported by the tower) is:

$$M = (F_M \times L_M) + (F_A \times L_M) \quad (\text{Eq 5})$$

where

- $F_M$  = wind force from the mast (pounds)
- $L_M$  = Distance from tower top to center of mast (inches)
- $F_A$  = Wind force from the antenna (pounds)
- $L_A$  = Distance from tower top to antenna attachment (inches)

$L_M$  is the distance to the center of the portion of the mast extending above the tower top. Additional antennas can be added to this formula by including their  $F \times L$ . In the installation shown in Fig 31B, a wind speed of 90 mph, and a mast that is 2 inches OD, with a 0.250-inch wall thickness, the steps for calculating the mast stress are:

1. Calculate the wind pressure for 90 mph, from Eq 1:

$$P = .00256 V^2 = .00256 \times (90)^2 = 20.736 \text{ psf}$$

2. Determine the flat projected area of the mast. The portion of the mast above the tower is 15 feet long and has an outside diameter of 2 inches, which is 2/12 feet.

$$\text{Mast FPA, } A_M = 15 \text{ feet} \times (2 \text{ inches} / 12 \text{ inches/feet}) = 2.50 \text{ square feet.}$$

3. Calculate the wind load on the mast, from Eq 2:

$$\text{Mast Force, } F_M = P \times A \times C_d = 20.736 \text{ psf} \times 2.50 \text{ feet}^2 \times 1.20 = 62.21 \text{ pounds}$$

4. Calculate the wind load on the antenna: From Eq (2)

$$\text{Antenna Force, } F_A = P \times A \times C_d = 20.736 \text{ psf} \times 14.94 \text{ feet}^2 \times 1.20 = 371.76 \text{ pounds}$$

5. Calculate the mast *Bending Moment*, from Eq 5:

$$M = (F_M \times L_M) + (F_A \times L_A) \\ = (62.21 \text{ pounds} \times 90 \text{ inches}) + (371.76 \text{ pounds} \times 84 \text{ inches}) = 36827 \text{ inch-pounds}$$

where  $L_M = 7.5 \text{ feet} \times 12 \text{ inches/foot} = 90 \text{ inches}$  and  $L_A = 7.0 \text{ feet} \times 12 \text{ inches/foot} = 84 \text{ inches}$ .

6. Calculate the mast *Moment of Inertia*, from Eq 4:

$$I = \frac{\pi}{4}(R^4 - r^4) = \frac{\pi}{4}(1.0^4 - 0.75^4) = 0.5369 \text{ inches}^4$$

where, for a 2.0-inch OD and 0.250-inch wall thickness tube,  $R = 1.0$  and  $r = 0.75$ .

7. Calculate the mast *Bending Stress*, from Eq 3:

$$\sigma = \frac{M \times c}{I} = \frac{36827 \text{ inch pounds} \times 1.0 \text{ inches}}{0.5369} \\ = 68592 \text{ psi}$$

If the yield strength of the mast material is greater than the calculated bending stress, the mast is considered safe for this configuration and wind speed. If the calculated stress is higher than the mast yield strength, a stronger alloy, or a larger mast, or one with a thicker wall is required.

There are many different materials and manufacturing processes for tubing that may be used for a mast. Yield strengths range from 25,000 psi to nearly 100,000 psi. Knowing the minimum yield strength of the material used

for a mast is an important part of determining if it will be safe. Using unknown materials renders efforts from the preceding calculations useless!

When evaluating a mast with multiple antennas attached to it, special care should be given to finding the worst-case condition (wind direction) for the system. What may appear to be the worst load case along a single azimuth exposure, by virtue of the combined flat projected antenna areas, may not always be the exposure that creates the largest mast bending moment. Masts with multiple stacked antennas should always be examined to find the exposure that produces the largest mast bending moment. The antenna flat projected areas at 0° and 90° azimuths are particularly useful for this evaluation.

## ANTENNA INSTALLATION

All antenna installations are different in some respects. Therefore, thorough planning is the most important first step in installing any antenna. Before anyone climbs the tower, the whole process should be discussed to be sure each crewmember understands what is to be done. And remember that the person on the tower is in charge! Coordinate beforehand what signals and commands are used: “Up” or “Up Slowly” for raising something from the ground; “Down” or “Down Slowly” for the opposite.

“Watch Out!” or “Watch Out Below!” works for dropped hardware or tools to alert the ground crew below. Remember, once someone is on the tower, no one should be allowed to stand near the base of the tower!

Consider what tools and parts must be assembled and what items must be taken up the tower, and plan alternative actions for possible trouble spots. Extra trips up and down the tower can be avoided by careful planning.

If done properly, the actual work of getting the antenna into position can be executed quite easily with only one person at the top of the tower. The ground crew should do all the heavy work and leave the person on the tower free to guide the antenna into position. Because the ground crew does all the lifting, a large pulley, preferably on a gin pole placed at the top of the tower, is essential. Local radio clubs often have gin poles available for use by their members. Stores that sell tower materials frequently rent gin poles as well.

A gin pole should be placed along the side of the tower so the pulley is no more than 2 feet above the top of the tower (or the point at which the antenna is to be placed). Normally this height is sufficient to allow the antenna to be positioned easily. An important reason that the pulley is placed at this level is that there can be considerable bending loads on the gin pole when the antenna is pulled away from the tower to maneuver past guy wires.

Sometimes the mast to which the antenna will be mounted is used as a place to hang the pulley. You should take care that you don’t end up bending the mast by placing the pulley too high on the mast. It may be necessary to back-guy the mast on the opposite side of the tower from which the antenna is raised.

The rope (halyard) through the pulley must be somewhat longer than twice the tower height so that the ground crew

can raise the antenna from ground level. The rope should be  $\frac{1}{2}$  or  $\frac{5}{8}$  inch diameter for both strength and ease of handling. Smaller diameter rope is less easily manipulated; it has a tendency to jump out of the pulley track and foul pulley operation.

The first person to climb the tower should carry an end of the halyard so that the gin pole can be lifted and secured to the tower. Those climbing the tower must have safety belts. Belts provide safety and convenience; it is simply impossible to work effectively while hanging onto the tower with one hand.

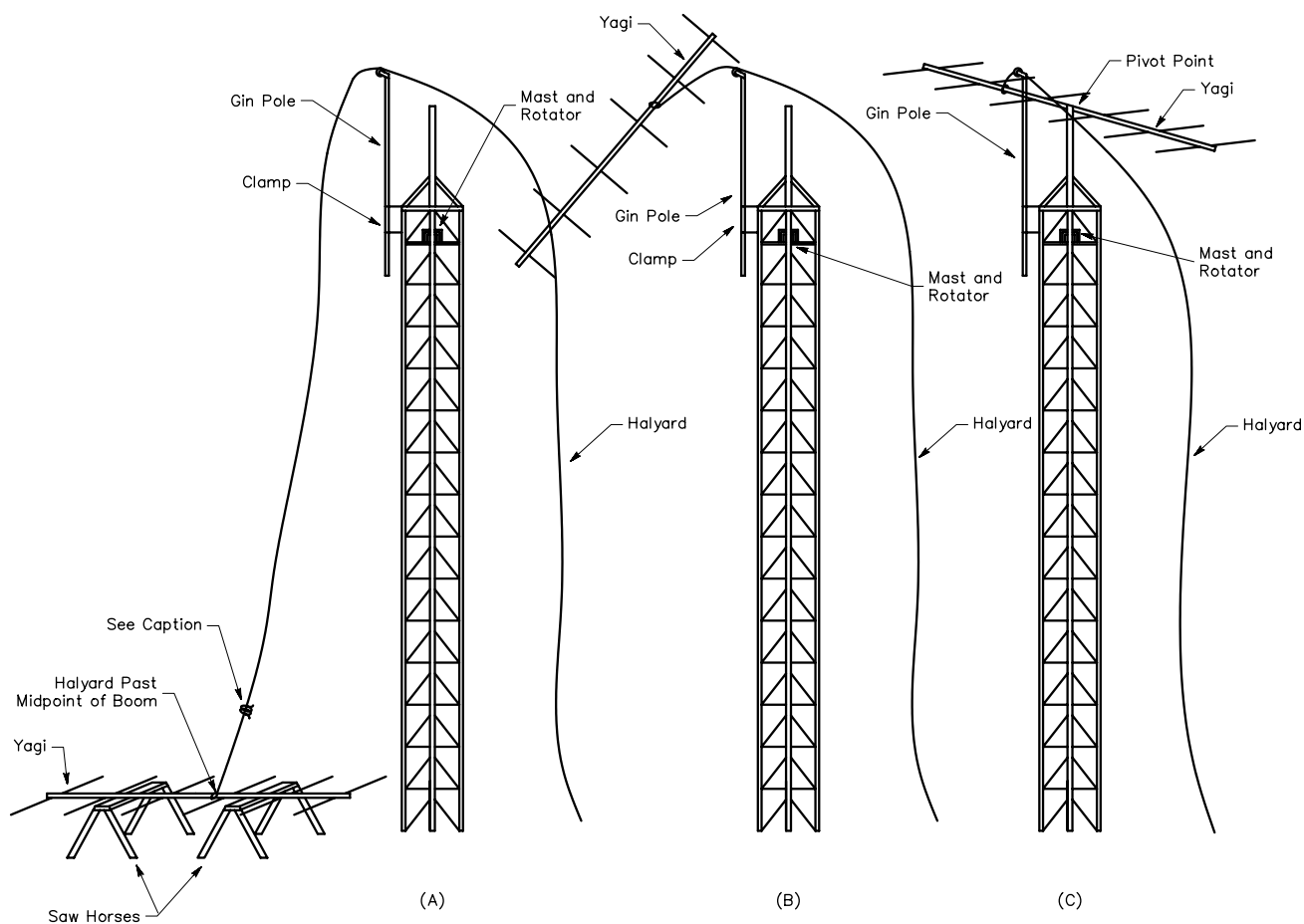
Once positioned, the gin pole and pulley allow parts and tools to be sent up the tower. A useful trick for sending up small items like bolts and pliers is for a ground crew

member to slide them through the rope strands where they are held by the rope for the trip to the top of the tower. Items that might be dislodged by contact with the tower should either be taped or tied to the halyard.

Ever present is the hazard of falling tools or hardware. It is foolish to stand near a tower when someone is working above. Ground crew members should wear hard-hats as extra insurance.

### Raising the Antenna Alongside the Tower

A technique that can save much effort in raising the antenna is outlined here. First, the halyard is passed through the gin-pole pulley or the pulley mounted to the mast, and the leading end of the rope is returned to the ground crew,



**Fig 32—Raising a Yagi antenna alongside the tower. At A the Yagi is placed in a clear area, with the boom pointing toward the tower. The halyard is passed under the elements, then is secured to the boom beyond the midpoint. B shows the antenna approaching the top of the mast. The person on the tower guides it after the lifting rope has been untied from the front of the antenna. At C the antenna is pulled into a horizontal position by the ground crew. The tower worker inserts the pivot bolt and secures it. Note: A short piece of rope is tied around the halyard and the boom at the front of the antenna to stabilize the beam as it is being raised. The tower worker removes it when the boom reaches him at the top of the tower.**

where it is tied to the antenna. The assembled antenna should be placed in a clear area of the yard (or the roof) so the boom points toward the tower. The halyard is then passed *under* the front elements of the beam to a position past the midpoint of the antenna, where it is securely tied to the boom (Fig 32A).

Note that once the antenna is installed, the tower worker must be able to reach and untie the halyard from the boom; the rope must be tied less than an arm's length along the boom from the mounting point. If necessary, a large loop may be placed around the first element located beyond the midpoint of the boom, with the knot tied near the center of the antenna. The rope may then be untied easily after completion of the installation. The halyard should be tied temporarily to the boom at the front of the antenna by means of a short piece of light rope or twine.

While the antenna is being raised, the ground crew does all the pulling. As soon as the front of the antenna reaches the top of the mast, the person atop the tower unties the light rope and prevents the front of the antenna from falling, as the ground crew continues to lift the antenna (Fig 32B). When the center of the antenna is even with the top of the tower, the tower worker puts one bolt through the mast and the antenna-mounting bracket on the boom. The single bolt acts as a pivot point and the ground crew continues to lift the back of the antenna with the halyard (Fig 32C). After the antenna is horizontal, the tower worker secures the rest of the mounting bolts and unties the halyard. By using this technique, the tower worker performs no heavy lifting.

### Avoiding Guy Wires

Although the same basic methods of installing a Yagi apply to any tower, guyed towers pose a special problem. Steps must be taken to avoid snagging the antenna on the guy wires. With proper precautions, however, even large antennas can be pulled to the top of a tower, even if the mast is guyed at several levels.

Sometimes one of the top guys can provide a *track* to support the antenna as it is pulled upward. Insulators in the guys, however, may obstruct the movement of the antenna. A better track made with rope is an alternative. One end of the rope is secured outside the guy anchors. The other end is passed over the top of the tower and back down to an anchor near the first anchor. So arranged, the rope forms a narrow V-track strung outside the guy wires. Once the V-track is secured, the antenna may simply be pulled up, resting on the track.

Another method is to tie a rope to the back of the antenna (but within reach of the center). The ground crews then pull the antenna out away from the guys as the antenna is raised. With this method, some crewmembers are pulling up the antenna to raise it while others are pulling down and out to keep the beam clear of the guys. Obviously, the opposing crews must act in coordination to avoid damaging the antenna. The beam is especially vulnerable when it begins to tip into the horizontal position. If the crew continues to pull out and down against the antenna, the boom can be broken. Another problem with this approach is that the

antenna may rotate on the axis of the boom as it is raised. To prevent such rotation, long lengths of twine may be tied to outer elements, one piece on each side of the boom. Ground personnel may then use these *tag lines* to stabilize the antenna. Where this is done, provisions must be made for untying the twine once the antenna is in place.

A third method is to tie the halyard to the center of the antenna. A crewmember, wearing a safety belt, walks the antenna up the tower as the crew on the ground raises it. Because the halyard is tied at the balance point, the tower worker can rotate the elements around the guys. A tag line can be tied to the bottom end of the boom so that a ground worker can help move the antenna around the guys. The tag line must be removed while the antenna is still vertical.

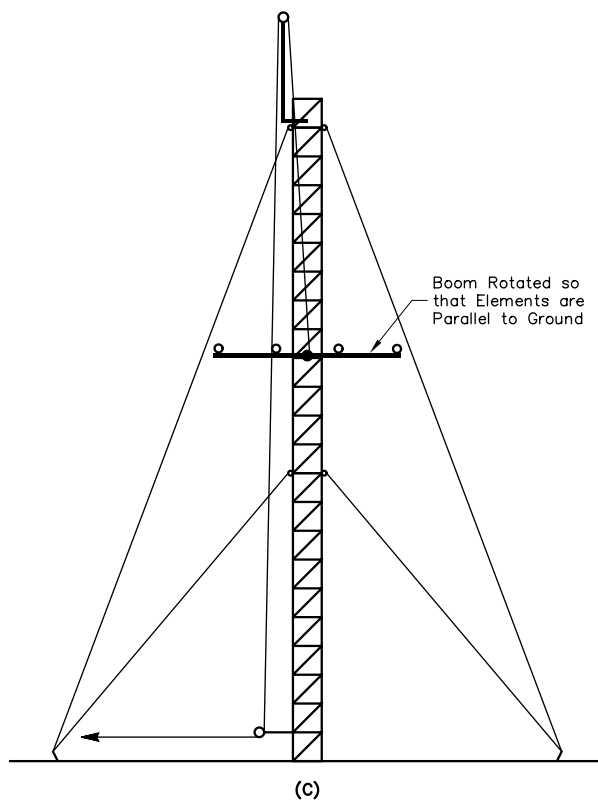
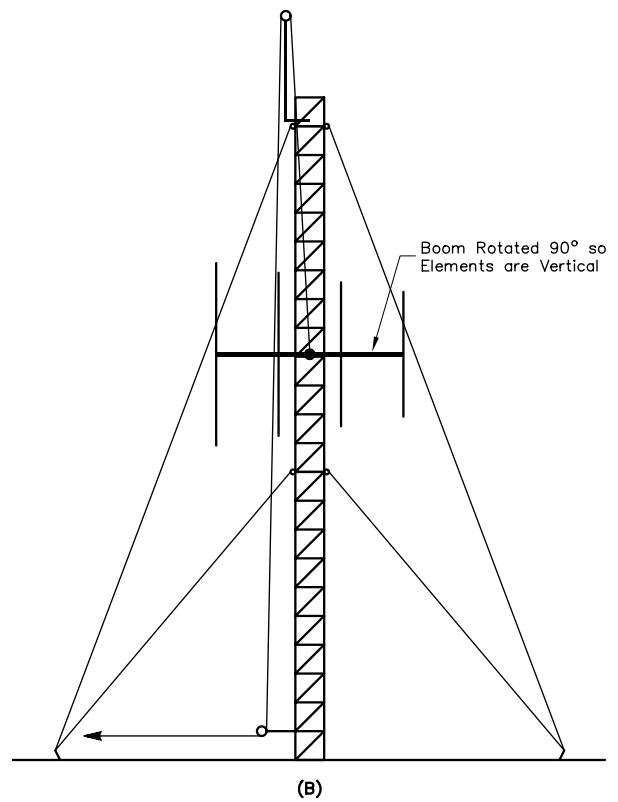
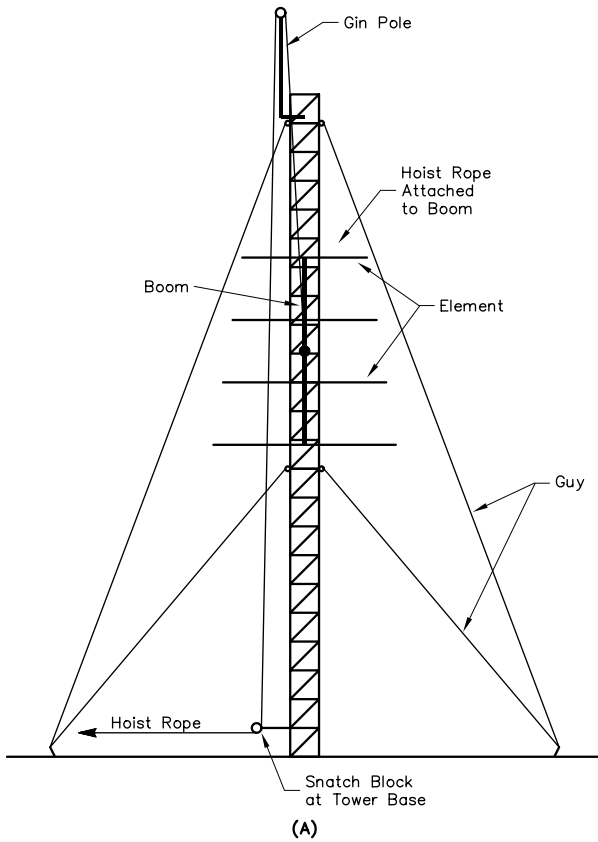
A fourth method is to build the antenna on the tower and then swing it into position. (See also the section below on the [PVRC Mount](#).) Building the Yagi on the tower works particularly well for Yagis mounted partway up the tower, as you might do in a stacked array. The technique works best when the vertical spacing between the guys is greater than the length of the Yagi boom.

[Fig 33](#) illustrates the steps involved. A pull rope through a gin-pole or tower-mounted pulley is secured to the boom at the final balance point and the ground crew raises the boom in a vertical position up the tower. A tie rope is used to temporarily secure the upper end of the boom to keep it stable while the boom is being raised. The tower person removes the tie-rope once the boom is raised to the right level and has been temporarily secured to the tower.

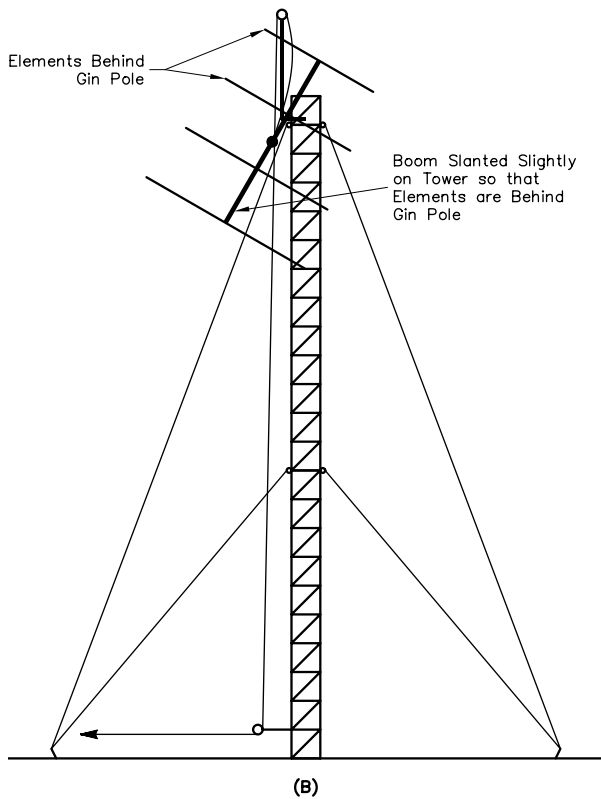
The elements are then brought up one at a time and mounted to the boom. It helps if you have a 2- or 3-foot long *spotting mast* temporarily attached to the boom to form a 90° frame of reference. This allows the ground crew to spot from below so that the elements are all lined up in the same plane. After all the elements are mounted and aligned properly, the temporary rope securing the boom to the tower is released, suspending the antenna on the pull rope. The tower person then rotates the boom 90° so that the elements are vertical. Next the elements are rotated 90° into the tower so that they are parallel to the ground. The ground crew then moves the boom up or down using the pull rope to the final point where it is mounted to the tower.

A modification of this technique also works for building a medium-sized Yagi on the top of the tower. This technique will work if the length of the gin pole at maximum safe extension is long enough. See [Fig 34](#).

As usual, the gin-pole pull rope is attached to the balance point of the boom and the boom is pulled up the tower in the vertical position, using a rope to temporarily tie the pull rope to the top end of the boom for stability. The boom is temporarily secured to the tower with rope in the vertical position so that the top end is just higher than the top of the tower. In order to clear the gin pole when the elements are mounted and the boom is raised higher to mount the next element, you must tilt the boom slightly so that the element mounted to the top end of the boom will be *behind*



**Fig 33—Building a Yagi partway down the tower. At A, the boom is lashed temporarily to the tower and elements are added, starting at the bottom. At B, the temporary rope securing the boom to the tower is removed and the boom is rotated 90° so that the elements are vertical. At C, the boom is rotated another 90°, “weaving through” guy wires if necessary, until the elements are parallel with the ground, whereupon the boom is secured to the tower.**



**Fig 34—Building a Yagi at the top of the tower. The length of the gin pole must be longer than  $\frac{1}{2}$  the boom so that the boom can be hoisted upwards to the place where it is mounted to the mast. Usually the boom is initially lashed to the tower slanted slightly from vertical so that the top element ends up *behind* the gin pole. The elements are mounted at the bottom end of the boom first to provide stability. Then the element at the top of the boom is mounted and the boom is moved upwards using the gin-pole hoist rope so that the next-to-top element may be mounted, again behind the gin pole. This process is repeated until all elements are mounted (save possibly the middle element if it can be reached easily from the tower once the beam has been mounted to the mast). Then the boom is tilted to the final position, weaving the elements to clear guy wires if necessary.**

the mast. This is very important!

The elements are first mounted to the bottom side of the boom to provide weight down below for stability. Then the top-most element is mounted to the boom. The tower person removes the temporary rope securing the boom to the tower and the ground crew uses the pull rope to move the mast vertically upwards to the point where the next element from the top can be mounted. Once all the elements are mounted and aligned in the same plane (with perhaps the center element closest to the mast-to-boom bracket left on the ground until later), the temporary securing rope is removed. The boom is now swung so that the elements can be maneuvered to clear the top guy wires. Once the elements are horizontal the boom is secured to the mast and the center

element is mounted.

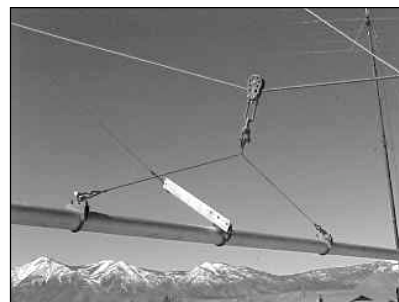
## Using a Tram

Another method to get a large Yagi to the top of the tower safely is a *tram*. A tram supports the antenna *under* the tram wire, using a pulley riding on the tram wire. The antenna can thus move more freely—without the friction it would have riding on top of a track rope, as described previously. This puts considerably less strain on the tram wire itself and on the mast to which it is tied on the tower. Some installers prefer to use a wire-rope tramline for its reduced sag.

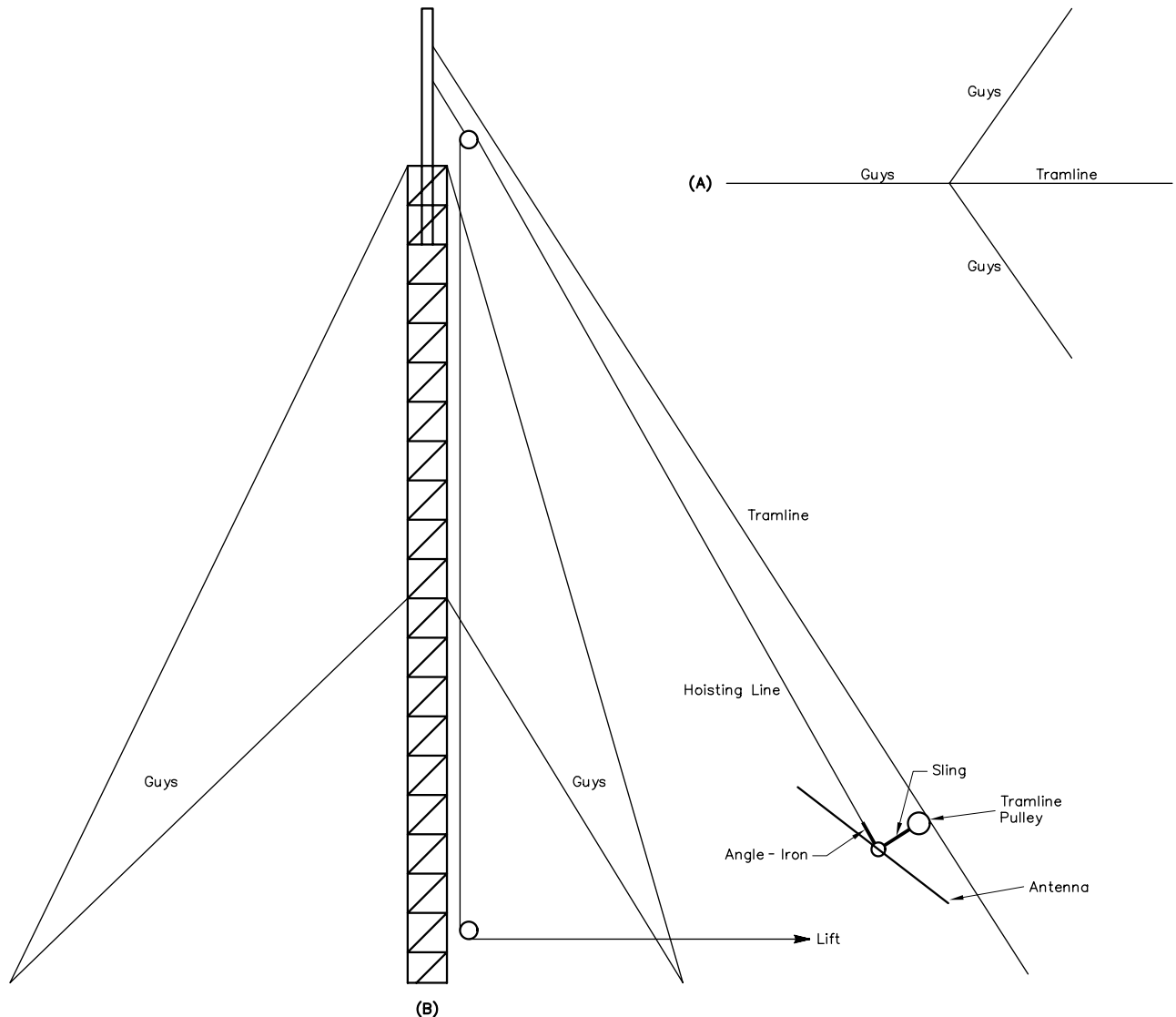
The tram method uses an easily constructed fixture mounted to the boom of the Yagi to stabilize it from rotating away from the desired attitude as the antenna is raised. A guy-wire cable or heavy rope is fixed to the mast about two feet above the point where the antenna will mount to the mast. A come-along is often used at the ground end to tension the tram wire properly. It is often necessary to back-guy the mast to make sure it doesn't get bent, since the horizontal forces acting on the mast can be considerable in any tram (or track) operation. (Note that the tram technique works well for side-mounted antennas also, where back-guying is not necessary if you are reasonably close to a guy set, as is usually the case.)

**Fig 35** is a photograph of a tram fixture built by Kurt Andress, K7NV. This consists of a pulley riding on top of the tramline. This pulley is attached using a caribiner or shackle to two equal-length wires connected to the boom to make an inverted-V shaped *sling*. The two slings are secured to the boom with modified muffler clamps containing eyebolts for the sling wires so that the antenna is perfectly balanced in the horizontal plane. Balance is very important to make sure the antenna rises properly on the tram without having the boom rotate downward on one end or the other.

The hoisting rope running through the tower-mounted pulley (and used by the ground crew to pull the antenna up to the tower on the tram line) is attached to a 2-foot piece of angle iron. This is attached to the boom with a muffler clamp. Note that the angle iron is rotated slightly from horizontal so that the plane of the elements is tilted upwards—this allows the elements to clear the guy wires as the antenna is raised. (While the antenna is close to the ground, the angle iron is adjusted so that the elements remain horizontal. Once



**Fig 35—Photo of the tram system used by Kurt Andress, K7NV. (Photo by K7NV)**



**Fig 36—At A, bird's-eye view of tram system used to bring large Yagi antennas from the ground to the top of the tower. At B, side view of rigging used for tramline and hoisting line, along with the sling and tram fixture used to hold the Yagi on the tramline.**

they are clear of the ground, the angle iron is readjusted to align the elements in the proper direction to clear the guy wires on the tower.) The force of the pull rope along the angle iron also stabilizes the antenna from yawing from side-to-side. Note in Fig 35 that the angle iron is mounted just off-center from where the boom-to-mast plate will be attached so that it clears the mast as the antenna nears the top of the tower. Fig 36 diagrams how the tram and hoisting line are rigged to the mast.

The tower person directs the activity of the ground crew below and guides the antenna to the mast. Once the end of the pull rope reaches the mast, the tower man ties the boom temporarily to the mast so that he can undo the pull rope from the tram-fixture angle iron and retie it around the boom.

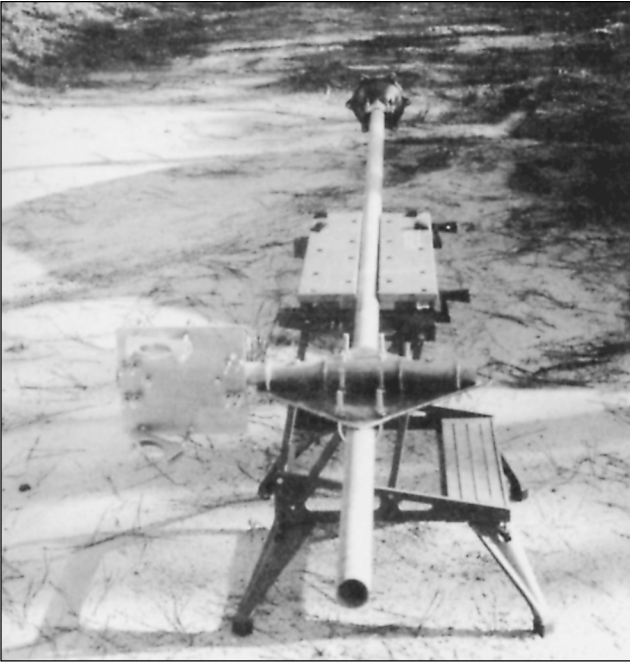
Then the antenna can be raised to the point where it can be mounted to the mast.

This technique has been employed to raise Yagis with booms as long as 42 feet at the N6RO contest station on towers as high as 130 feet. As with the track, the tram system requires a good deal of open real estate. While it sounds complicated to set up, you can raise some rather large antennas in less than an hour, once you get the hang of the operation.

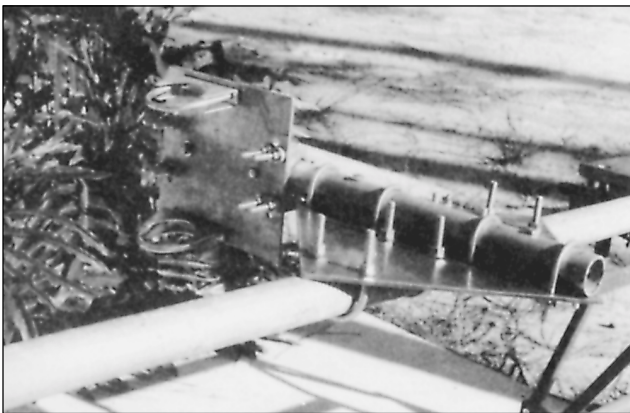
### THE PVRC MOUNT

The methods described above for hoisting antennas are sometimes not satisfactory for really large, heavy arrays. The best way to handle large Yagis is to assemble them on





**Fig 37—The PVRC mount, boom plate, mast and rotator ready to go. The mast and rotator are installed on the tower first.**



**Fig 38—Close-up of the PVRC mount. The long pipe (horizontal in this photo) is the rotating mast. The U bolts in the vertical plate at the left are ready to accept the antenna boom. The heads of two locking pins (bolts) are visible at the midline of the boom plate. The other two pins help secure the horizontal pipe to the large steel mast plate. (The head of the bolt nearest the camera blends in with the right hand leg of the U bolt behind it.)**

top of the tower. One way to do this easily is by using the *PVRC Mount*. Many members of the Potomac Valley Radio Club have successfully used this method to install large antennas. Simple and ingenious, the idea involves offsetting the boom from the mast to permit the boom to tilt 360° and rotate axially 360°. This permits the entire length of the boom to be brought alongside the tower, allowing the elements to be attached one by one. (It also allows any part of the antenna

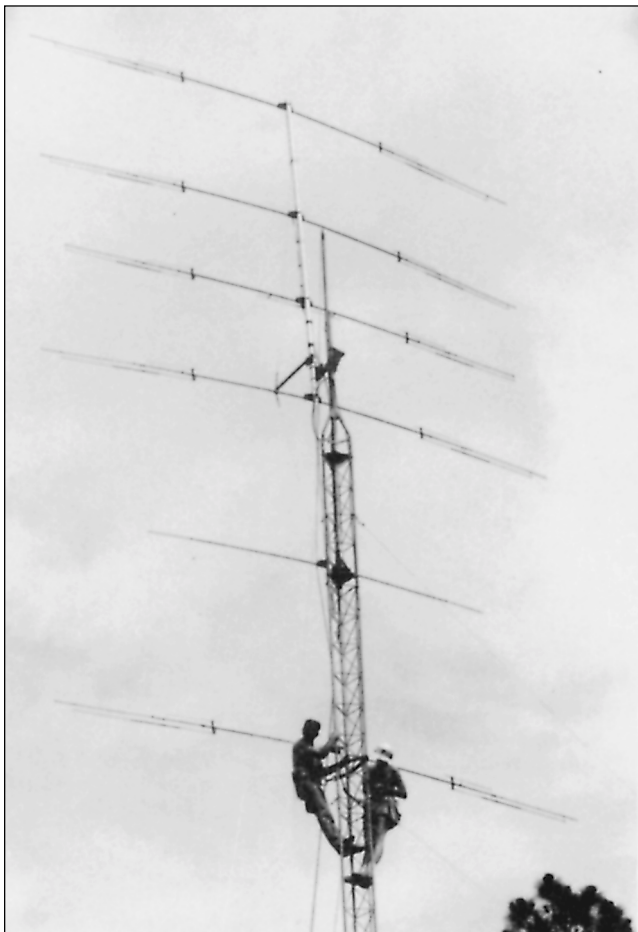


**Fig 39—Working at the 70-foot level. A gin pole makes pulling up and mounting the boom to the boom plate a safe and easy procedure.**

to be brought alongside the tower for antenna maintenance.)

See **Figs 37, 38, 39, 40** and **41**. The mount itself consists of a short length of pipe of the same diameter as the rotating mast (or greater), a steel plate, eight U bolts and four pinning bolts. The steel plate is the larger, horizontal one shown in Fig 37. Four U bolts attach the plate to the rotating mast, and four attach the horizontal pipe to the plate. The horizontal pipe provides the offset between the antenna boom and the tower. The antenna boom-to-mast plate is mounted at the outer end of the short pipe. Four bolts are used to ensure that the antenna ends up parallel to the ground, two pinning each plate to the short pipe. When the mast plate pinning bolts are removed and the four U bolts loosened, the short pipe and boom plate can be rotated through 360°, allowing either half of the boom to come alongside the tower.

First assemble the antenna on the ground. Carefully mark all critical dimensions, and then remove the antenna elements from the boom. Once the rotator and mast have been installed on the tower, a gin pole is used to bring the mast plate and short pipe to the top of the tower. There, the top crew unpins the horizontal pipe and tilts the antenna boom plate to place it in the vertical plane. The boom is attached to the boom plate at the balance point of the



**Fig 40—Mounting the last element prior to positioning the boom in a horizontal plane.**



**Fig 41—The U bolts securing the short pipe to the mast plate are loosened and the boom is turned to a horizontal position. This puts the elements in a vertical plane. Then the pipe U bolts are tightened and pinning bolts secured. The boom U bolts are then loosened and the boom turned axially 90°.**

assembled antenna. It is important that the boom be rotated axially so the bottom side of the boom is closest to the tower. This will allow the boom to be tilted without the elements striking the tower.

During installation it may be necessary to loosen one guy wire temporarily to allow for tilting of the boom. As a safety precaution, a temporary guy should be attached to the same leg of the tower just low enough so the assembled antenna will clear it.

The elements are assembled on the boom, starting with those closest to the center of the boom, working out alternately to the farthest director and reflector. This procedure must be followed. If all the elements are put first on one half of the boom, it will be dangerous (if not impossible) to put on the remaining elements. By starting at the middle and working outward, the balance point of the partly assembled antenna will never be so far removed from the tower that tilting of the boom becomes impossible.

When the last element is attached, the boom is brought parallel to the ground, the horizontal pipe is pinned to the mast plate, and the mast plate U bolts tightened. At this point, all the antenna elements will be positioned vertically. Next, loosen the U bolts that hold the boom and rotate the boom axially 90°, bringing the elements parallel to the ground. Tighten the boom bolts and double check all the hardware.

Many long-boom Yagis employ a truss to prevent boom sag. With the PVRC mount, the truss must be attached to a pipe that is independent of the rotating mast. A short length of pipe is attached to the boom as close as possible to the balance point. The truss then moves with the boom whenever the boom is tilted or twisted.

A precaution: Unless you have a really strong rotator, you should consider using this mount mainly for assembling the antenna on the tower. The offset between the boom and the mast with this assembly can generate high torque loads on the rotator. Mounting the boom as close as possible to the mast will minimize the torque when the antenna is pointed into the wind.

### THE TOWER ALTERNATIVE

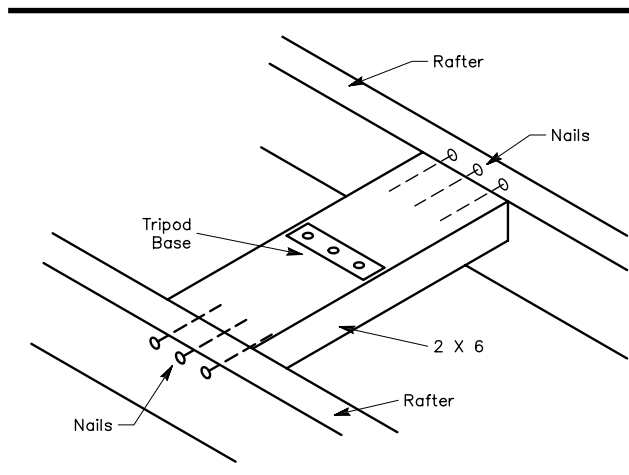
A cost saving alternative to the ground-mounted tower is the roof-mounted tripod. Units suitable for small HF or VHF antennas are commercially available. Perhaps the biggest problem with a tripod is determining how to fasten it securely to the roof.

One method of mounting a tripod on a roof is to nail 2 × 6 boards to the undersides of the rafters. Bolts can be extended from the leg mounts through the roof and the 2 × 6s. To avoid exerting too much pressure on the area of the roof between rafters, place another set of 2 × 6s on top of the roof (a mirror image of the ones in the attic). Installation details are shown in **Figs 42, 43, 44** and **45**.

The 2 × 6s are cut 4 inches longer than the outside distance between two rafters. Bolts are cut from a length of 1/4-inch-threaded rod. Nails are used to hold the boards in place during installation, and roofing tar is used to seal the



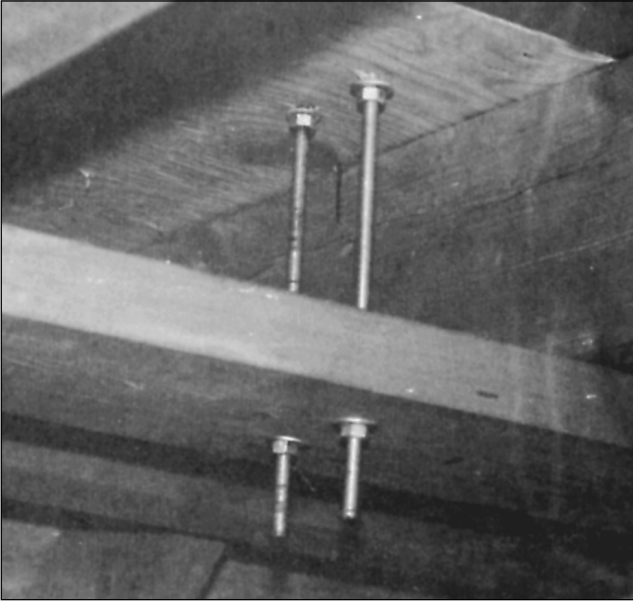
**Fig 42**—This tripod tower supports a rotary beam antenna. In addition to saving yard space, a roof-mounted tower can be more economical than a ground-mounted tower. A ground lead fastened to the lower part of the frame is for lightning protection. The rotator control cable and the coaxial line are dressed along two of the legs. (*Photo courtesy of Jane Wolfert*)



**Fig 43**—This cutaway view illustrates how the tripod tower is secured to the roof rafters. The leg to be secured to the crosspiece is placed on the outside of the roof. Another cross member is fastened to the underside of the rafters. Bolts, inserted through the roof and the two cross pieces, hold the inner cross member in place because of pressure applied. The inner crosspiece can be nailed to the rafter for added strength.



**Fig 44**—Three lengths of 2 × 6 wood mounted on the outside of the roof and reinforced under the roof by three identical lengths provide a durable means for anchoring the tripod. A thick coat of roofing tar guards against weathering and leaks.



**Fig 45—The strengthened anchoring for the tripod. Bolts are placed through two 2 × 6s on the underside of the roof and through the 2 × 6 on the top of the roof, as shown in Fig 43.**

area to prevent leaks.

Find a location on the roof that will allow the antenna to turn without obstruction from such things as trees, TV antennas and chimneys. Determine the rafter locations. (Chimneys and vent pipes make good reference points.) Now the tower is set in place atop three 2 × 6s. A plumb line run from the top center of the tower can be used to center it on the peak of the roof. Holes for the mounting bolts can now be drilled through the roof.

Before proceeding, the bottom of the 2 × 6s and the area of the roof under them should be given a coat of roofing tar. Leave about 1/8 inch of clear area around the holes to ensure easy passage of the bolts. Put the tower back in place and insert the bolts and tighten them. Apply tar to the bottom of the legs and the wooden supports, including the bolts. For added security the tripod can be guyed. Guys should be anchored to the frame of the house.

If a rotator is to be mounted above the tripod, pressure will be applied to the bearings. Wind load on the antenna will be translated into a “pinching” of one side of the bearings. Make sure that the rotator is capable of handling this additional stress.

### ROTATOR SYSTEMS

There are not that many choices when it comes to antenna rotators for the amateur antenna system. Making the correct decision as to how much capacity the rotator must have is very important to ensure trouble-free operation. Manufacturers generally provide an antenna surface-area rating to help the purchaser choose a suitable rotator. The maximum antenna area is linked to the rotator’s torque capability.

Some rotator manufacturers provide additional

information to help you select the right size of rotator for the antennas you plan to use. Hy-Gain provides an *Effective Moment* value. Yaesu calls theirs a *K-Factor*. Both of these ratings are torque values in foot-pounds. You can compute the effective moment of your antenna by multiplying the antenna turning radius by its weight. So long as the effective moment rating of the rotator is greater than or equal to the antenna value, the rotator can be expected to provide a useful service life.

There are basically four grades of rotators available to the amateur. The lightest-duty rotator is the type typically used to turn TV antennas. Without much difficulty, these rotators will handle a small 3-element tribander array (14, 21 and 28 MHz) or a single 21- or 28-MHz monoband three-element antenna. The important consideration with a TV rotator is that it lacks braking or holding capability. High winds turn the rotator motor via the gear train in a reverse fashion. Broken gears sometimes result.

The next grade up from the TV class of rotator usually includes a braking arrangement, whereby the antenna is held in place when power is not applied to the rotator. Generally speaking, the brake prevents gear damage on windy days. If adequate precautions are taken, this group of rotators is capable of holding and turning stacked monoband arrays, or up to a five-element 14-MHz system. The next step up in rotator strength is more expensive. This class of rotator will turn just about anything the most demanding amateur might want to install.

A description of antenna rotators would not be complete without the mention of the *prop pitch* class. The prop pitch rotator system consists of a surplus aircraft propeller blade pitch motor coupled to an indicator system and a power supply. There are mechanical problems of installation, however, resulting mostly from the size and weight of these motors. It has been said that a prop pitch rotator system, properly installed, is capable of turning a house. Perhaps in the same class as the prop pitch motor (but with somewhat less capability) is the electric motor of the type used for opening garage doors. These have been used successfully in turning large arrays.

Proper installation of the antenna rotator can provide many years of trouble-free service; sloppy installation can cause problems such as a burned out motor, slippage, binding and casting breakage. Most rotators are capable of accepting mast sizes of different diameters, and suitable precautions must be taken to shim an undersized mast to ensure dead-center rotation. It is very desirable to mount the rotator inside and as far below the top of the tower as possible. The mast absorbs the torsion developed by the antenna during high winds, as well as during starting and stopping.

Some amateurs have used a long mast from the top to the base of the tower. Rotator installation and service can be accomplished at ground level. A mast length of 10 feet or more between the rotator and the antenna will add greatly to the longevity of the entire system. Another benefit of mounting the rotator 10 feet or more below the antenna is that any misalignment among the rotator, mast and the top

of the tower is less significant. A tube at the top of the tower (a sleeve bearing) through which the mast protrudes almost completely eliminates any lateral forces on the rotator casing. All the rotator must do is support the downward weight of the antenna system and turn the array.

While the normal weight of the antenna and the mast is usually not more than a couple of hundred pounds, even with a large system, one can ease this strain on the rotator by installing a thrust bearing at the top of the tower. The bearing is then the component that holds the weight of the antenna system, and the rotator need perform only the rotating task.

### Indicator Alignment

A problem often encountered in amateur installations is that of misalignment between the direction indicator in the rotator control box and the heading of the antenna. With a light duty rotator, this happens frequently when the wind blows the antenna to a different heading. With no brake, the force of the wind can move the gear train and motor of the rotator, while the indicator remains fixed. Such rotator systems have a mechanical stop to prevent continuous rotation during operation, and provision is usually included to realign the indicator against the mechanical stop from inside the shack. During installation, the antenna must be oriented correctly for the mechanical stop position, which is usually north.

In larger rotator systems with an adequate brake, indicator misalignment is caused by mechanical slippage in the antenna boom-to-mast hardware. Many texts suggest that the boom be pinned to the mast with a heavy-duty bolt and the rotator be similarly pinned to the mast. There is a trade-off here. If there is sufficient wind to cause slippage in the couplings without pins, with pins the wind could break a rotator casting. The slippage will act as a clutch release, which may prevent serious damage to the rotator. On the other hand, the amateur might not like to climb the tower and realign the system after each heavy windstorm.

### BIBLIOGRAPHY

Source material and more extended discussions of the

topics covered in this chapter can be found in the references listed below and in the texts listed at the end of [Chapter 2](#).

- L. H. Abraham, "Guys for Guys Who Have To Guy," *QST*, Jun 1955.
- K. Baker, "A Ladder Mast," *QST*, Jun 1981, p 24.
- W. R. Gary, "Toward Safer Antenna Installations," *QST*, Jan 1980, p 56.
- S. F. Hoerner, "Fluid Dynamic Drag," published by author, Bricktown, New Jersey, 1965, pp 1-10.
- C. L. Hutchinson, "A Tree-Mounted 30-Meter Ground-Plane Antenna," *QST*, Sep 1984, pp 16-18.
- M. P. Keown and L. L. Lamb, "A Simple Technique for Tower-Section Separation," *QST*, Sep 1979, pp 37-38.
- P. O'Dell, "The Ups and Downs of Towers," *QST*, Jul 1981, p 35.
- S. Phillabaum, "Installation Techniques for Medium and Large Yagis," *QST*, Jun 1979, p 23.
- C. J. Richards, "Mechanical Engineering in Radar and Communications" (London: Van Nostrand Reinhold Co., 1969) pp 162-165.
- D. Weber "Determination of Yagi Wind Loads Using the Cross-Flow Principle," *Communications Quarterly*, Spring 1993.
- A. B. White, "A Delayed Brake Release for the Ham-II," *QST*, Aug 1977, p 14.
- B. White, E. White and J. White, "Assembling Big Antennas on Fixed Towers," *QST*, Mar 1982, pp 28-29
- L. Wolfert, "The Tower Alternative," *QST*, Nov 1980, p 36.
- W. C. Young., "Roark's Formulas for Stress & Strain" (New York: McGraw-Hill Co., 1989), pp 67, 96
- Structural Standards for Steel Antenna Towers and Antenna Supporting Structures*, TIA/EIA Standard TIA/EIA-222-F, Electronic Industries Association, Mar 1996. May be purchased from Telecommunications Industry Association (TIA), Standards and Technology Department, 2500 Wilson Boulevard, Arlington VA, 22201 or Global Engineering Documents, 15 Inverness Way East, Englewood, CO 80112-5704, 1-800-854-7179.

# Chapter 23

# Radio Wave Propagation

Because radio communication is carried on by means of electromagnetic waves traveling through the Earth's atmosphere, it is important to understand the nature of these waves and their behavior in the propagation medium. Most antennas will radiate the power applied to them efficiently, but no antenna can do all things equally well, under all circumstances. Whether you design and build your own antennas, or buy them and have them put up by a professional,

you'll need propagation know-how for best results, both during the planning stages and while operating your station.

For station planning, this chapter contains detailed information on elevation angles from transmitting locations throughout the world to important areas throughout the world. With this information in hand, you can design your own antenna installation for optimum capabilities possible within your budget. See the [CD-ROM](#) at the back of this book.

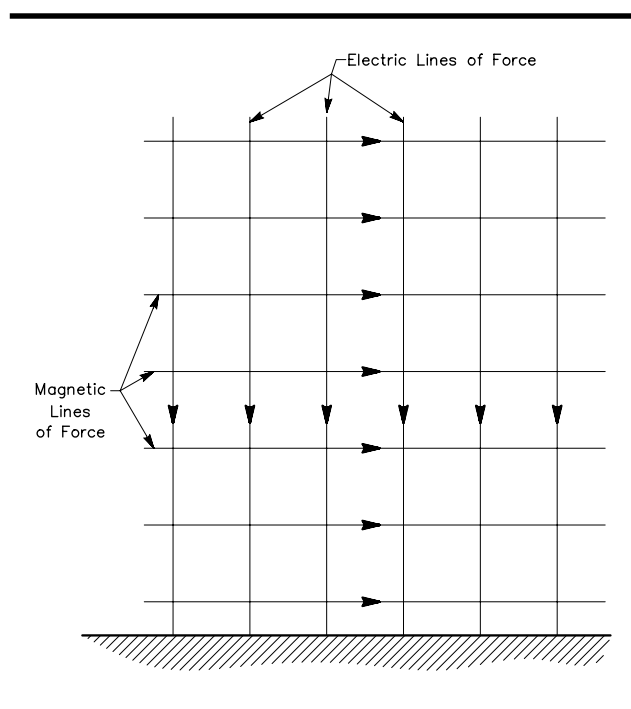
## The Nature of Radio Waves

You probably have some familiarity with the concept of electric and magnetic fields. A radio wave is a combination of both, with the energy divided equally between them. If the wave could originate at a point source in free space, it would spread out in an ever-growing sphere, with the source at the center. No antenna can be designed to do this, but the theoretical *isotropic antenna* is useful in explaining and measuring the performance of practical antennas we *can* build. It is, in fact, the basis for any discussion or evaluation of antenna performance.

Our theoretical spheres of radiated energy would expand very rapidly at the same speed as the propagation of light, approximately 186,000 miles or 300,000,000 meters per second. These values are close enough for practical purposes, and are used elsewhere in this book. If one wishes to be more precise, light propagates in a vacuum at the speed of 299.7925 meters per microsecond, and slightly slower in air.

The path of a *ray* traced from its source to any point on a spherical surface is considered to be a straight line—a radius of the sphere. An observer on the surface of the sphere would think of it as being flat, just as the Earth seems flat to us. A radio wave far enough from its source to appear flat is called a *plane wave*. From here on, we will be discussing primarily plane waves.

It helps to understand the radiation of electromagnetic energy if we visualize a plane wave as being made up of electric and magnetic forces, as shown in **Fig 1**. The nature of wave propagation is such that the electric and magnetic lines of force are always perpendicular. The plane containing the sets of crossed lines represents the wave front. The



**Fig 1—Representation of the magnetic and electric fields of a vertically polarized plane wave traveling along the ground. The arrows indicate instantaneous directions of the fields for a wave traveling perpendicularly out of the page toward the reader. Reversal of the direction of one set of lines reverses the direction of travel. There is no change in direction when both sets are reversed. Such a dual reversal occurs in fact once each half cycle.**

direction of travel is always perpendicular to the wave front; “forward” or “backward” is determined by the relative directions of the electric and magnetic forces.

The speed of travel of a wave through anything but a vacuum is always less than 300,000,000 meters per second. How much less depends on the medium. If it is air, the reduction in propagation speed can be ignored in most discussions of propagation at frequencies below 30 MHz. In the VHF range and higher, temperature and moisture content of the medium have increasing effects on the communication range, as will be discussed later. In solid insulating materials the speed is considerably less. In distilled water (a good insulator) the speed is  $1/9$  that in free space. In good conductors the speed is so low that the opposing fields set up by the wave front occupy practically the same space as the wave itself, and thus cancel it out. This is the reason for “skin effect” in conductors at high frequencies, making metal enclosures good shields for electrical circuits working at radio frequencies.

### Phase and Wavelength

Because the velocity of wave propagation is so great, we tend to ignore it. Only  $1/7$  of a second is needed for a radio wave to travel around the world—but in working with antennas the *time* factor is extremely important. The wave concept evolved because an alternating current flowing in a wire (antenna) sets up moving electric and magnetic fields. We can hardly discuss antenna theory or performance at all without involving travel time, consciously or otherwise.

Waves used in radio communication may have frequencies from about 10,000 to several billion Hz. Suppose the frequency is 30 MHz. One cycle, or period, is completed in  $1/30,000,000$  second. The wave is traveling at 300,000,000 meters per second, so it will move only 10 meters during the time that the current is going through one complete period of alternation. The electromagnetic field 10 meters away from the antenna is caused by the current that was flowing one period earlier in time. The field 20 meters away is caused by the current that was flowing two periods earlier, and so on.

If each period of the current is simply a repetition of the one before it, the currents at corresponding instants in each period will be identical. The fields caused by those currents will also be identical. As the fields move outward from the antenna they become more thinly spread over larger and larger surfaces. Their amplitudes decrease with distance from the antenna but they do not lose their identity with respect to the instant of the period at which they were generated. They are, and they remain, *in phase*. In the example above, at intervals of 10 meters measured outward from the antenna, the phase of the waves at any given instant is identical.

From this information we can define both “wave front” and “wavelength.” Consider the wave front as an imaginary surface. On every part of this surface, the wave is in the same phase. The wavelength is the distance between two wave fronts having the same phase at any given instant. This

distance must be measured perpendicular to the wave fronts along the line that represents the direction of travel. The abbreviation for wavelength is the Greek letter lambda,  $\lambda$ , which is used throughout this book.

The wavelength will be in the same length units as the velocity when the frequency is expressed in the same time units as the velocity. For waves traveling in free space (and near enough for waves traveling through air) the wavelength is

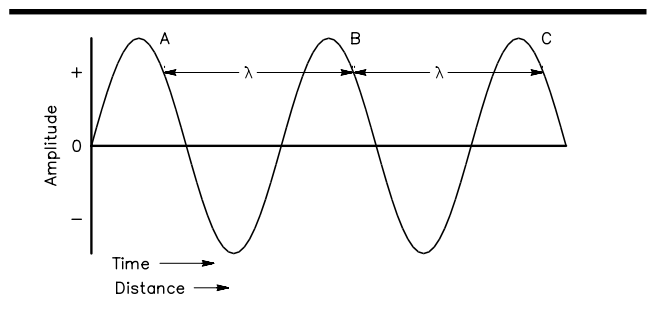
$$\lambda_{\text{meters}} = \frac{299.7925}{F(\text{MHz})} \quad (\text{Eq 1})$$

There will be few pages in this book where phase, wavelength and frequency do not come into the discussion. It is essential to have a clear understanding of their meaning in order to understand the design, installation, adjustment or use of antennas, matching systems or transmission lines in detail. In essence, “phase” means “time.” When something goes through periodic variations, as an alternating current does, corresponding instants in succeeding periods are *in phase*.

The points A, B and C in **Fig 2** are all in phase. They are corresponding instants in the current flow, at  $1-\lambda$  intervals. This is a conventional view of a sine-wave alternating current, with time progressing to the right. It also represents a “snapshot” of the intensity of the traveling fields, if distance is substituted for time in the horizontal axis. The distance between A and B or between B and C is one wavelength. The field-intensity distribution follows the sine curve, in both amplitude and polarity, corresponding exactly to the time variations in the current that produced the fields. Remember that this is an *instantaneous* picture—the wave moves outward, much as a wave created by a rock thrown into water does.

### Polarization

A wave like that in **Fig 1** is said to be *polarized* in the direction of the electric lines of force. The polarization here is vertical, because the electric lines are perpendicular to the surface of the Earth. It is one of the laws of electromagnetics



**Fig 2**—The instantaneous amplitude of both fields (electric and magnetic) varies sinusoidally with time as shown in this graph. Since the fields travel at constant velocity, the graph also represents the instantaneous distribution of field intensity along the wave path. The distance between two points of equal phase such as A-B and B-C is the length of the wave.

that electric lines touching the surface of a perfect conductor must do so perpendicularly, or else they would have to generate infinite currents in the conductor, an obvious impossibility. Most ground is a rather good conductor at frequencies below about 10 MHz, so waves at these frequencies, traveling close to good ground, are mainly vertically polarized. Over partially conducting ground there may be a forward tilt to the wave front; the tilt in the electric lines of force increases as the energy loss in the ground becomes greater.

Waves traveling in contact with the surface of the Earth, called *surface waves*, are of little practical use in amateur communication. This is because as the frequency is raised, the distance over which they will travel without excessive energy loss becomes smaller and smaller. The surface wave is most useful at low frequencies and through the standard AM broadcast band. The surface wave will be covered later. At high frequencies a wave reaching a receiving antenna has had little contact with the ground, and its polarization is not necessarily vertical.

If the electric lines of force are horizontal, the wave is said to be *horizontally polarized*. Horizontally and vertically polarized waves may be classified generally under *linear polarization*. Linear polarization can be anything between horizontal and vertical. In free space, “horizontal” and “vertical” have no meaning, since the reference of the seemingly horizontal surface of the Earth has been lost.

In many cases the polarization of waves is not fixed, but rotates continually, somewhat at random. When this occurs the wave is said to be *elliptically polarized*. A gradual shift in polarization in a medium is known as *Faraday rotation*. For space communication, circular polarization is commonly used to overcome the effects of Faraday rotation. A circularly polarized wave rotates its polarization through 360° as it travels a distance of one wavelength in the propagation medium. The direction of rotation as viewed from the transmitting antenna defines the direction of circularity—right-hand (clockwise) or left-hand (counterclockwise). Linear and circular polarization may be considered as special cases of elliptical polarization.

### Field Intensity

The energy from a propagated wave decreases with distance from the source. This decrease in strength is caused by the spreading of the wave energy over ever-larger spheres as the distance from the source increases.

A measurement of the strength of the wave at a distance from the transmitting antenna is its *field intensity*, which is synonymous with *field strength*. The strength of a wave is measured as the voltage between two points lying on an electric line of force in the plane of the wave front. The standard of measure for field intensity is the voltage developed in a wire that is 1 meter long, expressed as volts per meter. (If the wire were 2 meters long, the voltage developed would be divided by two to determine the field strength in volts per meter.)

The voltage in a wave is usually low, so the measurement is made in millivolts or microvolts per meter. The voltage goes through time variations like those of the current that caused the wave. It is measured like any other ac voltage—in terms of the effective value or, sometimes, the peak value. It is fortunate that in amateur work it is not necessary to measure actual field strength, as the equipment required is elaborate. We need to know only if an adjustment has been beneficial, so relative measurements are satisfactory. These can be made easily with home-built equipment.

### Wave Attenuation

In free space, the field intensity of the wave varies inversely with the distance from the source, once you are in the radiating far field of the antenna. If the field strength at 1 mile from the source is 100 millivolts per meter, it will be 50 millivolts per meter at 2 miles, and so on. The relationship between field intensity and power density is similar to that for voltage and power in ordinary circuits. They are related by the impedance of free space, which is approximately 377 Ω. A field intensity of 1 volt per meter is therefore equivalent to a power density of

$$P = \frac{E^2}{Z} = \frac{1(\text{volt/m})^2}{377 \Omega} = 2.65 \text{ mW/m}^2 \quad (\text{Eq 2})$$

Because of the relationship between voltage and power, the power density therefore varies with the square root of the field intensity, or inversely with the *square* of the distance. If the power density at 1 mile is 4 mW per square meter, then at a distance of 2 miles it will be 1 mW per square meter.

It is important to remember this *spreading loss* when antenna performance is being considered. Gain can come only from narrowing the radiation pattern of an antenna, to concentrate the radiated energy in the desired direction. There is no “antenna magic” by which the total energy radiated can be increased.

In practice, attenuation of the wave energy may be much greater than the “inverse-distance” law would indicate. The wave does not travel in a vacuum, and the receiving antenna seldom is situated so there is a clear line of sight. The Earth is spherical and the waves do not penetrate its surface appreciably, so communication beyond visual distances must be by some means that will bend the waves around the curvature of the Earth. These means involve additional energy losses that increase the path attenuation with distance, above that for the theoretical spreading loss in a vacuum.

### Bending of Radio Waves

Radio waves and light waves are both propagated as electromagnetic energy. Their major difference is in wavelength, though radio-reflecting surfaces are usually much smaller in terms of wavelength than those for light. In material of a given electrical conductivity, long waves penetrate deeper than short ones, and so require a thicker



mass for good reflection. Thin metal, however, is a good reflector of even long-wavelength radio waves. With poorer conductors, such as the Earth's crust, long waves may penetrate quite a few feet below the surface.

*Reflection* occurs at any boundary between materials of differing dielectric constant. Familiar examples with light are reflections from water surfaces and window panes. Both water and glass are transparent for light, but their dielectric constants are very different from that of air. Light waves, being very short, seem to “bounce off” both surfaces. Radio waves, being much longer, are practically unaffected by glass, but their behavior upon encountering water may vary, depending on the purity of that medium. Distilled water is a good insulator; salt water is a relatively good conductor.

Depending on their wavelength (and thus their frequency), radio waves may be reflected by buildings, trees, vehicles, the ground, water, ionized layers in the upper atmosphere, or at boundaries between air masses having different temperatures and moisture content. Ionospheric and atmospheric conditions are important in practically all communication beyond purely local ranges.

*Refraction* is the bending of a ray as it passes from one medium to another at an angle. The appearance of bending of a straight stick, where it enters water at an angle, is an example of light refraction known to us all. The degree of

bending of radio waves at boundaries between air masses increases with the radio frequency. There is slight atmospheric bending in our HF bands. It becomes noticeable at 28 MHz, more so at 50 MHz, and it is much more of a factor in the higher VHF range and in UHF and microwave propagation.

*Diffraction* of light over a solid wall prevents total darkness on the far side from the light source. This is caused largely by the spreading of waves around the top of the wall, due to the interference of one part of the beam with another. The dielectric constant of the surface of the obstruction may affect what happens to our radio waves when they encounter terrestrial obstructions—but the radio “shadow area” is never totally “dark.”

The three terms, reflection, refraction and diffraction, were in use long before the radio age began. Radio propagation is nearly always a mix of these phenomena, and it may not be easy to identify or separate them while they are happening when we are on the air. This book tends to rely on the words *bending* and *scattering* in its discussions, with appropriate modifiers as needed. The important thing to remember is that any alteration of the path taken by energy as it is radiated from an antenna is almost certain to affect on-the-air results—which is why this chapter on propagation is included in an antenna book.

## The Ground Wave

As we have already seen, radio waves are affected in many ways by the media through which they travel. This has led to some confusion of terms in earlier literature concerning wave propagation. Waves travel close to the ground in several ways, some of which involve relatively little contact with the ground itself. The term *ground wave* has had several meanings in antenna literature, but it has come to be applied to any wave that stays close to the Earth, reaching the receiving point without leaving the Earth's lower atmosphere. This distinguishes the ground wave from a *sky wave*, which utilizes the ionosphere for propagation between the transmitting and receiving antennas.

The ground wave could be traveling in actual contact with the ground, as in [Fig 1](#), where it is called the *surface wave*. Or it could travel directly between the transmitting and receiving antennas, when they are high enough so they can “see” each other—this is commonly called the *direct wave*. The ground wave also travels between the transmitting and receiving antennas by reflections or diffractions off intervening terrain between them. The ground-influenced wave may interact with the direct wave to create a vector-summed resultant at the receiver antenna.

In the generic term ground wave, we also will include ones that are made to follow the Earth's curvature by bending in the Earth's lower atmosphere, or *troposphere*, usually no more than a few miles above the ground. Often called

*tropospheric bending*, this propagation mode is a major factor in amateur communications above 50 MHz.

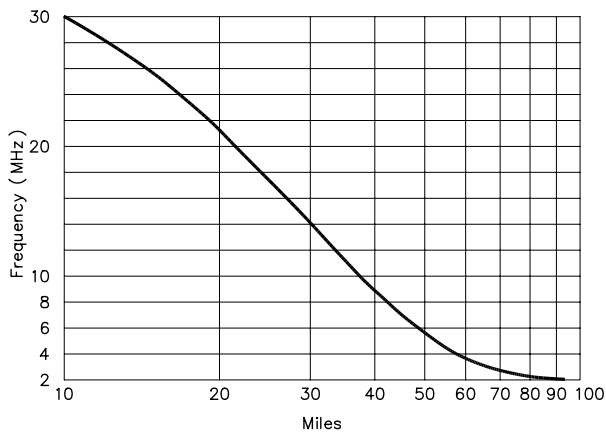
### THE SURFACE WAVE

The surface wave travels in contact with the Earth's surface. It can provide coverage up to about 100 miles in the standard AM broadcast band during the daytime, but attenuation is high. As can be seen from [Fig 3](#), the attenuation increases with frequency. The surface wave is of little value in amateur communication, except possibly at 1.8 MHz. Vertically polarized antennas must be used, which tends to limit amateur surface-wave communication to where large vertical systems can be erected.

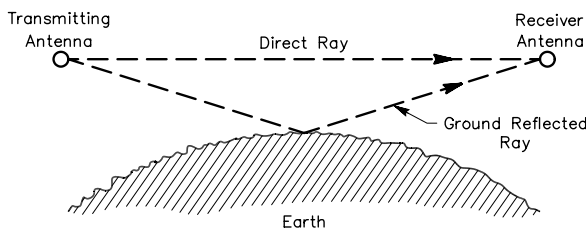
### THE SPACE WAVE

Propagation between two antennas situated within line of sight of each other is shown in [Fig 4](#). Energy traveling directly between the antennas is attenuated to about the same degree as in free space. Unless the antennas are very high or quite close together, an appreciable portion of the energy is reflected from the ground. This reflected wave combines with direct radiation to affect the actual signal received.

In most communication between two stations on the ground, the angle at which the wave strikes the ground will be small. For a horizontally polarized signal, such a reflection reverses the phase of the wave. If the distances traveled by



**Fig 3—Typical HF ground-wave range as a function of frequency.**



**Fig 4—The ray traveling directly from the transmitting antenna to the receiving antenna combines with a ray reflected from the ground to form the space wave. For a horizontally polarized signal a reflection as shown here reverses the phase of the ground-reflected ray.**

both parts of the wave were the same, the two parts would arrive out of phase, and would therefore cancel each other. The ground-reflected ray in Fig 4 must travel a little further, so the phase difference between the two depends on the lengths of the paths, measured in wavelengths. The wavelength in use is important in determining the useful signal strength in this type of communication.

If the difference in path length is 3 meters, the phase difference with 160-meter waves would be only  $360^\circ \times 3/160 = 6.8^\circ$ . This is a negligible difference from the  $180^\circ$  shift caused by the reflection, so the effective signal strength over the path would still be very small because of cancellation of the two waves. But with 6-meter radio waves the phase length would be  $360^\circ \times 3/6 = 180^\circ$ . With the additional  $180^\circ$  shift on reflection, the two rays would add. Thus, the space wave is a negligible factor at low frequencies, but it can be increasingly useful as the frequency is raised. It is a dominant factor in local amateur communication at 50 MHz and higher.

Interaction between the direct and reflected waves is the principle cause of “mobile flutter” observed in local VHF communication between fixed and mobile stations. The flutter effect decreases once the stations are separated enough

so that the reflected ray becomes inconsequential. The reflected energy can also confuse the results of field-strength measurements during tests on VHF antennas.

As with most propagation explanations, the space-wave picture presented here is simplified, and practical considerations dictate modifications. There is always some energy loss when the wave is reflected from the ground. Further, the phase of the ground-reflected wave is not shifted exactly  $180^\circ$ , so the waves never cancel completely. At UHF, ground-reflection losses can be greatly reduced or eliminated by using highly directive antennas. By confining the antenna pattern to something approaching a flashlight beam, nearly all the energy is in the direct wave. The resulting energy loss is low enough that microwave relays, for example, can operate with moderate power levels over hundreds or even thousands of miles. Thus we see that, while the space wave is inconsequential below about 20 MHz, it can be a prime asset in the VHF realm and higher.

### VHF Propagation Beyond Line of Sight

From Fig 4 it appears that use of the space wave depends on direct line of sight between the antennas of the communicating stations. This is not literally true, although that belief was common in the early days of amateur communication on frequencies above 30 MHz. When equipment became available that operated efficiently and after antenna techniques were improved, it soon became clear that VHF waves were actually being bent or scattered in several ways, permitting reliable communication beyond visual distances between the two stations. This was found true even with low power and simple antennas. The average communication range can be approximated by assuming the waves travel in straight lines, but with the Earth’s radius increased by one-third. The distance to the “radio horizon” is then given as

$$D_{\text{miles}} = 1.415 \sqrt{H_{\text{feet}}} \quad (\text{Eq 3})$$

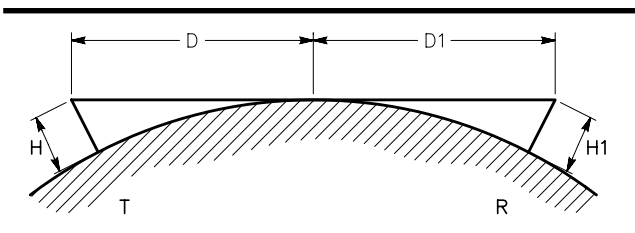
or

$$D_{\text{km}} = 4.124 \sqrt{H_{\text{meters}}} \quad (\text{Eq 4})$$

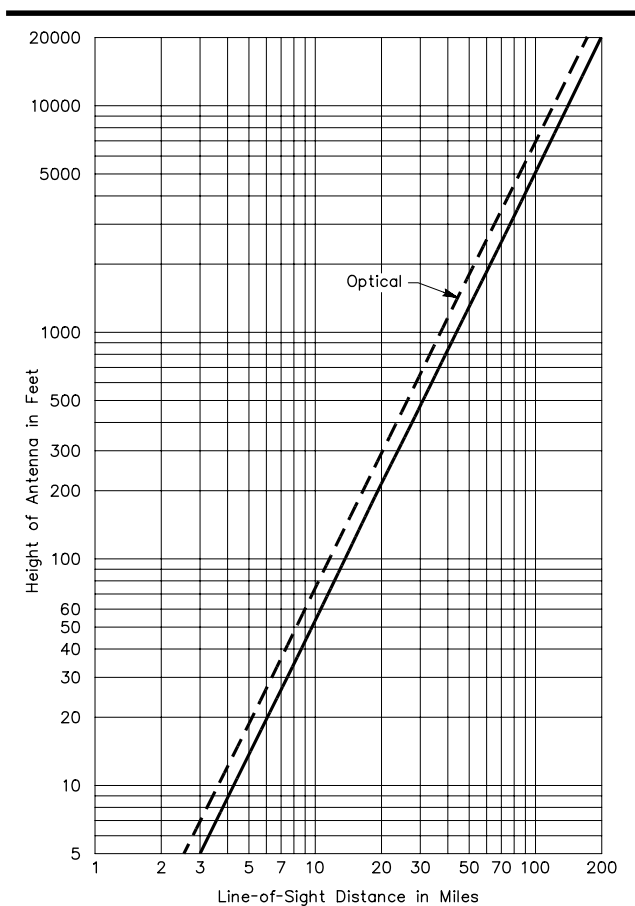
where H is the height of the transmitting antenna, as shown in Fig 5. The formula assumes that the Earth is smooth out to the horizon, so any obstructions along the path must be taken into consideration. For an elevated receiving antenna the communication distance is equal to  $D + D_1$ , that is, the sum of the distances to the horizon of both antennas. Radio horizon distances are given in graphic form in Fig 6. Two stations on a flat plain, one with its antenna 60 feet above ground and the other 40 feet, could be up to about 20 miles apart for strong-signal line-of-sight communication (11 + 9 mi). The terrain is almost never completely flat, and variations along the way may add to or subtract from the distance for reliable communication. Remember that energy is absorbed, reflected or scattered in many ways in nearly all communication situations. The formula or the chart will be a good guide for estimating the potential radius of

coverage for a VHF FM repeater, assuming the users are mobile or portable with simple, omnidirectional antennas. Coverage with optimum home-station equipment, high-gain directional arrays, and SSB or CW is quite a different matter. A much more detailed method for estimating coverage on frequencies above 50 MHz is given later in this chapter.

For maximum use of the ordinary space wave it is important to have the antenna as high as possible above



**Fig 5—**The distance  $D$  to the horizon from an antenna of height  $H$  is given by equations in the text. The maximum line-of-sight distance between two elevated antennas is equal to the sum of their distances to the horizon as indicated here.



**Fig 6—**Distance to the horizon from an antenna of given height. The solid curve includes the effect of atmospheric refraction. The optical line-of-sight distance is given by the broken curve.

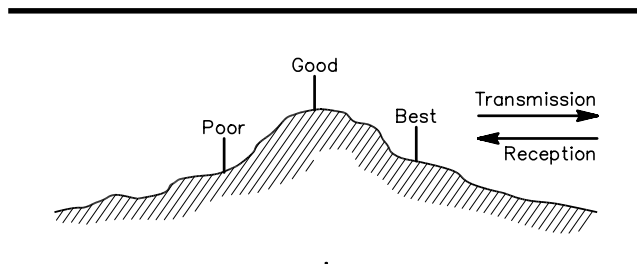
nearby buildings, trees, wires and surrounding terrain. A hill that rises above the rest of the countryside is a good location for an amateur station of any kind, and particularly so for extensive coverage on the frequencies above 50 MHz. The highest point on such an eminence is not necessarily the best location for the antenna. In the example shown in **Fig 7**, the hilltop would be a good site in all directions. But if maximum performance to the right is the objective, a point just below the crest might do better. This would involve a trade-off with reduced coverage in the opposite direction. Conversely, an antenna situated on the left side, lower down the hill, might do well to the left, but almost certainly would be inferior in performance to the right.

Selection of a home site for its radio potential is a complex business, at best. A VHF enthusiast dreams of the highest hill. The DX-minded ham may be more attracted by a dry spot near a salt marsh. A wide saltwater horizon, especially from a high cliff, just smells of DX. In shopping for ham radio real estate, a mobile or portable rig for the frequencies you're most interested in can provide useful clues.

### Antenna Polarization

If effective communication over long distances were the only consideration, we might be concerned mainly with radiation of energy at the lowest possible angle above the horizon. However, being engaged in a residential avocation often imposes practical restrictions on our antenna projects. As an example, our 1.8 and 3.5-MHz bands are used primarily for short-distance communication because they serve that purpose with antennas that are not difficult or expensive to put up. Out to a few hundred miles, simple wire antennas for these bands do well, even though their radiation is mostly at high angles above the horizon. Vertical systems might be better for long-distance use, but they require extensive ground systems for good performance.

Horizontal antennas that radiate well at low angles are most easily erected for 7 MHz and higher frequencies—horizontal wires and arrays are almost standard practice for work on 7 through 29.7 MHz. Vertical antennas are also used in this frequency range, such as a single omnidirectional antenna of multiband design. An antenna of this type may be



**Fig 7—**Propagation conditions are generally best when the antenna is located slightly below the top of a hill on the side facing the distant station. Communication is poor when there is a sharp rise immediately in front of the antenna in the direction of communication.

a good solution to the space problem for a city dweller on a small lot, or even for the resident of an apartment building.

High-gain antennas are almost always used at 50 MHz and higher frequencies, and most of them are horizontal. The principal exception is mobile communication with FM through repeaters, discussed in [Chapter 17](#). The height question is answered easily for VHF enthusiasts—the higher the better.

The theoretical and practical effects of height above ground at HF are treated in detail in [Chapter 3](#). Note that it is the height in wavelengths that is important—a good reason to think in the metric system, rather than in feet and inches.

In working locally on any amateur frequency band, best results will be obtained with the same polarization at both stations, except on rare occasions when polarization shift is caused by terrain obstructions or reflections from buildings. Where such a shift is observed, mostly above 100 MHz or so, horizontal polarization tends to work better than vertical. This condition is found primarily on short paths, so it is not too important. Polarization shift may occur on long paths where tropospheric bending is a factor, but here the effect tends to be random. Long-distance communication by way of the ionosphere produces random polarization effects routinely, so polarization matching is of little or no importance. This is fortunate for the HF mobile enthusiast, who will find that even his short, inductively loaded whips work very well at all distances other than local.

Because it responds to all plane polarizations equally, circular polarization may pay off on circuits where the arriving polarization is random, but it exacts a 3-dB penalty when used with a single-plane polarization of any kind. Circular systems find greatest use in work with orbiting satellites. It should be remembered that “horizontal” and “vertical” are meaningless terms in space, where the plane-Earth reference is lost.

### **Polarization Factors Above 50 MHz**

In most VHF communication over short distances, the polarization of the space wave tends to remain constant. Polarization discrimination is high, usually in excess of 20 dB, so the same polarization should be used at both ends of the circuit. Horizontal, vertical and circular polarization all have certain advantages above 50 MHz, so there has never been complete standardization on any one of them.

Horizontal systems are popular, in part because they tend to reject man-made noise, much of which is vertically polarized. There is some evidence that vertical polarization shifts to horizontal in hilly terrain, more readily than horizontal shifts to vertical. With large arrays, horizontal systems may be easier to erect, and they tend to give higher signal strengths over irregular terrain, if any difference is observed.

Practically all work with VHF mobiles is now handled with vertical systems. For use in a VHF repeater system, the vertical antenna can be designed to have gain without losing the desired omnidirectional quality. In the mobile station a small vertical whip has obvious aesthetic advantages. Often

a telescoping whip used for broadcast reception can be pressed into service for the 144-MHz FM rig. A car-top mount is preferable, but the broadcast whip is a practical compromise. Tests with at least one experimental repeater have shown that horizontal polarization can give a slightly larger service area, but mechanical advantages of vertical systems have made them the almost unanimous choice in VHF FM communication. Except for the repeater field, horizontal is the standard VHF system almost everywhere.

In communication over the Earth-Moon-Earth (EME) route the polarization picture is blurred, as might be expected with such a diverse medium. If the moon were a flat target, we could expect a 180° phase shift from the moon reflection process. But it is not flat. This plus the moon’s libration, and the fact that waves must travel both ways through the Earth’s entire atmosphere and magnetic field, provide other variables that confuse the phase and polarization issue. Building a huge array that will track the moon, and give gains in excess of 20 dB, is enough of a task that most EME enthusiasts tend to take their chances with phase and polarization problems. Where rotation of the element plane has been tried it has helped to stabilize signal levels, but it is not widely employed.

### **TROPOSPHERIC PROPAGATION OF VHF WAVES**

The effects of changes in the dielectric constant of the propagation medium were discussed earlier. Varied weather patterns over most of the Earth’s surface can give rise to boundaries between air masses of very different temperature and humidity characteristics. These boundaries can be anything from local anomalies to air-circulation patterns of continental proportions.

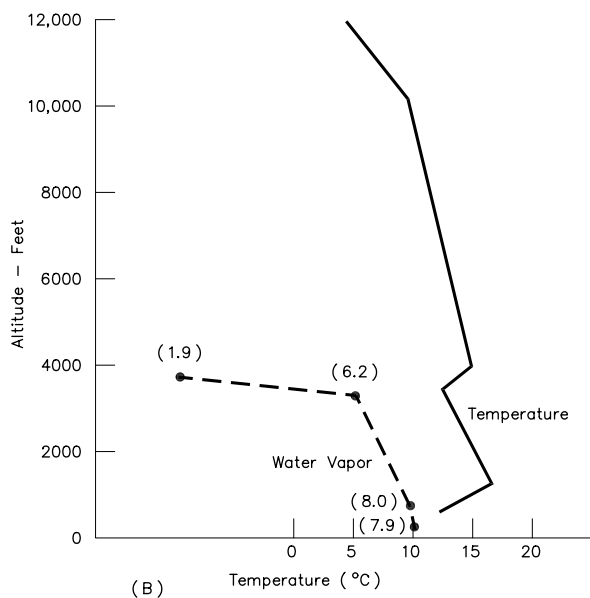
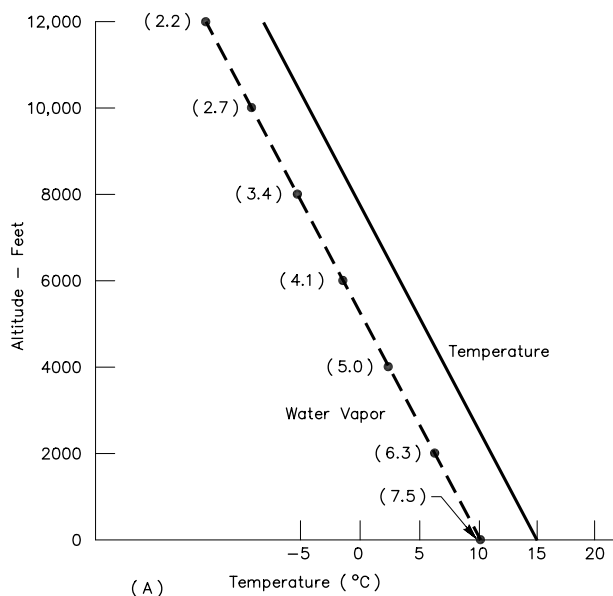
Under stable weather conditions, large air masses can retain their characteristics for hours or even days at a time. See [Fig 8](#). Stratified warm dry air over cool moist air, flowing slowly across the Great Lakes region to the Atlantic Seaboard, can provide the medium for east-west communication on 144 MHz and higher amateur frequencies over as much as 1200 miles. More common, however, are communication distances of 400 to 600 miles under such conditions.

A similar inversion along the Atlantic Seaboard as a result of a tropical storm air-circulation pattern may bring VHF and UHF openings extending from the Maritime Provinces of Canada to the Carolinas. Propagation across the Gulf of Mexico, sometimes with very high signal levels, enlivens the VHF scene in coastal areas from Florida to Texas. The California coast, from below the San Francisco Bay Area to Mexico, is blessed with a similar propagation aid during the warmer months. Tropical storms moving west, across the Pacific below the Hawaiian Islands, may provide a transpacific long-distance VHF medium. This was first exploited by amateurs on 144, 220 and 432 MHz, in 1957. It has been used fairly often in the summer months since, although not yearly.

The examples of long-haul work cited above may occur

infrequently, but lesser extensions of the minimum operating range are available almost daily. Under minimum conditions there may be little more than increased signal strength over paths that are workable at any time.

There is a diurnal effect in temperate climates. At sunrise the air aloft is warmed more rapidly than that near the



**Fig 8—Upper air conditions that produce extended-range communication on the VHF bands. At the top is shown the US Standard Atmosphere temperature curve. The humidity curve (dotted) is what would result if the relative humidity were 70%, from ground level to 12,000 feet elevation. There is only slight refraction under this standard condition. At the bottom is shown a sounding that is typical of marked refraction of VHF waves. Figures in parentheses are the “mixing ratio”—grams of water vapor per kilogram of dry air. Note the sharp break in both curves at about 3500 feet.**

Earth’s surface, and as the Sun goes lower late in the day the upper air is kept warm, while the ground cools. In fair, calm weather the sunrise and sunset temperature inversions can improve signal strength over paths beyond line of sight as much as 20 dB over levels prevailing during the hours of high sun. The diurnal inversion may also extend the operating range for a given strength by some 20 to 50%. If you would be happy with a new VHF antenna, try it first around sunrise!

There are other short-range effects of local atmospheric and topographical conditions. Known as *subsidence*, the flow of cool air down into the bottom of a valley, leaving warm air aloft, is a familiar summer-evening pleasure. The daily inshore-offshore wind shift along a seacoast in summer sets up daily inversions that make coastal areas highly favored as VHF sites. Ask any jealous 144-MHz operator who lives more than a few miles inland!

Tropospheric effects can show up at any time, in any season. Late spring and early fall are the most favored periods, although a winter warming trend can produce strong and stable inversions that work VHF magic almost equal to that of the more familiar spring and fall events.

Regions where the climate is influenced by large bodies of water enjoy the greatest degree of tropospheric bending. Hot, dry desert areas see little of it, at least in the forms described above.

### Tropospheric Ducting

Tropospheric propagation of VHF and UHF waves can influence signal levels at all distances from purely local to something beyond 4000 km (2500 miles). The outer limits are not well known. At the risk of over simplification, we will divide the modes into two classes—extended local and long distance. This concept must be modified depending on the frequency under consideration, but in the VHF range the extended-local effect gives way to a form of propagation much like that of microwaves in a waveguide, called *ducting*. The transition distance is ordinarily somewhere around 200 miles. The difference lies in whether the atmospheric condition producing the bending is localized or continental in scope. Remember, we’re concerned here with frequencies in the VHF range, and perhaps up to 500 MHz. At 10 GHz, for example, the scale is much smaller.

In VHF propagation beyond a few hundred miles, more than one weather front is probably involved, but the wave is propagated between the inversion layers and ground, in the main. On long paths over the ocean (two notable examples are California to Hawaii and Ascension Island to Brazil), propagation is likely to be between two atmospheric layers. On such circuits the communicating station antennas must be in the duct, or capable of propagating strongly into it. Here again, we see that the positions and radiation angles of the antennas are important. As with microwaves in a waveguide, the low-frequency limit for the duct is critical. In long-distance ducting it is also very variable. Airborne equipment has shown that duct capability exists well down into the HF region in the stable atmosphere west of Ascension Island. Some contacts between Hawaii and Southern

California on 50 MHz are believed to have been by way of tropospheric ducts. Probably all contact over these paths on 144 MHz and higher bands is because of duct propagation.

Amateurs have played a major part in the discovery and eventual explanation of tropospheric propagation. In recent years they have shown that, contrary to beliefs widely held in earlier times, long-distance communication using tropospheric modes is possible to some degree on all amateur frequencies from 50 to at least 10,000 MHz.

### RELIABLE VHF COVERAGE

In the preceding sections we discussed means by which amateur bands above 50 MHz may be used intermittently for communication far beyond the visual horizon. In emphasizing distance we should not neglect a prime asset of the VHF band: reliable communication over relatively short distances. The VHF region is far less subject to disruption of local communication than are frequencies below 30 MHz. Since much amateur communication is essentially local in nature, our VHF assignments can carry a great load, and such use of the VHF bands helps solve interference problems on lower frequencies.

Because of age-old ideas, misconceptions about the coverage obtainable in our VHF bands persist. This reflects the thoughts that VHF waves travel only in straight lines, except when the DX modes described above happen to be present. However, let us survey the picture in the light of modern wave-propagation knowledge and see what the bands above 50 MHz are good for on a day-to-day basis, ignoring the anomalies that may result in extensions of normal coverage.

It is possible to predict with fair accuracy how far you should be able to work consistently on any VHF or UHF band, provided a few simple facts are known. The factors affecting operating range can be reduced to graph form, as described in this section. The information was originally published in November 1961 *QST* by **D. W. Bray, K2LMG** (see the Bibliography at the end of this chapter).

To estimate your station's capabilities, two basic numbers must be determined: station gain and path loss. Station gain is made up of seven factors: receiver sensitivity, transmitted power, receiving antenna gain, receiving antenna height gain, transmitting antenna gain, transmitting antenna height gain and required signal-to-noise ratio. This looks complicated but it really boils down to an easily made evaluation of receiver, transmitter, and antenna performance. The other number, path loss, is readily determined from the nomogram, **Fig 9**. This gives path loss over smooth Earth, for 99% reliability.

For 50 MHz, lay a straightedge from the distance between stations (left side) to the appropriate distance at the right side. For 1296 MHz, use the full scale, right center. For 144, 222 and 432, use the dot in the circle, square or triangle, respectively. Example: At 300 miles the path loss for 144 MHz is 214 dB.

To be meaningful, the losses determined from this nomogram are necessarily greater than simple free-space

path losses. As described in an earlier section, communication beyond line-of-sight distances involves propagation modes that increase the path attenuation with distance.

### VHF/UHF Station Gain

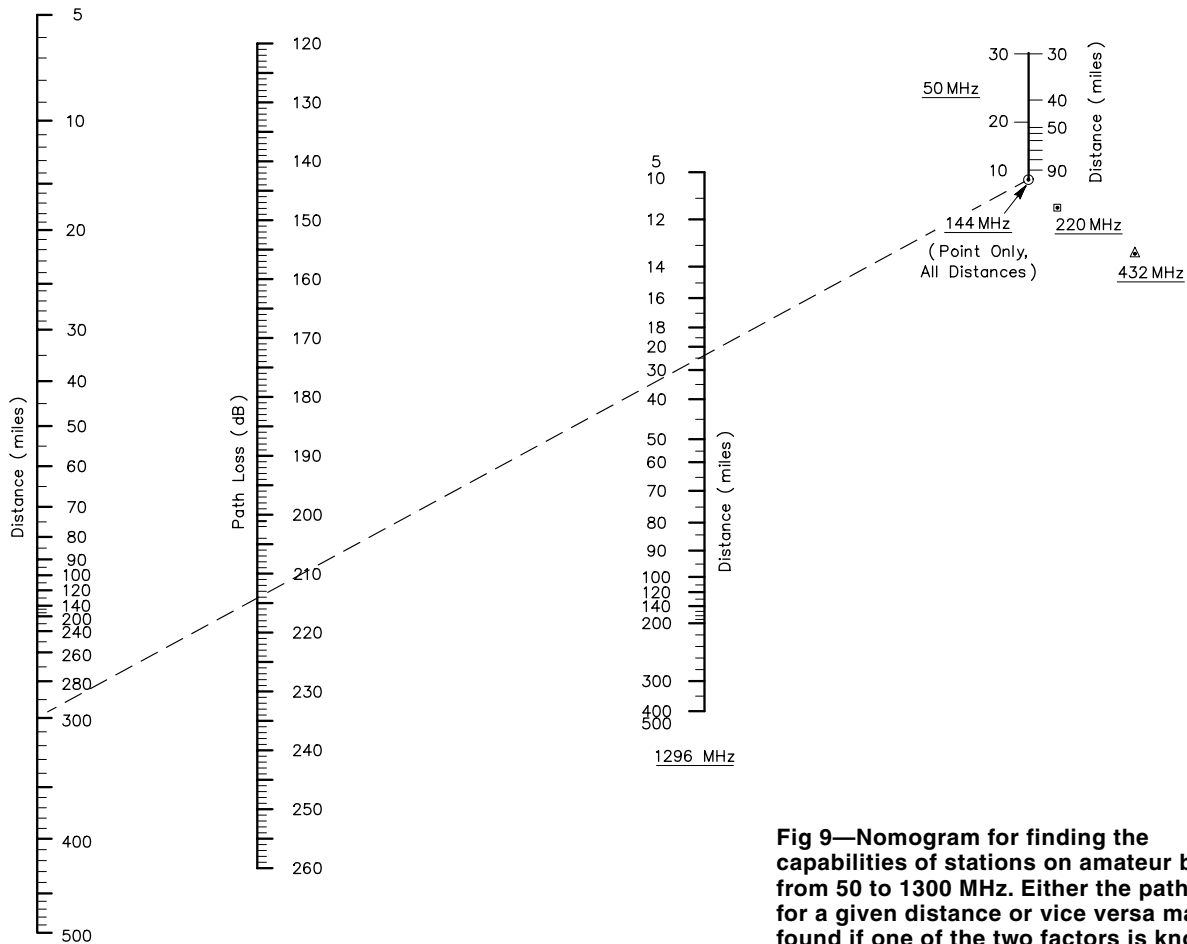
The largest of the eight factors involved in station design is receiver sensitivity. This is obtainable from **Fig 10**, if you know the approximate receiver noise figure and transmission-line loss. If you can't measure noise figure, assume 3 dB for 50 MHz, 5 for 144 or 222, 8 for 432 and 10 for 1296 MHz, if you know your equipment is working moderately well. These noise figures are well on the conservative side for modern solid-state receivers.

Line loss can be taken from information in **Chapter 24** for the line in use, if the antenna system is fed properly. Lay a straightedge between the appropriate points at either side of **Fig 10**, to find effective receiver sensitivity in decibels below 1 watt (dBW). Use the narrowest bandwidth that is practical for the emission intended, with the receiver you will be using. For CW, an average value for effective work is about 500 Hz. Phone bandwidth can be taken from the receiver instruction manual, but it usually falls between 2.1 to 2.7 kHz.

Antenna gain is next in importance. Gains of amateur antennas are often exaggerated. For well-designed Yagis they run close to 10 times the boom length in wavelengths. (Example: A 24-foot Yagi on 144 MHz is 3.6 wavelengths long;  $3.6 \times 10 = 36$ , or about  $15\frac{1}{2}$  dB.) Add 3 dB for stacking, where used properly. Add 4 dB more for ground reflection gain. This varies in amateur work, but averages out near this figure.

We have one more plus factor—antenna height gain, obtained from **Fig 11**. Note that this is greatest for short distances. The left edge of the horizontal center scale is for 0 to 10 miles, the right edge for 100 to 500 miles. Height gain for 10 to 30 feet is assumed to be zero. It will be seen that for 50 feet the height gain is 4 dB at 10 miles, 3 dB at 50 miles, and 2 dB at 100 miles. At 80 feet the height gains are roughly 8, 6 and 4 dB for these distances. Beyond 100 miles the height gain is nearly uniform for a given height, regardless of distance.

Transmitter power output must be stated in decibels above 1 watt. If you have 500 watts output, add  $10 \log (500/1)$ , or 27 dB, to your station gain. The transmission-line loss must be subtracted from the station gain. So must the required signal-to-noise ratio. The information is based on CW work, so the additional signal needed for other modes must be subtracted. Use a figure of 3 dB for SSB. Fading losses must be accounted for also. It has been shown that for distances beyond 100 miles, the signal will vary plus or minus about 7 dB from the average level, so 7 dB must be subtracted from the station gain for high reliability. For distances under 100 miles, fading diminishes almost linearly with distance. For 50 miles, use -3.5 dB for fading.



**Fig 9—Nomogram for finding the capabilities of stations on amateur bands from 50 to 1300 MHz. Either the path loss for a given distance or vice versa may be found if one of the two factors is known.**

### What It All Means

Add all the plus and minus factors to get the station gain. Use the final value to find the distance over which you can expect to work reliably from the nomogram, Fig 9. Or work it the other way around: Find the path loss for the distance you want to cover from the nomogram and then figure out what station changes will be needed to overcome it.

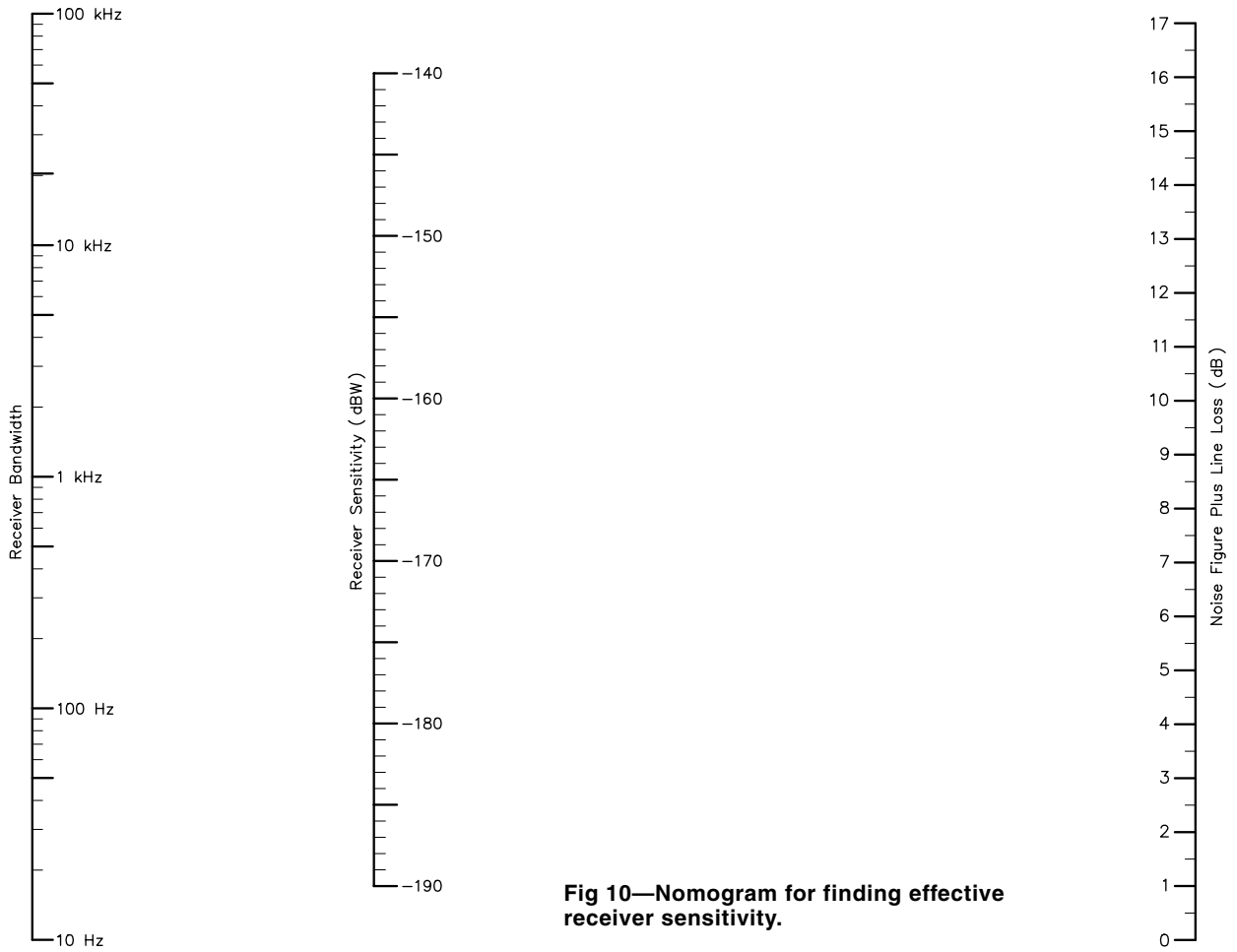
The significance of all this becomes more obvious when we see path loss plotted against frequency for the various bands, as in Fig 12. At the left this is done for 50% reliability. At the right is the same information for 99% reliability. For near-perfect reliability, a path loss of 195 dB (easily encountered at 50 or 144 MHz) is involved in 100-mile communication. But look at the 50% reliability curve: The same path loss takes us out to well over 250 miles. Few amateurs demand near-perfect reliability. By choosing our times, and by accepting the necessity for some repeats or occasional loss of signal, we can maintain communication out to distances far beyond those usually covered by VHF stations.

Working out a few typical amateur VHF station setups

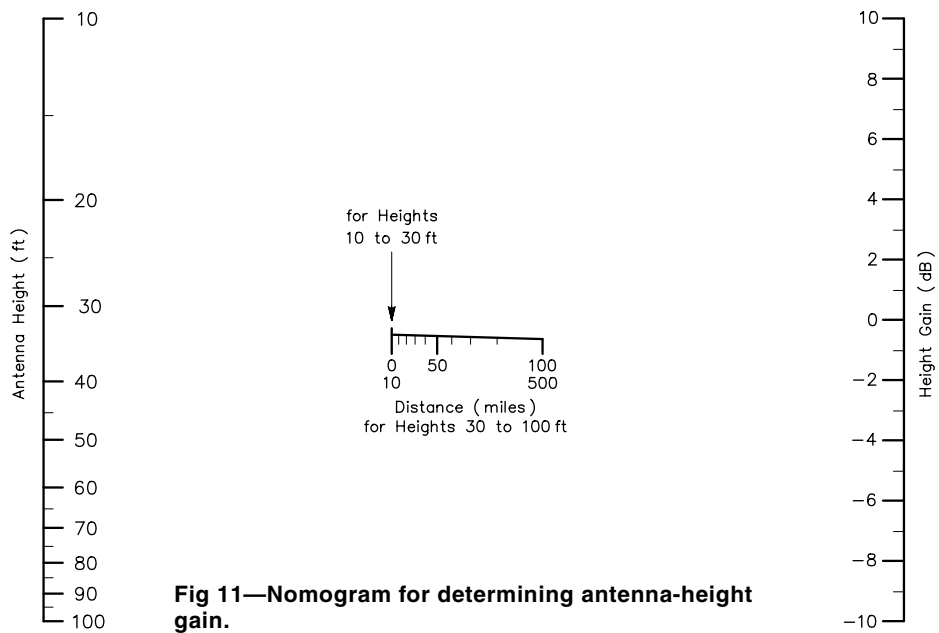
with these curves will show why an understanding of these factors is important to any user of the VHF spectrum. Note that path loss rises very steeply in the first 100 miles or so. This is no news to VHF operators; locals are very strong, but stations 50 or 75 miles away are much weaker. What happens beyond 100 miles is not so well known to many of us.

From the curves of Fig 12, we see that path loss levels off markedly at what is the approximate limit of working range for average VHF stations using wideband modulation modes. Work out the station gain for a 50-watt station with an average receiver and antenna, and you'll find that it comes out around 180 dB. This means you'd have about a 100-mile working radius in average terrain, for good but not perfect reliability. Another 10 dB may extend the range to as much as 250 miles. Just changing from AM phone to SSB and CW makes a major improvement in daily coverage on the VHF bands.

A bigger antenna, a higher one if your present beam is not at least 50 feet up, an increase in power to 500 watts from 50, an improvement in receiver noise figure if it is presently poor—any of these things can make a big

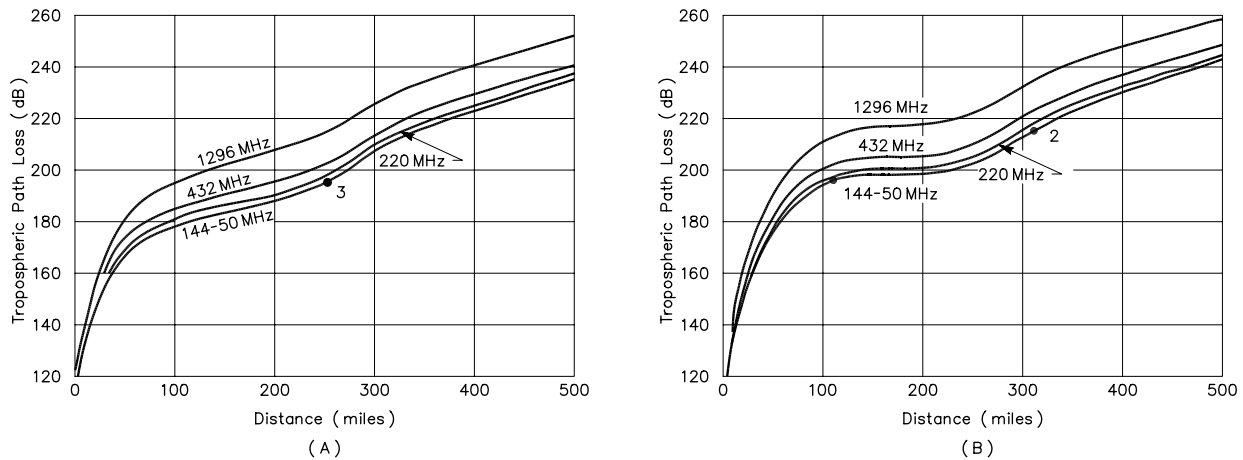


**Fig 10—Nomogram for finding effective receiver sensitivity.**



**Fig 11—Nomogram for determining antenna-height gain.**





**Fig 12—Path loss versus distance for amateur frequencies above 50 MHz. At A are curves for 50% of the time; at B, for 99%. The curves at A are more representative of Amateur Radio requirements.**

improvement in reliable coverage. Achieve all of them, and you will have very likely tripled your sphere of influence, thanks to that hump in the path-loss curves. This goes a long way toward explaining why using a 10-watt packaged station with a small antenna, fun though it may be, does not begin to show what the VHF bands are really good for.

### Terrain at VHF/UHF

The coverage figures derived from the above procedure are for average terrain. What of stations in mountainous country? Although an open horizon is generally desirable for the VHF station site, mountainous country should not be considered hopeless. Help for the valley dweller often lies in the optical phenomenon known as *knife-edge diffraction*. A flashlight beam pointed at the edge of a partition does not cut off sharply at the partition edge, but is diffracted around it, partially illuminating the shadow area. A similar effect is observed with VHF waves passing over ridges; there is a shadow effect, but not a complete blackout. If the signal is strong where it strikes the mountain range, it will be heard well in the bottom of a valley on the far side.

This is familiar to all users of VHF communications equipment who operate in hilly terrain. Where only one ridge lies in the way, signals on the far side may be almost as

good as on the near side. Under ideal conditions (a very high and sharp-edged obstruction near the midpoint of a long-enough path so that signals would be weak over average terrain), knife-edge diffraction may yield signals even stronger than would be possible with an open path.

The obstruction must project into the radiation patterns of the antennas used. Often mountains that look formidable to the viewer are not high enough to have an appreciable effect, one way or the other. Since the normal radiation from a VHF array is several degrees above the horizontal, mountains that are less than about three degrees above the horizon, as seen from the antenna, are missed by the radiation from the array. Moving the mountains out of the way would have substantially no effect on VHF signal strength in such cases.

Rolling terrain, where obstructions are not sharp enough to produce knife-edge diffraction, still does not exhibit a complete shadow effect. There is no complete barrier to VHF propagation—only attenuation, which varies widely as the result of many factors. Thus, even valley locations are usable for VHF communication. Good antenna systems, preferably as high as possible, the best available equipment, and above all, the willingness and ability to work with weak signals may make outstanding VHF work possible, even in sites that show little promise by casual inspection.

# Sky-Wave Propagation

As described earlier, the term “ground wave” is commonly applied to propagation that is confined to the Earth’s lower atmosphere. Now we will use the term “sky wave” to describe modes of propagation that use the Earth’s ionosphere. First, however, we must examine how the Earth’s ionosphere is affected by the Sun.

## THE ROLE OF THE SUN

Everything that happens in radio propagation, as with all life on Earth, is the result of radiation from the Sun. The variable nature of radio propagation here on Earth reflects the ever-changing intensity of ultraviolet and X-ray radiation, the primary ionizing agents in solar energy. Every day, solar nuclear reactions are turning hydrogen into helium, releasing an unimaginable blast of energy into space in the process. The total power radiated by the Sun is estimated at  $4 \times 10^{23}$  kW—that is, the number four followed by 23 zeroes. At its surface, the Sun creates about 60 *megawatts* per square meter. That is a very potent transmitter!

## The Solar Wind

The Sun is constantly ejecting material from its surface in all directions into space, making up the so-called *solar wind*. Under relatively quiet solar conditions the solar wind blows around 200 miles per second—675,000 miles per hour—taking away about two million tons of solar material each second from the Sun. You needn’t worry—the Sun is not going to shrivel up anytime soon. It’s big enough that it will take many billions of years before that happens.

A 675,000 mile/hour wind sounds like a pretty stiff breeze, doesn’t it? Lucky for us, the density of the material in the solar wind is very small by the time it has been spread out into interplanetary space. Scientists calculate that the density of the particles in the solar wind is less than that of the best vacuum they’ve ever achieved on Earth. Despite the low density of the material in the solar wind, the effect on the Earth, especially its magnetic field, is very significant.

Before the advent of sophisticated satellite sensors, the Earth’s magnetic field was considered to be fairly simple, modeled as if the Earth were a large bar magnet. The axis of this hypothetical bar magnet is oriented about  $11^\circ$  away from the geographic north-south pole. We now know that the solar wind alters the shape of the Earth’s magnetic field significantly, compressing it on the side facing the Sun and elongating it on the other side—in the same manner as the tail of a comet is stretched out radially in its orientation from the Sun. In fact, the solar wind is also responsible for the shape of a comet’s tail.

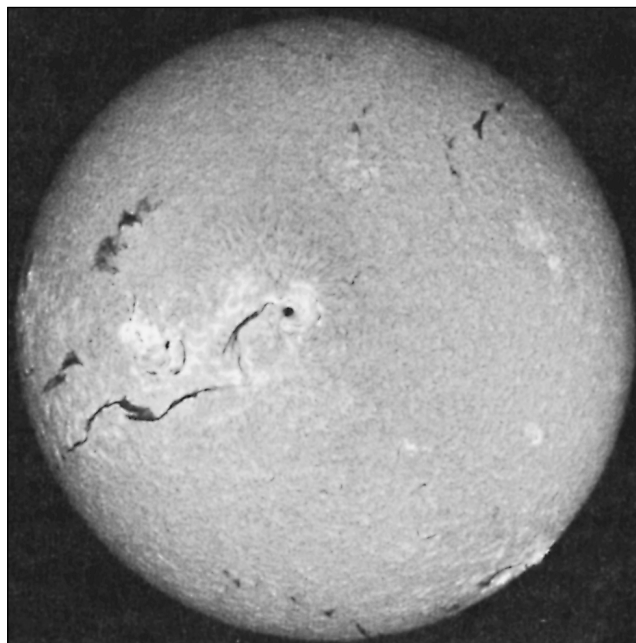
Partly because of the very nature of the nuclear reactions going on at the Sun itself, but also because of variations in the speed and direction of the solar wind, the interactions between the Sun and our Earth are incredibly complex. Even scientists who have studied the subject for years do not completely understand everything that happens

on the Sun. Later in this chapter, we’ll investigate the effects of the solar wind when conditions on the Sun are *not* “quiet.” As far as amateur HF skywave propagation is concerned, the results of disturbed conditions on the Sun are not generally beneficial!

## Sunspots

The most readily observed characteristic of the Sun, other than its blinding brilliance, is its tendency to have grayish black blemishes, seemingly at random times and at random places, on its fiery surface. (See **Fig 13**.) There are written records of naked-eye sightings of *sunspots* in the Orient back to more than 2000 years ago. As far as is known, the first indication that sunspots were recognized as part of the Sun was the result of observations by Galileo in the early 1600s, not long after he developed one of the first practical telescopes.

Galileo also developed the projection method for observing the Sun safely, but probably not before he had suffered severe eye damage by trying to look at the Sun directly. (He was blind in his last years.) His drawings of sunspots, indicating their variable nature and position, are the earliest such record known to have been made. His reward



**Fig 13**—Much more than sunspots can be seen when the sun is viewed through selective optical filters. This photo was taken through hydrogen-alpha filter that passes a narrow light segment at 6562 angstroms. The bright patches are active areas around and often between sunspots. Dark irregular lines are filaments of activity having no central core. Faint magnetic field lines are visible around a large sunspot group near the disc center. (Photo courtesy of *Sacramento Peak Observatory, Sunspot, New Mexico*).

for this brilliant work was immediate condemnation by church authorities of the time, which probably set back progress in learning more about the Sun for generations.

The systematic study of solar activity began about 1750, so a fairly reliable record of sunspot numbers goes back that far. (There are some gaps in the early data.) The record shows clearly that the Sun is always in a state of change. It never looks exactly the same from one day to the next. The most obvious daily change is the movement of visible activity centers (sunspots or groups thereof) across the solar disc, from east to west, at a constant rate. This movement was soon found to be the result of the rotation of the Sun, at a rate of approximately four weeks for a complete round. The average is about 27.5 days, the Sun's *synodic* rotation speed, viewed from the perspective of the Earth, which is also moving around the Sun in the same direction as the Sun's rotation.

### Sunspot Numbers

Since the earliest days of systematic observation, our traditional measure of solar activity has been based on a count of *sunspots*. In these hundreds of years we have learned that the average number of spots goes up and down in cycles very roughly approximating a sine wave. In 1848, a method was introduced for the daily measurement of sunspot numbers. That method, which is still used today, was devised by the Swiss astronomer Johann Rudolph Wolf. The observer counts the total number of spots visible on the face of the Sun and the number of groups into which they are clustered, because neither quantity alone provides a satisfactory measure of sunspot activity. The observer's sunspot number for that day is computed by multiplying the number of groups he sees by 10, and then adding to this value the number of individual spots. Where possible, sunspot data collected prior to 1848 have been converted to this system.

As can readily be understood, results from one observer to another can vary greatly, since measurement depends on the capability of the equipment in use and on the stability of the Earth's atmosphere at the time of observation, as well as on the experience of the observer. A number of observatories around the world cooperate in measuring solar activity. A weighted average of the data is used to determine the *International Sunspot Number* or ISN for each day. (Amateur astronomers can approximate the determination of ISN values by multiplying their values by a correction factor determined empirically.)

A major step forward was made with the development of various methods for observing narrow portions of the Sun's spectrum. Narrowband light filters that can be used with any good telescope perform a visual function very similar to the aural function of a sharp filter added to a communications receiver. This enables the observer to see the actual area of the Sun doing the radiating of the ionizing energy, in addition to the sunspots, which are more a by-product than a cause. The photo of Fig 13 was made through such a filter. Studies of the ionosphere with instrumented probes, and later with satellites, manned and unmanned, have

added greatly to our knowledge of the effects of the Sun on radio communication.

Daily sunspot counts are recorded, and monthly and yearly averages determined. The averages are used to see trends and observe patterns. Sunspot records were formerly kept in Zurich, Switzerland, and the values were known as *Zurich Sunspot Numbers*. They were also known as Wolf sunspot numbers. The official international sunspot numbers are now compiled at the Sunspot Index Data Center in Bruxelles, Belgium.

The yearly means (averages) of sunspot numbers from 1700 through 1986 are plotted in Fig 14. The cyclic nature of solar activity becomes readily apparent from this graph. The duration of the cycles varies from 9.0 to 12.7 years, but averages approximately 11.1 years, usually referred to as the 11-year solar cycle. The first complete cycle to be observed systematically began in 1755, and is numbered Cycle 1. Solar cycle numbers thereafter are consecutive. Cycle 23 began in October 1996.

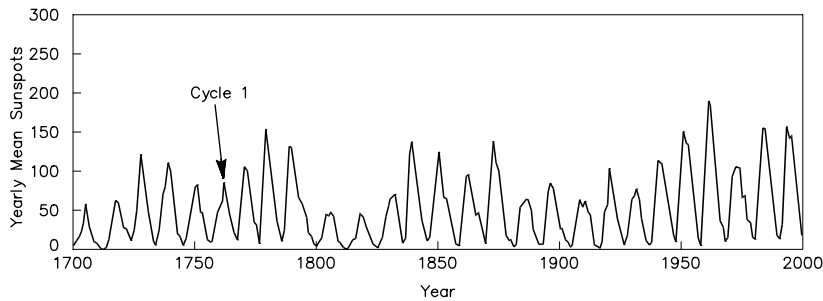
### The "Quiet" Sun

For more than 50 years it has been well known that radio propagation phenomena vary with the number and size of sunspots, and also with the position of sunspots on the surface of the Sun. There are daily and seasonal variations in the Earth's ionized layers resulting from changes in the amount of ultraviolet light received from the Sun. The 11-year sunspot cycle affects propagation conditions because there is a direct correlation between sunspot activity and ionization.

Activity on the surface of the Sun is changing continually. In this section we want to describe the activity of the so-called *quiet Sun*, meaning those times when the Sun is not doing anything more spectacular than acting like a "normal" thermonuclear ball of flaming gases! The Sun and its effects on Earthly propagation can be described in "statistical" terms—that's what the 11-year solar cycle does. You may experience vastly different conditions on any particular day compared to what a long-term average would suggest.

An analogy may be in order here. Have you ever gazed into a relatively calm campfire and been surprised when suddenly a flaming ember or a large spark was ejected in your direction? The Sun can also do unexpected and sometimes very dramatic things. Disturbances of propagation conditions here on Earth are caused by disturbed conditions on the Sun. More on this later.

Individual sunspots may vary in size and appearance, or even disappear totally, within a single day. In general, larger active areas persist through several rotations of the Sun. Some active areas have been identified over periods up to about a year. Because of these continual changes in solar activity, there are continual changes in the state of the Earth's ionosphere and resulting changes in propagation conditions. A short-term burst of solar activity may trigger unusual propagation conditions here on Earth lasting for less than an hour.



**Fig 14—Yearly means of sunspot numbers from data for 1700 through 1986. This plot clearly shows that sunspot activity takes place in cycles of approximately 11 years duration. Cycle 1, the first complete cycle to be examined by systematic observation, began in 1755.**

### Smoothed Sunspot Numbers (SSN)

Sunspot data are averaged or smoothed to remove the effects of short-term changes. The sunspot values used most often for correlating propagation conditions are *Smoothed Sunspot Numbers* (SSN), often called 12-month running average values. Data for 13 consecutive months are required to determine a smoothed sunspot number.

Long-time users have found that the upper HF bands are reliably open for propagation only when the average number of sunspots is above certain minimum levels. For example, between mid 1988 to mid 1992 during Cycle 22, the SSN stayed higher than 100. The 10-meter band was open then almost all day, every day, to some part of the world. However, by mid 1996, few if any sunspots showed up on the Sun and the 10-meter band consequently was rarely open. Even 15 meters, normally a workhorse DX band when solar activity is high, was closed most of the time during the low point in Cycle 22. So far as propagation on the upper HF bands is concerned, the higher the sunspot number, the better the conditions.

Each smoothed number is an average of 13 monthly means, centered on the month of concern. The 1st and 13th months are given a weight of 0.5. A monthly mean is simply the sum of the daily ISN values for a calendar month, divided by the number of days in that month. We would commonly call this value a monthly average.

This may all sound very complicated, but an example should clarify the procedure. Suppose we wished to calculate the smoothed sunspot number for June 1986. We would require monthly mean values for six months prior and six months after this month, or from December 1985 through December 1986. The monthly mean ISN values for these months are

Dec 85	17.3	Jul 86	18.1
Jan 86	2.5	Aug 86	7.4
Feb 86	23.2	Sep 86	3.8
Mar 86	15.1	Oct 86	35.4
Apr 86	18.5	Nov 86	15.2
May 86	13.7	Dec 86	6.8
Jun 86	1.1		

First we find the sum of the values, but using only one-half the amounts indicated for the first and 13th months in

the listing. This value is 166.05. Then we determine the smoothed value by dividing the sum by 12:  $166.05/12 = 13.8$ . (Values beyond the first decimal place are not warranted.) Thus, 13.8 is the smoothed sunspot number for June 1986. From this example, you can see that the smoothed sunspot number for a particular month cannot be determined until six months afterwards.

Generally the plots we see of sunspot numbers are averaged data. As already mentioned, smoothed numbers make it easier to observe trends and see patterns, but sometimes this data can be misleading. The plots tend to imply that solar activity varies smoothly, indicating, for example, that at the onset of a new cycle the activity just gradually increases. But this is definitely not so! On any one day, significant changes in solar activity can take place within hours, causing sudden band openings at frequencies well above the MUF values predicted from smoothed sunspot number curves. The durations of such openings may be brief, or they may recur for several days running, depending on the nature of the solar activity.

### Solar Flux

Since the late 1940s an additional method of determining solar activity has been put to use—the measurement of *solar radio flux*. The quiet Sun emits radio energy across a broad frequency spectrum, with a slowly varying intensity. Solar flux is a measure of energy received per unit time, per unit area, per unit frequency interval. These radio fluxes, which originate from atmospheric layers high in the Sun's chromosphere and low in its corona, change gradually from day to day, in response to the activity causing sunspots. Thus, there is a degree of correlation between solar flux values and sunspot numbers.

One solar flux unit equals  $10^{-22}$  joules per second per square meter per hertz. Solar flux values are measured daily at 2800 MHz (10.7 cm) at The Dominion Radio Astrophysical Observatory, Penticton, British Columbia, where daily data have been collected since 1991. (Prior to June 1991, the Algonquin Radio Observatory, Ontario, made the measurements.) Measurements are also made at other observatories around the world, at several frequencies. With some variation, the daily measured flux values increase with increasing frequency of measurement, to at least 15.4 GHz.

The daily 2800-MHz Penticton value is sent to Boulder, Colorado, where it is incorporated into WWV propagation bulletins (see later section). Daily solar flux information is of value in determining current propagation conditions, as sunspot numbers on a given day do not relate directly to maximum usable frequency. Solar flux values are much more reliable for this purpose.

### Correlating Sunspot Numbers and Solar Flux Values

Based on historical data, an exact mathematical relationship does not exist to correlate sunspot data and solar flux values. Comparing daily values yields almost no correlation. Comparing monthly mean values (often called monthly averages) produces a degree of correlation, but the spread in data is still significant. This is indicated in **Fig 15**, a scatter diagram plot of monthly mean sunspot numbers versus the monthly means of solar flux values adjusted to one astronomical unit. (This adjustment applies a correction for differences in distance between the Sun and the Earth at different times of the year.)

A closer correlation exists when smoothed (12-month running average) sunspot numbers are compared with smoothed (12-month running average) solar flux values adjusted to one astronomical unit. A scatter diagram for smoothed data appears in **Fig 16**. Note how the plot points establish a better defined pattern in Fig 16. The correlation is still no better than a few percent, for records indicate a given smoothed sunspot number does not always correspond with the same smoothed solar flux value, and vice versa. **Table 1** illustrates some of the inconsistencies that exist in the historical data. Smoothed or 12-month running average values are shown.

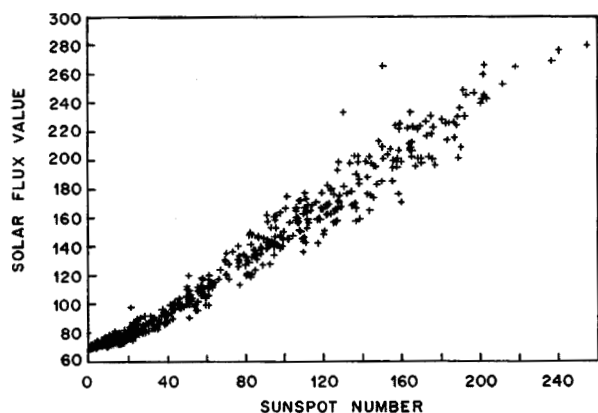
Even though there is no precise mathematical relationship between sunspot numbers and solar flux values, it is helpful to have some way to convert from one to the other. The primary reason is that sunspot numbers are valuable as a long-term link with the past, but the great usefulness of solar flux values are their immediacy, and their direct bearing on our field of interest. (Remember, a smoothed sunspot number will not be calculated until six months after the fact.)

The following mathematical approximation has been derived to convert a smoothed sunspot number to a solar flux value.

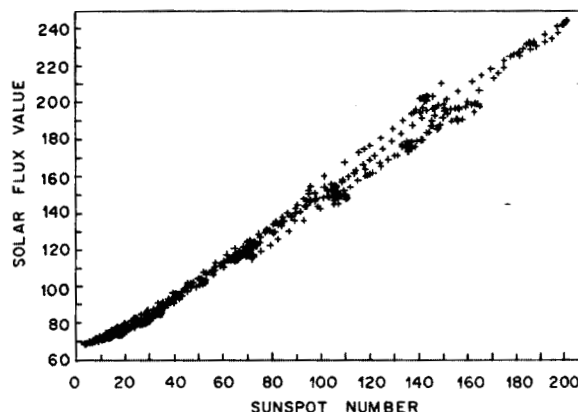
$$F = 63.75 + 0.728S + 0.00089 S^2 \quad (\text{Eq 5})$$

**Table 1**  
Selected Historical Data Showing Inconsistent Correlation Between Sunspot Number and Solar Flux

Month	Smoothed Sunspot Number	Smoothed Solar Flux Value
May 1953	17.4	75.6
Sept 1965	17.4	78.5
Jul 1985	17.4	74.7
Jun 1969	106.1	151.4
Jul 1969	105.9	151.4
Dec 1982	94.6	151.4
Aug 1948	141.1	180.5
Oct 1959	141.1	192.3
Apr 1979	141.1	180.4
Aug 1981	141.1	203.3



**Fig 15**—Scatter diagram or X-Y plot of monthly mean sunspot numbers and monthly mean 2800-MHz solar flux values. Data values are from February 1947 through February 1987. Each “+” mark represents the intersection of data for a given month. If the correlation between sunspot number and flux values were consistent, all the marks would align to form a smooth curve.



**Fig 16**—Scatter diagram of smoothed, or 12-month running averages, sunspot numbers versus 2800-MHz solar flux values. The correlation of smoothed values is better than for monthly means, shown in Fig 15.

where

F = solar flux number

S = smoothed sunspot number

A graphic representation of this equation is given in **Fig 17**. Use this chart to make conversions graphically, rather than by calculations. With the graph, solar flux and sunspot number conversions can be made either way. The equation has been found to yield errors as great as 10% when historical data was examined. (Look at the August 1981 data in **Table 1**.) Therefore, conversions should be rounded to the nearest whole number, as additional decimal places are unwarranted. To make conversions from flux to sunspot number, the following approximation may be used.

$$S = 33.52\sqrt{85.12 + F} - 408.99 \quad (\text{Eq 6})$$

### THE UNDISTURBED IONOSPHERE

There will be inevitable “gray areas” in our discussion of the Earth’s atmosphere and the changes wrought in it by the Sun and by associated changes in the Earth’s magnetic field. This is not a story that can be told in neat equations, or values carried out to a satisfying number of decimal places. The story must be told, and understood—with its well-known limitations—if we are to put up good antennas and make them serve us well.

Thus far in this chapter we have been concerned with what might be called our above-ground living space—that portion of the total atmosphere wherein we can survive

without artificial breathing aids, or up to about 6 km (4 miles). The boundary area is a broad one, but life (and radio propagation) undergo basic changes beyond this zone. Somewhat farther out, but still technically within the Earth’s atmosphere, the role of the Sun in the wave-propagation picture is a dominant one.

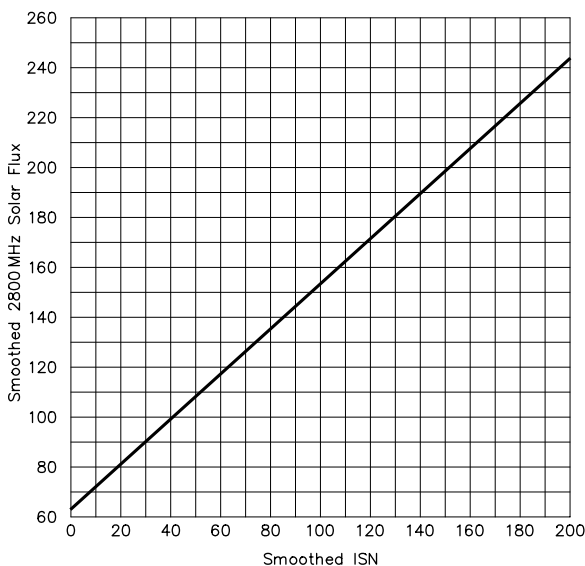
This is the *ionosphere*—a region where the air pressure is so low that free electrons and ions can move about for some time without getting close enough to recombine into neutral atoms. A radio wave entering this rarefied atmosphere, a region of relatively many free electrons, is affected in the same way as in entering a medium of different dielectric constant—its direction of travel is altered.

Ultraviolet (UV) radiation from the Sun is the primary cause of ionization in the outer regions of the atmosphere, the ones most important for HF propagation. However, there are other forms of solar radiation as well, including both hard and soft x-rays, gamma rays and extreme ultraviolet (EUV). The radiated energy breaks up, or *photoionizes*, molecules of atmospheric gases into electrons and positively charged ions. The degree of ionization does not increase uniformly with distance from the Earth’s surface. Instead there are relatively dense regions (layers) of ionization, each quite thick and more or less parallel to the Earth’s surface, at fairly well-defined intervals outward from about 40 to 300 km (25 to 200 miles). These distinct layers are formed due to complex photochemical reactions of the various types of solar radiation with oxygen, ozone, nitrogen and nitrous oxide in the rarefied upper atmosphere.

Ionization is not constant within each layer, but tapers off gradually on either side of the maximum at the center of the layer. The total ionizing energy from the Sun reaching a given point, at a given time, is never constant, so the height and intensity of the ionization in the various regions will also vary. Thus, the practical effect on long-distance communication is an almost continuous variation in signal level, related to the time of day, the season of the year, the distance between the Earth and the Sun, and both short-term and long-term variations in solar activity. It would seem from all this that only the very wise or the very foolish would attempt to predict radio propagation conditions, but it is now possible to do so with a fair chance of success. It is possible to plan antenna designs, particularly the choosing of antenna heights, to exploit known propagation characteristics.

### Layer Characteristics

The lowest known ionized region, called the *D layer*, lies between 60 and 92 km (37 to 57 miles) above the Earth. In this relatively low and dense part of the atmosphere, atoms broken up into ions by sunlight recombine quickly, so the ionization level is directly related to sunlight. It begins at sunrise, peaks at local noon and disappears at sundown. When electrons in this dense medium are set in motion by a passing wave, collisions between particles are so frequent that a major portion of their energy may be used up as heat, as the electrons and disassociated ions recombine.



**Fig 17—Chart for conversions between smoothed International Sunspot Numbers and smoothed 2800-MHz solar flux. This curve is based on the mathematical approximation given in the text.**

The probability of collisions depends on the distance an electron travels under the influence of the wave—in other words, on the wavelength. Thus, our 1.8- and 3.5-MHz bands, having the longest wavelengths, suffer the highest daytime absorption loss, particularly for waves that enter the medium at the lowest angles. At times of high solar activity (peak years of the solar cycle) even waves entering the D layer vertically suffer almost total energy absorption around midday, making these bands almost useless for communication over appreciable distances during the hours of high sun. They “go dead” quickly in the morning, but come alive again the same way in late afternoon. The diurnal D-region effect is less at 7 MHz (though still marked), slight at 14 MHz and inconsequential on higher amateur frequencies.

The D layer is ineffective in bending HF waves back to Earth, so its role in long-distance communication by amateurs is largely a negative one. It is the principal reason why our frequencies up through the 7-MHz band are useful mainly for short-distance communication during the high-sun hours.

The lowest portion of the ionosphere useful for long-distance communication by amateurs is the *E region* or *E layer* about 100 to 115 km (62 to 71 miles) above the Earth. In the E layer, at intermediate atmospheric density, ionization varies with the Sun angle above the horizon, but solar ultraviolet radiation is not the sole ionizing agent. Solar X-rays and meteors entering this portion of the Earth’s atmosphere also play a part. Ionization increases rapidly after sunrise, reaches maximum around noon local time, and drops off quickly after sundown. The minimum is after midnight, local time. As with the D region, the E layer absorbs wave energy in the lower frequency amateur bands when the Sun angle is high, around mid-day. The other varied effects of E-region ionization will be discussed later.

Most of our long-distance communication capability stems from the tenuous outer reaches of the Earth’s atmosphere known as the *F region* or *F layer*. At heights above 100 miles, ions and electrons recombine more slowly, so the observable effects of the Sun develop more slowly. Also, the region holds its ability to reflect wave energy back to Earth well into the night. The *maximum usable frequency* (MUF) for F-layer propagation on east-west paths thus peaks just after noon at the midpoint, and the minimum occurs after midnight. We’ll examine the subject of MUF in more detail later.

Using the F region effectively is by no means that simple, however. The layer height may be from 160 to more than 500 km (100 to over 310 miles), depending on the season of the year, the latitudes, the time of day and, most capricious of all, what the Sun has been doing in the last few minutes and in perhaps the last three days before the attempt is made. The MUF between Eastern US and Europe, for example, has been anything from 7 to 70 MHz, depending on the conditions mentioned above, plus the point in the long-term solar activity cycle at which the check is made.

Propagation information tailored to amateur needs is

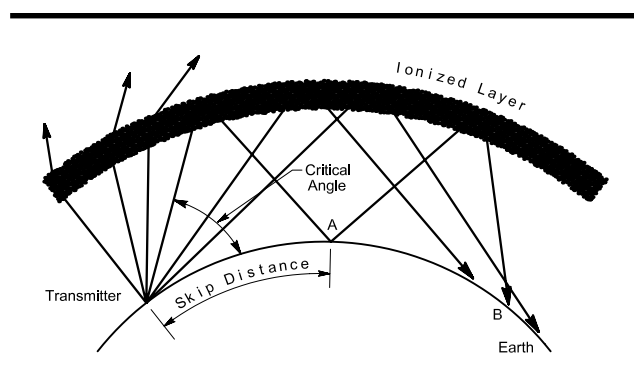
transmitted in all information bulletin periods by the ARRL Headquarters station, W1AW. Finally, solar and geomagnetic field data, transmitted hourly and updated eight times daily, are given in brief bulletins carried by the US Time Standard stations, WWV and WWVH. But more on these services later.

During the day the F region may split into two layers. The lower and weaker *F<sub>1</sub> layer*, about 160 km (100 miles) up, has only a minor role, acting more like the E than the *F<sub>2</sub> region*. At night the *F<sub>1</sub> layer* disappears and the *F<sub>2</sub> layer* height drops somewhat.

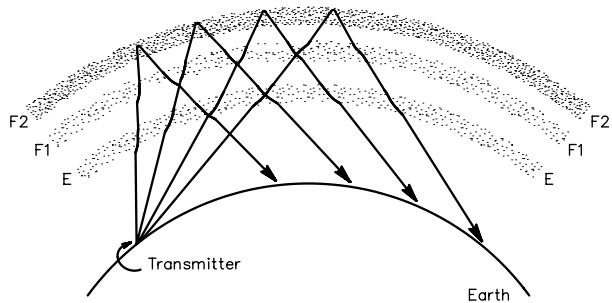
### Bending in the Ionosphere

The degree of bending of a wave path in an ionized layer depends on the density of the ionization and the length of the wave (inversely related to its frequency). The bending at any given frequency or wavelength will increase with increased ionization density. For a given ionization density, bending increases with wavelength (that is, decreases with frequency). Two extremes are thus possible. If the intensity of the ionization is sufficient and the frequency low enough, even a wave entering the layer perpendicularly will be reflected back to Earth. Conversely, if the frequency is high enough or the ionization decreases to a low enough density, a condition is reached where the wave angle is not affected enough by the ionosphere to cause a useful portion of the wave energy to return to the Earth. This basic principle has been used for many years to “sound” the ionosphere to determine its communication potential at various wave angles and frequencies.

A simplified example, showing only one layer, is given in **Fig 18**. The effects of additional layers are shown in **Fig 19**. The simple case in Fig 18 illustrates several important facts about antenna design for long-distance communication.



**Fig 18—Behavior of waves encountering the ionosphere. Rays entering the ionized region at angles above the critical angle are not bent enough to be returned to Earth, and are lost to space. Waves entering at angles below the critical angle reach the Earth at increasingly greater distances as the launch angle approaches the horizontal. The maximum distance that may normally be covered in a single hop is 4000 km. Greater distances are covered with multiple hops.**



**Fig 19—Typical daytime propagation of high frequencies (14 to 28 MHz). The waves are partially bent going through the E and F<sub>1</sub> layers, but not enough to be returned to Earth. The actual reflection is from the F<sub>2</sub> layer.**

At the left we see three waves that will do us no good—they all take off at angles high enough that they pass through the layer and are lost in space. Note that as the angle of radiation decreases (that is, the wave is launched closer to the horizon) the amount of bending needed for sky-wave communication also decreases. The fourth wave from the left takes off at what is called the *critical angle*—the highest that will return the wave to Earth at a given density of ionization in the layer for the frequency under consideration.

We can communicate with point A at this frequency, but not any closer to our transmitter site. Under this set of conditions of layer height, layer density and wave angle, we cannot communicate much farther than point A. But suppose we install an antenna that radiates at a lower angle, as with the fifth wave from the left. This will bring our signals down to Earth appreciably farther away than the higher (critical) angle did. Perhaps we can accomplish even more if we can achieve a very low radiation angle. Our sixth wave, with its radiation angle lower still, comes back to Earth much farther away, at point B.

The lowest wave drawn in Fig 18 reaches the Earth at a still greater distance, beyond point B. If the radio wave leaves the Earth at a radiation angle of zero degrees, just at the horizon, the maximum distance that may be reached under usual ionospheric conditions is about 4000 km (2500 miles).

The Earth itself acts as a reflector of radio waves. Often a radio signal will be reflected from the reception point on the Earth into the ionosphere again, reaching the Earth a second time at a still more distant point. This effect is also illustrated in Fig 18, where the critical-angle wave travels from the transmitter via the ionosphere to point A, in the center of the drawing. The signal reflected from point A travels by the ionosphere again to point B, at the right. Signal travel from the Earth through the ionosphere and back to the Earth is called a *hop*. Signal hopping is covered in more detail in a subsequent section.

In each case in Fig 18, the distance at which a ray reaches the Earth in a single hop depends on the launch

elevation angle at which it left the transmitting antenna, and this comes into play throughout this book. An amateur has some control of the launch angle by adjusting the height of the antennas he uses.

### Skip Distance

When the critical angle is less than 90° there will always be a region around the transmitting site where the ionospherically propagated signal cannot be heard, or is heard weakly. This area lies between the outer limit of the ground-wave range and the inner edge of energy return from the ionosphere. It is called the *skip zone*, and the distance between the originating site and the beginning of the ionospheric return is called the skip distance. This terminology should not be confused with ham jargon such as “the skip is in,” referring to the fact that a band is open for sky-wave propagation.

The signal may often be heard to some extent within the skip zone, through various forms of scattering, but it will ordinarily be marginal in strength. When the skip distance is short, both ground-wave and sky-wave signals may be received near the transmitter. In such instances the sky wave frequently is stronger than the ground wave, even as close as a few miles from the transmitter. The ionosphere is an efficient communication medium under favorable conditions. Comparatively, the ground wave is not.

### MULTIHOP PROPAGATION

In the interest of explanation and example, the information in Fig 18 is greatly simplified. On actual communication paths the picture is complicated by many factors. One is that the transmitted energy spreads over a considerable area after it leaves the antenna. Even with an antenna array having the sharpest practical beam pattern, there is what might be described as a *cone of radiation* centered on the wave lines (rays) shown in the drawing. The “reflection” in the ionosphere is also varied, and is the cause of considerable spreading and scattering.

As already mentioned, a radio signal will often be reflected from the reception point on the Earth into the ionosphere again, reaching the Earth a second time at a still more distant point. As in the case of light waves, the angle of reflection is the same as the angle of incidence, so a wave striking the surface of the Earth at an angle of, say, 15° is reflected upward from the surface at approximately the same angle. Thus, the distance to the second point of reception will be about twice the distance of the first, that is, the distance from the transmitter to point A versus to point B in Fig 18. Under some conditions it is possible for as many as four or five signal hops to occur over a radio path, but no more than two or three hops is the norm. In this way, HF communication can be conducted over thousands of miles.

An important point should be recognized with regard to signal hopping. A significant loss of signal occurs with each hop. The D and E layers of the ionosphere absorb energy from the signals as they pass through, and the ionosphere tends to scatter the radio energy in various directions, rather



than confining it in a tight bundle. The roughness of the Earth's surface also scatters the energy at a reflection point.

Assuming that both waves do reach point B in Fig 18, the low-angle wave will contain more energy at point B. This wave passes through the lower layers just twice, compared to the higher-angle route, which must pass through these layers four times, plus encountering an Earth reflection. Measurements indicate that although there can be great variation in the relative strengths of the two signals—the one-hop signal will generally be from 7 to 10 dB stronger. The nature of the terrain at the mid-path reflection point for the two-hop wave, the angle at which the wave is reflected from the Earth, and the condition of the ionosphere in the vicinity of all the refraction points are the primary factors in determining the signal-strength ratio.

The loss per hop becomes significant at greater distances. It is because of these losses that no more than four or five propagation hops are useful; the received signal becomes too weak to be usable over more hops. Although modes other than signal hopping also account for the propagation of radio waves over thousands of miles, backscatter studies of actual radio propagation have displayed signals with as many as 5 hops. So the hopping mode is one distinct possibility for long-distance communication.

Present propagation theory holds that for communication distances of many thousands of kilometers, signals do not always hop in relatively short increments from ionosphere-to-Earth-to-ionosphere and so forth along the entire path. Instead, the wave is thought to propagate inside the ionosphere throughout some portion of the path length, tending to be ducted in the ionized layer. This theory is supported by the results of propagation studies that show that a medium-angle ray sometimes reaches the Earth at a greater distance from the transmitter than a low-angle ray, as shown in Fig 20. This higher-angle ray, named the *Pedersen ray*, penetrates the layer farther than lower-angle rays. In the less densely ionized upper edge of the layer, the amount of refraction is less, nearly equaling the curvature of the layer itself as it encircles the Earth. This nonhopping theory is further supported by studies of propagation times for signals that travel completely around the world. The time required is significantly less than would be necessary to hop between the Earth and the ionosphere 10 or more times while circling the Earth.

Propagation between two points thousands of kilometers apart may consist of a combination of ducting and hopping. Whatever the exact mechanics of long-distance wave propagation may be, the signal must first enter the ionosphere at some point. The amateur wanting to work great distances should strive to put up antennas that emphasize the lowest possible launch angles, for years of amateur experience have shown this to be a decided advantage under all usual conditions. Despite all the complex factors involved, most long-distance propagation can be seen to follow certain general rules. Thus, much commercial and military point-

to-point communication over long distances employs antennas designed to make maximum use of known radiation angles and layer heights, even on paths where multihop propagation is assumed.

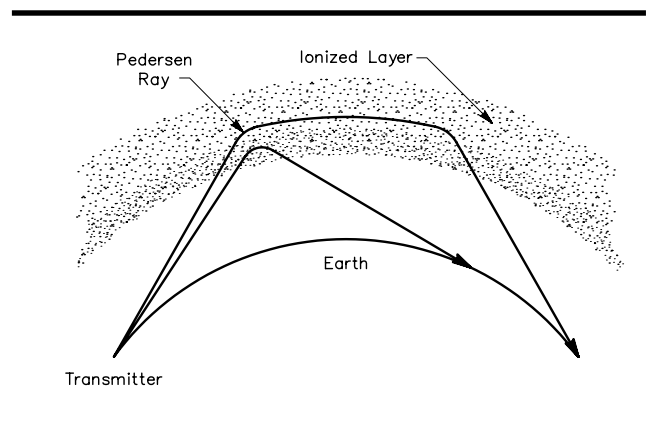
In amateur work we usually try for the lowest practical radiation angle, hoping to keep reflection losses to a minimum. The geometry of propagation by means of the  $F_2$  layer limits our maximum distance along the Earth's surface to about 4000 km (2500 miles) for a single hop. For higher radiation angles, this same distance may require two or more hops (with higher reflection loss). Fewer hops are better, in most cases. If you have a nearby neighbor who consistently outperforms you on the longer paths, a radiation angle difference in his favor is probably the reason.

### Virtual Height and Critical Frequency

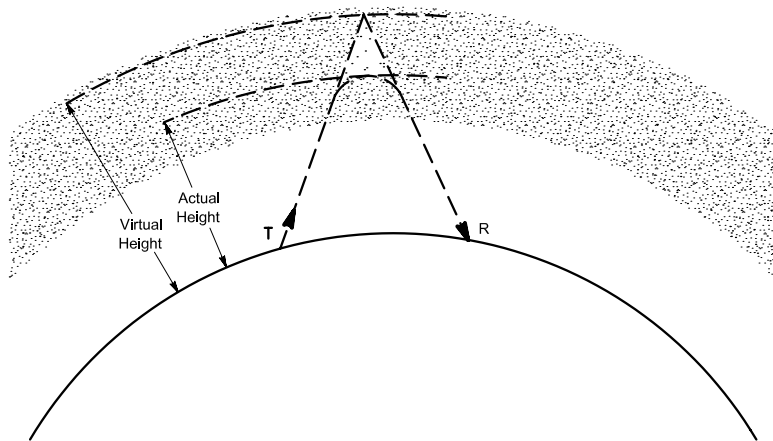
Ionospheric sounding devices have been in service at enough points over the world's surface that a continuous record of ionospheric propagation conditions going back many years is available for current use, or for study. The sounding principle is similar to that of radar, making use of travel time to measure distance. The sounding is made at vertical incidence, to measure the useful heights of the ionospheric layers. This can be done at any one frequency, but the sounding usually is done over a frequency range wider than the expected return-frequency spread, so information related to the maximum usable frequency (MUF) is also obtained.

The distance so measured, called the *virtual height*, is that from which a pure reflection would have the same effect as the rather diffused refraction that actually happens. The method is illustrated in Fig 21. Some time is consumed in the refraction process, so the virtual height is slightly higher than the actual.

The sounding procedure involves pulses of energy at



**Fig 20—Studies have shown that under some conditions, rays entering the layer at intermediate angles will propagate further than those entering at lower angles. The higher-angle wave is known as the Pedersen ray.**



**Fig 21—The virtual height of the refracting layer is measured by sending a wave vertically to the layer and measuring the time it takes to come back to the receiver, as though it were actually reflected rather than refracted. The refraction height is somewhat less because of the time required for the wave to “turn around” in the ionized region.**

progressively higher frequencies, or transmitters with the output frequency swept at many kilohertz per second. As the frequency rises, the returns show an area where the virtual height seems to increase rapidly, and then cease. The highest frequency returned is known as the *vertical incidence critical frequency*. The critical frequency can be used to determine the maximum usable frequency for long-distance communication by way of the layer, at that time. As shown in Fig 18, the amount of bending required decreases as the launch angle decreases. At the lowest practical angle the range for a single hop reaches the 4000-km limit.

### MAXIMUM USABLE FREQUENCY

The vertical incidence critical frequency is the *maximum usable frequency* for local sky-wave communication. It is also useful in the selection of optimum working frequencies and the determination of the maximum usable frequency for distant points at a given time. The abbreviation MUF will be used hereafter.

The critical frequency ranges between about 1 and 4 MHz for the E layer, and between 2 and 13 MHz for the F<sub>2</sub> layer. The lowest figures are for nighttime conditions in the lowest years of the solar cycle. The highest are for the daytime hours in the years of high solar activity. These are average figures. Critical frequencies have reached as high as 20 MHz briefly during exceptionally high solar activity.

The MUF for a 4000-km distance is about 3.5 times the critical frequency existing at the path midpoint. For one-hop signals, if a uniform ionosphere is assumed, the MUF decreases with shorter distances along the path. This is true because the higher-frequency waves must be launched at higher elevation angles for shorter ranges, and at these launch angles they are not bent sufficiently to reach the Earth. Thus, a lower frequency (where more bending occurs) must be used.

Precisely speaking, a maximum usable frequency or MUF is defined for communication between two specific points on the Earth's surface, for the conditions existing at the time, including the minimum elevation angle that the station can launch at the frequency in use. At the same time and for the same conditions, the MUF from either of these two points to a third point may be different. Therefore, the MUF cannot be expressed broadly as a single frequency, even for any given location at a particular time. The ionosphere is never uniform, and in fact at a given time and for a fixed distance, the MUF changes significantly with changes in compass direction for almost any point on the Earth. Under usual conditions, the MUF will always be highest in the direction

toward the Sun—to the east in the morning, to the south at noon (from northern latitudes), and to the west in the afternoon and evening.

For the strongest signals at the greatest distance, especially where the limited power levels of the Amateur Radio Service are concerned, it is important to work fairly near the MUF. It is at these frequencies where signals suffer the least loss. The MUFs can be estimated with sufficient accuracy by using the prediction charts that appear on the ARRL Web site (<http://www.arrl.org/qst/propcharts/>) or by using a computer prediction program. (See section on Propagation Prediction later in this chapter.) MUFs can also be observed, with the use of a continuous coverage communications receiver. Frequencies up to the MUFs are in round-the-clock use today. When you “run out of signals” while tuning upward in frequency from your favorite ham band, you have a pretty good clue as to which band is going to work well, right then. Of course it helps to know the direction to the transmitters whose signals you are hearing. Shortwave broadcasters know what frequencies to use, and you can hear them anywhere, if conditions are good. Time-and-frequency stations are also excellent indicators, since they operate around the clock. See **Table 2**. WWV is also a reliable source of propagation data, hourly, as discussed in more detail later in this chapter.

The value of working near the MUF is two-fold. Under undisturbed conditions, the absorption loss decreases with higher frequency. Perhaps more important, the hop distance is considerably greater as the MUF is approached. A transcontinental contact is much more likely to be made on a single hop on 28 MHz than on 14 MHz, so the higher frequency will give the stronger signal most of the time. The strong-signal reputation of the 28-MHz band is founded on this fact.

**Table 2**  
**Time and Frequency Stations Useful for Propagation Monitoring**

Call	Frequency (MHz)	Location
WWV	2.5, 5, 10, 15, 20	Ft Collins, Colorado
WWVH	Same as WWV but no 20	Kekaha, Kauai, Hawaii
CHU	3.330, 7.335, 14.670	Ottawa, Ontario, Canada
RID	5.004, 10.004, 15.004	Irkutsk, USSR*
RWM	4.996, 9.996, 14.996	Novosibirsk, USSR
VNG	2.5, 5, 8.634, 12.984, 16	Lyndhurst, Australia
BPM	5, 5.43, 9.351, 10, 15	Xiang, China
JJY	2.5, 5, 8, 10, 15	Tokyo, Japan
LOL	5, 10, 15	Buenos Aires, Argentina

\*The call, taken from an international table, may not be that used during actual transmission. Locations and frequencies appear to be as given.

### LOWEST USABLE FREQUENCY

There is also a lower limit to the range of frequencies that provide useful communication between two given points by way of the ionosphere. *Lowest usable frequency* is abbreviated LUF. If it were possible to start near the MUF and work gradually lower in frequency, the signal would decrease in strength and eventually would disappear into the ever-present “background noise.” This happens because the absorption increases at lower frequencies. The frequency nearest the point where reception became unusable would be the LUF. It is not likely that you would want to work at the LUF, although reception could be improved if the station could increase power by a considerable amount, or if larger antennas could be used at both ends of the path.

When solar activity is very high at the peak of a solar cycle, the LUF often rises higher than 14 MHz on the morning US-to-Europe path on 20 meters. Just before sunrise in the US, the 20-meter band will be first to open to Europe, followed shortly by 15 meters, and then 10 meters as the Sun rises further. By mid-morning, however, when 10 and 15 meters are both wide open, 20 meters will become very marginal to Europe, even when both sides are running maximum legal power levels. By contrast, stations on 10 meters can be worked readily with a transmitter power of only 1 or 2 watts, indicating the wide range between the LUF and the MUF.

Frequently, the “window” between the LUF and the MUF for two fixed points is very narrow, and there may be no amateur frequencies available inside the window. On occasion the LUF may be higher than the MUF between two points. This means that, for the highest possible frequency that will propagate through the ionosphere for that

path, the absorption is so great as to make even that frequency unusable. Under these conditions it is impossible to establish amateur sky-wave communication between those two points, no matter what frequency is used. (It would normally be possible, however, to communicate between either point and other points on some frequency under the existing conditions.) Conditions when amateur sky-wave communication is impossible between two fixed points occur commonly for long distances where the total path is in darkness, and for very great distances in the daytime during periods of low solar activity.

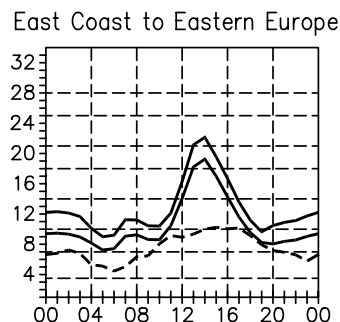
Fig 22 shows a typical propagation prediction from the “How’s DX” column in *QST*. In this instance, the MUF and the LUF lines blurred together at about 10 UTC, meaning that the statistical likelihood of any amateur frequency being open for that particular path at that particular time was not very good. Later on, after about 11 UTC, the gap between the MUF and LUF increased, indicating that the higher bands would be open on that path.

### DISTURBED IONOSPHERIC CONDITIONS

So far, we have discussed the Earth’s ionosphere when conditions at the Sun are undisturbed. There are three general types of major disturbances on the Sun that can affect radio propagation. On the air, you may hear people grouching about *Solar Flares*, *Coronal Holes* or *Sudden Disappearing Filaments*, especially when propagation conditions are not good. Each of these disturbances causes both electromagnetic radiation and ejection of material from the Sun.

#### Solar Flares

Solar flares are cataclysmic eruptions that suddenly release huge amounts of energy, including sustained, high-energy bursts of radiation from VLF to X-ray frequencies



**Fig 22—Propagation prediction chart for East Coast of US to Europe. This appeared in December 1994 *QST*, where an average 2800-MHz (10.7-cm) solar flux of 83 was assumed for the mid-December to mid-January period. On 10% of these days, the highest frequency propagated was predicted at least as high as the uppermost curve (the Highest Possible Frequency, or HPF, approximately 21 MHz), and for 50% of the days as high as the middle curve, the MUF. The broken lines show the Lowest Usable Frequency (LUF) for a 1500-W CW transmitter.**

and vast amounts of solar material. Most solar flares occur around the peak of the 11-year solar cycle.

The first Earthly indication of a huge flare is often a visible brightness near a sunspot group, along with increases in UV, X-ray radiation and VHF radio noise. If the geometry between the Sun and Earth is right, intense X-ray radiation takes eight minutes, traveling the 93 million miles to Earth at the speed of light. The sudden increase in X-ray energy can immediately increase RF absorption in the Earth's lowest ionospheric layers, causing a phenomenon known as a *Sudden Ionospheric Disturbance* (SID).

An SID affects all HF communications on the sunlit side of the Earth. Signals in the 2 to 30-MHz range may disappear entirely, and even most background noise may cease in extreme cases. When you experience a big SID, your first inclination may be to look outside to see if your antenna fell down! SIDs may last up to an hour before ionospheric conditions temporarily return to normal.

Between 45 minutes and 2 hours after an SID begins, particles from the flare begin to arrive. These high-energy particles are mainly protons and they can penetrate the ionosphere at the Earth's magnetic poles, where intense ionization can occur, with attendant absorption of HF signals propagating through the polar regions. This is called a *Polar Cap Absorption* (PCA) event and it may last for several days. A PCA results in spectacular auroral displays at high latitudes.

### Coronal Holes

A second major solar disturbance is a so-called "coronal hole" in the Sun's outer layer (the *corona*). Temperatures in the corona can be more than four million °C over an active sunspot region but more typically are about two million °C. A coronal hole is an area of somewhat lower temperature. Solar-terrestrial scientists have a number of competing theories about how coronal holes are formed.

Matter ejected through this "hole" takes the form of a *plasma*, a highly ionized gas made up of electrons, protons and neutral particles, traveling at speeds up to 300 miles per second. The plasma becomes part of the solar wind and can affect the Earth's magnetic field, but only if the Sun-Earth geometry is right. A plasma has a very interesting and somewhat bizarre ability. It can lock-in the orientation of the magnetic field where it originates and carry it outwards into space. However, unless the locked-in magnetic field orientation is aligned properly with the Earth's magnetic field, even a large plasma mass may not severely disrupt our ionosphere. Presently, we don't have the ability to predict very well when a particular event on the Sun will result in propagation problems, although new satellites now being built should help us in the future.

Statistically, coronal holes tend to occur most often during the declining phase of the 11-year solar cycle and they can last for a number of solar rotations. This means that a coronal hole can be a "recurring coronal hole," disrupting communications for several days about the same time each month for as long as a year, or even more.

### Sudden Disappearing Filaments

A sudden disappearing filament (SDF) is the third major category of solar disturbance that can affect propagation. SDFs take their names from the manner in which they suddenly arch upward from the Sun's surface, spewing huge amounts of matter as plasma out into space in the solar wind. They tend to occur mostly during the rising phase of the 11-year solar cycle.

When the conditions are right, a flare, coronal hole or an SDF can launch a plasma cloud into the solar wind, resulting in an *ionospheric storm* here on Earth. Unlike a hurricane or a winter Nor'easter storm in New England, an ionospheric storm is not something we can see with our eyes or feel on our skins. We can't easily measure things occurring in the ionosphere some 200 miles overhead. However, we can see the indirect effects of an ionospheric storm on magnetic instruments located on the Earth's surface, because disturbances in the ionosphere are closely related to the Earth's magnetic field. The term *Geomagnetic Storm* ("Geo" means "Earth" in Greek) is used almost synonymously with ionospheric storm.

During a geomagnetic storm, we may experience extraordinary radio noise and interference, especially at HF. You may hear solar radio emissions as increases of noise at VHF. A geomagnetic storm generally adds noise and weakens or disrupts ionospheric propagation for several days. Transpolar signals at 14 MHz or higher may be particularly weak, with a peculiar hollow sound or flutter—even more than normal for transpolar signals.

What can we do about the solar disturbances and related disturbed ionospheric propagation on Earth? The truth is that we are powerless faced with the truly awesome forces of solar disturbances like flares, coronal holes or sudden disappearing filaments. Perhaps there is some comfort, however, in understanding what has happened to cause our HF bands to be so poor. And as a definite consolation, conditions on the VHF bands are often exceptionally good just when HF propagation is remarkably poor due to solar disturbances.

### ELEVATION ANGLES FOR HF COMMUNICATION

It was shown in connection with [Fig 18](#) that the distance at which a ray returns to Earth depends on the elevation angle at which it left the Earth (also known by other names: takeoff, launch or wave angle). [Chapter 3](#) in this book deals with the effects of local terrain, describing how the elevation angle of a horizontally polarized antenna is determined mainly by its height above the ground.

Although it is not shown specifically in [Fig 18](#), propagation distance also depends on the layer height at the time, as well as the elevation angle. As you can probably imagine, the layer height is a very complex function of the state of the ionosphere and the Earth's geomagnetic field. There is a large difference in the distance covered in a single hop, depending on the height of the E or the F<sub>2</sub> layer. The

maximum single-hop distance by the E layer is about 2000 km (1250 miles) or about half the maximum distance via the F<sub>2</sub> layer. Practical communicating distances for single-hop E or F layer work at various wave angles are shown in graphic form in **Fig 23**.

Actual communication experience usually does not fit the simple patterns shown in **Fig 18**. Propagation by means of the ionosphere is an enormously complicated business (which makes it all the more intriguing and challenging to radio amateurs, of course), even when the Sun is not in a disturbed state. Until the appearance of sophisticated computer models of the ionosphere, there was little definitive information available to guide the radio amateur in the design of his antenna systems for optimal performance over all portions of the 11-year solar cycle. Elevation angle information that had appeared for many years in *The ARRL Antenna Book* was measured for only one transmitting path, during the lowest portion of Solar Cycle 17 in 1934.

### The IONCAP Computer Propagation Model

Since the 1960s several agencies of the US government have been working on a detailed computer program that models the complex workings of the ionosphere. The program has been dubbed *IONCAP*, short for Ionospheric Communications Analysis and Prediction Program. *IONCAP*

was originally written for a mainframe computer, but later versions have been rewritten to allow them to be run by high-performance personal computers. *IONCAP* incorporates a detailed database covering almost three complete solar cycles. The program allows the operator to specify a wide range of parameters, including detailed antenna models for multiple frequency ranges, noise models tailored to specific local environments (from low-noise rural to noisy residential QTHs), minimum elevation angles suitable for a particular location and antenna system, different months and UTC times, maximum levels of multipath distortion, and finally solar activity levels, to name the most significant of a bewildering array of options.

While *IONCAP* has a well-justified reputation for being very *unfriendly* to use, due to its mainframe, non-interactive background, it is also the one ionospheric model most highly regarded for its accuracy and flexibility, both by amateurs and professionals alike. It is the program used for many years to produce the long-term MUF charts formerly included in the “How’s DX” monthly column of *QST* and now available on the Members Only ARRLWeb page.

*IONCAP* is not well suited for short-term forecasts of propagation conditions based on the latest solar indices received from WWV. It is an excellent tool, however, for long-range, detailed planning of antenna systems and shortwave transmitter installations, such as that for the Voice of America, or for radio amateurs. See the section later in this chapter describing other computer programs that can be used for short-term, interactive propagation predictions.

### IONCAP/VOACAP Parameters

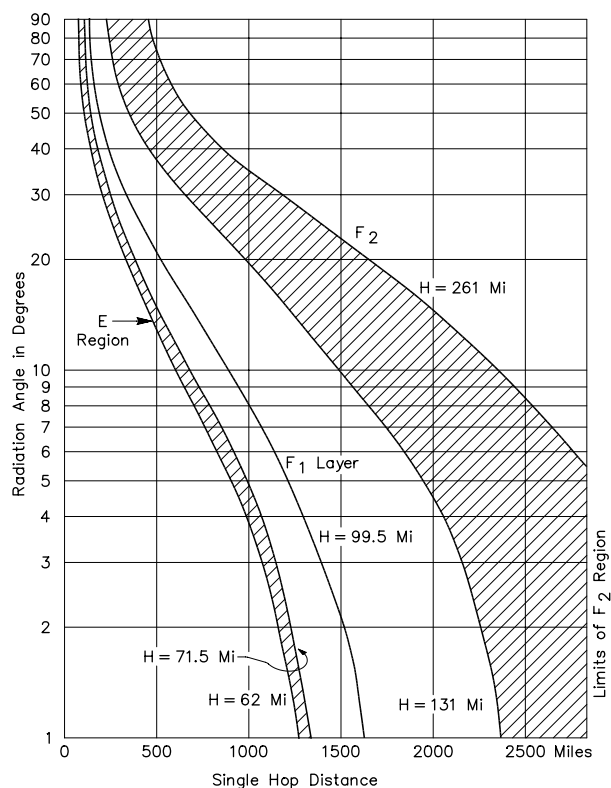
The elevation-angle statistical information contained in this section was compiled from thousands of *VOACAP* runs (an improved version of *IONCAP*). These were done for a number of different transmitting locations throughout the world to important DX locations throughout the world.

Some assumptions were needed for important *VOACAP* parameters. The transmitting and receiving sites were all assumed to be located on flat ground, with “average” ground conductivity and dielectric constant. Each site was assumed to have a clear shot to the horizon, with a minimum elevation angle less than or equal to 1°. Electrical noise at each receiving location was also assumed to be very low.

Transmitting and receiving antennas for the 3.5 to 30-MHz frequency range were specified to be isotropic-type antennas, but with +6 dBi gain, representing a good amateur antenna on each frequency band. These theoretical antennas radiate uniformly from the horizon, up to 90° directly overhead. With response patterns like this, these are obviously not real-world antennas. They do, however, allow the computer program to explore all possible modes and elevation angles.

### Looking at the Elevation-Angle Statistical Data

**Table 3** shows detailed statistical elevation information for the path from Boston, Massachusetts, near ARRL HQ in



**Fig 23—Distance plotted against wave angle (one-hop transmission) for the nominal range of heights for the E and F<sub>2</sub> layers, and for the F<sub>1</sub> layer.**

**Table 3**

**Boston, Massachusetts, to All of Europe**

Elev	80 m	40 m	30 m	20 m	17 m	15 m	12 m	10 m
1	4.1	9.6	4.6	1.7	2.1	4.4	5.5	7.2
2	0.8	2.3	7.2	1.4	2.8	2.8	3.7	5.3
3	0.3	0.7	4.3	3.1	2.4	2.2	4.4	7.9
4	0.5	4.1	8.7	11.6	12.2	9.4	8.1	3.9
5	4.6	4.8	7.5	12.7	14.3	13.1	9.2	11.2
6	7.1	8.9	5.5	9.2	9.6	12.2	9.2	7.2
7	8.5	6.9	7.2	4.6	7.9	7.4	10.0	5.9
8	5.1	7.0	5.4	3.2	5.9	7.4	4.8	6.6
9	3.3	5.6	3.2	3.1	2.1	3.9	8.1	9.2
10	1.0	4.0	7.9	6.3	5.1	3.7	11.1	6.6
11	1.9	3.8	9.7	10.2	7.2	5.4	3.7	7.9
12	5.6	3.4	4.8	8.5	6.9	7.4	4.8	6.6
13	11.0	3.0	2.4	4.1	5.9	4.6	3.3	2.6
14	7.6	4.8	2.0	2.7	3.8	3.9	6.3	5.9
15	5.3	7.9	2.0	1.5	2.4	1.7	1.5	2.0
16	2.8	6.4	3.8	2.9	1.5	1.3	2.6	2.6
17	5.0	3.4	4.5	3.1	1.0	1.5	0.0	0.0
18	4.2	2.0	3.1	3.1	2.0	2.2	1.8	1.3
19	5.7	1.4	1.4	2.3	1.3	0.7	0.0	0.0
20	6.6	1.4	1.2	1.8	1.1	1.3	0.7	0.0
21	4.4	1.4	0.5	0.8	0.7	0.7	0.4	0.0
22	2.3	2.4	1.0	1.1	0.6	1.3	0.7	0.0
23	1.3	1.8	0.1	0.3	0.1	0.0	0.0	0.0
24	0.6	1.0	0.5	0.5	0.4	0.7	0.0	0.0
25	0.3	0.8	0.3	0.1	0.4	0.0	0.0	0.0
26	0.0	0.5	0.7	0.2	0.1	0.4	0.0	0.0
27	0.1	0.1	0.1	0.2	0.1	0.2	0.0	0.0
28	0.0	0.3	0.1	0.2	0.0	0.2	0.0	0.0
29	0.1	0.0	0.2	0.0	0.0	0.0	0.0	0.0
30	0.0	0.1	0.0	0.0	0.0	0.0	0.0	0.0
31	0.0	0.0	0.0	0.0	0.0	0.0	0.0	0.0
32	0.0	0.0	0.1	0.0	0.0	0.0	0.0	0.0
33	0.1	0.0	0.0	0.0	0.0	0.0	0.0	0.0
34	0.0	0.0	0.0	0.0	0.0	0.0	0.0	0.0
35	0.0	0.0	0.0	0.0	0.0	0.0	0.0	0.0

Newington, CT, to all of Europe. The data incorporated into Table 3 covers all HF bands from 80 meters to 10 meters, over all portions of the 11-year solar cycle. The CD-ROM accompanying this book contains more tables such as this for more than 150 transmitting sites around the world. These tables are used by the *YT* program and can also be imported into many programs, such as word processors or spreadsheets. Six important areas throughout the world are covered, one per table: all of Europe (from London, England, to Kiev, Ukraine), the Far East (centered on Japan), South America (Paraguay), Oceania (Melbourne, Australia), Southern Africa (Zambia) and South Asia (New Delhi, India).

You may be surprised to see in Table 3 that angles lower than 6° dominate the possible range of incoming angles for this moderate-distance path from New England to Europe. In fact, roughly 2% of all the times when the 20-meter band is open to Europe, the takeoff angle is as low as 1°. You should recognize that very few real-world 20-meter antennas achieve much gain at such an extremely low angle—unless

they just happen to be mounted about 400 feet high over flat ground or else are located on the top of a tall, steep mountain.

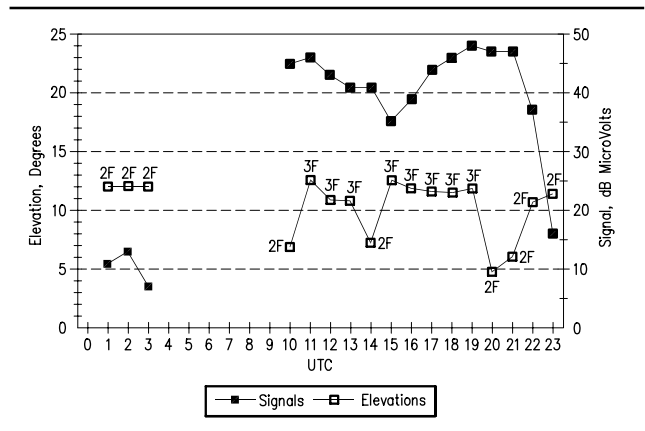
You should always remember that it is the *ionosphere* that controls the elevation angles, *not* the transmitting antenna. The elevation response of a particular antenna only determines how strong or weak a signal is, at whatever angle (or angles) the ionosphere is supporting at that particular instant, for that propagation path and for that frequency.

If only one propagation mode is possible at a particular time, and if the elevation angle for that one mode happens to be 5°, then your antenna will have to work satisfactorily at that very low angle or else you won't be able to communicate. For example, if your low dipole has a gain of -10 dBi at 5°, compared to your friend's Yagi on a mountain top with +10 dBi gain at 5°, then you will be down 20 dB compared to his signal. It's not that the elevation angle is somehow *too low*—the real problem here is that you don't have *enough gain* at that particular angle where the ionosphere is supporting propagation. Many "flatlanders" can vividly recall the times when their mountain-top friends could easily work DX stations, while they couldn't even hear a whisper.

**Looking at the Data—Further Cautions**

A single propagation mode is quite common at the opening and the closing of daytime bands like 15 or 10 meters, when the angle is typically lower than when the band is wide open. The lower-frequency bands tend to support multiple propagation modes simultaneously.

The presence of two distinct peaks in the plot in Fig 24 illustrates the *bi-modality* of the 20-meter path from New England. In fact, this path supports two different multi-hop modes most of the time—a two-hop F<sub>2</sub> and a three-hop F<sub>2</sub>



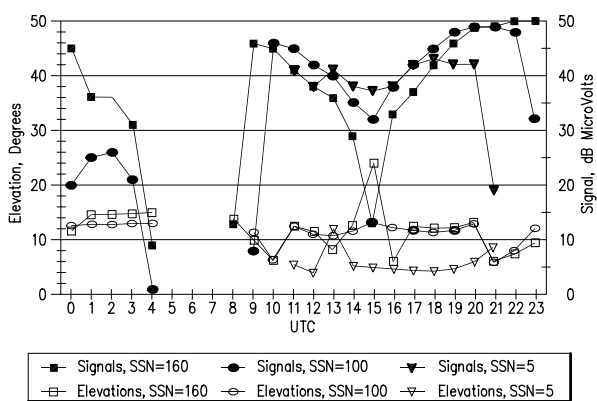
**Fig 24—Overlay of signals and elevation angles, together with hop-mode information. This is for one month, October, at one level of solar activity, SSN=70. The mode of propagation does not closely follow the elevation angle. From 15 to 19 UTC the mode is 3F<sub>2</sub> hops, and the elevation angle is approximately 12°. The same elevation angle is required from 23 to 03 UTC, but here the mode is 2F<sub>2</sub> hops.**

mode. It is tempting to think that two-hop signals always occur at lower elevation launch angles, while three-hop signals require higher elevation angles.

The detailed workings of the ionosphere are enormously complicated. Fig 24 is an example of a combined plot of predicted signal strengths and elevation angles versus UTC time. This is for the month of October, from Newington, CT to London, England, for a period of moderate solar activity, represented by an SSN (12-month Smoothed Sunspot Number) of 70. The dominant F<sub>2</sub>-layer hop mode is placed over the elevation angle for each hour the signal is readable.

From 22 UTC to 03 UTC, the elevation angles are higher than 11° for two F<sub>2</sub>-hops. During much of the morning and early afternoon in Newington (from 11 to 13 UTC, and from 15 to 19 UTC), the angles are also higher than 11°. However, three F<sub>2</sub>-hops are involved during these periods of time. The number of hops is not directly related to the elevation angles needed—changing layer heights account for this.

Note that starting around 15 UTC, the mid-morning 20-meter “slump” (down some 10 dB from peak signal level) is caused by high levels of mainly E-layer absorption when the Sun is high overhead. This condition favors higher elevation angles, since signals launched at lower angles must travel for a longer time through the lossy lower layer. Fig 25 overlays predicted signals and elevation angles for three levels of solar activity in October, again for the Newington-London path. Fig 25 shows the mid-morning slump dramatically when the solar activity is at a high level, represented by SSN = 160. At 15 UTC, the signal level drops 35 dB from peak level, and the elevation angle rises all the way to 24°. By the way, as a percentage of all possible openings, the 24° angle occurs only rarely. It barely shows



**Fig 25—October 20-meter signals and elevation angles for the full range of solar activity, from W1 to England. The elevation angle does not closely follow the level of solar activity. What is important in designing a station capable of covering all levels of solar activity is to have flexibility in antenna elevation pattern response — to cover a wide range of possible angles.**

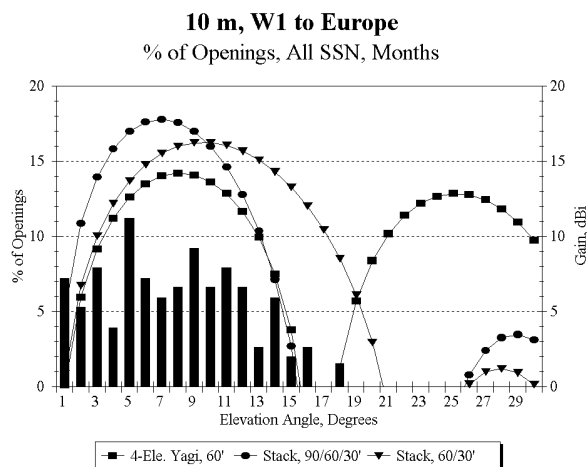
up as a blip in Table 3. Elevation angles are not closely related to the level of solar activity.

IONCAP/VOACAP demonstrates that elevation angles do not follow neat, easily identified patterns, even over a 24-hour period—much less over all portions of the solar cycle. Merely looking at the percentage of all openings versus elevation angle, as shown in Table 3, does not tell the whole story, although it is probably the most statistically valid approach to station design, and possibly the most emotionally satisfying approach too! Neither is the whole story revealed by looking only at a snapshot of elevation angles versus time for one particular month, or for one solar activity level.

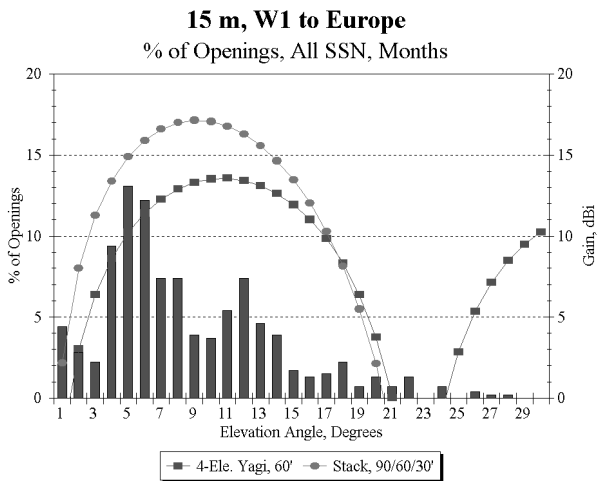
What is important to recognize is that the most effective antenna system will be one that can cover the *full range* of elevation angles, over the whole spectrum of solar activity, even if the actual angle in use at any one moment in time may not be easy to determine. For this particular path, from New England to all of Europe, an ideal antenna would have equal response over the full range of angles from 1° to 28°. Unfortunately, real antennas have a tough time covering such a wide range of elevation angles equally well.

### Antenna Elevation Patterns

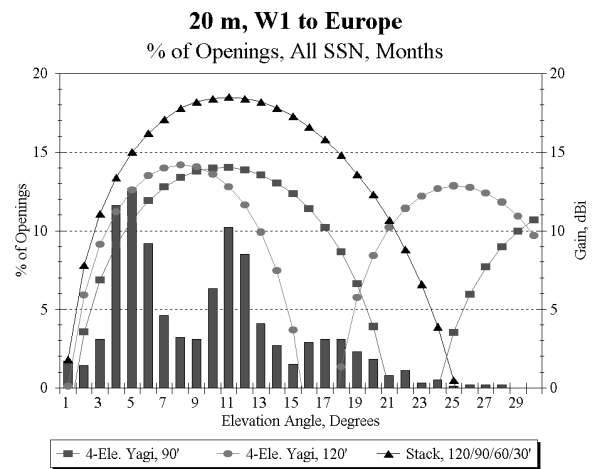
Figs 26, 27, 28, 29 and 30 show overlays of the same sort of elevation angle information listed in Table 3, together with the elevation response patterns for typical antennas for the HF amateur bands 80, 40, 20, 15 and 10 meters. For example, Fig 28 shows an overlay for 20 meters, with three different types of 20-meter antennas. These are a 4-element Yagi at 90 feet, a 4-element Yagi at 120 feet and a large stack of four Yagis located at 120, 90, 60 and 30 feet. Each antenna is assumed to be mounted over flat ground. Placement on a



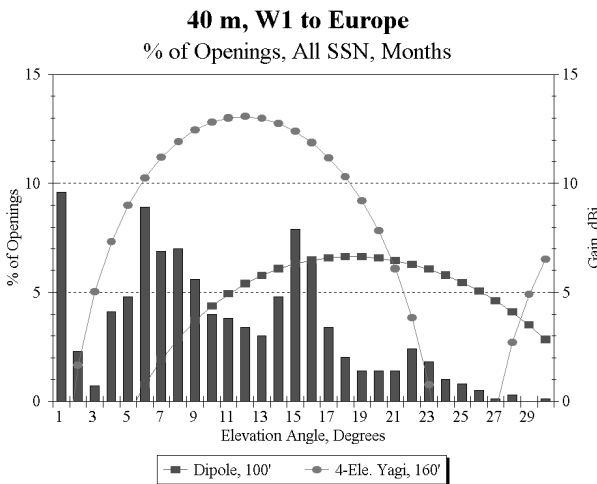
**Fig 26—10-meter graph of the percentage of all openings versus elevation angles, together with overlay of elevation patterns over flat ground for three 10-meter antenna systems. Stacked antennas have wider “footprints” in elevation angle coverage for this example from New England to Europe.**



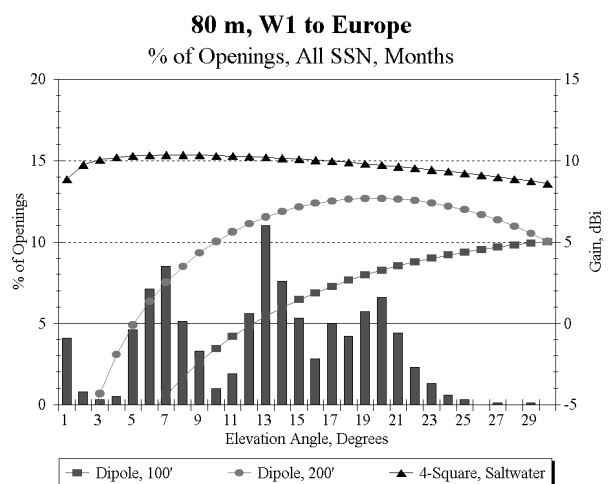
**Fig 27—15-meter graph of the percentage of all openings versus elevation angles, together with overlay of elevation patterns over flat ground for two 15-meter antenna systems. Again, stacked antennas have wider “footprints” in elevation angle coverage for this example from New England to Europe.**



**Fig 28—20-meter graph of the percentage of all openings from New England to Europe versus elevation angles, together with overlay of elevation patterns over flat ground for three 20-meter antenna systems.**



**Fig 29—40-meter graph of the percentage of all openings from New England to Europe versus elevation angles, together with overlays of elevation patterns over flat ground for a 100-foot high dipole and a large 4-element Yagi at 160 feet. Achieving gain at very low elevation angles requires very high heights above ground.**



**Fig 30—80-meter graph of the percentage of all openings from New England to Europe versus elevation angles, together with overlay of elevation patterns over flat ground for dipoles at two different heights. The 200-foot-high dipole clearly covers the necessary elevation angles better than does the 100-foot-high dipole, although a Four Square vertical array located over saltwater is even better for all angles needed.**

hill with a long slope in the direction of interest will lower the required elevation angle by the amount of the hill’s slope. For example, if a 10° launch angle is desired, and the antenna is placed on a hill with a slope of 5°, the antenna itself should be designed for a height that would optimize the response at 15° over flat ground—one wavelength high.

Back at Fig 28, the large stack of four Yagis over flat ground comes closest to being “ideal,” but even this large

array will not work well for that very small percentage of time when the angle needed is higher than about 20°. Some hams might conclude that the tiny percentage of time when the angles are very high doesn’t justify an antenna tailored for that response. However, when that new DX country pops up on a band, or when a rare multiplier shows up in a contest, doesn’t it always seem that the desired signal only comes in at some angle your antenna doesn’t cover well?



What do you do then, if your only antenna happens to be a large stack?

The answer to this, perhaps unique, high-angle problem lies in switching to using only the top antenna in the stack. In this example, the second elevation lobe of the 120-foot high antenna would cover the angles from 20° to 30° well, much better than the stack does. Note that the top antenna by itself would not be ideal for all conditions. It is simply too high much of the time when the elevation angles are higher than about 12°. The experience of many amateurs on the US East Coast with high 20-meter antennas bears this out—they find that 60 to 90-foot high antennas are far more consistent performers into Europe.

### ONE-WAY PROPAGATION

On occasion a signal may be started on the way back toward the Earth by reflection from the F layer, only to come down into the top of the E region and be reflected back up again. This set of conditions is one explanation for the often-reported phenomenon called *one-way skip*. The reverse path may not necessarily have the same multilayer characteristic, and the effect is more often a difference in the signal strengths, rather than a complete lack of signal in one direction. It is important to remember this possibility, when a long-distance test with a new antenna system yields apparently conflicting evidence. Even many tests, on paths of different lengths and headings, may provide data that are difficult to understand. Communication by way of the ionosphere is not always a source of consistent answers to antenna questions!

### SHORT OR LONG PATH?

Propagation between any two points on the Earth's surface is usually by the shortest direct route—the *great-circle path* found by stretching a string tightly between the two points on a globe. If an elastic band going completely around the globe in a straight line is substituted for the string, it will show another great-circle path, going “the long way around.” The long path may serve for communication over the desired circuit when conditions are favorable along the longer route. There may be times when communication is possible over the long path but not possible at all over the short path. Especially if there is knowledge of this potential at both ends of the circuit, long-path communication may work very well. Cooperation is almost essential, because both the aiming of directional antennas and the timing of the attempts must be right for any worthwhile result. The *IONCAP* computations in the preceding tables were made for short-path azimuths only.

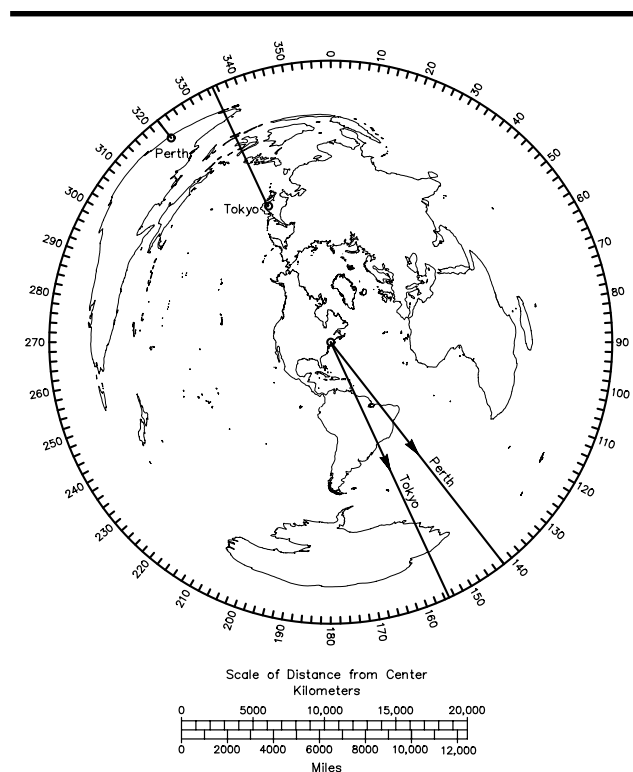
Sunlight is a required element in long-haul communication via the F layer above about 10 MHz. This fact tends to define long-path timing and antenna aiming. Both are essentially the reverse of the “normal” for a given circuit. We know also that salt-water paths work better than overland ones. This can be significant in long-path work.

We can better understand several aspects of long-path propagation if we become accustomed to thinking of the

Earth as a ball. This is easy if we use a globe frequently. A flat map of the world, of the azimuthal-equidistant projection type, is a useful substitute. The ARRL World Map is one, centered on Wichita, Kansas. A similar world map prepared by K5ZI and centered on Newington, Connecticut, is shown in **Fig 31**. These help to clarify paths involving those areas of the world.

### Long-Path Examples

There are numerous long-path routes well known to DX-minded amateurs. Two long paths that work frequently and well when 28 MHz is open from the northeastern US are New England to Perth, Australia, and New England to Tokyo. Although they represent different beam headings and distances, they share some favorable conditions. By long path, Perth is close to halfway around the world; Tokyo is about three-quarters of the way. On 28 MHz, both areas come through in the early daylight hours, Eastern Time, but not necessarily on the same days. Both paths are at their best around the equinoxes. (The sunlight is more uniformly distributed over transequatorial paths at these times.) Probably the factor that most favors both is the nature of the



**Fig 31—K5ZI's computer-generated azimuthal-equidistant projection centered on Newington, Connecticut. (See [Bibliography](#) for ordering information.) The land masses and information showing long paths to Perth and Tokyo have been added. Notice that the paths in both cases lie almost entirely over water, rather than over land masses.**

first part of the trip at the US end. To work Perth by way of long path, northeastern US antennas are aimed southeast, out over salt water for thousands of miles—the best low-loss start a signal could have. It is salt water essentially all the way, and the distance, about 13,000 miles, is not too much greater than the “short” path.

The long path to Japan is more toward the south, but still with no major land mass at the early reflection points. It is much longer, however, than that to Western Australia. Japanese signals are more limited in number on the long path than on the short, and signals on the average somewhat weaker, probably because of the greater distance.

On the short path, an amateur in the Perth area is looking at the worst conditions—away from the ocean, and out across a huge land mass unlikely to provide strong ground reflections. The short paths to both Japan and Western Australia, from most of the eastern half of North America, are hardly favorable. The first hop comes down in various western areas likely to be desert or mountains, or both, and not favored as reflection points.

A word of caution: Don't count on the long-path signals always coming in on the same beam heading. There can be notable differences in the line of propagation via the ionosphere on even relatively short distances. There can be more variations on long path, especially on circuits close to halfway around the world. Remember, for a point exactly halfway around, all directions of the compass represent great-circle paths.

### FADING

When all the variable factors in long-distance communication are taken in account, it is not surprising that signals vary in strength during almost every contact beyond the local range. In VHF communication we can encounter some fading, at distances greater than just to the visible horizon. These are mainly the result of changes in the temperature and moisture content of the air in the first few thousand feet above the ground.

On paths covered by ionospheric modes, the causes of fading are very complex—constantly changing layer height and density, random polarization shift, portions of the signal arriving out of phase, and so on. The energy arriving at the receiving antenna has components that have been acted upon differently by the ionosphere. Often the fading is very different for small changes in frequency. With a signal of a wideband nature, such as high-quality FM, or even double-sideband AM, the sidebands may have different fading rates from each other, or from the carrier. This causes severe distortion, resulting in what is termed *selective fading*. The effects are greatly reduced (but still present to some extent) when single-sideband (SSB) is used. Some immunity from fading during reception (but not to the distortion induced by selective fading) can be had by using two or more receivers on separate antennas, preferably with different polarizations, and combining the receiver outputs in what is known as a *diversity* receiving system.

### OTHER PROPAGATION MODES

In propagation literature there is a tendency to treat the various propagation modes as if they were separate and distinct phenomena. This they may be at times, but often there is a shifting from one to another, or a mixture of two or more kinds of propagation affecting communication at one time. In the upper part of the usual frequency range for F-layer work, for example, there may be enough tropospheric bending at one end (or both ends) to have an appreciable effect on the usable path length. There is the frequent combination of E and F-layer propagation in long-distance work. And in the case of the E layer, there are various causes of ionization that have very different effects on communication. Finally, there are weak-signal variations of both tropospheric and ionospheric modes, lumped under the term “scatter.” We look at these phenomena separately here, but in practice we have to deal with them in combination, more often than not.

#### Sporadic E ( $E_s$ )

First, note that this is *E-subscript-s*, a usefully descriptive term, wrongly written “Es” so often that it is sometimes called “ease,” which is certainly not descriptive. *Sporadic E* is ionization at E-layer height, but of different origin and communication potential from the E layer that affects mainly our lower amateur frequencies.

The formative mechanism for sporadic E is believed to be wind shear. This explains ambient ionization being distributed and compressed into a ledge of high density, without the need for production of extra ionization. Neutral winds of high velocity, flowing in opposite directions at slightly different altitudes, produce shears. In the presence of the Earth's magnetic field, the ions are collected at a particular altitude, forming a thin, overdense layer. Data from rockets entering  $E_s$  regions confirm the electron density, wind velocities and height parameters.

The ionization is formed in clouds of high density, lasting only a few hours at a time and distributed randomly. They vary in density and, in the middle latitudes in the Northern Hemisphere, move rapidly from southeast to northwest. Although  $E_s$  can develop at any time, it is most prevalent in the Northern Hemisphere between May and August, with a minor season about half as long beginning in December (the summer and winter solstices). The seasons and distribution in the Southern Hemisphere are not so well known. Australia and New Zealand seem to have conditions much like those in the US, but with the length of the seasons reversed, of course. Much of what is known about  $E_s$  came as the result of amateur pioneering in the VHF range.

Correlation of  $E_s$  openings with observed natural phenomena, including sunspot activity, is not readily apparent, although there is a meteorological tie-in with high-altitude winds. There is also a form of  $E_s$ , mainly in the northern part of the north temperate zone, that is associated with auroral phenomena.

At the peak of the long  $E_s$  season, most commonly in

late June and early July, ionization becomes extremely dense and widespread. This extends the usable range from the more common “single-hop” maximum of about 1400 miles to “double-hop” distances, mostly 1400 to 2500 miles. With 50-MHz techniques and interest improving in recent years, it has been shown that distances considerably beyond 2500 miles can be covered. There is also an  $E_s$  “link-up” possibility with other modes, believed to be involved in some 50-MHz work between antipodal points, or even long-path communication beyond 12,500 miles.

The MUF for  $E_s$  is not known precisely. It was long thought to be around 100 MHz, but in the last 25 years or so there have been thousands of 144-MHz contacts during the summer  $E_s$  season. Presumably, the possibility also exists at 222 MHz. The skip distance at 144 MHz does average much longer than at 50 MHz, and the openings are usually brief and extremely variable.

The terms “single” and “double” hop may not be accurate technically, since it is likely that cloud-to-cloud paths are involved. There may also be “no-hop”  $E_s$ . At times the very high ionization density produces critical frequencies up to the 50-MHz region, with no skip distance at all. It is often said that the  $E_s$  mode is a great equalizer. With the reflecting region practically overhead, even a simple dipole close to the ground may do as well over a few hundred miles as a large stacked antenna array designed for low-angle radiation. It’s a great mode for low power and simple antennas on 28 and 50 MHz.

### Scatter Modes

The term “skip zone” (where no signals are heard) should not be taken too literally. Two stations communicating over a single ionospheric hop can be heard to some degree at almost any point along the way, unless they are running low power and using simple antennas. Some of the wave energy is *scattered* in all directions, including back to the starting point and farther. The wave energy of VHF stations is not gone after it reaches the radio horizon, described early in this chapter. It is scattered, but it can be heard to some degree for hundreds of miles. Everything on Earth, and in the regions of space up to at least 100 miles, is a potential scattering agent.

*Tropospheric scatter* is always with us. Its effects are often hidden, masked by more effective propagation modes on the lower frequencies. But beginning in the VHF range, scatter from the lower atmosphere extends the reliable range markedly if we make use of it. Called “tropo scatter,” this is what produces that nearly flat portion of the curves given in an earlier section on reliable VHF coverage. We are not out of business at somewhere between 50 and 100 miles, on the VHF and even UHF bands, especially if we don’t mind weak signals and something less than 99% reliability. As long ago as the early 1950s, VHF enthusiasts found that VHF contests could be won with high power, big antennas and a good ear for signals deep in the noise. They still can.

*Ionospheric scatter* works much the same as the tropo

version, except that the scattering medium is the E region of the ionosphere, with some help from the D and F layers too. Ionospheric scatter is useful mainly above the MUF, so its useful frequency range depends on geography, time of day, season, and the state of the Sun. With near maximum legal power, good antennas and quiet locations, ionospheric scatter can fill in the skip zone with marginally readable signals scattered from ionized trails of meteors, small areas of random ionization, cosmic dust, satellites and whatever may come into the antenna patterns at 50 to 150 miles or so above the Earth. It’s mostly an E-layer business, so it works all E-layer distances. Good antennas and keen ears help.

*Backscatter* is a sort of ionospheric radar. Because it involves mainly scattering from the Earth at the point where the strong ionospherically propagated signal comes down, it is a part of long-distance radar techniques. It is also a great “filler-inner” of the skip zone, particularly in work near the MUF, where propagation is best. It was proved by amateurs using sounding techniques that you can tell to what part of the world a band is usable (single-hop F) by probing the backscatter with a directive antenna, even when the Earth contact point is open ocean. In fact, that’s where the mode is at its best.

Backscatter is very useful on 28 MHz, particularly when that band seems dead simply because nobody is active in the right places. The mode keeps the 10-meter band lively in the low years of the solar cycle, thanks to the never-say-die attitude of some users. The mode is also an invaluable tool of 50-MHz DX aspirants, in the high years of the sunspot cycle, for the same reasons. On a high-MUF morning, hundreds of 6-meter beams may zero in on a hot spot somewhere in the Caribbean or South Atlantic, where there is no land, let alone other 6-meter stations—keeping in contact while they wait for the band to open to a place where there is somebody.

*Sidescatter* is similar to backscatter, except the ground scatter zone is merely somewhat off the direct line between participants. A typical example, often observed during the lowest years of the solar cycle, is communication on 28 MHz between the eastern US (and adjacent areas of Canada) and much of the European continent. Often, this may start as “backscatter chatter” between Europeans whose antennas are turned toward the Azores. Then suddenly the North Americans join the fun, perhaps for only a few minutes, but sometimes much longer, with beams also pointed toward the Azores. Duration of the game can be extended, at times, by careful reorientation of antennas at both ends, as with backscatter. The secret, of course, is to keep hitting the highest-MUF area of the ionosphere and the most favorable ground-reflection points.

The favorable route is usually, but not always, south of the great-circle heading (for stations in the Northern Hemisphere). There can also be sidescatter from the auroral regions. Sidescatter signals are stronger than backscatter signals using the same general area of ground scattering.

Sidescatter signals have been observed frequently on

the 14-MHz band, and can take place on any band where there is a large window between the MUF and the LUF. For sidescatter communications to occur, the thing to look for is a common area to which the band is open from both ends of the path (the Azores, in the above example), when there is no direct-path opening. It helps if the common area is in the open ocean, where there is less scattering loss than over land.

*Transequatorial scatter* (TE) was an amateur 50-MHz discovery in the years 1946-1947. It was turned up almost simultaneously on three separate north-south paths, by amateurs of all continents. These amateurs tried to communicate at 50 MHz, even though the predicted MUF was around 40 MHz for the favorable daylight hours. The first success came at night, when the MUF was thought to be even lower. A remarkable research program inaugurated by amateurs in Europe, Cyprus, Zimbabwe and South Africa eventually provided technically sound theories to explain the then-unknown mode.

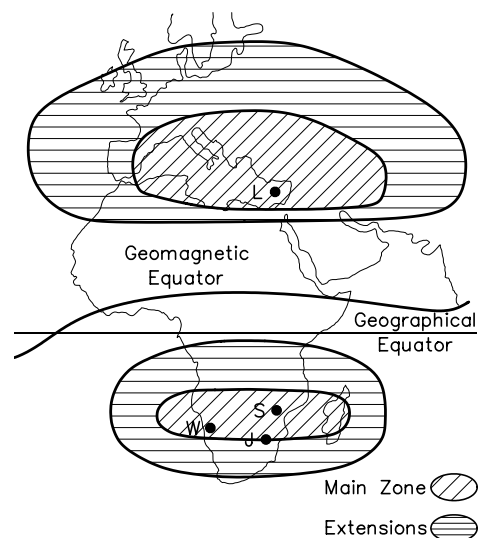
It has been known for years that the MUF is higher and less seasonally variable on transequatorial circuits, but the full extent of the difference was not learned until amateur work brought it to light. Briefly, the ionosphere over equatorial regions is higher, thicker and more dense than elsewhere. Because of its more constant exposure to solar radiation, the equatorial belt has high nighttime-MUF possibilities. It is now known that the TE mode can often work marginally at 144 MHz, and even at 432 MHz on occasion. The potential MUF varies with solar activity, but not to the extent that conventional F-layer propagation does. It is a late-in-the-day mode, taking over about when normal F-layer propagation goes out.

The TE range is usually within about 4000 km (2500 miles) either side of the geomagnetic equator. The Earth's magnetic axis is tilted with respect to the geographical axis, so the TE belt appears as a curving band on conventional flat maps of the world. See **Fig 32**. As a result, TE has a different latitude coverage in the Americas from that shown in the drawing. The TE belt just reaches into the southern US. Stations in Puerto Rico, Mexico and even the northern parts of South America encounter the mode more often than those in favorable US areas. It is no accident that TE was discovered as a result of 50-MHz work in Mexico City and Buenos Aires.

Within its optimum regions of the world, the TE mode extends the usefulness of the 50-MHz band far beyond that of conventional F-layer propagation, since the practical TE MUF runs around 1.5 times that of normal  $F_2$ . Both its seasonal and diurnal characteristics are extensions of what is considered normal for 50-MHz propagation. In that part of the Americas south of about 20° North latitude, the existence of TE affects the whole character of band usage, especially in years of high solar activity.

### Auroral Propagation

Sudden bursts of solar activity are accompanied by the ejection of charged particles from the Sun. These particles



**Fig 32—Main and occasional zones of transequatorial 50-MHz propagation show Limassol, Cyprus, and Salisbury, Zimbabwe, to be almost ideally positioned with respect to the curving geomagnetic equator. Windhoek, Namibia, is also in a favorable spot; Johannesburg somewhat less so.**

travel in various directions, and some may enter the Earth's atmosphere, usually 24 to 36 hours after the event. Here they may react with the Earth's magnetic field to produce a visible or radio *aurora*, visible if their time of entry is after dark. Some information on major solar outbursts is obtainable from WWV propagation bulletins, discussed later in this chapter. (From WWV information, the possibility of auroral activity can be known in advance.)

The visible aurora is, in effect, fluorescence at E-layer height—a curtain of ions capable of refracting radio waves in the frequency range above about 20 MHz. D-region absorption increases on lower frequencies during auroras. The exact frequency ranges depend on many factors: time, season, position with relation to the Earth's auroral regions, and the level of solar activity at the time, to name a few.

The auroral effect on VHF waves is another amateur discovery, this one dating back to the 1930s. The discovery came coincidentally with improved transmitting and receiving techniques. The returning signal is diffused in frequency by the diversity of the auroral curtain as a refracting (scattering) medium. The result is a modulation of a CW signal, from just a slight burbling sound to what is best described as a "keyed roar." Before SSB took over in VHF work, voice was all but useless for auroral paths. A sideband signal suffers, too, but its narrower bandwidth helps to retain some degree of understandability. Distortion induced by a given set of auroral conditions increases with the frequency in use. 50-MHz signals are much more intelligible than those on 144 MHz on the same path at the same time. On 144 MHz, CW is almost mandatory for effective auroral communication.

The number of auroras that can be expected per year varies with the geomagnetic latitude. Drawn with respect to the Earth's magnetic poles instead of the geographical ones, these latitude lines in the US tilt upward to the northwest. For example, Portland, Oregon, is 2° farther north (geographic latitude) than Portland, Maine. The Maine city's geomagnetic latitude line crosses the Canadian border before it gets as far west as its Oregon namesake. In terms of auroras intense enough to produce VHF propagation results, Portland, Maine, is likely to see about 10 times as many per year. Oregon's auroral prospects are more like those of southern New Jersey or central Pennsylvania.

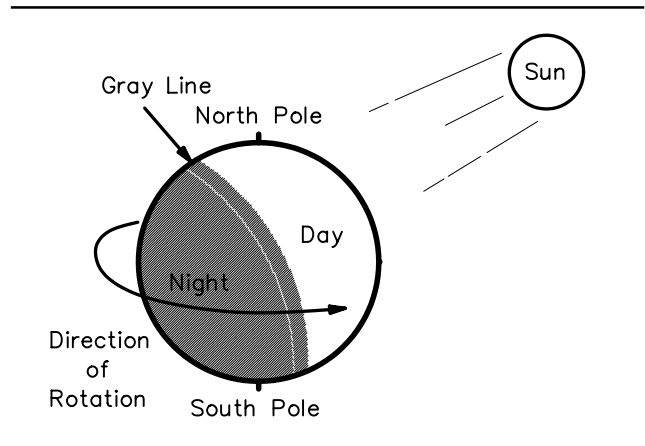
The antenna requirements for auroral work are mixed. High gain helps, but the area of the aurora yielding the best returns sometimes varies rapidly; sharp directivity can be a disadvantage. So could a very low radiation angle, or a beam pattern very sharp in the vertical plane. Experience indicates that few amateur antennas are sharp enough in either plane to present a real handicap. The beam heading for maximum signal can change, however, so a bit of scanning in azimuth may turn up some interesting results. A very large array, such as is commonly used for moonbounce (with azimuth-elevation control), should be worthwhile.

The incidence of auroras, their average intensity, and their geographical distribution as to visual sightings and VHF propagation effects all vary to some extent with solar activity. There is some indication that the peak period for auroras lags the sunspot-cycle peak by a year or two. Like sporadic E, an unusual auroral opening can come at any season. There is a marked diurnal swing in the number of auroras. Favored times are late afternoon and early evening, late evening through early morning, and early afternoon, in about that order. Major auroras often start in early afternoon and carry through to early morning the next day.

### GRAY-LINE PROPAGATION

The *gray line*, sometimes called the *twilight zone*, is a band around the Earth between the Sunlit portion and darkness. Astronomers call this the *terminator*. The terminator is a somewhat diffused region because the Earth's atmosphere tends to scatter the light into the darkness. **Fig 33** illustrates the gray line. Notice that on one side of the Earth, the gray line is coming into daylight (sunrise), and on the other side it is coming into darkness (sunset).

Propagation along the gray line is very efficient, so greater distances can be covered than might be expected for the frequency in use. One major reason for this is that the D



**Fig 33**—The gray line or terminator is a transition region between daylight and darkness. One side of the Earth is coming into sunrise, and the other is just past sunset.

layer, which absorbs HF signals, disappears rapidly on the sunset side of the gray line, and has not yet built up on the sunrise side.

The gray line runs generally north and south, but varies as much as 23° either side of the north-south line. This variation is caused by the tilt of the Earth's axis relative to its orbital plane around the Sun. The gray line will be exactly north and south at the equinoxes (March 21 and September 21). On the first day of Northern Hemisphere summer, June 21, it is tilted to the maximum of 23° one way, and on December 21, the first day of winter, it is tilted 23° the other way.

To an observer on the Earth, the direction of the terminator is always at right angles to the direction of the Sun at sunrise or sunset. It is important to note that, except at the equinoxes, the gray-line direction will be different at sunrise from that at sunset. This means you can work different areas of the world in the evening than you worked in the morning.

It isn't necessary to be located inside the twilight zone in order to take advantage of gray-line propagation. The effects can be used to advantage before sunrise and after sunset. This is because the Sun "rises" earlier and "sets" later on the ionospheric layers than it does on the Earth below.

# What HF Bands Are Open—Where and When?

The CD-ROM included at the back of this book includes summary propagation predictions for more than 150 transmitting locations around the world. This propagation data was calculated using *CapMAN*, a variety of the mainframe propagation program *IONCAP*. The predictions were done for default antennas and powers that are representative of a “big gun” station. Of course, not everyone has a big-gun station in his/her backyard, but this represents what the ultimate possibilities are, statistically speaking. After all, if the bands aren’t open for the big guns, they are unlikely to be open for the “little pistols” too.

Let’s see how propagation is affected if the smoothed sunspot number is 0 (corresponding to a smoothed solar flux of about 65), which is classified as a “Very Low” level of solar activity. And we’ll examine the situation for a sunspot number of 100 (a smoothed solar flux of 150), which is typical of a “Very High” portion of the solar cycle.

**Tables 4 and 5** are summary tables showing the predicted signal levels (in S units) from Boston, Massachusetts, to the rest of the world for the month of January. The Boston transmitting site is representative of the entire New England area of the USA. The target geographic receiving regions for the major HF bands from 80 through 10 meters are tabulated versus UTC (Universal Coordinated Time) in hours. Table 4 represents a Very Low level of solar activity, while Table 5 is for a Very High level of solar activity.

The receiving geographic regions for each frequency band are abbreviated: EU (for all of Europe), FE (for Far East, centered on Japan), SA (South America, centered on Paraguay), AF (all of Africa), AS (south Asia, centered on India), OC (Oceania, centered on Sydney, Australia) and NA (North America, all across the USA). For example, **Table 4** shows that in January during a period of Very Low solar activity, 15 meters is open to somewhere in Europe from Boston for only 4 hours, from 13 to 16 UTC, with a peak signal level between S4 and S7. Now look at **Table 5**, where 15 meters is predicted to be open to Europe during a period of Very High solar activity for 7 hours, from 12 to 18 UTC, with peak signals ranging from S9 to S9+.

Both **Tables 4 and 5** represent “snapshots” of predicted signal levels to generalized receiving locations—that is, they are computed for a particular month, from a particular transmitting location, and for a particular level of solar activity. These tables provide summary information that is particularly valuable for someone planning for an operating event such as a DXpedition or a contest.

A newcomer to the HF bands could easily be overwhelmed with the sheer amount of data available in the summary tables located on the CD-ROM included with this book. (The CD-ROM-version of *The ARRL Antenna Book* itself contains [even more detailed data](#) for the truly dedicated DXer!)

So here’s a long-term, “big-picture” view of HF propagation that might help answer some common questions. For example, what month really is the best for working DX

around the clock? Or what level of solar activity is necessary to provide an opening between your QTH and somewhere in the South Pacific?

**Table 6** is a table showing the number of hours in a day during each month when each major HF band is open to the same receiving town in **Tables 4 and 5**. The listing is for New England, for three levels of solar activity: Very Low, Medium and Very High. The number of hours are separated in **Table 6** by slashes.

Let’s continue the example cited previously for New England to Europe on 15 meters. The entry for October shows “7/11/17,” meaning that for a Very Low level of solar activity, 15 meters is open for 7 hours; for a Medium level, it is open for 11 hours and for a Very High level of solar activity it is open for 17 hours a day.

Even for a Very Low level of solar activity, the month with the most hours available per day from Boston to somewhere in Europe is October, with 7 hours, followed by the next largest month of March, with 6 hours. For a Very High level of solar activity, however, the 15-meter band is open to Europe for 18 hours in April, followed by 17 hours availability in September and October. Arguably, the CQ World Wide Contest Committee picked the very best month for higher-frequency propagation when they chose October for the Phone portion of that contest.

You can easily see that even at a Very High level of solar activity, the summer months are not very good to work DX, particularly on east-west paths. For example, the 10-meter band is very rarely open from New England to Europe after the month of April, even when solar activity is at the highest levels possible. Things pick up after September, even for a Medium level of solar activity. Again, October looks like the most fruitful month in terms of the number of hours 10 meters is open to Europe under all levels of solar conditions.

Ten meters is open more regularly on north-south paths, such as from New England to South America or to southern Africa. It is open as much as 10 hours a day during March and October to deep South America, and 7 hours a day in October to Africa—even during the lowest parts of the solar cycle. (Together with the sporadic-E propagation that 10 meters enjoys during the summer, this band can often be a lot of fun even during the sunspot doldrums. You just have to *be operating* on the band, rather than avoiding it because you know the sunspots are “spotty!”)

Now, look at the 20-meter band in **Table 6**. From New England, twenty is open to somewhere in South America for 24 hours a day, no matter the level of solar activity. Note that **Table 6** doesn’t predict the level of signals available; it just shows that the band is open with a signal strength greater than 0 on the S meter. Look back at **Table 4** for the predicted signal strengths in January at a Very Low level of solar activity. There, you can see that the signal strength from New England into deep South America is always S8 or greater for a big gun station. A lot of the time during the

**Table 4**

**Printout of summary propagation table for Boston to the rest of the world, for a Very Low level of solar activity in the month of January. The abbreviations for the target geographic areas are: EU = Europe, FE = Far East, SA = South America, AF = Africa, AS = south Asia, OC = Oceania, and NA = North America.**

Jan., MA (Boston), for SSN = Very Low, Sigs in S-Units. By N6BV, ARRL.

UTC	80 Meters							40 Meters							20 Meters							15 Meters							10 Meters							UTC
	EU	FE	SA	AF	AS	OC	NA	EU	FE	SA	AF	AS	OC	NA	EU	FE	SA	AF	AS	OC	NA	EU	FE	SA	AF	AS	OC	NA	EU	FE	SA	AF	AS	OC	NA	
0	9	-	9+	9	9	-	9+	9	8	9+	9+	9	2	9+	-	8	9+	7	4	8	9+	-	-	-	-	-	1	-	-	-	-	-	2	0		
1	9	-	9+	9	9	-	9+	9	6	9+	9+	9+	6	9+	-	4	9	4	2	6	9+	-	-	-	-	-	1	-	-	-	-	-	2	1		
2	9	-	9+	9+	8	1	9+	9	6	9+	9+	9	8	9+	-	1	8	1	2	3	9+	-	-	-	-	-	1	-	-	-	-	-	2	2		
3	9	-	9+	9+	8	6	9+	9	6	9+	9+	9	8	9+	-	-	8	2	2	-	9+	-	-	-	-	-	1	-	-	-	-	-	2	3		
4	9	-	9+	9+	1	8	9+	9	8	9+	9+	9	9	9+	-	1	8	7	2	-	9+	-	-	-	-	-	1	-	-	-	-	-	2	4		
5	9	-	9+	9+	-	9	9+	9	8	9+	9+	8	9	9+	-	1	9	8	2	-	9	-	-	-	-	-	1	-	-	-	-	-	2	5		
6	9+	-	9+	9+	-	9	9+	7	8	9+	9+	8	9	9+	-	1	9+	8	-	-	9	-	-	-	-	-	1	-	-	-	-	-	2	6		
7	9	7	9+	9	-	9	9+	7	8	9+	9	8	9	9+	-	1	9+	1	-	1	8	-	-	-	-	-	1	-	-	-	-	-	2	7		
8	9	8	9+	9	-	9	9+	8	9	9+	9	8	9+	9+	-	1	9+	-	-	5	9	-	-	-	-	-	1	-	-	-	-	-	2	8		
9	8	8	9+	7	6	9	9+	8	9	9+	9	9	9+	9+	-	-	9	1	-	7	9	-	-	-	-	-	1	-	-	-	-	-	2	9		
10	5	8	9+	4	6	9	9+	9	9	9+	9	9	9+	9+	-	3	9	5	-	6	9	-	-	-	-	-	1	-	-	-	-	-	2	10		
11	3	8	9+	-	5	9	9+	8	9	9+	7	9	9+	9+	5	-	9+	9	5	1*	8	-	-	-	-	-	1	-	-	-	-	-	2	11		
12	1	8	9	-	4	9	9+	7	9	9+	4	8	9	9+	9	5	9+	9+	9	2*	8	-	-	5	6	-	1	-	-	-	-	-	2	12		
13	-	6	1	-	-	7	9+	6	8	9+	1	8	9	9+	9+	9	9+	9	7	8	4	-	9+	9	7	-	1	-	-	-	-	-	2	13		
14	-	-	-	-	-	1	9+	5	7	8	-	8	8	9+	9+	9	9+	9	9	9	9+	7	2*	9+	9	9	-	8	-	-	5	-	-	1	14	
15	-	-	-	-	-	-	9+	4	6	5	-	6	7	9+	9+	9	9+	9	9	9	9+	7	5	9+	9	2	2	5	-	-	5	-	-	-	15	
16	-	-	-	-	-	-	9+	5	6	4	2	5	4	9+	9+	8	9+	9+	9	9	9+	5	1	9+	8	2*	2	9	-	-	5	-	-	1	16	
17	-	-	-	-	-	-	9+	6	5	5	5	6	1	9+	9+	5	9+	9+	3	9	9	-	-	9+	9	-	3	9+	-	-	5	-	-	1	17	
18	1	-	-	-	-	-	9+	8	6	6	7	6	-	9+	9+	6	9+	9+	4	9	9+	-	-	9+	9	-	7	9+	-	-	5	-	-	1	18	
19	3	-	-	2	-	-	9+	9	7	8	8	8	-	9+	6	6	9+	9+	6	9	9+	-	-	9+	9	-	9	9+	-	-	2	-	-	1	19	
20	5	-	7	5	-	-	9+	9	8	9+	9	8	4	9+	1	7	9+	9+	8	9	9+	-	-	9+	4	-	9	9	-	-	-	-	1	20		
21	8	3	9	8	6	-	9+	9	8	9+	9+	9	7	9+	-	8	9+	8	8	9	9+	-	-	9+	-	-	9	6	-	-	-	-	1	21		
22	9	3	9+	9	8	-	9+	9	8	9+	9+	9	5	9+	-	9+	9+	9	8	9	9+	-	-	9	-	-	7	1	-	-	-	-	1	22		
23	9	2	9+	9	9	-	9+	9	8	9+	9+	9	4	9+	-	9+	9+	9	5	9	9+	-	1	6	-	-	2	3	-	-	-	-	2	23		

**Table 5**

**Printout of summary propagation table for Boston to the rest of the world, for a Very High level of solar activity in the month of January.**

Jan., MA (Boston), for SSN = Very High, Sigs in S-Units. By N6BV, ARRL.

UTC	80 Meters							40 Meters							20 Meters							15 Meters							10 Meters							UTC
	EU	FE	SA	AF	AS	OC	NA	EU	FE	SA	AF	AS	OC	NA	EU	FE	SA	AF	AS	OC	NA	EU	FE	SA	AF	AS	OC	NA	EU	FE	SA	AF	AS	OC	NA	
0	9+	-	9+	9+	8	-	9+	9+	5	9+	9+	9	-	9+	1	9+	9+	9+	9+	9	9+	-	9	9+	2	2	9+	9+	-	1	8	-	-	8	9+	0
1	9+	-	9+	9+	8	-	9+	9+	4	9+	9+	9	2	9+	1	9	9+	8	9+	9+	9+	-	3	9	-	7	9+	9	-	-	-	-	4	2	1	
2	9+	-	9+	9+	7	-	9+	9+	4	9+	9+	9	7	9+	1	9	9+	8	9	9+	9+	-	-	3	-	-	7	9	-	-	-	-	-	2	2	
3	9+	-	9+	9+	1	2	9+	9+	4	9+	9+	9	9	9+	-	7	9+	7	8	9+	9	-	-	-	-	-	-	-	-	-	-	-	-	2	3	
4	9+	-	9+	9+	-	7	9+	9+	5	9+	9+	8	9	9+	-	5	9	9	9	9	9+	-	-	1	-	-	-	-	-	-	-	-	-	2	4	
5	9+	-	9+	9+	-	8	9+	9+	6	9+	9+	7	9	9+	-	5	9+	9	9	5	9+	-	-	-	-	-	-	-	-	-	-	-	-	2	5	
6	9+	-	9+	9+	-	8	9+	9+	7	9+	9+	7	9	9+	-	8	9+	8	9	5	9+	-	-	-	-	-	-	-	-	-	-	-	-	2	6	
7	9+	-	9+	9+	-	8	9+	9	8	9+	9+	7	9+	9+	-	9	9+	-	7	9	9+	-	-	1	-	-	-	-	-	-	-	-	-	2	7	
8	9	7	9+	9	-	8	9+	9	8	9+	9+	8	9+	9+	-	9	9+	-	4	9	9+	-	-	1	-	-	-	2	-	-	-	-	-	2	8	
9	8	7	9+	7	-	8	9+	9	9	9+	9	8	9+	9+	-	6	9+	-	1	9+	9+	-	-	-	-	-	1	-	-	-	-	-	2	9		
10	5	8	9+	2	3	8	9+	9	9	9+	8	8	9	9+	4	-	9+	9+	1	5	9	-	-	-	-	-	-	-	-	-	-	-	2	10		
11	1	8	9+	-	4	9	9+	8	9	9+	5	8	9	9+	9+	4*	9+	9+	7	-	8	-	-	9	9	-	-	-	-	-	-	-	2	11		
12	-	7	8	-	1	9	9+	6	9	9+	1	8	9	9+	9+	9	9+	9	9	1*	9+	9	8*	9+	9+	9	5*	-	-	2*	9	9	1	1*	2	12
13	-	-	-	-	-	2	9+	4	8	8	-	7	9	9+	9+	9	9+	9	9	9+	9+	9+	7	9+	9+	9+	3*	9	9	5*	9+	9+	6*	2	13	
14	-	-	-	-	-	-	9+	2	7	4	-	5	8	9+	9+	9	9+	8	9	9	9+	9+	9	9+	9+	9	9	9+	9	6*	9+	9+	1*	1	14	
15	-	-	-	-	-	-	9	1	5	-	-	4	5	9+	9+	9	9+	9	9	9	9+	9+	9+	9+	9+	9	9+	9	9	5	9+	9+	6	6	8	15
16	-	-	-	-	-	-	8	3	4	-	-	3	1	9+	9+	8	9	9	9	9	9+	9+	9+	9+	9	9+	9	9	9	8	9+	9+	-	8	9	16
17	-	-	-	-	-	-	8	5	3	-	2	4	-	9+	9+	8	9+	9	9	9	9+	9+	9	9+	1*	9+	9+	-	8	9	9+	-	8	9+	17	
18	-	-	-	-	-	-	9	7	4	2	5	5	-	9+	9+	9	9+	9	9	9	9+	9+	9	9+	1	9+	9+	-	7	9+	9+	-	9+	9+	18	
19	1	-	-	1	-	-	9+	8	5	6	8	7	-	9+	9+	9	9+	9	9	9	9+	-	9+	9+	2	9	9+	-	6	9+	9+	-	9+	9+	19	
20	4	-	2	5	-	-	9+	9	6	9	9	8	-	9+	9	9	9+	9	9	9	9+	-	8	9+	9+	3	9	9+	-	1	9+	9	-	9	9+	20
21	7	-	8	7	1	-	9+	9	7	9+	9+	8	1	9+	8	9	9	9+	9	9	9	-	6	9	9+	3	9	9+	-	-	9+	5*	-	9+	9+	21
22	9	2	9+	9	8	-	9+	9	7	9+	9+	9	4	9+	2	9+	9+	9	9	9	9+	-	9+	9+	9	1	9+	9+	-	5	9+	4*	-	9	6	22
23	9	-	9+	9	8	-	9+	9	7	9+	9+	9	-	9+	1	9+	9+	9	9	9	9+	-	9+	9+	6	-	9	9+	-	7	9+	2*	-	9	2	23

**Table 6**

The number of hours per day when a particular band is open to the target geographic areas in [Table 4](#), as related to the level of solar activity (Very Low, Medium and Very High). This table is customized for Boston to the rest of the world. Some paths are open 24 hours a day, plus or minus QRM and local QRN, no matter what the level of solar activity is. See [CD-ROM](#) for other transmitting locations.

MA (Boston)

Hours Open to Each Region for Very-Low/Medium/Very-High SSNs

80 Meters:

Month	Europe	Far East	So. Amer.	Africa	So. Asia	Oceania	No. Amer.
Jan	17/17/16	5/ 4/ 3	17/17/16	16/16/15	8/ 7/ 5	11/10/ 9	24/24/24
Feb	17/16/15	3/ 3/ 2	17/16/16	15/15/14	6/ 4/ 4	10/ 9/ 9	24/24/24
Mar	15/15/14	3/ 2/ 1	16/16/15	15/13/13	4/ 4/ 3	9/ 8/ 7	24/24/24
Apr	13/13/12	1/ 0/ 0	16/16/14	13/13/13	3/ 3/ 1	9/ 8/ 7	24/24/24
May	12/11/10	0/ 0/ 0	16/15/14	12/11/10	2/ 1/ 1	7/ 6/ 6	24/24/24
Jun	10/ 9/ 8	0/ 0/ 0	14/14/14	11/10/10	1/ 1/ 0	6/ 5/ 5	24/24/24
Jul	11/11/ 9	0/ 0/ 0	15/14/14	11/11/11	2/ 1/ 1	7/ 6/ 5	24/24/24
Aug	13/11/11	0/ 0/ 0	16/16/14	13/12/11	3/ 2/ 1	7/ 7/ 6	24/24/24
Sep	14/13/11	2/ 1/ 0	17/16/14	13/13/12	4/ 4/ 2	9/ 8/ 8	24/24/24
Oct	15/15/13	3/ 2/ 1	17/17/16	14/14/13	5/ 4/ 4	9/ 9/ 7	24/24/24
Nov	17/17/15	4/ 4/ 2	17/17/16	16/15/14	8/ 7/ 4	11/10/ 9	24/24/24
Dec	19/18/17	7/ 6/ 4	18/18/17	16/16/16	11/ 9/ 7	12/11/11	24/24/24

40 Meters:

Month	Europe	Far East	So. Amer.	Africa	So. Asia	Oceania	No. Amer.
Jan	24/24/24	15/16/15	24/24/21	21/20/19	21/21/19	19/18/15	24/24/24
Feb	24/24/21	13/11/11	24/23/20	20/19/18	19/19/17	16/15/14	24/24/24
Mar	23/22/19	10/ 9/ 7	24/21/18	19/17/17	17/17/13	13/13/13	24/24/24
Apr	21/19/18	8/ 6/ 4	22/20/18	17/16/15	16/11/ 8	13/13/11	24/24/24
May	19/17/17	5/ 4/ 3	22/18/17	17/16/14	9/ 8/ 5	12/11/10	24/24/24
Jun	17/15/13	4/ 2/ 2	22/18/16	16/15/14	7/ 5/ 5	11/10/ 9	24/24/24
Jul	18/16/15	5/ 4/ 2	24/18/17	17/15/14	8/ 7/ 5	12/11/10	24/24/24
Aug	19/17/16	7/ 5/ 4	24/19/18	18/16/15	11/10/ 6	13/12/11	24/24/24
Sep	22/21/17	9/ 8/ 5	23/20/18	18/17/16	14/11/ 7	13/13/12	24/24/24
Oct	24/23/20	12/11/ 8	24/23/19	20/18/17	17/16/14	16/13/13	24/24/24
Nov	24/24/22	14/13/12	24/24/20	21/19/18	21/20/17	17/17/13	24/24/24
Dec	24/24/24	18/19/22	24/24/21	23/21/19	24/23/22	21/19/18	24/24/24

20 Meters:

Month	Europe	Far East	So. Amer.	Africa	So. Asia	Oceania	No. Amer.
Jan	13/16/22	15/22/22	24/24/24	20/21/21	18/20/22	18/23/22	24/24/24
Feb	12/18/23	13/21/24	24/24/24	22/22/24	15/21/24	18/23/24	24/24/24
Mar	15/18/24	17/20/24	24/24/24	22/24/24	18/21/24	16/24/24	24/24/24
Apr	15/20/24	19/22/24	24/24/24	21/24/24	19/22/24	18/24/24	24/24/24
May	19/23/24	22/24/24	24/24/24	23/24/24	23/24/24	21/24/24	24/24/24
Jun	22/24/24	24/24/24	24/24/24	24/24/24	24/24/24	24/24/24	24/24/24
Jul	19/24/24	24/24/24	24/24/24	21/24/24	24/24/24	23/24/24	24/24/24
Aug	15/20/24	20/24/24	24/24/24	20/24/24	20/24/24	19/24/24	24/24/24
Sep	16/19/24	17/21/24	24/24/24	21/24/24	18/21/24	17/24/24	24/24/24
Oct	15/21/24	16/20/24	24/24/24	22/24/24	19/22/24	17/24/24	24/24/24
Nov	14/20/23	14/22/24	24/24/24	20/24/24	17/21/24	19/23/24	24/24/24
Dec	11/17/24	13/22/24	24/24/24	17/23/24	12/22/24	16/24/24	24/24/24

15 Meters:

Month	Europe	Far East	So. Amer.	Africa	So. Asia	Oceania	No. Amer.
Jan	4/ 6/ 7	2/ 9/13	12/15/16	9/13/13	3/ 4/ 7	9/12/13	24/15/16
Feb	4/ 7/12	4/10/14	13/18/23	11/13/16	3/ 7/13	8/13/15	22/16/19
Mar	6/ 9/14	2/13/15	14/21/24	13/17/22	5/11/17	10/14/17	15/16/23
Apr	0/10/18	3/13/18	15/23/24	15/18/24	9/15/19	11/15/21	16/16/24
May	1/13/16	6/10/19	17/20/24	14/18/24	13/17/18	10/16/19	20/19/24
Jun	0/ 2/16	0/ 9/15	16/21/24	14/18/24	5/15/18	10/12/20	24/22/22
Jul	0/ 2/16	0/ 5/18	15/19/24	12/18/24	0/12/18	4/12/20	24/22/21
Aug	0/ 2/14	0/ 8/17	14/18/22	13/16/22	0/12/17	6/10/19	22/19/21
Sep	1/10/17	6/13/17	14/16/24	13/17/22	9/14/17	9/14/17	16/16/22
Oct	7/11/17	10/13/17	12/16/22	12/15/22	7/12/17	12/13/15	18/15/22
Nov	5/ 8/14	8/11/14	12/16/22	11/14/17	3/ 7/16	10/13/15	20/16/21
Dec	3/ 6/ 9	2/10/13	12/15/23	8/13/15	2/ 4/12	9/12/14	24/15/18

10 Meters:

Month	Europe	Far East	So. Amer.	Africa	So. Asia	Oceania	No. Amer.
Jan	0/ 1/ 4	0/ 1/ 8	6/11/13	0/ 7/10	0/ 1/ 3	0/ 3/11	23/24/24
Feb	0/ 2/ 7	0/ 2/10	8/12/14	0/ 9/13	0/ 3/ 5	0/ 7/13	24/24/24
Mar	0/ 0/ 8	0/ 1/10	10/14/20	1/11/14	0/ 0/ 8	0/ 7/13	23/24/24
Apr	0/ 0/ 8	0/ 0/ 8	7/14/21	0/12/17	0/ 0/13	0/ 5/11	18/24/24
May	0/ 0/ 0	0/ 0/ 1	7/12/20	1/10/17	0/ 1/12	0/ 2/11	17/20/22
Jun	0/ 0/ 0	0/ 0/ 0	7/11/18	0/ 3/17	0/ 0/ 0	0/ 0/ 2	21/19/23
Jul	0/ 0/ 0	0/ 0/ 0	2/ 9/19	0/ 2/18	0/ 0/ 7	0/ 0/ 6	16/16/24
Aug	0/ 0/ 0	0/ 0/ 0	2/10/17	0/ 1/16	0/ 0/10	0/ 0/ 8	17/17/24
Sep	0/ 0/ 8	0/ 1/10	7/13/18	0/11/16	0/ 0/10	0/ 2/ 9	19/24/24
Oct	0/ 5/ 9	0/ 2/11	10/12/16	7/12/14	0/ 5/ 9	0/ 8/12	24/24/24
Nov	0/ 4/ 8	0/ 3/11	9/12/15	5/10/13	0/ 3/ 6	4/10/12	24/24/24
Dec	0/ 3/ 6	0/ 1/ 8	8/11/13	1/ 8/12	0/ 1/ 4	2/ 7/12	23/23/24



night the band sounds dead, simply because everyone is either asleep or operating on a lower frequency.

For the 40-meter band in [Table 6](#), during the month of January the band is open to Europe for 24 hours a day, whatever the level of solar activity is. Look now at [Table 4](#), and you'll see that the predicted level for Very Low solar activity varies from S4 to S9. Local QRM or QRN would probably disrupt communications on 40 meters in Europe for stateside signals weaker than perhaps S3 or S4. Even though you might well be able to hear Europeans from New England during the day, they probably won't hear you because of local conditions, including local S9+ European stations and atmospheric noise from nearby thunderstorms. New England stations with big antennas can often hear Europeans on 40 meters as early as noontime, but must wait until the late afternoon before the Europeans can hear them above their local noise and QRM.

Let's say that you want to boost your country total on

80 meters by concentrating on stations in the South Pacific. The best months would be from November to February in terms of the number of hours per day when the 80-meter band is open to Oceania. You can see by reading across the line for each month that the level of solar activity is not hugely important on 80 meters to any location. Common experience (backed by the statistical information in [Table 6](#)) is that the 80-meter band is open only marginally longer when sunspots are low.

This is true to a greater extent on 40 meters. Thus you may hear the generalization that the low bands tend to be better during periods of low solar activity, while the upper HF bands (above 10 MHz) tend to be better when the sun is more active.

[Table 6](#) can give you a good handle on what months are the most productive for DXing and contesting. It should be no surprise to most veteran operators that the fall and winter months are the best times to work DX.

## Do-It-Yourself Propagation Prediction

Very reliable methods of determining the MUF for any given radio path have been developed over the last 50 years. As discussed previously, these methods are all based on the smoothed sunspot number as the measure of solar activity. It is for this reason that smoothed sunspot numbers hold so much meaning for radio amateurs and others concerned with radio-wave propagation—they are the link to past (and future) propagation conditions.

Early on, the prediction of propagation conditions required tedious work with numerous graphs, along with charts of frequency contours overlaid, or overprinted, on world maps. The basic materials were available from an agency of the US government. Monthly publications provided the frequency-contour data a few months in advance. Only rarely did amateurs try their hand at predicting propagation conditions using these hard-to-use methods.

Today's powerful PCs have given the amateur wonderful tools to make quick-and-easy HF propagation predictions, whether for a contest or a DXpedition. There are two categories of programs available for the ham serious about propagation prediction. Programs falling into the first category are designed for long-range station planning. As previously described, *IONCAP* is probably the best-known program in this first category. Organizations such as the Voice of America use *VOACAP*, a version of *IONCAP*, to plan their massive installations. Unfortunately, these programs can best be characterized as being “ponderous” to use. Results must be analyzed thoroughly to gain useful information from the huge mass of data produced.

The second category of prediction programs is most interesting to amateurs. These programs are designed for quick-and-easy predictions of MUF and band openings. See [Table 7](#) for a listing of a number of popular programs. The basic information required is the smoothed sunspot number

(SSN) or smoothed solar flux, the date (month and day), and the latitudes and longitudes at the two ends of the radio path. The latitude and longitude, of course, are used to determine the great-circle radio path. The date is used to determine the latitude of the Sun, and this, with the sunspot number, is used to determine the properties of the ionosphere at critical points on the path.

Just because a computer program predicts that a band will be open on a particular path, it doesn't follow that the Sun and the ionosphere will always cooperate! A sudden solar flare can result in a major geomagnetic storm, taking out HF communication anywhere from hours to days. There is still art, as well as a lot of science, in predicting propagation. In times of quiet geomagnetic activity, however, the prediction programs are good at forecasting band openings and closings.

### Obtaining Sunspot Number/Solar Flux Data

After one has chosen and then set up a computer program, there is still one more necessary ingredient—a knowledge (or an estimation)—of the sunspot number or solar flux level for the period in question. A caution must be stated here—for best accuracy and consistency, use the average of solar flux values taken from actual observations, perhaps from WWV/WWVH, over the previous three or four days. Solar flux numbers can vary dramatically from day to day, but the Earth's ionosphere is relatively slow to respond to instantaneous changes in solar radiation. This caveat also holds for sunspot numbers derived, using [Fig 17](#), from WWV/WWVH solar flux numbers.

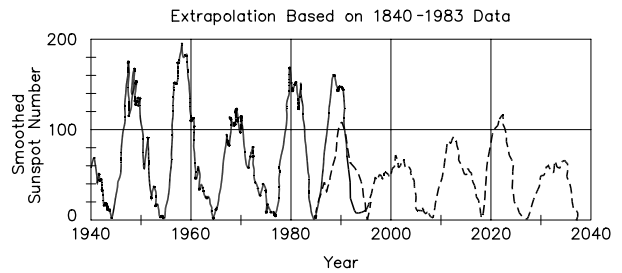
[Fig 34](#) shows a graph produced in the early 1980s of smoothed sunspot numbers for Solar Cycles 17 through 21, with predictions for Cycles 22 through 26. The graph covers a period of 100 years, from 1940 to 2040, and may be used for making long-term or historical calculations. Just remember

that the graph shows smoothed numbers. The solar activity at any given time can be significantly lower or significantly higher than the graph indicates. In fact, Cycle 22 peaked at the end of 1989, as predicted, but with a monthly smoothed sunspot level of 158, quite a bit higher than predicted.

### WWV PROPAGATION DATA

For the most current data on what the Sun is doing, National Institute of Standards and Technology stations WWV and WWVH broadcast information on solar activity at 18 and 45 minutes past each hour, respectively. These propagation bulletins give the solar flux, geomagnetic A-Index, Boulder K-Index, and a brief statement of solar and geomagnetic activity in the past and coming 24-hour periods, in that order. The solar flux and A-Index are changed daily with the 2118 UT bulletin, the rest every three hours—0018, 0318, 0618 UT and so on. On the Web, up-to-date WWV information can be found at: <ftp://ftp.sel.noaa.gov/pub/latest/wwv.txt>.

The NOAA Web page has the latest forecasts: <http://www.sel.noaa.gov/forecast.html>, and some other useful Web sites are: <http://dx.qsl.net/propagation/>,



**Fig 34—Smoothed sunspot number, with predictions, from 1940 to 2040. This was extrapolated based on data from 1840 to 1983. Cycle 22 actually peaked in Nov 1989, at a monthly smoothed sunspot number of 158. Propagation on the higher frequencies throughout the peak of Cycle 22 was good to excellent, since the monthly smoothed sunspot number stayed at 100 or above from July 1988 through May 1992. (Courtesy of Naval Ocean Systems Center, San Diego.)**

**Table 7  
Features and Attributes of Propagation Prediction Programs**

	ASAPS V. 4	VOACAP Windows	HFX 1.06	MINIPROP PLUS 2.5	CAPMan	WinCAP Wizard 2
User Friendliness	Good	Good	Excellent	Good	Good	Good
Review data	Yes	Yes	Yes	Yes	Yes	Yes
User library of QTHs	Yes	Yes	Yes	Yes	Yes	Yes
Bearings, distances	Yes	Yes	Yes	Yes	Yes	Yes
MUF calculation	Yes	Yes	Yes	Yes	Yes	Yes
LUF calculation	Yes	Yes	Yes	No	Yes	Yes
Wave angle calculation	Yes	Yes	Yes	Yes	Yes	Yes
Vary minimum wave angle	Yes	Yes	Yes	Yes	Yes	Yes
Path regions and hops	Yes	Yes	Yes	Yes	Yes	Yes
Multipath effects	Yes	Yes	Yes	No	Yes	Yes
Path probability	Yes	Yes	Yes	Yes	Yes	Yes
Signal strengths	Yes	Yes	Yes	Yes	Yes	Yes
S/N ratios	Yes	Yes	Yes	No	Yes	Yes
Long path calculation	Yes	Yes	Yes	Yes	Yes	Yes
Antenna selection	Yes	Yes	Yes	Indirectly	Yes	Isotropic
Vary antenna height	Yes	Yes	Yes	Indirectly	Yes	No
Vary ground characteristics	Yes	Yes	No	No	Yes	No
Vary transmit power	Yes	Yes	Yes	Indirectly	Yes	Yes
Graphic displays	Yes	Yes	Yes	Yes	Yes	Yes
UT-day graphs	Yes	Yes	Yes	Yes	Yes	Yes
Color monitor support	Yes	Yes	Yes	Yes	Yes	Yes
Hard disk required	Yes	Yes	Yes	No	Yes	Yes
Save data to disk	Yes	Yes	Yes	No	Yes	Yes
Area Mapping	No	Yes	Yes	Yes	Yes	No
Documentation	Yes	On-line	On-line	Yes	Yes	Yes
Price class	\$275+	free†	\$129	\$60	\$89+	\$29.95+

“Review data” indicates ability to review previous program display screens.

Price classes are for early 1999 and subject to change.

†Available on the World Wide Web at: <http://elbert.its.bldrdoc.gov/hf.html>

+ Shipping and handling extra.

<http://www.dxlc.com/solar>, <http://hfradio.org/propagation.html>. Finally, the Solar Terrestrial Dispatch page contains a wealth of propagation-related information: <http://solar.uleth.ca>. You may also access propagation information on your local PacketCluster. Use the command SH/WWV/*n*, where *n* is the number of spots you wish to see (five is the default).

### The A-Index

The WWV/WWVH A-Index is a daily figure for the state of activity of the Earth's magnetic field. It is updated with the 2118/2145 UT bulletin. The A-Index tells you mainly how yesterday was, but it is very revealing when charted regularly, because geomagnetic disturbances nearly always recur at four-week intervals.

### The K-Index

The K-Index (new every three hours) reflects Boulder readings of the Earth's geomagnetic field in the hours just preceding the bulletin data changes. It is the nearest thing to current data on radio propagation available. With new data every three hours, K-Index trend is important. Rising is bad news; falling is good, especially related to propagation on paths involving latitudes above 30° north. Because this is a Boulder, Colorado, reading of geomagnetic activity, it may not correlate closely with conditions in other areas.

The K-Index is also a timely clue to aurora possibilities. Values of 3, and rising, warn that conditions associated with auroras and degraded HF propagation are present in the Boulder area at the time of the bulletin's preparation.

## BIBLIOGRAPHY

Source material and more extended discussion of topics covered in this chapter can be found in the references given below.

- E. V. Appleton and W.R. Piggott, "Ionospheric Absorption Measurements during a Sunspot Cycle," *J. Atmos. Terr. Phys.*, Vol 3, p 141, 1954.
- D. Bilitza, *International Reference Ionosphere (IRI 90)*, National Space Science Data Center, Greenbelt, MD, 1990.
- D. Bray, "Method of Determining VHF/HF Station Capabilities," *QST*, Nov 1961.
- A. Brekke, "Physics of the Upper Polar Atmosphere," (John Wiley and Sons: New York, 1997).
- R. R. Brown, "Demography, DXpeditions and Magneto-Ionic Theory," *The DX Magazine*, Vol. X, No. 2, p 44, Mar/Apr 1998.
- R. R. Brown, "Signal Ducting on the 160 Meter Band," *Communications Quarterly*, p 65, Spring 1998.
- R. R. Brown, "Unusual Low-Frequency Signal Propagation at Sunrise," *Communications Quarterly*, p 67, Fall 1998.
- R. R. Brown, "Atmospheric Ozone, a Meteorological Factor in Low-Frequency and 160 Meter Propagation," *Communications Quarterly*, Spring 1999.
- K. Davies, *Ionospheric Radio* (London: Peter Peregrinus Ltd, 1990). Excellent technical reference.
- R. Garcia, S. Solomon, S. Avery, G. C. Reid, "Transport

- of Nitric Oxide and the D-Region Winter Anomaly," *J. Geophys. Res.*, Vol 92, p 977, 1987.
- L. A. Hajkovicz, R. D. Hunsucker, "A Simultaneous Observation of Large-Scale Periodic TIDS in both Hemispheres Following an Onset of Auroral Disturbances," *Planet. Space Sci.*, Vol 35, No. 6, p 785, 1987.
- J. Hall, "Propagation Predictions and Personal Computers," Technical Correspondence, *QST*, Dec 1990, pp 58-59 (description of *IONCAP* as used for ARRL publications).
- E. Harper, *Rhombic Antenna Design* (New York: D. Van Nostrand Co, Inc, 1941).
- R. D. Hunsucker, "The Sources of Gravity Waves," *Nature*, Vol 328, No. 6127, p 204, 1987.
- W. D. Johnston, Computer-calculated and computer-drawn great-circle maps are offered. An 11 × 14-inch map is custom made for your location. Write to K5ZI, PO Box 640, Organ, NM 88052, tel 505-382-7804.
- T. L. Killeen, R.M. Johnsson, "Upper Atmospheric Waves, Turbulence, and Winds: Importance for Mesospheric and Thermospheric Studies," <http://earth.agu.org/revgeophys/killee00/killee00.html>.
- J. L. Lynch, "The Maunder Minimum," *QST*, Jul 1976, pp 24-26.
- L. F. McNamara, *The Ionosphere: Communications, Surveillance, and Direction Finding* (Malabar, FL: Krieger Publishing Company). Another excellent technical reference on propagation.
- L. F. McNamara, *Radio Amateur's Guide to the Ionosphere* (Malabar, FL: Krieger Publishing Company, 1994). Excellent, quite-readable text on HF propagation.
- A. K. Paul, "Medium Scale Structure of the F Region," *Radio Science*, Volume 24, No. 3, p. 301, 1989.
- W. R. Piggott, K. Rawer, "URSI Handbook of Ionogram Interpretation and Reduction," Report UAG-50. World Data Center A for Solar-Terrestrial Physics, Boulder, CO, 1975.
- E. Pocock, "Sporadic-E Propagation at VHF: A Review of Progress and Prospects," *QST*, Apr 1988, pp 33-39.
- E. Pocock, "Auroral-E Propagation at 144 MHz," *QST*, Dec 1989, pp 28-32.
- E. Pocock, "Propagation Forecasting During Solar Cycle 22," *QST*, Jun 1989, pp 18-20.
- G. C. Reid, "Ion Chemistry of the D-region," *Advances in Atomic and Molecular Physics*, Vol 12, Academic Press, 1976.
- R. B. Rose, "MINIMUF: A Simplified MUF-Prediction Program for Microcomputers," *QST*, Dec 1982, pp 36-38.
- M. L. Salby, "Fundamentals of Atmospheric Physics," (Academic Press: Boulder, CO, 1996).
- S. C. Shallon, W6EL: *MINIPROP PLUS*, a commercially prepared program written for Amateur Radio users; 11058 Queensland St, Los Angeles, CA 90034-3029.
- R. D. Straw, *All the Right Angles* (New Bedford, PA: LTA, 1993)
- R. D. Straw, "ASAPS and CAPMAN: HF Propagation-Prediction Software for the IBM PC," *QST*, Dec 1994, pp 79-81.
- R. D. Straw, "Heavy-Duty HF Propagation-Prediction/Analysis Software," Part 1: *QST*, Sep 1996, pp 28-32; Part 2: *QST*, Oct 1996, pp 28-30.

# Transmission Lines

## Basic Theory of Transmission Lines

The desirability of installing an antenna in a clear space, not too near buildings or power and telephone lines, cannot be stressed too strongly. On the other hand, the transmitter that generates the RF power for driving the antenna is usually, as a matter of necessity, located some distance from the antenna terminals. The connecting link between the two is the RF *transmission line*, feeder or feed line. Its sole purpose is to carry RF power from one place to another, and to do it as efficiently as possible. That is, the ratio of the power *transferred* by the line to the power *lost* in it should be as large as the circumstances permit.

At radio frequencies, every conductor that has appreciable length compared with the wavelength in use *radiates* power—every conductor is an antenna. Special care must be used, therefore, to minimize radiation from the conductors used in RF transmission lines. Without such care, the power radiated by the line may be much larger than that which is lost in the resistance of conductors and dielectrics (insulating materials). Power loss in resistance is inescapable, at least to a degree, but loss by radiation is largely avoidable.

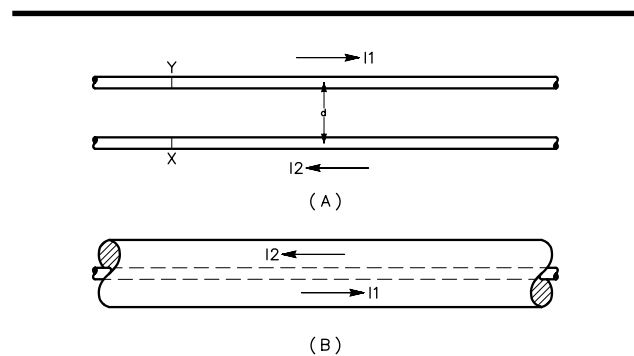
Radiation loss from transmission lines can be prevented by using two conductors arranged and operated so the electromagnetic field from one is balanced everywhere by an equal and opposite field from the other. In such a case, the resultant field is zero everywhere in space—there is no radiation from the line.

For example, **Fig 1A** shows two parallel conductors having currents  $I_1$  and  $I_2$  flowing in opposite directions. If the current  $I_1$  at point Y on the upper conductor has the same amplitude as the current  $I_2$  at the corresponding point X on the lower conductor, the fields set up by the two currents are equal in magnitude. Because the two currents are flowing in opposite directions, the field from  $I_1$  at Y is  $180^\circ$  out of phase with the field from  $I_2$  at X. However, it takes a measurable interval of time for the field from X to travel to Y. If  $I_1$  and  $I_2$  are alternating currents, the phase of the field from  $I_1$  at Y changes in such a time interval, so at the instant the field from X reaches Y, the two fields at Y are not exactly

$180^\circ$  out of phase. The two fields are exactly  $180^\circ$  out of phase at every point in space only when the two conductors occupy the same space—an obviously impossible condition if they are to remain separate conductors.

The best that can be done is to make the two fields cancel each other as completely as possible. This can be achieved by keeping the distance  $d$  between the two conductors small enough so the time interval during which the field from X is moving to Y is a very small part of a cycle. When this is the case, the phase difference between the two fields at any given point is so close to  $180^\circ$  that cancellation is nearly complete.

Practical values of  $d$  (the separation between the two conductors) are determined by the physical limitations of line construction. A separation that meets the condition of being “very small” at one frequency may be quite large at another. For example, if  $d$  is 6 inches, the phase difference between the two fields at Y is only a fraction of a degree if the frequency is 3.5 MHz. This is because a distance of 6 inches is such a small fraction of a wavelength ( $1 \lambda = 281$  feet) at



**Fig 1—Two basic types of transmission lines.**

3.5 MHz. But at 144 MHz, the phase difference is  $26^\circ$ , and at 420 MHz, it is  $77^\circ$ . In neither of these cases could the two fields be considered to “cancel” each other. Conductor separation must be very small in comparison with the wavelength used; it should never exceed 1% of the wavelength, and smaller separations are desirable. Transmission lines consisting of two parallel conductors as in Fig 1A are called *open-wire lines*, *parallel-conductor lines* or *two-wire lines*.

A second general type of line construction is shown in Fig 1B. In this case, one of the conductors is tube-shaped and encloses the other conductor. This is called a *coaxial line* (coax, pronounced “co-ax”) or *concentric line*. The current flowing on the inner conductor is balanced by an equal current flowing in the opposite direction on the inside surface of the outer conductor. Because of skin effect, the current on the inner surface of the outer conductor does not penetrate far enough to appear on the outside surface. In fact, the total electromagnetic field outside the coaxial line (as a result of currents flowing on the conductors inside) is always zero, because the outer conductor acts as a shield at radio frequencies. The separation between the inner conductor and the outer conductor is therefore unimportant from the standpoint of reducing radiation.

A third general type of transmission line is the *waveguide*. Waveguides are discussed in detail in Chapter 18.

### CURRENT FLOW IN LONG LINES

In Fig 2, imagine that the connection between the battery and the two wires is made instantaneously and then broken. During the time the wires are in contact with the battery terminals, electrons in wire 1 will be attracted to the positive battery terminal and an equal number of electrons in wire 2 will be repelled from the negative terminal. This happens only near the battery terminals at first, because electromagnetic waves do not travel at infinite speed. Some time does elapse before the currents flow at the more extreme parts of the wires. By ordinary standards, the elapsed time

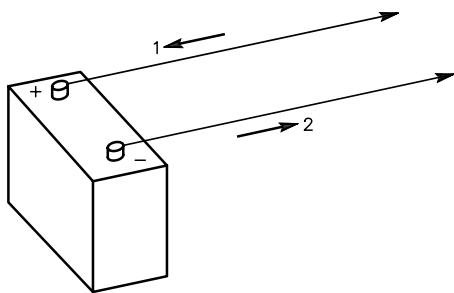


Fig 2—A representation of current flow on a long transmission line.

is very short. Because the speed of wave travel along the wires may approach the speed of light at 300,000,000 meters per second, it becomes necessary to measure time in millionths of a second (microseconds).

For example, suppose that the contact with the battery is so short that it can be measured in a very small fraction of a microsecond. Then the “pulse” of current that flows at the battery terminals during this time can be represented by the vertical line in Fig 3. At the speed of light this pulse travels 30 meters along the line in 0.1 microsecond, 60 meters in 0.2 microsecond, 90 meters in 0.3 microsecond, and so on, as far as the line reaches.

The current does not exist all along the wires; it is only present at the point that the pulse has reached in its travel. At this point it is present in both wires, with the electrons moving in one direction in one wire and in the other direction in the other wire. If the line is infinitely long and has no resistance (or other cause of energy loss), the pulse will travel undiminished forever.

By extending the example of Fig 3, it is not hard to see that if, instead of one pulse, a whole series of them were started on the line at equal time intervals, the pulses would travel along the line with the same time and distance spacing between them, each pulse independent of the others. In fact, each pulse could even have a different amplitude if the battery voltage were varied between pulses. Furthermore, the pulses could be so closely spaced that they touched each other, in which case current would be present everywhere along the line simultaneously.

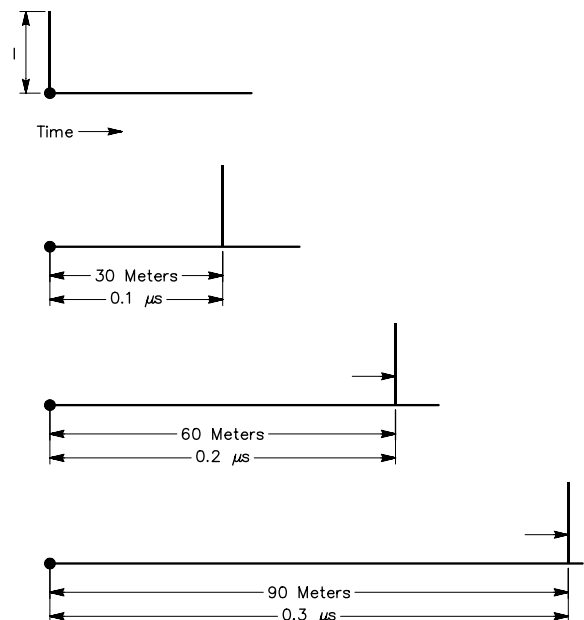


Fig 3—A current pulse traveling along a transmission line at the speed of light would reach the successive positions shown at intervals of 0.1 microsecond.

It follows from this that an alternating voltage applied to the line would give rise to the sort of current flow shown in Fig 4. If the frequency of the ac voltage is 10,000,000 hertz or 10 MHz, each cycle occupies 0.1 μsecond, so a complete cycle of current will be present along each 30 meters of line. This is a distance of one wavelength. Any currents at points B and D on the two conductors occur one cycle later in time than the currents at A and C. Put another way, the currents initiated at A and C do not appear at B and D, one wavelength away, until the applied voltage has gone through a complete cycle.

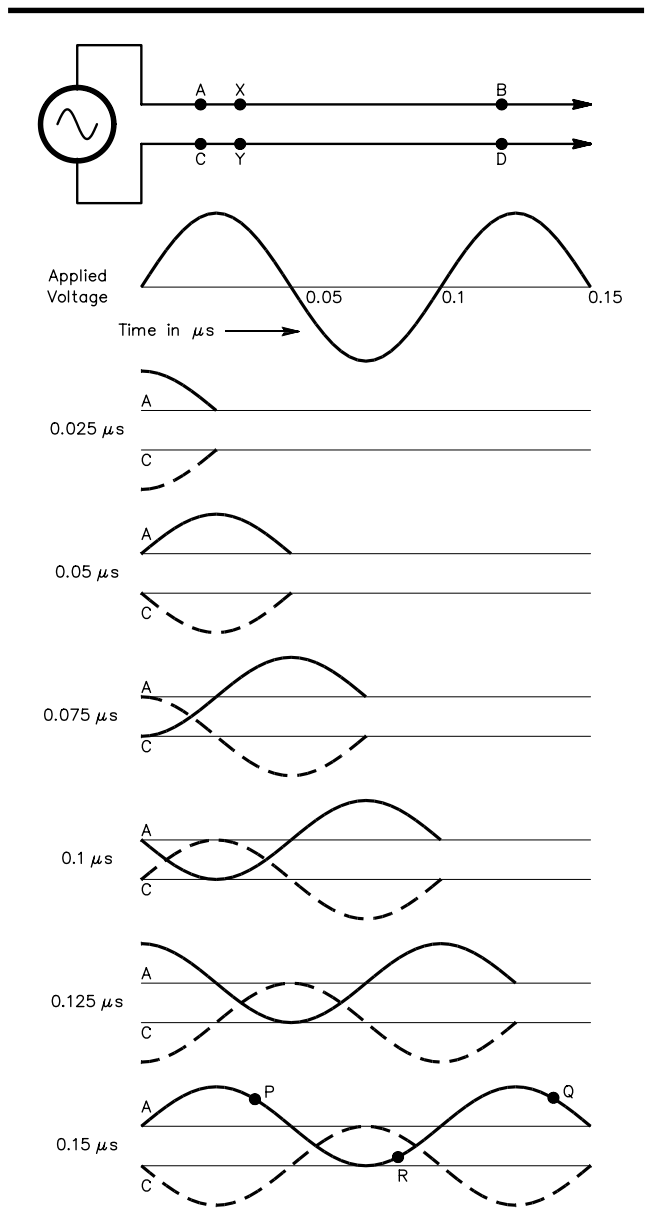


Fig 4—Instantaneous current along a transmission line at successive time intervals. The frequency is 10 MHz; the time for each complete cycle is 0.1 microsecond.

Because the applied voltage is always changing, the currents at A and C change in proportion. The current a short distance away from A and C—for instance, at X and Y—is not the same as the current at A and C. This is because the current at X and Y was caused by a value of voltage that occurred slightly earlier in the cycle. This situation holds true all along the line; at any instant the current anywhere along the line from A to B and C to D is different from the current at any other point on that section of the line.

The remaining series of drawings in Fig 4 shows how the instantaneous currents might be distributed if we could take snapshots of them at intervals of 1/4 cycle. The current travels out from the input end of the line in waves. At any given point on the line, the current goes through its complete range of ac values in one cycle, just as it does at the input end. Therefore (if there are no losses) an ammeter inserted in either conductor reads exactly the same current at any point along the line, because the ammeter averages the current over a whole cycle. (The phases of the currents at any two separate points are different, but the ammeter cannot show phase.)

### VELOCITY OF PROPAGATION

In the example above it was assumed that energy travels along the line at the velocity of light. The actual velocity is very close to that of light only in lines in which the insulation between conductors is air. The presence of dielectrics other than air reduces the velocity.

Current flows at the speed of light in any medium only in a vacuum, although the speed in air is close to that in a vacuum. Therefore, the time required for a signal of a given frequency to travel down a length of practical transmission line is *longer* than the time required for the same signal to travel the same distance in free space. Because of this propagation delay, 360° of a given wave exists in a physically shorter distance on a given transmission line than in free space. The exact delay for a given transmission line is a function of the properties of the line, mainly the dielectric constant of the insulating material between the conductors. This delay is expressed in terms of the speed of light (either as a percentage or a decimal fraction), and is referred to as velocity factor (VF). The velocity factor is related to the dielectric constant ( $\epsilon$ ) by

$$VF = \frac{1}{\sqrt{\epsilon}} \quad (\text{Eq 1})$$

The wavelength in a practical line is always shorter than the wavelength in free space, which has a dielectric constant  $\epsilon = 1.0$ . Whenever reference is made to a line as being a half wavelength or quarter wavelength long ( $\lambda/2$  or  $\lambda/4$ ), it is understood that what is meant by this is the *electrical* length of the line. The physical length corresponding to an electrical wavelength on a given line is given by

$$\lambda(\text{feet}) = \frac{983.6}{f} \times VF \quad (\text{Eq 2})$$

where

f = frequency in MHz  
VF = velocity factor

Values of VF for several common types of lines are given later in this chapter. The actual VF of a given cable varies slightly from one production run or manufacturer to another, even though the cables may have exactly the same specifications.

As we shall see later, a quarter-wavelength line is frequently used as an impedance transformer, and so it is convenient to calculate the length of a quarter-wave line directly by

$$\lambda/4 = \frac{245.9}{f} \times VF \quad (\text{Eq 2A})$$

### CHARACTERISTIC IMPEDANCE

If the line could be *perfect*—having no resistive losses—a question might arise: What is the amplitude of the current in a pulse applied to this line? Will a larger voltage result in a larger current, or is the current theoretically infinite for an applied voltage, as we would expect from applying Ohm’s Law to a circuit without resistance? The answer is that the current does depend directly on the voltage, just as though resistance were present.

The reason for this is that the current flowing in the line is something like the charging current that flows when a battery is connected to a capacitor. That is, the line has capacitance. However, it also has inductance. Both of these are “distributed” properties. We may think of the line as being composed of a whole series of small inductors and capacitors, connected as in Fig 5, where each coil is the inductance of an extremely small section of wire, and the capacitance is that existing between the same two sections. Each series inductor acts to limit the rate at which current can charge the following shunt capacitor, and in so doing establishes a very important property of a transmission line: its *surge impedance*, more commonly known as its *characteristic impedance*. This is abbreviated by convention as  $Z_0$ .

### TERMINATED LINES

The value of the characteristic impedance is equal to  $\sqrt{L/C}$  in a perfect line—that is, one in which the conductors

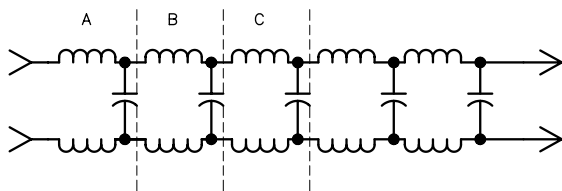


Fig 5—Equivalent of an ideal (lossless) transmission line in terms of ordinary circuit elements (lumped constants). The values of inductance and capacitance depend on the line construction.

have no resistance and there is no leakage between them—where L and C are the inductance and capacitance, respectively, per unit length of line. The inductance decreases with increasing conductor diameter, and the capacitance decreases with increasing spacing between the conductors. Hence a line with closely spaced large conductors has a relatively low characteristic impedance, while one with widely spaced thin conductors has a high impedance. Practical values of  $Z_0$  for parallel-conductor lines range from about 200 to 800  $\Omega$ . Typical coaxial lines have characteristic impedances from 30 to 100  $\Omega$ . Physical constraints on practical wire diameters and spacings limit  $Z_0$  values to these ranges.

In the earlier discussion of current traveling along a transmission line, we assumed that the line was infinitely long. Practical lines have a definite length, and they are terminated in a load at the “output” end (the end to which the power is delivered). In Fig 6, if the load is a pure resistance of a value equal to the characteristic impedance of a perfect, lossless line, the current traveling along the line to the load finds that the load simply “looks like” more transmission line of the same characteristic impedance.

The reason for this can be more easily understood by considering it from another viewpoint. Along a transmission line, power is transferred successively from one elementary section in Fig 5 to the next. When the line is infinitely long, this power transfer goes on in one direction—away from the source of power.

From the standpoint of Section B, Fig 5, for instance, the power transferred to section C has simply disappeared in C. As far as section B is concerned, it makes no difference whether C has absorbed the power itself or has transferred it along to more transmission line. Consequently, if we substitute a load for section C that has the same electrical characteristics as the transmission line, section B will transfer power into it just as if it were more transmission line. A pure resistance equal to the characteristic impedance of C, which is also the characteristic impedance of the line, meets this condition. It absorbs all the power just as the infinitely long line absorbs all the power transferred by section B.

### Matched Lines

A line terminated in a load equal to the complex characteristic line impedance is said to be *matched*. In a matched transmission line, power is transferred outward

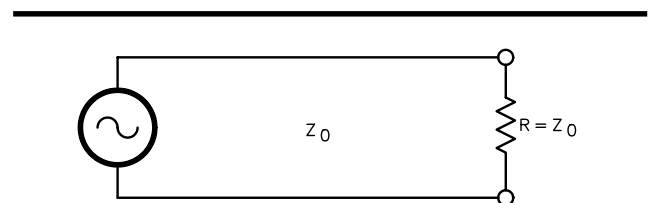


Fig 6—A transmission line terminated in a resistive load equal to the characteristic impedance of the line.

along the line from the source until it reaches the load, where it is completely absorbed. Thus with either the infinitely long line or its matched counterpart, the impedance presented to the source of power (the line-input impedance) is the same *regardless of the line length*. It is simply equal to the characteristic impedance of the line. The current in such a line is equal to the applied voltage divided by the characteristic impedance, and the power put into it is  $E^2/Z_0$  or  $I^2Z_0$ , by Ohm's Law.

### Mismatched Lines

Now take the case where the terminating load is *not* equal to  $Z_0$ , as in Fig 7. The load no longer looks like more line to the section of line immediately adjacent. Such a line is said to be *mismatched*. The more that the load impedance differs from  $Z_0$ , the greater the mismatch. The power reaching the load is not totally absorbed, as it was when the load was equal to  $Z_0$ , because the load requires a voltage to current ratio that is different from the one traveling along the line. The result is that the load absorbs only part of the power reaching it (the *incident power*); the remainder acts as though it had bounced off a wall and starts back along the line toward the source. This is known as *reflected power*, and the greater the mismatch, the larger is the percentage of the incident power that is reflected. In the extreme case where the load is zero (a short circuit) or infinity (an open circuit), *all* of the power reaching the end of the line is reflected back toward the source.

Whenever there is a mismatch, power is transferred in both directions along the line. The voltage to current ratio is the same for the reflected power as for the incident power, because this ratio is determined by the  $Z_0$  of the line. The voltage and current travel along the line in both directions

in the same wave motion shown in Fig 4. If the source of power is an ac generator, the incident (outgoing) voltage and the reflected (returning) voltage are simultaneously present all along the line. The actual voltage at any point along the line is the vector sum of the two components, taking into account the *phases* of each component. The same is true of the current.

The effect of the incident and reflected components on the behavior of the line can be understood more readily by considering first the two limiting cases—the short-circuited line and the open-circuited line. If the line is short-circuited as in Fig 7B, the voltage at the end must be zero. Thus the incident voltage must disappear suddenly at the short. It can do this only if the reflected voltage is opposite in phase and of the same amplitude. This is shown by the vectors in Fig 8. The current, however, does not disappear in the short circuit; in fact, the incident current flows through the short and there is in addition the reflected component in phase with it and of the same amplitude.

The reflected voltage and current must have the same amplitudes as the incident voltage and current, because no power is dissipated in the short circuit; all the power starts back toward the source. Reversing the phase of *either* the current or voltage (but not both) reverses the direction of power flow. In the short-circuited case the phase of the voltage is reversed on reflection, but the phase of the current is not.

If the line is open-circuited (Fig 7C) the current must be zero at the end of the line. In this case the reflected current is  $180^\circ$  out of phase with the incident current and has the same amplitude. By reasoning similar to that used in the short-circuited case, the reflected voltage must be in phase with the incident voltage, and must have the same amplitude. Vectors for the open-circuited case are shown in Fig 9.

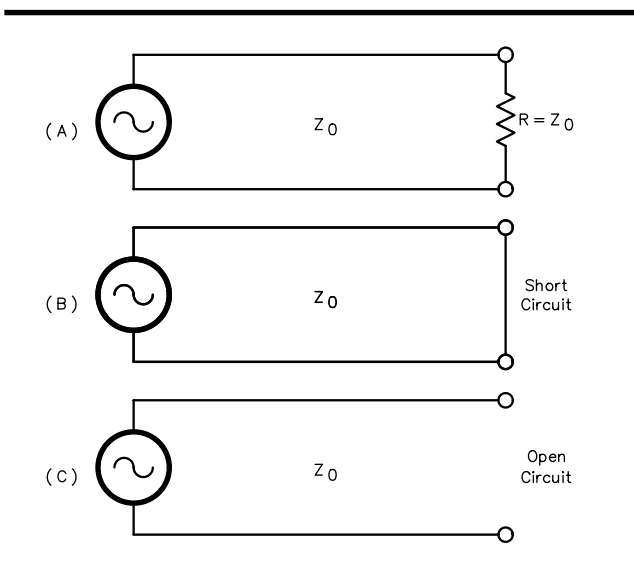


Fig 7—Mismatched lines; extreme cases. At A, termination not equal to  $Z_0$ ; at B, short-circuited line; At C, open-circuited line.

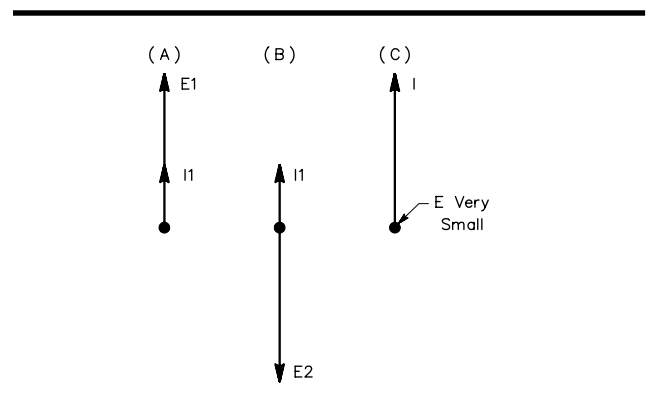
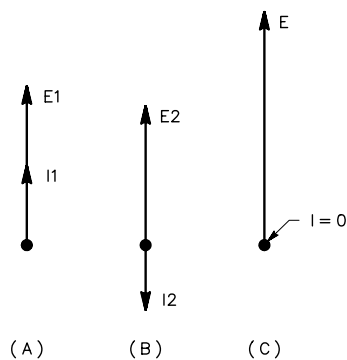


Fig 8—Voltage and current at the short circuit on a short-circuited line. These vectors show how the outgoing voltage and current (A) combine with the reflected voltage and current (B) to result in high current and very low voltage in the short circuit (C).



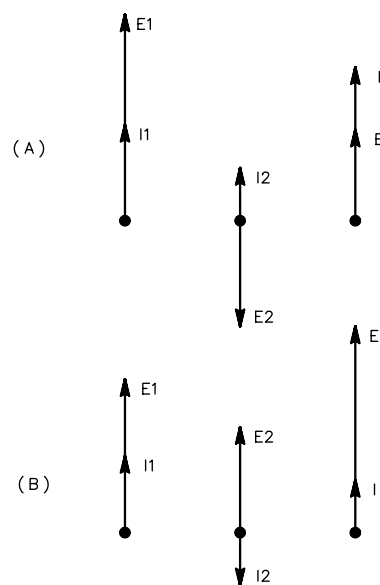


**Fig 9—Voltage and current at the end of an open-circuited line. At A, outgoing voltage and current; At B, reflected voltage and current; At C, resultant.**

Where there is a finite value of resistance (or a combination of resistance and reactance) at the end of the line, as in Fig 7A, only part of the power reaching the end of the line is reflected. That is, the reflected voltage and current are smaller than the incident voltage and current. If  $R$  is less than  $Z_0$ , the reflected and incident voltage are  $180^\circ$  out of phase, just as in the case of the short-circuited line, but the amplitudes are not equal because all of the voltage does not disappear at  $R$ . Similarly, if  $R$  is greater than  $Z_0$ , the reflected and incident currents are  $180^\circ$  out of phase (as they were in the open-circuited line), but all of the current does not appear in  $R$ . The amplitudes of the two components are therefore not equal. These two cases are shown in Fig 10. Note that the resultant current and voltage are in phase in  $R$ , because  $R$  is a pure resistance.

### Nonresistive Terminations

In most of the preceding discussions, we considered loads containing only resistance. Furthermore, our transmission line was considered to be lossless. Such a resistive load will consume some, if not all, of the power that has been transferred along the line. However, a nonresistive load such as a pure reactance can also terminate a length of line. Such terminations, of course, will consume no power,



**Fig 10—Incident and reflected components of voltage and current when the line is terminated in a pure resistance not equal to  $Z_0$ . In the case shown, the reflected components have half the amplitude of the incident components. At A,  $R$  less than  $Z_0$ ; at B,  $R$  greater than  $Z_0$ .**

but will reflect all of the energy arriving at the end of the line. In this case the theoretical SWR (covered later) in the line will be infinite, but in practice, losses in the line will limit the SWR to some finite value at line positions back toward the source.

At first you might think there is little or no point in terminating a line with a nonresistive load. In a later section we shall examine this in more detail, but the value of input impedance depends on the value of the load impedance, on the length of the line, the losses in a practical line, and on the characteristic impedance of the line. There are times when a line terminated in a nonresistive load can be used to advantage, such as in phasing or matching applications. Remote switching of reactive terminations on sections of line can be used to reverse the beam heading of an antenna array, for example. The point of this brief discussion is that a line need not always be terminated in a load that will consume power.

## Losses in Practical Transmission Lines

### ATTENUATION

Every practical line will have some inherent loss, partly because of the resistance of the conductors, partly because power is consumed in the dielectric used for insulating the conductors, and partly because in many cases a small amount of power escapes from the line by radiation. We shall consider here in detail the losses associated with conductor and dielectric losses.

### Matched-Line Losses

Power lost in a transmission line is not directly proportional to the line length, but varies logarithmically with the length. That is, if 10% of the input power is lost in a section of line of certain length, 10% of the remaining power will be lost in the next section of the same length, and so on. For this reason it is customary to express line losses in terms of decibels per unit length, since the decibel

is a logarithmic unit. Calculations are very simple because the total loss in a line is found by multiplying the decibel loss per unit length by the total length of the line.

The power lost in a matched line (that is, where the load is equal to the characteristic impedance of the line) is called *matched-line loss*. Matched-line loss is usually expressed in decibels per 100 feet. It is necessary to specify the frequency for which the loss applies, because the loss does vary with frequency.

Conductor and dielectric loss both increase as the operating frequency is increased, but not in the same way. This, together with the fact that the relative amount of each type of loss depends on the actual construction of the line, makes it impossible to give a specific relationship between loss and frequency that will apply to all types of lines. Each line must be considered individually. Actual loss values for practical lines are given in a later section of this chapter.

One effect of matched-line loss in a real transmission line is that the characteristic impedance,  $Z_0$ , becomes complex, with a non-zero reactive component  $X_0$ . Thus,

$$Z_0 = R_0 - jX_0 \quad (\text{Eq 3})$$

$$X_0 = -R_0 \frac{\alpha}{\beta} \quad (\text{Eq 4})$$

where

$$\alpha = \frac{\text{Attenuation (dB/100 feet)} \times 0.1151 (\text{nepers/dB})}{100 \text{ feet}}$$

the matched-line attenuation, in nepers per unit length

$$\beta = \frac{2\pi}{\lambda}$$

the phase constant in radians/unit length.

The reactive portion of the complex characteristic impedance is always capacitive (that is, its sign is negative) and the value of  $X_0$  is usually small compared to the resistive portion  $R_0$ .

## REFLECTION COEFFICIENT

The ratio of the reflected voltage at a given point on a transmission line to the incident voltage is called the *voltage reflection coefficient*. The voltage reflection coefficient is also equal to the ratio of the incident and reflected currents. Thus

$$\rho = \frac{E_r}{E_f} = \frac{I_r}{I_f} \quad (\text{Eq 5})$$

where

- $\rho$  = reflection coefficient
- $E_r$  = reflected voltage
- $E_f$  = forward (incident) voltage
- $I_r$  = reflected current
- $I_f$  = forward (incident) current

The reflection coefficient is determined by the relationship between the line  $Z_0$  and the actual load at the

terminated end of the line. In most cases, the actual load is not entirely resistive—that is, the load is a complex impedance, consisting of a resistance in series with a reactance, as is the complex characteristic impedance of the transmission line.

The reflection coefficient is thus a complex quantity, having both amplitude and phase, and is generally designated by the Greek letter  $\rho$  (rho), or sometimes in the professional literature as  $\Gamma$  (Gamma). The relationship between  $R_a$  (the load resistance),  $X_a$  (the load reactance),  $Z_0$  (the complex line characteristic impedance, whose real part is  $R_0$  and whose reactive part is  $X_0$ ) and the complex reflection coefficient  $\rho$  is

$$\rho = \frac{Z_a - Z_0^*}{Z_a + Z_0} = \frac{(R_a \pm jX_a) - (R_0 \mp jX_0)}{(R_a \pm jX_a) + (R_0 \pm jX_0)} \quad (\text{Eq 6})$$

Note that the sign for the  $X_0$  term in the numerator of Eq 6 is inverted from that for the denominator, meaning that the complex conjugate of  $Z_0$  is actually used in the numerator.

For high-quality, low-loss transmission lines at low frequencies, the characteristic impedance  $Z_0$  is almost completely resistive, meaning that  $Z_0 \cong R_0$  and  $X_0 \cong 0$ . The magnitude of the complex reflection coefficient in Eq 6 then simplifies to:

$$|\rho| = \frac{\sqrt{(R_a - R_0)^2 + X_a^2}}{\sqrt{(R_a + R_0)^2 + X_a^2}} \quad (\text{Eq 7})$$

For example, if the characteristic impedance of a coaxial line at a low operating frequency is  $50 \Omega$  and the load impedance is  $140 \Omega$  in series with a capacitive reactance of  $-190 \Omega$ , the magnitude of the reflection coefficient is

$$|\rho| = \frac{\sqrt{(50 - 140)^2 + (-190)^2}}{\sqrt{(50 + 140)^2 + (-190)^2}} = 0.782$$

Note that the vertical bars on each side of  $\rho$  mean the *magnitude* of rho. If  $R_a$  in Eq 7 is equal to  $R_0$  and if  $X_a$  is 0, the reflection coefficient,  $\rho$ , also is 0. This represents a matched condition, where all the energy in the incident wave is transferred to the load. On the other hand, if  $R_a$  is 0, meaning that the load has no real resistive part, the reflection coefficient is 1.0, regardless of the value of  $R_0$ . This means that all the forward power is reflected, since the load is completely reactive. As we shall see later on, the concept of reflection coefficient is a very useful one to evaluate the impedance seen looking into the input of a mismatched transmission line.

## STANDING WAVES

As might be expected, reflection cannot occur at the load without some effect on the voltages and currents all along the line. To keep things simple for a while longer, let us continue to consider only resistive loads, without any reactance. The conclusions we shall reach are valid for

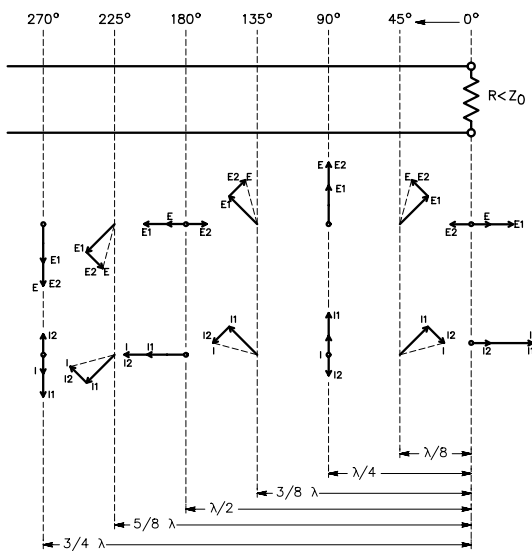
transmission lines terminated in complex impedances as well.

The effects are most simply shown by vector diagrams.

**Fig 11** is an example where the terminating resistance  $R$  is less than  $Z_0$ . The voltage and current vectors at  $R$  are shown in the reference position; they correspond with the vectors in **Fig 10A**, turned  $90^\circ$ . Back along the line from  $R$  toward the power source, the incident vectors,  $E_1$  and  $I_1$ , lead the vectors at the load according to their position along the line measured in electrical degrees. (The corresponding distances in fractions of a wavelength are also shown.) The vectors representing reflected voltage and current,  $E_2$  and  $I_2$ , successively lag the same vectors at the load.

This lag is the natural consequence of the direction in which the incident and reflected components are traveling, together with the fact that it takes time for power to be transferred along the line. The resultant voltage  $E$  and current  $I$  at each of these positions are shown as dotted arrows. Although the incident and reflected components maintain their respective amplitudes (the reflected component is shown at half the incident-component amplitude in this drawing), their phase relationships vary with position along the line. The phase shifts cause both the amplitude and phase of the *resultants* to vary with position on the line.

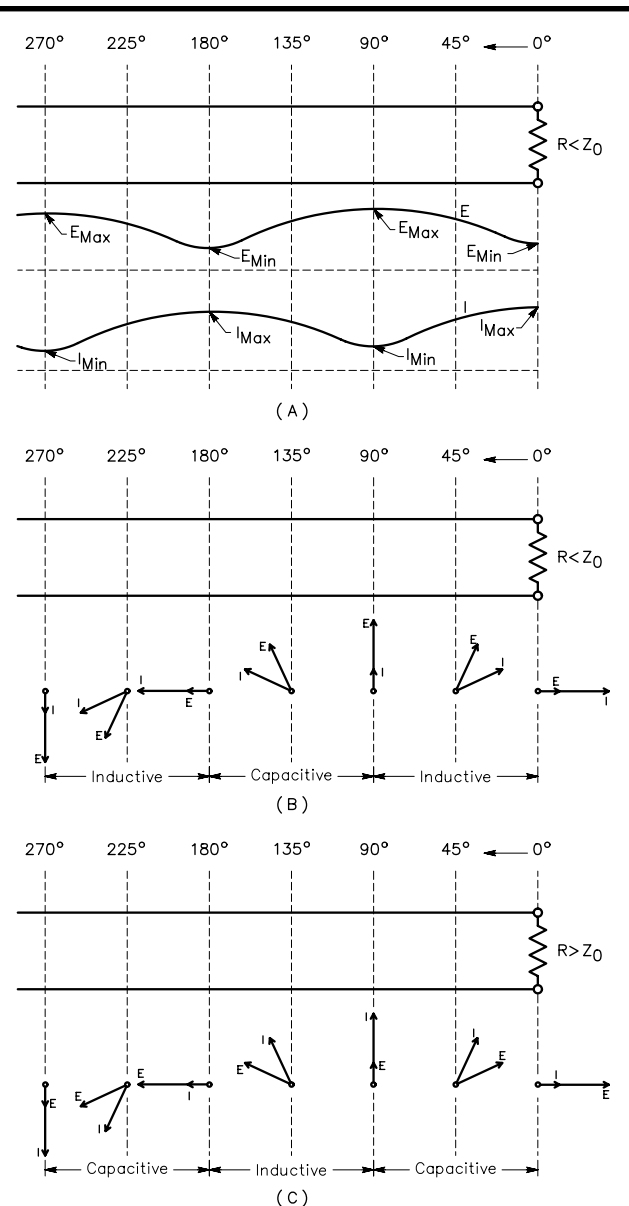
If the amplitude variations (disregarding phase) of the resultant voltage and current are plotted against position along the line, graphs like those of **Fig 12A** will result. If we could go along the line with a voltmeter and ammeter measuring the current and voltage at each point, plotting the collected data would give curves like these. In contrast, if the load matched the  $Z_0$  of the line, similar measurements along the line would show that the voltage is the same everywhere



**Fig 11**—Incident and reflected components at various positions along the transmission line, together with resultant voltages and currents at the same positions. The case shown is for  $R$  less than  $Z_0$ .

(and similarly for the current). The mismatch between load and line is responsible for the variations in amplitude which, because of their stationary, wave-like appearance, are called *standing waves*.

Some general conclusions can be drawn from inspection of the standing-wave curves: At a position  $180^\circ$  ( $\lambda/2$ ) from the load, the voltage and current have the same values they do at the load. At a position  $90^\circ$  from the load, the voltage and current are “inverted.” That is, if the voltage is lowest and current highest at the load (when  $R$  is less than  $Z_0$ ), then  $90^\circ$  from the load the voltage reaches its highest value. The current reaches its lowest value at the same point. In the case where  $R$  is greater than  $Z_0$ , so the voltage is



**Fig 12**—Standing waves of current and voltage along the line for  $R$  less than  $Z_0$ . At **A**, resultant voltages and currents along a mismatched line are shown at **B** and **C**. At **B**,  $R$  less than  $Z_0$ ; at **C**,  $R$  greater than  $Z_0$ .

highest and the current lowest at the load, the voltage is lowest and the current is highest 90° from the load.

Note that the conditions at the 90° point also exist at the 270° point (3λ/4). If the graph were continued on toward the source of power it would be found that this duplication occurs at every point that is an odd multiple of 90° (odd multiple of λ/4) from the load. Similarly, the voltage and current are the same at every point that is a multiple of 180° (any multiple of λ/2) away from the load.

### Standing-Wave Ratio

The ratio of the maximum voltage (resulting from the interaction of incident and reflected voltages along the line) to the minimum voltage—that is, the ratio of  $E_{\max}$  to  $E_{\min}$  in Fig 12A, is defined as the *voltage standing-wave ratio* (VSWR) or simply *standing-wave ratio* (SWR).

$$\text{SWR} = \frac{E_{\max}}{E_{\min}} = \frac{I_{\max}}{I_{\min}} \quad (\text{Eq 8})$$

The ratio of the maximum current to the minimum current is the same as the VSWR, so either current or voltage can be measured to determine the standing-wave ratio. The standing-wave ratio is an index of many of the properties of a mismatched line. It can be measured with fairly simple equipment, so it is a convenient quantity to use in making calculations on line performance.

The SWR is related to the magnitude of the complex reflection coefficient by

$$\text{SWR} = \frac{1 + |\rho|}{1 - |\rho|} \quad (\text{Eq 9})$$

and conversely the reflection coefficient magnitude may be defined from a measurement of SWR as

$$|\rho| = \frac{\text{SWR} - 1}{\text{SWR} + 1} \quad (\text{Eq 10})$$

We may also express the reflection coefficient in terms of forward and reflected power, quantities which can be easily measured using a directional RF wattmeter. The reflection coefficient may be computed as

$$\rho = \sqrt{\frac{P_r}{P_f}} \quad (\text{Eq 11})$$

where

$P_r$  = power in the reflected wave  
 $P_f$  = power in the forward wave.

From Eq 10, SWR is related to the forward and reflected power by

$$\text{SWR} = \frac{1 + |\rho|}{1 - |\rho|} = \frac{1 + \sqrt{P_r/P_f}}{1 - \sqrt{P_r/P_f}} \quad (\text{Eq 12})$$

Fig 13 converts Eq 12 into a convenient nomograph. In the simple case where the load contains no reactance, the

SWR is numerically equal to the ratio between the load resistance  $R$  and the characteristic impedance of the line. When  $R$  is greater than  $Z_0$ ,

$$\text{SWR} = \frac{R}{Z_0} \quad (\text{Eq 13})$$

When  $R$  is less than  $Z_0$ ,

$$\text{SWR} = \frac{Z_0}{R} \quad (\text{Eq 14})$$

(The smaller quantity is always used in the denominator of the fraction so the ratio will be a number greater than 1).

### Flat Lines

As discussed earlier, all the power that is transferred along a transmission line is absorbed in the load if that load is a resistance value equal to the  $Z_0$  of the line. In this case, the line is said to be *perfectly matched*. None of the power is reflected back toward the source. As a result, no standing waves of current or voltage will be developed along the line. For a line operating in this condition, the waveforms drawn in Fig 12A become straight lines, representing the voltage and current delivered by the source. The voltage along the line is constant, so the minimum value is the same as the maximum value. The voltage standing-wave ratio is therefore 1:1. Because a plot of the voltage standing wave is a straight line, the matched line is also said to be *flat*.

### ADDITIONAL POWER LOSS DUE TO SWR

The power lost in a given line is least when the line is terminated in a resistance equal to its characteristic impedance, and as stated previously, that is called the *matched-line loss*. There is however an *additional loss* that increases with an increase in the SWR. This is because the effective values of both current and voltage become greater on a lines with standing waves. The increase in effective current raises the ohmic losses ( $I^2R$ ) in the conductors, and the increase in effective voltage increases the losses in the dielectric ( $E^2R$ ).

The increased loss caused by an SWR greater than 1:1 may or may not be serious. If the SWR at the load is not greater than 2:1, the additional loss caused by the standing waves, as compared with the loss when the line is perfectly matched, does not amount to more than about 1/2 dB, even on very long lines. One-half dB is an undetectable change in signal strength. Therefore, it can be said that, from a practical standpoint in the HF bands, an SWR of 2:1 or less is every bit as good as a perfect match, so far as additional losses due to SWR are concerned.

However, above 30 MHz, in the VHF and especially the UHF range, where low receiver noise figures are essential for effective weak-signal work, matched-line losses for commonly available types of coax can be relatively high. This means that even a slight mismatch may become a concern regarding overall transmission line losses. At UHF one-half dB of additional loss may be considered intolerable!

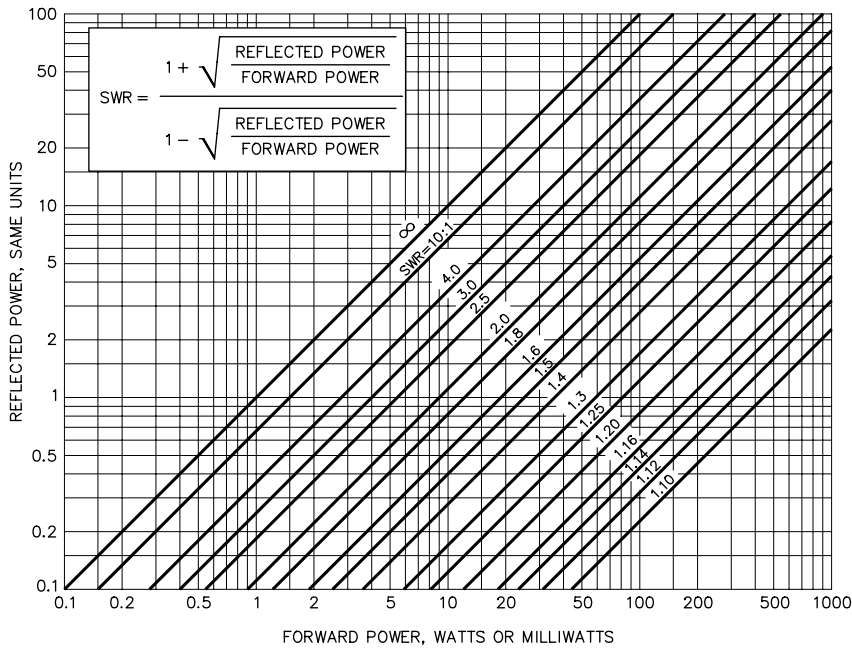


Fig 13—SWR as a function of forward and reflected power.

The total loss in a line, including matched-line and the additional loss due to standing waves may be calculated from Eq 15 below for moderate levels of SWR (less than 20:1).

$$\text{Total Loss (dB)} = 10 \log \left( \frac{a^2 - |\rho|^2}{a(1 - |\rho|^2)} \right) \quad (\text{Eq 15})$$

where

$$a = 10^{\text{ML}/10} = \text{matched-line loss ratio}$$

where

ML = the matched-line loss for particular length of line, in dB

SWR = SWR at load end of line

Thus, the additional loss caused by the standing waves is calculated from:

$$\text{Additional loss (dB)} = \text{Total Loss} - \text{ML} \quad (\text{Eq 16})$$

For example, RG-213 coax at 14.2 MHz is rated at 0.795 dB of matched-line loss per 100 feet. A 150 foot length of RG-213 would have an overall matched-line loss of

$$(0.795 / 100) \times 150 = 1.193 \text{ dB}$$

Thus, if the SWR at the load end of the RG-213 is 4:1,

$$\alpha = 10^{1.193/10} = 1.316$$

$$|\rho| = \frac{4 - 1}{4 + 1} = 0.600$$

and the total line loss

$$= 10 \log \left( \frac{1.316^2 - 0.600^2}{1.316(1 - 0.600^2)} \right) = 2.12 \text{ dB.}$$

The additional loss due to the SWR of 4:1 is  $2.12 - 1.19 = 0.93$  dB. Fig 14 is a graph of additional loss versus SWR.

### LINE VOLTAGES AND CURRENTS

It is often desirable to know the voltages and currents that are developed in a line operating with standing waves. The voltage maximum may be calculated from Eq 17 below, and the other values determined from the result.

$$E_{\text{max}} = \sqrt{P \times Z_0 \times \text{SWR}} \quad (\text{Eq 17})$$

where

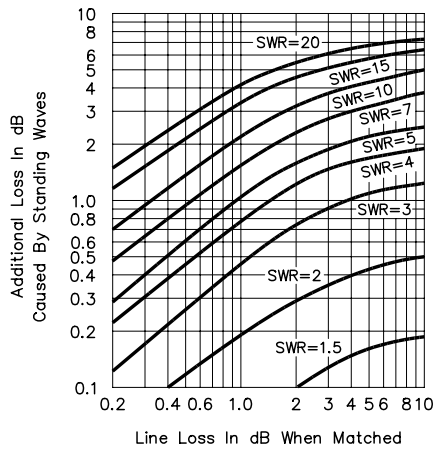
$E_{\text{max}}$  = voltage maximum along the line in the presence of standing waves

P = power delivered by the source to the line input, watts

$Z_0$  = characteristic impedance of the line, ohms

SWR = SWR at the load

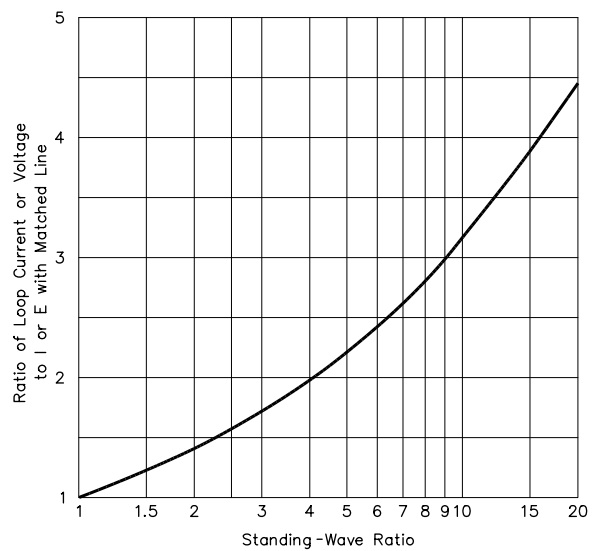
If 100 W of power is applied to a 600  $\Omega$  line with an SWR at the load of 10:1,  $E_{\text{max}} = \sqrt{100 \times 600 \times 10} = 774.6$  V. Based on Eq 8,  $E_{\text{min}}$ , the minimum voltage along the line equals  $E_{\text{max}}/\text{SWR} = 774.6/10 = 77.5$  V. The maximum current may be found by using Ohm's Law.  $I_{\text{max}} = E_{\text{max}}/Z_0 = 774.6/600 = 1.29$  A. The minimum current equals  $I_{\text{max}}/\text{SWR} = 1.29/10 = 0.129$  A.



**Fig 14—Additional line loss due to standing waves (SWR, measured at the load). See Fig 23 for matched-line loss. To determine the total loss in dB, add the matched-line loss to the value from this graph.**

The voltage determined from Eq 17 is the RMS value—that is, the voltage that would be measured with an ordinary RF voltmeter. If voltage breakdown is a consideration, the value from Eq 17 should be converted to an *instantaneous peak voltage*. Do this by multiplying times  $\sqrt{2}$  (assuming the RF waveform is a sine wave). Thus, the maximum instantaneous peak voltage in the above example is  $774.6 \times \sqrt{2} = 1095.4\text{V}$ .

Strictly speaking, the values obtained as above apply only near the load in the case of lines with appreciable losses. However, the resultant values are the maximum possible that can exist along the line, whether there are line losses or not. For this reason they are useful in determining whether or



**Fig 15—Increase in maximum value of current or voltage on a line with standing waves, as referred to the current or voltage on a perfectly matched line, for the same power delivered to the load. Voltage and current at minimum points are given by the reciprocals of the values along the vertical axis. The curve is plotted from the relationship, current (or voltage) ratio = the square root of SWR.**

not a particular line can operate safely with a given SWR. Voltage ratings for various cable types are given in a later section.

Fig 15 shows the ratio of current or voltage at a loop, in the presence of standing waves, to the current or voltage that would exist with the same power in a perfectly matched line. As with Eq 17 and related calculations, the curve literally applies only near the load.

## Input Impedance

The effects of incident and reflected voltage and current along a mismatched transmission line can be difficult to envision, particularly when the load at the end of the transmission line is not purely resistive, and when the line is not perfectly lossless.

If we can put aside for a moment all the complexities of reflections, SWR and line losses, a transmission line can simply be considered to be an *impedance transformer*. A certain value of load impedance, consisting of a resistance and reactance, at the end of a particular transmission line is transformed into another value of impedance at the input of the line. The amount of transformation is determined by the electrical length of the line, its characteristic impedance, and by the losses inherent in the line. The input impedance of a real, lossy transmission line is computed using the following equation, called the *Transmission Line Equation*

$$Z_{in} = Z_0 \frac{Z_L \cosh(\gamma\ell) + Z_0 \sinh(\gamma\ell)}{Z_L \sinh(\gamma\ell) + Z_0 \cosh(\gamma\ell)} \quad (\text{Eq 18})$$

where

$Z_{in}$  = complex impedance at input of line

$Z_L$  = complex load impedance at end of line =  $R_a + j X_a$

$Z_0$  = characteristic impedance of line =  $R_0 - j X_0$

$\ell$  = physical length of line

$\gamma$  = complex loss coefficient =  $\alpha + j \beta$

$\alpha$  = matched-line loss attenuation constant, in nepers/unit length (1 neper = 8.688 dB; cables are rated in dB/100 ft)

$\beta$  = phase constant of line in radians/unit length (related to physical length of line  $\ell$  by the fact that  $2\pi$  radians = one wavelength, and by Eq 2)

$$\beta = \frac{2\pi}{VF \times 983.6/f(\text{MHz})} \text{ for } \ell \text{ in feet}$$

VF = velocity factor

For example, assume that a half-wave dipole terminates a 50-foot long piece of RG-213 coax. This dipole is assumed to have an impedance of  $43 + j 30 \Omega$  at 7.15 MHz, and its velocity factor is 0.66. The matched-line loss at 7.15 MHz is 0.54 dB/100 feet, and the characteristic impedance  $Z_0$  for this type of cable is  $50 - j 0.45 \Omega$ . Using Eq 18, we compute the impedance at the input of the line as  $65.8 + j 32.0 \Omega$ .

Solving this equation manually is quite tedious, but it may be solved using a traditional paper Smith Chart or a computer program. Chapter 28 details the use of the Smith Chart. *WinSmith*, a sophisticated graphical Smith Chart program written for the IBM PC, is available through ARRL. *TLW* (Transmission Line for Windows) is another ARRL program that performs this transformation, but without Smith Chart graphics. *TLW* is on the CD-ROM accompanying this edition of *The ARRL Antenna Book*.

One caution should be noted when using any of these computational tools to calculate the impedance at the input of a mismatched transmission line—the velocity factor of practical transmission lines can vary significantly between manufacturing runs of the same type of cable. For highest accuracy, you should measure the velocity factor of a particular length of cable before using it to compute the impedance at the end of the cable. See Chapter 27 for details on measurements of line characteristics.

### Series and Parallel Equivalent Circuits

Once the series-form impedance  $R_S \pm j X_S$  at the input of a particular line has been determined, either by measurement or by computation, you may wish to determine the equivalent parallel circuit  $R_P \parallel \pm j X_P$ , which is equivalent to the series form only at a single frequency. The equivalent parallel circuit is often useful when designing a matching circuit (such as an antenna tuner, for example) to transform the impedance at the input of the cable to another impedance. The following equations are used to make the transformation from series to parallel and from parallel to series. See Fig 16.

$$R_P = \frac{R_S^2 + X_S^2}{R_S} \quad (\text{Eq 19A})$$

$$X_P = \frac{R_S^2 + X_S^2}{X_S} \quad (\text{Eq 19B})$$

and

$$R_S = \frac{R_P X_P^2}{R_P^2 + X_P^2} \quad (\text{Eq 20A})$$

$$X_S = \frac{R_P^2 X_P}{R_P^2 + X_P^2} \quad (\text{Eq 20B})$$

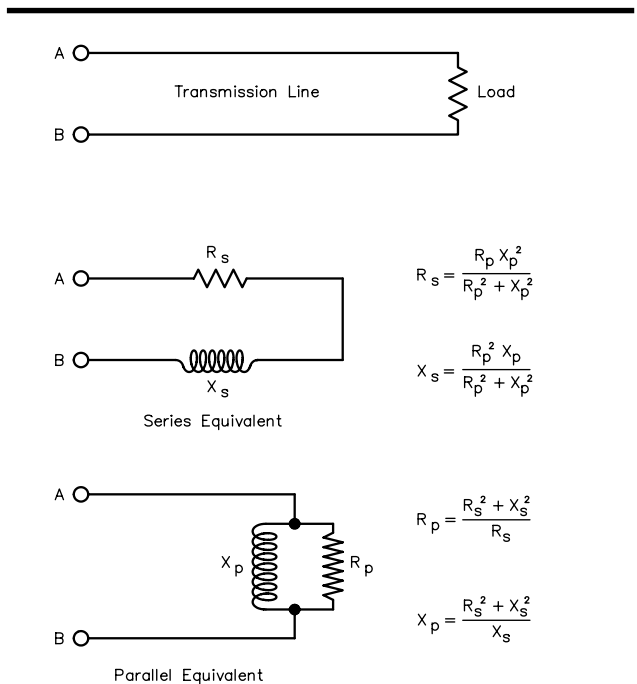
The individual values in the parallel circuit are not the same as those in the series circuit (although the overall result is the same, but only at one frequency), but are related to the series-circuit values by these equations. For example, let us continue the example in the section above, where the impedance at the input of the 50 feet of RG-213 at 7.15 MHz is  $65.8 + j 32.0 \Omega$ . The equivalent parallel circuit at 7.15 MHz is

$$R_P = \frac{65.8^2 + 32.0^2}{65.8} = 81.36 \Omega$$

$$X_P = \frac{65.8^2 + 32.0^2}{32.0} = 167.30 \Omega$$

If we were to put 100 W of power into this parallel equivalent circuit, the voltage across the parallel components would be

$$\text{Since } P = \frac{E^2}{R}, E = \sqrt{P \times R} = \sqrt{100 \times 81.36} = 90.2 \text{ V}$$



**Fig 16—Input impedance of a line terminated in a resistance. This impedance can be represented by either a resistance and reactance in series, or a resistance and reactance in parallel, at a single frequency. The relationships between the R and X values in the series and parallel equivalents are given by the equations shown. X may be either inductive or capacitive, depending on the line length,  $Z_0$  and the load impedance, which need not be purely resistive.**

Thus, the current through the inductive part of the parallel circuit would be

$$I = \frac{E}{X_p} = \frac{90.2}{167.3} = 0.54 \text{ A}$$

### Highly Reactive Loads

When highly reactive loads are used with practical transmission lines, especially coax lines, the overall loss can reach staggering levels. For example, a popular multiband antenna is a 100-foot long center-fed dipole located some 50 feet over average ground. At 1.83 MHz, such an antenna will exhibit a feed-point impedance of  $4.5 - j 1673 \Omega$ , according to the mainframe analysis program *NEC2*. The high value of capacitive reactance indicates that the antenna is extremely short electrically—after all, a half-wave dipole at 1.83 MHz is almost 270 feet long, compared to this 100 foot long antenna. If an amateur attempts to feed such a multiband antenna directly with 100 feet of RG-213 50- $\Omega$  coaxial cable, the SWR at the antenna terminals would be (using the *TLW* program) 1740:1. An SWR of more than 1700 to one is a very high level of SWR indeed! At 1.83 MHz the *matched-line loss* of 100 feet of the RG-213 coax by itself is only 0.26 dB. However, the *total line loss* due to this extreme level of SWR is 26 dB.

This means that if 100 W is fed into the input of this line, the amount of power at the antenna is reduced to only 0.25 W! Admittedly, this is an extreme case. It is more likely that an amateur would feed such a multiband antenna with open-wire *ladder* or *window* line than coaxial cable. The matched-line loss characteristics for 450- $\Omega$  window open-wire line are far better than coax, but the SWR at the end of this line is still 793:1, resulting in an overall loss of 8.9 dB. Even for low-loss open-wire line, the total loss is significant because of the extreme SWR.

This means that only about 13% of the power from the transmitter is getting to the antenna, and although this is not very desirable, it is a lot better than the losses in coax cable feeding the same antenna. However, at a transmitter power level of 1500 W, the maximum voltage in a typical antenna tuner used to match this line impedance is almost 9200V with the open-wire line, a level which will certainly cause arcing or burning inside. (As a small compensation for all the loss in coax under this extreme condition, so much power is lost that the voltages present in the antenna tuner are not excessive.) Keep in mind also that an antenna tuner can lose significant power in internal losses for very high impedance levels, even if it has sufficient range to match such impedances in the first place.

Clearly, it would be far better to use a longer antenna at this 160-meter frequency. Another alternative would be to resonate a short antenna with loading coils (at the antenna). Either strategy would help avoid excessive feed line loss, even with low-loss line.

## SPECIAL CASES

Beside the primary purpose of transporting power from one point to another, transmission lines have properties that are useful in a variety of ways. One such special case is a line an exact multiple of  $\lambda/4$  ( $90^\circ$ ) long. As shown earlier, such a line will have a purely resistive input impedance when the termination is a pure resistance. Also, short-circuited or open-circuited lines can be used in place of conventional inductors and capacitors since such lines have an input impedance that is substantially a pure reactance when the line losses are low.

### The Half-Wavelength Line

When the line length is an even multiple of  $180^\circ$  (that is, a multiple of  $\lambda/2$ ), the input resistance is equal to the load resistance, regardless of the line  $Z_0$ . As a matter of fact, a line an exact multiple of  $\lambda/2$  in length (disregarding line losses) simply repeats, at its input or sending end, whatever impedance exists at its output or receiving end. It does not matter whether the impedance at the receiving end is resistive, reactive, or a combination of both. Sections of line having such length can be added or removed without changing any of the operating conditions, at least when the losses in the line itself are negligible.

### Impedance Transformation with Quarter-Wave Lines

The input impedance of a line an odd multiple of  $\lambda/4$  long is

$$Z_i = \frac{Z_0^2}{Z_L} \quad (\text{Eq 21})$$

where  $Z_i$  is the input impedance and  $Z_L$  is the load impedance. If  $Z_L$  is a pure resistance,  $Z_i$  will also be a pure resistance. Rearranging this equation gives

$$Z_0 = \sqrt{Z_i Z_L} \quad (\text{Eq 22})$$

This means that if we have two values of impedance what we wish to “match,” we can do so if we connect them together by a  $\lambda/4$  transmission line having a characteristic impedance equal to the square root of their product.

A  $\lambda/4$  line is, in effect, a transformer, and in fact is often referred to as a *quarter-wave transformer*. It is frequently used as such in antenna work when it is desired, for example, to transform the impedance of an antenna to a new value that will match a given transmission line. This subject is considered in greater detail in a later chapter.

### Lines as Circuit Elements

Two types of nonresistive line terminations are quite useful—short and open circuits. The impedance of the short-circuit termination is  $0 + j0$ , and the impedance of the open-circuit termination is infinite. Such terminations are used in *stub matching*. (See Chapters 26 and 28.) An open- or short-



circuited line does not deliver any power to a load, and for that reason is not, strictly speaking a “transmission” line. However, the fact that a line of the proper length has inductive reactance makes it possible to substitute the line for a coil in an ordinary circuit. Likewise, another line of appropriate length having capacitive reactance can be substituted for a capacitor.

Sections of lines used as circuit elements are usually  $\lambda/4$  or less long. The desired type of reactance (inductive or capacitive) or the desired type of resonance (series or parallel) is obtained by shorting or opening the far end of the line. The circuit equivalents of various types of line sections are shown in Fig 17.

When a line section is used as a reactance, the amount of reactance is determined by the characteristic impedance and the electrical length of the line. The type of reactance exhibited at the input terminals of a line of given length depends on whether it is open- or short-circuited at the far end.

The equivalent *lumped* value for any inductor or capacitor may be determined with the aid of the Smith Chart or Eq 18. Line losses may be taken into account if desired, as explained for Eq 18. In the case of a line having no losses, and to a close approximation when the losses are small, the inductive reactance of a short-circuited line less than  $\lambda/4$  in length is

$$X_L \text{ in } \Omega = Z_0 \tan \ell \quad (\text{Eq 23})$$

where  $\ell$  is the length of the line in electrical degrees and  $Z_0$  is the characteristic impedance of the line.

The capacitive reactance of an open-circuited line less than  $\lambda/4$  in length is

$$X_C \text{ in } \Omega = Z_0 \cot \ell \quad (\text{Eq 24})$$

Lengths of line that are exact multiples of  $\lambda/4$  have the properties of resonant circuits. With an open-circuit termination, the input impedance of the line acts like a series-resonant circuit. With a short-circuit termination, the line input

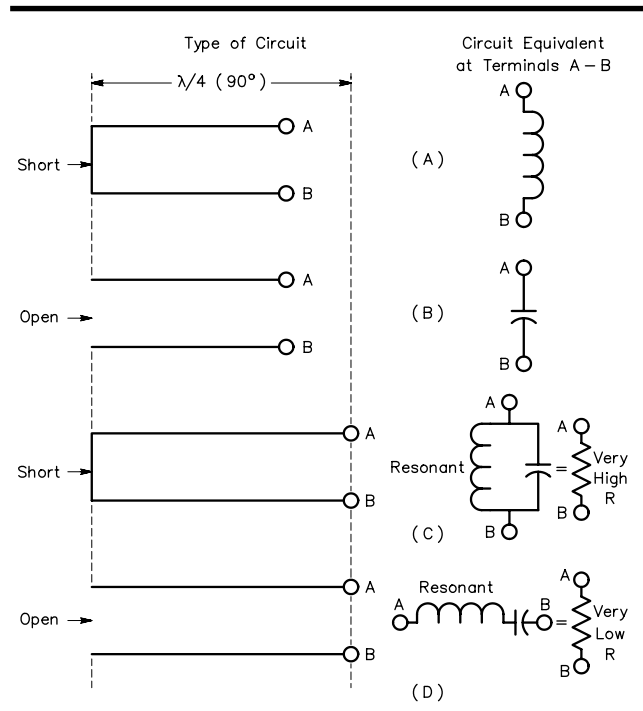


Fig 17—Lumped-constant circuit equivalents of open- and short-circuited transmission lines.

simulates a parallel-resonant circuit. The effective Q of such linear resonant circuits is very high if the line losses, both in resistance and by radiation, are kept down. This can be done without much difficulty, particularly in coaxial lines, if air insulation is used between the conductors. Air-insulated open-wire lines are likewise very good at frequencies for which the conductor spacing is very small in terms of wavelength.

Applications of line sections as circuit elements in connection with antenna and transmission-line systems are discussed in later chapters.

## Line Construction and Operating Characteristics

The two basic types of transmission lines, parallel conductor and coaxial, can be constructed in a variety of forms. Both types can be divided into two classes, (1) those in which the majority of the insulation between the conductors is air, where only the minimum of solid dielectric necessary for mechanical support is used, and (2) those in which the conductors are embedded in and separated by a solid dielectric. The first variety (air insulated) has the lowest loss per unit length, because there is no power loss in dry air if the voltage between conductors is below the value at which corona forms. At the maximum power permitted in amateur transmitters, it is seldom necessary to consider corona unless the SWR on the line is very high.

### AIR-INSULATED LINES

A typical construction technique used for parallel conductor or “two wire” air-insulated transmission lines is shown in Fig 18. The two wires are supported a fixed distance apart by means of insulating rods called *spacers*. Spacers may be made from material such as Teflon, Plexiglas, phenolic, polystyrene, plastic clothespins or plastic hair curlers. Materials commonly used in high quality spacers are isolantite, Lucite and polystyrene. (Teflon is generally not used because of its higher cost.) The spacer length varies from 2 to 6 inches. The smaller spacings are desirable at the higher frequencies (28 MHz) so radiation from the transmission line is minimized.

Spacers must be used at small enough intervals along the line to keep the two wires from moving appreciably with respect to each other. For amateur purposes, lines using this construction ordinarily have #12 or #14 conductors, and the characteristic impedance is between 500 to 600 Ω. Although once used nearly exclusively, such homemade lines are enjoying a renaissance of sorts because of their high efficiency and low cost.

Where an air insulated line with still lower characteristic impedance is needed, metal tubing from 1/4 to 1/2-inch diameter is frequently used. With the larger conductor diameter and relatively close spacing, it is possible to build a line having a characteristic impedance as low as about 200 Ω. This construction technique is principally used for λ/4 matching transformers at the higher frequencies.

The characteristic impedance of an air insulated parallel conductor line, neglecting the effect of the spacers, is given by

$$Z_0 = 276 \log \frac{2S}{d} \quad (\text{Eq 25})$$

where

$Z_0$  = characteristic impedance in ohms

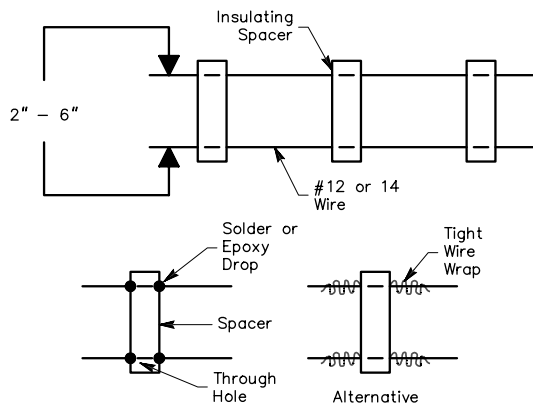
$S$  = center-to-center distance between conductors

$d$  = outer diameter of conductor (in the same units as  $S$ )

Impedances for common sizes of conductors over a range of spacings are given in **Fig 19**.

### Four-Wire Lines

Another parallel conductor line that is useful in some applications is the four-wire line (**Fig 20C**). In cross section, the conductors of the four-wire line are at the corners of a square. Spacings are on the same order as those used in two-wire lines. The conductors at opposite corners of the square are connected to operate in parallel. This type of line has a



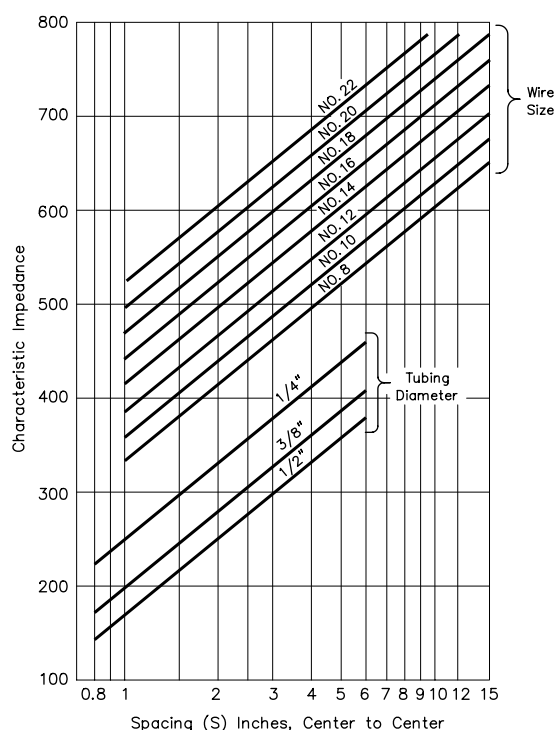
**Fig 18**—Typical open-wire line construction. The spacers may be held in place by beads of solder or epoxy cement. Wire wraps can also be used, as shown.

lower characteristic impedance than the simple two-wire type. Also, because of the more symmetrical construction, it has better electrical balance to ground and other objects that are close to the line. The spacers for a four-wire line may be discs of insulating material, X-shaped members, etc.

### Air-Insulated Coaxial Lines

In air-insulated coaxial lines (**Fig 20D**), a considerable proportion of the insulation between conductors may actually be a solid dielectric, because the separation between the inner and outer conductors must be constant. This is particularly likely to be true in small diameter lines. The inner conductor, usually a solid copper wire, is supported at the center of the copper tubing outer conductor by insulating beads or a helically wound strip of insulating material. The beads usually are isolantite, and the wire is generally crimped on each side of each bead to prevent the beads from sliding. The material of which the beads are made, and the number of beads per unit length of line, will affect the characteristic impedance of the line. The greater the number of beads in a given length, the lower the characteristic impedance compared with the value obtained with air insulation only. Teflon is ordinarily used as a helically wound support for the center conductor. A tighter helical winding lowers the characteristic impedance.

The presence of the solid dielectric also increases the



**Fig 19**—Characteristic impedance as a function of conductor spacing and size for parallel conductor lines.

losses in the line. On the whole, however, a coaxial line of this type tends to have lower actual loss, at frequencies up to about 100 MHz, than any other line construction, provided the air inside the line can be kept dry. This usually means that air-tight seals must be used at the ends of the line and at every joint. The characteristic impedance of an air-insulated coaxial line is given by

$$Z_0 = 138 \log \frac{D}{d} \quad (\text{Eq 26})$$

where

- $Z_0$  = characteristic impedance in ohms
- D = inside diameter of outer conductor
- d = outside diameter of inner conductor (in same units as D)

Values for typical conductor sizes are graphed in Fig 21. The equation and the graph for coaxial lines are approximately correct for lines in which bead spacers are used, provided the beads are not too closely spaced.

### FLEXIBLE LINES

Transmission lines in which the conductors are separated by a flexible dielectric have a number of advantages over the air insulated type. They are less bulky, weigh less in comparable types and maintain more uniform spacing between conductors. They are also generally easier to install, and are neater in appearance. Both parallel conductor and coaxial lines are available with flexible insulation.

The chief disadvantage of such lines is that the power

loss per unit length is greater than in air insulated lines. Power is lost in heating of the dielectric, and if the heating is great enough (as it may be with high power and a high SWR), the line may break down mechanically and electrically.

### Parallel-Conductor Lines

The construction of a number of types of flexible line is shown in Fig 22. In the most common 300-Ω type (twin-lead), the conductors are stranded wire equivalent to #20 in cross sectional area, and are molded in the edges of a polyethylene ribbon about 1/2 inch wide that keeps the wires spaced away a constant amount from each other. The effective dielectric is partly solid and partly air, and the presence of the solid dielectric lowers the characteristic impedance of the line as compared with the same conductors in air. The resulting impedance is approximately 300 Ω.

Because part of the field between the conductors exists outside the solid dielectric, dirt and moisture on the surface of the ribbon tend to change the characteristic impedance of the line. The operation of the line is therefore affected by weather conditions. The effect will not be very serious in a line terminated in its characteristic impedance, but if there is a considerable mismatch, a small change in  $Z_0$  may cause wide fluctuations of the input impedance. Weather effects can be minimized by cleaning the line occasionally and

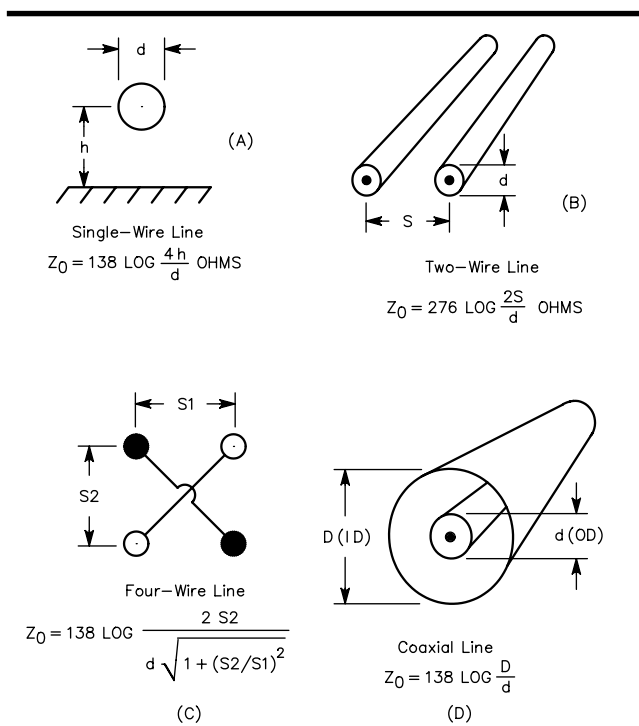


Fig 20—Construction of air insulated transmission lines.

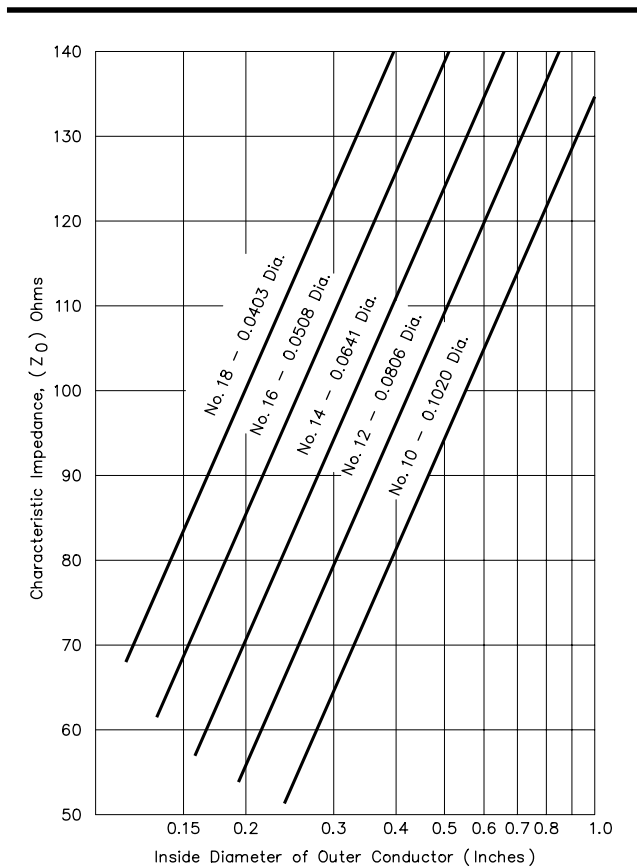
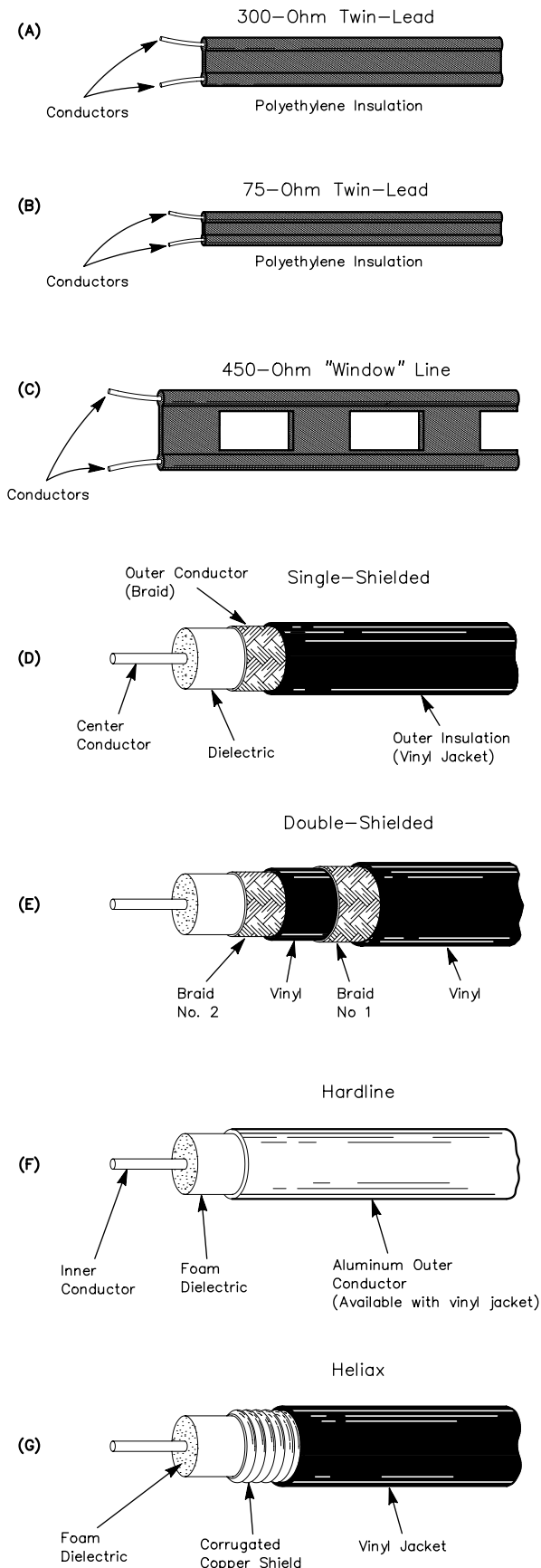


Fig 21—Characteristic impedance of typical air insulated coaxial lines.



giving it a thin coating of a water repellent material such as silicone grease or car wax.

To overcome the effects of weather on the characteristic impedance and attenuation of ribbon type line, another type of twin-lead is made using an oval polyethylene tube with an air core or a foamed dielectric core. The conductors are molded diametrically opposite each other in the walls. This increases the leakage path across the dielectric surface. Also, much of the electric field between the conductors is in the hollow (or foam-filled) center of the tube. This type of line is fairly impervious to weather effects. Care should be used when installing it, however, so any moisture that condenses on the inside with changes in temperature and humidity can drain out at the bottom end of the tube and not be trapped in one section. This type of line is made in two conductor sizes (with different tube diameters), one for receiving applications and the other for transmitting.

Transmitting type 75-Ω twin lead uses stranded conductors nearly equivalent to solid #12 wire, with quite close spacing between conductors. Because of the close spacing, most of the field is confined to the solid dielectric, with very little existing in the surrounding air. This makes the 75-Ω line much less susceptible to weather effects than the 300-Ω ribbon type.

A third type of commercial parallel-line is so-called *window line*, illustrated in Fig 22C. This is a variation of twinlead construction, except that *windows* are cut in the polyethylene insulation at regular intervals. This holds down on the weight of the line, and also breaks up the amount of surface area where dirt, dust and moisture can accumulate. Such window line is commonly available with a nominal characteristic impedance of 450 Ω, although 300-Ω line can be found also. A conductor spacing of about 1 inch is used in the 450-Ω line and 1/2 inch in the 300-Ω line. The conductor size is usually about #18. The impedances of such lines are somewhat lower than given by Fig 19 for the same conductor size and spacing, because of the effect of the dielectric constant of the spacer material used. The attenuation is quite low and lines of this type are entirely satisfactory for transmitting applications at amateur power levels.

## COAXIAL CABLES

Coaxial cable is available in flexible and semi-flexible varieties. The fundamental design is the same in all types, as shown in Fig 22. The outer diameter varies from 0.06 inch to over 5 inches. Power handling capability and cable size are directly proportional, as larger dielectric thickness and larger conductor sizes can handle higher voltages and currents. Generally, losses decrease as cable diameter increases. The extent to which this is true is dependent on

**Fig 22—Construction of flexible parallel conductor and coaxial lines with solid dielectric. A common variation of the double shielded design at E has the braids in continuous electrical contact.**

the properties of the insulating material.

Some coaxial cables have stranded wire center conductors while others use a solid copper conductor. Similarly, the outer conductor (shield) may be a single layer of copper braid, a double layer of braid (more effective shielding), solid aluminum (Hardline), aluminum foil, or a combination of these.

### Losses and Deterioration

The power handling capability and loss characteristics of coaxial cable depend largely on the dielectric material between the conductors and the size of the conductors. The commonly used cables and many of their properties are listed in **Table 1**. **Fig 23** is a graph of the matched-line attenuation characteristics versus frequency for the most popular lines. The outer insulating jacket of the cable (usually PVC) is used solely as protection from dirt, moisture and chemicals. It has no electrical function. Exposure of the inner insulating material to moisture and chemicals over time contaminates the dielectric and increases cable losses. Foam dielectric cables are less prone to contamination than are solid-

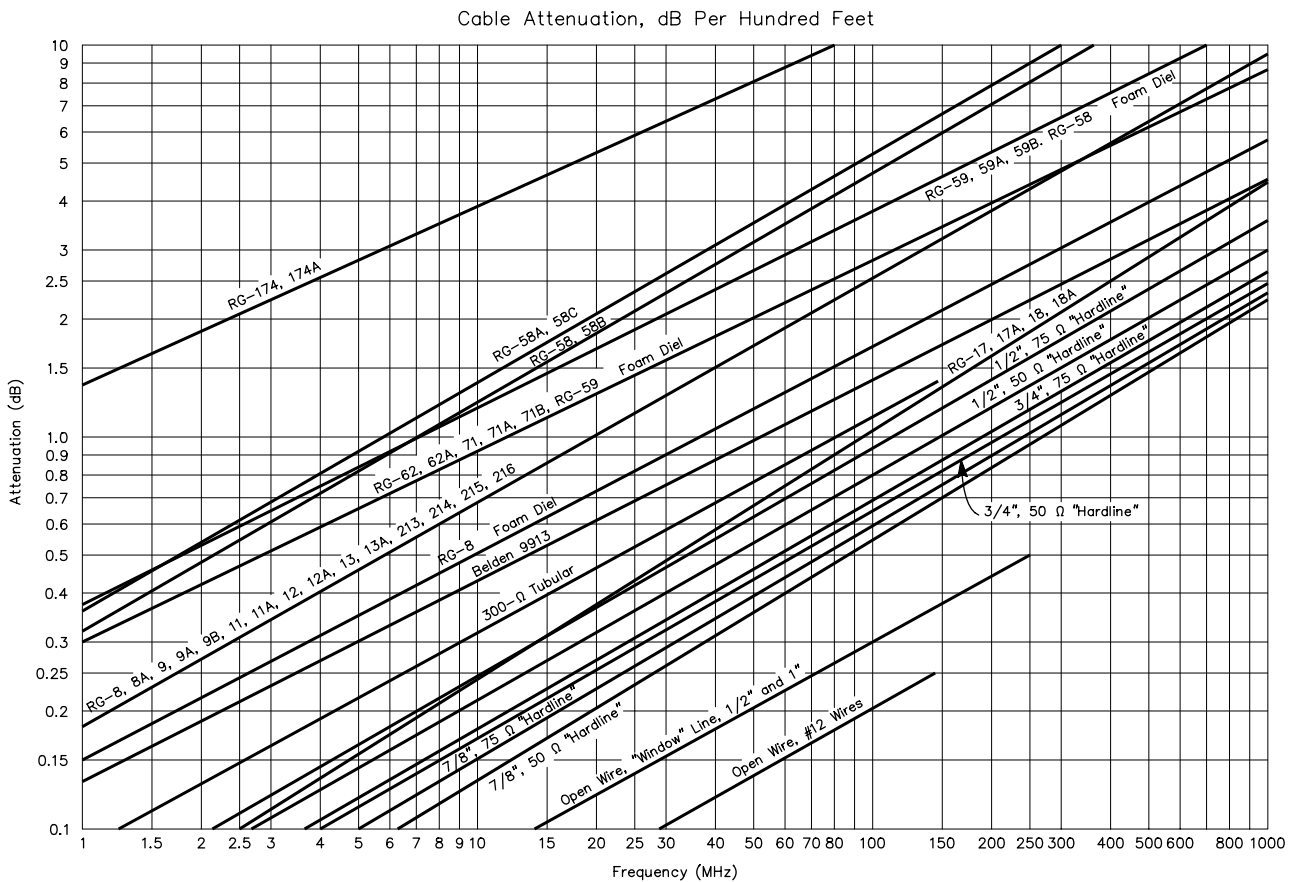
polyethylene insulated cables.

Impregnated cables, such as Decibel Products *VB-8* and Times Wire & Cable Co. *Imperveon*, are immune to water and chemical damage, and may be buried if desired. They also have a self-healing property that is valuable when rodents chew into the line. Cable loss should be checked at least every two years if the cable has been outdoors or buried. See the section on testing transmission lines.

The pertinent characteristics of unmarked coaxial cables can be determined from the equations in **Table 2**. The most common impedance values are 52, 75 and 95  $\Omega$ . However, impedances from 25 to 125  $\Omega$  are available in special types of manufactured line. The 25- $\Omega$  cable (miniature) is used extensively in magnetic-core broadband transformers.

### Cable Capacitance

The capacitance between the conductors of coaxial cable varies with the impedance and dielectric constant of the line. Therefore, the lower the impedance, the higher the capacitance per foot, because the conductor spacing is decreased. Capacitance also increases with dielectric constant.



**Fig 23—Nominal matched-line attenuation in decibels per 100 feet of various common transmission lines. Total attenuation is directly proportional to length. Attenuation will vary somewhat in actual cable samples, and generally increases with age in coaxial cables having a type 1 jacket. Cables grouped together in the above chart have approximately the same attenuation. Types having foam polyethylene dielectric have slightly lower loss than equivalent solid types, when not specifically shown above.**

**Table 1**  
**Characteristics of Commonly Used Transmission Lines**

RG or Type	Part Number	Z <sub>0</sub> Ω	VF %	Cap. pF/ft	Cent. Cond. AWG	Diel.	Shield	Jacket	OD in.	Max V (RMS)	Matched Loss (dB/100)			
											1 MHz	10	100	1000
RG-6	Belden 8215	75	66	20.5	#21 Solid	PE	FC	PE	0.275	2700	0.4	0.8	2.7	9.8
RG-8	TMS LMR400	50	85	23.9	#10 Solid	FPE	FC	PE	0.405	600	0.1	0.4	1.3	4.1
RG-8	Belden 9913	50	84	24.6	#10 Solid	ASPE	FC	P1	0.405	600	0.1	0.4	1.3	4.5
RG-8	WM CQ102	50	84	24.0	#9.5 Solid	ASPE	S	P2	0.405	600	0.1	0.4	1.3	4.5
RG-8	DRF-BF	50	84	24.5	#9.5 Solid	FPE	FC	PEBF	0.405	600	0.1	0.5	1.6	5.2
RG-8	WM CQ106	50	82	24.5	#9.5 Solid	FPE	FC	P2	0.405	600	0.2	0.6	1.8	5.3
RG-8	Belden 9914	50	82	24.8	#10 Solid	TFE	FC	P1	0.405	3700	0.1	0.5	1.6	6.0
RG-8	Belden 8237	52	66	29.5	#13 Flex	PE	S	P1	0.405	3700	0.2	0.6	1.9	7.4
RG-8X	TMS LMR240	50	84	24.2	#15 Solid	FPE	FC	PE	0.242	300	0.2	0.8	2.5	8.0
RG-8X	WM CQ118	50	82	25.0	#16 Flex	FPE	S	P2	0.242	300	0.3	0.9	2.8	8.4
RG-8X	Belden 9258	50	80	25.3	#16 Flex	TFE	S	P1	0.242	300	0.3	1.0	3.3	14.3
RG-9	Belden 8242	51	66	30.0	#13 Flex	PE	D	P2N	0.420	3700	0.2	0.6	2.1	8.2
RG-11	Belden 8213	75	78	17.3	#14 Solid	FPE	S	PE	0.405	600	0.2	0.4	1.5	5.4
RG-11	Belden 8238	75	66	20.5	#18 Flex	PE	S	P1	0.405	600	0.2	0.7	2.0	7.1
RG-58C	TMS LMR200	50	83	24.5	#17 Solid	FPE	FC	PE	0.195	300	0.3	1.0	3.2	10.5
RG-58	WM CQ124	53.5	66	28.5	#20 Solid	PE	S	P2N	0.195	1400	0.4	1.3	4.3	14.3
RG-58	Belden 8240	53.5	66	28.5	#20 Solid	PE	S	P1	0.193	1400	0.3	1.1	3.8	14.5
RG-58A	Belden 8219	50	78	26.5	#20 Flex	FPE	S	P1	0.198	300	0.4	1.3	4.5	18.1
RG-58C	Belden 8262	50	66	30.8	#20 Flex	PE	S	P2N	0.195	1400	0.4	1.4	4.9	21.5
RG-58A	Belden 8259	50	66	30.8	#20 Flex	PE	S	P1	0.193	1400	0.4	1.5	5.4	22.8
RG-59	Belden 8212	75	78	17.3	#20 Solid	TFE	S	PE	0.242	300	0.6	1.0	3.0	10.9
RG-59B	Belden 8263	75	66	20.5	#23 Solid	PE	S	P2N	0.242	1700	0.6	1.1	3.4	12.0
RG-62A	Belden 9269	93	84	13.5	#22 Solid	ASPE	S	P1	0.260	750	0.3	0.9	2.7	8.7
RG-62B	Belden 8255	93	84	13.5	#24 Solid	ASPE	S	P2N	0.260	750	0.3	0.9	2.9	11.0
RG-63B	Belden 9857	125	84	9.7	#22 Solid	ASPE	S	P2N	0.405	750	0.2	0.5	1.5	5.8
RG-142B	Belden 83242	50	69.5	29.2	#18 Solid	TFE	D	TFE	0.195	1400	0.3	1.1	3.9	13.5
RG-174	Belden 8216	50	66	30.8	#26 Solid	PE	S	P1	0.101	1100	1.9	3.3	8.4	34.0
RG-213	Belden 8267	50	66	30.8	#13 Flex	PE	S	P2N	0.405	3700	0.2	0.6	2.1	8.2
RG-214	Belden 8268	50	66	30.8	#13 Flex	PE	D	P2N	0.425	3700	0.2	0.6	1.9	8.0
RG-216	Belden 9850	75	66	20.5	#18 Flex	PE	D	P2N	0.425	3700	0.2	0.7	2.0	7.1
RG-217	M17/79-RG217	50	66	30.8	#9.5 Solid	PE	D	P2N	0.545	7000	0.1	0.4	1.4	5.2
RG-218	M17/78-RG218	50	66	29.5	#4.5 Solid	PE	S	P2N	0.870	11000	0.1	0.2	0.8	3.4
RG-223	Belden 9273	50	66	30.8	#19 Solid	PE	D	P2N	0.212	1700	0.4	1.2	4.1	14.5
RG-303	Belden 84303	50	69.5	29.2	#18 Solid	TFE	S	TFE	0.170	1400	0.3	1.1	3.9	13.5
RG-316	Belden 84316	50	69.5	29.0	#26 Solid	TFE	S	TFE	0.098	900	1.2	2.7	8.3	29.0
RG-393	M17/127-RG393	50	69.5	29.4	#12 Solid	TFE	D	TFE	0.390	5000	0.2	0.5	1.7	6.1
RG-400	M17/128-RG400	50	69.5	29.4	#20 Solid	TFE	D	TFE	0.195	1900	0.4	1.1	3.9	13.2
LMR500	TMS LMR500	50	85	23.9	#7 Solid	FPE	FC	PE	0.500	2500	0.1	0.3	0.9	3.3
LMR600	TMS LMR600	50	86	23.4	#5.5 Solid	FPE	FC	PE	0.590	4000	0.1	0.2	0.8	2.7
LMR1200	TMS LMR1200	50	88	23.1	#0 Tube	FPE	FC	PE	1.200	4500	0.04	0.1	0.4	1.3
<b>Hardline</b>														
1/2"	CATV Hardline	50	81	25.0	#5.5	FPE	SM	none	0.500	2500	0.05	0.2	0.8	3.2
1/2"	CATV Hardline	75	81	16.7	#11.5	FPE	SM	none	0.500	2500	0.1	0.2	0.8	3.2
7/8"	CATV Hardline	50	81	25.0	#1	FPE	SM	none	0.875	4000	0.03	0.1	0.6	2.9
7/8"	CATV Hardline	75	81	16.7	#5.5	FPE	SM	none	0.875	4000	0.03	0.1	0.6	2.9
LDF4-50A	Heliac - 1/2"	50	88	25.9	#5 Solid	FPE	CC	PE	0.630	1400	0.05	0.2	0.6	2.4
LDF5-50A	Heliac - 7/8"	50	88	25.9	0.355"	FPE	CC	PE	1.090	2100	0.03	0.10	0.4	1.3
LDF6-50A	Heliac - 1 1/4"	50	88	25.9	0.516"	FPE	CC	PE	1.550	3200	0.02	0.08	0.3	1.1
<b>Parallel Lines</b>														
TV Twinlead		300	80	5.8	#20	PE	none	P1	0.500					
Transmitting Tubular		300	80	5.8	#20	PE	none	P1	0.500	8000	0.09	0.3	1.1	3.9
Window Line		450	91	4.0	#18	PE	none	P1	1.000	10000	0.02	0.08	0.3	1.1
Open Wire Line		600	92	1.1	#12	none	none	none	varies	12000	0.02	0.06	0.2	0.7
<b>Approximate Power Handling Capability (1:1 SWR, 40°C Ambient):</b>														
	1.8 MHz	7	14	30	50	150	220	450	1 GHz					
RG-58 Style	1350	700	500	350	250	150	120	100	50					
RG-59 Style	2300	1100	800	550	400	250	200	130	90					
RG-8X Style	1830	840	560	360	270	145	115	80	50					
RG-8/213 Style	5900	3000	2000	1500	1000	600	500	350	250					
RG-217 Style	20000	9200	6100	3900	2900	1500	1200	800	500					
LDF4-50A	38000	18000	13000	8200	6200	3400	2800	1900	1200					
LDF5-50A	67000	32000	22000	14000	11000	5900	4800	3200	2100					
LMR500	12000	6000	4200	2800	2200	1200	1000	700	450					
LMR1200	39000	19000	13000	8800	6700	3800	3100	2100	1400					

<b>Legend:</b>			
ASPE	Air Spaced Polyethylene	P1	PVC, Class 1
P2	PVC, Class 2	PE	Polyethylene
BF	Flooded direct bury	S	Single Shield
CC	Corrugated Copper	SM	Smooth Aluminum
D	Double Copper Shields	TFE	Teflon
DRF	Davis RF	TMS	Times Microwave
FC	Foil/Copper Shields	WM	Wireman
FPE	Foamed Polyethylene	**	Not Available or varies
Heliac	Andrew Corp Heliac		
N	Non-Contaminating		

## Voltage and Power Ratings

Selection of the correct coaxial cable for a particular application is not a casual matter. Not only is the attenuation loss of significance, but breakdown and heating (voltage and power) also need to be considered. If a cable were lossless, the power handling capability would be limited only by the breakdown voltage. RG-58, for example, can withstand an operating potential of 1400 V RMS. In a 52-Ω system this equates to more than 37 kW, but the current corresponding to this power level is 27 amperes, which would obviously melt the conductors in RG-58. In practical coaxial cables, the copper and dielectric losses, rather than breakdown voltage, limit the maximum power than can be accommodated. If 1000 W is applied to a cable having a loss of 3 dB, only 500 W is delivered to the load. The remaining 500 W must be dissipated in the cable. The dielectric and outer jacket are good thermal insulators, which prevent the conductors from efficiently transferring the heat to free air.

As the operating frequency increases, the power-handling capability of a cable decreases because of increasing conductor loss (skin effect) and dielectric loss. RG-58 with foam dielectric has a breakdown rating of only 300 V, yet it can handle substantially more power than its ordinary solid dielectric counterpart because of the lower losses. Normally, the loss is inconsequential (except as it affects power handling capability) below 10 MHz in amateur applications. This is true unless extremely long runs of cable are used. In general, full legal amateur power can be safely applied to inexpensive RG-58 coax in the bands below 10 MHz. Cables of the RG-8 family can withstand full amateur power through the VHF spectrum, but connectors must be carefully chosen in these applications. Connector choice is discussed in a later section.

Excessive RF operating voltage in a coaxial cable can cause noise generation, dielectric damage and eventual breakdown between the conductors.

## Shielded Parallel Lines

Shielded balanced lines have several advantages over open-wire lines. Since there is no noise pickup on long runs, they can be buried and they can be routed through metal buildings or inside metal piping. Shielded balanced lines having impedances of 140 or 100 Ω can be constructed from two equal lengths of 70-Ω or 50-Ω cable (RG-59 or RG-58 would be satisfactory for amateur power levels). Paralleled RG-63 (125-Ω) cable would make a balanced transmission line more in accord with traditional 300-Ω twin-lead feed line ( $Z_0 = 250 \Omega$ ).

The shields are connected together (see [Fig 24A](#)), and the two inner conductors constitute the balanced line. At the input, the coaxial shields should be connected to chassis ground; at the output (the antenna side), they are joined but left floating.

A high power, low-loss, low-impedance 70-Ω (or 50-Ω) balanced line can be constructed from four coaxial cables. See [Fig 24B](#). Again, the shields are all connected together. The center conductors of the two sets of coaxial

cables that are connected in parallel provide the balanced feed.

## Coaxial Fittings

There is a wide variety of fittings and connectors designed to go with various sizes and types of solid-dielectric coaxial line. The *UHF* series of fittings is by far the most widely used type in the amateur field, largely because they are widely available and are inexpensive. These fittings, typified by the PL-259 plug and SO-239 chassis fitting

**Table 2**  
**Coaxial Cable Equations**

$$C \text{ (pF/foot)} = \frac{7.26\epsilon}{\log(D/d)} \quad (\text{Eq A})$$

$$L \text{ (}\mu\text{H/foot)} = 0.14 \log \frac{D}{d} \quad (\text{Eq B})$$

$$Z_0 \text{ (ohms)} = \sqrt{\frac{L}{C}} = \left( \frac{138}{\sqrt{\epsilon}} \right) \left( \log \frac{D}{d} \right) \quad (\text{Eq C})$$

$$\text{VF \% (velocity factor, ref. speed of light)} = \frac{100}{\sqrt{\epsilon}} \quad (\text{Eq D})$$

$$\text{Time delay (ns/foot)} = 1.016 \sqrt{\epsilon} \quad (\text{Eq E})$$

$$f \text{ (cutoff/GHz)} = \frac{750}{\sqrt{\epsilon}(D+d)} \quad (\text{Eq F})$$

$$\text{Reflection Coefficient} = |\rho| = \frac{Z_L - Z_0}{Z_L + Z_0} = \frac{\text{SWR} - 1}{\text{SWR} + 1} \quad (\text{Eq G})$$

$$\text{SWR} = \frac{1 + |\rho|}{1 - |\rho|} \quad (\text{Eq H})$$

$$V_{\text{peak}} = \frac{(1.15 S_d)(\log D/d)}{K} \quad (\text{Eq I})$$

$$A = \frac{0.435}{Z_0 D} \left( \frac{D}{d} (K1 + K2) \right) \sqrt{f} + 2.78 \sqrt{\epsilon} (\text{PF})(f) \quad (\text{Eq J})$$

where

A = attenuation in dB/100 foot

d = OD of inner conductor

D = ID of outer conductor

S = max voltage gradient of insulation in volts/mil

$\epsilon$  = dielectric constant

K = safety factor

K1 = strand factor

K2 = braid factor

f = freq in MHz

PF = power factor

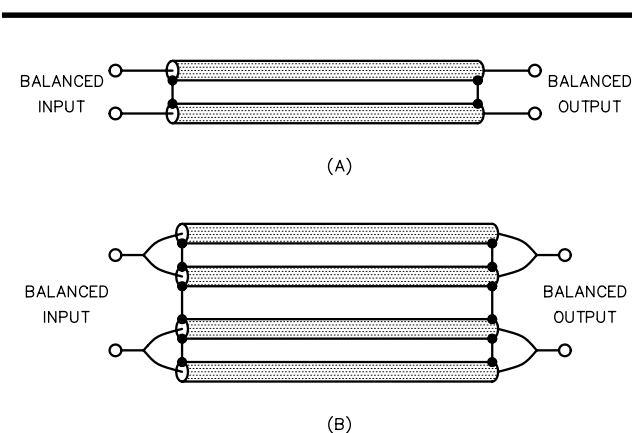
Note: Obtain K1 and K2 data from manufacturer.

(military designations) are quite adequate for VHF and lower frequency applications, but are not weatherproof. Neither do they exhibit a 52-Ω impedance.

Type N series fittings are designed to maintain constant impedance at cable joints. They are a bit harder to assemble than the UHF type, but are better for frequencies above 300 MHz or so. These fittings are weatherproof.

The BNC fittings are for small cable such as RG-58, RG-59 and RG-62. They feature a bayonet-locking arrangement for quick connect and disconnect, and are weatherproof. They exhibit a constant impedance.

Methods of assembling connectors on the cable are



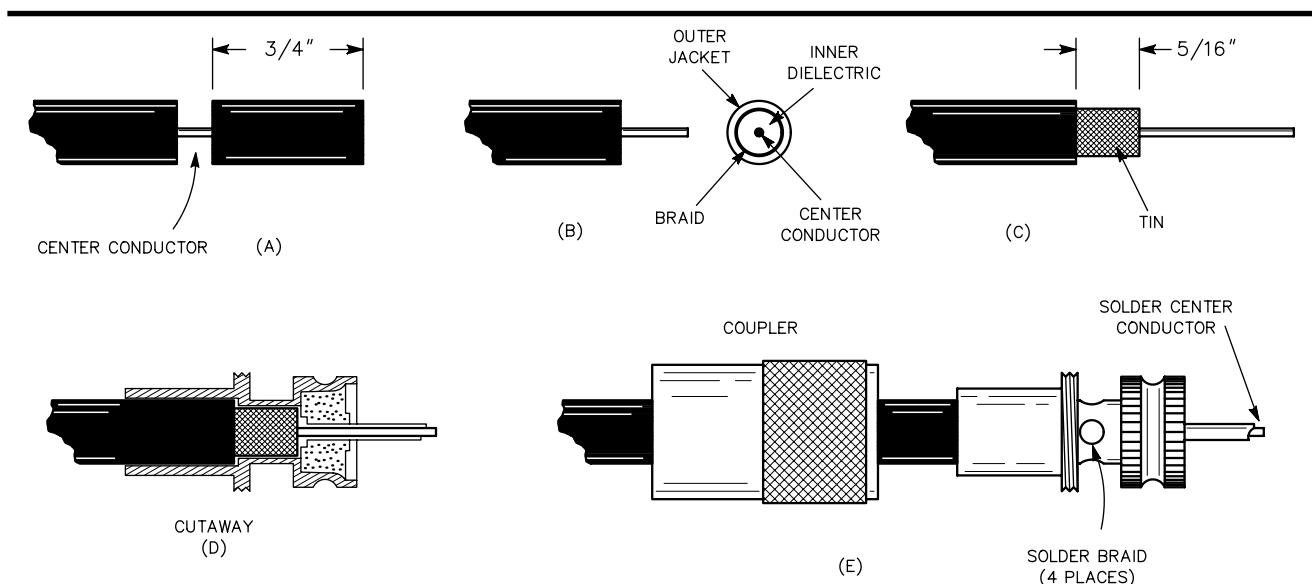
**Fig 24—Shielded balanced transmission lines utilizing standard small-size coaxial cable, such as RG-58 or RG-59. These balanced lines may be routed inside metal conduit or near large metal objects without adverse effects.**

shown in Figs 25, 26, 27, 28 and 29. The most common or longest established connector in each series is illustrated. Several variations of each type exist. Assembly instructions for coaxial fittings not shown here are available from the manufacturers.

### PL-259 Assembly

**Fig 25** shows how to install the solder type of PL-259 connector on RG-8 type cable. Proper preparation of the cable end is the key to success. Follow these simple steps.

- 1) Measure back  $\frac{3}{4}$  inch from the cable end and slightly score the outer jacket around its circumference.
- 2) With a sharp knife, cut along the score line through the outer jacket, through the braid, and through the dielectric material, right down to the center conductor. Be careful not to score the center conductor. Cutting through all outer layers at once keeps the braid from separating.
- 3) Pull the severed outer jacket, braid and dielectric off the end of the cable as one piece. Inspect the area around the cut, looking for any strands of braid hanging loose. If there are any, snip them off. There won't be any if your knife was sharp enough.
- 4) Next, score the outer jacket  $\frac{5}{16}$  inch back from the first cut. Cut through the jacket lightly; do not score the braid. This step takes practice. If you score the braid, start again.
- 5) Remove the outer jacket. Tin the exposed braid and center conductor, but apply the solder sparingly. Avoid melting the dielectric.
- 6) Slide the coupling ring onto the cable. (*Don't forget this important step!*)
- 7) Screw the connector body onto the cable. If you prepared



**Fig 25—The PL-259 or UHF connector is almost universal for amateur HF work and is popular for equipment operating up through the VHF range. Steps for assembly are given in detail in the text.**



the cable to the right dimensions, the center conductor will protrude through the center pin, the braid will show through the solder holes, and the body will actually thread itself onto the outer cable jacket.

- 8) With a large soldering iron, solder the braid through each of the four solder holes. Use enough heat to flow the solder onto the connector body, but not so much as to melt the dielectric. Poor connection to the braid is a the most common form of PL-259 failure. This connection is just as important as that between the center conductor and the connector. With some practice you'll learn how much heat to use.
- 9) Allow the connector body to cool somewhat, and then solder the center connector to the center pin. The solder should flow on the inside, not the outside of the pin. Trim the center conductor to be even with the end of the center pin. Use a small file to round the end, removing any solder that may have built up on the outer surface of the center pin. Use a sharp knife, very fine sandpaper, or steel wool to remove any solder flux from the outer surface of the center pin.
- 10) Screw the coupling onto the body, and the job is finished.

**Fig 26** shows two options for using RG-58 or RG-59 cable with PL-259 connectors. The crimp-on connectors manufactured for the smaller cable work well if installed correctly. The alternative method involves using adapters for the smaller cable with standard PL-259 connectors made for RG-8. Prepare the cable as shown in Fig 26. Once the braid is prepared, screw the adapter into the PL-259 shell and finish the job as you would with RG-8 cable.

**Fig 27** shows how to assemble female SO-239 connectors onto coaxial cable. **Figs 28** and **29** respectively show the assembly of BNC and type N connectors.

### SINGLE-WIRE LINE

There is one type of line, in addition to those already described, that deserves mention because it is still used to a limited extent. This is the *single-wire line*, consisting simply of a single conductor running from the transmitter to the antenna. The return circuit for such a line is the earth; in fact, the second conductor of the line can be considered to be the image of the actual conductor in the same way that an antenna strung above the earth has an image (see [Chapter 3](#)). The characteristic impedance of the single wire line depends on the conductor size and the height of the wire above ground, ranging from 500 to 600 ohms for #12 or #14 conductors at heights of 10 to 30 feet. The characteristic impedance may be calculated from

$$Z_0 = 138 \log \frac{4h}{d} \quad (\text{Eq 27})$$

where

$Z_0$  = characteristic impedance of the single wire line

$h$  = antenna height

$d$  = wire diameter, in same units as  $h$

By connecting the line to the antenna at a point that

represents a resistive impedance of 500 to 600  $\Omega$ , the line can be matched and operated without standing waves.

Although the single wire line is very simple to install, it has at least two outstanding disadvantages. First, because the return circuit is through the earth, the behavior of the system depends on the kind of ground over which the antenna and transmission lines are erected. In part may not be possible to get the necessary good connection to actual ground that is required at the transmitter. Second, the line always radiates, because there is no nearby second conductor to cancel the fields. Radiation is minimum when the line is properly terminated, because the line current is lowest under these conditions. The line is, however, always a part of the radiating antenna system, to some extent.

## LINE INSTALLATION

### Installing Coax Line

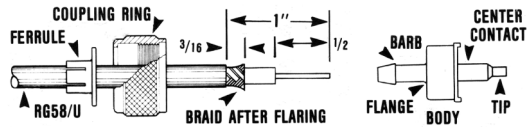
One great advantage of coaxial line, particularly the flexible dielectric type, is that it can be installed with almost no regard for its surroundings. It requires no insulation, can be run on or in the ground or in piping, can be bent around corners with a reasonable radius, and can be snaked through places such as the space between walls where it would be impractical to use other types of lines. However, coaxial lines should always be operated in systems that permit a low SWR, and precautions must be taken to prevent RF currents from flowing on the *outside* of the line. This is discussed in [Chapter 26](#). Additional information on line installation is given in [Chapter 4](#).

### Installing Parallel-Wire Lines

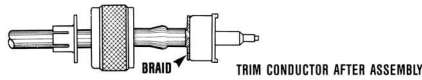
In installing a parallel wire line, care must be used to prevent it from being affected by moisture, snow and ice. In home construction, only spacers that are impervious to moisture and are unaffected by sunlight and weather should be used on air insulated lines. Steatite spacers meet this requirement adequately, although they are somewhat heavy. The wider the line spacing, the longer the leakage path across the spacers, but this cannot be carried too far without running into line radiation, particularly at the higher frequencies. Where an open wire line must be anchored to a building or other structure, standoff insulators of a height comparable with the line spacing should be used if mounted in a spot that is open to the weather. Lead-in bushings for bringing the line into a building also should have a long leakage path.

The line should be kept away from other conductors, including downspouts, metal window frames, flashing, etc, by a distance of two or three times the line spacing. Conductors that are very close to the line will be coupled to it to some degree, and the effect is that of placing an additional load across the line at the point where the coupling occurs. Reflections take place from this coupled load, raising the SWR. The effect is at its worst when one wire is closer than the other to the external conductor. In such a case one wire carries a heavier load than the other, with the result

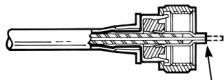
83-58FCP



1. Strip cable - **don't nick braid, dielectric or conductor.** Slide ferrule, then coupling ring on cable. Flare braid slightly by rotating conductor and dielectric in circular motion.



2. Slide body on dielectric, barb going under braid until flange is against outer jacket. Braid will fan out against body flange



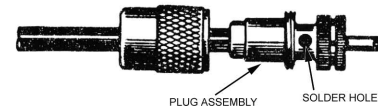
3. Slide nut over body. Grasp cable with hand and push ferrule over barb until braid is captured between ferrule and body flange. Squeeze crimp tip only of center contact with pliers; alternate-solder tip.



2. Fan braid slightly and fold back over cable.

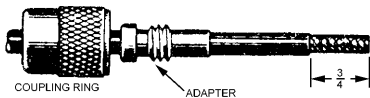


3. Position adapter to dimension shown. Press braid down over body of adapter and trim to 3/8". Bare 5/8" of conductor. Tin exposed center conductor.



4. Screw the plug assembly on adapter. Solder braid to shell through solder holes. Solder conductor to contact sleeve.

83-1SP (PL-259) PLUG WITH ADAPTERS (UG-176/U OR UG-175/U)

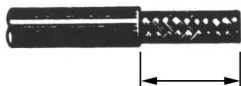


1. Cut end of cable even. Remove vinyl jacket 3/4" - don't nick braid. Slide coupling ring and adapter on cable.



5. Screw coupling ring on plug assembly.

**Fig 26—Crimp-on connectors and adapters for use with standard PL-259 connectors are popular for connecting to RG-58 and RG-59 coax. (This material courtesy of Amphenol Electronic Components, RF Division, Bunker Ramo Corp.)**



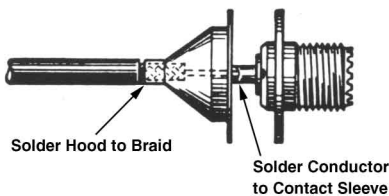
1) Cut end of cable even: Remove vinyl jacket to dimension appropriate for type of hood. Tin exposed



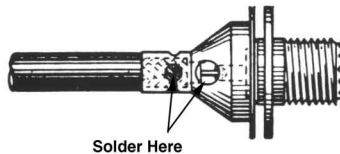
2) Remove braid and dielectric to expose center conductor. Do not nick conductor.



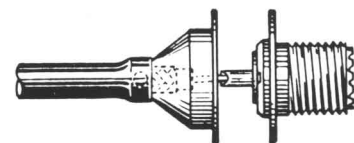
3) Remove braid to expose dielectric to appropriate dimension. Tin center conductor. Soldering assembly depends on hood used, as illustrated.



4) Slide hood over braid. Solder conductor to contact. Slide hood flush against receptacle and bolt both to chassis. Solder hood to braid as illustrated. Tape this junction if necessary. (for UG-177/U)



5) Slide hood over braid. Bring receptacle flush against hood. Solder hood to braid and conductor to contact sleeve through solder holes as illustrated. Tape junction if necessary. (for UG-372/U)

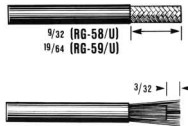


6) Slide hood over braid and force under vinyl. Place inner conductor in contact sleeve and solder. Push hood flush against receptacle. Solder hood to braid through solder holes. Tape junction if necessary. (for UG-106/U)

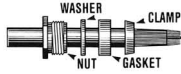
**Fig 27—Assembly of the 83 series (SO-239) with hoods. Complete electrical shield integrity in the UHF female connector requires that the shield be attached to the connector flange by means of a hood.**

## BNC CONNECTORS

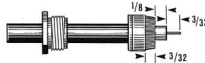
### Standard Clamp



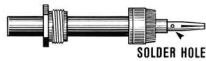
1. Cut cable even. Strip jacket. Fray braid and strip dielectric. **Don't nick braid or center conductor.** Tin center conductor.



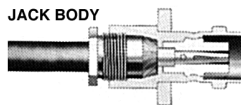
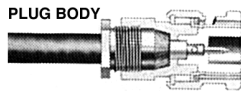
2. Taper braid. Slide nut, washer, gasket and clamp over braid. Clamp inner shoulder should fit squarely against end of jacket.



3. With clamp in place, comb out braid, fold back smooth as shown. Trim center conductor.

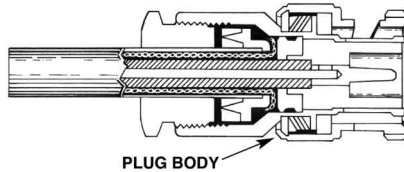
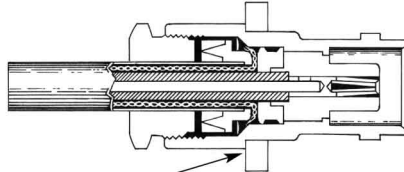
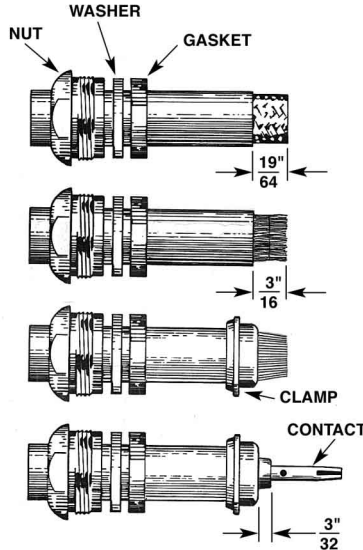


4. Solder contact on conductor through solder hole. Contact should butt against dielectric. Remove excess solder from outside of contact. Avoid excess heat to prevent swollen dielectric which would interfere with connector body.



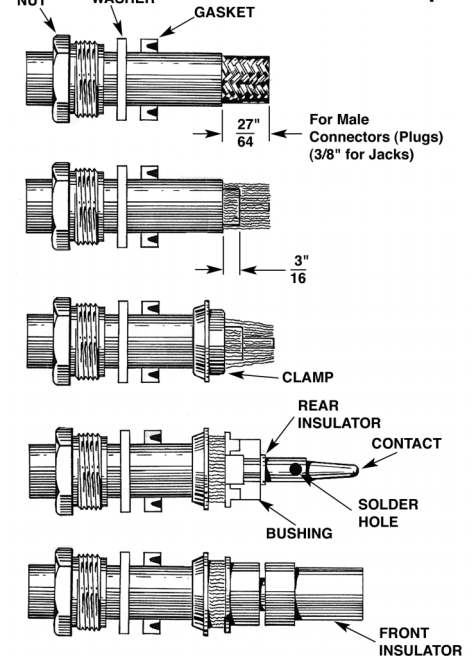
5. Push assembly into body. Screw nut into body with wrench until tight. **Don't rotate body on cable to tighten.**

### Improved Clamp



Follow 1, 2, 3 and 4 in BNC connectors (standard clamp) except as noted. Strip cable as shown. Slide gasket on cable with groove facing clamp. Slide clamp with sharp edge facing gasket. Clamp should cut gasket to seal properly.

### C. C. Clamp



1. Follow steps 1, 2, and 3 as outlined for the standard-clamp BNC connector.

2. Slide on bushing, rear insulator and contact. The parts must butt securely against each other, as shown.

3. Solder the center conductor to the contact. Remove flux and excess solder.

4. Slide the front insulator over the contact, making sure it butts against the contact shoulder.

5. Insert the prepared cable end into the connector body and tighten the nut. Make sure the sharp edge of the clamp seats properly in the gasket.

**Fig 28—BNC connectors are common on VHF and UHF equipment at low power levels. (Courtesy of Amphenol Electronic Components, RF Division, Bunker Ramo Corp.)**

that the line currents are no longer equal. The line then becomes unbalanced.

Solid dielectric, two-wire lines have a relatively small external field because of the small spacing, and can be mounted within a few inches of other conductors without much danger of coupling between the line and such conductors. Standoff insulators are available for supporting lines of this type when run along walls or similar structures.

Sharp bends should be avoided in any type of transmission line, because such bends cause a change in the

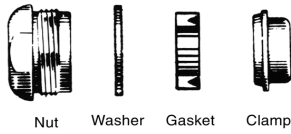
characteristic impedance. The result is that reflections take place from each bend. This is of less importance when the SWR is high than when an attempt is being made to match the load to the line  $Z_0$ . It may be impossible to get the SWR to the desired figure until bends in the line are made very gradual.

### TESTING TRANSMISSION LINES

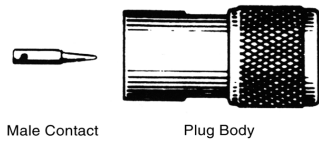
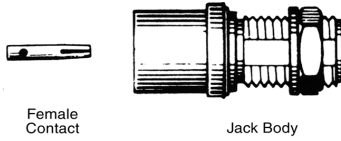
Coaxial cable loss should be checked at least every two years if the cable is installed outdoors or buried. (See earlier

# TYPE N CONNECTORS

## Standard Clamp

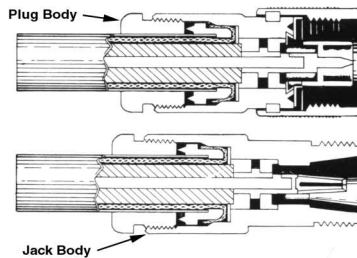
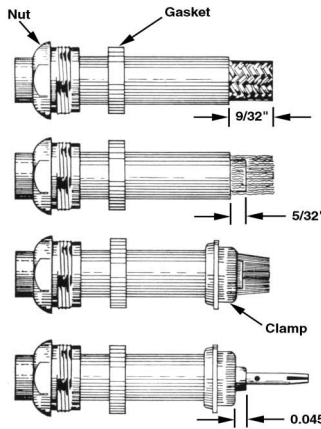


4. Smooth braid over clamp and trim. Soft-solder contact to center conductor. Avoid use of excessive heat and solder. See that end of dielectric is clean. Contact must be flush against dielectric. Outside of contact must be free of solder. Female contact is shown; procedure is similar to male contact.

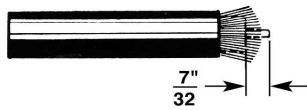


5. Slide body into place carefully so that contact enters hole in insulator (male contact shown). Face of dielectric must flush against insulator. Slide completed assembly into body by pushing nut. When nut is in place tighten with wrenches. In connectors with gland, knife edge should cut gasket in half by tightening sufficiently.

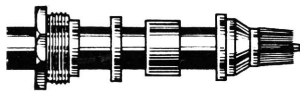
## Improved Clamp



1. Cut cable even. Remove 9/16" of vinyl jacket. When using double-shielded cable remove 5/8".



2. Comb out copper braid as shown. Cut off dielectric 7/32" from end. Tin center conductor.

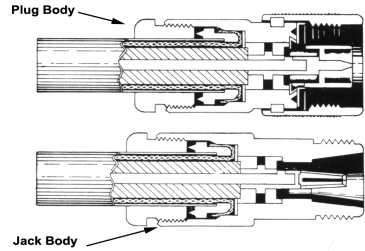
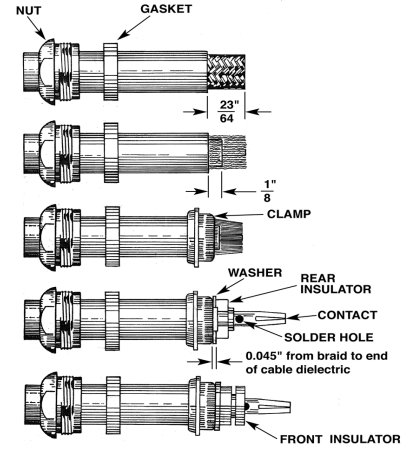


3. Taper braid as shown. Slide nut, washer and gasket over vinyl jacket. Slide clamp over braid with internal shoulder of clamp flush against end of vinyl jacket. When assembling connectors with gland, be sure knife-edge is toward end of cable and groove in gasket is toward gland.

1) Follow instructions 1 through 4 as detailed in the standard clamp (be sure to use the correct dimensions).

2) Slide the body over the prepared cable end. Make sure the sharp edges of the clamp seat properly in the gasket. Tighten the nut.

## C. C. Clamp



1) Follow instructions 1 through 3 as outlined for the standard-clamp Type N connector.

2) Slide on the washer, rear insulator and contact. The parts must butt securely against each other.

3) Solder the center conductor to the contact. Remove flux and excess solder.

4) Slide the front insulator over the contact, making sure it butts against the contact shoulder.

5) Insert the prepared cable end into the connector body and tighten the nut. Make sure the sharp edge of the clamp seats properly in the gasket.

**Fig 29—Type N connectors are required for high-power operation at VHF and UHF. (Courtesy of Amphenol Electronic Components, RF Division, Bunker Ramo Corp.)**

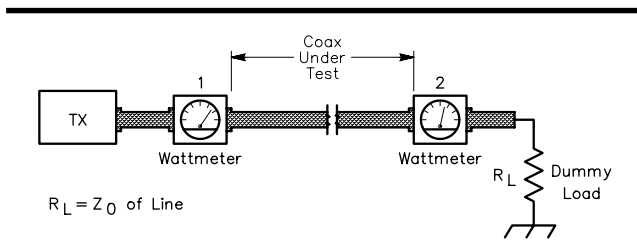
section on losses and deterioration.) Testing of any type of line can be done using the technique illustrated in Fig 30. If the measured loss in watts equates to more than 1 dB over the rated matched-line loss per 100 feet, the line should be replaced. The matched-line loss in dB can be determined from

$$dB = 10 \log \frac{P_1}{P_2} \quad (\text{Eq } 28)$$

where

$P_1$  is the power at the transmitter output  
 $P_2$  is the power measured at  $R_L$  of Fig 30.

Yet other methods of determining line losses may be used. If the line input impedances can be measured accurately with a short- and then an open-circuit termination, the electrical line length (determined by velocity factor) and the matched-line loss may be calculated for the frequency of



**Fig 30—Method for determining losses in transmission lines. The impedance of the dummy load must equal the  $Z_0$  of the line for accurate results.**

measurement. The procedure is described in [Chapter 28](#).

Determining line characteristics as just mentioned requires the use of a laboratory style of impedance bridge, or at least an impedance or noise bridge calibrated to a high degree of accuracy. But useful information about a transmission line can also be learned with just an SWR indicator, if it offers reliable readings at high SWR values.

A lossless line theoretically exhibits an infinite SWR when terminated in an open or a short circuit. A practical line will have losses, and therefore will limit the SWR at the line input to some finite value. Provided the signal source can operate safely into a severe mismatch, an SWR indicator can be used to determine the line loss. The instruments available to most amateurs lose accuracy at SWR values greater than about 5:1, so this method is useful principally as a go/no-go check on lines that are fairly long. For short, low-loss cables, only significant deterioration can be detected by the open-circuit SWR test.

First, either open or short circuit one end of the line. It makes no difference which termination is used, as the terminating SWR is theoretically infinite in either case. Then measure the SWR at the other end of the line. The matched-

line loss for the frequency of measurement may then be determined from

$$L_m = 10 \log \frac{\text{SWR} + 1}{\text{SWR} - 1} \quad (\text{Eq 29})$$

where SWR = the SWR value measured at the line input

## BIBLIOGRAPHY

Source material and more extended discussion of topics covered in this chapter can be found in the references given below and in the textbooks listed at the end of [Chapter 2](#).

- C. Brainard and K. Smith, "Coaxial Cable—The Neglected Link," *QST*, Apr 1981, pp 28-31.
- D. DeMaw, "In-Line RF Power Metering," *QST*, Dec 1969.
- D. Geiser, "Resistive Impedance Matching with Quarter-Wave Lines," *QST*, Feb 1963, pp 56-57.
- H. Jasik, *Antenna Engineering Handbook*, 1st ed. (New York: McGraw-Hill, 1961).
- R. C. Johnson and H. Jasik, *Antenna Engineering Handbook*, 2nd ed. (New York: McGraw-Hill, 1984), pp 43-27 to 43-31.
- R. W. P. King, H. R. Mimno and A. H. Wing, *Transmission Lines, Antennas and Waveguides* (New York: Dover Publications, Inc., 1965).
- J. D. Kraus, *Antennas* (New York: McGraw-Hill Book Co., 1950).
- Kurokawa, "Power Waves and the Scattering Matrix," *IEEE Transactions on Microwave Theory and Techniques*, Vol MTT-13, Mar 1965, pp 194-202.
- M. W. Maxwell, "Another Look at Reflections," *QST*, Apr, Jun, Aug and Oct 1973, Apr and Dec 1974, and Aug 1976.
- M. W. Maxwell, *Reflections* (ARRL: Newington, CT, 1990).
- T. McMullen, "The Line Sampler, an RF Power Monitor for VHF and UHF," *QST*, April 1972.
- H. Weinstein, "RF Transmission Cable for Microwave Applications," *Ham Radio*, May 1985, p 106.

# Coupling the Transmitter to the Line

How many times have you heard someone on the air saying how he just spent hours and hours pruning his antenna to achieve a 1:1 SWR? Indeed, have you ever wondered whether all that effort was worthwhile? Now don't get the wrong impression: a 1:1 SWR is *not* a bad thing! Feed-line loss is minimized when the SWR is kept within reasonable bounds. The power for which a particular transmission line is rated is for a matched load.

Modern amateur transceivers use broadband, untuned solid-state final amplifiers, designed to operate into 50  $\Omega$ . Such a transmitter is able to deliver its rated output power—at the rated level of distortion—only when it is operated into the load for which it was designed. An SSB transmitter that is *splattering* is often being driven hard into the wrong load impedance.

Further, modern radios often employ protection circuitry to reduce output power automatically if the SWR rises to more than about 2:1. Protective circuits are needed because solid-state devices can almost instantly destroy themselves trying to deliver power into the wrong load impedance. Modern solid-state transceivers often include built-in antenna tuners (often at extra cost) to match impedances when the SWR isn't 1:1.

Older vacuum-tube amplifiers were a lot more forgiving than solid-state devices—they could survive momentary overloads without being instantly destroyed. The pi-networks used to tune and load old-fashioned vacuum-tube amplifiers were able to match a fairly wide range of impedances.

## MATCHING THE LINE TO THE TRANSMITTER

As shown in [Chapter 24](#), the impedance at the input of a transmission line is uniquely determined by a number of factors: the frequency, the characteristic impedance  $Z_0$  of the line, the physical length, velocity factor and the matched-line loss of the line, plus the impedance of the load (the antenna) at the output end of the line. If the impedance at the input of the transmission line connected to the transmitter differs appreciably from the load resistance into which the transmitter output circuit is designed to operate, an impedance-matching network must be inserted between the transmitter and the line input terminals.

In older ARRL publications, such an impedance-

matching network was often called a *Transmatch*. This is a coined word, referring to a “Transmitter Matching” network. Nowadays, radio amateurs commonly call such a device an *antenna tuner*.

The function of an antenna tuner is to transform the impedance at the input end of the transmission line—whatever it may be—to the 50  $\Omega$  needed to keep the transmitter loaded properly. An antenna tuner does *not* alter the SWR on the transmission line going to the antenna. It only ensures that the transmitter sees the 50- $\Omega$  load for which it was designed.

Column one of **Tables 1** and **2** list the computed impedance at the center of two dipoles mounted over average ground (with a conductivity of 5 mS/m and a dielectric constant of 13). The dipole in **Table 1** is 100 feet long, and is mounted as a flattop, 50 feet high. The dipole in **Table 2** is 66 feet long overall, mounted as an inverted-V, whose apex is 50 feet high and whose legs have an included angle of 120°. The second column in **Tables 1** and **2** show the computed impedance at the transmitter end of a 100-foot long transmission line using 450- $\Omega$  window open-wire line. Please recognize that there is nothing special or “magic” about these antennas—they are merely representative of typical antennas used by real-world amateurs.

The impedance at the input of the transmission line

**Table 1**  
**Impedance of Center-Fed 100' Flattop Dipole, 50' High Over Average Ground**

Frequency MHz	Antenna Feed-Point Impedance, $\Omega$	Impedance at Input of 100' 450- $\Omega$ Line, $\Omega$
1.83	$4.5 - j 1673$	$2.0 - j 20$
3.8	$39 - j 362$	$888 - j 2265$
7.1	$481 + j 964$	$64 - j 24$
10.1	$2584 - j 3292$	$62 - j 447$
14.1	$85 - j 123$	$84 - j 65$
18.1	$2097 + j 1552$	$2666 - j 884$
21.1	$345 - j 1073$	$156 + j 614$
24.9	$202 + j 367$	$149 - j 231$
28.4	$2493 - j 1375$	$68 - j 174$

**Table 2**  
**Impedance of Center-Fed 66' Inv-V Dipole, 50' at Apex, 120° Included Angle Over Average Ground**

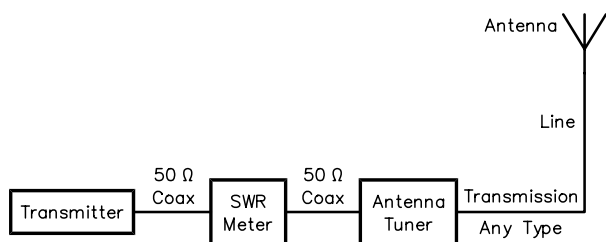
Frequency MHz	Antenna Feed-Point Impedance, $\Omega$	Impedance at Input of 100' 450- $\Omega$ Line, $\Omega$
1.83	$1.6 - j 2257$	$1.6 - j 44$
3.8	$10 - j 879$	$2275 + j 8980$
7.1	$65 - j 41$	$1223 - j 1183$
10.1	$22 + j 648$	$157 - j 1579$
14.1	$5287 - j 1310$	$148 - j 734$
18.1	$198 - j 820$	$138 - j 595$
21.1	$103 - j 181$	$896 - j 857$
24.9	$269 + j 570$	$99 - j 140$
28.4	$3089 + j 774$	$74 - j 223$

varies over an extremely wide range when antennas like these are used over the entire range of amateur bands from 160 to 10 meters. The impedance at the input of the line (that is, at the antenna tuner's output terminals) *will be different* if the length of the line is changed. It should be obvious that an antenna tuner used with such a system must be very flexible to match the wide range of impedances it will encounter—and it must do so without arcing or blowing up.

### The Matching System

Over the years, radio amateurs have derived a number of circuits for use as antenna tuners. At one time, when open-wire transmission line was more widely used, link-coupled tuned circuits were in vogue. With the increasing popularity of coaxial cable used as feed lines, other circuits have become more prevalent. The most common form of antenna tuner in recent years is some variation of a *T-network* configuration.

The basic system of a transmitter, matching circuit, transmission line and antenna is shown in **Fig 1**. As usual, we assume that the transmitter is designed to deliver its rated power into a load of 50  $\Omega$ . The problem is one of designing a matching circuit that will transform the actual line impedance at the input of the transmission line into a resistance of 50  $\Omega$ . This resistance will be unbalanced; that is, one side will be grounded, since modern transmitters universally ground one side of the output connector to the



**Fig 1—Essentials of a coupling system between transmitter and transmission line.**

chassis. The line to the antenna, however, may be unbalanced (coaxial cable) or balanced (parallel-conductor line), depending on whether the antenna itself is unbalanced or balanced.

### Harmonic Attenuation in an Antenna Tuner

This is a good place to bring up the topic of harmonic attenuation, as it is related to antenna tuners. One potentially desirable characteristic of an antenna tuner is the degree of extra harmonic attenuation it can provide. While this is desirable in theory, it is not always achieved in practice. For example, if an antenna tuner is used with a single, fixed-length antenna on multiple bands, the impedances presented to the tuner at the fundamental frequency and at the harmonics will often be radically different. The amount of harmonic attenuation for a particular network will thus be dramatically variable also. See Table 2. For example, at 7.1 MHz, the impedance seen by the antenna tuner for the 66-foot inverted-V dipole is  $1223 - j 1183 \Omega$ . At 14.1 MHz, roughly the second harmonic, the impedance is  $148 - j 734 \Omega$ .

### Trapped Antennas

There are some situations in amateur radio where the impedance at the second harmonic is essentially the same as that for the fundamental. This often involves *trapped* antenna systems or wideband log-periodic designs. For example, a system used by many amateurs is a *triband* Yagi that works on 20, 15 and 10 meters. The second harmonic of a 20-meter transmitter feeding such a tribander can be objectionably strong for nearby amateurs operating on 10 meters. This is despite the approximately 60 dB of attenuation of the second harmonic provided by the low-pass filters built into modern solid-state transceivers. A linear amplifier can exacerbate the problem, since its second harmonic may be suppressed only about 46 dB by the typical pi-network output circuit used in most amplifiers.

Even in a trapped antenna system, most amateur antenna tuners will not attenuate the 10-meter harmonic much at all, especially if the tuner uses a high-pass T-network. This is the most common network used commercially because of the wide range of impedances it will match. Some T-network designs have attempted to improve the harmonic attenuation using parallel inductors and capacitors instead of a single inductor for the center part of the tee. Unfortunately, this often leads to more loss and more critical tuning at the fundamental, while providing little, if any, additional harmonic suppression in actual installations.

### Harmonics and Pi-Network Tuners

In a trapped antenna system, if a different network is used for an antenna tuner (such as a low-pass Pi network), there will be additional attenuation of harmonics, perhaps as much as 30 dB for a loaded Q of 3. The exact degree of harmonic attenuation, however, is often limited due to the stray inductance and capacity present in most tuners at harmonic frequencies. Further, the matching range for a Pi-

network tuner is fairly limited because of the range of input and output capacitance needed for widely varying loads.

### Harmonics and Stubs

Far more reliable suppression of harmonics can be achieved using shorted quarter-wave transmission-line stubs at the transmitter output. A typical 20-meter  $\lambda/4$  shorted stub (which is an open circuit at 20 meters, but a short circuit at 10 meters) will provide about 25 dB of attenuation to the second harmonic. It will handle full legal amateur power too. See [Chapter 26](#) for more details on stubs. In short, an antenna tuner that is capable of matching a wide range of impedances should not be relied on to give additional harmonic suppression.

### MATCHING WITH INDUCTIVE COUPLING

Inductively coupled matching circuits are shown in basic form in **Fig 2**. R1 is the actual load resistance to which the power is to be delivered, and R2 is the resistance seen by the power source. The objective is to make it  $R2 = 50 \Omega$ . L1 and C1 form a resonant circuit capable of being tuned to the operating frequency. The coupling between L1 and L2 is adjustable.

The circuit formed by C1, L1 and L2 is equivalent to a transformer having a primary-to-secondary impedance ratio adjustable over wide limits. The resistance coupled into L2 from L1 depends on the effective Q of the circuit L1-C1-R1, the reactance of L2 at the operating frequency, and the coefficient of coupling, k, between the two coils. The approximate relationship is (assuming C1 is properly tuned)

$$R2 = k^2 X_{L2} Q \quad (\text{Eq 1})$$

where  $X_{L2}$  is the reactance of L2 at the operating frequency. The value of L2 is optimum when  $X_{L2} = R2$ , in which case

the desired value of R2 is obtained when

$$k = \frac{1}{\sqrt{Q}} \quad (\text{Eq 2})$$

This means that the desired value of R2 may be obtained by adjusting either the coupling, k, between the two coils, or by changing the Q of the circuit L1-C1-R1, or by doing both. If the coupling is fixed, as is often the case, Q must be adjusted to attain a match. Note that increasing the value of Q is equivalent to tightening the coupling, and vice versa.

If L2 does not have the optimum value, the match may still be obtained by adjusting k and Q, but one or the other—or both—must have a larger value than is needed when  $X_{L2}$  is equal to R2. In general, it is desirable to use as low a value of loaded Q as is practical. Low Q values mean that the circuit requires little or no readjustment when shifting frequency within a band (provided the antenna R1 does not vary appreciably with frequency). A low value of loaded Q also means that less loss occurs in the matching network itself.

### Circuit Q

In **Fig 2A**, where a parallel-tuned network is used,  $Q_P$  is equal to

$$Q_P = \frac{R1}{X_{C1}} \quad (\text{Eq 3})$$

This assumes L1-C1 is tuned to the operating frequency. This circuit is suitable for comparatively high values of R1—from several hundred to several thousand ohms.

In **Fig 2C**, which is a series-tuned network, Q is equal to

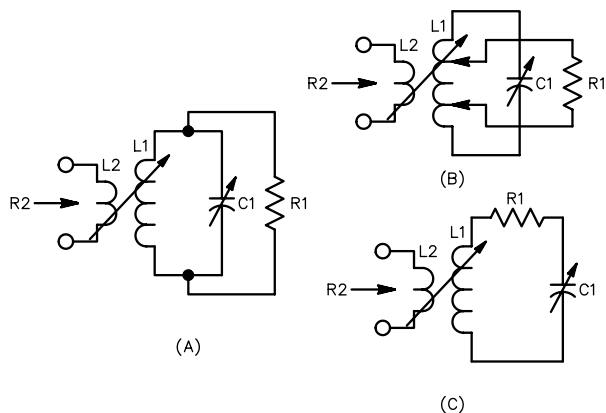
$$Q_S = \frac{X_{C1}}{R1} \quad (\text{Eq 4})$$

Again, we assume that L1-C1 is tuned to the operating frequency. This circuit is suitable for low values of R1—from a few ohms up to a hundred or so ohms. In **Fig 2B** the Q depends on the placement of the taps on L1 as well as on the reactance of C1. This circuit is suitable for matching all values of R1 likely to be encountered in practice.

Note that to change Q in either **Fig 2A** or **Fig 2C**, it is necessary to change the reactance of C1. Since the circuit is tuned essentially to resonance at the operating frequency, this means that the L/C ratio must be varied in order to change Q. In **Fig 2B** a fixed L/C ratio may be used, since Q can be varied by changing the tap positions. The Q will increase as the taps are moved closer together, and will decrease as they are moved farther apart on L1.

### Reactive Loads—Series and Parallel Coupling

More often than not, the load represented by the input impedance of the transmission line is reactive as well as resistive. In such a case the load cannot be represented by a simple resistance, such as R1 in **Fig 2**. As stated in [Chapter 24](#), for any one frequency we have the option of considering the load to be a resistance in parallel with a



**Fig 2—Circuit arrangements for inductively coupled impedance-matching circuit. A and B use a parallel-tuned coupling tank; B is equivalent to A when the taps are at the ends of L1. The series-tuned circuit at C is useful for very low values of load resistance, R1.**



reactance, or as a resistance in series with a reactance. In Fig 2, at A and B, it is convenient to use the parallel equivalent of the line input impedance. The series equivalent is more suitable for Fig 2C.

Thus, in Fig 3A and 3B the load might be represented by R1 in parallel with the capacitive reactance C, and in Fig 3C by R1 in series with a capacitive reactance C. In Fig 3A, the capacitance C is in parallel with C1 and so the total capacitance is the sum of the two. This is the effective capacitance that, with L1, tunes to the operating frequency. Obviously the setting of C1 will be at a lower value of capacitance with such a load than it would with a purely resistive load such as in Fig 2A.

In Fig 3B the capacitance of C also increases the total capacitance effective in tuning the circuit. However, in this case the increase in effective tuning capacitance depends on the positions of the taps. If the taps are close together the effect of C on the tuning is relatively small, but it increases as the taps are moved farther apart.

In Fig 3C, the capacitance C is in series with C1 and so the total capacitance is less than either. Hence the capacitance of C1 must be increased in order to resonate the circuit, as compared with the purely resistive load shown in Fig 2C.

If the reactive component of the load impedance is inductive, similar considerations apply. In such case an inductance would be substituted for the capacitance C shown in Fig 3. The effect in Fig 3A and 3B would be to decrease the effective inductance in the circuit, so C1 would require a

larger value of capacitance in order to resonate the circuit at the operating frequency. In Fig 3C the effective inductance would be increased, thus making it necessary to set C1 at a lower value of capacitance for resonating the circuit.

### Effect of Line Reactance on Circuit Q

The presence of reactance in the line input impedance presented to the matching network can affect the Q of the matching circuit. If the reactance is capacitive, the Q will not change if resonance can be maintained by adjustment of C1 without changing either the value of L1 or the position of the taps in Fig 3B (as compared with the Q when the load is purely resistive and has the same value of resistance, R1). If the load reactance is inductive, the L/C ratio changes because the effective inductance in the circuit is changed and, in the ordinary case, L1 is not adjustable. This increases the Q in all three circuits of Fig 3.

When the load has appreciable reactance, it is not always possible to adjust the circuit to resonance by readjusting C1, as compared with the setting it would have with a purely resistive load. Such a situation may occur when the load reactance is low compared with the resistance in the parallel-equivalent circuit, or when the reactance is high compared with the resistance in the series-equivalent circuit. The very considerable detuning of the circuit that results is often accompanied by an increase in Q, sometimes to values that lead to excessively high circulating currents in the circuit. This causes the efficiency to suffer. (Ordinarily the power loss in matching circuits of this type is inconsequential, if the loaded Q is below 10 and a good coil is used.) An unfavorable ratio of reactance to resistance in the input impedance of the line can exist if the SWR is high and the line length is near an odd multiple of  $\lambda/8$  ( $45^\circ$ ).

### Q of Line Input Impedance

The ratio between reactance and resistance in the equivalent input circuit—that is, the Q of the impedance at the line's input—is a function of line length and SWR. There is no specific value of this Q of which it can be said that lower values are satisfactory while higher values are not. In part, the maximum tolerable value depends on the tuning range available in the matching circuit. If the tuning range is restricted (as it will be if the variable capacitor has relatively low maximum capacitance), compensating for the line input reactance by absorbing it in the matching circuit—that is, by retuning C1 in Fig 3—may not be possible. Also, if the Q of the matching circuit is low, the effect of the line input reactance will be greater than it will when the matching-circuit Q is high.

As stated earlier, the optimum matching-circuit design is one in which the Q is low, that is, a low reactance-to-resistance ratio.

### Compensating for Input Reactance

When the reactance/resistance ratio in the line input impedance is unfavorable, it is advisable to take special steps to compensate for it. This can be done as shown in Fig 4.

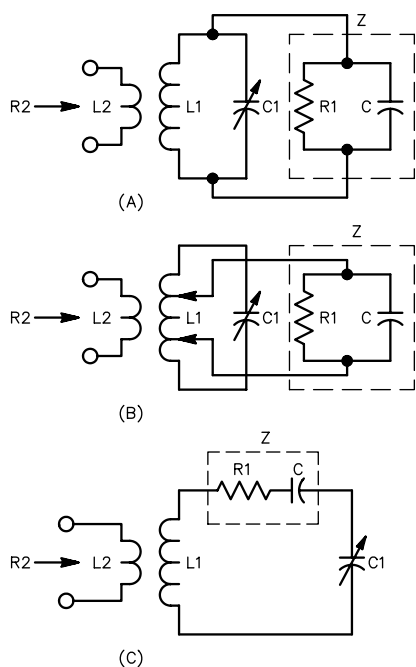


Fig 3—Line input impedances containing both resistance and reactance can be represented as shown enclosed in dashed lines, for capacitive reactance. If the reactance is inductive, a coil is substituted for the capacitance C.

Compensation consists of supplying external reactance of the same numerical value as the line reactance, but of the opposite kind. Thus in Fig 4A, where the line input impedance is represented by resistance and capacitance in parallel, an inductance  $L$  having the same numerical value of reactance as  $C$  can be connected across the line terminals to cancel out the line reactance. (This is actually the same thing as tuning the line to resonance at the operating frequency.) Since the parallel combination of  $L$  and  $C$  is equivalent to an extremely high resistance at resonance, the input impedance of the line becomes a pure resistance having essentially the same resistance as  $R1$  alone.

The case of an inductive line impedance is shown in Fig 4B. In this case the external reactance required is capacitive, of the same numerical value as the reactance of  $L$ . Where the series equivalent of the line input impedance is used, the external reactance is connected in series, as shown at C and D in Fig 4.

In general, these methods are not needed unless the matching circuit has insufficient range of adjustment to provide compensation for the line reactance as described earlier, or when such a large readjustment is required that

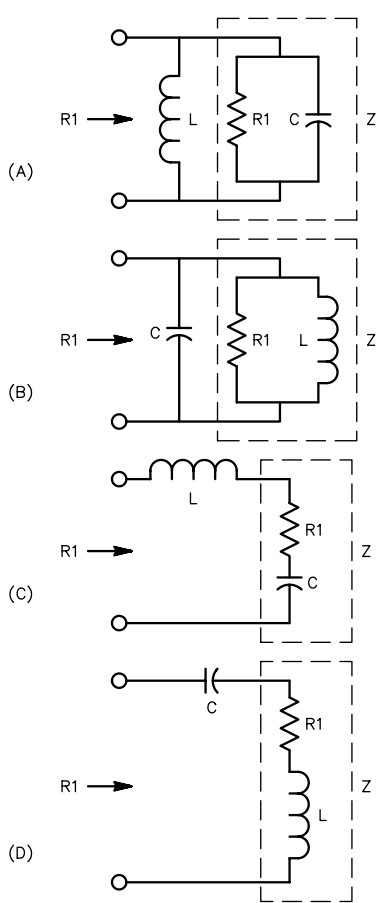


Fig 4—Compensating for reactance present in the line input impedance.

the matching-circuit  $Q$  becomes undesirably high. The latter condition usually is accompanied by heating of the coil used in the matching network.

### Methods for Variable Coupling

The coupling between  $L1$  and  $L2$ , Figs 2 and 3, preferably should be adjustable. If the coupling is fixed, such as with a fixed-position link, the placement of the taps on  $L1$  for proper matching becomes rather critical. The additional matching adjustment afforded by adjustable coupling between the coils facilitates the matching procedure considerably.  $L2$  should be coupled to the center of  $L1$  for the sake of maintaining balance, since the circuit is used with balanced lines.

If adjustable inductive coupling such as a *swinging link* is not feasible for mechanical reasons, an alternative is to use a variable capacitor in series with  $L2$ . This is shown in Fig 5. Varying  $C2$  changes the total reactance of the circuit formed by  $L2$ - $C2$ , with much the same effect as varying the actual mutual inductance between  $L1$  and  $L2$ . The capacitance of  $C2$  should resonate with  $L2$  at the lowest frequency in the band of operation. This calls for a fairly large value of capacitance at low frequencies (about 1000 pF at 3.5 MHz for 50- $\Omega$  line) if the reactance of  $L2$  is equal to the line  $Z_0$ . To utilize a capacitor of more convenient size—maximum capacitance of perhaps 250 to 300 pF—a value of inductance may be used for  $L2$  that will resonate at the lowest frequency with the maximum capacitance available.

On the higher frequency bands the problem of variable capacitors does not arise since a reactance of 50 to 75  $\Omega$  is within the range of conventional components.

### Circuit Balance

Fig 5 shows  $C1$  as a balanced or split-stator capacitor. This type of capacitor is desirable in a practical matching circuit to be used with a balanced line, since the two sections are symmetrical. The rotor assembly of the balanced capacitor may be grounded, if desired, or it may be left *floating* and the center of  $L1$  may be grounded; or both may float. Which method to use depends on considerations discussed later in connection with antenna currents on transmission lines. As an alternative to using a split-stator type of capacitor, a single-section capacitor may be used.

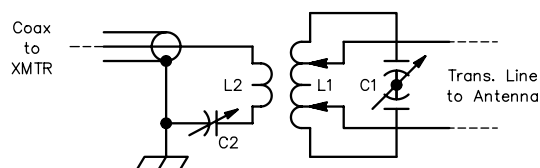


Fig 5—Using a variable capacitance,  $C2$ , as an alternative to variable mutual inductance between  $L1$  and  $L2$ .

## Measurement of Line Input Current

The RF ammeters shown in Fig 6 are not essential to the adjustment procedure but they, or some other form of output indicator, are useful accessories. In most cases the circuit adjustments that lead to a match as shown by the SWR indicator will also result in the most efficient power transfer to the transmission line. However, it is possible that a good match will be accompanied by excessive loss in the matching circuit. This is unlikely to happen if the steps described for obtaining a low Q are taken. If the settings are highly critical or it is impossible to obtain a match, the use of additional reactance compensation as described earlier is indicated.

RF ammeters are useful for showing the comparative output obtained with various matching-network settings, and also for showing the improvement in output resulting from the use of reactance compensation when it seems to be required. Providing no basic circuit changes (such as grounding or ungrounding some part of the matching circuit) are made during such comparisons, the current shown by the ammeters will increase whenever the power put into the line is increased. Thus, the highest reading indicates the greatest transfer efficiency, assuming that the power input to the transmitter is kept constant.

Two ammeters, one in each line conductor, are shown in Fig 6. The use of two instruments gives a check on the line balance, since the currents should be the same. However, a single meter can be switched from one conductor to the other. If only one instrument is used, it is preferably left out of the circuit except when adjustments are being made, since it will add capacitance to the side in which it is inserted and thus cause some unbalance. This is particularly important when the instrument is mounted on a metal panel.

Since the resistive component of the input impedance of a line operating with an appreciable SWR is seldom known accurately (and since the impedance varies with frequency), the RF current is of little value as a check on the exact power input to such a line. However, it shows in a relative way the efficiency of the system as a whole. The set of coupling adjustments that results in the largest line current with the least final-amplifier input power is the most desirable—and most efficient. Just remember that the amount of current into a multiband wire may vary dramatically from one frequency band to the next, since the impedance at the input of the line varies greatly. See Chapter 2.

For adjustment purposes, it is possible to substitute

small flashlight lamps, shunted across a few inches of the line wires, for the RF ammeters. Their relative brightness shows when the current increases or decreases. They have the advantage of being inexpensive and of such small physical size that they do not unbalance the circuit. Another method to measure RF current is to use a toroidal core with a single-turn primary. See the section at the end of Chapter 6 on “lowfer” antenna techniques.

## THE L-NETWORK

A comparatively simple but very useful matching circuit for unbalanced loads is the L-network, as shown in Fig 7A. L-network antenna tuners are normally used for only a single band of operation, although multiband versions with switched or variable coil taps exist. To determine the range of circuit values for a matched condition, the input and load impedance values must be known or assumed. Otherwise a match may be found by trial.

In Fig 7A, L1 is shown as the series reactance,  $X_S$ , and C1 as the shunt or parallel reactance,  $X_P$ . However, a capacitor may be used for the series reactance and an inductor for the shunt reactance, to satisfy mechanical or other considerations.

The ratio of the series reactance to the series resistance,  $X_S/R_S$ , is defined as the network Q. The four variables,  $R_S$ ,  $R_P$ ,  $X_S$  and  $X_P$ , for lossless components are related as given in the equations below. When any two values are known, the other two may be calculated.

$$Q = \sqrt{\frac{R_P}{R_S} - 1} = \frac{X_S}{R_S} = \frac{R_P}{X_P} \quad (\text{Eq 5})$$

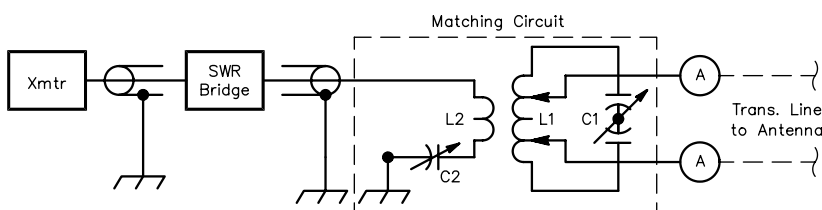
$$X_S = QR_S = \frac{QR_P}{1+Q^2} \quad (\text{Eq 6})$$

$$X_P = \frac{R_P}{Q} = \frac{R_P R_S}{X_S} = \frac{R_S^2 + X_S^2}{X_S} \quad (\text{Eq 7})$$

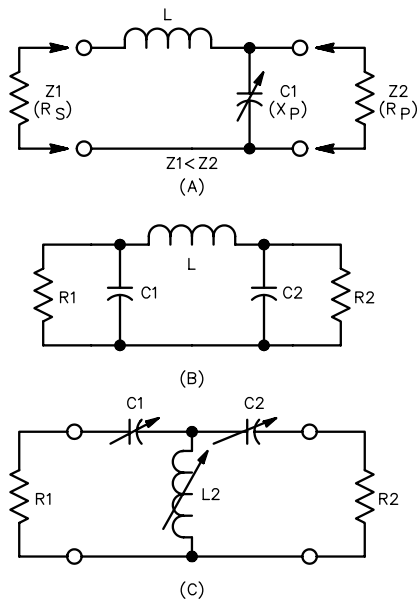
$$R_S = \frac{R_P}{Q^2 + 1} = \frac{X_S X_P}{R_P} \quad (\text{Eq 8})$$

$$R_P = R_S (1 + Q^2) = QX_P = \frac{R_S^2 + X_S^2}{R_S} \quad (\text{Eq 9})$$

The reactance of loads that are not purely resistive may



**Fig 6—Adjustment setup using SWR indicator. A—RF ammeters (see text).**



**Fig 7—At A, the L-matching network, consisting of L1 and C2, to match Z1 and Z2. The lower of the two impedances to be matched, Z1, must always be connected to the series-arm side of the network and the higher impedance, Z2, to the shunt-arm side. The positions of the inductor and capacitor may be interchanged in the network. At B, the Pi-network tuner, matching R1 to R2. The Pi provides more flexibility than the L as an antenna-tuner circuit. See equations in the text for calculating component values. At C, the T-network tuner. This has more flexibility in that components with practical values can match a wide variety of loads. The drawback is that this network can be inefficient, particularly when the output capacitor is small.**

be taken into account and absorbed or compensated for in the reactances of the matching network. Inductive and capacitive reactance values may be converted to inductor and capacitor values for the operating frequency with standard reactance equations.

It is important to recognize that Eq 5, 6, 7, 8 and 9 are for *lossless* components. When real components with real unloaded Qs are used, the transformation changes and you must compensate for the losses. Real coils are represented by a perfect inductor in series with a loss resistance, and real capacitors by a perfect capacitor in parallel with a loss resistance. At HF, a physical coil will have an unloaded  $Q_U$  between 100 and 400, with an average value of about 200 for a high-quality airwound coil mounted in a spacious metal enclosure. A variable capacitor used in an antenna tuner will have an unloaded  $Q_U$  of about 1000 for a typical air-variable capacitor with wiper contacts. An expensive vacuum-variable capacitor can have an unloaded  $Q_U$  as high as 5000.

The power loss in coils is generally larger than in variable capacitors used in practical antenna tuners. The circulating RF current in both coils and capacitors can also cause severe heating. The ARRL Laboratory has seen coils

forms made of plastic melt when pushing antenna tuners to their extreme limits during product testing. The RF voltages developed across the capacitors can be pretty spectacular at times, leading to severe arcing.

The ARRL program *TLW* (Transmission Line for Windows) on the CD-ROM included with this book does calculations for transmission lines and antenna tuners. *TLW* evaluates four different networks: a low-pass L-network, a high-pass L-network, a low-pass Pi-network, and a high-pass T-network. Not only does *TLW* compute the exact values for network components, but also the full effects of voltage, current and power dissipation for each component. Depending on the load impedance presented to the antenna tuner, the internal losses in an antenna tuner can be disastrous. See the documentation file TLW.DOC for further details on the use of *TLW*, which some call the “Swiss Army Knife” of transmission-line software.

### THE PI-NETWORK

The impedances at the feed point of an antenna used on multiple HF bands varies over a very wide range, particularly if thin wire is used. This was described in detail in Chapter 2. The transmission line feeding the antenna transforms the wide range of impedances at the antenna’s feed point to another wide range of impedances at the transmission line’s input. This often mandates the use of a more flexible antenna tuner than an L-network.

The Pi-network, shown in Fig 7B, offers more flexibility than the L-network, since there are three variables to instead of two. The only limitation on the circuit values that may be used is that the reactance of the series arm, the inductor L in the figure, must not be greater than the square root of the product of the two values of resistive impedance to be matched. The following equations are for lossless components in a Pi-network.

For  $R_1 > R_2$

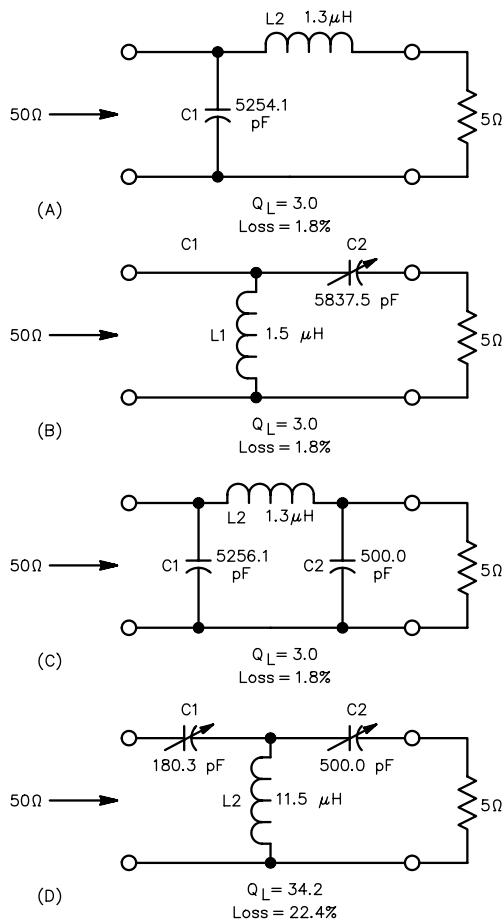
$$X_{C1} = \frac{R_1}{Q} \quad (\text{Eq 10})$$

$$X_{C2} = R_2 \sqrt{\frac{R_1/R_2}{Q^2 + 1 - R_1/R_2}} \quad (\text{Eq 11})$$

$$X_L = \frac{(Q \times R_1) + \frac{R_1 \times R_2}{X_{C2}}}{Q^2 + 1} \quad (\text{Eq 12})$$

The Pi-network may be used to match a low impedance to a rather high one, such as 50 to several thousand ohms. Conversely, it may be used to match 50  $\Omega$  to a quite low value, such as 1  $\Omega$  or less. For antenna-tuner applications, C1 and C2 may be independently variable. L may be a roller inductor or a coil with switchable taps.

Alternatively, a lead fitted with a suitable clip may be used to short out turns of a fixed inductor. In this way, a match may be obtained through trial. It will be possible to



**Fig 8—Computed values for real components ( $Q_U = 200$  for coil,  $Q_U = 1000$  for capacitor) to match 5- $\Omega$  load resistance to 50- $\Omega$  line. At A, low-pass L-network, with shunt input capacitor, series inductor. At B, high-pass L-network, with shunt input inductor, series capacitor. Note how large the capacity is for these L-networks. At C, low-pass Pi-network and at D, high-pass T-network. The component values for the T-network are practical, although the loss is highest for this particular network, at 22.4% of the input power.**

match two values of impedances with several different settings of L, C1 and C2. This results because the Q of the network is being changed. If a match is maintained with other adjustments, the Q of the circuit rises with increased capacitance at C1.

Of course, the load usually has a reactive component along with resistance. You can compensate for the effect of these reactive components by changing one of the reactive elements in the matching network. For example, if some reactance was shunted across R2, the setting of C2 could be changed to compensate, whether that shunt reactance be inductive or capacitive.

As with the L-network, the effects of real-world unloaded Q for each component must be taken into account in the Pi-network to evaluate real-world losses.

## THE T-NETWORK

Both the Pi-network and the L-network often require unwieldy values of capacitance—that is, *large* capacitances are often required at the lower frequencies—to make the desired transformation to 50  $\Omega$ . Often, the range of capacitance from minimum to maximum must be quite wide when the impedance at the output of the network varies radically with frequency, as is common for multiband, single-wire antennas.

The high-pass T-network shown in Fig 7C is capable of matching a wide range of load impedances and uses practical values for the components. However, as in almost everything in radio, there is a price to be paid for this flexibility. The T-network can be very lossy compared to other network types. This is particularly true at the lower frequencies, whenever the load resistance is low. Loss can be severe if the maximum capacitance of the output capacitor C3 in Fig 7C is low.

For example, Fig 8 shows the computed values for the components at 1.8 MHz for four types of networks into a load of 5 + j0  $\Omega$ . In each case, the unloaded Q of the inductor used is assumed to be 200, and the unloaded Q of the capacitor(s) used is 1000. The component values were computed using the program *TLW*.

Fig 8A is a low-pass L-network; Fig 8B is a high-pass L-network and Fig 8C is a Pi-network. At more than 5200 pF, the capacitance values are pretty unwieldy for the first three networks. The loaded  $Q_L$  for all three is only 3.0, indicating that the network loss is small. In fact, the loss is only 1.8% for all three because the loaded  $Q_L$  is much smaller than the unloaded  $Q_U$  of the components used.

The T-network in Fig 8D uses more practical, realizable component values. Note that the output capacitor C3 has been set to 500 pF and that dictates the values for the other two components. The drawback is that the loaded Q in this configuration has risen to 34.2, with an attendant loss of 22.4% of the power delivered to the input of the network. For the legal limit of 1500 W, the loss in the network is 335 W. Of this, 280 W ends up in the inductor, which will probably melt! Even if the inductor doesn't burn up, the output capacitor C3 might well arc over, since it has more than 3800 V peak across it at 1500 W into the network.

Due to the losses in the components in a T-network, it is quite possible to “load it up into itself,” causing real damage inside. For example, see Fig 9, where a T-network is loaded up into a short circuit at 1.8 MHz. The component values look quite reasonable, but unfortunately *all* the power is dissipated in the network itself. The current through the output capacitor C3 at 1500 W input to the antenna tuner would be 35 A, creating a peak voltage of more than 8700 V across C3. Either C1 (also at more than 8700 V peak) or C3 will probably arc over before the power loss is sufficient to destroy the coil. However, the loud arcing might frighten the operator pretty badly.

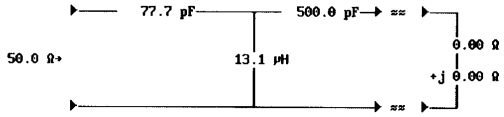
The point you should remember is that the T-network is indeed very flexible in terms of matching to a wide variety

```

TLA, Ver. 4.00AE, Copyright 1993-1997, ARRL -- by N6BV
Frequency = 1.830 MHz
Transmission line: 450-Ohm Window Ladder Line, Length: 0.00 ft
At Antenna Tuner output: 0.00 + j 0.00 Ω = 0.00 R at 0.00°
Highest network effective Q = 999.9
Est. power lost in tuner for 1500 W = 1500 W (50.81 dB = 100.00% lost)
Xasn-line loss: 0.00 dB; Total loss: 50.81 dB. Into load: 0.0 W

```

At 1500 W	Cin	L	Out
Unloaded Q	1000	200	1000
Reactance	-1119.115 Ω	150.577 Ω	-173.940 Ω
Peak Voltage	8669 V	8677 V	8677 V
RMS Current	5.5 A	40.7 A	35.3 A
Power Diss.	34 W	1250 W	216 W



Z (Z), Cs [C], Freq.(F), Defaults (D), Network (N, 1-4), Main (M), Exit (X): █

**Fig 9—Screen print of TLA program (a DOS predecessor of TLW) for a T-network antenna tuner with short at output terminals. The tuner has been “loaded up into itself,” dissipating all input power internally!**

of loads. However, it must be used judiciously, lest it burn itself up. Even if it doesn't fry itself, it can waste that precious RF power you'd rather put into your antenna.

### THE AAT (ANALYZE ANTENNA TUNER) PROGRAM

As you might expect, the limitations imposed by practical components used in actual antenna tuners depends on the individual component ratings, as well as on the range of impedances presented to the tuner for matching. ARRL has developed a program called *AAT*, standing for “Analyze Antenna Tuner,” to map the range over which a particular design can achieve a match without exceeding certain operator-selected limits. *AAT* is included with the software on the CD-ROM in the back of this book.

Let's assume that you want to evaluate a T-network on the ham bands between 1.8 to 29.7 MHz. First, you select suitable variable capacitors for C1 and C3. You decide to try the popular Johnson 154-16-1, which is rated for a minimum to maximum range from 32 to 241 pF, at 4500 V peak. Stray capacity in the circuit is estimated at 10 pF, making the actual range from 42 to 251 pF, with an unloaded Q of 1000. This value of Q is typical for an air-variable capacitor with wiping contacts. Next, you choose a variable inductor with a maximum inductance of, let's say, 28 μH and an unloaded Q of 200, again typical values for a practical inductor. Set a power-loss limit of 20%, equivalent to a power loss of about 1 dB. Then you let *AAT* do its computations.

*AAT* tests matching capability over a very wide range of load impedances, in octave steps of both resistance and reactance. For example, it starts out with 3.125 - j 3200 Ω, and checks whether a match is possible. It then proceeds to 3.125 - j 1600 Ω, 3.125 - j 800 Ω, etc, down to 3.125 + j 0 Ω. Then *AAT* checks matching with positive reactances: 3.125 + j 3.125, 3.125 + j 6.25, 3.125 + j 12.5, etc. on up to 3.125 + j 3200 Ω. Then it repeats the same process, over the

same range of negative and positive reactances, for a series resistance of 6.25 Ω. It continues this process in octave steps of resistance, all the way up to 3200 Ω resistive. A total of 253 impedances are thus checked for each frequency, giving a total of 2,277 combinations for all nine amateur bands from 1.8 to 29.7 MHz.

If the program determines that the chosen network can match a particular impedance value, while staying within the limits of voltage, component values and power loss imposed by the operator, it stores the lost-power percentage in memory and proceeds to the next impedance. If *AAT* determines that a match is possible, but some parameter is violated (for example, the voltage limit is exceeded), it stores the out-of-specification problem to memory and tries the next impedance.

For the Pi-network and the T-network, which have three variable components, the program varies the output capacitor in discrete steps of capacitance. It is possible for *AAT* to miss very critical matching combinations because of the size of the steps necessary to hold execution time down. You can sometimes find such critical matching points manually using the *TLW* program, which uses the same algorithms to determine matching conditions. On a 100-MHz Pentium, *AAT* takes almost four minutes to evaluate all 2,277 combinations for the default component values. On a 33-MHz 486DX machine it really seems to crawl. Because of such execution-time considerations, *AAT* does an *extensive* search, but not an *exhaustive* one.

Once all impedance points have been tried, *AAT* writes the results to two disk files—one is a summary file (TEENET.SUM, in this example) and the other is a detailed log (TEENET.LOG) of successful matches, and matches that came close except for exceeding a voltage rating. **Fig 10** is a sample printout of part of the summary *AAT* output for the 3.5 MHz band and one for the 29.7 MHz band. (The printouts for 1.8 MHz, and the bands from 7.1 to 24.9 MHz are not shown here.) This is for a T-network whose variable capacitors C1 and C3 (including 10 pF stray) range from 42 to 251 pF, each with a voltage rating of 4500 V. The coil is assumed to go up to 28 μH and has an unloaded Q of 200.

The numbers in the matching map grid represent the power loss percentage for each impedance where a match is indeed possible. Where a “C-” appears, *AAT* is saying that a match can't be made because the minimum capacity of one or the other variable capacitors is too large. This often happens on the higher frequency bands, but can occur on the lower bands when the power loss is greater than the specified limit and *AAT* continues to try to find a condition where the power loss is lower. It does this until it runs into the minimum-capacitance limit of the input capacitor C1.

Similarly, where a “C+” appears, a match can't be made because the maximum capacity of one or the other variable capacitors is too small. Where an “L+” is placed in the grid, the match fails because more inductance is needed. Where a “V” is shown, the voltage limit for some component has been exceeded. It may be possible in such a circumstance to

```

Loss percentage for Tee-network, series cap., shunt inductor, series cap.
Freq: 3.5 MHz, Z0: 50, 1500W, Vmax: 4500 V, Qu: 200, Qc: 1000
Var. Cap: 42 to 251 pF with switched 160/80 m output cap.: 0 pF
  Xa  3.125 6.25 12.5 25 50 100 200 400 800 1600 3200 Ra
- 3200 L+ L+ L+ L+ L+ L+ L+ L+ L+ V 7.2
- 1600 L+ L+ L+ L+ L+ L+ V V V 6.7 5.4 5.6
- 800 L+ L+ C- C- V V 8.1 5.5 4.3 4.2 5.0
- 400 C- C- C- V 12.0 7.6 5.0 3.6 3.2 3.7 4.8
- 200 C- C- P 13.3 8.2 5.2 3.5 2.7 2.8 3.5 4.7
- 100 C- C- 16.7 10.2 6.3 3.9 3.1 2.9 2.6 3.4 4.7
- 50 C- C- 14.3 8.6 5.2 3.6 3.3 2.9 2.6 3.4 4.7
- 25 C- C- 13.1 7.8 4.7 3.6 3.1 2.8 2.5 3.4 4.7
- 12.5 C- C- 12.4 7.4 4.5 3.9 3.5 2.8 2.5 3.4 4.7
- 6.25 C- C- 12.1 7.2 4.4 3.8 3.5 2.7 2.5 3.4 4.7
-3.125 C- 19.8 11.9 7.1 4.7 3.8 3.5 2.7 2.5 3.4 4.7
  0 C- 19.6 11.8 7.0 4.7 3.7 3.4 2.7 2.5 3.4 4.7
  3.125 C- 19.3 11.6 6.9 4.6 3.7 3.4 2.7 2.5 3.4 4.7
  6.25 C- 19.1 11.4 6.8 4.5 3.7 3.4 2.9 2.5 3.4 4.7
  12.5 C- 18.6 11.1 6.6 4.4 4.2 3.3 2.9 2.5 3.4 4.7
  25 C- 17.6 10.4 6.2 4.7 4.0 3.2 2.8 2.5 3.4 4.7
  50 C- 15.5 9.1 6.1 4.9 3.7 3.4 2.7 2.4 3.3 4.7
  100 P 11.0 7.6 6.5 4.9 3.9 3.4 2.9 2.4 3.3 4.7
  200 V V 8.3 7.0 5.3 3.9 3.6 2.8 2.3 3.3 4.7
  400 P V V V V 5.4 3.6 3.5 2.3 3.3 4.6
  800 P P P V V V 2.3 2.3 2.6 3.4 4.7
 1600 L+ 2.5 3.6 3.9 4.0 4.9
 3200 L+ L+ L+ L+ 5.5 5.9

```

```

Loss percentage for Tee-network, series cap., shunt inductor, series cap.
Freq: 29.7 MHz, Z0: 50, 1500W, Vmax: 4500 V, Qu: 200, Qc: 1000
Var. Cap: 42 to 251 pF with switched 160/80 m output cap.: 0 pF
  Xa  3.125 6.25 12.5 25 50 100 200 400 800 1600 3200 Ra
- 3200 C- C- C- C- C- C- C- C- C- C- C-
- 1600 C- C- C- C- C- C- C- C- C- C- C-
- 800 C- C- C- C- C- C- C- C- C- C- C-
- 400 C- C- C- C- C- C- C- C- C- C- C-
- 200 C- C- C- C- C- C- C- C- C- C- C-
- 100 C- C- C- C- 2.7 1.8 1.6 C- C- C- C-
- 50 C- C- C- 2.6 1.6 1.2 1.3 C- C- C- C-
- 25 C- 5.3 2.9 1.7 1.1 1.0 1.2 C- C- C- C-
- 12.5 7.1 3.9 2.1 1.1 0.8 0.9 1.1 C- C- C- C-
- 6.25 6.0 3.2 1.7 1.0 0.6 0.8 1.1 C- C- C- C-
-3.125 5.4 2.8 1.4 1.0 0.6 0.8 1.1 C- C- C- C-
  0 4.7 2.5 1.6 1.0 0.6 0.8 1.1 C- C- C- C-
  3.125 4.1 2.4 1.7 1.1 0.6 0.7 1.1 C- C- C- C-
  6.25 3.4 2.4 1.5 1.0 0.6 0.7 1.1 C- C- C- C-
  12.5 3.4 2.9 2.0 1.1 0.6 0.7 1.1 C- C- C- C-
  25 4.6 3.2 2.0 1.3 0.6 0.6 1.0 C- C- C- C-
  50 5.2 3.9 2.0 1.6 0.7 0.5 1.0 C- C- C- C-
  100 8.9 4.8 2.5 C+ 0.9 0.5 1.0 C- C- C- C-
  200 0.7 1.1 C- C- C- C-
  400 C- C- C- C- C- C-
  800 C- C- C- C- C- C-
 1600 C- C- C- C- C- C-
 3200 L+ C- C- C- C- C-

```

**Fig 10—Sample printout from the AAT program, showing 3.5 and 29.7-MHz simulations for a T-network antenna tuner using 42-251 pF variable tuning capacitors (including 10 pF of stray), with voltage rating of 4500 V and 28  $\mu$ H roller inductor. The load varies from 3.125 - j 3200  $\Omega$  to 3200 + j 3200  $\Omega$  in geometric steps. Symbol “L+” indicates that a match is impossible because more inductance is needed. “C-” indicates that the minimum capacity is too large. “V” indicates that the voltage rating of a capacitor has been exceeded. “P” indicates that the power rating limit set by the operator to 20% has been exceeded. A blank indicates that matching is not possible at all, probably for a variety of simultaneous reasons.**

Loss percentage for Tee-network, series cap., shunt inductor, series cap.  
 Freq: 3.5 MHz, Z0: 50, 1500W, Vmax: 3000 V, Qu: 200, Qc: 1000  
 Var. Cap: 25 to 402 pF with switched 160/80 m output cap.: 400 pF

Xa	3.125	6.25	12.5	25	50	100	200	400	800	1600	3200	Ra
- 3200	L+	L+	L+	L+		L+	L+	L+	L+	V	V	
- 1600	L+	L+	L+	L+		L+	V	V	V	V	V	
- 800	C-	L+	L+	L+	V	V	V	4.9	3.9	4.0	V	
- 400	C-	L+	L+	V	V	6.0	4.0	3.0	2.9	3.6	V	
- 200	C-	L+	V	9.0	5.5	3.5	2.5	2.2	2.6	3.4	V	
- 100	C-	V	9.6	5.7	3.5	2.3	1.8	1.9	2.4	3.4	V	
- 50	19.7	11.7	6.8	4.0	2.6	2.2	1.8	1.8	2.4	3.3	V	
- 25	16.1	9.3	5.4	3.3	2.7	2.3	1.8	1.7	2.4	3.3	V	
- 12.5	14.1	8.1	4.6	3.4	2.9	2.4	1.9	1.7	2.4	3.3	V	
- 6.25	13.1	7.5	4.2	3.5	2.8	2.4	1.9	1.7	2.3	3.3	V	
-3.125	12.6	7.2	4.3	3.3	2.7	2.3	1.8	1.7	2.3	3.3	V	
0	12.1	6.9	4.4	3.6	3.0	2.3	1.8	1.7	2.3	3.3	V	
3.125	11.6	6.5	4.6	3.4	3.0	2.3	2.0	1.7	2.3	3.3	V	
6.25	11.0	6.2	4.4	3.7	2.9	2.6	2.0	1.7	2.3	3.3	V	
12.5	10.0	6.0	4.4	3.5	2.8	2.5	1.9	1.7	2.3	3.3	V	
25	8.5	5.8	4.7	3.6	3.0	2.4	1.9	1.6	2.3	3.3	V	
50	8.6	6.9	4.7	4.2	3.2	2.3	1.8	1.6	2.3	3.3	V	
100	V	V	6.3	4.4	3.2	2.5	1.9	1.5	2.3	3.3	V	
200	V	V	V	V	4.2	2.6	2.0	1.5	2.3	3.3	V	
400	P	V	V	V	V	1.1	1.5	1.7	2.3	3.3	V	
800	P	P	P	V	V	V	2.3	2.6	2.7	3.4	V	
1600	P	P	P	V	V	V	V	V	V	4.1	V	
3200						L+	L+	L+	V	V	V	

Loss percentage for Tee-network, series cap., shunt inductor, series cap.  
 Freq: 29.7 MHz, Z0: 50, 1500W, Vmax: 3000 V, Qu: 200, Qc: 1000  
 Var. Cap: 25 to 402 pF with switched 160/80 m output cap.: 400 pF

Xa	3.125	6.25	12.5	25	50	100	200	400	800	1600	3200	Ra
- 3200	C-	C-	C-	C-		C-	C-	C-	C-	C-	C-	
- 1600	C-	C-	C-	C-	C-	C-	C-	C-	C-	C-	C-	
- 800	C-	C-	C-	C-	C-	C-	C-	C-	C-	C-	C-	
- 400	C-	C-	C-	C-	C-	C-	C-	2.8	C-	C-	C-	
- 200	C-	C-	C-	C-	4.6	2.9	2.2	2.1	2.5	C-	C-	
- 100	C-	C-	C-	4.1	2.5	1.7	1.5	1.8	2.4	C-	C-	
- 50	C-	6.9	3.9	2.3	1.4	1.1	1.3	1.7	2.3	C-	C-	
- 25	7.7	4.3	2.4	1.3	0.9	0.9	1.2	1.6	2.3	C-	C-	
- 12.5	5.4	2.9	1.5	0.8	0.6	0.8	1.1	1.6	2.3	C-	C-	
- 6.25	4.1	2.1	1.3	0.8	0.5	0.7	1.1	1.6	2.3	C-	C-	
-3.125	3.5	1.9	1.4	0.8	0.4	0.7	1.1	1.6	2.3	C-	C-	
0	2.8	1.9	1.4	1.0	0.4	0.7	1.1	1.6	2.3	C-	C-	
3.125	3.2	2.0	1.4	0.9	0.4	0.7	1.1	1.6	2.3	C-	C-	
6.25	3.4	1.9	1.5	1.0	0.4	0.6	1.1	1.6	2.3	C-	C-	
12.5	3.4	2.1	1.4	1.1	0.4	0.6	1.0	1.6	2.3	C-	C-	
25	4.6	2.3	1.5	1.0	0.5	0.6	1.0	1.6	2.3	C-	C-	
50	5.2	3.9	2.0	1.6	0.5	0.5	1.0	1.5	2.3	C-	C-	
100	V	5.6	3.0	1.6	1.0	0.5	0.9	1.5	2.3	C-	C-	
200	V				0.7	0.8	1.1	1.5	2.2	C-	C-	
400						1.2	1.6	1.8	2.3	C-	C-	
800						C-	C-	C-	C-	C-	C-	
1600						C-	C-	C-	C-	C-	C-	
3200						L+	C-	C-	C-	C-	C-	

Fig 11—Another sample AAT program printout, using a dual-section variable capacitor whose overall tuning range when in parallel varies from 25 to 402 pF, but with a 3000-V rating. The same 28  $\mu$ H roller is used, but an auxiliary 400 pF fixed capacitor can now be manually switched across the output variable capacitor. Note that the overall matching range has in effect been shifted over to the left from that in Fig 10 for the lower frequency because the maximum output capacitance is higher. The range has been extended on the highest frequency because the minimum capacitance is smaller.



reduce the power to eliminate arcing. Where “P” is shown, the power limit has been exceeded, meaning that the loss would be excessive. Where a blank occurs, no combination of matching components resulted in a match.

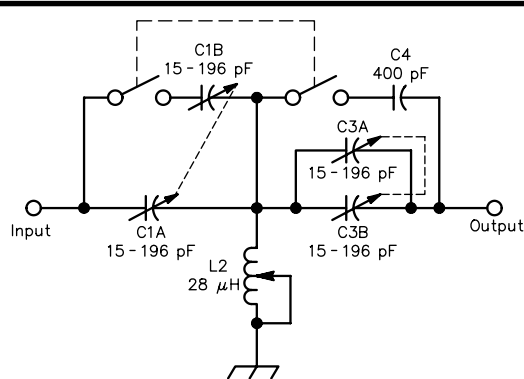
It should be clear that with this particular set of capacitors, the T-network suffers large losses when the load resistance is less than about  $12.5 \Omega$  at 3.5 MHz. For example, for a load impedance of  $12.5 - j 100 \Omega$  the loss is 16.7%. At 1500 W into the tuner, 250 W would be burned up inside, mainly in the coil. It should also be clear that as the reactance increases, the power loss increases, particularly for capacitive reactance. This occurs because the series capacitive reactance of the load adds to the series reactance of C3, and losses rise accordingly.

For most loads, a larger value for the output capacitor C3 decreases losses. Typically, there is a tradeoff between the range of minimum-to-maximum capacity and the voltage rating for the variable capacitors that determines the effective impedance-matching range. See Fig 11, which assumes that capacitors C1 and C3 have a larger range between minimum to maximum capacity, but with a lower peak voltage rating. Each tuning capacitor is representative of a Johnson 154-507-1 dual-section capacitor, which has a range from 15 to 196 pF in each section, at a peak voltage rating of 3000 V. The two sections are placed in parallel for the lower frequencies. Again, a stray capacitance of 10 pF is assumed for each variable capacitor.

The result at 3.5 MHz in Fig 11 is a shift of the matching map toward the left. This means that lower values of series load resistance can be matched with lower power loss. However, it also means that the highest value of load resistance,  $3200 \Omega$ , now runs into the limitation of the voltage rating of the output capacitor, something that did not happen when the 4500-V capacitors were used in Fig 10.

Now, compare Fig 10 and Fig 11 at 29.7 MHz. The smaller minimum capacity (25 pF) of the capacitors in Fig 11 allows for a wider range of matching impedance, compared with the circuit of Fig 10, where the minimum capacity is 42 pF. This circuit can't match loads with resistances greater than  $200 \Omega$ .

Note that AAT also allows the operator to specify a switchable fixed-value capacitor across the output capacitor C3 to aid in matching low-resistance loads on the lower



**Fig 12—Schematic for the T-network antenna tuner whose tuning range is shown in Fig 11.**

frequency bands. In Fig 11, a 400 pF fixed capacitor C4 was assumed to be switched across C3 for the 1.8 and 3.5 MHz bands. Fig 12 shows the schematic for such a T-network antenna tuner.

The power loss in Fig 11 on 3.5 MHz at a load of  $6.25 - j 3.125 \Omega$  is 7.2%, while in Fig 10 the loss is 19.7%. On the other hand, the voltage rating of one (or both) capacitors is exceeded for a load with a  $3200 \Omega$  resistance. By the way, it isn't exceeded by very much: the computed voltage is 3003 V at 1500 W input, just barely exceeding the 3000-V rating for the capacitor. This is, after all, a strictly literal computer program. Turning down the power just a small amount would stop any arcing.

AAT produces similar tables for Pi-network and L-network configurations, mapping the matching capabilities for the component combinations chosen. All computations are, of course, only as accurate as the assumed values for unloaded  $Q_U$  in the components. The unloaded  $Q_U$  of variable inductors can vary quite a bit over the full amateur MF and HF frequency range. Computations produced by AAT have been compared to measured results on real antenna tuners and they correlate well when measured values for unloaded inductor  $Q_U$  are plugged into AAT. Individual antenna tuners may well vary, depending on what sort of stray inductance or capacitance is introduced during construction.

## A Low-Power Link-Coupled Antenna Tuner

Link coupling offers many advantages over other types of systems where a direct connection between the transmitter and antenna is required, using a balanced type of transmission line. This is particularly true at 3.5 MHz, where commercial broadcast stations often induce sufficient voltage to cause either rectification or front-end overload. Transceivers and receivers that show this tendency can usually be cured by using only magnetic coupling between the

transceiver and antenna system. There is no direct connection, and better isolation results, along with the inherent band-pass characteristics of magnetically coupled tuned circuits.

Although link coupling can be used with either single-ended or balanced antenna systems, its most common application is with balanced feed. The model shown here is designed for 3.5- through 28-MHz operation.

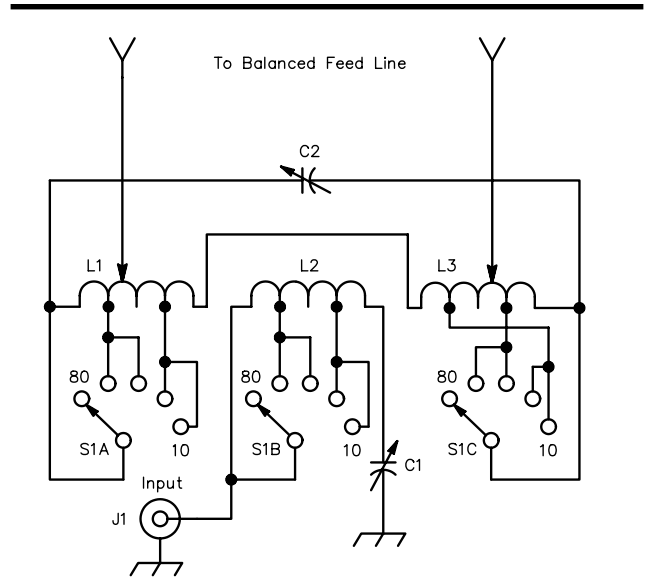
## The Circuit

The antenna tuner network shown in **Figs 13, 14 and 15** is a band-switched link coupler. L2 is the link and C1 is used to adjust the coupling. S1B selects the proper amount of link inductance for each band. L1 and L3 are located on each side of the link and are the coils to which the antenna is connected. Alligator clips are used to connect the antenna to the coil because antennas of different impedances must be connected at different points (taps) along the coil. Also, with most antennas it will be necessary to change taps for different bands of operation. C2 tunes L1 and L3 to resonance at the operating frequency.

Switch sections S1A and S1C select the amount of inductance necessary for each of the HF bands. The inductance of each of the coils has been optimized for antennas in the impedance range of roughly 20 to 600  $\Omega$ . Antennas that exhibit impedances well outside this range may require that some of the fixed connections to L1 and L3 be changed. Should this be necessary, remember that the L1 and L3 sections must be kept symmetrical—the same number of turns on each coil.

## Construction

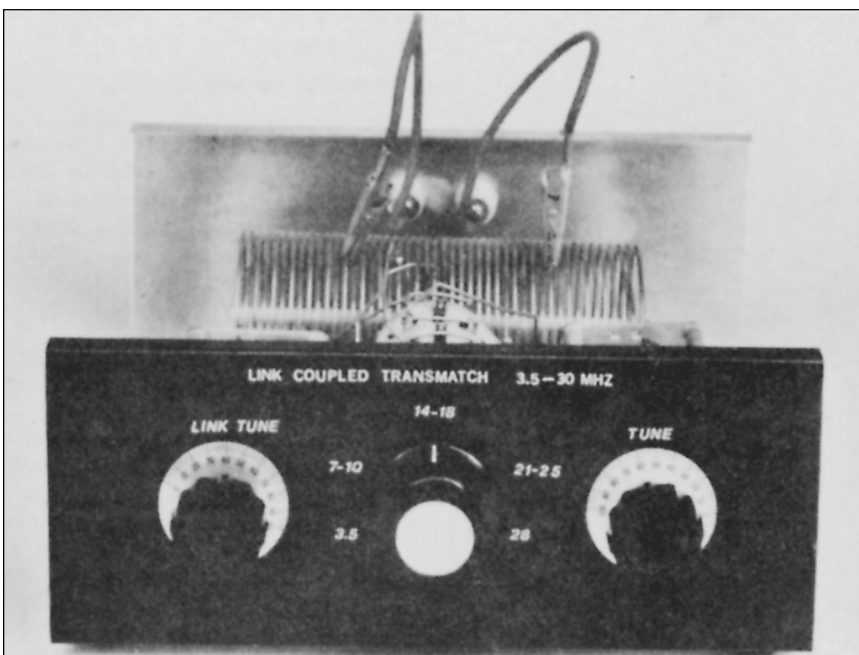
The unit is housed in a homemade aluminum enclosure that measures  $9 \times 8 \times 3\frac{1}{2}$  inches. As can be seen from the schematic, C2 must be isolated from ground. This can be accomplished by mounting the capacitor on steatite cones or other suitable insulating material. Make sure that the hole through the front panel for the shaft of C2 is large enough so the shaft does not make contact with the chassis.



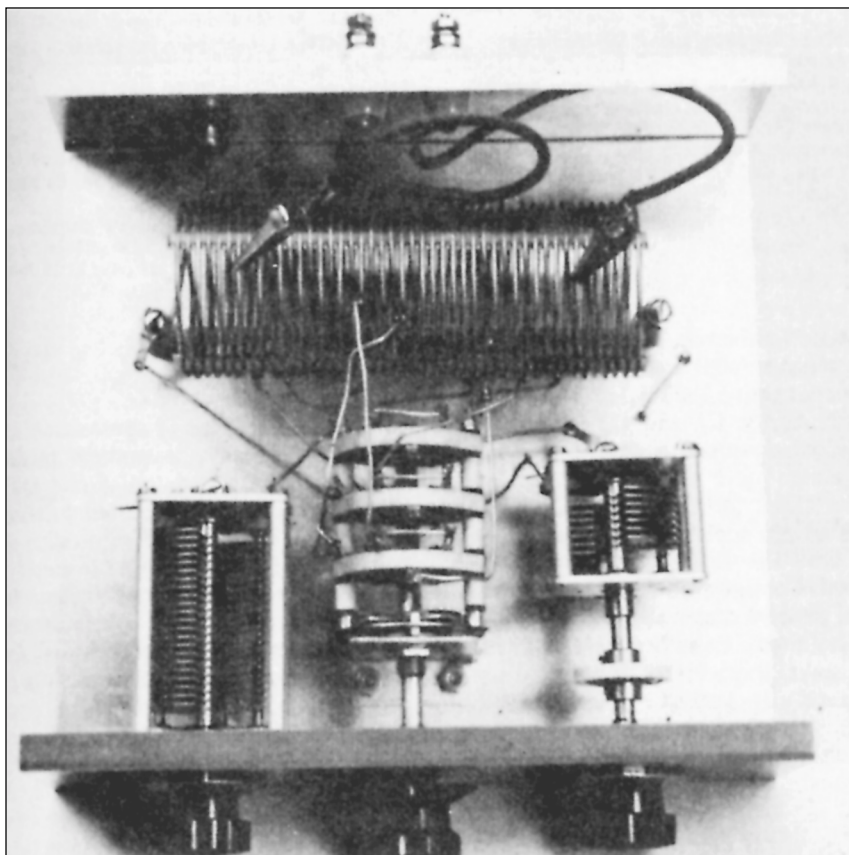
**Fig 14—Schematic diagram of the link coupler. The connections marked as “to balanced feed line” are seatite feedthrough insulators. The arrows on the other ends of these connections are alligator clips.**

**C1—350 pF maximum, 0.0435-in. plate spacing or greater. C2—100 pF maximum, 0.0435-in. plate spacing or greater. J1—Coaxial connector.**

**L1, L2, L3—B&W 3026 Miniductor stock, 2-in. diameter, 8 turns per inch, #14 wire. Coils assembly consists of 48 turns, L1 and L3 are each 17 turns tapped at 8 and 11 turns from outside ends. L2 is 14 turns tapped at 8 and 12 turns from C1 end. See text for additional details. S1—3-pole, 5-position ceramic rotary switch.**



**Fig 13—Exterior view of the band-switched link coupler. Alligator clips are used to select the proper tap positions of the coil.**



**Fig 15—Interior view of the link-coupled tuner, showing the basic positions of the major components. Component placement is not critical, but the unit should be laid out for minimum lead lengths.**

### Tune-Up

The transmitter should be connected to the input of the antenna tuner through some sort of instrument that will indicate SWR. Set S1 to the band of operation, and connect the balanced line to the insulators on the rear panel of the coupler. Attach alligator clips to the mid points of coils L1 and L3, and apply power. Adjust C1 and C2 for minimum reflected power. If a good match is not obtained, move the

antenna tap points either closer to the ends or center of the coils. Again apply power and tune C1 and C2 until the best possible match is obtained. Continue moving the antenna taps until a 1:1 match is obtained.

The circuit described here is intended for power levels up to roughly 200 W. Balance was checked by means of two RF ammeters, one in each leg of the feed line. Results showed the balance to be well within 1 dB.

## High-Power ARRL Antenna Tuner for Balanced or Unbalanced Lines

Only rarely does a transmission line connect at one end to a real-world antenna that has an impedance of exactly 50  $\Omega$ . An antenna tuner is often used to transform whatever impedance results at the input to the transmission line to the 50  $\Omega$  needed by a modern transceiver. Generally, only when a transceiver is working into the load for which it was designed can it deliver its rated power, at its rated level of distortion. Many transceivers have built-in antenna tuners capable of handling a modest range of impedance mismatches. Most are rated for SWRs up to 3:1 on an unbalanced coax line. Such a built-in tuner will probably work fine when you use the transceiver by itself. Thus, if your transceiver has a built-in

antenna tuner and if you use coax-fed antennas, you probably don't need an external antenna tuner.

### REASONS FOR USING AN ANTENNA TUNER

If you use a linear amplifier, however, you may find that it can't load some coax-fed antennas with even moderate SWRs, particularly on 160 or 80 meters. This is usually due to a loading capacitor that is marginal in capability. Some amplifiers even have protective circuits that prevent you from using the amplifier when the SWR is higher than about 2:1. For this situation you may well need a high-power antenna tuner. Bear in mind that although an antenna tuner will bring

the SWR down to 1:1 at the amplifier—that is, it presents a 50-W load to the amplifier—it will not change the actual SWR condition on the transmission line going to the antenna itself. Fortunately, most amateur HF coax-fed antennas are operated close to resonance and any additional loss on the line due to SWR is not a big problem. If you wish to operate a single-wire antenna on multiple frequency bands, an antenna tuner also will be needed. As an example, if you choose a 130-foot long dipole for this task, fed in the center with 450-W ladder line, the feed-point impedance of this antenna over the 1.8 to 29.7-MHz range will vary drastically. Further, the antenna and the feed line are both balanced, requiring a balanced type of antenna tuner. What you need is a balanced antenna tuner that can handle a very wide range of impedances, all without arcing or overheating internally.

### DESIGN PHILOSOPHY BEHIND THE ARRL HIGH-POWER TUNER

Dean Straw, N6BV, designed this antenna tuner with three objectives in mind: First, it would operate over a wide range of loads, at full legal power. Second, it would be a high efficiency design, with minimal losses, including losses in the balun. This led to the third objective: Include a balun operating within its design impedances. Often, a balun is added to the output of a tuner. If it is designed as a 4:1 unit, it expects to see 200  $\Omega$  on its output. Connect it to ladder line and let it see a 1000- $\Omega$  load, and spectacular arcing can occur even at moderate (100 W) power levels.

For that reason this unit was designed with the balun at the input of the tuner. This antenna tuner is designed to handle full legal power from 160 to 10 meters, matching a wide range of either balanced or unbalanced impedances. The network configuration is a high-pass T-network, with two series variable capacitors and a variable shunt inductor. See [Fig 16](#) for the schematic of the tuner. Note that the schematic is drawn in a somewhat unusual fashion. This is done to emphasize that the common connection of the series input and output capacitors and the shunt inductor is actually the subchassis used to mount these components away from the tuner's cabinet. The subchassis is insulated from the main cabinet using four heavy-duty 2-inch steatite cones.

While a T-network type of tuner can be very lossy if care isn't taken, it is very flexible in the range of impedances it can match. Special attention has been paid to minimize power loss in this tuner—particularly for low-impedance loads on the lower-frequency amateur bands. Preventing arcing or excessive power dissipation for low-impedance loads on 160 meters represents the most challenging conditions for an antenna tuner designer. To see the computed range of impedances it can handle, look over the tables in the ASCII file called TUNER.SUM on the CD-ROM in the back of this book. The tables were created using the program AAT, described previously in this chapter.

For example, assume that the load at 1.8 MHz is 12.5 + j0  $\Omega$ . For this example, the output capacitor C3 is set

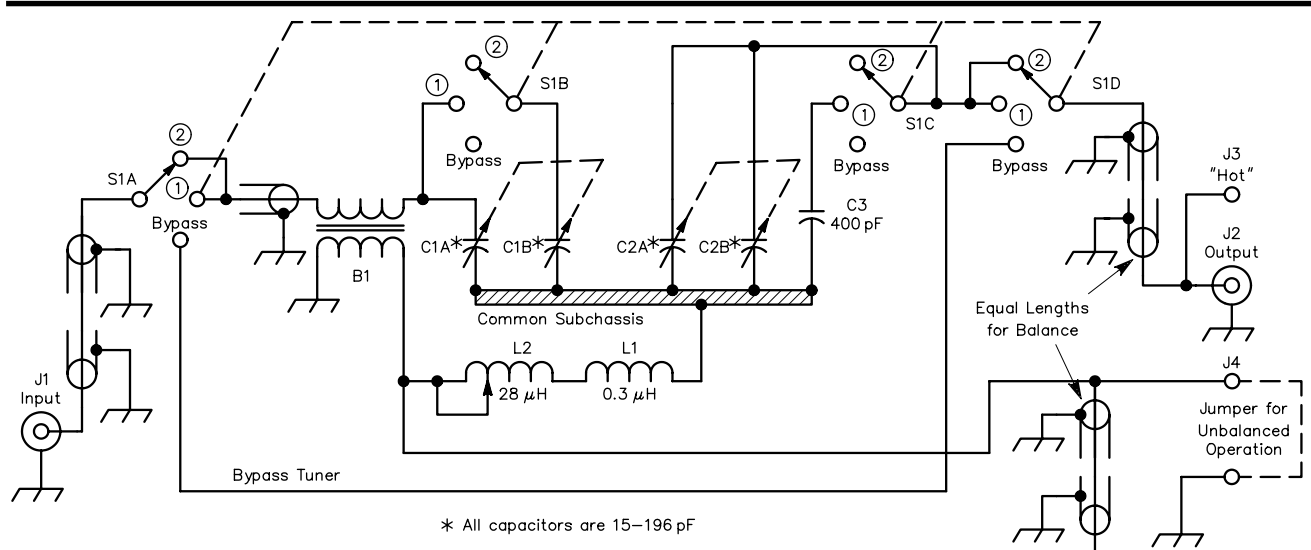
by the program to 750 pF. This dictates the values for the other two components. At 1.8 MHz, for typical values of component unloaded Q (200 for the coil), 7.9% of the power delivered to the input of the network is lost as heat. For 1500 W at the input, the loss in the network is thus 119 W. Of this, 98 W ends up in the inductor, which must be able to handle this without melting or detuning. The T-network must be used judiciously, lest it burn itself up or arc over internally.

One of the techniques used to minimize power lost in this tuner is the use of a relatively large output capacitor. (The output variable capacitor has a maximum capacitance of approximately 400 pF, including an estimated 20 pF of stray capacitance.) An additional 400 pF of fixed capacitor can be switched across the output variable capacitor on 80 or 160 meters. At 750 pF output capacitance at 1.8 MHz and a 12.5- $\Omega$  load, enough heat is generated at 1500 W input to make the inductor uncomfortably warm to the touch after 30 seconds of full-power key-down operation, but not enough to destroy the roller inductor.

For a variable capacitor used in a T-network tuner, there is a trade-off between the range of minimum to maximum capacitance and the voltage rating. This tuner uses two identical Cardwell-Johnson dual-section 154-507-1 air-variable capacitors, rated at 3000 V. Each section of the capacitor ranges from 15 to 196 pF, with an estimated 10 pF of stray capacitance associated with each section. Both sections are wired in parallel for the output capacitor, while they are switched in or out using switch S1B for the input capacitor. This strategy allows the minimum capacitance of the input capacitor to be smaller to match high-impedance loads at the higher frequencies.

The roller inductor is a high-quality Cardwell 229-203-1 unit, with a steatite body to enable it to dissipate heat without damage. The roller inductor is augmented with a series 0.3  $\mu$ H coil made of four turns of 1/4-inch copper tubing formed on a 1-inch OD form (which is then removed). This fixed coil can dissipate more heat when low values of inductance are needed for low-impedance loads at high frequencies. Both variable capacitors and the roller inductor use ceramic-insulated shaft couplers, since all components are hot electrically. Each shaft goes through a grounded bushing at the front panel to make sure none of the knobs is hot for the operator.

The balun allowing operation with balanced loads is placed at the input of this antenna coupler, rather than at the output where it is commonly placed in other designs. Putting the balun at the input stresses the balun less, since it is operating into its design resistance of 50  $\Omega$ , once the network is tuned. For unbalanced (coax) operation, the common point at the bottom of the roller inductor is grounded using a jumper at the feedthrough insulator at the rear of the cabinet. In the prototype antenna tuner, the balun was wound using 12 turns of #10 formvar insulated wire, wound side-by-side in bifilar fashion on a 2.4-inch OD core of type 43 material. After 60 seconds of key-down operation at



**Fig 16—Schematic diagram of the ARRL Antenna Tuner.**

**C1, C2**—15-196 pF transmitting variable with voltage rating of 3000 V peak, such as the E. F. Johnson 154-507-1.  
**C3**—Home-made 400 pF capacitor; more than 10 kV voltage breakdown. Made from plate glass from a “5 × 7-inch” picture frame, sandwiched in between a 4 × 6-inch, 0.030-inch thick aluminum plate and the electrically floating subchassis that also forms the

common connection between C1, C2 and L1.  
**L1**—Fixed inductor, approximately 0.3 μH, 4 turns of 1/4-inch copper tubing formed on 1-inch OD tubing.  
**L2**—Rotary inductor, 28 μH inductance, Cardwell E. F. Johnson 229-203, with steatite coil form.  
**B1**—Balun, 12 turns bifilar wound #10 Formvar wire side-by-side on 2.4-inch OD Type 43 core, Amidon FT240-43.

1500 W on 29.7 MHz, the wire becomes warm to the touch, although the core itself remains cool. We estimated that 25 W was being dissipated in the balun. Alternatively, if you don’t intend to use the tuner for balanced lines, you can delete the balun altogether.

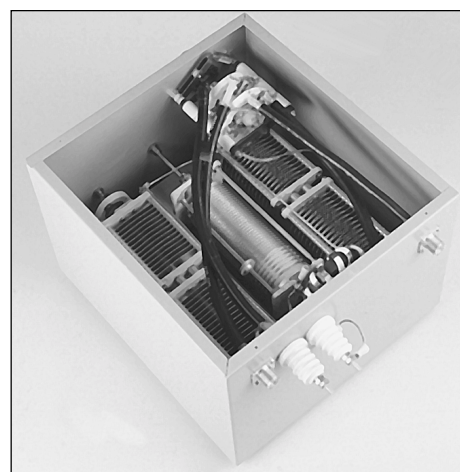
In our unit, a piece of RG-213 coax is used to connect the output coaxial socket (in parallel with the “hot” insulated feedthrough insulator) to S1D common. This adds approximately 15 pF fixed capacity to ground. An equal length of RG-213 is used at the “cold” feedthrough insulator so that the circuit remains balanced to ground when used with balanced transmission lines. When the cold terminal is jumpered to ground for unbalanced loads (that is, using the coax connector), the extra length of RG-213 is shorted out and is thus out of the circuit.

### CONSTRUCTION

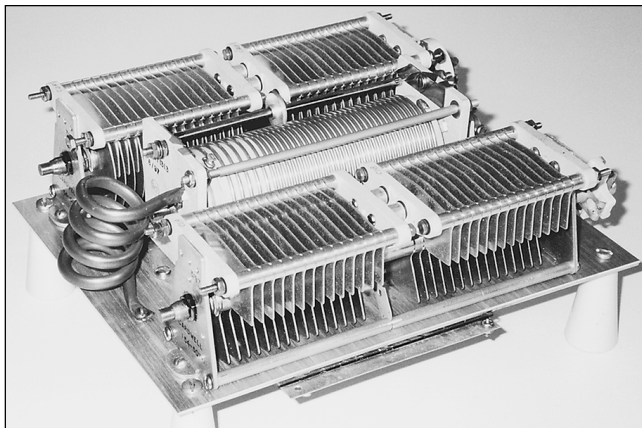
The prototype antenna tuner was mounted in a Hammond model 14151 heavy-duty, painted steel cabinet. This is an exceptionally well-constructed cabinet that does not flex or jump around on the operating table when the roller inductor shaft is rotated vigorously. The electrical components inside were spaced well away from the steel cabinet to keep losses down, especially in the variable inductor. There is also lots of clearance between components and the chassis itself to prevent arcing and stray capacity to ground. See **Figs 17** and **18** showing the layout inside the cabinet of the prototype tuner. **Fig 19** shows a view of the

front panel. The turns-counter dial for the roller inductor was bought from Surplus Sales of Nebraska.

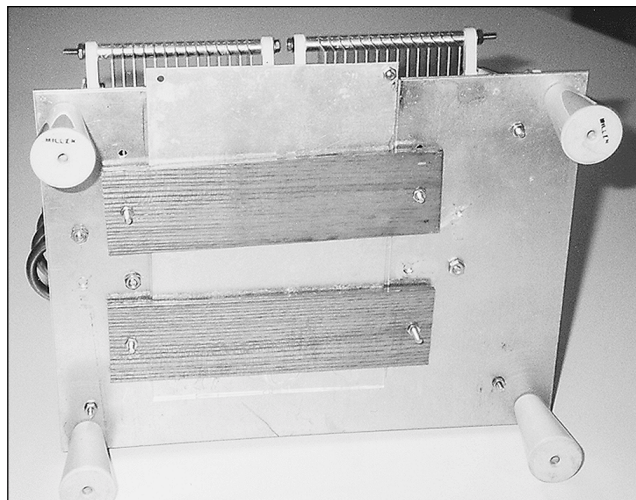
The 400-pF fixed capacitor is constructed using low-cost plate glass from a 5 × 7-inch picture frame, together



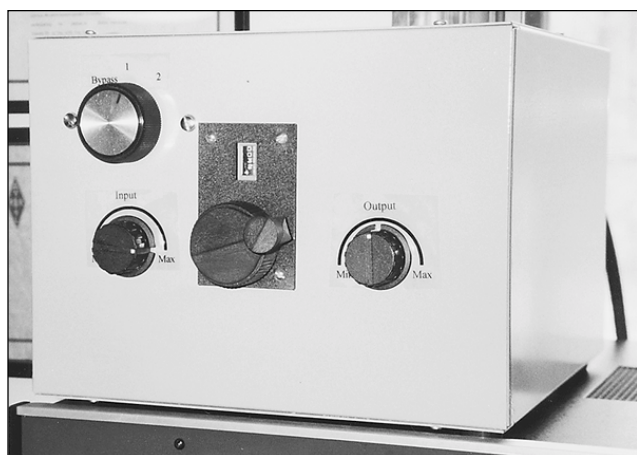
**Fig 17—Interior view of the ARRL Antenna Tuner. The balun is mounted near the input coaxial connector. The two feedthrough insulators for balanced-line operation are located near the output coaxial unbalanced connector. The Radioswitch Corporation high-voltage switch is mounted to the front panel. Ceramic-insulated shaft couplers through ground 1/4-inch panel bushings couple the variable components to the knobs.**



**Fig 18—Bottom view of the subchassis, showing the four white insulators used to isolate the subchassis from the cabinet. The homemade 400-pF fixed capacitor C3 is epoxied to the bottom of the subchassis, sandwiching a piece of plate glass as the dielectric between the subchassis and a flat piece of aluminum.**



**Fig 20—Bottom view of subchassis, showing the two strips of wood ensuring mechanical stability of the C3 capacitor assembly.**



**Fig 19—Front panel view of the ARRL Antenna Tuner. The high-quality turns counter dial is from Surplus Sales of Nebraska.**

with an approximately 4 × 6-inch flat piece of sheet aluminum that is 0.030-inch thick. The tuner's 10½ × 8-inch subchassis forms the other plate of this homebrew capacitor. For mechanical rigidity, the subchassis uses two ¼-inch thick aluminum plates. The ¼-inch thick glass is epoxied to the bottom of the subchassis. The 4 × 6-inch aluminum sheet forming the second plate of the 400-pF fixed capacitor is in turn epoxied to the glass to make a stable, high-voltage, high-current fixed capacitor. Two strips of wood are screwed down over the assembly underneath the subchassis to make sure the capacitor stays in place. The estimated breakdown voltage is 12,000 V. See **Fig 20** for a bottom view of the subchassis.

Note: The dielectric constant of the glass in a cheap (\$2 at Wal-Mart) picture frame varies. The final dimensions of the aluminum sheet secured with one-hour epoxy to the glass was varied by sliding it in and out until 400 pF was

reached, while the epoxy was still wet, using an Autek RF-1 as a capacitance meter. Don't let epoxy slop over the edges—this can arc and burn permanently!

S1 is bolted directly to the front of the cabinet. S1 is a special high-voltage RF switch from Radio Switch Corporation, with four poles and three positions. It is not inexpensive, but we wanted to have no weak points in the prototype unit. A more frugal ham might want to substitute two more common surplus DPDT switches for S1. One would bypass the tuner when the operator desires to do that. The other would switch the additional 400-pF fixed capacitor across variable C3 and also parallel both sections of C1 together for the lower frequencies. Both switches would have to be capable of handling high RF voltages, of course.

## OPERATION

The ARRL Antenna Tuner is designed to handle the output from transmitters that operate up to 1.5 kW. An external SWR indicator is used between the transmitter and the antenna tuner to show when a matched condition is attained. Most often the SWR meter built into the transceiver is used to tune the tuner and then the amplifier is switched on. The builder may want to integrate an SWR meter in the tuner circuit between J1 and the arm of S1A.

Never *hot switch* an antenna tuner, as this can damage both transmitter and tuner. For initial setting below 10 MHz, set S1 to position 2 and C1 at midrange, C2 at full mesh. With a few watts of RF, adjust the roller inductor for a decrease in reflected power. Then adjust C1 and L2 alternately for the lowest possible SWR, also adjusting C2 if necessary. If a satisfactory SWR cannot be achieved, try S1 at position 3 and repeat the steps above. Finally, increase the transmitter power to maximum and touch up the tuner's controls if necessary. When tuning, keep your transmissions brief and identify your station.

For operation above 10 MHz, again initially use S1 set

to position 2, and if SWR cannot be lowered properly, try S1 set to position 3. This will probably be necessary for 24 or 28-MHz operation. In general, you want to set C2 for as much capacitance as possible, especially on the lower frequencies. This will result in the least amount of loss through the antenna tuner. The first position of S1 permits switched-through operation direct to the antenna when the antenna tuner is not needed.

### FURTHER COMMENTS ABOUT THE ARRL ANTENNA TUNER

Surplus coils and capacitors are suitable for use in this circuit. L2 should have at least 25  $\mu\text{H}$  of inductance and be constructed with a steatite body. There are roller inductors on the market made with Delrin plastic bodies but these are very prone to melting under stress and should be avoided. The tuning capacitors need to have 200 pF or more of capacitance per section at a breakdown voltage of at least 3000 V. You could save some money by using a single-section variable capacitor for the output capacitor, rather than the dual-section unit we used. It should have a maximum capacitance of 400 pF and a voltage rating of 3000 V.

Measured insertion loss for this antenna tuner is low. The worst-case load tested was four 50- $\Omega$  dummy loads in parallel to make a 12.5- $\Omega$  load at 1.8 MHz. Running 1500 W keydown for 30 seconds heated the variable inductor enough so that you wouldn't want to keep your hand on it for long. None of the other components became hot in this test.

At higher frequencies (and into a 50- $\Omega$  load at 1.8 MHz), the roller inductor was only warm to the touch at

1500 W keydown for 30 seconds. The #10 balun wire, as mentioned previously, was the warmest component in the antenna tuner for frequencies above 14 MHz, although it was far from catastrophic.

### BIBLIOGRAPHY

Source material and more extended discussion of topics covered in this chapter can be found in the references given below and in the textbooks listed at the end of [Chapter 2](#).

- D. K. Belcher, "RF Matching Techniques, Design and Example," *QST*, Oct 1972, p 24.
- W. Bruene, "Introducing the Series-Parallel Network," *QST*.
- T. Dorbuck, "Matching-Network Design," *QST*, Mar 1979, p 26.
- G. Grammer, "Simplified Design of Impedance-Matching Networks," in three parts, *QST*.
- M. W. Maxwell, "Another Look at Reflections," *QST*, Apr, Jun, Aug, and Oct 1973; Apr and Dec 1974, and Aug 1976.
- B. Pattison, "A Graphical Look at the L Network," *QST*.  
"QST Compares: Four High-Power Antenna Tuners," *QST*, Mar 1997, pp 73-77.
- E. Wingfield, "New and Improved Formulas for the Design of Pi and Pi-L Networks," *QST*, Aug 1983, p 23.
- F. Witt, "How to Evaluate Your Antenna Tuner—Parts 1 and 2," *QST*, April and May 1995, pp 30-34 and pp 33-37 respectively.
- F. Witt, "Baluns in the Real (and Complex) World," *The ARRL Antenna Compendium Vol 5* (Newington, ARRL: 1996), pp 171-181.

# Coupling the Line to the Antenna

Chapter 25 looked at system design from the point of view of the transmitter, examining what could be done to ensure that the transmitter works into  $50\ \Omega$ , its design load. In many systems it was desirable—or necessary—to place an antenna tuner between the transmitter and the transmission line going to the antenna. This is particularly true for a single-

wire antenna used on multiple amateur bands.

In this chapter, we will look at system design from the point of view of the transmission line. We will examine what should be done to ensure that the transmission line operates at best efficiency, once a particular antenna is chosen to do a particular job.

## Choosing a Transmission Line

Until you get into the microwave region, where waveguides become practical, there are only two practical choices for transmission lines: coaxial cable (usually called *coax*) and parallel-conductor lines (often called *open-wire* lines).

The shielding of coaxial cable offers advantages in incidental radiation and routing flexibility. Coax can be tied or taped to the legs of a metal tower without problem, for example. Some varieties of coax can even be buried underground. Coaxial cable can perform acceptably even with significant SWR. (Refer to information in Chapter 24.) A 100-foot length of RG-8 coax has 1.1 dB matched-line loss at 30 MHz. If this line were used with a load of  $250 + j\ 0\ \Omega$  (an SWR of 5:1), the total line loss would be 2.2 dB. This represents about a half S unit on most receivers.

On the other hand, open-wire line has the advantage of both lower loss and lower cost compared to coax. 600- $\Omega$  open-wire line at 30 MHz has a matched loss of only 0.1 dB. If you use such open-wire line with the same 5:1 SWR, the total loss would about 0.3 dB. In fact, even if the SWR rose to 20:1, the total loss would be less than 1 dB. Typical open-wire line sells for about  $\frac{1}{3}$  the cost of good quality coax cable.

Open-wire line is enjoying a renaissance of sorts with amateurs wishing to cover multiple HF bands with a single-wire antenna. This is particularly true since the bands at 30, 17 and 12 meters became available in the early 1980s. The 102-foot long *G5RV dipole*, fed with open-wire ladder line into an antenna tuner, has become popular as a simple all-band antenna. The simple 135-foot long flat-top dipole, fed with open-wire 450- $\Omega$  *window* ladder-line, is also very popular among all-band enthusiasts.

Despite their inherently low-loss characteristics, open-wire lines are not often employed above about 100 MHz. This is because the physical spacing between the two wires begins to become an appreciable fraction of a wavelength, leading to undesirable radiation by the line itself. Some form of coaxial cable is almost universally used in the VHF and UHF amateur bands.

So, apart from concerns about convenience and the matter of cost, how do you go about choosing a transmission line for a particular antenna? Let's start with some simple cases.

### FEEDING A SINGLE-BAND ANTENNA

If the system is for a single frequency band, and if the impedance of the antenna doesn't vary too radically over the frequency band, then the choice of transmission line is easy. Most amateurs would opt for convenience—they would use coaxial cable to feed the antenna, usually without an antenna tuner.

An example of such an installation is a half-wave 80-meter dipole fed with 50- $\Omega$  coax. The matched-line loss for 100 feet of 50- $\Omega$  RG-8 coax at 3.5 MHz is only 0.33 dB. At each end of the 80-meter band, this dipole will exhibit an SWR of about 6:1. The additional loss caused by this level of SWR at this frequency is less than 0.6 dB, for a total line loss of 0.9 dB. Since 1 dB represents an almost undetectable change in signal strength at the receiving end, it does not matter whether the line is flat or not for this 80-meter system.

This is true provided that the transmitter can operate properly into the load presented to it by the impedance at the input of the transmission line. An antenna tuner is sometimes used as a *line flattener* to ensure that the



transmitter operates into its design load impedance. On the other amateur bands, where the percentage bandwidth is smaller than that on 75/80 meters, a simple dipole fed with coax will provide an acceptable SWR for most transmitters—without an antenna tuner.

If you want a better match at the antenna feed point of a single-band antenna to coax, you can provide some sort of matching network at the antenna. We'll look further into schemes for achieving matched antenna systems later in this chapter, when we'll examine single-band beta, gamma and omega matches.

## FEEDING A MULTIBAND RESONANT ANTENNA

A *multiband resonant antenna* is one where special measures are used to make a single antenna act as though it were resonant on each of several amateur bands. Often, *trap* circuits are employed. (Information on traps is given in [Chapter 7](#).) For example, a trap dipole is equivalent to a resonant  $\lambda/2$  dipole on each of the bands for which it is designed.

Another common multiband resonant antenna is one where several dipoles cut for different frequencies are paralleled together at a common feed point and fed with a single coax cable. This arrangement acts as though it had an independent, resonant  $\lambda/2$  dipole on each frequency band. (There is some interaction between the individual wires, which should be separated physically as far as practical to reduce mutual coupling.)

Another type of multiband resonant antenna is a *log-periodic dipole array* (LPDA), although this can hardly be called a simple amateur antenna. The log periodic features moderate gain and pattern, with a low SWR across a fairly wide band of frequencies. See [Chapter 10](#) for more details.

Yet another popular multiband resonant antenna is the trapped *triband* Yagi, or a multiband interlaced quad. On the amateur HF bands, the triband Yagi is almost as popular as the simple  $\lambda/2$  dipole. See [Chapter 11](#) for more information on Yagis.

A multiband resonant antenna doesn't present much of a design challenge—you simply feed it with coax that has characteristic impedance close to the antenna's feed-point impedance. Usually, 50- $\Omega$  cable, such as RG-8, is used.

## FEEDING A MULTIBAND NON-RESONANT ANTENNA

Let's say that you wish to use a single antenna, such as a 100-foot long dipole, on multiple amateur bands. You know from [Chapter 2](#) that since the physical length of the antenna is fixed, the feed-point impedance of the antenna will vary on each band. In other words, except by chance, the antenna will *not* be resonant—or even close to resonant—on multiple bands.

For multiband non-resonant antenna systems, the most appropriate transmission line is often an open-wire, parallel-conductor line, because of the inherently low matched-line loss characteristic of these types of lines. Such a system is

called an *unmatched* system, because no attempt is made to match the impedance at the antenna's feed point to the  $Z_0$  of the transmission line. Commercial 450- $\Omega$  window ladder line has become popular for this kind of application. It is almost as good as traditional homemade open-wire line for most amateur systems.

The transmission line will be mismatched most of the time, and on some frequencies it will be severely mismatched. Because of the mismatch, the SWR on the line will vary widely with frequency. As shown in [Chapter 24](#), such a variation in load impedance has an impact on the loss suffered in the feed line. Let's look at the losses suffered in a typical multiband non-resonant system.

**Table 1** summarizes the feed-point information over the HF amateur bands for a 100-foot long dipole, mounted as a flat-top, 50 feet high over typical earth. In addition, Table 1 shows the total line loss and the SWR at the antenna feed point. As usual, there is nothing particularly significant about the choice of a 100-foot long antenna. Neither is there anything significant about a 100-foot long transmission line from that antenna to the operating position. Both are practical lengths that could very well be encountered in a real-world situation. At 1.8 MHz, the loss in the transmission line is large—8.9 dB. This is due to the fact that the SWR at the feed point is a very high 793:1, a direct result of the fact that the antenna is extremely short in terms of wavelength.

**Table 2** summarizes the same information as in Table 1, but this time for a 66-foot long inverted-V dipole, whose apex is 50 feet over typical earth and whose included angle between its two legs is 120°. The situation at 1.83 MHz is even worse, as might be expected because this antenna is even shorter electrically than its 100-foot flat-top cousin. The line loss has risen to 15.1 dB!

Under such severe mismatches, another problem can arise. Transmission lines with solid dielectric have voltage and current limitations. At lower frequencies with electrically short antennas, this can be a more compelling limitation than the amount of power loss. The ability of a line to handle RF power is inversely proportional to the SWR. For example, a

**Table 1**  
Impedance of Center-Fed 100' Flat-top Dipole,  
50' High Over Average Ground

Frequency MHz	Antenna Feed-Point Impedance, $\Omega$	Loss for 100' 450- $\Omega$ Line, dB	SWR
1.83	4.5 - j 1673	8.9	792.9
3.8	39 - j 362	0.5	18.3
7.1	481 + j 964	0.2	6.7
10.1	2584 - j 3292	0.6	16.8
14.1	85 - j 123	0.3	5.2
18.1	2097 + j 1552	0.4	8.1
21.1	345 - j 1073	0.6	10.1
24.9	202 + j 367	0.3	3.9
28.4	2493 - j 1375	0.6	8.1

**Table 2**  
**Impedance of Center-Fed 66' Inv-V Dipole,**  
**50' Apex Over Average Ground**

Frequency MHz	Antenna Feed-Point Impedance, $\Omega$	Loss for 100' 450- $\Omega$ Line, dB	SWR
1.83	$1.6 - j 2257$	15.1	1627.7
3.8	$10 - j 879$	3.9	195.9
7.1	$65 - j 41$	0.2	6.3
10.1	$22 + j 648$	1.9	68.3
14.1	$5287 - j 1310$	0.6	13.9
18.1	$198 - j 820$	0.6	10.8
21.1	$103 - j 181$	0.3	4.8
24.9	$269 + j 570$	0.3	4.9
28.4	$3089 + j 774$	0.6	8.1

line rated for 1.5 kW when matched, should be operated at only 150 W when the SWR is 10:1.

At the mismatch on 1.83 MHz illustrated for the 66-foot inverted-V dipole in Table 2, the line may well arc over or burn up due to the extremely high level of SWR (at 1627.7:1).

450- $\Omega$  window-type ladder line using two #16 conductors should be safe up to the 1500 W level for frequencies where the antenna is nearly a half-wavelength long. For the 100-foot dipole, this would be above 3.8 MHz, and for the 66-foot long dipole, this would be above 7 MHz. For the very short antennas illustrated above, however, even 450- $\Omega$  window line may not be able to take full amateur legal power.

## Matched Lines

The rest of this chapter will deal with systems where the feed-point impedance of the antenna is manipulated to match the  $Z_0$  of the transmission line feeding the system. Since operating a transmission line at a low SWR requires that the line be terminated in a load matching the line's characteristic impedance, the problem can be approached from two standpoints:

- (1) selecting a transmission line having a characteristic impedance that matches the antenna impedance at the point of connection, or
- (2) transforming the antenna resistance to a value that matches the  $Z_0$  of the line selected.

The first approach is simple and direct, but its application is obviously limited—the antenna impedance and the line impedance are alike only in a few special cases. Commercial transmission lines come in a limited variety of characteristic impedances. Antenna feed-point impedances vary all over the place.

The second approach provides a good deal of freedom in that the antenna and line can be selected independently. The disadvantage of the second approach is that it is more complicated in terms of actually constructing the matching system at the antenna. Further, this approach sometimes calls for a tedious routine of measurement and adjustment before the desired match is achieved.

### Operating Considerations

Most antenna systems show a marked change in impedance when the frequency is changed greatly. For this reason it is usually possible to match the line impedance only on one frequency. A matched antenna system is consequently a one-band affair, in most cases. It can, however, usually be operated over a fair frequency range within a given band.

The frequency range over which the SWR is low is determined by how rapidly the impedance changes as the frequency is changed. If the change in impedance is small

for a given change in frequency, the SWR will be low over a fairly wide band of frequencies. However, if the impedance change is rapid (implying a sharply resonant or high-Q antenna), the SWR will also rise rapidly as the operating frequency is shifted away from antenna resonance, where the line is matched. See the discussion of Q in [Chapter 2](#).

### Antenna Resonance

In general, achieving a good match to a transmission line means that the antenna is resonant. (Some types of long-wire antennas, such as rhombics, are exceptions. Their input impedances are resistive over a wide band of frequencies, making such systems essentially non-resonant.)

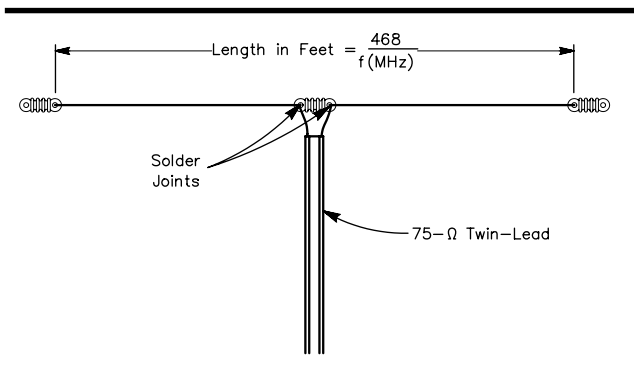
The higher the Q of an antenna system, the more essential it is that resonance be established before an attempt is made to match the line. This is particularly true of close-spaced parasitic arrays. With simple dipole antennas, the tuning is not so critical, and it is usually sufficient to cut the antenna to the length given by the appropriate equation. The frequency should be selected to be at the center of the range of frequencies (which may be the entire width of an amateur band) over which the antenna is to be used.

## DIRECT MATCHING TO THE ANTENNA

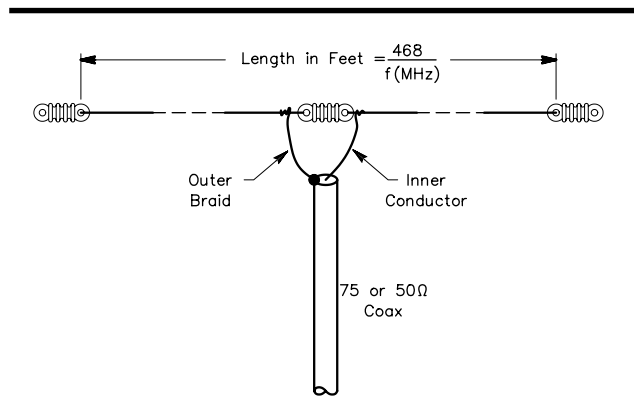
### Open-Wire Line

As discussed previously, the impedance at the center of a resonant  $\lambda/2$  antenna at heights of the order of  $\lambda/4$  and more is resistive and is in the neighborhood of 50 to 70  $\Omega$ . This is well matched by open-wire line with a characteristic impedance of 75  $\Omega$ . However, transmitting 75- $\Omega$  twin-lead is becoming increasingly difficult to find in the US, although it is apparently more commonly available in the UK.

A typical direct-matching system is shown in [Fig 1](#). No precautions are necessary beyond keeping the line dressed away from the feed point symmetrically with respect to the antenna. This system is designed for single-band operation, although it can be operated at *odd* multiples of



**Fig 1—A  $\lambda/2$  dipole fed directly with 75- $\Omega$  twin-lead, giving a close match between antenna and feed-line impedance. The leads in the “Y” from the end of the line to the ends of the center insulator should be as short as possible.**



**Fig 2—A  $\lambda/2$ - $\lambda$  antenna fed with 75- $\Omega$  coaxial cable. The outside of the outer conductor of the line may be grounded for lightning protection.**

the fundamental. For example, an antenna that is resonant near the low-frequency end of the 7-MHz band will operate with a relatively low SWR across the 21-MHz band.

At the fundamental frequency, the SWR should not exceed about 2:1 within a frequency range  $\pm 2\%$  from the frequency of exact resonance. Such a variation corresponds approximately to the entire width of the 7-MHz band, if the antenna is resonant at the center of the band. A wire antenna is assumed. Antennas having a greater ratio of diameter to length will have a lower change in SWR with frequency.

### Coaxial Cable

Instead of using twin-lead as just described, the center of a  $\lambda/2$  dipole may be fed through 75- $\Omega$  coaxial cable such as RG-11, as shown in **Fig 2**. Cable having a characteristic impedance of 50  $\Omega$ , such as RG-8, may also be used. RG-8 may actually be preferable, because at the heights many amateurs install their antennas, the feed-point impedance is closer to 50  $\Omega$  than it is to 75  $\Omega$ . The principle of operation is exactly the same as with twin-lead, and the same remarks about SWR apply. However, there is a considerable practical difference between the two types of line. With the parallel-conductor line the system is symmetrical, but with coaxial line it is inherently *unbalanced*.

Stated broadly, the unbalance with coaxial line is caused by the fact that the outside surface of the outer braid is not coupled to the antenna in the same way as the inner conductor and the inner surface of the outer braid. The overall result is that current will flow on the outside of the outer conductor in the simple arrangement shown in Fig 2. The unbalance is small if the line diameter is very small compared with the length of the antenna, a condition that is met fairly well at the lower amateur frequencies. It is not negligible in the VHF and UHF range, however, nor should it be ignored at 28 MHz. The system must be detuned for currents on the outside of the line. See the section on Baluns later in this chapter for more details about balanced loads used with unbalanced transmission lines.

## MATCHING DEVICES AT THE ANTENNA

### Quarter-Wave Transformers

The impedance-transforming properties of a  $\lambda/4$  transmission line can be used to good advantage for matching the feed-point impedance of an antenna to the characteristic impedance of the line. As described in [Chapter 24](#), the input impedance of a  $\lambda/4$  line terminated in a resistive impedance  $Z_R$  is

$$Z_i = \frac{Z_0^2}{Z_L} \quad (\text{Eq 1})$$

where

$Z_i$  = the impedance at the input end of the line

$Z_0$  = the characteristic impedance of the line

$Z_L$  = the impedance at the load end of the line

Rearranging this equation gives

$$Z_0 = \sqrt{Z_i Z_L} \quad (\text{Eq 2})$$

This means that any value of load impedance  $Z_L$  can be transformed into any desired value of impedance  $Z_i$  at the input terminals of a  $\lambda/4$  line, provided the line can be constructed to have a characteristic impedance  $Z_0$  equal to the square root of the product of the other two impedances. The factor that limits the range of impedances that can be matched by this method is the range of values for  $Z_0$  that is physically realizable. The latter range is approximately 50 to 600  $\Omega$ . Practically any type of line can be used for the matching section, including both air-insulated and solid-dielectric lines.

The  $\lambda/4$  transformer may be adjusted to resonance before being connected to the antenna by short-circuiting one end and coupling that end inductively to a dip meter. The length of the short-circuiting conductor lowers the frequency slightly, but this can be compensated for by adding half the length of the shorting bar to each conductor after resonating, measuring the shorting-bar length between the centers of the conductors.

## Yagi Driven Elements

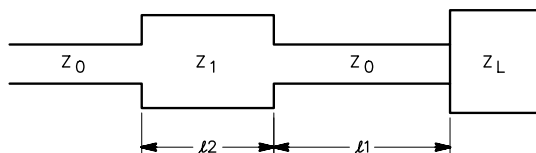
Another application for the  $\lambda/4$  linear transformer is in matching the low antenna impedance encountered in close-spaced, monoband Yagi arrays to a 50- $\Omega$  transmission line. The impedances at the antenna feed point for typical Yagis range from about 8 to 30  $\Omega$ . Let's assume that the feed-point impedance is 25  $\Omega$ . A matching section having  $Z_0 = \sqrt{50 \times 25} = 35.4 \Omega$  is needed. Since there is no commercially available cable with a  $Z_0$  of 35.4  $\Omega$ , a pair of  $\lambda/4$ -long 75- $\Omega$  RG-11 coax cables connected in parallel will have a net  $Z_0$  of  $75/2 = 37.5 \Omega$ , close enough for practical purposes.

## Series-Section Transformers

The series-section transformer has advantages over either stub tuning or the  $\lambda/4$  transformer. Illustrated in **Fig 3**, the series-section transformer bears considerable resemblance to the  $\lambda/4$  transformer. (Actually, the  $\lambda/4$  transformer is a special case of the series-section transformer.) The important differences are (1) that the matching section need not be located exactly at the load, (2) the matching section may be less than a quarter wavelength long, and (3) there is great freedom in the choice of the characteristic impedance of the matching section.

In fact, the matching section can have any characteristic impedance that is not too close to that of the main line. Because of this freedom, it is almost always possible to find a length of commercially available line that will be suitable as a matching section. As an example, consider a 75- $\Omega$  line, a 300- $\Omega$  matching section, and a pure-resistance load. It can be shown that a series-section transformer of 300- $\Omega$  line may be used to match any resistance between 5  $\Omega$  and 1200  $\Omega$  to the main line.

Frank Regier, OD5CG, described series-section transformers in Jul 1978 *QST*. This information is based on that article. The design of a series-section transformer consists of determining the length  $\ell_2$  of the series or matching section and the distance  $\ell_1$  from the load to the point where the section should be inserted into the main line. Three quantities must be known. These are the characteristic impedances of the main line and of the matching section, both assumed purely resistive, and the complex-load impedance. Either of two design methods may be used. One is a graphic method using the Smith Chart, and the other is algebraic. You can take your choice. (Of course the algebraic method may be adapted to



**Fig 3—Series section transformer  $Z_1$  for matching transmission-line  $Z_0$  to load,  $Z_L$ .**

obtaining a computer solution.) The Smith Chart graphic method is described in [Chapter 28](#).

## Algebraic Design Method

The two lengths  $\ell_1$  and  $\ell_2$  are to be determined from the characteristic impedances of the main line and the matching section,  $Z_0$  and  $Z_1$ , respectively, and the load impedance  $Z_L = R_L + j X_L$ . The first step is to determine the normalized impedances.

$$n = \frac{Z_1}{Z_0} \quad (\text{Eq 3})$$

$$r = \frac{R_L}{Z_0} \quad (\text{Eq 4})$$

$$x = \frac{X_L}{Z_0} \quad (\text{Eq 5})$$

Next,  $\ell_2$  and  $\ell_1$  are determined from

$\ell_2 = \arctan B$  where

$$B = \pm \sqrt{\frac{(r-1)^2 + x^2}{r\left(n - \frac{1}{n}\right)^2 - (r-1)^2 - x^2}} \quad (\text{Eq 6})$$

$\ell_1 = \arctan A$  where

$$A = \frac{\left(n - \frac{r}{n}\right)B + x}{r + xnB - 1} \quad (\text{Eq 7})$$

Lengths  $\ell_2$  and  $\ell_1$  as thus determined are electrical lengths in degrees (or radians). The electrical lengths in wavelengths are obtained by dividing by  $360^\circ$  (or by  $2\pi$  radians). The physical lengths (main line or matching section, as the case may be), are then determined from multiplying by the free-space wavelength and by the velocity factor of the line.

The sign of  $B$  may be chosen either positive or negative, but the positive sign is preferred because it results in a shorter matching section. The sign of  $A$  may not be chosen but can turn out to be either positive or negative. If a negative sign occurs and a computer or electronic calculator is then used to determine  $\ell_1$ , a negative electric length will result for  $\ell_1$ . If this happens, add  $180^\circ$ . The resultant electrical length will be correct both physically and mathematically.

In calculating  $B$ , if the quantity under the radical is negative, an imaginary value for  $B$  results. This would mean that  $Z_1$ , the impedance of the matching section, is too close to  $Z_0$  and should be changed.

Limits on the characteristic impedance of  $Z_1$  may be calculated in terms of the SWR produced by the load on the main line without matching. For matching to occur,  $Z_1$  should either be greater than  $Z_0 \sqrt{\text{SWR}}$  or less than  $Z_0 / \sqrt{\text{SWR}}$ .

### An Example

As an example, suppose we want to feed a 29-MHz ground-plane vertical antenna with RG-58 type foam-dielectric coax. We'll assume the antenna impedance to be  $36\ \Omega$ , pure resistance, and use a length of RG-59 foam-dielectric coax as the series section. See **Fig 4**.

$Z_0$  is  $50\ \Omega$ ,  $Z_1$  is  $75\ \Omega$ , and both cables have a velocity factor of 0.79. Because the load is a pure resistance we may determine the SWR to be  $50/36 = 1.389$ . From the above,  $Z_1$  must have an impedance greater than  $50\sqrt{1.389} = 58.9\ \Omega$ . From the earlier equations,  $n = 75/50 = 1.50$ ,  $r = 36/50 = 0.720$ , and  $x = 0$ .

Further,  $B = 0.431$  (positive sign chosen), and  $\ell_2 = 23.3^\circ$  or  $0.065\ \lambda$ . The value of  $A$  is  $-1.570$ . Calculating  $\ell_1$  yields  $-57.5^\circ$ . Adding  $180^\circ$  to obtain a positive result gives  $\ell_1 = 122.5^\circ$ , or  $0.340\ \lambda$ .

To find the physical lengths  $\ell_1$  and  $\ell_2$  we first find the free-space wavelength.

$$\lambda = \frac{983.6}{f(\text{MHz})} = 33.92 \text{ feet}$$

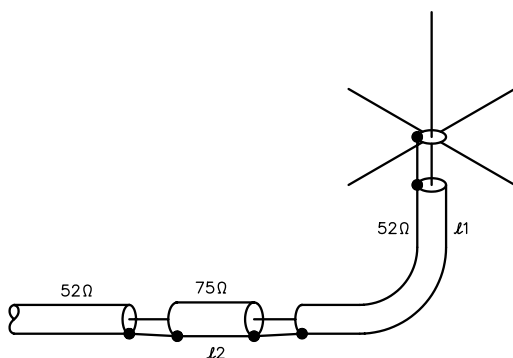
Multiply this value by 0.79 (the velocity factor for both types of line), and we obtain the electrical wavelength in coax as 26.81 feet. From this,  $\ell_1 = 0.340 \times 26.81 = 9.12$  feet, and  $\ell_2 = 0.065 \times 26.81 = 1.74$  feet.

This completes the calculations. Construction consists of cutting the main coax at a point 9.12 feet from the antenna and inserting a 1.74-foot length of the 75- $\Omega$  cable.

### The Quarter-Wave Transformer

The antenna in the preceding example could also have been matched by a  $\lambda/4$  transformer at the load. Such a transformer would use a line with a characteristic impedance of  $42.43\ \Omega$ . It is interesting to see what happens in the design of a series-section transformer if this value is chosen as the characteristic impedance of the series section.

Following the same steps as before, we find  $n = 0.849$ ,  $r = 0.720$ , and  $x = 0$ . From these values we find  $B = 8$  and



**Fig 4**—Example of series-section matching. A 36- $\Omega$  antenna is matched to 50- $\Omega$  coax by means of a length of 75- $\Omega$  cable.

$\ell_2 = 90^\circ$ . Further,  $A = 0$  and  $\ell_1 = 0^\circ$ . These results represent a  $\lambda/4$  section at the load, and indicate that, as stated earlier, the  $\lambda/4$  transformer is indeed a special case of the series-section transformer.

### Tapered Lines

A tapered line is a specially constructed transmission line in which the impedance changes gradually from one end of the line to the other. Such a line operates as a broadband impedance transformer. Because tapered lines are used almost exclusively for matching applications, they are discussed in this chapter rather than in **Chapter 24**.

The characteristic impedance of an open-wire line can be tapered by varying the spacing between the conductors, as shown in **Fig 5**. Coaxial lines can be tapered by varying the diameter of either the inner conductor or the outer conductor, or both. The construction of coaxial tapered lines is beyond the means of most amateurs, but open-wire tapered lines can be made rather easily by using spacers of varied lengths. In theory, optimum broadband impedance transformation is obtained with lines having an exponential taper, but in practice, lines with a linear taper as shown in **Fig 5** work very well.

A tapered line provides a match from high frequencies down to the frequency at which the line is approximately  $1\ \lambda$  long. At lower frequencies, especially when the tapered line length is  $\lambda/2$  or less, the line acts more as an impedance lump than a transformer. Tapered lines are most useful at VHF and UHF, because the length requirement becomes unwieldy at HF.

Air-insulated open-wire lines can be designed from the equation

$$S = \frac{d \times 10^{Z_0/276}}{2} \quad (\text{Eq 8})$$

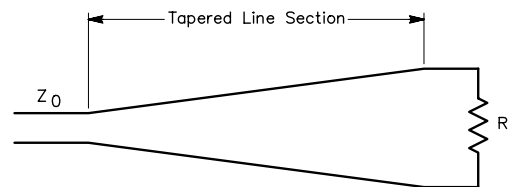
where

$S$  = center-to-center spacing between conductors

$d$  = diameter of conductors (same units as  $S$ )

$Z_0$  = characteristic impedance,  $\Omega$

For example, for a tapered line to match a 300- $\Omega$  source



**Fig 5**—A tapered line provides a broadband frequency transformation if it is one wavelength long or more. From a practical construction standpoint, the taper may be linear.

to an 800-Ω load, the spacing for the selected conductor diameter would be adjusted for a 300-Ω characteristic impedance at one end of the line, and for an 800-Ω characteristic impedance at the other end of the line. The disadvantage of using open-wire tapered lines is that characteristic impedances of 100 Ω and less are impractical.

### Multiple Quarter-Wave Sections

An approach to the smooth-impedance transformation of the tapered line is provided by using two or more  $\lambda/4$  transformer sections in series, as shown in **Fig 6**. Each section has a different characteristic impedance, selected to transform the impedance at its input to that at its output. Thus, the overall impedance transformation from source to load takes place as a series of gradual transformations. The frequency bandwidth with multiple sections is greater than for a single section. This technique is useful at the upper end of the HF range and at VHF and UHF. Here, too, the total line length that is required may become unwieldy at the lower frequencies.

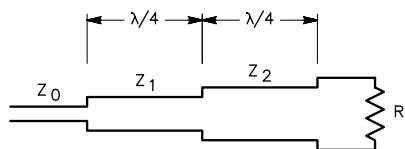
A multiple-section line may contain two or more  $\lambda/4$  transformer sections; the more sections in the line, the broader is the matching bandwidth. Coaxial transmission lines may be used to make a multiple-section line, but standard coax lines are available in only a few characteristic impedances. Open-wire lines can be constructed rather easily for a specific impedance, designed from **Eq 8** above.

The following equations may be used to calculate the intermediate characteristic impedances for a two-section line.

$$Z_1 = \sqrt[4]{RZ_0^3} \quad (\text{Eq 9})$$

$$Z_2 = \sqrt[3]{R^2 Z_1} \quad (\text{Eq 10})$$

where terms are as illustrated in **Fig 6**. For example, assume we wish to match a 75-Ω source ( $Z_0$ ) to an 800-Ω load. From **Eq 9**, calculate  $Z_1$  to be 135.5 Ω. Then from **Eq 10**, calculate  $Z_2$  to be 442.7 Ω. As a matter of interest, for this example the virtual impedance at the junction of  $Z_1$  and  $Z_2$  is 244.9 Ω. (This is the same impedance that would be required for a



**Fig 6**—Multiple quarter-wave matching sections approximate the broadband matching transformation provided by a tapered line. Two sections are shown here, but more may be used. The more sections in the line, the broader is the matching bandwidth.  $Z_0$  is the characteristic impedance of the main feed line, while  $Z_1$  and  $Z_2$  are the intermediate impedances of the matching sections. See text for design equations.

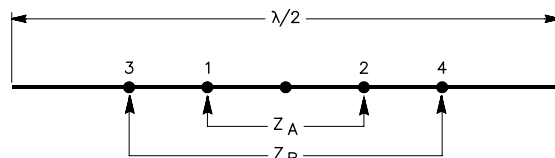
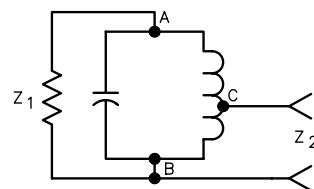
single-section  $\lambda/4$  matching section.)

### Delta Matching

Among the properties of a coil and capacitor resonant circuit is that of transforming impedances. If a resistive impedance,  $Z_1$  in **Fig 7**, is connected across the outer terminals AB of a resonant LC circuit, the impedance  $Z_2$  as viewed looking into another pair of terminals such as BC will also be resistive, but will have a different value depending on the mutual coupling between the parts of the coil associated with each pair of terminals.  $Z_2$  will be less than  $Z_1$  in the circuit shown. Of course this relationship will be reversed if  $Z_1$  is connected across terminals BC and  $Z_2$  is viewed from terminals AB.

As stated in **Chapter 2**, a resonant antenna has properties similar to those of a tuned circuit. The impedance presented between any two points symmetrically placed with respect to the center of a  $\lambda/2$  antenna will depend on the distance between the points. The greater the separation, the higher the value of impedance, up to the limiting value that exists between the open ends of the antenna. This is also suggested in **Fig 7**, in the lower drawing. The impedance  $Z_A$  between terminals 1 and 2 is lower than the impedance  $Z_B$  between terminals 3 and 4. Both impedances, however, are purely resistive if the antenna is resonant.

This principle is used in the *delta matching system* shown in **Fig 8**. The center impedance of a  $\lambda/2$  dipole is too low to be matched directly by any practical type of air-insulated parallel-conductor line. However, it is possible to find, between two points, a value of impedance that can be matched to such a line when a “fanned” section or delta is used to couple the line and antenna. The antenna length  $l$  is that required for resonance. The ends of the delta or “Y” should be attached at points equidistant from the center of the antenna. When so connected, the terminating impedance for the line will be resistive. Obviously, this technique is useful only when the  $Z_0$  of the chosen transmission line is



**Fig 7**—Impedance transformation with a resonant circuit, together with antenna analogy.

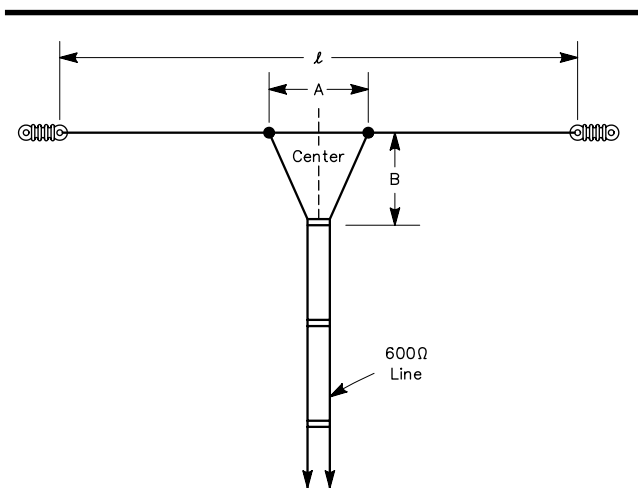


Fig 8—The delta matching system.

higher than the feed-point impedance of the antenna.

Based on experimental data for the case of a typical  $\lambda/2$  antenna coupled to a 600- $\Omega$  line, the total distance, A, between the ends of the delta should be  $0.120 \lambda$  for frequencies below 30 MHz, and  $0.115 \lambda$  for frequencies above 30 MHz. The length of the delta, distance B, should be  $0.150 \lambda$ . These values are based on a wavelength in air, and on the assumption that the center impedance of the antenna is approximately 70  $\Omega$ . The dimensions will require modifications if the actual impedance is very much different.

The delta match can be used for matching the driven element of a directive array to a transmission line, but if the impedance of the element is low—as is frequently the case—the proper dimensions for A and B must be found by experimentation.

The delta match is somewhat awkward to adjust when the proper dimensions are unknown, because both the length and width of the delta must be varied. An additional disadvantage is that there is always some radiation from the delta. This is because the conductor spacing does not meet the requirement for negligible radiation: The spacing should be very small in comparison with the wavelength.

### Folded Dipoles

Basic information on the folded dipole antenna appears in Chapter 6. The input impedance of a two-wire folded dipole is so close to 300  $\Omega$  that it can be fed directly with 300- $\Omega$  twin-lead or with open-wire line without any other matching arrangement, and the line will operate with a low SWR. The antenna itself can be built like an open-wire line; that is, the two conductors can be held apart by regular feeder spreaders. TV ladder line is quite suitable. It is also possible to use 300- $\Omega$  line for the antenna, in addition to using it for the transmission line.

Since the antenna section does not operate as a

transmission line, but simply as two wires in parallel, the velocity factor of twin-lead can be ignored in computing the antenna length. The reactance of the folded-dipole antenna varies less rapidly with frequency changes away from resonance than a single-wire antenna. Therefore it is possible to operate over a wider range of frequencies, while maintaining a low SWR on the line, than with a simple dipole. This is partly explained by the fact that the two conductors in parallel form a single conductor of greater effective diameter.

A folded dipole will not accept power at twice the fundamental frequency. However, the current distribution is correct for harmonic operation on odd multiples of the fundamental. Because the feed-point resistance is not greatly different for a  $3\lambda/2$  antenna and one that is  $\lambda/2$ , a folded dipole can be operated on its third harmonic with a low SWR in a 300- $\Omega$  line. A 7-MHz folded dipole, consequently, can be used for the 21-MHz band as well.

## The T and Gamma Matches

### The T Match

The current flowing at the input terminals of the T match consists of the normal antenna current divided between the radiator and the T conductors in a way that depends on their relative diameters and the spacing between them, with a superimposed transmission-line current flowing in each half of the T and its associated section of the antenna. See Fig 9. Each such T conductor and the associated antenna conductor can be looked upon as a section of transmission line shorted at the end. Because it is shorter than  $\lambda/4$  it has inductive reactance. As a consequence, if the antenna itself is exactly resonant at the operating frequency, the input impedance of the T will show inductive reactance as well as resistance. The reactance must be tuned out if a good match to the transmission line is to be obtained. This can be done

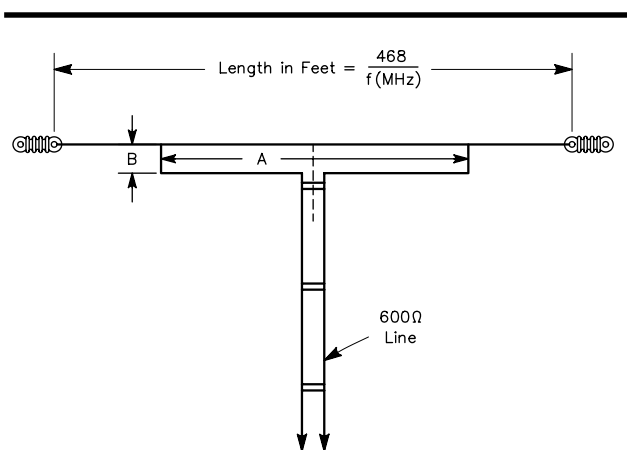


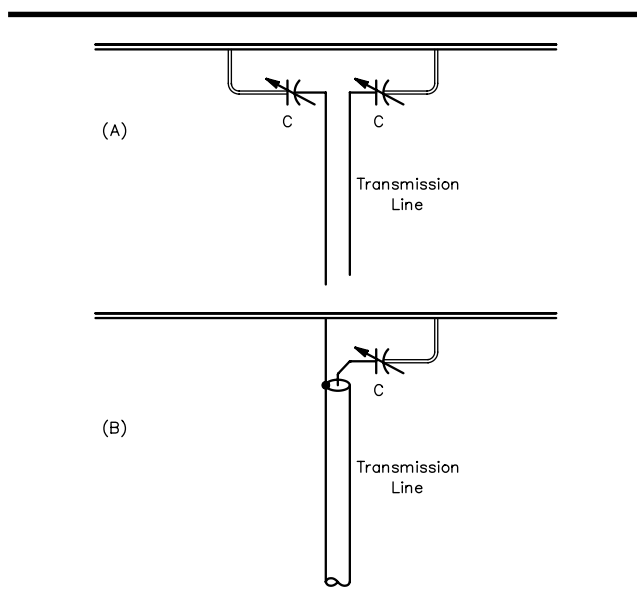
Fig 9—The T matching system, applied to a  $1/2\text{-}\lambda$  antenna and 600- $\Omega$  line.

either by shortening the antenna to obtain a value of capacitive reactance that will reflect through the matching system to cancel the inductive reactance at the input terminals, or by inserting a capacitance of the proper value in series at the input terminals as shown in **Fig 10A**.

Theoretical analyses have shown that the part of the impedance step-up arising from the spacing and ratio of conductor diameters is approximately the same as given for a folded dipole. The actual impedance ratio is, however, considerably modified by the length  $A$  of the matching section (**Fig 9**). The trends can be stated as follows:

- 1) The input impedance increases as the distance  $A$  is made larger, but not indefinitely. In general there is a distance  $A$  that will give a maximum value of input impedance, after which further increase in  $A$  will cause the impedance to decrease.
- 2) The distance  $A$  at which the input impedance reaches a maximum is smaller as  $d_2/d_1$  is made larger, and becomes smaller as the spacing between the conductors is increased.
- 3) The maximum impedance values occur in the region where  $A$  is 40% to 60% of the antenna length in the average case.
- 4) Higher values of input impedance can be realized when the antenna is shortened to cancel the inductive reactance of the matching section.

The T match has become popular for transforming the balanced feed-point impedance of a VHF or UHF Yagi up to



**Fig 10—Series capacitors for tuning out residual reactance with the T and gamma matching systems. A maximum capacitance of 150 pF in each capacitor should provide sufficient adjustment range, in the average case, for 14-MHz operation. Proportionately smaller capacitance values can be used on higher frequency bands. Receiving-type plate spacing will be satisfactory for power levels up to a few hundred watts.**

200  $\Omega$ . From that impedance a 4:1 balun is used to transform down to the unbalanced 50  $\Omega$  level for the coax cable feeding the Yagi. See the various K1FO Yagis in **Chapter 18** and the section later in this chapter concerning baluns.

### The Gamma Match

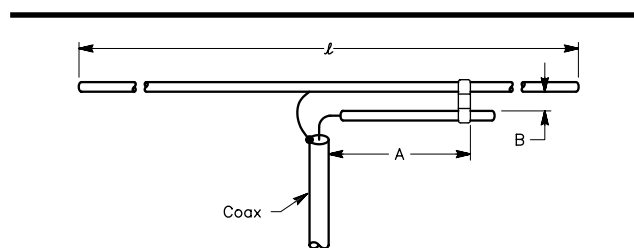
The gamma-match arrangement shown in **Fig 10B** is an unbalanced version of the T, suitable for use directly with coaxial lines. Except for the matching section being connected between the center and one side of the antenna, the remarks above about the behavior of the T apply equally well. The inherent reactance of the matching section can be canceled either by shortening the antenna appropriately or by using the resonant length and installing a capacitor  $C$ , as shown in **Fig 10B**.

For a number of years the gamma match has been widely used for matching coaxial cable to all-metal parasitic beams. Because it is well suited to *plumber's delight* construction, where all the metal parts are electrically and mechanically connected, it has become quite popular for amateur arrays.

Because of the many variable factors—driven-element length, gamma rod length, rod diameter, spacing between rod and driven element, and value of series capacitors—a number of combinations will provide the desired match. The task of finding a proper combination can be a tedious one, as the settings are interrelated. A few rules of thumb have evolved that provide a starting point for the various factors. For matching a multielement array made of aluminum tubing to 50- $\Omega$  line, the length of the rod should be 0.04 to 0.05  $\lambda$ , its diameter  $1/3$  to  $1/2$  that of the driven element, and its spacing (center-to-center from the driven element), approximately 0.007  $\lambda$ . The capacitance value should be approximately 7 pF per meter of wavelength. This translates to about 140 pF for 20-meter operation. The exact gamma dimensions and value for the capacitor will depend on the radiation resistance of the driven element, and whether or not it is resonant. These starting-point dimensions are for an array having a feed-point impedance of about 25  $\Omega$ , with the driven element shortened approximately 3% from resonance.

### Calculating Gamma Dimensions

A starting point for the gamma dimensions and capacitance value may be determined by calculation.



**Fig 11—The gamma match, as used with tubing elements. The transmission line may be either 50- $\Omega$  or 75- $\Omega$  coax.**



H. F. Tolles, W7ITB, has developed a method for determining a set of parameters that will be quite close to providing the desired impedance transformation. (See Bibliography at the end of this chapter.) The impedance of the antenna must be measured or computed for Tolles' procedure. If the antenna impedance is not accurately known, modeling calculations provide a very good starting point for initial settings of the gamma match.

The math involved in Tolles' procedure is tedious, especially if several iterations are needed to find a practical set of dimensions. The procedure has been adapted for computer calculations by R. A. Nelson, WB0IKN, who wrote his program in Applesoft BASIC (see Bibliography). A similar program for the IBM PC and compatible computers called *GAMMA* is included on the CD-ROM bundled with this book, in BASIC source code, with modifications suggested by Dave Leeson, W6NL. The program can be used for calculating a gamma match for a dipole (or driven element of an array) or for a vertical monopole, such as a shunt-fed tower.

As an example of computer calculations, assume a 14.3-MHz Yagi beam is to be matched to 50- $\Omega$  line. The driven element is 1½ inches in diameter, and the gamma rod is a length of ½-inch tubing, spaced 6 inches from the element (center to center). The driven element has been shortened by 3% from its resonant length. Assume the antenna has a radiation resistance of 25  $\Omega$  and a capacitive reactance component of 25  $\Omega$  (about the reactance that would result from the 3% shortening). The overall impedance of the driven element is therefore 25 – j 25  $\Omega$ . At the program prompts, enter the choice for a dipole, the frequency, the feed-point resistance and reactance (don't forget the minus sign), the line characteristic impedance (50  $\Omega$ ), and the element and rod diameters and center-to-center spacing. *GAMMA* computes that the gamma rod is 38.9 inches long and the gamma capacitor is 96.1 pF at 14.3 MHz.

As another example, say we wish to shunt feed a tower at 3.5 MHz with 50- $\Omega$  line. The driven element (tower) is 12 inches in diameter, and #12 wire (diameter = 0.0808 inch) with a spacing of 12 inches from the tower is to be used for the "gamma rod." The tower is 50 feet tall with a 5-foot mast and beam antenna at the top. The total height, 55 feet, is approximately 0.19  $\lambda$ . We assume its electrical length is 0.2  $\lambda$  or 72°. Modeling shows that the approximate base feed-point impedance is 20 – j 100  $\Omega$ . *GAMMA* says that the gamma rod should be 57.1 feet long, with a gamma capacitor of 32.1 pF.

Immediately we see this set of gamma dimensions is impractical—the rod length is greater than the tower height. So we make another set of calculations, this time using a spacing of 18 inches between the rod and tower. The results this time are that the gamma rod is 49.3 feet long, with a capacitor of 43.8 pF. This gives us a practical set of starting dimensions for the shunt-feed arrangement.

### Adjustment

After installation of the antenna, the proper constants

for the T and gamma generally must be determined experimentally. The use of the variable series capacitors, as shown in Fig 10, is recommended for ease of adjustment. With a trial position of the tap or taps on the antenna, measure the SWR on the transmission line and adjust C (both capacitors simultaneously in the case of the T) for minimum SWR. If it is not close to 1:1, try another tap position and repeat. It may be necessary to try another size of conductor for the matching section if satisfactory results cannot be brought about. Changing the spacing will show which direction to go in this respect.

### The Omega Match

The omega match is a slightly modified form of the gamma match. In addition to the series capacitor, a shunt capacitor is used to aid in canceling a portion of the inductive reactance introduced by the gamma section. This is shown in Fig 12. C1 is the usual series capacitor. The addition of C2 makes it possible to use a shorter gamma rod, or makes it easier to obtain the desired match when the driven element is resonant. During adjustment, C2 will serve primarily to determine the resistive component of the load as seen by the coax line, and C1 serves to cancel any reactance.

### The Hairpin and Beta Matches

The usual form of the *hairpin match* is shown in Fig 13. Basically, the hairpin is a form of an L-matching network. Because it is somewhat easier to adjust for the desired terminating impedance than the gamma match, it is preferred by many amateurs. Its disadvantages, compared with the gamma, are that it must be fed with a balanced line (a balun may be used with a coax feeder, as shown in Fig 13—see the section later in this chapter about baluns), and the driven element must be split at the center. This latter requirement complicates the mechanical mounting arrangement for the element, by ruling out *plumber's delight* construction.

As indicated in Fig 13, the center point of the hairpin is electrically neutral. As such, it may be grounded or

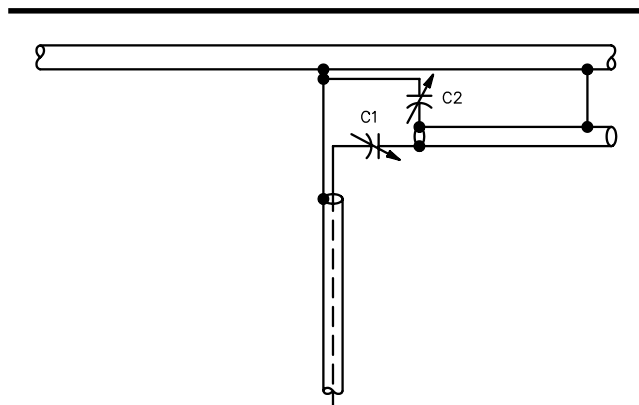
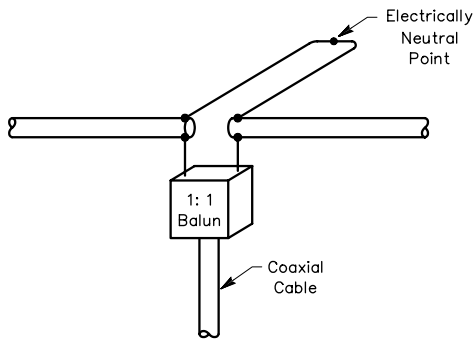
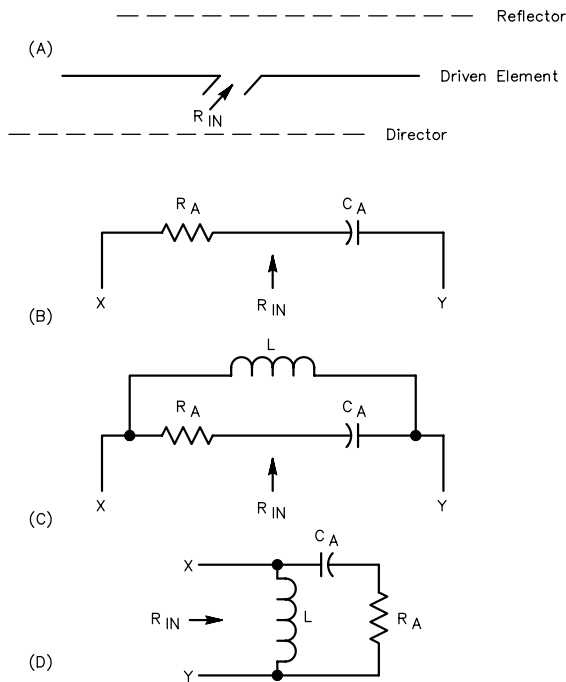


Fig 12—The omega match.



**Fig 13—The hairpin match.**

connected to the remainder of the antenna structure. The hairpin itself is usually secured by attaching this neutral point to the boom of the antenna array. The Hy-Gain *beta match* is electrically identical to the hairpin match, the difference being in the mechanical construction of the matching section. With the beta match, the conductors of the matching section straddle the Yagi's boom, one conductor being located on either side, and the electrically neutral point consists of a sliding or adjustable shorting clamp placed around the boom

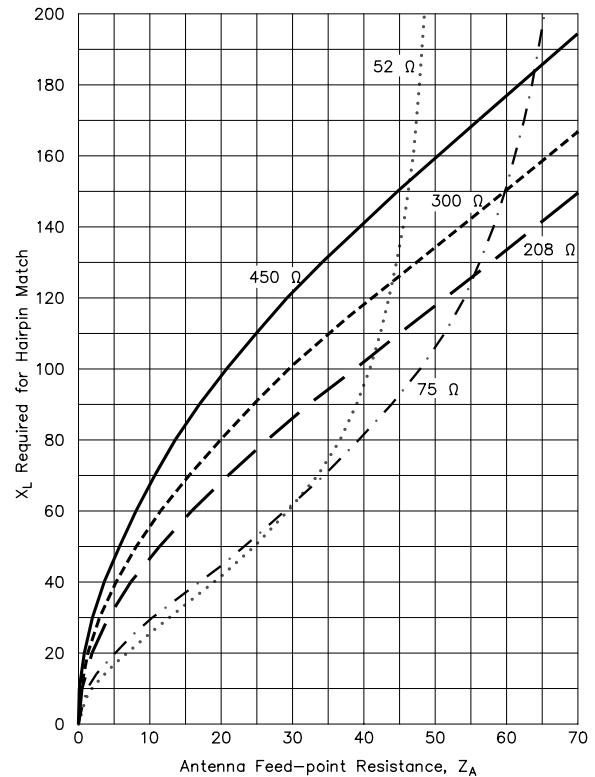


**Fig 14—For the Yagi antenna shown at A, the driven element is shorter than its resonant length. The input impedance at resonance is represented at B. By adding an inductor, as shown at C, a low value of  $R_A$  is made to appear as a higher impedance at terminals XY. At D, the diagram of C is redrawn in the usual L-network configuration.**

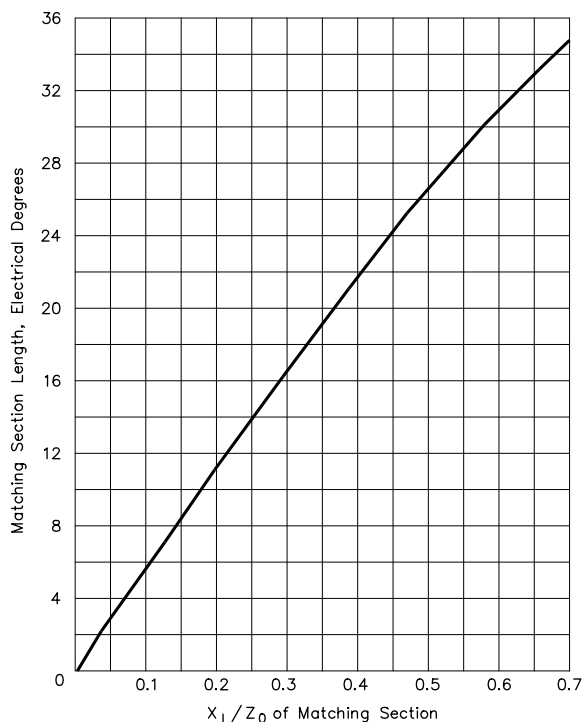
and the two matching-section conductors.

The capacitive portion of the L-network circuit is produced by slightly shortening the antenna driven element, shown in **Fig 14A**. For a given frequency the impedance of a shortened  $\lambda/2$  element appears as the antenna resistance and a capacitance in series, as indicated schematically in **Fig 14B**. The inductive portion of the resonant circuit at C is a hairpin of heavy wire or small tubing which is connected across the driven-element center terminals. The diagram of C is redrawn in D to show the circuit in conventional L-network form.  $R_A$ , the radiation resistance, is a smaller value than  $R_{IN}$ , the impedance of the feed line.

If the approximate radiation resistance of the antenna system is known, **Figs 15** and **16** may be used to gain an idea of the hairpin dimensions necessary for the desired match. The curves of **Fig 15** were obtained from design equations for L-network matching. **Fig 15** is based on the equation,  $X_p = j \tan \theta$ , which gives the inductive reactance as normalized to the  $Z_0$  of the hairpin, looking at it as a length of transmission line terminated in a short circuit. For example, if an antenna-system impedance of  $20 \Omega$  is to be matched to  $50\text{-}\Omega$  line, **Fig 16** indicates that the inductive reactance required for the hairpin is  $41 \Omega$ . If the hairpin is constructed of  $1/4$ -inch tubing spaced  $1\frac{1}{2}$  inches, its characteristic



**Fig 15—Reactance required for a hairpin to match various antenna resistances to common line or balun impedance.**



**Fig 16—Inductive reactance (normalized to  $Z_0$  of matching section), scale at bottom, versus required hairpin matching section length, scale at left. To determine the length in wavelengths divide the number of electrical degrees by 360. For open-wire line, a velocity factor of 97.5% should be taken into account when determining the electrical length.**

impedance is  $300 \Omega$  (from Chapter 24.) Normalizing the required  $41\text{-}\Omega$  reactance to this impedance,  $41/300 = 0.137$ .

By entering the graph of Fig 16 with this value, 0.137, on the scale at the bottom, you can see that the hairpin length should be 7.8 electrical degrees, or  $7.8/360 \lambda$ . For purposes of these calculations, taking a 97.5% velocity factor into account, the wavelength in inches is  $11,508/f(\text{MHz})$ . If the antenna is to be used on 14 MHz, the required hairpin length is  $7.8/360 \times 11,508/14 = 17.8$  inches. The length of the hairpin affects primarily the resistive component of the terminating impedance, as seen by the feed line. Greater resistances are obtained with longer hairpin sections—meaning a larger value of shunt inductor—and smaller resistances with shorter sections. Reactance at the feed-point terminals is tuned out by adjusting the length of the driven element, as necessary. If a fixed-length hairpin section is in use, a small range of adjustment may be made in the effective value of the inductance by spreading or squeezing together the conductors of the hairpin. Spreading the conductors apart will have the same effect as lengthening the hairpin, while placing them closer together will effectively shorten it.

Instead of using a hairpin of stiff wire or tubing, this same matching technique may be used with a lumped-

constant inductor connected across the antenna terminals. Such a method of matching has been dubbed, tongue firmly in cheek, as the “helical hairpin.” The inductor, of course, must exhibit the same reactance at the operating frequency as the hairpin which it replaces. A cursory examination with computer calculations indicates that a helical hairpin may offer a slightly improved SWR bandwidth over a true hairpin, but the effects of different length/diameter ratios of the driven element were not investigated.

### Matching Stubs

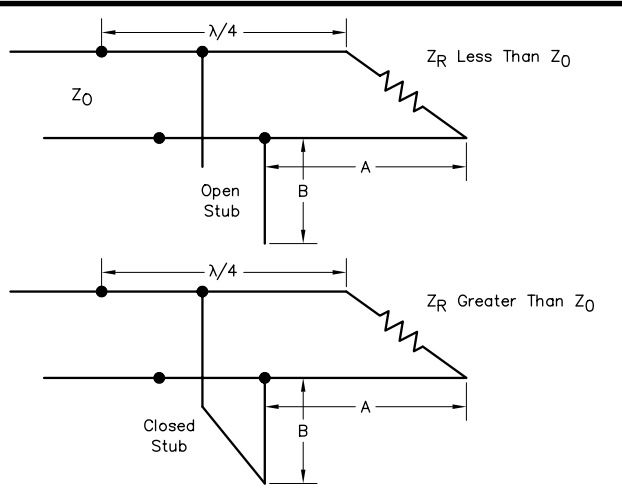
As explained in Chapter 24, a mismatch-terminated transmission line less than  $\lambda/4$  long has an input impedance that is both resistive and reactive. The equivalent circuit of the line input impedance at any one frequency can be formed either of resistance and reactance in series, or resistance and reactance in parallel. Depending on the line length, the series resistance component,  $R_S$ , can have any value between the terminating resistance  $Z_R$  (when the line has zero length) and  $Z_0^2/Z_R$  (when the line is exactly  $\lambda/4$  long). The same thing is true of  $R_P$ , the parallel-resistance component.

$R_S$  and  $R_P$  do not have the same values at the same line length, however, other than zero and  $\lambda/4$ . With either equivalent there is some line length that will give a value of  $R_S$  or  $R_P$  equal to the characteristic impedance of the line. However, there will be reactance along with the resistance. But if provision is made for canceling or tuning out this reactive part of the input impedance, only the resistance will remain. Since this resistance is equal to the  $Z_0$  of the transmission line, the section from the reactance-cancellation point back to the generator will be properly matched.

Tuning out the reactance in the equivalent series circuit requires that a reactance of the same value as  $X_S$  (but of opposite kind) be inserted in series with the line. Tuning out the reactance in the equivalent parallel circuit requires that a reactance of the same value as  $X_P$  (but of opposite kind) be connected across the line. In practice it is more convenient to use the parallel-equivalent circuit. The transmission line is simply connected to the load (which of course is usually a resonant antenna) and then a reactance of the proper value is connected across the line at the proper distance from the load. From this point back to the transmitter there are no standing waves on the line.

A convenient type of reactance to use is a section of transmission line less than  $\lambda/4$  long, terminated with either an open circuit or a short circuit, depending on whether capacitive reactance or inductive reactance is called for. Reactances formed from sections of transmission line are called *matching stubs*, and are designated as *open* or *closed* depending on whether the free end is open or short circuited. The two types of matching stubs are shown in the sketches in Fig 17.

The distance from the load to the stub (dimension A in Fig 17) and the length of the stub, B, depend on the characteristic impedances of the line and stub and on the ratio of  $Z_R$  to  $Z_0$ . Since the ratio of  $Z_R$  to  $Z_0$  is also the standing-wave ratio in the absence of matching (and with a



**Fig 17—Use of open or closed stubs for canceling the parallel reactive component of input impedance.**

resonant antenna), the dimensions are a function of the SWR. If the line and stub have the same  $Z_0$ , dimensions A and B are dependent on the SWR only. Consequently, if the SWR can be measured before the stub is installed, the stub can be properly located and its length determined even though the actual value of load impedance is not known.

Typical applications of matching stubs are shown in **Fig 18**, where open-wire line is being used. From inspection of these drawings it will be recognized that when an antenna is fed at a current loop, as in Fig 18A,  $Z_R$  is less than  $Z_0$  (in the average case) and therefore an open stub is called for, installed within the first  $\lambda/4$  of line measured from the antenna. Voltage feed, as at B, corresponds to  $Z_R$  greater than  $Z_0$  and therefore requires a closed stub.

The Smith Chart may be used to determine the length of the stub and its distance from the load (see **Chapter 28**) or the ARRL program *TLW* on the CD-ROM in the back of this book may be used. If the load is a pure resistance and the characteristic impedances of the line and stub are identical, the lengths may be determined by equations. For the closed stub when  $Z_R$  is greater than  $Z_0$ , they are

$$A = \arctan \sqrt{\text{SWR}} \quad (\text{Eq 12})$$

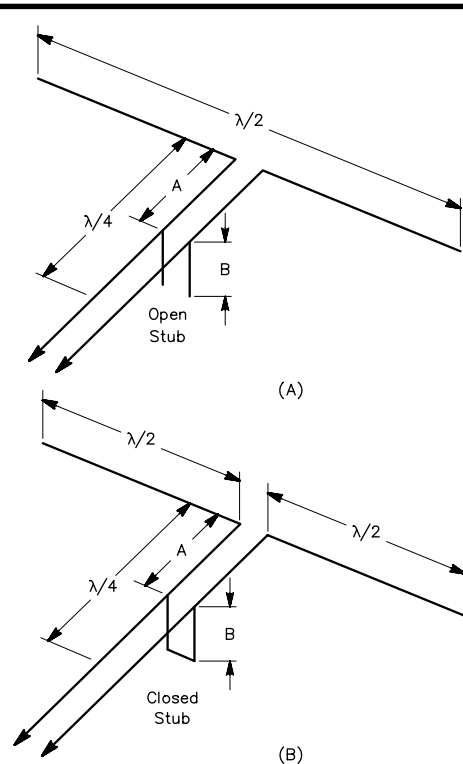
$$B = \arctan \frac{\sqrt{\text{SWR}}}{\text{SWR} - 1} \quad (\text{Eq 13})$$

For the open stub when  $Z_R$  is less than  $Z_0$

$$A = \arctan \frac{1}{\sqrt{\text{SWR}}} \quad (\text{Eq 14})$$

$$B = \arctan \frac{\text{SWR} - 1}{\sqrt{\text{SWR}}} \quad (\text{Eq 15})$$

In these equations the lengths A and B are the distance from the stub to the load and the length of the stub, respectively, as shown in Fig 18. These lengths are expressed



**Fig 18—Application of matching stubs to common types of antennas.**

in electrical degrees, equal to 360 times the lengths in wavelengths.

In using the above equations it must be remembered that the wavelength along the line is not the same as in free space. If an open-wire line is used the velocity factor of 0.975 will apply. When solid-dielectric line is used, the free-space wavelength as determined above must be multiplied by the appropriate velocity factor to obtain the actual lengths of A and B (see **Chapter 24**.)

Although the equations above do not apply when the characteristic impedances of the line and stub are not the same, this does not mean that the line cannot be matched under such conditions. The stub can have any desired characteristic impedance if its length is chosen so that it has the proper value of reactance. By using the Smith Chart, the correct lengths can be determined without difficulty for dissimilar types of line.

In using matching stubs it should be noted that the length and location of the stub should be based on the SWR at the load. If the line is long and has fairly high losses, measuring the SWR at the input end will not give the true value at the load. This point is discussed in **Chapter 24** in the section on attenuation.

### Reactive Loads

In this discussion of matching stubs it has been assumed that the load is a pure resistance. This is the most desirable

condition, since the antenna that represents the load preferably should be tuned to resonance before any attempt is made to match the line. Nevertheless, matching stubs can be used even when the load is considerably reactive. A reactive load simply means that the loops and nodes of the standing waves of voltage and current along the line do not occur at integral multiples of  $\lambda/4$  from the load. If the reactance at the load is known, the Smith Chart or TLW may be used to determine the correct dimensions for a stub match.

### Stubs on Coaxial Lines

The principles outlined in the preceding section apply also to coaxial lines. The coaxial cases corresponding to the open-wire cases shown in Fig 18 are given in Fig 19. The equations given earlier may be used to determine dimensions A and B. In a practical installation the junction of the transmission line and stub would be a T connector.

A special case is the use of a coaxial matching stub, in which the stub is associated with the transmission line in such a way as to form a balun. This is described in detail later on in this chapter. The antenna is shortened to introduce just enough reactance at its feed point to permit the matching stub to be connected there, rather than at some other point along the transmission line as in the general cases discussed here. To use this method the antenna resistance must be lower than the  $Z_0$  of the main transmission line, since the resistance is transformed to a higher value. In beam antennas such as Yagis, this will nearly always be the case.

### Matching Sections

If the two antenna systems in Fig 18 are redrawn in somewhat different fashion, as shown in Fig 20, a system

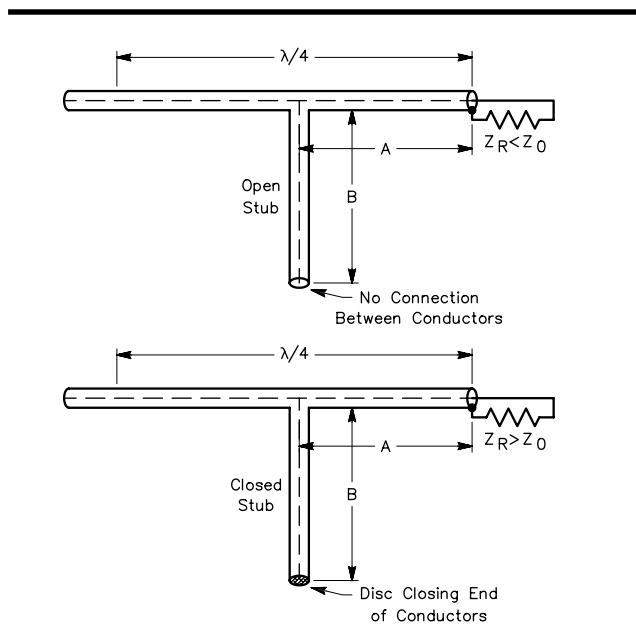


Fig 19—Open and closed stubs on coaxial lines.

results that differs in no consequential way from the matching stubs described previously, but in which the stub formed by A and B together is called a *quarter-wave matching section*. The justification for this is that a  $\lambda/4$  section of line is similar to a resonant circuit, as described earlier in this chapter. It is therefore possible to use the  $\lambda/4$  section to transform impedances by tapping at the appropriate point along the line.

Earlier equations give design data for matching sections, A being the distance from the antenna to the point at which the line is connected, and A + B being the total length of the matching section. The equations apply only in the case where the characteristic impedance of the matching section and transmission line are the same. Equations are available for the case where the matching section has a different  $Z_0$  than the line, but are somewhat complicated. A graphic solution for different line impedances may be obtained with the Smith Chart (Chapter 28).

### Adjustment

In the experimental adjustment of any type of matched line it is necessary to measure the SWR with fair accuracy

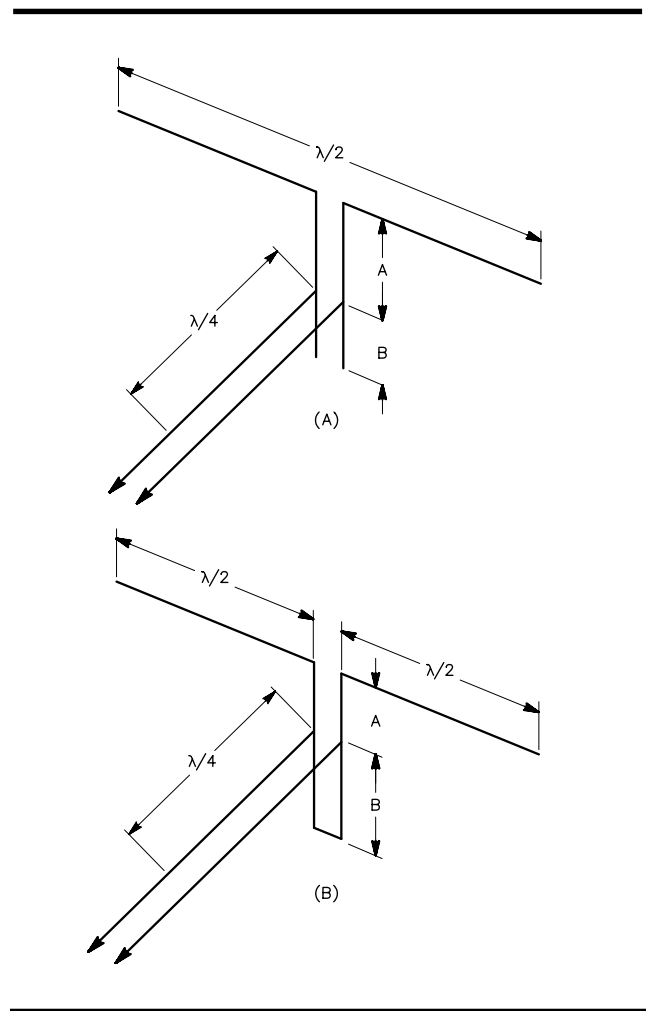


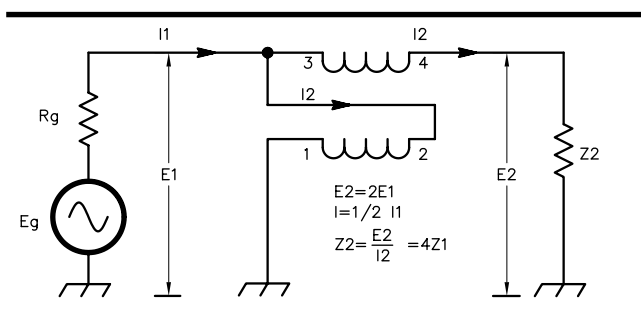
Fig 20—Application of matching sections to common antenna types.

in order to tell when the adjustments are being made in the proper direction. In the case of matching stubs, experience has shown that experimental adjustment is unnecessary, from a practical standpoint, if the SWR is first measured with the stub not connected to the transmission line, and the stub is then installed according to the design data.

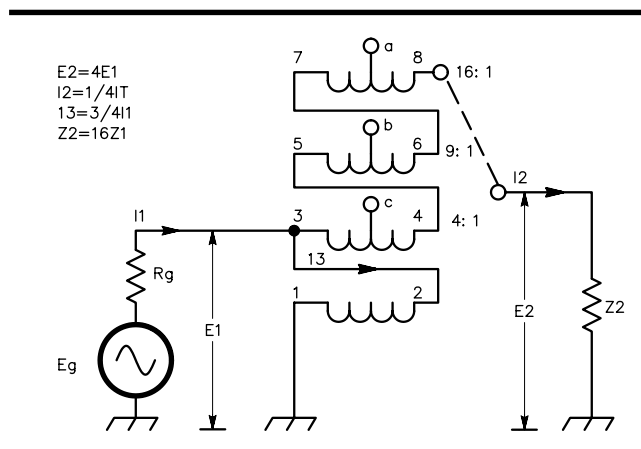
### Broadband Matching Transformers

Broadband transformers have been used widely because of their inherent bandwidth ratios (as high as 20,000:1) from a few tens of kilohertz to over a thousand megahertz. This is possible because of the transmission-line nature of the windings. The interwinding capacitance is a component of the characteristic impedance and therefore, unlike a conventional transformer, forms no resonances that seriously limit the bandwidth.

At low frequencies, where interwinding capacitances can be neglected, these transformers are similar in operation to a conventional transformer. The main difference (and a very important one from a power standpoint) is that the windings tend to cancel out the induced flux in the core.



**Fig 21—Broadband bifilar transformer with a 4:1 impedance ratio. The upper winding can be tapped at appropriate points to obtain other ratios such as 1.5:1, 2:1 and 3:1.**

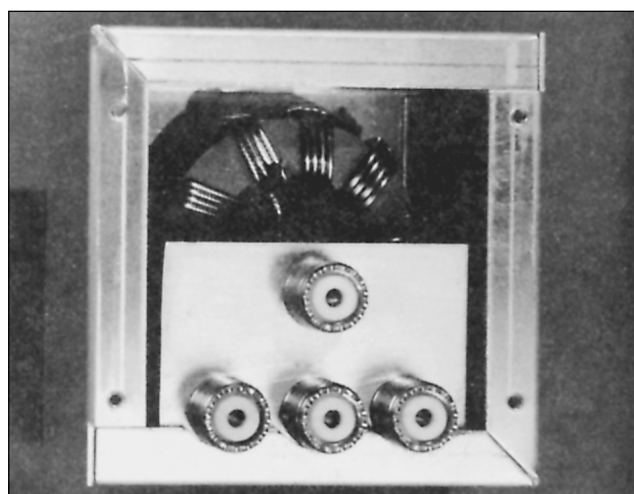


**Fig 22—Four-winding, broadband, variable impedance transformer. Connections a, b and c can be placed at appropriate points to yield various ratios from 1.5:1 to 16:1.**

Thus, high permeability ferrite cores, which are not only highly nonlinear but also suffer serious damage even at flux levels as low as 200 to 500 gauss, can be used. This greatly extends the low frequency range of performance. Since higher permeability also permits fewer turns at the lower frequencies, HF performance is also improved since the upper cutoff is determined mainly from transmission line considerations. At the high frequency cutoff, the effect of the core is negligible.

Bifilar matching transformers lend themselves to unbalanced operation. That is, both input and output terminals can have a common ground connection. This eliminates the third magnetizing winding required in balanced to unbalanced (*voltage balun*) operation. By adding third and fourth windings, as well as by tapping windings at appropriate points, various combinations of broadband matching can be obtained. **Fig 21** shows a 4:1 unbalanced to unbalanced configuration using #14 wire. It will easily handle 1000 W of power. By tapping at points  $1/4$ ,  $1/2$  and  $3/4$  of the way along the top winding, ratios of approximately 1.5:1, 2:1 and 3:1 can also be obtained. One of the wires should be covered with vinyl electrical tape in order to prevent voltage breakdown between the windings. This is necessary when a step-up ratio is used at high power to match antennas with impedances greater than 50  $\Omega$ .

**Fig 22** shows a transformer with four windings, permitting wide-band matching ratios as high as 16:1. **Fig 23** shows a four-winding transformer with taps at 4:1, 6:1, 9:1, and 16:1. In tracing the current flow in the windings, when using the 16:1 tap, one sees that the top three windings carry the same current. The bottom winding, in order to maintain the proper potentials, sustains a current three times greater. The bottom current cancels out the core flux caused by the other three windings. If this transformer is used to match



**Fig 23—A 4-winding, wide-band transformer (with front cover removed) with connections made for matching ratios of 4:1, 6:1, 9:1 and 16:1. The 6:1 ratio is the top coaxial connector and, from left to right, 16:1, 9:1 and 4:1 are the others. There are 10 quadrifilar turns of #14 enameled wire on a Q1, 2.5-in. OD ferrite core.**

into low impedances, such as 3 to 4  $\Omega$ , the current in the bottom winding can be as high as 15 amperes. This value is based on the high side of the transformer being fed with 50- $\Omega$  cable handling a kilowatt of power. If one needs a 16:1 match like this at high power, then cascading two 4:1 transformers is recommended. In this case, the transformer at the lowest impedance side requires each winding to handle only 7.5 A. Thus, even #14 wire would suffice in this application.

The popular cores used in these applications are 2.5 inches OD ferrites of Q1 and Q2 material, and powdered-iron cores of 2 inches OD. The permeabilities of these cores,  $\mu$ , are nominally 125, 40 and 10 respectively. Powdered-iron cores of permeabilities 8 and 25 are also available.

## Common-Mode Transmission-Line Currents

In discussions so far about transmission-line operation, it was always assumed that the two conductors carry equal and opposite currents throughout their length. This is an ideal condition that may or may not be realized in practice. In the average case, the chances are rather good that the currents will not be balanced unless special precautions are taken. The degree of imbalance—and whether that imbalance is actually important—is what we will examine in the rest of this chapter, along with measures that can be taken to restore balance in the system.

There are two common conditions that will cause an imbalance of transmission-line currents. Both are related to the symmetry of the system. The first condition involves the lack of symmetry when an inherently *unbalanced* coaxial line feeds a *balanced* antenna (such as a dipole or a Yagi driven element) directly. The second condition involves asymmetrical routing of a transmission line near the antenna it is feeding.

### UNBALANCED COAX FEEDING A BALANCED DIPOLE

Fig 24 shows a coaxial cable feeding a hypothetical balanced dipole fed in the center. The coax has been drawn highly enlarged to show all currents involved. In this drawing the feed line drops at right angles down from the feed point and the antenna is assumed to be perfectly symmetrical. Because of this symmetry, one side of the antenna induces current on the feed line that is completely cancelled by the current induced from the other side of the antenna.

Currents I1 and I2 from the transmitter flow on the inside of the coax. I1 flows on the *outer surface* of the coax's inner conductor and I2 flows on the *inner surface* of the shield. Skin effect keeps I1 and I2 inside the transmission line confined to where they are within the line. The field outside the coax is zero, since I1 and I2 have equal amplitudes but are 180° out of phase with respect to each other.

The currents flowing on the antenna itself are labeled I1 and I4, and both flow in the same direction at any instant in time for a resonant half-wave dipole. On Arm 1 of the dipole, I1 is shown going directly into the center conductor

In all cases these cores can be made to operate over the 1.8 to 28-MHz bands with full power capability and very low loss. The main difference in their design is that lower permeability cores require more turns at the lower frequencies. For example, Q1 material requires 10 turns to cover the 1.8-MHz band. Q2 requires 12 turns, and powdered-iron ( $\mu = 10$ ) requires 14 turns. Since the more common powdered iron core is generally smaller in diameter and requires more turns because of lower permeability, higher ratios are sometimes difficult to obtain because of physical limitations. When you are working with low impedance levels, unwanted parasitic inductances come into play, particularly on 14 MHz and above. In this case lead lengths should be kept to a minimum.

of the feed coax. However, the situation is different for the other side of this dipole. Once current I2 reaches the end of the coax, it splits into two components. One is I4, going directly into Arm 2 of the dipole. The other is I3 and this flows down the *outer surface* of the coax shield. Again, because of skin effect, I3 is separate and distinct from the current I2 on the inner surface. The antenna current in Arm 2 is thus equal to the difference between I2 and I3.

The magnitude of I3 is proportional to the relative impedances in each current path beyond the split. The feed-point impedance of the dipole by itself is somewhere between 50 to 75  $\Omega$ , depending on the height above ground. The impedance seen looking into one half of the dipole is half, or 25 to 37.5  $\Omega$ . The impedance seen looking down the outside surface of the coax's outer shield to ground is called the *common-mode impedance*, and I3 is aptly called the *common-mode current*. (The term common mode is more readily appreciated if parallel-conductor line is substituted

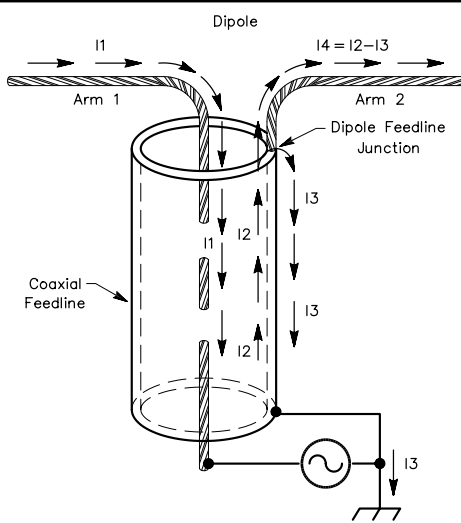


Fig 24—Drawing showing various current paths at feed point of a balanced dipole fed with unbalanced coaxial cable. The diameter of the coax is exaggerated to show currents clearly.

for the coaxial cable used in this illustration. Current induced by radiation onto both conductors of a two-wire line is a common-mode current, since it flows in the *same direction* on both conductors, rather than in opposite directions as it does for transmission-line current. The outer braid for a coaxial cable shields the inner conductor from such an induced current, but the unwanted current on the outside braid is still called *common-mode* current.)

The common-mode impedance will vary with the length of the coaxial feed line, its diameter and the path length from the transmitter chassis to whatever is actually “RF ground.” Note that the path from the transmitter chassis to ground may go through the station’s grounding bus, the transmitter power cord, the house wiring and even the power-line service ground. In other words, the overall length of the coaxial outer surface and the other components making up ground can actually be quite a bit different from what you might expect by casual inspection.

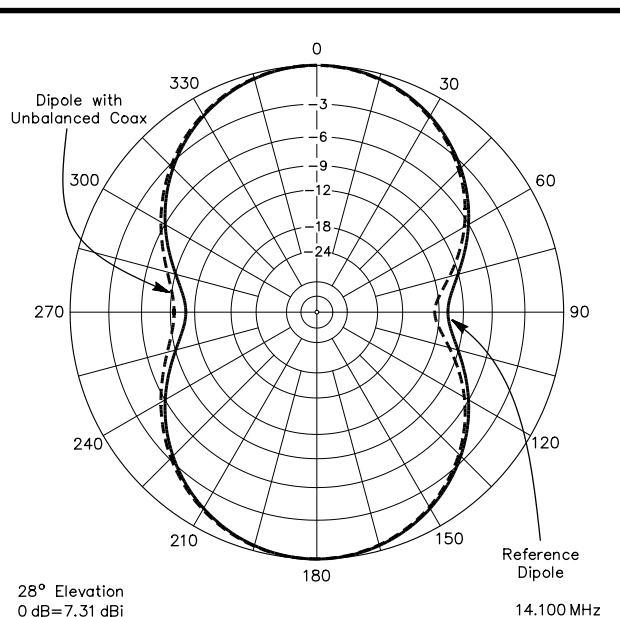
The worst-case common-mode impedance occurs when the overall effective path length to ground is an odd multiple of  $\lambda/2$ , making this path half-wave resonant. In effect, the line and ground-wire system acts like a sort of transmission line, transforming the short circuit to ground at its end to a low impedance at the dipole’s feed point. This causes I3 to be a significant part of I2.

I3 not only causes an imbalance in the amount of current flowing in each arm of the otherwise symmetrical dipole, but it also radiates by itself. The radiation in Fig 24 due to I3 would be mainly vertically polarized, since the coax is drawn as being mainly vertical. However the polarization is a mixture of horizontal and vertical, depending on the orientation of the ground wiring from the transmitter chassis to the rest of the station’s grounding system.

### Pattern Distortion for a Simple Dipole with Symmetrical Coax Feed

Fig 25 compares the azimuthal radiation pattern for two  $\lambda/2$ -long 14-MHz dipoles mounted horizontally  $\lambda/2$  above average ground. Both patterns were computed for a 28° elevation angle, the peak response for a  $\lambda/2$ -high dipole. The model for the first antenna, the reference dipole shown as a solid line, has no feed line associated with it—it is as though the transmitter were somehow remotely located right at the center of the dipole. This antenna displays a classical figure-8 pattern. Both side nulls dip symmetrically about 10 dB below the peak response, typical for a 20-meter dipole 33 feet above ground (or an 80-meter dipole placed 137 feet above ground).

The second dipole, shown as a dashed line, is modeled using a  $\lambda/2$ -long coaxial feed line dropped vertically to the ground below the feed point. Now, the azimuthal response of the second dipole is no longer perfectly symmetrical. It is shifted to the left a few dB in the area of the side nulls and the peak response is down about 0.1 dB compared to the reference dipole. Many would argue that this sort of response isn’t all that bad! However, do keep in mind that this is for a feed line placed in a symmetrical manner, at a right angle



**Fig 25—Comparison of azimuthal patterns of two  $\lambda/2$ -long 14-MHz dipoles mounted  $\lambda/2$  over average ground. The reference dipole without effect of feed-line distortion (modeled as though the transmitter were located right at the feed point) is the solid line. The dashed line shows the pattern for the dipole affected by common-mode current on its feed line due to the use of unbalanced coax to feed a balanced antenna. The feed line is dropped directly from the feed point to ground in a symmetrical manner. The feed-point impedance in this symmetrical configuration changes only a small amount compared to the reference antenna.**

below the dipole. Asymmetry in dressing the coax feed line will result in more pattern distortion.

### SWR Change with Common-Mode Current

If an SWR meter is placed at the bottom end of the coax feeding the second dipole, it would show an SWR of 1.38:1 for a 50- $\Omega$  coax such as RG-213, since the antenna’s feed-point impedance is  $69.20 + j 0.69 \Omega$ . The SWR for the reference dipole would be 1.39:1, since its feed-point impedance is  $69.47 - j 0.35 \Omega$ . As could be expected, the common-mode impedance in parallel with the dipole’s natural feed-point impedance has lowered the net impedance seen at the feed point, although the degree of impedance change is miniscule in this particular case with a symmetrical feed line dressed away from the antenna.

In theory at least, we have a situation where a change in the length of the unbalanced coaxial cable feeding a balanced dipole will cause the SWR on the line to change also. This is due to the changing common-mode impedance to ground at the feed point. The SWR may even change if the operator touches the SWR meter, since the path to RF ground is subtly altered when this happens. Even changing the length of an antenna to prune it for resonance may also



yield unexpected, and confusing, results on the SWR meter because of the common-mode impedance.

When the overall effective length of the coaxial feed line to ground is not an odd multiple of a  $\lambda/2$  resonant length but is an odd multiple of  $\lambda/4$ , the common-mode impedance transformed to the feed point is high in comparison to the dipole's natural feed-point impedance. This will cause I3 to be small in comparison to I2, meaning that radiation by I3 itself and the imbalance between I1 and I4 will be minimal. Modeling this case produces no difference in response between the dipole with unbalanced feed line and the reference dipole with no feed line. Thus, an odd multiple of a half-wave length for coax and ground wiring represents the *worst case* for this kind of imbalance, when the system is otherwise symmetrical.

If the coax in Fig 25 were replaced with balanced transmission line, the SWR would remain constant along the line, no matter what the length. (To put a fine point on it, the SWR would actually decrease slightly toward the transmitter end. This is because of line loss with SWR. However, the decrease would be slight, because the loss in open-wire balanced transmission line is small, even with relatively high SWR on the line. See Chapter 24 for a thorough discussion on additional line loss due to SWR.)

### Size of Coax

At HF, the diameter of the coax feeding a  $\lambda/2$  dipole is only a tiny fraction of the length of the dipole itself. In the case of Fig 25 above, the model of the coax used assumed an exaggerated 9-inch diameter, just to simulate a worst-case effect of coax spacing at HF.

However, on the higher UHF and microwave frequencies, the assumption that the coax spacing is not a significant portion of a wavelength is no longer true. The plane bisecting the feed point of the dipole in Fig 25 down through the space below the feed point and in-between the center conductor and shield of the coax is the "center" of the system. If the coax diameter is a significant percentage of the wavelength, the center is no longer symmetrical with reference to the dipole itself and significant imbalance will result. Measurements done at microwave frequencies showing extreme pattern distortion for balunless dipoles may well have suffered from this problem.

### ASYMMETRICAL ROUTING OF THE FEED LINE FOR A DIPOLE

Fig 25 shows a symmetrically located coax feed line, one that drops vertically at a  $90^\circ$  angle directly below the feed point of the symmetrical dipole. What happens if the feed line is not dressed away from the antenna in a completely symmetrical fashion—that is, not at a right angle to the dipole?

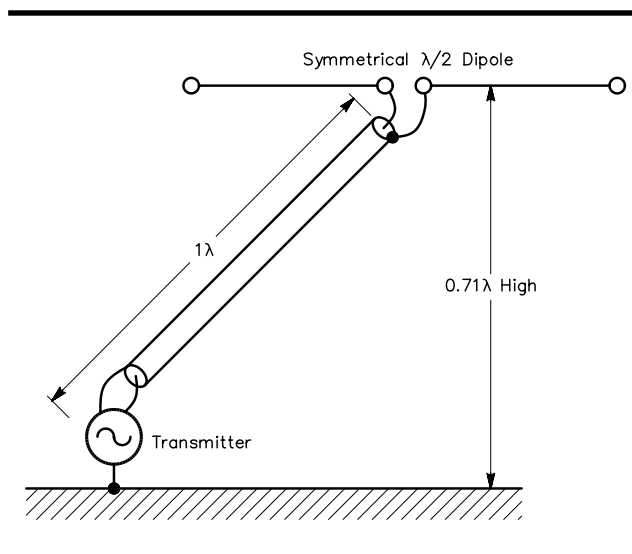
Fig 26 illustrates a situation where the feed line goes to the transmitter and ground at a  $45^\circ$  angle from the dipole. Now, one side of the dipole can radiate more strongly onto the feed line than the other half can. Thus, the currents radiated

onto the feed line from each half of the symmetrical dipole won't cancel each other. In other words, the antenna itself radiates a common-mode current onto the transmission line. This is a different form of common-mode current from what was discussed above in connection with an unbalanced coax feeding a balanced dipole, but it has similar effects.

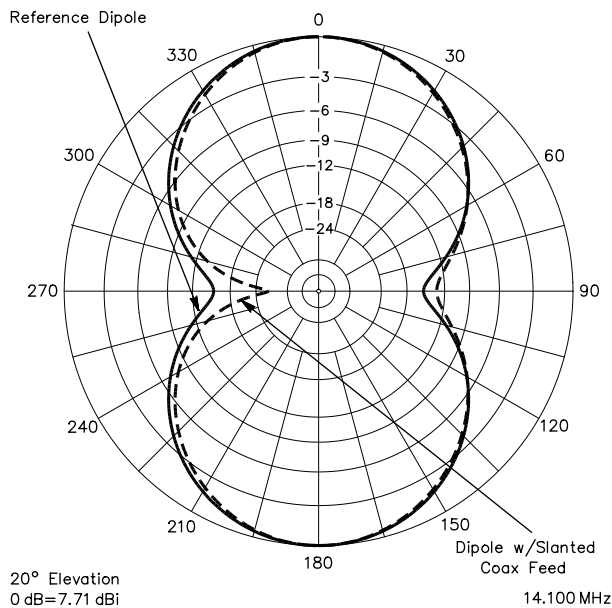
Fig 27 shows the azimuthal response of a  $0.71\lambda$ -high reference dipole with no feed line (as though the transmitter were located right at the feed point) compared to a  $0.71\lambda$ -high dipole that uses a  $1\lambda$ -long coax feed line, slanted  $45^\circ$  from the feed point down to ground through the transmitter. The  $0.71\lambda$  height was used so that the slanted coax could be exactly  $1\lambda$  long, directly grounded at its end through the transmitter and so that the low-elevation angle response could be emphasized to show pattern distortion. The feed line was made  $1\lambda$  long in this case, because when the feed line length is only  $0.5\lambda$  and is slanted  $45^\circ$  to ground, the height of the dipole is only  $0.35\lambda$ . This low height masks changes in the nulls in the azimuthal response due to feed line common-mode currents. Worst-case pattern distortion occurs for lengths that are multiples of  $\lambda/2$ , as before.

The degree of pattern distortion is now slightly worse than that for the symmetrically placed coax, but once again, the overall effect is not really severe. Interestingly enough, the slanted-feed line dipole actually has about 0.2 dB more gain than the reference dipole. This is because the left-hand side null is deeper for the slanted-feed line antenna, adding power to the frontal lobes at  $0^\circ$  and  $180^\circ$ .

The feed-point impedance for this dipole with slanted feed line is  $62.48 - j 1.28 \Omega$  for an SWR of 1.25:1, compared to the reference dipole's feed-point impedance of



**Fig 26—Drawing of  $\lambda/2$  dipole, placed  $0.71\lambda$  above average ground, with a  $1\lambda$  long coax feed line connected at far end to ground through a transmitter. Worst-case feed line radiation due to common-mode current induced on the outer shield braid occurs for lengths that are multiples of  $\lambda/2$ .**



**Fig 27—Azimuthal response for two dipoles placed as shown in Fig 26. The solid line represents a reference dipole with no feed line (modeled as though the transmitter were located directly at the feed point). The dashed line shows the response of the antenna with feed line slanted 45° down to ground. Current induced on the outer braid of the 1-λ-long coax by its asymmetry with respect to the antenna causes the pattern distortion. The feed-point impedance also changes, causing a different SWR from that for the unaffected reference dipole.**

72.00 + j 16.76 Ω for an SWR of 1.59:1. Here, the reactive part of the net feed-point impedance is smaller than that for the reference dipole, indicating that detuning has occurred due to mutual coupling to its own feed line. This change of SWR is slightly larger than for the previous case and could be seen on a typical SWR meter.

You should recognize that common-mode current arising from radiation from a balanced antenna back onto its transmission line due to a lack of symmetry occurs for *both* coaxial or balanced transmission lines. For a coax, the inner surface of the shield and the inner conductor are shielded from such radiation by the outer braid. However, the outer surface of the braid carries common-mode current radiated from the antenna and then subsequently reradiated by the line. For a balanced line, common-mode current are induced onto both conductors of the balanced line, again resulting in reradiation from the balanced line.

If the *antenna or its environment* are not perfectly symmetrical in all respects, there will also be some degree of common-mode current generated on the transmission line, either coax or balanced. Perfect symmetry means that the ground would have to be perfectly flat everywhere under the antenna, and that the physical length of each leg of the antenna would have to be exactly the same. It also means

that the height of the dipole must be exactly symmetrical all along its length, and it even means that nearby conductors, such as power lines, must be completely symmetrical with respect to the antenna.

In the real world, where the ground isn't always perfectly flat under the whole length of a dipole and where wire legs aren't cut with micrometer precision, a balanced line feeding a supposedly balanced antenna is no guarantee that common-mode transmission-line currents will not occur! However, dressing the feed line so that it is symmetrical to the antenna will lead to fewer problems in all cases.

## COMMON-MODE EFFECTS WITH DIRECTIONAL ANTENNAS

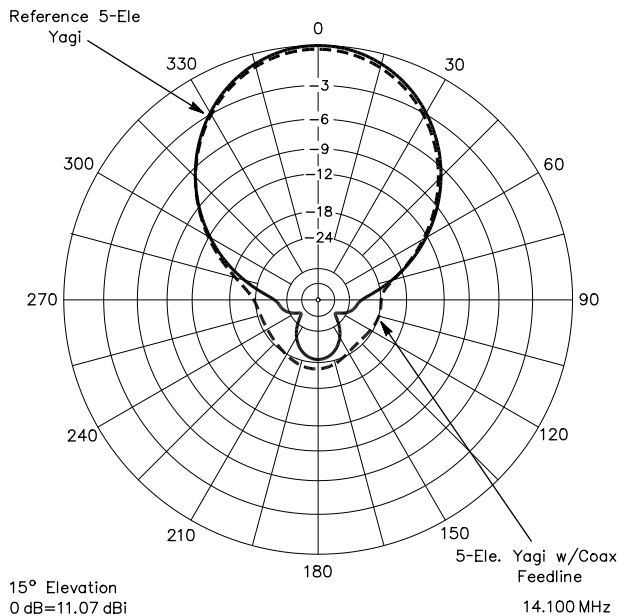
For a simple dipole, many amateurs would look at Fig 25 or Fig 27 and say that the worst-case pattern asymmetry doesn't look very important, and they would be right. Any minor, unexpected change in SWR due to common-mode current would be shrugged off as inconsequential—if indeed it is even noticed. All around the world, there are many thousands of coax-fed dipoles in use, where no special effort has been made to smooth the transition from unbalanced coax to balanced dipole.

For antennas that are specifically designed to be highly directional, however, pattern deterioration resulting from common-mode currents is a very different matter. Much care is usually taken during design of a directional antenna like a Yagi or a quad to tune each element in the system for the best compromise between directional pattern, gain and SWR bandwidth. What happens if we feed such a carefully tailored antenna in a fashion that creates common-mode feed line currents?

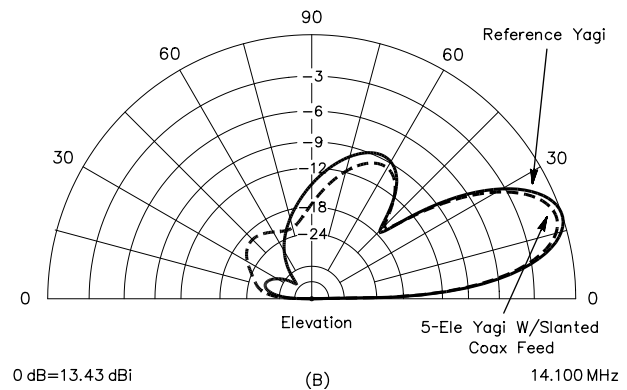
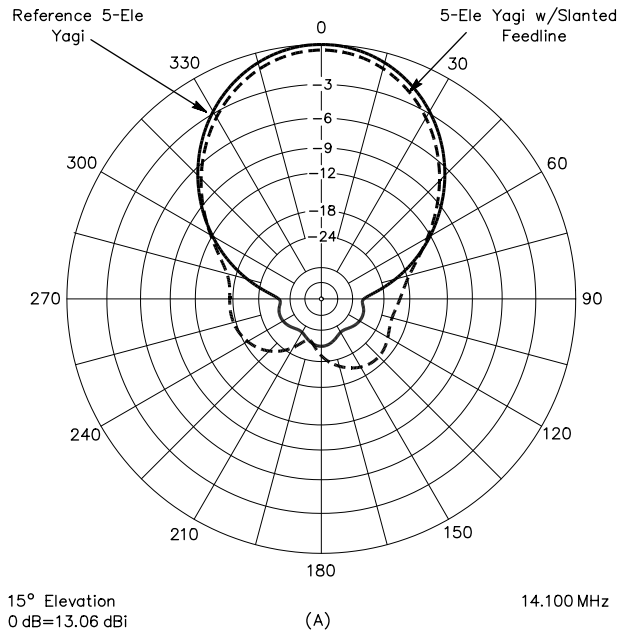
Fig 28 compares the azimuthal response of two five-element 20-meter Yagis, each located horizontally λ/2 above average ground. The solid line represents the reference antenna, where it is assumed that the transmitter is located right at the balanced driven element's feed point without the need for an intervening feed line. The dashed line represents the second Yagi, which is modeled with a λ/2-long unbalanced coaxial feed line going to ground directly under the balanced driven element's feed point.

Minor pattern skewing evident in the case of the dipole now becomes definite deterioration in the rearward pattern of the otherwise superb pattern of the reference Yagi. The side nulls deteriorate from more than 40 dB to about 25 dB. The rearward lobe at 180° goes from 26 dB to about 22 dB. In short, the pattern gets a bit ugly and the gain decreases as well.

Fig 29 shows a comparison at 0.71 λ height between a reference Yagi with no feed line and a Yagi with a 1-λ-long feed line slanted 45° to ground. Side nulls that were deep (at more than 30 dB down) for the reference Yagi have been reduced to less than 18 dB in the common-mode afflicted antenna. The rear lobe at 180° has deteriorated mildly, from 28 dB to about 26 dB. The forward gain of the antenna has fallen 0.4 dB from that of the reference antenna. As expected,



**Fig 28—Azimuthal response for two five-element 20-meter Yagis placed  $\lambda/2$  over average ground. The solid line represents an antenna fed with no feed line, as though the transmitter were located right at the feed point. The dashed line represents a dipole fed with a  $\lambda/2$  length of unbalanced coax line directly going to ground (through a transmitter at ground level). The distortion in the rearward pattern is evident, and the Yagi loses a small amount of forward gain (0.3 dB) compared to the reference antenna. In this case, placing a common-mode choke of  $+j 1000 \Omega$  at the feed point eliminated the pattern distortion.**



**Fig 29— At A, azimuthal response for two five-element 20-meter Yagis placed  $0.71 \lambda$  over average ground. The solid line represents an antenna fed with no feed line. The dashed line represents a dipole fed with a  $1-\lambda$  length of unbalanced coax line slanted at  $45^\circ$  to ground (through a transmitter at ground level). The distortion in the rearward pattern is even more evident than in Fig 28. This Yagi loses a bit more forward gain (0.4 dB) compared to the reference antenna. At B, elevation response comparison. The slant of the feed line causes more common-mode current due to asymmetry. In this case, placing a common-mode choke of  $+j 1000 \Omega$  at the feed point was not sufficient to eliminate the pattern distortion substantially. Another choke was required  $\lambda/4$  farther down the transmission line to eliminate common-mode currents of all varieties.**

the feed-point impedance also changes, from  $22.3 - j 25.2 \Omega$  for the reference Yagi to  $18.5 - j 29.8 \Omega$  for the antenna with the unbalanced feed. The SWR will also change with line length on the balanced Yagi fed with unbalanced line, just as it did for the simple dipole.

Clearly, the pattern of what is supposed to be a highly directional antenna can be seriously degraded by the presence of common-mode currents on the coax feed line. As in the case of the simple dipole, an odd multiple of  $\lambda/2$ -long resonant feed line to ground represents the worst-case feed system, even when the feed line is dressed symmetrically at right angles below the antenna. And as found with the dipole, the pattern deterioration becomes even worse if the feed line is dressed at a slant under the antenna to ground, although this sort of installation with a Yagi is not very common. For least interaction, the feed line still should be dressed so that it is symmetrical with respect to the antenna.

### ELIMINATING COMMON-MODE CURRENTS—THE BALUN

In the preceding sections, the problems of directional

pattern distortion and unpredictable SWR readings were traced to common-mode currents on transmission lines. Such common-mode currents arise from several types of asymmetry in the antenna-feed line system—either a mismatch between unbalanced feed line and a balanced antenna, or lack of symmetry in placement of the feed line.

A device called a *balun* can be used to eliminate these common-mode currents.

The word balun is a contraction of the words *balanced* to *unbalanced*. Its primary function is to prevent common-mode currents, while making the transition from an unbalanced transmission line to a balanced load such as an antenna. Baluns come in a variety of forms, which we will explore in this section.

### The Common-Mode Choke Balun

In the computer models used to create Figs 25, 27 and 28, placing a *common-mode choke* whose reactance is  $+j 1000 \Omega$  at the antenna's feed point removed virtually all traces of the problem. This was always true for the simple case where the feed line was dressed symmetrically, directly down under the feed point. Certain slanted-feed line lengths required additional common-mode chokes, placed at  $\lambda/4$  intervals down the transmission line from the feed point.

The simplest method to create a common-mode choke balun with coaxial cable is to wind up some of it into a coil at the feed point of the antenna. The normal transmission-line currents inside the coax are unaffected by the coiled configuration, but common-mode currents trying to flow on the outside of the coax braid are *choked off* by the reactance of the coil. This coax-coil choke could also be referred to as an "air-wound" choke, since no ferrite-core material is used to help boost the common-mode reactance at low frequencies.

A coax choke can be made like a flat coil—that is, like a coil of rope whose adjacent turns are carefully placed side-by-side to reduce inter-turn distributed capacity, rather than in a *scramble-wound* fashion. Sometimes a coil form made of PVC is used to keep things orderly. This type of choke shows a broad resonance due to its inductance and distributed capacity that can easily cover three amateur bands. See Fig 30.

Some geometries are reasonably effective over the entire HF range. If particular problems are encountered on a single band, a coil that is resonant at that band may be added. The coils shown in Table 3 were designed to have a high impedance at the indicated frequencies, as measured with an impedance meter. Many other geometries can also be effective. This construction technique is not effective with twin lead because of excessive coupling between adjacent turns.

(A)



(B)



**Fig 30—At A, an RF choke formed by coiling the feed line at the point of connection to the antenna. The inductance of the choke isolates the antenna from the remainder of the feed line. See Table 3 for winding data. At B, a bead balun consisting of 50 Amidon no. FB-73-2401 ferrite beads over a length of RG-58A coax. See text for details.**

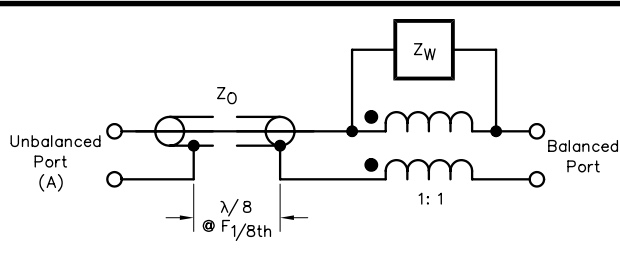
This choke-type of balun is sometimes referred to as a *current balun* since it has the hybrid properties of a tightly coupled transmission-line transformer (with a 1:1 transformation ratio) and a coil. The transmission-line transformer forces the current at the output terminals to be equal, and the coil portion chokes off common-mode currents.

See Fig 31 for a schematic representation of such a balun. This characterization is attributed to Frank Witt, A11H.  $Z_W$  is the winding impedance that chokes off common-mode currents. The winding impedance is mainly inductive if a high-frequency ferrite core is involved, while it is mainly resistive if a low-frequency ferrite core is used. The *ideal transformer* in this characterization models what happens either inside a coax or for a pair of perfectly coupled parallel wires in a two-wire transmission line. Although  $Z_W$  is shown

**Table 3**  
**Effective Choke (Current) Baluns**

Freq, MHz	Single Band (very effective)		Freq, MHz	Multiple Band
	RG-213, RG-8	RG-58		RG-8, 58, 59, 8X, 213
3.5	22 ft, 8 turns	20 ft, 6-8 turns	3.5-30	10 ft, 7 turns
7	22 ft, 10 turns	15 ft, 6 turns	3.5-10	18 ft, 9-10 turns
10	12 ft, 10 turns	10 ft, 7 turns	14-30	8 ft, 6-7 turns
14	10 ft, 4 turns	8 ft, 8 turns		
21	8 ft, 6-8 turns	6 ft, 8 turns		
28	6 ft, 6-8 turns	4 ft, 6-8 turns		

Wind the indicated length of coaxial feed line into a coil (like a coil of rope) and secure with electrical tape. The balun is most effective when the coil is near the antenna. Lengths are not highly critical.



**Fig 31—Choke balun model, also known as a 1:1 current balun. The transformer is an ideal transformer.  $Z_W$  is the common-mode winding impedance. Sources of loss are the resistive part of the winding impedance and loss in the transmission line. This model is by Frank Witt, A11H.**

here as a single impedance, it could be split into two equal parts, with one placed on each side of the ideal transformer.

### Ferrite-Core Baluns

Ferrite-core baluns can provide a high common-mode impedance over the entire HF range. They may be wound either with two conductors in bifilar fashion, or with a single coaxial cable. Rod or toroidal cores may be used, although the latter is generally preferred because greater common-mode inductance can be achieved with fewer turns. More inductance is needed for good low-frequency response, while fewer turns tends to aid high-frequency performance because less stray distributed capacity is present if the windings are spread out evenly around the circumference of the toroid.

See **Fig 32**. Common-mode impedance values of a few hundred to over a thousand ohms are readily achieved. These baluns work best when used with antennas having feed-point

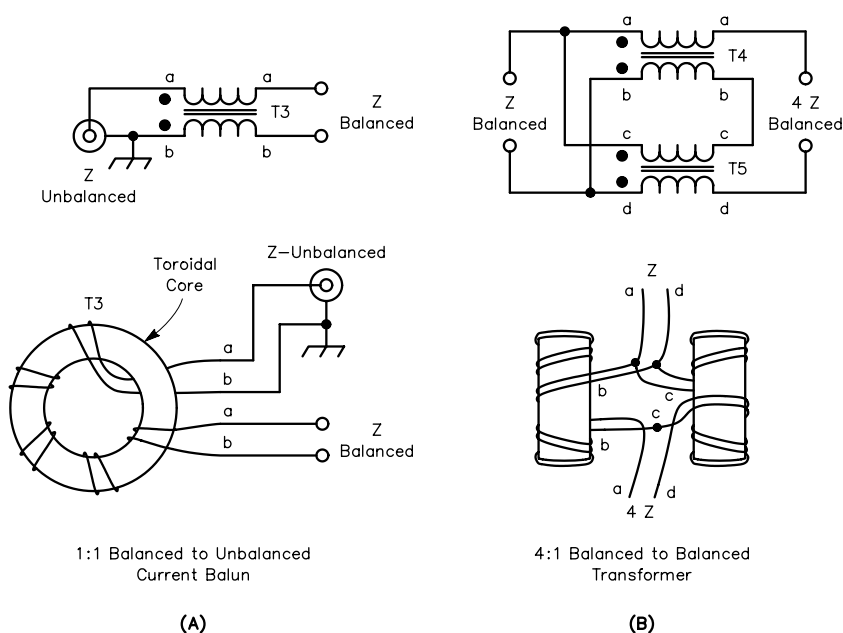
impedances less than 100  $\Omega$  or so. This is because the winding impedance must be high relative to the antenna impedance for effective operation, and higher impedances are difficult to achieve. Baluns used for high-power operation should be tested by checking for temperature rise before being put into full service. If the core overheats, especially at low frequencies, turns must be added or a larger or lower-loss core must be used. It also would be wise to investigate the cause of such high common-mode currents. Type 72, 73 or 77 ferrite will give the greatest impedance over the HF range. Type 43 ferrite has lower loss, but somewhat less permeability. Core saturation is not a problem with these ferrites at HF; they will overheat because of losses at flux levels well below saturation.

Twelve turns of #10 wire on a 2.0 or 2.5-inch OD toroidal core with  $\mu = 850$ , such as an 2.4-inch OD Type 43 core, Amidon FT240-43, are typical values for 1:1 baluns that can cover the full HF range.

### The W2DU Balun

Another type of choke balun that is very effective was originated by **M. Walter Maxwell, W2DU**. A number of small ferrite cores may be placed directly over the coax where it is connected to the antenna. The bead balun shown in **Fig 30B** consists of 50 Amidon no. FB-73-2401 ferrite beads slipped over a 1-foot length of RG-58A coax. The beads fit nicely over the insulating jacket of the coax and occupy a total length of 9 1/2 inches. Twelve Amidon FB-77-1024 or equivalent beads will come close to doing the same job using RG-8 or RG-213 coax.

Type 73 material is recommended for 1.8 to 30 MHz use, but type 77 material may be substituted; use type 43 material for 30 to 250 MHz. The cores present a high



**Fig 32—Ferrite-core baluns. Each uses transmission line techniques to achieve wide frequency coverage. The transmission line can consist of coaxial cable or tightly coupled bifilar enameled wires. Typically, twelve turns of #10 wires wound on 2.4-inch toroidal cores with  $\mu = 850$  will cover the whole range from 1.8 to 30 MHz. The 4:1 current balun at the right is wound on two cores, which are physically separated from each other.**

impedance to any RF current that would otherwise flow on the outside of the shield. The total impedance is in approximate proportion to the stacked length of the cores. Like the ferrite-core baluns described above, the impedance stays fairly constant over a wide range of frequencies. Again, 70-series ferrites are a good choice for the HF range, with type 43 being useful if heating due to large common-mode currents is a problem. Type 43 or 61 is the best choice for the VHF range. Cores of various materials can be used in combination, permitting construction of baluns effective over a very wide frequency range, such as from 2 to 250 MHz.

### Detuning Sleeves

The detuning sleeve shown in **Fig 33B** is essentially an air-insulated  $\lambda/4$  line, but of the coaxial type, with the sleeve constituting the outer conductor and the outside of the coax line being the inner conductor. Because the impedance at the open end is very high, the unbalanced voltage on the coax line cannot cause much current to flow on the outside of the sleeve. Thus the sleeve acts just like a choke coil to isolate the remainder of the line from the antenna. (The same viewpoint can be used in explaining the action of the  $\lambda/4$  arrangement shown at Fig 33A, but is less

easy to understand in the case of baluns less than  $\lambda/4$  long.)

A sleeve of this type may be resonated by cutting a small longitudinal slot near the bottom, just large enough to take a single-turn loop which is, in turn, link-coupled to a dip meter. If the sleeve is a little long to start with, a bit at a time can be cut off the top until the stub is resonant.

The diameter of the coaxial detuning sleeve in Fig 33B should be fairly large compared with the diameter of the cable it surrounds. A diameter of two inches or so is satisfactory with half-inch cable. The sleeve should be symmetrically placed with respect to the center of the antenna so that it will be equally coupled to both sides. Otherwise a current will be induced from the antenna to the outside of the sleeve. This is particularly important at VHF and UHF.

In both the balancing methods shown in Fig 33 the  $\lambda/4$  section should be cut to be resonant at exactly the same frequency as the antenna itself. These sections tend to have a beneficial effect on the impedance-frequency characteristic of the system, because their reactance varies in the opposite direction to that of the antenna. For instance, if the operating frequency is slightly below resonance the antenna has capacitive reactance, but the shorted  $\lambda/4$  sections or stubs have inductive reactance. Thus the reactances tend to cancel, which prevents the impedance from changing rapidly and helps maintain a low SWR on the line over a band of frequencies.

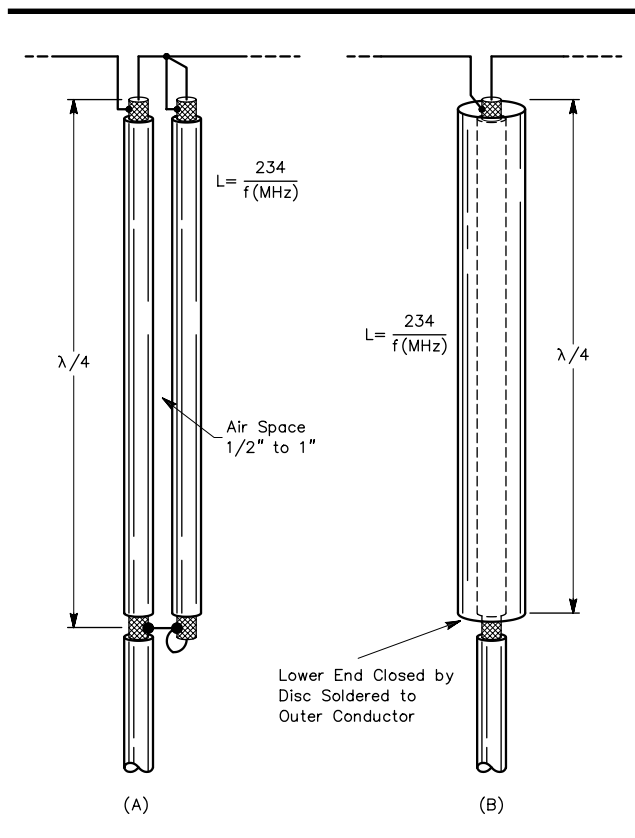
### Combined Balun and Matching Stub

In certain antenna systems the balun length can be considerably shorter than  $\lambda/4$ ; the balun is, in fact, used as part of the matching system. This requires that the radiation resistance be fairly low as compared with the line  $Z_0$  so that a match can be brought about by first shortening the antenna to make it have a capacitive reactance, and then using a shunt inductor across the antenna terminals to resonate the antenna and simultaneously raise the impedance to a value equal to the line  $Z_0$ . This is the same principle used for hairpin matches. The balun is then made the proper length to exhibit the desired value of inductive reactance.

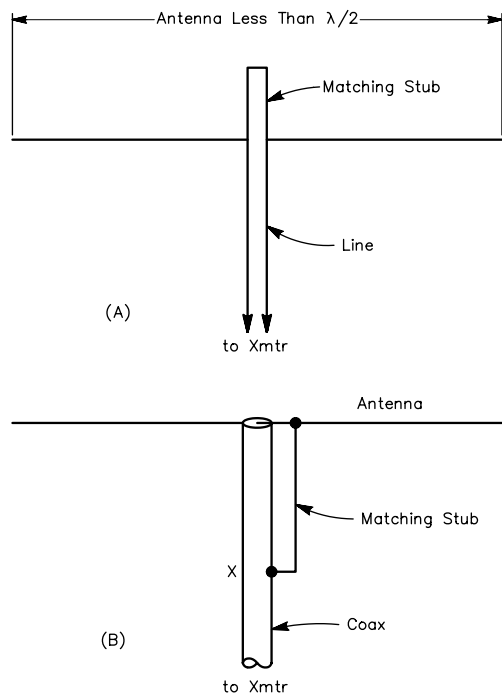
The basic matching method is shown in **Fig 34A**, and the balun adaptation to coaxial feed is shown in Fig 34B. The matching stub in Fig 34B is a parallel-line section, one conductor of which is the outside of the coax between point X and the antenna; the other stub conductor is an equal length of wire. (A piece of coax may be used instead, as in the balun in Fig 33A.) The spacing between the stub conductors can be 2 to 3 inches. The stub of Fig 34 is ordinarily much shorter than  $\lambda/4$ , and the impedance match can be adjusted by altering the stub length along with the antenna length. With simple coax feed, even with a  $\lambda/4$  balun as in Fig 33, the match depends entirely on the actual antenna impedance and the  $Z_0$  of the cable; no adjustment is possible.

### Adjustment

When a  $\lambda/4$  balun is used it is advisable to resonate it before connecting the antenna. This can be done without much difficulty if a dip meter or impedance analyzer is



**Fig 33—Fixed-balun methods for balancing the termination when a coaxial cable is connected to a balanced antenna. These baluns work at a single frequency. The balun at B is known as a “sleeve balun” and is often found at VHF.**



**Fig 34—Combined matching stub and balun. The basic arrangement is shown at A. At B, the balun arrangement is achieved by using a section of the outside of the coax feed line as one conductor of a matching stub.**

available. In the system shown in Fig 33A, the section formed by the two parallel pieces of line should first be made slightly longer than the length given by the equation. The shorting connection at the bottom may be installed permanently. With the dip meter coupled to the shorted end, check the frequency and cut off small lengths of the shield braid (cutting both lines equally) at the open ends until the stub is resonant at the desired frequency. In each case leave just enough inner conductor remaining to make a short connection to the antenna. After resonance has been established, solder the inner and outer conductors of the second piece of coax together and complete the connections indicated in Fig 33A.

Another method is to first adjust the antenna length to the desired frequency, with the line and stub disconnected, then connect the balun and recheck the frequency. Its length may then be adjusted so that the overall system is again resonant at the desired frequency.

### Construction

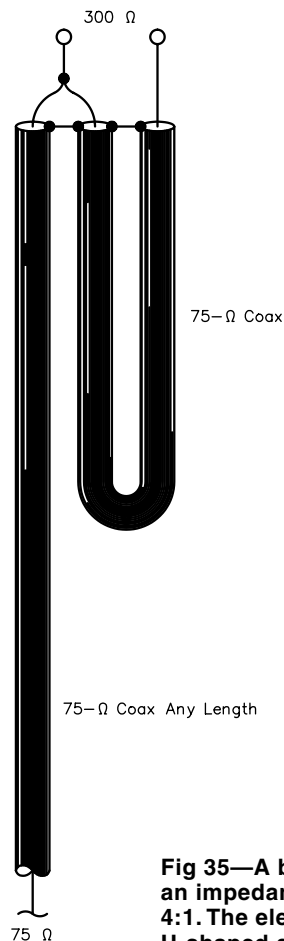
In constructing a balun of the type shown in Fig 33A, the additional conductor and the line should be maintained parallel by suitable spacers. It is convenient to use a piece of coax for the second conductor; the inner conductor can simply be soldered to the outer conductor at both ends since it does not enter into the operation of the device. The two cables should be separated sufficiently so that the vinyl covering represents only a small proportion of the dielectric

between them. Since the principal dielectric is air, the length of the  $\lambda/4$  section is based on a velocity factor of 0.95, approximately.

### Impedance Step-Up/Step-Down Balun

A coax-line balun may also be constructed to give an impedance step-up ratio of 4:1. This form of balun is shown in Fig 35. If 75- $\Omega$  line is used, as indicated, the balun will provide a match for a 300- $\Omega$  terminating impedance. If 50- $\Omega$  line is used, the balun will provide a match for a 200- $\Omega$  terminating impedance. The U-shaped section of line must be an electrical length of  $\lambda/2$  long, taking the velocity factor of the line into account. In most installations using this type of balun, it is customary to roll up the length of line represented by the U-shaped section into a coil of several inches in diameter. The coil turns may be bound together with electrical tape.

Because of the bulk and weight of the balun, this type is seldom used with wire-line antennas suspended by insulators at the antenna ends. More commonly it is used with multielement Yagi antennas, where its weight may be supported by the boom of the antenna system. See the K1FO designs in Chapter 18, where 200- $\Omega$  T-matches are used with such a balun.



**Fig 35—A balun that provides an impedance step-up ratio of 4:1. The electrical length of the U-shaped section of line is  $\lambda/2$ .**

## ONE FINAL WORD

This is a good point to debunk a persistent myth among amateurs that a mismatched transmission line somehow radiates. This is absolutely not true! The loss by radiation from a properly balanced line—whether coax or open-wire line—is miniscule. Whenever a line radiates it is because of an unbalanced condition somewhere in the system (on the antenna or its environment or on the line itself) or because of common-mode currents radiated by the antenna back onto the line because of asymmetry in the system. The SWR on the line has nothing to do with unwanted radiation from a transmission line.

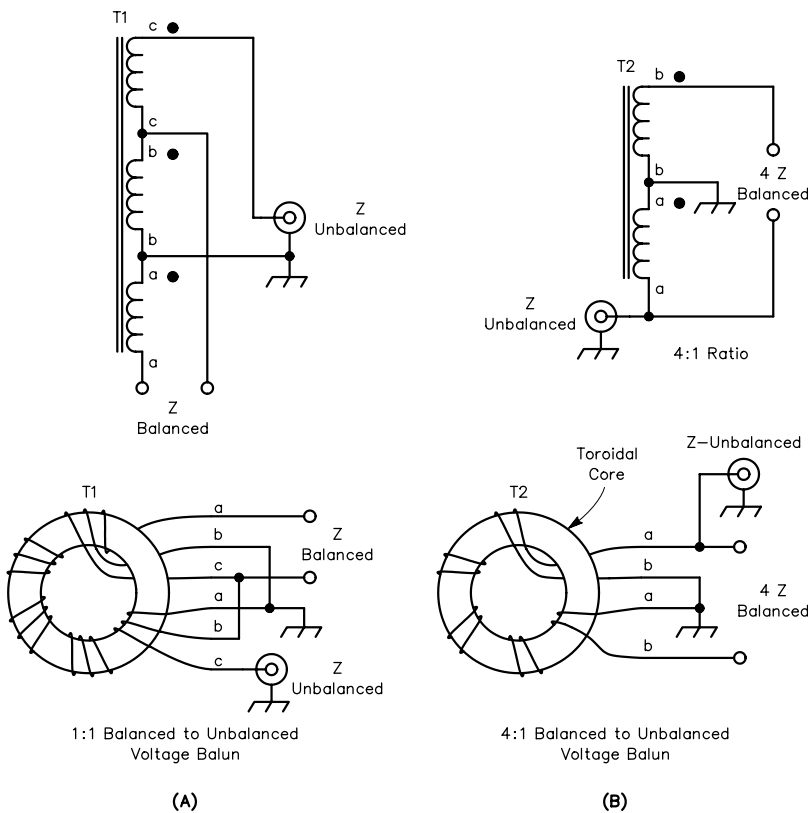
## BIBLIOGRAPHY

Source material and more extended discussions of topics covered in this chapter can be found in the references given below and in the textbooks listed at the end of [Chapter 2](#).

- B. A. Eggers, "An Analysis of the Balun," *QST*, Apr 1980, pp 19-21.  
 D. Geiser, "Resistive Impedance Matching with Quarter-Wave Lines," *QST*, Feb 1963, pp 63-67.  
 J. D. Gooch, O. E. Gardner, and G. L. Roberts, "The Hairpin Match," *QST*,

Apr 1962, pp 11-14, 146, 156.

- G. Grammer, "Simplified Design of Impedance-Matching Networks," in three parts, *QST*, Mar, Apr and May 1957.  
 D. J. Healey, "An Examination of the Gamma Match," *QST*, Apr 1969, pp 11-15, 57.  
 J. D. Kraus and S. S. Sturgeon, "The T-Matched Antenna," *QST*, Sep 1940, pp 24-25.  
 R. W. Lewallen, "Baluns: What They Do and How They Do It," *The ARRL Antenna Compendium Vol 1* (Newington: ARRL, 1985), pp 157-164.  
 M. W. Maxwell, "Some Aspects of the Balun Problem," Mar 1983, *QST*, pp 38-40.  
 M. W. Maxwell, *Reflections, Transmission Lines and Antennas* (Newington: ARRL, 1990).  
 R. A. Nelson, "Basic Gamma Matching," *Ham Radio*, Jan 1985, pp 29-31, 33.  
 F. A. Regier, "Series-Section Transmission-Line Impedance Matching," *QST*, Jul 1978, pp 14-16.  
 J. Sevick, "Simple Broadband Matching Networks," *QST*, Jan 1976, pp 20-23.  
 R. E. Stephens, "Admittance Matching the Ground-Plane Antenna to Coaxial Transmission Line," Technical Correspondence, *QST*, Apr 1973, pp 55-57.  
 H. F. Tolles, "How to Design Gamma-Matching Networks," *Ham Radio*, May 1973, pp 46-55.  
 F. Witt, "Baluns in the Real (and Complex) World," *The ARRL Antenna Compendium Vol 5* (Newington: ARRL, 1997), pp 171-181.



**Fig 36—Voltage-type baluns. These have largely been supplanted by the current or choke type of balun.**

### Voltage Baluns

The voltage baluns shown in [Fig 36A](#) and [Fig 36B](#), cause equal and opposite voltages to appear at the two output terminals, relative to the voltage at the cold side of the input. If the two antenna halves are perfectly balanced with respect to ground, the currents flowing from the output terminals will be equal and opposite and no common-mode current will flow on the line. This means that, if the line is coaxial, there will be no current flowing on the outside of the shield; if the line is balanced, the currents in the two conductors will be equal and opposite. These are the conditions for a nonradiating line.

Under this condition, the 1:1 voltage balun of [Fig 36A](#) performs exactly the same function as the current balun of [Fig 32A](#), as there is no current in winding b. If the antenna isn't perfectly symmetrical, however, unequal currents will appear at the balun output, causing antenna current to flow on the line, an undesirable condition. Another potential shortcoming of the 1:1 voltage balun is that winding b appears across the line. If this winding has insufficient impedance (a common problem, particularly near the lower frequency end of its range), the system SWR will be degraded.

The 1:1 choke or current balun in [Fig 32A](#) is recommended for use at the junction of the antenna and feed line. However, voltage baluns still are commonly used in this application and may serve a useful function if the user is aware of their shortcomings.



# Chapter 27

# Antenna and Transmission-Line Measurements

The principal quantities measured on transmission lines are line current or voltage, and standing-wave ratio (SWR). You make measurements of current or voltage to determine the power input to the line. SWR measurements are useful in connection with the design of coupling circuits and the adjustment of the match between the antenna and transmission line, as well as in the adjustment of these matching circuits.

For most practical purposes a relative measurement is sufficient. An uncalibrated indicator that shows when the largest possible amount of power is being put into the line is just as useful, in most cases, as an instrument that measures the power accurately. It is seldom necessary to know the actual number of watts going into the line unless the overall efficiency of the system is being investigated. An instrument that shows when the SWR is close to 1:1 is all you need for most impedance-matching adjustments. Accurate measurement of SWR is necessary only in studies of antenna characteristics such as bandwidth, or for the design of some types of matching systems, such as a stub match.

Quantitative measurements of reasonable accuracy demand good design and careful construction in the measuring instruments. They also require intelligent use of the equipment, including a knowledge not only of its limitations but also of stray effects that often lead to false results. Until you know the complete conditions of the measurements, a certain amount of skepticism regarding numerical data resulting from amateur measurements with simple equipment is justified. On the other hand, purely qualitative or relative measurements are easy to make and are reliable for the purposes mentioned above.

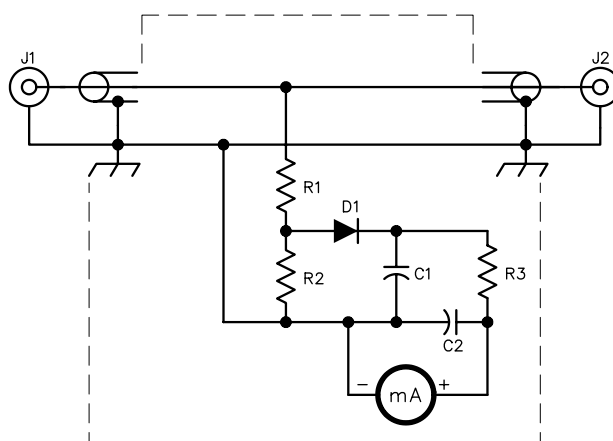
## LINE CURRENT AND VOLTAGE

A current or voltage indicator that can be used with coaxial line is a useful piece of equipment. It need not be elaborate or expensive. Its principal function is to show when the maximum power is being taken from the transmitter; for any given set of line conditions (length, SWR, etc). This will occur when you adjust the transmitter coupling for maximum current or voltage into the transmission line. Although the final-amplifier plate or collector current meter is frequently used for this purpose, it is not always a reliable

indicator. In many cases, particularly with a screen-grid tube in the final stage, minimum loaded plate current does not occur simultaneously with maximum power output.

## RF VOLTMETER

You can put together a germanium diode in conjunction with a low-range milliammeter and a few resistors to form an RF voltmeter suitable for connecting across the two conductors of a coaxial line, as shown in **Fig 1**. It consists of a voltage divider, R1-R2, having a total resistance about 100 times the  $Z_0$  of the line (so the power consumed will be negligible) with a diode rectifier and milliammeter connected across part of the divider to read relative RF voltage. The purpose of R3 is to make the meter readings directly proportional to the applied voltage, as nearly as possible, by swamping the resistance of D1, since the diode resistance will vary with the amplitude of the current through the diode.



**Fig 1—RF voltmeter for coaxial line.**

**C1, C2—0.005- or 0.01- $\mu$ F ceramic.**

**D1—Germanium diode, 1N34A.**

**J1, J2—Coaxial fittings, chassis-mounting type.**

**M1—0-1 milliammeter (more sensitive meter may be used if desired; see text).**

**R1—6.8 k $\Omega$ , composition, 1 W for each 100 W of RF power.**

**R2—680  $\Omega$ , 1/2 or 1 W composition.**

**R3—10 k $\Omega$ , 1/2 W (see text).**

You may construct the voltmeter in a small metal box, indicated by the dashed line in the drawing, and fitted with coax receptacles. R1 and R2 should be carbon-composition resistors. The power rating for R1 should be 1 W for each 100 W of carrier power in the matched line; separate 1- or 2-W resistors should be used to make up the total power rating required, to the total resistance as given. Any type of resistor can be used for R3; the total resistance should be such that about 10 V dc will be developed across it at full scale. For example, a 0-1 milliammeter would require 10 k $\Omega$ , a 0-500 microammeter would take 20 k $\Omega$ , and so on. For comparative measurements only, R3 may be a variable resistor so the sensitivity can be adjusted for various power levels.

In constructing such a voltmeter, you should exercise care to prevent inductive coupling between R1 and the loop formed by R2, D1 and C1, and between the same loop and the line conductors in the assembly. With the lower end of R1 disconnected from R2 and grounded to the enclosure, but without changing its position with respect to the loop, there should be no meter indication when full power is going through the line.

If more than one resistor is used for R1, the units should be arranged end-to-end with very short leads. R1 and R2 should be kept 1/2 inch or more from metal surfaces parallel to the body of the resistor. If you observe these precautions the voltmeter will give consistent readings at frequencies up to 30 MHz. Stray capacitance and stray coupling limit the accuracy at higher frequencies but do not affect the utility of the instrument for comparative measurements.

### Calibration

You may calibrate the meter for RF voltage by comparison with a standard such as an RF ammeter. This requires that the line be well matched so the impedance at the point of measurement is equal to the actual  $Z_0$  of the line. Since in that case  $P = I^2 Z_0$ , the power can be calculated from the current. Then  $E = \sqrt{PZ_0}$ . By making current and voltage measurements at a number of different power levels, you can obtain enough points to draw a calibration curve for your particular setup.

### RF AMMETERS

Although they are not as widely available as they used to be, if you can find one on the surplus market or at a hamfest, an RF ammeter is a good way to gauge output power. You can mount an RF ammeter in any convenient location at the input end of the transmission line, the principal



**Fig 2—A convenient method of mounting an RF ammeter for use in a coaxial line. This is a metal-case instrument mounted on a thin bakelite panel. The cutout in the metal clears the edge of the meter by about 1/8 inch.**

precaution being that the capacitance to ground, chassis, and nearby conductors should be low. A bakelite-case instrument can be mounted on a metal panel without introducing enough shunt capacitance to ground to cause serious error up to 30 MHz. When installing a metal-case instrument on a metal panel, you should mount it on a separate sheet of insulating material so that there is 1/8 inch or more separation between the edge of the case and the metal.

A 2-inch instrument can be mounted in a 2 x 4 x 4-inch metal box, as shown in **Fig 2**. This is a convenient arrangement for use with coaxial line. Installed this way, a good quality RF ammeter will measure current with an accuracy that is entirely adequate for calculating power in the line. As discussed above in connection with calibrating RF voltmeters, the line must be closely matched by its load so the actual impedance is resistive and equal to  $Z_0$ . The scales of such instruments are cramped at the low end, however, which limits the range of power that can be measured by a single meter. The useful current range is about 3 to 1, corresponding to a power range of about 9 to 1.

## SWR Measurements

On parallel-conductor lines it is possible to measure the standing-wave ratio by moving a current (or voltage) indicator along the line, noting the maximum and minimum values of current (or voltage) and then computing the SWR from these measured values. This

cannot be done with coaxial line since it is not possible to make measurements of this type inside the cable. The technique is, in fact, seldom used with open lines because it is not only inconvenient but sometimes impossible to reach all parts of the line conductors. Also, the method is

subject to considerable error from antenna currents flowing on the line.

Present-day SWR measurements made by amateurs practically always use some form of *directional coupler* or RF-bridge circuit. The indicator circuits themselves are fundamentally simple, but they require considerable care in construction to ensure accurate measurements. The requirements for indicators used only for the adjustment of impedance-matching circuits, rather than actual SWR measurement, are not so stringent, and you can easily make an instrument for this purpose.

### BRIDGE CIRCUITS

Two commonly used bridge circuits are shown in Fig 3. The bridges consist essentially of two voltage dividers in parallel, with a voltmeter connected between the junctions of each pair of *arms*, as the individual elements are called. When the equations shown to the right of each circuit are satisfied there is no potential difference between the two junctions, and the voltmeter indicates zero voltage. The bridge is then said to be in *balance*.

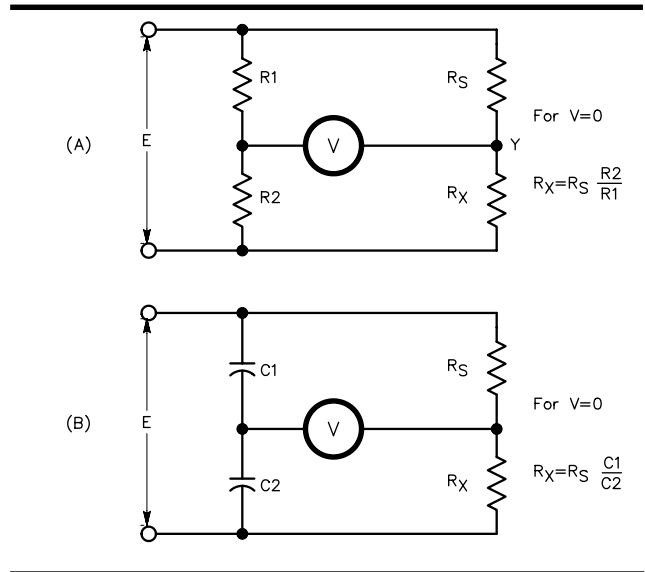
Taking Fig 3A as an illustration, if  $R_1 = R_2$ , half the applied voltage,  $E$ , will appear across each resistor. Then if  $R_S = R_X$ ,  $\frac{1}{2}E$  will appear across each of these resistors and the voltmeter reading will be zero. Remember that a matched transmission line has essentially a purely resistive input impedance. Suppose that the input terminals of such a line are substituted for  $R_X$ . Then if  $R_S$  is a resistor equal to the  $Z_0$  of the line, the bridge will be balanced.

If the line is not perfectly matched, its input impedance will not equal  $Z_0$  and hence will not equal  $R_S$ , since you chose the latter to be equal to  $Z_0$ . There will then be a difference in potential between points X and Y, and the voltmeter will show a reading. Such a bridge therefore can be used to show the presence of standing waves on the line, because the line input impedance will be equal to  $Z_0$  only when there are no standing waves.

Considering the nature of the incident and reflected components of voltage that make up the actual voltage at the input terminals of the line, as discussed in Chapter 24, it should be clear that when  $R_S = Z_0$ , the bridge is always in balance for the incident component. Thus the voltmeter does not respond to the incident component at any time but reads only the reflected component (assuming that  $R_2$  is very small compared with the voltmeter impedance). The incident component can be measured across either  $R_1$  or  $R_2$ , if they are equal resistances. The standing-wave ratio is then

$$SWR = \frac{E_1 + E_2}{E_1 - E_2} \quad (\text{Eq 1})$$

where  $E_1$  is the incident voltage and  $E_2$  is the reflected voltage. It is often simpler to normalize the voltages by expressing  $E_2$  as a fraction of  $E_1$ , in which case the formula becomes



**Fig 3—Bridge circuits suitable for SWR measurement. At A, Wheatstone type using resistance arms. At B, capacitance-resistance bridge (“Micromatch”). Conditions for balance are independent of frequency in both types.**

$$SWR = \frac{1+k}{1-k} \quad (\text{Eq 2})$$

where  $k = E_2/E_1$ .

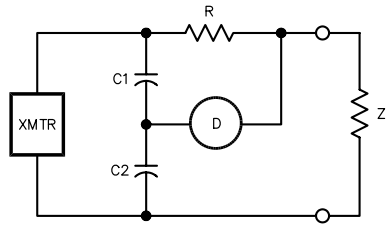
The operation of the circuit in Fig 3B is essentially the same, although this circuit has arms containing reactance as well as resistance.

It is not necessary that  $R_1 = R_2$  in Fig 3A; the bridge can be balanced, in theory, with any ratio of these two resistances provided  $R_S$  is changed accordingly. In practice, however, the accuracy is highest when the two are equal; this circuit is most commonly used.

A number of types of bridge circuits appear in Fig 4, many of which have been used in amateur products or amateur construction projects. All except that at G can have the generator and load at a common potential. At G, the generator and detector are at a common potential. You may interchange the positions of the detector and transmitter (or generator) in the bridge, and this may be advantageous in some applications.

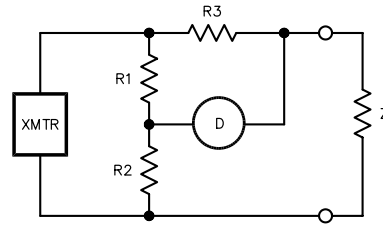
The bridges shown at D, E, F and H may have one terminal of the generator, detector and load common. Bridges at A, B, E, F, G and H have constant sensitivity over a wide frequency range. Bridges at B, C, D and H may be designed to show no discontinuity (impedance lump) with a matched line, as shown in the drawing. Discontinuities with A, E and F may be small.

Bridges are usually most sensitive when the detector bridges the midpoint of the generator voltage, as in G or H, or in B when each resistor equals the load impedance. Sensitivity also increases when the currents in each leg are equal.



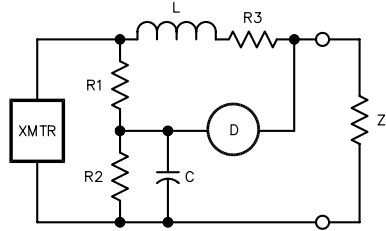
De Sauty/Wein (Micromatch)  
(A)

$$\text{Balance } Z = \frac{RC1}{C2}$$



Christie/Wheatstone (Antenna-Scope)  
(B)

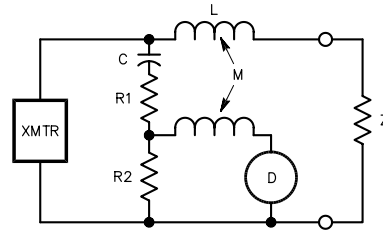
$$\text{Balance } Z = \frac{R2R3}{R1}$$



Maxwell (Universal)  
(C)

$$\text{Balance } R1Z = R2R3 = L/C$$

No Discontinuity:  $R2 \rightarrow \infty$ ,  
 $R3 \rightarrow 0$ ,  $R1 = Z$

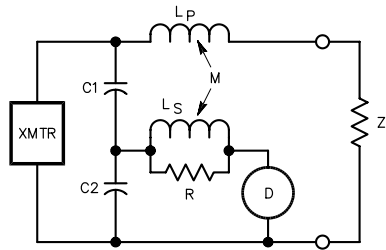


Carey-Foster  
(Twin-Lamp, Monomatch Mickey-Match)  
(D)

$$\text{Balance } M = CR2Z$$

$$L = M(1 + R1/R2)$$

No Discontinuity:  $R1 + R2 = Z = \sqrt{L/C}$



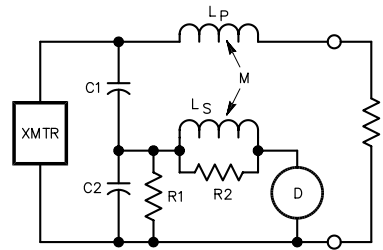
Bruene (Collins Radio)  
(E)

$$\text{Balance (Approx.) } Z C1 Ls = MR(C1 + C2)$$

$$(2\pi f Ls \gg R)$$

$$(Lp = M \text{ Approx})$$

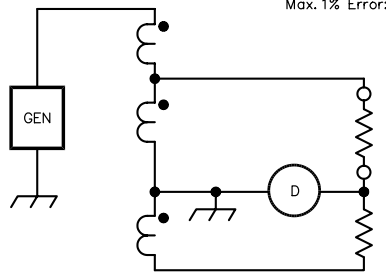
$$\text{Max. 1\% Error: } 2\pi f Ls \geq 7R$$



Phase-Compensated  
(F)

$$\text{Balance: } Z R1 C1 = M = Lp$$

$$Ls = R1 R2 (C1 + C2)$$

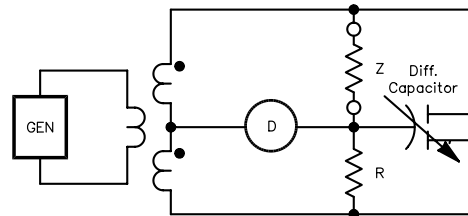


(G)

Starr's "Hybrid Coil"

$$\text{Balance: } R = Z$$

(The Differential Capacitor Can Balance Parallel Reactance.)



(H)

**Fig 4—Various types of SWR indicator circuits and commonly known names of bridge circuits or devices in that they have been used. Detectors (D) are usually semiconductor diodes with meters, isolated with RF chokes and capacitors. However, the detector may be a radio receiver. In each circuit, Z represents the load being measured. (This information provided by David Geiser, WA2ANU)**

# Resistance Bridge

The basic bridge configuration shown in Fig 3B may be home constructed and is reasonably accurate for SWR measurement. A practical circuit for such a bridge is given in Fig 5 and a representative layout is shown in Fig 6. Properly built, a bridge of this design can be used for measurement of SWRs up to about 15:1 with good accuracy.

You should observe these important construction points:

- 1) Keep leads in the RF circuit short, to reduce stray inductance.
- 2) Mount resistors two or three times their body diameter away from metal parts, to reduce stray capacitance.
- 3) Place the RF components so there is as little inductive and capacitive coupling as possible between the bridge arms.

In the instrument shown in Fig 6, the input and line connectors, J1 and J2, are mounted fairly close together so the standard resistor,  $R_S$ , can be supported with short leads directly between the center terminals of the connectors. R2 is mounted at right angles to  $R_S$ , and a shield partition is used between these two components and the others.

The two 47-k $\Omega$  resistors, R5 and R6 in Fig 5, are voltmeter multipliers for the 0-100 microammeter used as an indicator. This is sufficient resistance to make the voltmeter linear (that is, the meter reading is directly

proportional to the RF voltage) and no voltage calibration curve is needed. D1 is the rectifier for the reflected voltage and D2 is for the incident voltage. Because of manufacturing variations in resistors and diodes, the readings may differ slightly with two multipliers of the same nominal resistance value, so a correction resistor, R3, is included in the circuit. You should select its value so that the meter reading is the same with S1 in either position, when RF is applied to the bridge with the line connection open. In the instrument shown, a value of 1000  $\Omega$  was required in series with the multiplier for reflected voltage; in other cases different values probably would be needed and R3 might have to be put in series with the multiplier for the incident voltage. You can determine this by experiment.

The value used for R1 and R2 is not critical, but you should match the two resistors within 1% or 2% if possible. Keep the resistance of  $R_S$  as close as possible to the actual  $Z_0$  of the line you use (generally 50 or 75  $\Omega$ ). Select the resistor by actual measurement with an accurate resistance bridge, if you have one available.

R4 is for adjusting the incident-voltage reading to full scale in the measurement procedure described below. Its use is not essential, but it offers a convenient alternative to exact adjustment of the RF input voltage.

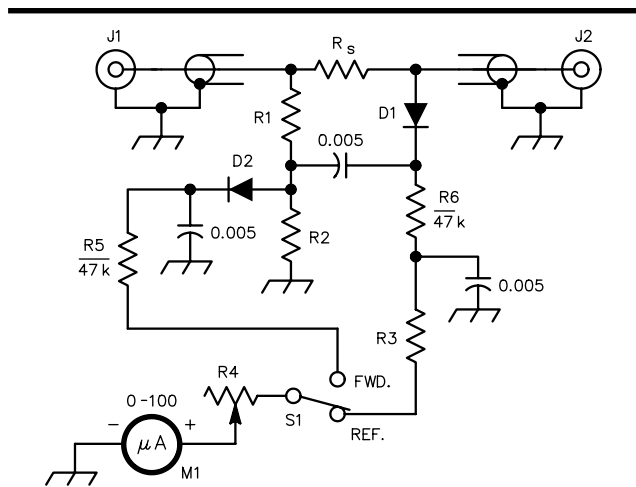
## Testing

Measure R1, R2 and  $R_S$  with a reliable digital ohmmeter or resistance bridge after completing the wiring. This will ensure that their values have not changed from the heat of soldering. Disconnect one side of the microammeter and leave the input and output terminals of the unit open during such measurements to avoid stray shunt paths through the rectifiers.

Check the two voltmeter circuits as described above, applying enough RF (about 10 V) to the input terminals to give a full-scale reading with the line terminals open. If necessary, try different values for R3 until the reading is the same with S1 in either position.

With J2 open, adjust the RF input voltage and R4 for full-scale reading with S1 in the incident-voltage position. Then switch S1 to the reflected-voltage position. The reading should remain at full scale. Next, short-circuit J2 by touching a screwdriver between the center terminal and the frame of the connector to make a low-inductance short. Switch S1 to the incident-voltage position and readjust R4 for full scale, if necessary. Then throw S1 to the reflected-voltage position, keeping J2 shorted, and the reading should be full scale as before. If the readings differ, R1 and R2 are not the same value, or there is stray coupling between the arms of the bridge. You must read the reflected voltage at full scale with J2 either open or shorted, when the incident voltage is set to full scale in each case, to make accurate SWR measurements.

The circuit should pass these tests at all frequencies at which it is to be used. It is sufficient to test at the lowest and highest frequencies, usually 1.8 or 3.5 and 28 or 50 MHz.



**Fig 5—Resistance bridge for SWR measurement. Capacitors are disc ceramic. Resistors are 1/2-watt composition except as noted below.**

**D1, D2—Germanium diode, high back resistance type (1N34A, 1N270, etc).**

**J1, J2—Coaxial connectors, chassis-mounting type.**

**M1—0-100 dc microammeter.**

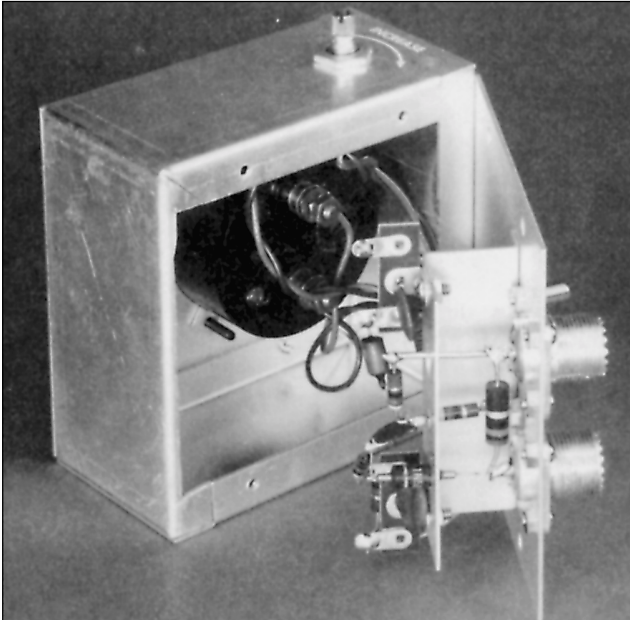
**R1, R2—47  $\Omega$ , 1/2-W composition (see text).**

**R3—See text.**

**R4—50-k $\Omega$  volume control.**

**$R_S$ —Resistance equal to line  $Z_0$  (1/2 or 1 W composition).**

**S1—SPDT toggle.**



**Fig 6**—A 2 × 4 × 4-inch aluminum box is used to house this SWR bridge, which uses the circuit of Fig 5. The variable resistor, R4, is mounted on the side. The bridge components are mounted on one side plate of the box and a subchassis formed from a piece of aluminum. The input connector is at the top in this view. R<sub>s</sub> is connected directly between the two center posts of the connectors. R2 is visible behind it and perpendicular to it. One terminal of D1 projects through a hole in the chassis so the lead can be connected to J2. R1 is mounted vertically to the left of the chassis in this view, with D2 connected between the junction of R1-R2 and a tie point.

If R1 and R2 are poorly matched but the bridge construction is otherwise good, discrepancies in the readings will be substantially the same at all frequencies. A difference in behavior at the low and high ends of the frequency range can be attributed to stray coupling between bridge arms, or stray inductance or capacitance in the arms.

To check the bridge for balance, apply RF and adjust R4 for full scale with J2 open. Then connect a resistor identical with R<sub>s</sub> (the resistance should match within 1% or 2%) to the line terminals, using the shortest possible leads. It is convenient to mount the test resistor inside a cable connector (PL-259), a method of mounting that also minimizes lead inductance. When you connect the test resistor the reflected-voltage reading should drop to zero. The incident voltage should be reset to full scale by means of R4, if necessary. The reflected reading should be zero at any frequency in the range to be used. If a good null is obtained at low frequencies but some residual current shows at the high end, the trouble may be the inductance of the test resistor leads, although it may also be caused by stray coupling between the arms of the bridge itself.

If there is a constant low (but not zero) reading at all

frequencies the problem is poor matching of the resistance values. Both effects can be present simultaneously. You should make sure you obtain a good null at all frequencies before using your bridge.

### Bridge Operation

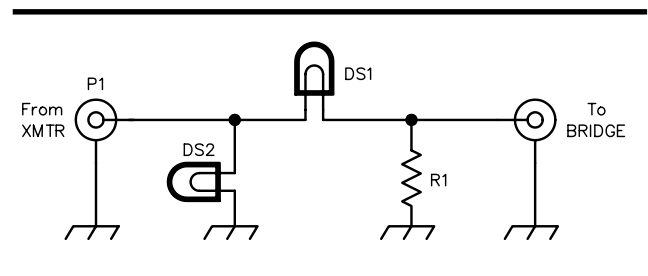
You must limit the RF power input to a bridge of this type to a few watts at most, because of the power-dissipation ratings of the resistors. If the transmitter has no provision for reducing power output to a very low value—less than 5 W—a simple power-absorber circuit can be made up, as shown in Fig 7. Lamp DS1 tends to maintain constant current through the resistor over a fairly wide power range, so the voltage drop across the resistor also tends to be constant. This voltage is applied to the bridge, and with the constants given is in the right range for resistance-type bridges.

To make a measurement, connect the unknown load to J2 and apply sufficient RF voltage to J1 to give a full-scale incident-voltage reading. Use R4 to set the indicator to exactly full scale. Then throw S1 to the reflected voltage position and note the meter reading. The SWR is then found by using these readings in Eq 1.

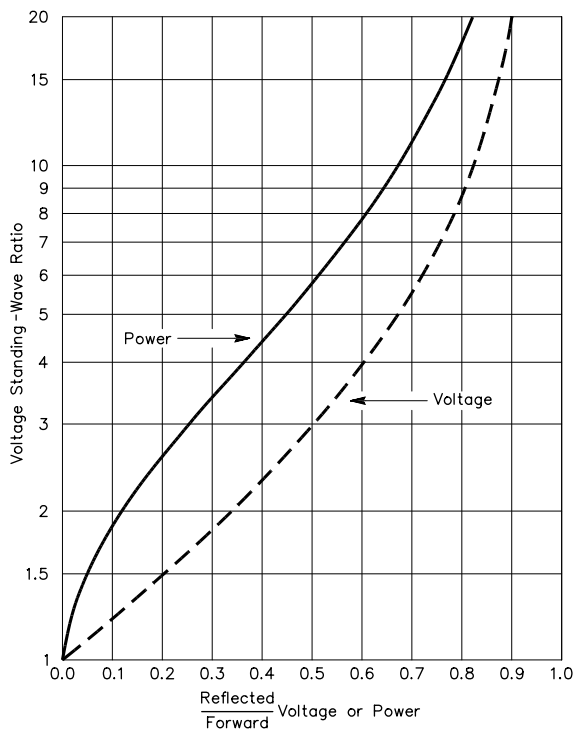
For example, if the full-scale calibration of the dc instrument is 100 μA and the reading with S2 in the reflected-voltage position is 40 μA, the SWR is

$$\text{SWR} = \frac{100 + 40}{100 - 40} = \frac{140}{60} = 2.33:1$$

Instead of calculating the SWR value, you could use the voltage curve in Fig 8. In this example the ratio of reflected to forward voltage is 40/100 = 0.4, and from Fig 8 the SWR value is about 2.3:1.



**Fig 7**—Power-absorber circuit for use with resistance-type SWR bridges when the transmitter has no special provisions for power reduction. For RF powers up to 50 W, DS1 is a 117-V 40-W incandescent lamp and DS2 is not used. For higher powers, use sufficient additional lamp capacity at DS2 to load the transmitter to about normal output; for example, for 250 W output DS2 may consist of two 100-W lamps in parallel. R1 is made from three 1-W 68-Ω resistors connected in parallel. P1 and P2 are cable-mounting coaxial connectors. Leads in the circuit formed by the lamps and R1 should be kept short, but convenient lengths of cable may be used between this assembly and the connectors.



**Fig 8—Chart for finding voltage standing-wave ratio when the ratio of reflected-to-forward voltage or reflected-to-forward power is known.**

You may calibrate the meter scale in any arbitrary units, so long as the scale has equal divisions. It is the ratios of the voltages, and not the actual values, that determine the SWR.

### AVOIDING ERRORS IN SWR MEASUREMENTS

The principal causes of inaccuracies within the bridge are differences in the resistances of R1 and R2, stray inductance and capacitance in the bridge arms, and stray coupling between arms. If the checkout procedure described above is followed carefully, the bridge in Fig 5 should be amply accurate for practical use. The accuracy is highest for low standing-wave ratios because of the nature of the SWR calculation; at high ratios the divisor in the equation above represents the difference between two nearly equal quantities, so a small error in voltage measurement may mean a considerable difference in the calculated SWR.

The standard resistor  $R_S$  must equal the actual  $Z_0$  of the line. The actual  $Z_0$  of a sample of line may differ by a few percent from the nominal figure because of manufacturing variations, but this has to be tolerated. In the 50- to 75- $\Omega$  range, the RF resistance of a composition resistor of 1/2- or 1-W rating is essentially identical with its dc resistance.

### Common-Mode Currents

As explained in Chapter 26, there are two ways in which unwanted *common-mode* (sometimes called *antenna*) currents can flow on the outside of a coaxial line—currents

radiated onto the line because of its spatial relationship to the antenna and currents that result from the direct connection between the coax outer conductor and (usually) one side of the antenna. The radiated current usually will not be troublesome if the bridge and the transmitter (or other source of RF power for operating the bridge) are shielded so that any RF currents flowing on the outside of the line cannot find their way into the bridge. This point can be checked by inserting an additional section of line ( $1/8$  to  $1/4$  electrical wavelength preferably) of the same  $Z_0$ . The SWR indicated by the bridge should not change except for a slight decrease because of the additional line loss. If there is a marked change, you may need better shielding.

Parallel-type currents caused by the connection to the antenna without using a common-mode choke balun will change the SWR with variations in line length, even though the bridge and transmitter are well-shielded and the shielding is maintained throughout the system by the use of coaxial fittings. Often, merely moving the transmission line around will cause the indicated SWR to change. This is because the outside of the coax becomes part of the antenna system—being connected to the antenna at the feed point. The outside shield of the line thus constitutes a load, along with the desired load represented by the antenna itself. The SWR on the line then is determined by the composite load of the antenna and the outside of the coax. Since changing the line length (or position) changes one component of this composite load, the SWR changes too.

The remedy for such a situation is to use a good balun or to detune the outside of the line by proper choice of length. Note that this is not a *measurement error*, since what the instrument reads is the actual SWR on the line. However, it is an undesirable condition since the line is usually operating at a higher SWR than it should—and would—if the parallel-type current on the outside of the coax were eliminated.

### Spurious Frequencies

Off-frequency components in the RF voltage applied to the bridge may cause considerable error. The principal components of this type are harmonics and low-frequency subharmonics that may be fed through the final stage of the transmitter driving the bridge. The antenna is almost always a fairly selective circuit, and even though the system may be operating with a very low SWR at the desired frequency, it is almost always mismatched at harmonic and subharmonic frequencies. If such spurious frequencies are applied to the bridge in appreciable amplitude, the SWR indication will be very much in error. In particular, it may not be possible to obtain a null on the bridge with any set of adjustments of the matching circuit. The only remedy is to filter out the unwanted components by increasing the selectivity of the circuits between the transmitter final amplifier and the bridge.

### MEASURING LINE LENGTH

The following material is taken from information in September 1985 *QST* by Charlie Michaels, W7XC (see Bibliography).

There is a popular myth that one may prepare an open quarter-wave line by connecting a loop of wire to one end and trimming the line to resonance (as indicated by a dip meter). This actually yields a line with capacitive reactance equal to the inductive reactance of the loop: a 4-inch wire loop yields a line  $82.8^\circ$  line at 18 MHz; a 2-inch loop yields an  $86^\circ$  line. As the loop size is reduced, line length approaches—but never equals— $90^\circ$ .

To make a quarter-wave open line, parallel connect a coil and capacitor that resonate at the required frequency (see Fig 9A). After adjusting the network to resonance, do not make further network adjustments. Open the connection between the coil and capacitor and series connect the line to the pair. Start with a line somewhat longer than required, and trim it until the circuit again resonates at the desired frequency. For a shorted quarter-wave line or an open half-wave line, connect the line in parallel with the coil and capacitor (see Fig 9B).

Another method to accurately measure a coaxial transmission line length uses one of the popular “SWR analyzers,” portable hand-held instruments with a tunable

low-power signal generator and an SWR bridge. While an SWR analyzer cannot compute the very high values of SWR at the input of a shorted quarter-wave line at the fundamental frequency, most include another readout showing the magnitude of the impedance. This is very handy for finding a low-impedance dip, rather than a high-impedance peak.

At the operating frequency, a shorted quarter-wave line results in a high-impedance open-circuit at the input to that line. At twice the frequency, where the line is now one-half wave long electrically, the instrument shows a low-impedance short-circuit. However, when you are pruning a line to length by cutting off short pieces at the end, it is inconvenient to have to install a short before measuring the response. It is far easier to look for the dip in impedance when a quarter-wave line is terminated in an open circuit.

Again, the strategy is to start with a line physically a little longer than a quarter-wave length. A good rule of thumb is to cut the line 5% longer to take into account the variability in the velocity factor of a typical coax cable. Compute this using:

$$\text{Length (feet)} = 0.25 \times 1.05 \times \text{VF} \times 984 / \text{Freq} = \text{VF} / \text{Freq}$$

where

Freq is in MHz

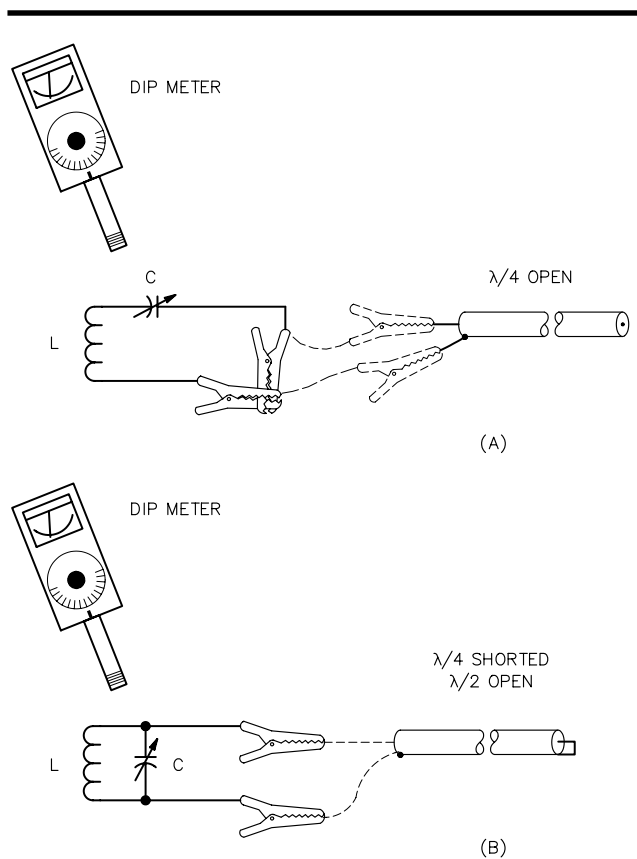
VF is the velocity factor in %.

Plug the coax connector installed at one end of the line into the SWR analyzer and find the frequency for the impedance dip. Prune the line by snipping off short pieces at the end. Once you've pruned the line to the desired frequency, connect the short at the end of the line and recheck for a short circuit at twice the fundamental frequency. Seal the shorted end of the coax and you're done.

## REFLECTOMETERS

Low-cost *reflectometers* that do not have a guaranteed wattmeter calibration are not ordinarily reliable for accurate numerical measurement of standing-wave ratio. They are, however, very useful as aids in the adjustment of matching networks, since the objective in such adjustment is to reduce the reflected voltage or power to zero. Relatively inexpensive devices can be used for this, since only good bridge balance is required, not actual calibration of SWR. Bridges of this type are usually frequency-sensitive—that is, the meter response increase with increasing frequency for the same applied voltage. When matching and line monitoring, rather than SWR measurement, is the principal use of the device, this is not a serious handicap.

Various simple reflectometers, useful for matching and monitoring, have been described from time to time in *QST* and in *The ARRL Handbook*. Because most of these are frequency sensitive, it is difficult to calibrate them accurately for power measurement, but their low cost and suitability for use at moderate power levels, combined with the ability to show accurately when a matching circuit has been properly adjusted, make them a worthwhile addition to the amateur station.



**Fig 9—Methods of determining  $1/4$  and  $1/2$ - $\lambda$  line lengths. At A,  $1/4$ - $\lambda$  open-circuited line; at B,  $1/4$ - $\lambda$  shorted and  $1/2$ - $\lambda$  open-circuited line.**



# The Tandem Match—An Accurate Directional Wattmeter

Most SWR meters are not very accurate at low power levels because the detector diodes do not respond to low voltage in a linear fashion. This design uses a compensating circuit to cancel diode nonlinearity. It also provides peak detection for SSB operation and direct SWR readout that does not vary with power level. The following information is condensed from an article by [John Grebenkemper, KI6WX](#), in January 1987 *QST*.

## DESIGN PRINCIPLES

Directional wattmeters for Amateur Radio use consist of three basic elements: a directional coupler, a detector and a signal-processing and display circuit. A directional coupler samples forward and reflected-power components on a transmission line. An ideal directional coupler would provide signals proportional to the forward and reflected voltages (independent of frequency), which could then be used to measure forward and reflected power over a wide frequency range. The best contemporary designs work over two decades of frequency.

The detector circuit provides a dc output voltage proportional to the ac input voltage. Most directional wattmeters use a single germanium diode as the detector element. A germanium, rather than silicon, diode is used to minimize diode nonlinearity at low power levels. Diode nonlinearity still causes SWR measurement errors unless it is compensated ahead of the display circuit. Most directional wattmeters do not work well at low power levels because of diode nonlinearity.

The signal-processing and display circuits compute and display the SWR. There are a number of ways to perform this function. Meters that display only the forward and reflected power require the operator to compute the SWR manually. Many instruments require that the operator adjust the meter to a reference level while measuring forward

power, then switch to measure reflected power on a special scale that indicates SWR. Meters that directly compute the SWR using analog signal-processing circuits have been described by [Fayman](#), [Perras](#), [Leenerts](#) and [Bailey](#) (see the Bibliography at the end of this chapter).

The next section takes a brief look at several popular circuits that accomplish the functions above and compares them to the circuits used in the Tandem Match. The design specifications of the Tandem Match are shown in **Table 1**, and a block diagram is shown in **Fig 11**.

## CIRCUIT DESCRIPTION

A directional coupler consists of an input port, an output port and a coupled port. The device takes a portion of the power flowing from the input port to the output port and directs it to the coupled port, but *none* of the power flowing from the output port to the input port is directed to the coupled port.

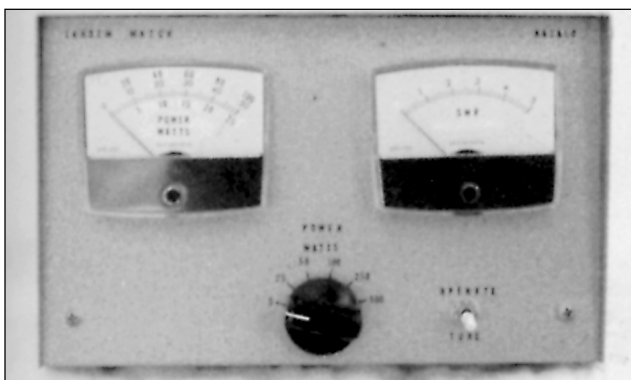
There are several terms that define the performance of a directional coupler:

1) *Insertion loss* is the amount of power that is lost as the signal flows from the input port to the output port. Insertion loss should be minimized so the coupler doesn't dissipate a significant amount of the transmitted power.

2) *Coupling factor* is the amount of power (or voltage) that appears at the coupled port relative to the amount of power (or voltage) transferred from the input port to the output port. The "flatness" (with frequency) of the coupling factor determines how accurately the directional wattmeter can determine forward and reflected power over a range of frequencies.

3) *Isolation* is the amount of power (or voltage) that appears at the coupled port relative to the amount of power (or voltage) transferred from the output port to the input port.

4) *Directivity* is the isolation less the coupling factor. Directivity dictates the minimum measurable SWR. A directional coupler with 20 dB of directivity measures a 1:1 SWR as 1.22:1, but one with 30 dB measures a 1:1 SWR as 1.07:1.



**Fig 10**—The Tandem Match uses a pair of meters to display net forward power and true SWR simultaneously.

**Table 1**

### Performance Specifications for the Tandem Match

Power range: 1.5 to 1500 W

Frequency range: 1.8 to 54 MHz

Power accuracy: Better than  $\pm 10\%$  ( $\pm 0.4$  dB)

SWR accuracy: Better than  $\pm 5\%$

Minimum SWR: Less than 1.05:1

Power display: Linear, suitable for use with either analog or digital meters

Calibration: Requires only an accurate voltmeter

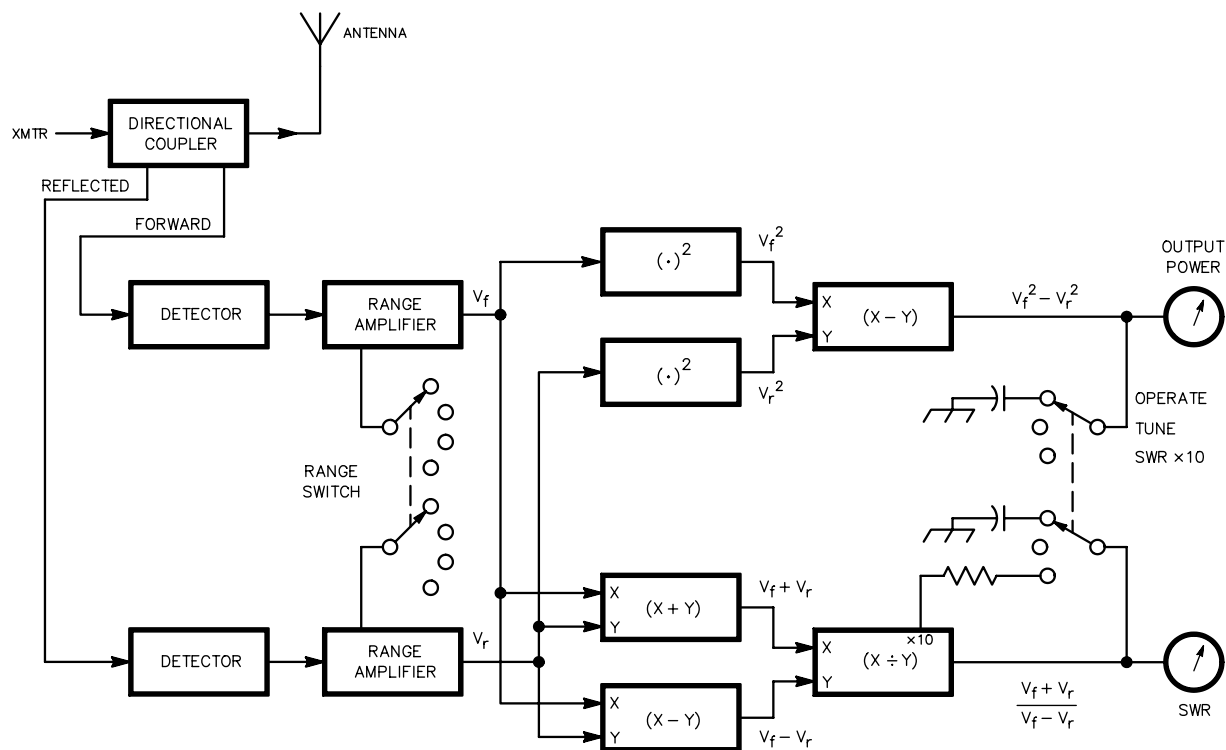


Fig 11—Block diagram of the Tandem Match.

The directional coupler most commonly used in amateur radio was first described in 1959 by Bruene in *QST* (see Bibliography). The coupling factor was fairly flat ( $\pm 1$  dB), and the directivity was about 20 dB for a Bruene coupler measured from 3 to 30 MHz. Both factors limit the accuracy of the Bruene coupler for measuring low values of power and SWR. It is a simple directional coupler, however, and it works well over a wide frequency range if great precision is not required.

The coupler used in the Tandem Match (see Fig 12) consists of a pair of toroidal transformers connected in tandem. The configuration was patented by Carl G. Sontheimer and Raymond E. Fredrick (US Patent no. 3,426,298, issued February 4, 1969). It has been described by Perras, Spaulding (see Bibliography) and others. With coupling factors of 20 dB or greater, this coupler is suitable for sampling both forward and reflected power.

The configuration used in the Tandem Match works well over the frequency range of 1.8 to 54 MHz, with a nominal coupling factor of 30 dB. Over this range, insertion loss is less than 0.1 dB. The coupling factor is flat to within  $\pm 0.1$  dB from 1.8 to 30 MHz, and increases to only  $\pm 0.3$  dB at 50 MHz. Directivity exceeds 35 dB from 1.8 to 30 MHz and exceeds 26 dB at 50 MHz.

The low-frequency limit of this directional coupler is determined by the inductance of the transformer secondary windings. The inductive reactance should be greater than 150  $\Omega$  (three times the line characteristic impedance) to

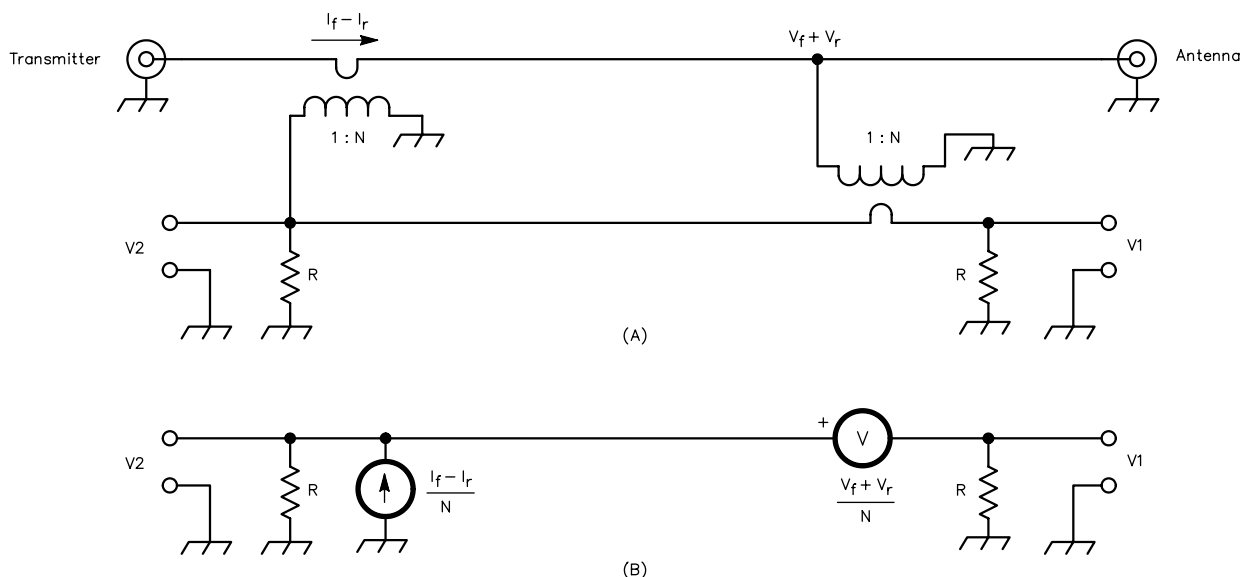
reduce insertion loss. The high-frequency limit of this directional coupler is determined by the length of the transformer windings. When the winding length approaches a significant fraction of a wavelength, coupler performance deteriorates.

The coupler described here may overheat at 1500 W on 160 meters (because of the high circulating current in the secondary of T2). The problem could be corrected by using a larger core or one with greater permeability. A larger core would require longer windings; that option would decrease the high-frequency limit.

### Detector Circuits

Most amateur directional wattmeters use a germanium diode detector to minimize the forward voltage drop. Detector voltage drop is still significant, however, and an uncompensated diode detector does not respond to small signals in a linear fashion. Many directional wattmeters compensate for diode nonlinearity by adjusting the meter scale.

The effect of underestimating detected power worsens at low power levels. Under these conditions, the ratio of the forward power to the reflected power is overestimated because the reflected power is always less than the forward power. This results in an instrument that underestimates SWR, particularly as power is reduced. A directional wattmeter can be checked for this effect by measuring SWR at several power levels: the SWR should be independent of power level.



**Fig 12—Simplified diagram of the Tandem Match directional coupler. At A, a schematic of the two transformers. At B, an equivalent circuit.**

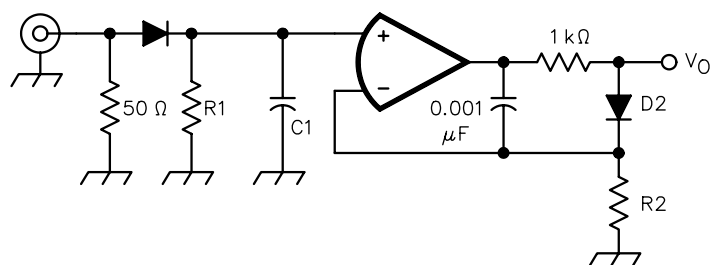
The Tandem Match uses a feedback circuit to compensate for diode nonlinearity. A simplified diagram of the compensated detector is shown in **Fig 13**. When used with the 30-dB directional coupler, the output voltage of this circuit tracks the square root of power over a range from 10 mW to 1.5 kW. The compensated diode detector tracks the peak input voltage down to 30 mV, while an uncompensated germanium-diode detector shows significant errors at peak inputs of 1 V and less. More information about compensated detectors appears in [Grebekemper's QEX](#) article, "Calibrating Diode Detectors" (see Bibliography).

The compensation circuit uses the voltage across a feedback diode, D2, to compensate for the voltage drop across the detector diode, D1. (The diodes must be a matched pair.) The average current through D1 is determined by the detector diode load resistor, R1. The peak current through this diode is several times larger than the average current; therefore, the current through D2 must be several times larger than the average current through D1 to compensate adequately for the peak voltage drop across D1. This is accomplished by making

the feedback-diode load resistor, R2, several times smaller than R1. The voltage at the output of the compensated detector approximates the peak RF voltage at the input. For Schottky barrier diodes and a 1 MΩ detector-diode load resistor, a 5:1 ratio of R1 to R2 is nearly optimal.

### Signal-Processing and Display Circuits

The signal-processing circuitry calculates and displays transmission-line power and SWR. When measuring forward power, most directional wattmeters display the actual forward power present in the transmission line, which is the sum of forward and reflected power if a match exists at the input end of the line. Transmission-line forward power is very close to the net forward power (the actual power delivered to the line) so long as the SWR is low. As the SWR increases, however, forward power becomes an increasingly poor measure of the power delivered to the load. At an SWR of 3:1, a forward power reading of 100 W implies that only 75 W is delivered to the load (the reflected power is 25 W), assuming the transmission-line loss is zero.



**Fig 13—Simplified diagram of the detector circuit used in the Tandem Match. The output voltage,  $V_o$ , is approximately equal to the input voltage. D1 and D2 must be a matched pair (see text). The op amp should have a low offset voltage (less than 1 mV), a low leakage current (less than 1 nA), and be stable over time and temperature. The resistor and capacitor in the feedback path assure that the op amp will be stable.**

The Tandem Match differs from most wattmeters in that *it displays the net forward power, rather than the sum of forward and reflected power*. This is the quantity that must be optimized to result in maximum radiated power (and which concerns the FCC).

The Tandem Match directly computes and displays the transmission-line SWR on a linear scale. As the displayed SWR is not affected by changes in transmitter power, a matching network can be simply adjusted to minimize SWR. Transmatch adjustment requires only a few watts.

The heart of the Tandem Match signal-processing circuit is the analog logarithm and antilogarithm circuitry shown in **Fig 14**. The circuit is based on the fact that collector current in a silicon transistor is proportional to the exponential (antilog) of its base-emitter voltage over a range of collector currents from a few nanoamperes to a few milliamperes when the collector-base voltage is zero (see [Gibbons and Horn](#) reference in the Bibliography). Variations of this circuit are used in the squaring circuits to convert voltage to power and in the divider circuit used to compute the SWR. With good op amps, this circuit will work well for input voltages from less than 100 mV to greater than 10 V.

(For the Tandem Match, “good” op amps are quad-packaged, low-power-consumption, unity-gain-stable parts with input bias less than 1 nA and offset voltage less than 5 mV. Op amps that consume more power than those shown may require changes to the power supply.)

### CONSTRUCTION

The schematic diagram for the Tandem Match is shown in **Fig 15** (see pages 14 and 15). The circuit is designed to

operate from batteries and draw very little power. Much of the circuitry is of high impedance, so take care to isolate it from RF fields. House it in a metal case. Most problems in the prototype were caused by stray RF in the op-amp circuitry.

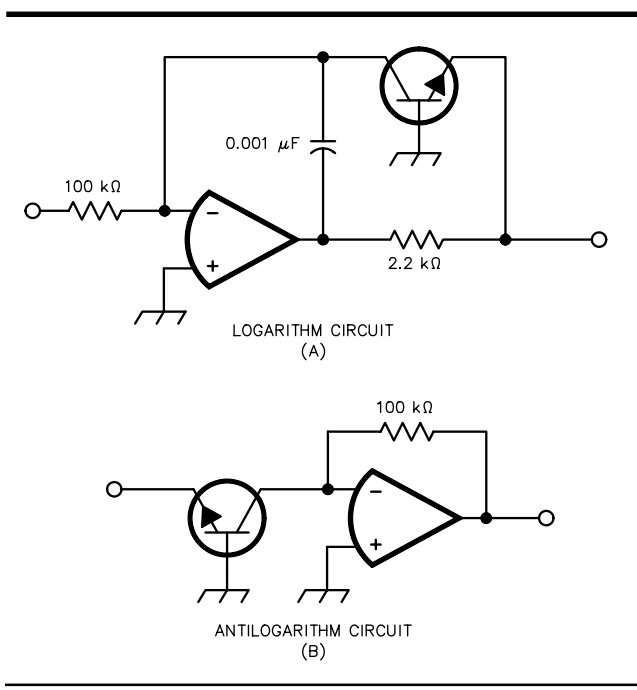
### Directional Coupler

The directional coupler is constructed in its own small ( $2\frac{3}{4} \times 2\frac{3}{4} \times 2\frac{1}{4}$ -inch) aluminum box (see **Fig 16**). Two pairs of S0-239 connectors are mounted on opposite sides of the box. A piece of PC board is run diagonally across the box to improve coupler directivity. The pieces of RG-8X coaxial cable pass through holes in the PC board.

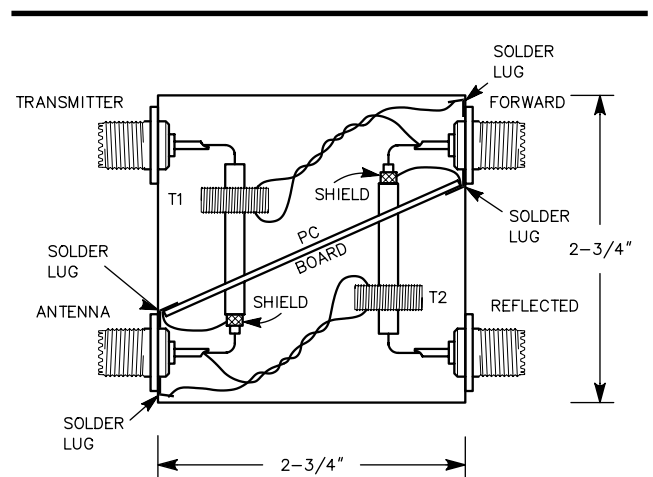
(Note: Some brands of “mini 8” cable have extremely low breakdown voltage ratings and are unsuitable to carry even 100 W when the SWR exceeds 1:1. See the subsequent section, “High-Power Operation,” for details of a coupler made with RG-8 cable.)

Begin by constructing T1 and T2, which are identical except for their end connections. Refer to Fig 16. The primary for each transformer is the center conductor of a length of RG-8X coaxial cable. Cut two cable lengths sufficient for mounting as shown in the figure. Strip the cable jacket, braid and dielectric as shown. The cable braid is used as a Faraday shield between the transformer windings, so it is only grounded at one end. *Important—connect the braid only at one end or the directional-coupler circuit will not work properly!* Wind two transformer secondaries, each 31 turns of #24 enameled wire on an Amidon T50-3 or equivalent powdered-iron core.

Slip each core over one of the prepared cable pieces (including both the shield and the outer insulation). Mount and connect the transformers as shown in Fig 16, with the wire running through separate holes in the copper-clad PC board. The directional coupler can be mounted separately from the rest of the circuitry if desired. If so, use two coaxial cables to carry the forward and reflected-power signals from the



**Fig 14**—Simplified diagrams of the log circuit at A and the antilog circuit at B.



**Fig 16**—Construction details for the directional coupler.

directional coupler to the detector inputs. Be aware, however that any losses in the cables will affect power readings.

This directional coupler has not been used at power levels in excess of 100 W. For more information about using the Tandem Match at high power levels, see the section, “High-Power Operation.”

### Detector and Signal-Processing Circuits

The detector and signal-processing circuits were constructed on a perforated, copper-clad circuit board. These circuits use two separate grounds—it is extremely important that the grounds be isolated as shown in the circuit diagram. Failure to do so may result in faulty circuit operation. Separate grounds prevent RF currents on the cable braid from affecting the op-amp circuitry.

The directional coupler requires good 50-Ω loads. They are constructed on the back of female UHF chassis connectors where the cables from the directional coupler enter the wattmeter housing. Each load consists of four 200-Ω resistors connected from the center conductor of the UHF connector to the four holes on the mounting flange, as shown in Fig 17. The detector diode is then run from the center conductor of the connector to the 100-pF and 1000-pF bypass capacitors, which are mounted next to the connector. The response of this load and detector combination measures flat to beyond 500 MHz.

Schottky-barrier diodes (type 1N5711) were used in this design because they were readily available. Any RF-detector diode with a low forward voltage drop (less than 300 mV) and reverse break-down voltage greater than 30 V could be used. (Germanium diodes could be used in this circuit, but performance will suffer. If germanium diodes are used, reduce the resistance values for the detector-diode and feedback-diode load resistors by a factor of 10.)

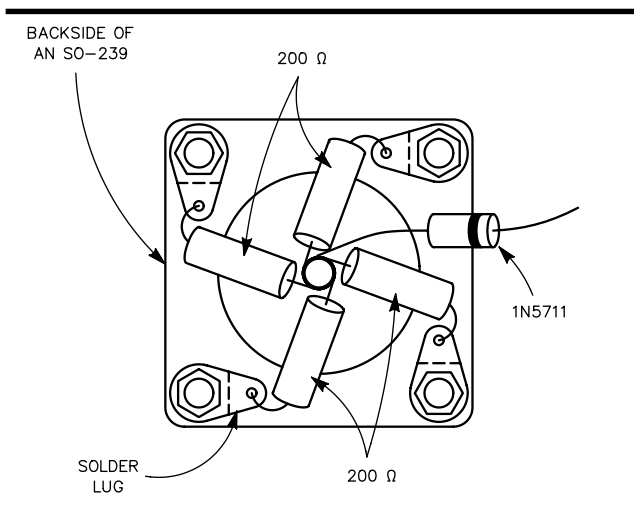


Fig 17—The parallel load resistors mounted on an SO-239 connector. Four 200-Ω, 2%, 1/2-W resistors are mounted in parallel to provide a 50-Ω detector load.

The detector diodes must be matched. This can be done with dc, using the circuit shown in Fig 18. Use a high-impedance voltmeter (10 MΩ or greater). For this project, diodes are matched when their forward voltage drops are equal (within a few millivolts). Diodes from the same batch will probably be sufficiently matched.

The rest of the circuit layout is not critical, but keep the lead lengths of the 0.001 and 0.01-pF bypass capacitors short. The capacitors provide additional bypassing for the op-amp circuitry. D6 and D7 form a voltage doubler to detect the presence of a carrier. When the forward power exceeds 1.5 W, Q3 switches on and stays on until about 10 seconds after the carrier drops. (A connection from TP7 to TP9 forces the unit on, even with no carrier present.) The regulated references of +2.5 V and -2.5 V generated by the LM334 and two LM336s are critical. Zener-diode substitutes would significantly degrade performance.

The four op amps in U1 compensate for the nonlinearity of the detector diodes. D1-D2 and D3-D4 are the matched diode pairs discussed above. A RANGE switch selects the meter range. (A six-position switch was used here because it was handy.) The resistor values for the RANGE switch are shown in Table 2. Full-scale input power gives an output at U1C or U1D of 7.07 V. The forward and reflected-power detectors are zeroed with R1 and R2.

The forward and reflected-detector voltages are squared by U2, U5 and U6 so that the output voltages are proportional to forward and reflected power. The gain constants are adjusted using R3 and R4 so that an input of 7.07 V to the squaring circuit gives an output of 5 V. The difference between these two voltages is used by U4B to yield an output that is proportional to the power delivered to the transmission line. This voltage is peak detected (by an RC circuit connected to the OPERATE position of the MODE switch) to hold and indicate the maximum power during CW or SSB transmissions. SWR is computed from the forward and reflected voltages by U3, U4 and U7. When no carrier is present, Q4 forces the SWR reading to be zero (that is, when the forward power is less than 2% of the full-scale setting of the RANGE switch). The SWR computation circuit gain is adjusted by R5. The output is peak detected in the OPERATE mode to steady the SWR reading during CW or SSB transmissions.

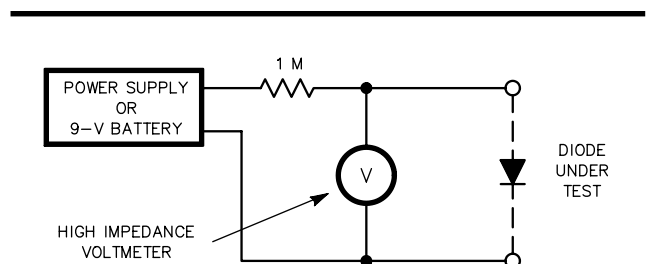
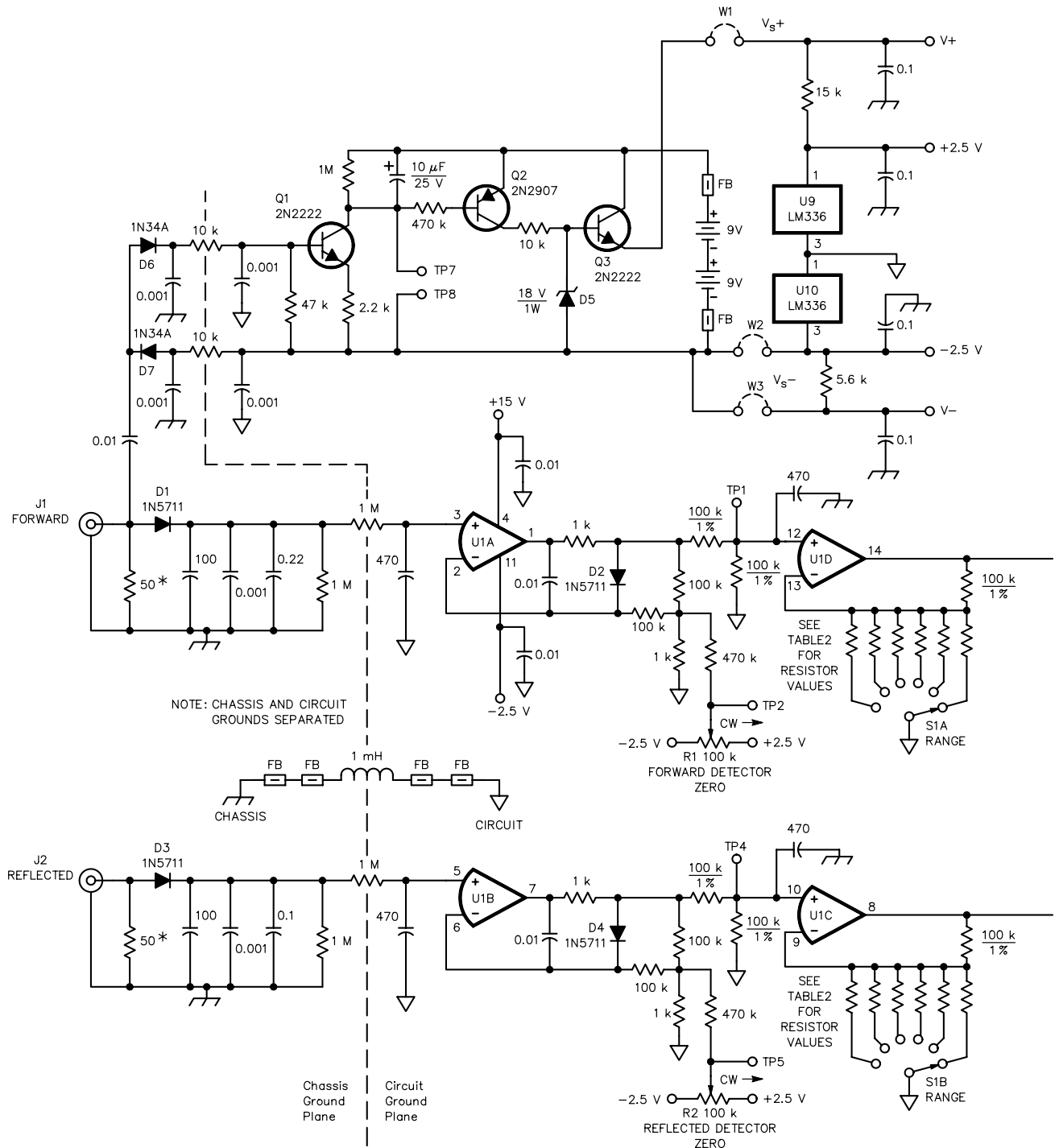


Fig 18—Diode matching test setup.



NOTE: CHASSIS AND CIRCUIT  
GROUNDS SEPARATED

Chassis  
Ground  
Plane

Circuit  
Ground  
Plane

**Fig 15—Schematic diagram for the Tandem Match directional wattmeter. Parts identified as RS are from Radio Shack. For other parts sources, see Table 3. See Fig 17 for construction of 50-Ω loads at J1 and J2.**

**D1, D2—Matched pair 1N5711, or equivalent.**  
**D3, D4—Matched pair 1N5711, or equivalent.**  
**D6, D7—1N34A.**  
**D8-D14—1N914.**  
**FB—Ferrite bead, Amidon FB-73-101 or equiv.**

**J1, J2—SO-239 connector.**  
**J3, J4—Open-circuit jack.**  
**M1, M2—50 µA panel meter, RS 270-1751.**  
**Q1, Q3, Q4—2N2222 or equiv.**  
**Q2—2N2907 or equiv.**

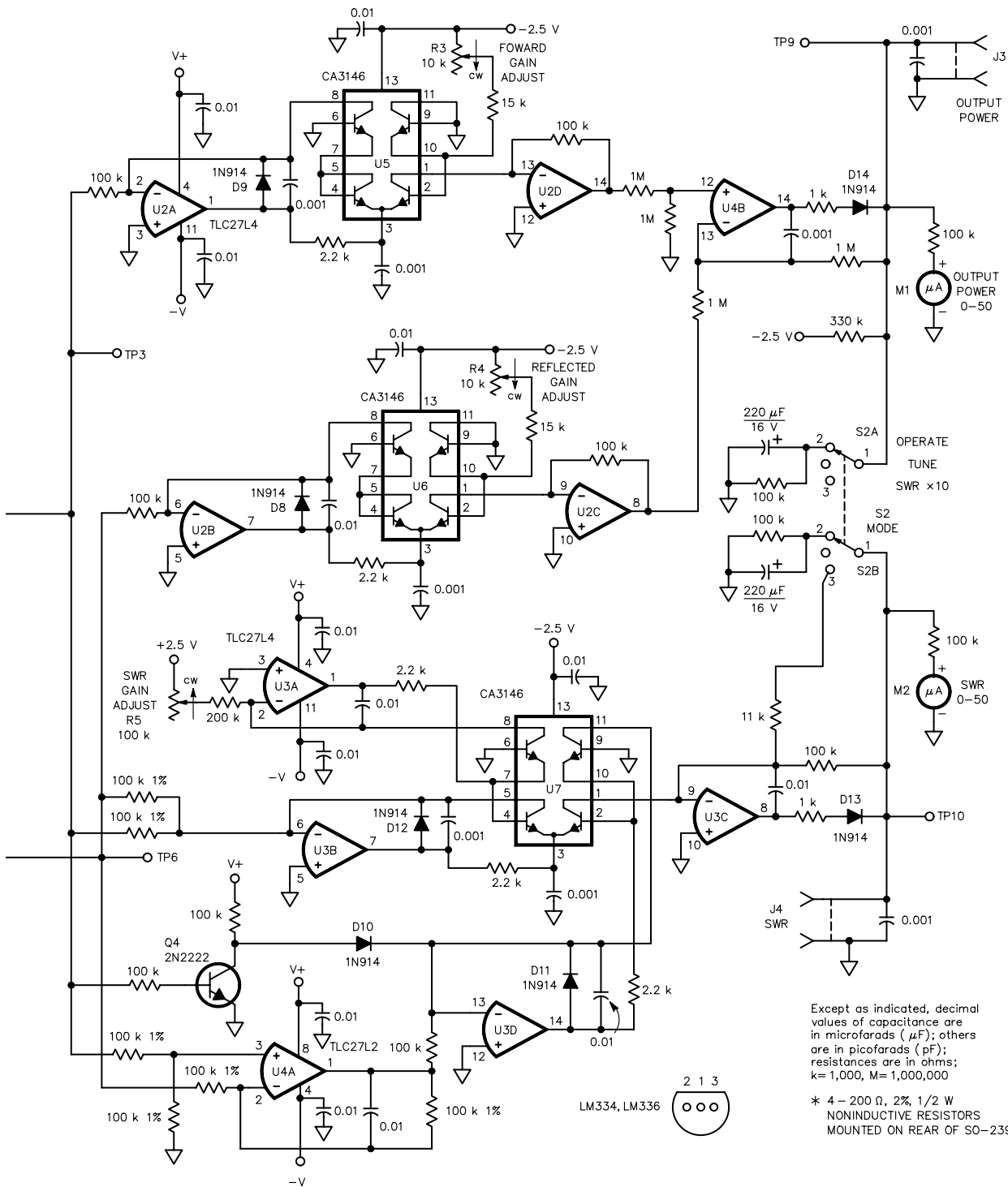


Figure 15

R1, R2, R5—100 k $\Omega$ , 10-turn, cermet Trimpot.  
 R3, R4—10 k $\Omega$ , 10-turn, cermet Trimpot.  
 U1-U3—TLC27L4 or TLC27M4 quad op amp  
 (Texas Instruments).  
 U4—TLC27L2 or TLC27M2 dual op amp.

U5-U7—CA3146 quad transistor array.  
 U8—LM334 adjustable current source.  
 U9-U10—LM336 2.5-V reference diode. See text.

**Table 2****Range-Switch Resistor Values**

Full-Scale Power Level (W)	Range Resistor (k $\Omega$ ) (1% Precision)
1	2.32
2	3.24
3	4.02
5	5.23
10	7.68
15	9.53
20	11.0
25	12.7
30	14.0
50	18.7
100	28.7
150	37.4
200	46.4
250	54.9
300	63.4
500	100.0
1000	237.0
1500	649.0
2000	Open

Transistor arrays (U5, U6 and U7) are used for the log and antilog circuits to guarantee that the transistors will be well matched. Discrete transistors may be used, but accuracy may suffer. A three-position toggle switch selects the three operating modes. In the OPERATE mode, the power and SWR outputs are peak detected and held for a few seconds to allow meter reading during actual transmissions. In the TUNE mode, the meters display instantaneous output power and SWR.

A digital voltmeter is used to obtain more precise readings than are possible with analog meters. The output power range is 0 to 5 V (0 V = 0 W and 5 V = full scale). SWR output varies from 1 V (SWR = 1:1) to 5 V (SWR = 5:1). Voltages above 5 V are unreliable because of voltage limiting in some of the op amp circuits.

**Calibration**

The directional wattmeter can be calibrated with an accurate voltmeter. All calibration is done with dc voltages. The directional-coupler and detector circuits are inherently accurate if correctly built. To calibrate the wattmeter, use the following procedure:

- 1) Set the MODE switch to TUNE and the RANGE switch to 100 W or less.
- 2) Jumper TP7 to TP8. This turns the unit on.
- 3) Jumper TP1 to TP2. Adjust R1 for 0 V at TP3.
- 4) Jumper TP4 to TP5. Adjust R2 for 0 V at TP6.
- 5) Adjust R1 for 7.07 V at TP3.
- 6) Adjust R3 for 5.00 V at TP9, or a full-scale reading on M1.
- 7) Adjust R2 for 7.07 V at TP6.

- 8) Adjust R4 for 0 V at TP9, or a zero reading on M1.
- 9) Adjust R2 for 4.71 V at TP6.
- 10) Adjust R5 for 5.00 V at TP10, or a full-scale reading on M2.
- 11) Set the RANGE switch to its most sensitive scale.
- 12) Remove the jumpers from TP1 to TP2 and TP4 to TP5.
- 13) Adjust R1 for 0 V at TP3.
- 14) Adjust R2 for 0 V at TP6.
- 15) Remove the jumper from TP7 to TP8.

This completes the calibration procedure. This procedure has been found to equal calibration with expensive laboratory equipment. The directional wattmeter should now be ready for use.

**ACCURACY**

Performance of the Tandem Match has been compared to other well-known directional couplers and laboratory test equipment, and it equals any amateur directional wattmeter tested. Power measurement accuracy compares well to a Hewlett-Packard HP-436A power meter. The HP meter has a specified measurement error of less than  $\pm 0.05$  dB. The Tandem Match tracked the HP436A within  $\pm 0.5$  dB from 10 mW to 100 W, and within  $\pm 0.1$  dB from 1 W to 100 W. The unit was not tested above 100 W because a transmitter with a higher power rating was not available.

SWR performance was equally good when compared to the SWR calculated from measurements made with the HP436A and a calibrated directional coupler. The Tandem Match tracked the calculated SWR within  $\pm 5\%$  for SWR values from 1:1 to 5:1. SWR measurements were made at 8 W and 100 W.

**OPERATION**

Connect the Tandem Match in the 50- $\Omega$  line between the transmitter and the antenna matching network (or antenna if no matching network is used). Set the RANGE switch to a range greater than the transmitter output rating and the MODE switch to TUNE. When the transmitter is keyed, the Tandem Match automatically switches on and indicates both power delivered to the antenna and SWR on the transmission line. When no carrier is present, the OUTPUT POWER and SWR meters indicate zero.

The OPERATE mode includes RC circuitry to momentarily hold the peak-power and SWR readings during CW or SSB transmissions. The peak detectors are not ideal, so there could be about 10% variation from the actual power peaks and the SWR reading. The SWR  $\times 10$  mode increases the maximum readable SWR to 50:1. This range should be sufficient to cover any SWR value that occurs in amateur use. (A 50-foot open stub of RG-8 yields a measured SWR of only 43:1, or less, at 2.4 MHz because of cable loss. Higher frequencies and longer cables exhibit a lesser maximum SWR.)

It is easy to use the Tandem Match to adjust an antenna matching network: Adjust the transmitter for minimum output power (at least 1.5 W). With the carrier on and the MODE switch set to TUNE or SWR  $\times 10$ , adjust the matching network for minimum SWR. Once the minimum SWR is obtained, set



the transmitter to the proper operating mode and output power. Place the Tandem Match in the OPERATE mode.

## DESIGN VARIATIONS

There are several ways in which this design could be enhanced. The most important is to add UHF capability. This would require a new directional-coupler design for the band of interest. (The existing detector circuit should work to at least 500 MHz.)

Those who desire a low-power directional wattmeter can build a directional coupler with a 20-dB coupling factor by decreasing the transformer turns ratio to 10:1. That version should be capable of measuring output power from 1 mW to about 150 W (and it should switch on at about 150 mW).

This change should also increase the maximum operating frequency to about 150 MHz (by virtue of the shorter transformer windings). If you desire 1.8-MHz operation, it may be necessary to change the toroidal core material for sufficient reactance (low insertion loss).

The Tandem Match circuit can accommodate coaxial cable with a characteristic impedance other than 50 Ω. The detector terminating resistors, transformer secondaries and range resistors must change to match the new design impedance.

The detector circuitry can be used (without the directional coupler) to measure low-level RF power in 50-Ω circuits. RF is fed directly to the forward detector (J1, Fig 15), and power is read from the output power meter. The detector is quite linear from 10 μW to 1.5 W.

## HIGH-POWER OPERATION

This material was condensed from information by Frank Van Zant, KL7IBA, in July 1989 *QST*. In April 1988, Zack Lau, W1VT, described a directional-coupler circuit (based on the same principle as Grebenkemper's circuit) for a QRP transceiver (see the Bibliography at the end of this chapter). The main advantage of Lau's circuit is a very low parts count.

Grebenkemper used complex log-antilog amplifiers to provide good measurement accuracy. This application gets away from complex circuitry, but retains reasonable measurement accuracy over the 1 to 1500-W range. It also forfeits the SWR-computation feature. Lau's coupler uses ferrite toroids. It works well at low power levels, but the ferrite toroids heat excessively with high power, causing erratic meter readings and the potential for burned parts.

### The Revised Design

Powdered-iron toroids are used for the transformers in this version of Lau's basic circuit. The number of turns on the secondaries was increased to compensate for the lower permeability of powdered iron.

Two meters display reflected and forward power (see Fig 19). The germanium detector diodes (D1 and D2—1N34) provide fairly accurate meter readings, particularly if the meter is calibrated (using R3, R4 and R5) to place the normal

transmitter output at mid scale. If the winding sense of the transformers is reversed, the meters are transposed (the forward-power meter becomes the reflected-power meter, and vice versa).

## Construction

Fig 20 shows the physical layout of the coupler. The pickup unit is mounted in a 3½ × 3½ × 4-inch box. The meters, PC-mount potentiometers and HIGH/LOW power switch are mounted in a separate box or a compartment in an antenna tuner. Parts for this project are available from the suppliers listed in Table 3.

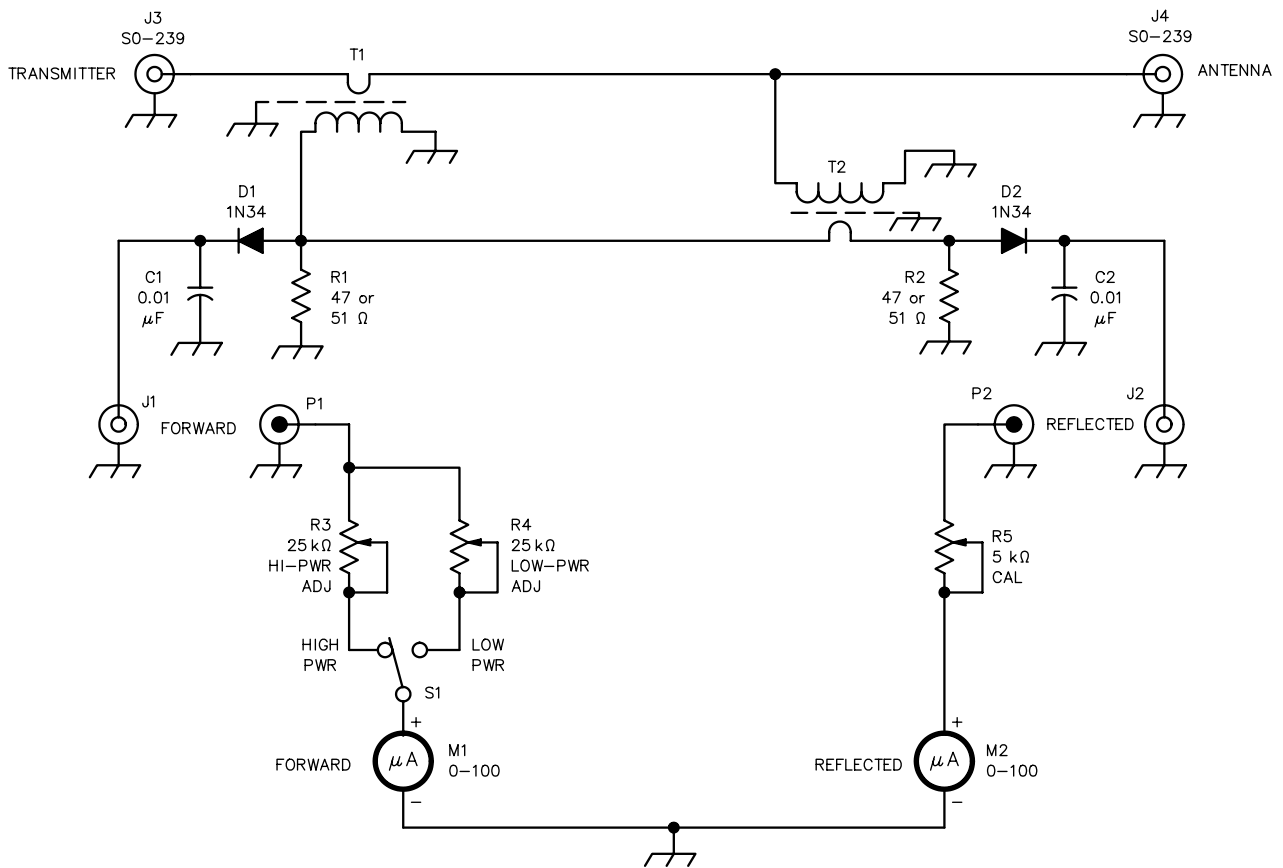
The primary windings of T1 and T2 are constructed much as Grebenkemper described, but use RG-8 with its jacket removed so that the core and secondary winding may fit over the cable. The braid is wrapped with fiberglass tape to insulate it from the secondary winding. An excellent alternative to fiberglass tape—with even higher RF voltage-breakdown characteristics—is ordinary plumber's Teflon pipe tape, available at most hardware stores.

The transformer secondaries are wound on T-68-2 powdered-iron toroid cores. They are 40 turns of #26 to #30 enameled wire spread evenly around each core. By using #26 to #30 wire on the cores, the cores slip over the tape-wrapped RG-8 lines. With #26 wire on the toroids, a single

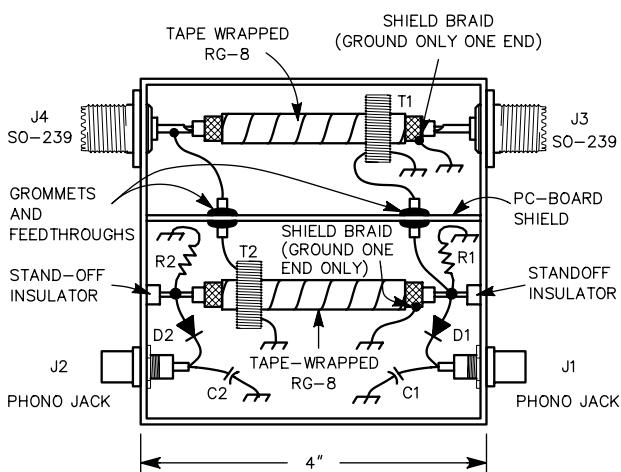
**Table 3**  
**Parts Sources**

(Also see Chapter 21)

Components	Source
TLC-series and CA3146 ICs	Newark Electronics 4801 N Ravenswood St Chicago, IL 60640 773-784-5100
LM334, LM336, 1% resistors, trimmer potentiometers	Digi-Key Corporation 701 Brooks Ave S PO Box 677 Thief River Falls, MN 56701 800-344-4539
Toroid cores, Fiberglass tape	Amidon Associates 240 & 250 Briggs Ave Costa Mesa, CA 92626 714-850-4660
Meters	Fair Radio Sales PO Box 1105 Lima, OH 45804 419-227-6573
Toroid cores	Palomar Engineers PO Box 462222 Escondido, CA 92046 760-747-3343
0-150/1500-W-scale meters, A&M model no. 255-138, 1N5711 diodes	Surplus Sales of Nebraska 1502 Jones St Omaha, NE 68102 402-346-4750



**Fig 19—Schematic diagram of the high-power directional coupler. D1 and D2 are germanium diodes (1N34 or equiv). R1 and R2 are 47 or 51-Ω, 1/2-W resistors. C1 and C2 have 500-V ratings. The secondary windings of T1 and T2 each consist of 40 turns of #26 to #30 enameled wire on T-68-2 powdered-iron toroid cores. If the coupler is built into an existing antenna tuner, the primary of T1 can be part of the tuner coaxial output line. The remotely located meters (M1 and M2) are connected to the coupler box at J1 and J2 via P1 and P2.**



**Fig 20—Directional-coupler construction details. Grommets or feedthrough insulators can be used to route the secondary winding of T1 and T2 through the PC board shield. A 3 1/2 × 3 1/2 × 4-inch box serves as the enclosure.**

layer of tape (slightly more with Teflon tape) over the braid provides an extremely snug fit for the core. Use care when fitting the cores onto the RG-8 assemblies.

After the toroids are mounted on the RG-8 sections, coat the assembly with General Cement Corp Polystyrene Q Dope, or use a spot or two of RTV sealant to hold the windings in place and fix the transformers on the RG-8 primary windings.

Mount a PC-board shield in the center of the box, between T1 and T2, to minimize coupling between the transformers. Suspend T1 between the SO-239 connectors and T2 between two standoff insulators. The detector circuits (C1, C2, D1, D2, R1 and R2) are mounted inside the coupler box as shown.

### Calibration, Tune Up and Operation

The coupler has excellent directivity. Calibrate the meters for various power levels with an RF ammeter and a 50-Ω dummy load. Calculate  $I^2R$  for each power level, and mark the meter faces accordingly. Use R3, R4 and R5 to

adjust the meter readings within the ranges. Diode nonlinearities are thus taken into account, and Grebenkemper's signal-processing circuits are not needed for relatively accurate power readings. Start the tune-up process using about 10 W, adjust the antenna tuner for minimum reflected power, and increase power while adjusting the tuner to minimize reflected power.

This circuit has been built into several antenna tuners with good success. The instrument works well at 1.5-kW output on 1.8 MHz. It also works well from 3.5 to 30 MHz with 1.2 and 1.5-kW output.

The antenna is easily tuned for a 1:1 SWR using the

null indication provided. Amplifier settings for a matched antenna, as indicated with the wattmeter, closely agreed with those for a 50-Ω dummy load. Checks with a Palomar noise bridge and a Heath Antenna Scope also verified these findings. This circuit should handle more than 1.5 kW, as long as the SWR on the feed line through the wattmeter is kept at or near 1:1. (On one occasion high power was applied while the antenna tuner was not coupled to a load. Naturally the SWR was extremely high, and the output transformer secondary winding opened like a fuse. This resulted from the excessively high voltage across the secondary. The damage was easily and quickly repaired.)

## An Inexpensive VHF Directional Coupler

Precision in-line metering devices capable of reading forward and reflected power over a wide range of frequencies are very useful in amateur VHF and UHF work, but their rather high cost puts them out of the reach of many VHF enthusiasts. The device shown in Figs 14, 15 and 16 is an inexpensive adaptation of their basic principles. It can be made for the cost of a meter, a few small parts, and bits of copper pipe and fittings that can be found in the plumbing stocks at many hardware stores.

### Construction

The sampler consists of a short section of handmade coaxial line, in this instance, of 50 Ω impedance, with a reversible probe coupled to it. A small pickup loop built into the probe is terminated with a resistor at one end and a diode at the other. The resistor matches the impedance of the loop, not the impedance of the line section. Energy picked up by the loop is rectified by the diode, and the resultant current is fed to a meter equipped with a calibration control.

The principal metal parts of the device are a brass plumbing T, a pipe cap, short pieces of 3/4-inch ID and 5/16-inch OD copper pipe, and two coaxial fittings. Other available tubing combinations for 50-Ω line may be usable.

The ratio of outer conductor ID to inner conductor OD should be 2.4/1. For a sampler to be used with other impedances of transmission line, see Chapter 24 for suitable ratios of conductor sizes. The photographs and Fig 21 show construction details.

Soldering of the large parts can be done with a 300-watt iron or a small torch. A neat job can be done if the inside of the T and the outside of the pipe are tinned before assembling. When the pieces are reheated and pushed together, a good mechanical and electrical bond will result. If a torch is used, go easy with the heat, as an overheated and discolored fitting will not accept solder well.

Coaxial connectors with Teflon or other heat-resistant insulation are recommended. Type N, with split-ring retainers for the center conductors, are preferred. Pry the split-ring washers out with a knife point or small screwdriver. Don't lose them, as they'll be needed in the final assembly.

The inner conductor is prepared by making eight radial cuts in one end, using a coping saw with a fine-toothed blade, to a depth of 1/2 inch. The fingers so made are then bent together, forming a tapered end, as shown in Figs 22 and 23. Solder the center pin of a coaxial fitting into this, again being careful not to overheat the work.

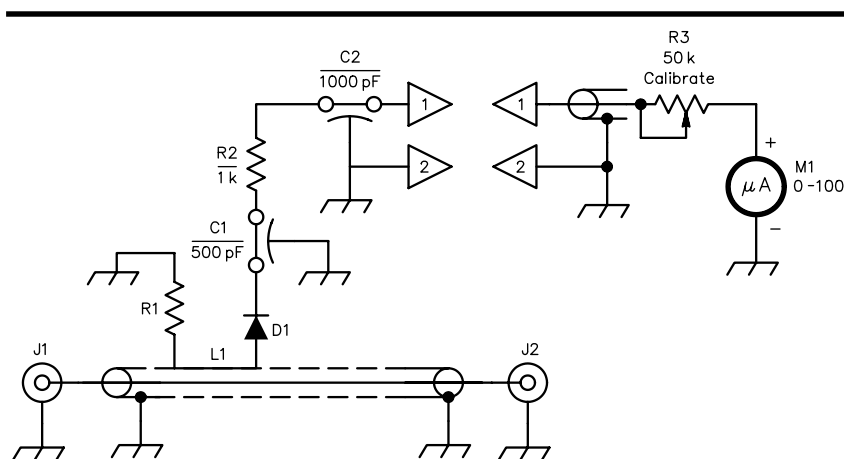


Fig 21—Circuit diagram for the line sampler.

- C1—500-pF feedthrough capacitor, solder-in type.
- C2—1000-pF feedthrough capacitor, threaded type.
- D1—Germanium diode 1N34, 1N60, 1N270, 1N295, or similar.
- J1, J2—Coaxial connector, type N (UG-58A).
- L1—Pickup loop, copper strap 1-inch long×3/16-inch wide. Bend into "C" shape with flat portion 5/8-inch long.
- M1—0-100 μA meter.
- R1—Composition resistor, 82 to 100 Ω. See text.
- R3—50-kΩ composition control, linear taper.

In preparation for soldering the body of the coax connector to the copper pipe, it is convenient to use a similar fitting clamped into a vise as a holding fixture. Rest the T assembly on top, held in place by its own weight. Use the partially prepared center conductor to assure that the coax connector is concentric with the outer conductor. After being sure that the ends of the pipe are cut exactly perpendicular to the axis, apply heat to the coax fitting, using just enough

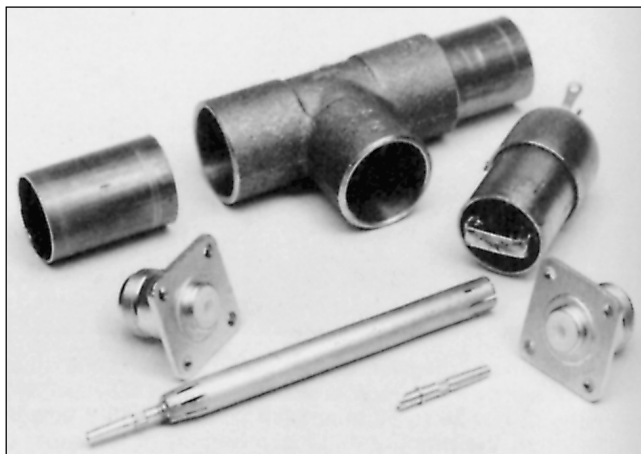
so a smooth fillet of solder can be formed where the flange and pipe meet.

Before completing the center conductor, check its length. It should clear the inner surface of the connector by the thickness of the split ring on the center pin. File to length; if necessary, slot as with the other end, and solder the center pin in place. The fitting can now be soldered onto the pipe, to complete the 50-Ω line section.

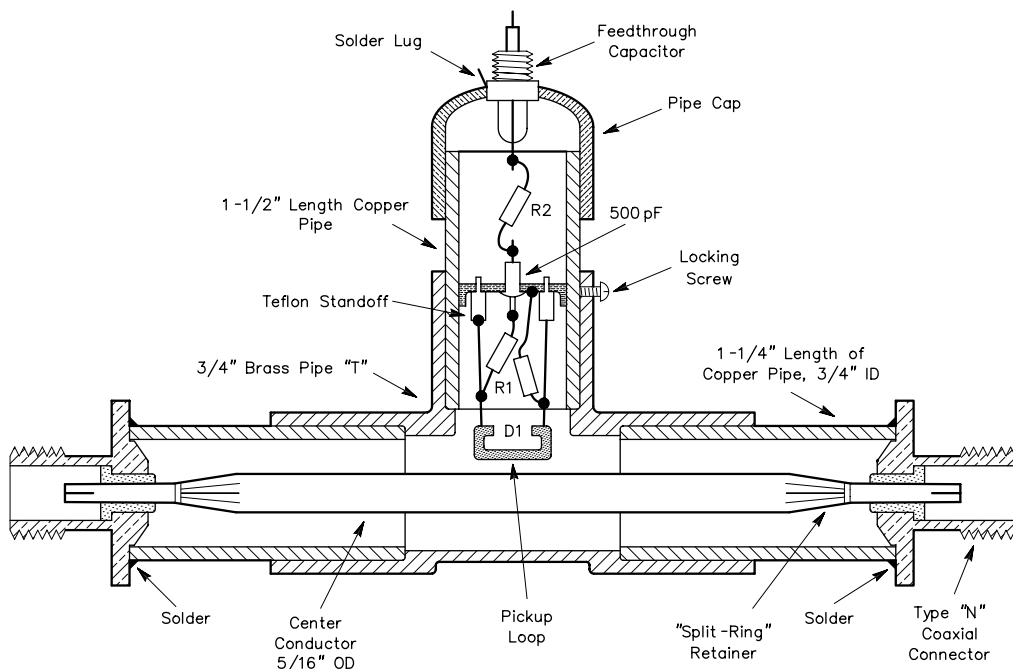
The probe assembly is made from a 1½ inch length of the copper pipe, with a pipe cap on the top to support the upper feedthrough capacitor, C2. The coupling loop is mounted by means of small Teflon standoffs on a copper disc, cut to fit inside the pipe. The diode, D1, is connected between one end of the loop and a 500-pF feedthrough capacitor, C1, soldered into the disc. The terminating resistor, R1, is connected between the other end of the loop and ground, as directly as possible.

When the disc assembly is completed, insert it into the pipe, apply heat to the outside, and solder the tabs in place by melting solder into the assembly at the tabs. The position of the loop with respect to the end of the pipe will determine the sensitivity of a given probe. For power levels up to 200 watts the loop should extend beyond the face of the pipe about 5/32 inch. For use at higher power levels the loop should protrude only 3/32 inch. For operation with very low power levels the best probe position can be determined by experiment.

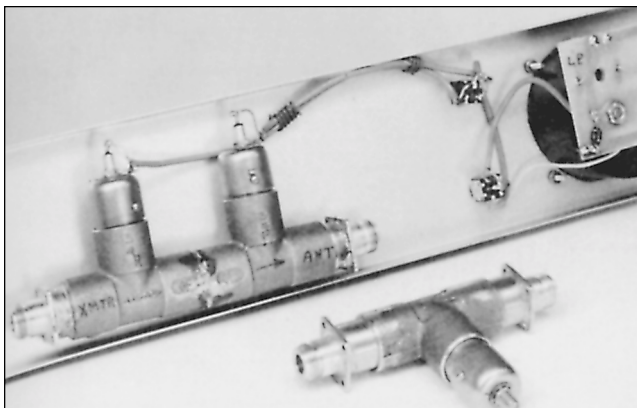
The decoupling resistor, R2, and feedthrough capacitor, C2, can be connected, and the pipe cap put in place. The



**Fig 22—Major components of the line sampler. The brass T and two end sections are at the upper left in this picture. A completed probe assembly is at the right. The N connectors have their center pins removed. The pins are shown with one inserted in the left end of the inner conductor and the other lying in the right foreground.**



**Fig 23—Cross-section view of the line sampler. The pickup loop is supported by two Teflon standoff insulators. The probe body is secured in place with one or more locking screws through holes in the brass T.**



**Fig 24—Two versions of the line sampler. The single unit described in detail here is in the foreground. Two sections in a single assembly provide for monitoring forward and reflected power without probe reversal.**

threaded portion of the capacitor extends through the cap. Put a solder lug over it before tightening its nut in place. Fasten the cap with two small screws that go into threaded holes in the pipe.

### Calibration

The sampler is very useful for many jobs even if it is not accurately calibrated, although it is desirable to calibrate it against a wattmeter of known accuracy. A good 50- $\Omega$  VHF dummy load is required.

The first step is to adjust the inductance of the loop, or the value of the terminating resistor, for lowest reflected power reading. The loop is the easier to change. Filing it to reduce its width will increase its impedance. Increasing the cross-section of the loop will lower the impedance, and this can be done by coating it with solder. When the reflected

power reading is reduced as far as possible, reverse the probe and calibrate for forward power by increasing the transmitter power output in steps and making a graph of the meter readings obtained. Use the calibration control, R3, to set the maximum reading.

### Variations

Rather than to use one sampler for monitoring both forward and reflected power by repeatedly reversing the probe, it is better to make two assemblies by mounting two T fittings end-to-end, using one for forward and one for reflected power. The meter can be switched between the probes, or two meters can be used.

The sampler described was calibrated at 146 MHz, as it was intended for repeater use. On higher bands the meter reading will be higher for a given power level, and it will be lower for lower frequency bands. Calibration for two or three adjacent bands can be achieved by making the probe depth adjustable, with stops or marks to aid in resetting for a given band. Of course more probes can be made, with each probe calibrated for a given band, as is done in some of the commercially available units.

Other sizes of pipe and fittings can be used by making use of information given in [Chapter 24](#) to select conductor sizes required for the desired impedances. (Since it is occasionally possible to pick up good bargains in 75- $\Omega$  line, a sampler for this impedance might be desirable.)

Type-N fittings were used because of their constant impedance and their ease of assembly. Most have the splitting retainer, which is simple to use in this application. Some have a crimping method, as do apparently all BNC connectors. If a fitting must be used and cannot be taken apart, drill a hole large enough to clear a soldering-iron tip in the copper-pipe outer conductor. A hole of up to  $\frac{3}{8}$ -inch diameter will have very little effect on the operation of the sampler.

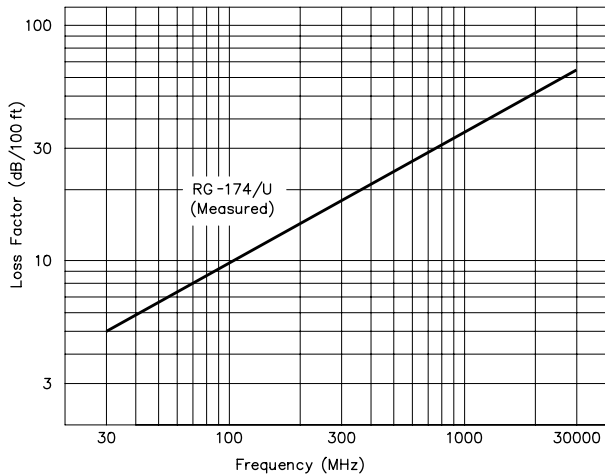
## A Calorimeter For VHF And UHF Power Measurements

A quart of water in a Styrofoam ice bucket, a roll of small coaxial cable and a thermometer are all the necessary ingredients for an accurate RF wattmeter. Its calibration is independent of frequency. The wattmeter works on the calorimeter principle: A given amount of RF energy is equivalent to an amount of heat, which can be determined by measuring the temperature rise of a known quantity of thermally insulated material. This principle is used in many of the more accurate high-power wattmeters. This procedure was developed by [James Bowen, WA4ZRP](#), and was first described in December 1975 *QST*.

The roll of coaxial cable serves as a dummy load to convert the RF power into heat. RG-174 cable was chosen for use as the dummy load in this calorimeter because of its high loss factor, small size, and low cost. It is a standard

50- $\Omega$  cable of approximately 0.11 inch diameter. A prepackaged roll marked as 60 feet long, but measured to be 68 feet, was purchased at a local electronics store. A plot of measured RG-174 loss factor as a function of frequency is shown in [Fig 25](#).

In use, the end of the cable not connected to the transmitter is left open-circuited. Thus, at 50 MHz, the reflected wave returning to the transmitter (after making a round trip of 136 feet through the cable) is  $6.7 \text{ dB} \times 1.36 = 9.11 \text{ dB}$  below the forward wave. A reflected wave 9.11 dB down represents an SWR to the transmitter of 2.08:1. While this value seems larger than would be desired, keep in mind that most 50-MHz transmitters can be tuned to match into an SWR of this magnitude efficiently. To assure accurate results, merely tune the transmitter for maximum power into



**Fig 25—Loss factor of RG-174 coax used in the calorimeter.**

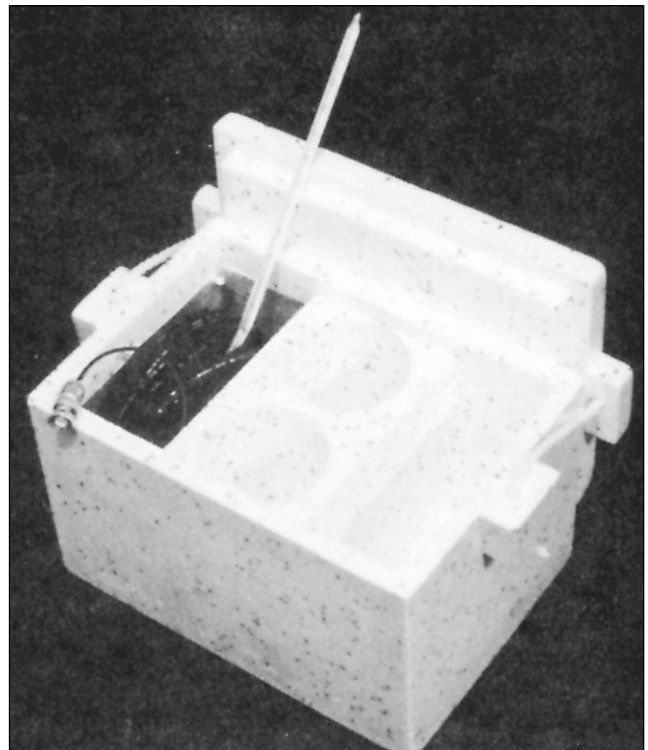
**Table 4  
Calculated Input SWR for 68 Feet of Unterminated RG-174 Cable**

Freq. (MHz)	SWR
50	2.08
144	1.35
220	1.20
432	1.06
1296	1.003
2304	1.0003

the load before making the measurement. At higher frequencies the cable loss increases so the SWR goes down. **Table 4** presents the calculated input SWR values at several frequencies for 68 feet of RG-174. At 1000 MHz and above, the SWR caused by the cable connector will undoubtedly exceed the very low cable SWR listed for these frequencies.

In operation, the cable is submerged in a quart of water and dissipated heat energy flows from the cable into the water, raising the water temperature. See **Fig 26**. The calibration of the wattmeter is based on the physical fact that one calorie of heat energy will raise one gram of liquid water 1° Celsius. Since one quart of water contains 946.3 grams, the transmitter must deliver 946.3 calories of heat energy to the water to raise its temperature 1° C. One calorie of energy is equivalent to 4.186 joules and a joule is equal to 1 W for 1 second. Thus, the heat capacitance of 1 quart of water expressed in joules is  $946.3 \times 4.186 = 3961$  joules/° C.

The heat capacitance of the cable is small with respect to that of the water, but nevertheless its effect should be included for best accuracy. The heat capacitance of the cable was determined in the manner described below. The 68-foot roll of RG-174 cable was raised to a uniform temperature of 100° C by immersing it in a pan of boiling water for several



**Fig 26—The calorimeter ready for use. The roll of coaxial cable is immersed in one quart of water in the left-hand compartment of the Styrofoam container. Also shown is the thermometer, which doubles as a stirring rod.**

minutes. A quart of tap water was poured into the Styrofoam ice bucket and its temperature was measured at 28.7° C. the cable was then transferred quickly from the boiling water to the water in the ice bucket. After the water temperature in the ice bucket had ceased to rise, it measured 33.0° C. Since the total heat gained by the quart of water was equal to the total heat lost from the cable, we can write the following equation:

$$(\Delta T_{\text{WATER}})(C_{\text{WATER}}) = -(\Delta T_{\text{CABLE}})(C_{\text{CABLE}})$$

where

$\Delta T_{\text{WATER}}$  = the change in water temperature

$C_{\text{WATER}}$  = the water heat capacitance

$\Delta T_{\text{CABLE}}$  = the change in cable temperature

$C_{\text{CABLE}}$  = the cable heat capacitance

Substituting and solving:

$$(33.0 - 28.7)(3961) = -(33.0 - 100)(C_{\text{CABLE}})$$

Thus, the total heat capacitance of the water and cable in the calorimeter is  $3961 + 254 = 4215$  joules/° C. Since 1° F = 5/9° C, the total heat capacitance can also be expressed as  $4215 \times 5/9 = 2342$  joules/° F.

### Materials and Construction

The quart of water and cable must be thermally insulated to assure that no heat is gained from or lost to the surroundings. A Styrofoam container is ideal for this purpose since Styrofoam has a very low thermal conductivity and a very low thermal capacitance. A local variety store was the

source of a small Styrofoam cold chest with compartments for carrying sandwiches and drink cans. The rectangular compartment for sandwiches was found to be just the right size for holding the quart of water and coax.

The thermometer can be either a Celsius or Fahrenheit type, but try to choose one that has divisions for each degree spaced wide enough so that the temperature can be estimated readily to one-tenth degree. Photographic supply stores carry darkroom thermometers, which are ideal for this purpose. In general, glass bulb thermometers are more accurate than mechanical dial-pointer types.

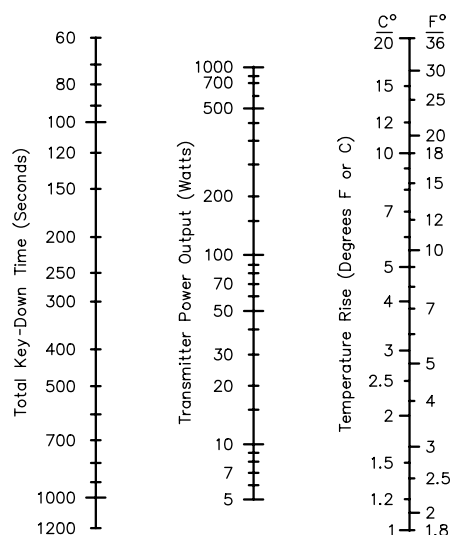
The RF connector on the end of the cable should be a constant-impedance type. A BNC type connector especially designed for use on 0.11-inch diameter cable was located through surplus channels. If you cannot locate one of these, wrap plastic electrical tape around the cable near its end until the diameter of the tape wrap is the same as that of RG-58. Then connect a standard BNC connector for RG-58 in the normal fashion. Carefully seal the opposite open end of the cable with plastic tape or silicone caulking compound so no water can leak into the cable at this point.

### Procedure for Use

Pour 1 quart of water (4 measuring cups) into the Styrofoam container. As long as the water temperature is not very hot or very cold, it is unnecessary to cover the top of the Styrofoam container during measurements. Since the transmitter will eventually heat the water several degrees, water initially a few degrees cooler than air temperature is ideal because the average water temperature will very nearly equal the air temperature and heat transfer to the air will be minimized.

Connect the RG-174 dummy load to the transmitter through the shortest possible length of lower loss cable such as RG-8. Tape the connectors and adapter at the RG-8 to RG-174 joint carefully with plastic tape to prevent water from leaking into the connectors and cable at this point. Roll the RG-174 into a loose coil and submerge it in the water. Do not bind the turns of the coil together in any way, as the water must be able to freely circulate among the coaxial cable turns. All the RG-174 cable must be submerged in the water to ensure sufficient cooling. Also submerge part of the taped connector attached to the RG-174 as an added precaution.

Upon completing the above steps, quickly tune up the transmitter for maximum power output into the load. Cease transmitting and stir the water slowly for a minute or so until its temperature has stabilized. Then measure the water temperature as precisely as possible. After the initial temperature has been determined, begin the test transmission, measuring the total number of seconds of key-down time accurately. Stir the water slowly with the thermometer and continue transmitting until there is a significant rise in the water temperature, say 5° to 10°. The test may be broken up into a series of short periods, as long as you keep track of the total key-down time. When the test is completed, continue to stir the water slowly and monitor its temperature. When the temperature ceases to rise, note the final indication as precisely as possible.



**Fig 27—Nomogram for finding transmitter power output for the calorimeter.**

To compute the transmitter power output, multiply the calorimeter heat capacitance (4215 for C or 2342 for F) by the difference in initial and final water temperature. Then divide by the total number of seconds of key-down time. The resultant is the transmitter power in watts. A nomogram that can also be used to find transmitter power output is given in **Fig 27**. With a straight line, connect the total number of key-down seconds in the time column to the number of degrees change (F or C) in the temperature rise column, and read off the transmitter power output at the point where the straight line crosses the power-output column.

### Power Limitation

The maximum power handling capability of the calorimeter is limited by the following. At very high powers the dielectric material in the coaxial line will melt because of excessive heating or the cable will arc over from excessive voltage. As the transmitter frequency gets higher, the excessive-heating problem is accentuated, as more of the power is dissipated in the first several feet of cable. For instance, at 1296 MHz, approximately 10% of the transmitting power is dissipated in the first foot of cable. Overheating can be prevented when working with high power by using a low duty cycle to reduce the average dissipated power. Use a series of short transmissions, such as two seconds on, ten seconds off. Keep count of the total key-down time for power calculation purposes. If the cable arcs over, use a larger-diameter cable, such as RG-58, in place of the RG-174. The cable should be long enough to assure that the reflected wave will be down 10 dB or more at the input. It may be necessary to use more than one quart of water in order to submerge all the cable conveniently. If so, be sure to calculate the new value of heat capacitance for the larger quantity of water. Also you should measure the new coaxial cable heat capacitance using the method previously described.

# A Noise Bridge For 1.8 Through 30 MHz

The noise bridge, sometimes referred to as an antenna (RX) noise bridge, is an instrument for measuring the impedance of an antenna or other electrical circuits. The unit shown here in **Fig 28**, designed for use in the 1.8 through 30-MHz range, provides adequate accuracy for most measurements. Battery operation and small physical size make this unit ideal for remote-location use. Tone modulation is applied to the wide-band noise generator as an aid for obtaining a null indication. A detector, such as the station receiver, is required for operation.

The noise bridge consists of two parts—the noise generator and the bridge circuitry. See **Fig 29**. A 6.8-V Zener diode serves as the noise source. U1 generates an approximate 50% duty cycle, 1000-Hz square wave signal which is applied to the cathode of the Zener diode. The 1000-Hz modulation appears on the noise signal and provides a useful null detection enhancement effect. The broadband-noise signal is amplified by Q1, Q2 and associated components to a level that produces an approximate S9 signal in the receiver. Slightly more noise is available at the lower end of the frequency range, as no frequency compensation is applied to the amplifier. Roughly 20 mA of current is drawn from the 9-V battery, thus ensuring long battery life—providing the power is switched off after use!

The bridge portion of the circuit consists of T1, C1, C2 and R1. T1 is a trifilar wound transformer with one of the windings used to couple noise energy into the bridge circuit. The remaining two windings are arranged so that each one is in an arm of the bridge. C1 and R1 complete one arm and the UNKNOWN circuit, along with C2, comprise the remainder of the bridge. The terminal labeled RCVR is for connection to the detector.

The reactance range of a noise bridge is dependent on several factors, including operating frequency, value of the series capacitor (C3 or C3 plus C4 in **Fig 29**) and the range of the variable capacitor (C1 in **Fig 29**). The RANGE switch selects reactance measurements weighted toward either capacitance or inductance by placing C4 in parallel with C3.

The zero-reactance point occurs when C1 is either nearly fully meshed or fully unmeshed. The RANGE switch nearly doubles the resolution of the reactance readings.

## CONSTRUCTION

The noise bridge is contained in a homemade aluminum enclosure that measures  $5 \times 2\frac{3}{8} \times 3\frac{3}{4}$  inches. Many of the circuit components are mounted on a circuit board that is fastened to the rear wall of the cabinet. The circuit-board layout is such that the lead lengths to the board from the bridge and coaxial connectors are at a minimum. An etching pattern and a parts-placement guide for the circuit board are shown in **Figs 30** and **31**.

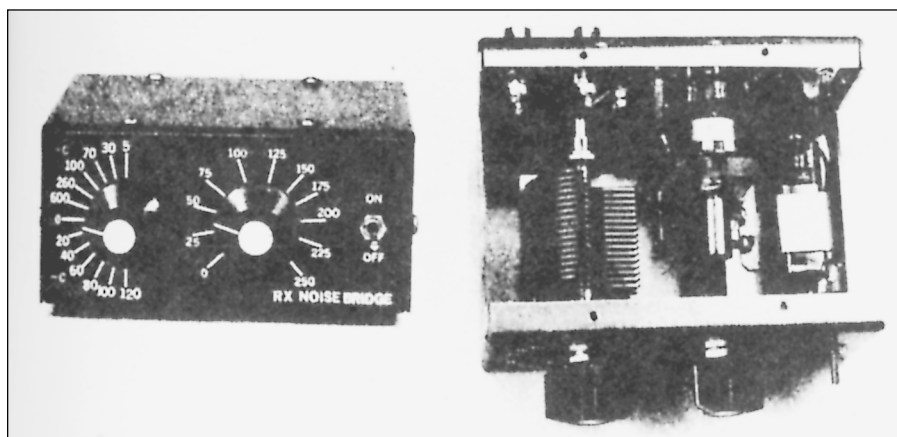
Care must be taken when mounting the potentiometer, R1. For accurate readings the potentiometer must be well insulated from ground. In the unit shown this was accomplished by mounting the control on a piece of plexiglass, which in turn was fastened to the chassis with a piece of aluminum angle stock.

Additionally, a  $\frac{1}{4}$ -inch control-shaft coupling and a length of phenolic rod were used to further isolate the control from ground where the shaft passes through the front panel. A high-quality potentiometer is required if good measurement results are to be obtained.

There is no such problem when mounting the variable capacitor because the rotor is grounded. Use a high-quality capacitor; do not try to save money on that component. Two RF connectors on the rear panel are connected to a detector (receiver) and to the UNKNOWN circuit. Do not use plastic-insulated phono connectors (they might influence bridge accuracy at higher frequencies). Use miniature coaxial cable (RG-174) between the RCVR connector and circuit board. Attach one end of C3 to the circuit board and the other directly to the UNKNOWN circuit connector.

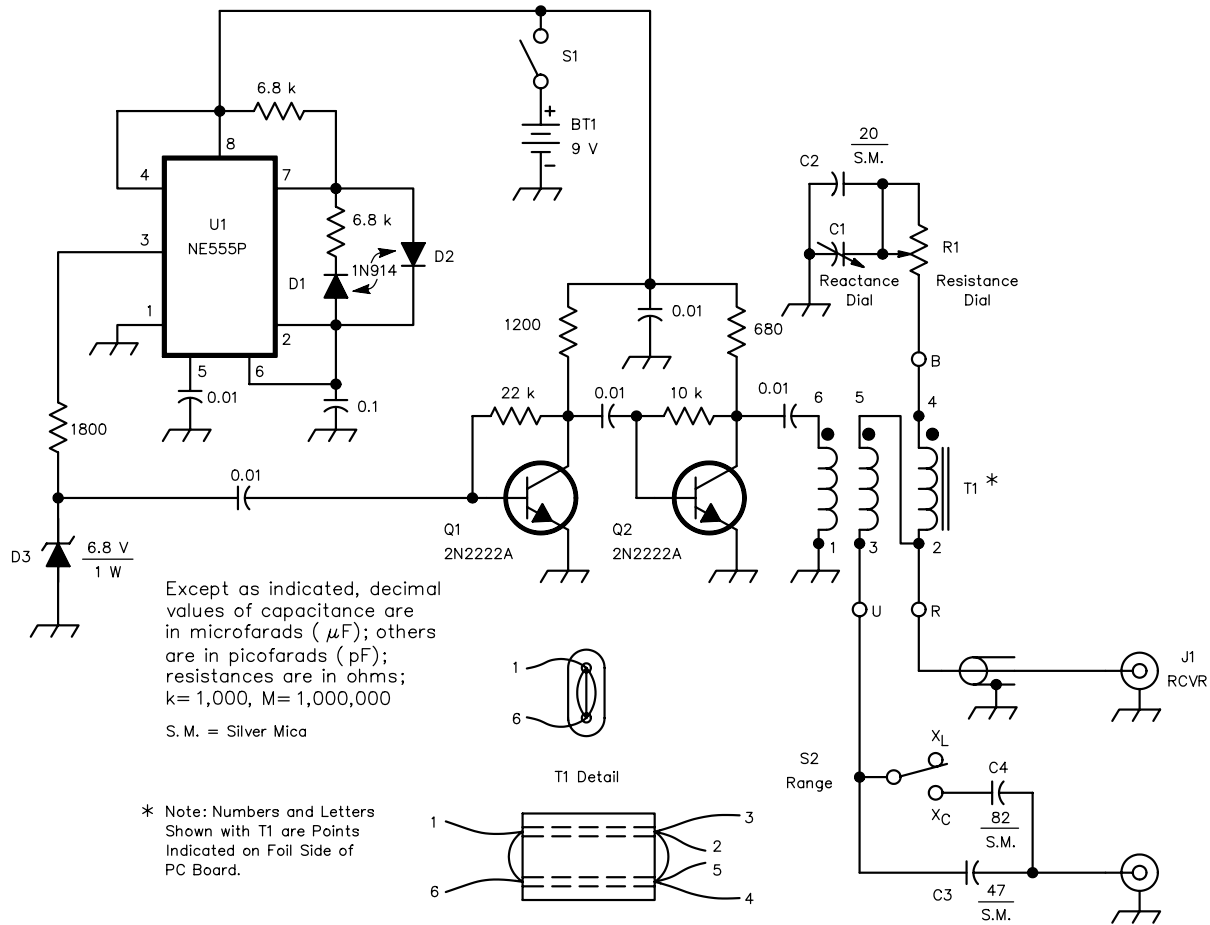
## Bridge Compensation

Stray capacitance and inductance in the bridge circuit can affect impedance readings. If a very accurate bridge is



**Fig 28**—Exterior and interior views of the noise bridge. The unit is finished in red enamel. Press-on lettering is used for the calibration marks. Note that the potentiometer must be isolated from ground.

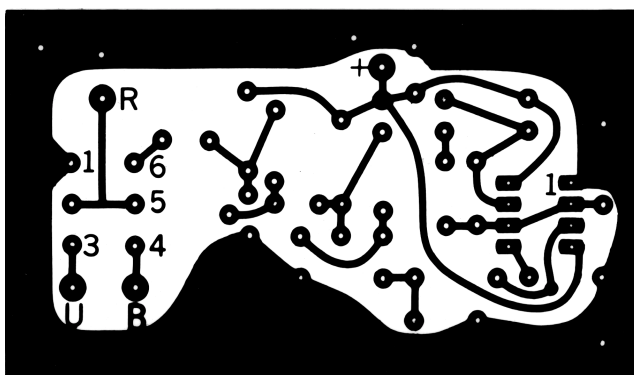




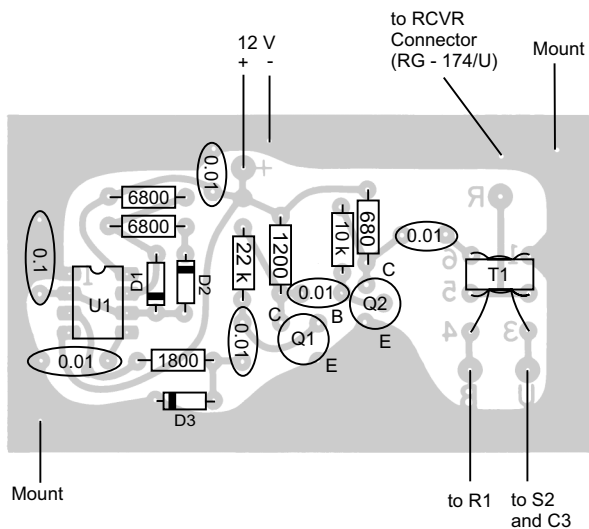
**Fig 29—Schematic diagram of the noise bridge. Use 1/4-W composition resistors. Capacitors are miniature ceramic units unless indicated otherwise. Component designations indicated in the schematic but not called out in the parts list are for text and parts-placement reference only.**

- BT1—9-V battery, NEDA 1604A or equiv.
- C1—15- to 150-pF variable
- C2—20-pF mica.
- C3—47-pF mica.
- C4—82-pF mica.
- J1, J2—Coaxial connector.
- R1—Linear, 250  $\Omega$ , AB type. Use a good grade of resistor.
- S1, S2—Toggle, SPST.

- T1—Transformer; 3 windings on an Amidon BLN-43-2402 ferrite binocular core. Each winding is three turns of #30 enameled wire. One turn is equal to the wire passing once through both holes in the core. The primary winding starts on one side of the transformer, and the secondary and tertiary windings start on the opposite side.
- U1—Timer, NE555 or equiv.



**Fig 30—Etching pattern for the noise bridge PC board, at actual size. Black represents copper. This is the pattern for the bottom side of the board. The top side of the board is a complete ground plane with a small amount of copper removed from around the component holes.**



**Fig 31—Parts-placement guide for the noise bridge as viewed from the component or top side of the board. Mounting holes are located in two corners of the board, as shown.**

required, use the following steps to counter the effects of stray reactance. Because the physical location of the board, connectors and controls in the cabinet determine where compensation is needed, there is no provision for the compensation components on the printed circuit board.

Good calibration loads are necessary to check the accuracy of the noise bridge. Four are needed here: a 0-Ω (short-circuit) load, a 50-Ω load, a 180-Ω load, and a variable-resistance load. The short-circuit and fixed-resistance loads are used to check the accuracy of the noise bridge; the variable-resistance load is used when measuring coaxial-cable loss.

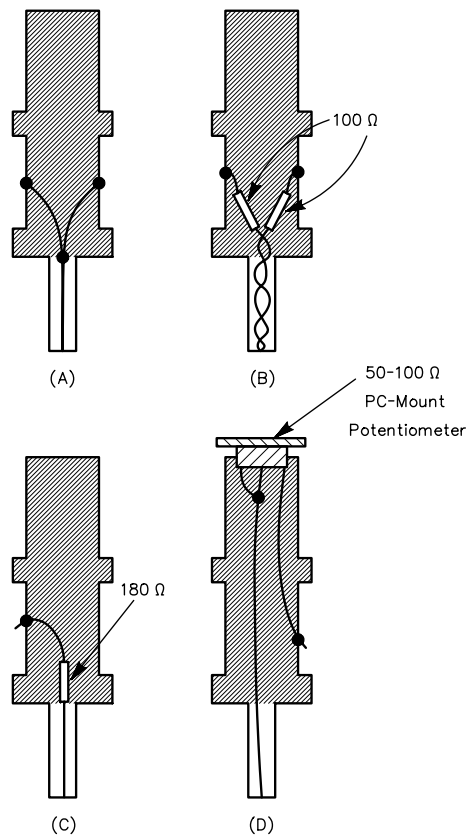
Construction details of the loads are shown in **Fig 32**. Each load is constructed inside a connector. When building the loads, keep leads as short as possible to minimize parasitic effects. The resistors must be noninductive (*not* wirewound).

Quarter-watt, carbon-composition resistors should work fine. The potentiometer in the variable-resistance load is a miniature PC-mount unit with a maximum resistance of 100 Ω or less. The potentiometer wiper and one of the end leads are connected to the center pin of the connector; the other lead is connected to ground.

### Stray Capacitance

Stray capacitance on the variable-resistor side of the bridge tends to be higher than that on the unknown side. This is so because the parasitic capacitance in the variable resistor, R1, is comparatively high.

The effect of parasitic capacitance is most easily detected using the 180-Ω load. Measure and record the actual resistance of the load, R<sub>L</sub>. Connect the load to the



**Fig 32—Construction details of the resistive loads used to check and calibrate the noise bridge. Each of the loads is constructed inside a coaxial connector that matches those on the bridge. (Views shown are cross-sections of PL-259 bodies; the sleeves are not shown.) Leads should be kept as short as possible to minimize parasitic inductance. A is a 0-Ω load; B depicts a 50-Ω load; C is a 180-Ω load; D shows a variable-resistance load used to determine the loss in a coaxial cable.**

UNKNOWN connector, place S2 in the X<sub>L</sub> position, tune the receiver to 1.8 MHz, and null the bridge. (See the section, “Finding the Null” for tips.) Use an ohmmeter across R1 to measure its dc resistance. The magnitude of the stray capacitance can be calculated by

$$C_p = C3 \left( \sqrt{\frac{R1}{R2}} - 1 \right) \quad (\text{Eq 4})$$

where

- R<sub>L</sub> = load resistance (as measured)
- R1 = resistance of the variable resistor
- C3 = series capacitance.

You can compensate for C<sub>p</sub> by placing a variable capacitor, C<sub>C</sub>, in the side of the bridge with lesser stray capacitance. If R1 is greater than R<sub>L</sub>, stray capacitance is greater on the variable resistor side of the bridge: Place C<sub>C</sub> between point U (on the circuit board) and ground. If R1 is less than R<sub>L</sub>, stray capacitance is greater on the unknown

side: Place  $C_C$  between point B and ground. If the required compensating capacitance is only a few picofarads, you can use a gimmick capacitor (made by twisting two short pieces of insulated, solid wire together) for  $C_C$ . A gimmick capacitor is adjusted by trimming its length.

### Stray Inductance

Parasitic inductance, if present, should be only a few tens of nanohenries. This represents a few ohms of inductive reactance at 30 MHz. The effect is best observed by reading the reactance of the 0- $\Omega$  test load at 1.8 and 30 MHz; the indicated reactance should be the same at both frequencies.

If the reactance reading decreases as frequency is increased, parasitic inductance is greater in the known arm, and compensating inductance is needed between point U and C3. If the reactance increases with frequency, the unknown-arm inductance is greater, and compensating inductance should be placed between point B and R1.

Compensate for stray inductance by placing a single-turn coil, made from a 1 to 2-inch length of solid wire, in the appropriate arm of the bridge. Adjust the size of this coil until the reactance reading remains constant from 1.8 to 30 MHz.

### Calibration

Good calibration accuracy is necessary for accurate noise-bridge measurements. Calibration of the resistance scale is straightforward. To do this, tune the receiver to a frequency near 10 MHz. Attach the 0- $\Omega$  load to the UNKNOWN connector and null the bridge. This is the zero-resistance point; mark it on the front-panel resistance scale. The rest of the resistance range is calibrated by adjusting R1, measuring R1 with an accurate ohmmeter, calculating the increase from the zero point and marking the increase on the front panel.

Most bridges have the reactance scale marked in capacitance because capacitance does not vary with frequency. Unfortunately, that requires calibration curves or non-trivial calculations to arrive at the load reactance. An alternative method is to mark the reactance scale in *ohms* at a reference frequency of 10 MHz. This method calibrates the bridge near the center of its range and displays reactance directly, but it requires a simple calculation to scale the reactance reading for frequencies other than 10 MHz. The scaling equation is:

$$X_{u(f)} = X_{u(10)} \frac{10}{f} \quad (\text{Eq 5})$$

where

$f$  = frequency in MHz

$X_{u(10)}$  = reactance of the unknown load at 10 MHz

$X_{u(f)}$  = reactance of the unknown load at  $f$ .

A shorted piece of coaxial cable serves as a reactance source. (The reactance of a shorted, low-loss coaxial cable is dependent only on the cable length, the measurement frequency and the cable characteristic impedance.) Radio

Shack RG-8M is used here because it is readily available, has relatively low loss and has an almost purely resistive characteristic impedance.

Prepare the calibration cable as follows:

- 1) Cut a length of coaxial cable that is slightly longer than  $\frac{1}{4} \lambda$  at 10 MHz (about 20 feet for RG-8M). Attach a suitable connector to one end of the cable; leave the other end open-circuited.
- 2) Connect the 0- $\Omega$  load to the noise bridge UNKNOWN connector and set the receiver frequency to 10 MHz. Adjust the noise bridge for a null. Do not adjust the reactance control after the null is found.
- 3) Connect the calibration cable to the bridge UNKNOWN terminal. Null the bridge by adjusting *only* the variable resistor and the receiver frequency. The receiver frequency should be less than 10 MHz; if it is above 10 MHz, the cable is too short, and you need to prepare a longer one.
- 4) Gradually cut short lengths from the end of the coaxial cable until you obtain a null at 10 MHz by adjusting only the resistance control. Then connect the cable center and shield conductors at the open end with a short length of braid. Verify that the bridge nulls with zero reactance at 20 MHz.
- 5) The reactance of the coaxial cable (normalized to 10 MHz) can be calculated from:

$$X_{i(10)} = R_0 \frac{f}{10} \tan \left( 2\pi \frac{f}{40} \right) \quad (\text{Eq 6})$$

where

$X_{i(10)}$  = cable reactance at 10 MHz

$R_0$  = characteristic resistance of the coaxial cable  
(52.5  $\Omega$  for Radio Shack RG-8M)

$f$  = frequency in MHz

The results of Eq 6 have less than 5% error for reactances less than 500  $\Omega$ , so long as the test-cable loss is less than 0.2 dB. This error becomes significantly less at lower reactances (2% error at 300  $\Omega$  for a 0.2-dB-loss cable). The loss in 18 feet of RG-8M is 0.13 dB at 10 MHz. Reactance data for Radio Shack RG-8M is given in [Table 5](#).

With the prepared cable and calibration values on hand, proceed to calibrate the reactance scale. Tune the receiver to the appropriate frequency for the desired reactance (given in [Table 5](#), or found using Eq 6). Adjust the resistance and reactance controls to null the bridge. Mark the reactance reading on the front panel. Repeat this process until all desired reactance values have been marked. The resistance values needed to null the bridge during this calibration procedure may be significant (more than 100  $\Omega$ ) at the higher reactances.

This calibration method is much more accurate than using fixed capacitors across the UNKNOWN connector. Also, you can calibrate a noise bridge in less than an hour using this method.

**Table 5**  
**Noise Bridge Calibration Data: Coaxial-Cable Method**

*This data is for Radio Shack RG-8M cable ( $R_0 = 52.5 \Omega$ ) cut to exactly  $1/4 \lambda$  at 10 MHz; the reactances and capacitances shown correspond to this frequency.*

Reactance				Capacitance	
$X_i$	$f(\text{MHz})$	$X_i$	$f(\text{MHz})$	$C(\text{pF})$	$f(\text{MHz})$
10	3.318	-10	19.376	10	9.798
20	4.484	-20	18.722	20	9.612
30	5.262	-30	18.048	30	9.440
40	5.838	-40	17.368	40	9.280
50	6.286	-50	16.701	50	9.130
60	6.647	-60	16.062	60	8.990
70	6.943	-70	15.471	70	8.859
80	7.191	-80	14.936	80	8.735
90	7.404	-90	14.462	90	8.618
100	7.586	-100	14.044	100	8.508
110	7.747	-110	13.682	110	8.403
120	7.884	-120	13.369	120	8.304
130	8.009	-130	13.097	130	8.209
140	8.119	-140	12.861	140	8.119
150	8.217	-150	12.654		
160	8.306	-160	12.473		
170	8.387	-170	12.313		
180	8.460	-180	12.172		
190	8.527	-190	12.045		
200	8.588	-200	11.932	$C(\text{pF})$	$f(\text{MHz})$
210	8.645	-210	11.831	-10	10.219
220	8.697	-220	11.739	-20	10.459
230	8.746	-230	11.655	-30	10.721
240	8.791	-240	11.579	-40	11.010
250	8.832	-250	11.510	-50	11.328
260	8.872	-260	11.446	-60	11.679
270	8.908	-270	11.387	-70	12.064
280	8.942	-280	11.333	-80	12.484
290	8.975	-290	11.283	-90	12.935
300	9.005	-300	11.236	-100	13.407
350	9.133	-350	11.045	-110	13.887
400	9.232	-400	10.905	-120	14.357
450	9.311	-450	10.798	-130	14.801
500	9.375	-500	10.713	-140	15.211

### Finding the Null

In use, a receiver is attached to the RCVR connector and some load of unknown value is connected to the UNKNOWN terminal. The receiver allows us to hear the noise present across the bridge arms at the frequency of the receiver passband. The strength of the noise signal depends on the strength of the noise-bridge battery, the receiver bandwidth/sensitivity and the impedance difference between the known and unknown bridge arms. The noise is stronger and the null more obvious with wide receiver passbands. Set the receiver to the widest bandwidth AM mode available.

The noise-bridge output is heard as a 1000-Hz tone. When the impedances of the known and unknown bridge

arms are equal, the voltage across the receiver is minimized; this is a null. In use, the null may be difficult to find because it appears only when both bridge controls approach the values needed to balance the bridge.

To find the null, set C1 to mid-scale, sweep R1 slowly through its range and listen for a reduction in noise (it's also helpful to watch the S meter). If no reduction is heard, set R1 to mid-range and sweep C1. If there is still no reduction, begin at one end of the C1 range and sweep R1. Increment C1 about 10% and sweep R1 with each increment until some noise reduction appears. Once noise reduction begins, adjust C1 and R1 alternately for minimum signal.

### MEASURING COAXIAL-CABLE PARAMETERS WITH A NOISE BRIDGE

Coaxial cables have a number of properties that affect the transmission of signals through them. Generally, radio amateurs are concerned with cable attenuation and characteristic impedance. If you plan to use a noise bridge or SWR analyzer to make antenna-impedance measurements, however, you need to accurately determine not just cable impedance and attenuation, but also electrical length. Fortunately, all of these parameters are easy to measure with an accurate noise bridge or SWR analyzer.

#### Cable Electrical Length

With a noise bridge and a general-coverage receiver, you can easily locate frequencies at which the line in question is a multiple of  $1/2 \lambda$ , because a shorted  $1/2 \lambda$  line has a  $0-\Omega$  impedance (neglecting line loss). By locating two adjacent null frequencies, you can solve for the length of line in terms of  $1/2 \lambda$  at one of the frequencies and calculate the line length (overall accuracy is limited by bridge accuracy and line loss, which broadens the nulls). As an interim variable, you can express cable length as the frequency at which a cable is  $1 \lambda$  long. This length will be represented by  $f \lambda$ . Follow these steps to determine  $f \lambda$  for a coaxial cable.

- 1) Tune the receiver to the frequency range of interest. Attach the short-circuit load to the noise bridge UNKNOWN connector and null the bridge.
- 2) Disconnect the far end of the coaxial cable from its load (the antenna) and connect it to the  $0-\Omega$  test load. Connect the near end of the cable to the bridge UNKNOWN connector.
- 3) Adjust the receiver frequency and the noise-bridge resistance control for a null. *Do not change the noise bridge reactance-control setting during this procedure.* Note the frequency at which the null is found; call this frequency  $f_n$ . The noise-bridge resistance at the null should be relatively small (less than  $20 \Omega$ ).
- 4) Tune the receiver upward in frequency until the next null is found. Adjust the resistance control, if necessary, to improve the null, *but do not adjust the reactance control.* Note the frequency at which this second null is found; this is  $f_{n+2}$ .
- 5) Solve Eq 7 for n and the electrical length of the cable.

$$n = \frac{2f_n}{f_n + 2 - f_n} \quad (\text{Eq 7})$$

$$f_\lambda = \frac{4f_n}{n} \quad (\text{Eq 8})$$

where

$n$  = cable electrical length in quarter waves, at  $f_n$

$f_1$  = frequency at which the cable is  $1\lambda$

$\ell$  = cable electrical length, in  $\lambda$

For example, consider a 74-foot length of Columbia 1188 foam-dielectric cable (velocity factor = 0.78) to be used on the 10-meter band. Based on the manufacturer's specification, the cable is 2.796  $\lambda$  at 29 MHz. Nulls were found at 24.412 ( $f_n$ ) and 29.353 ( $f_{n+2}$ ) MHz. Eq 7 yields  $n = 9.88$ , which produces 9.883 MHz from Eq 8 and 2.934  $\lambda$  for Eq 9. If the manufacturer's specification is correct, the measured length is off by less than 5%, which is very reasonable. Ideally,  $n$  would yield an integer. The difference between  $n$  and the closest integer indicates that there is some error.

This procedure also works for lines with an open circuit as the termination ( $n$  will be close to an odd number). End effects from the PL-259 increase the effective length of the coaxial cable; however, this decreases the calculated  $f_\lambda$ .

### Cable Characteristic Impedance

The characteristic impedance of the coaxial cable is found by measuring its input impedance at two frequencies separated by  $1/4 f_\lambda$ . This must be done when the cable is terminated in a resistive load.

Characteristic impedance changes slowly as a function of frequency, so this measurement must be done near the frequency of interest. The measurement procedure is as follows.

- 1) Place the 50- $\Omega$  load on the far end of the coaxial cable and connect the near end to the UNKNOWN connector of the noise bridge. (Measurement error is minimized when the load resistance is close to the characteristic impedance of the cable. This is the reason for using the 50- $\Omega$  load.)
- 2) Tune the receiver approximately  $1/8 f$  below the frequency of interest. Adjust the bridge resistance and reactance controls to obtain a null, and note their readings as  $R_{f1}$  and  $X_{f1}$ . Remember, the reactance reading must be scaled to the measurement frequency.
- 3) Increase the receiver frequency by exactly  $1/4 f\lambda$ . Null the bridge again, and note the readings as  $R_{f2}$  and  $X_{f2}$ .
- 4) Calculate the characteristic impedance of the coaxial cable using Eqs 10 through 15. A scientific calculator is helpful for this.

$$R = R_{f1} \times F_{f2} - X_{f1} \times X_{f2} \quad (\text{Eq 10})$$

$$X = R_{f1} \times X_{f2} + X_{f1} \times R_{f2} \quad (\text{Eq 11})$$

$$Z = \sqrt{R^2 + X^2} \quad (\text{Eq 12})$$

$$R_0 = \sqrt{Z} \cos \left[ \frac{1}{2} \tan^{-1} \left( \frac{X}{R} \right) \right] \quad (\text{Eq 13})$$

$$X_0 = \sqrt{Z} \sin \left[ \frac{1}{2} \tan^{-1} \left( \frac{X}{R} \right) \right] \quad (\text{Eq 14})$$

$$Z_0 = R_0 + jX_0 \quad (\text{Eq 15})$$

Let's continue with the example used earlier for cable length. The measurements are:

$$f1 = 29.000 - (9.883 / 8) = 27.765 \text{ MHz}$$

$$R_{f1} = 64 \Omega$$

$$X_{f1} = -22 \Omega \times (10 / 27.765) = -7.9 \Omega$$

$$f2 = 27.765 + (9.883/4) = 30.236 \text{ MHz}$$

$$R_{f2} = 50 \Omega$$

$$X_{f2} = -24 \Omega \times (10 / 30.236) = -7.9 \Omega$$

When used in Eqs 10 through 15, these data yield:

$$R = 3137.59$$

$$X = -900.60$$

$$Z = 3264.28$$

$$R_0 = 56.58 \Omega$$

$$X_0 = -7.96 \Omega$$

### Cable Attenuation

Cable loss can be measured once the cable electrical length and characteristic resistance are known. The measurement must be made at a frequency where the cable presents no reactance. Reactance is zero when the cable electrical length is an integer multiple of  $\lambda/4$ . You can easily meet that condition by making the measurement frequency an integer multiple of  $1/4 f\lambda$ . Loss at other frequencies can be interpolated with reasonable accuracy. This procedure employs a resistor-substitution method that provides much greater accuracy than is achieved by directly reading the resistance from the noise-bridge scale.

- 1) Determine the approximate frequency at which you want to make the loss measurement by using

$$n = \frac{4f_0}{f_\lambda} \quad (\text{Eq 16A})$$

Round  $n$  to the nearest integer, then

$$f1 = \frac{n}{4} f_\lambda \quad (\text{Eq 16B})$$

- 2) If  $n$  is odd, leave the far end of the cable open; if  $n$  is even, connect the 0- $\Omega$  load to the far end of the cable. Attach the near end of the cable to the UNKNOWN connector on the noise bridge.
- 3) Set the noise bridge to zero reactance and the receiver to  $f1$ . Fine tune the receiver frequency and the noise-bridge resistance to find the null.
- 4) Disconnect the cable from the UNKNOWN terminal, and connect the variable-resistance calibration load in its place. Without changing the resistance setting on the bridge, adjust the load resistor and the bridge reactance to obtain a null.

- 5) Remove the variable-resistance load from the bridge UNKNOWN terminal and measure the load resistance using an ohmmeter that's accurate at low resistance levels. Refer to this resistance as  $R_i$ .
- 6) Calculate the cable loss in decibels using

$$al = 8.69 \frac{R_i}{R_0} \quad (\text{Eq 17})$$

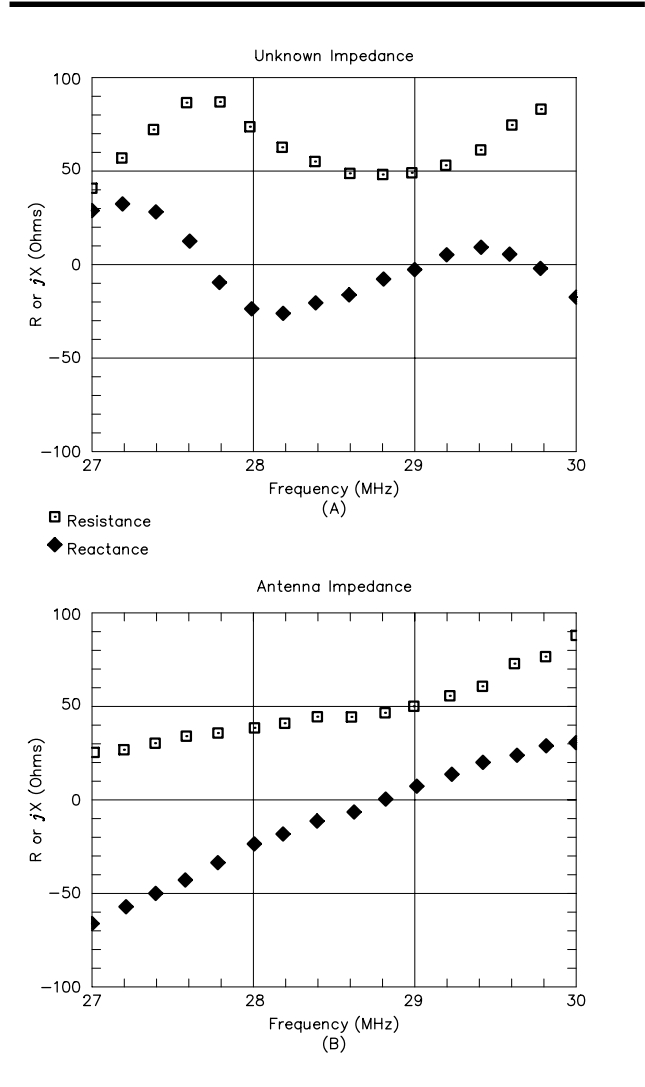
To continue this example, Eq 16A gives  $n = 11.74$ , so measure the attenuation at  $n = 12$ . From Eq 16B,  $f_1 = 29.649$  MHz. The input resistance of the cable measures  $12.1 \Omega$  with  $0\text{-}\Omega$  load on the far end of the cable; this corresponds to a loss of 1.86 dB.

### USING A BRIDGE TO MEASURE THE IMPEDANCE OF AN ANTENNA

The impedance at the end of a transmission line can be easily measured using a noise bridge or SWR analyzer. In many cases, however, you really want to measure the impedance of an antenna—that is, the impedance of the load at the far end of the line. There are several ways to handle this.

- 1) Measurements can be made with the bridge at the antenna. This is usually not practical because the antenna must be in its final position for the measurement to be accurate. Even if it can be done, making such a measurement is certainly not very convenient.
- 2) Measurements can be made at the source end of a coaxial cable—if the cable length is an exact integer multiple of  $\frac{1}{2} \lambda$ . This effectively restricts measurements to a single frequency.
- 3) Measurements can be made at the source end of a coaxial cable and corrected using a Smith Chart as shown in Chapter 28. This graphic method can result in reasonable estimates of antenna impedance—as long as the SWR is not too high and the cable is not too lossy. However, it doesn't compensate for the complex impedance characteristics of real-world coaxial cables. Also, compensation for cable loss can be tricky to apply. These problems, too, can lead to significant errors.
- 4) Last, measurements can be corrected using the transmission-line equation. The *TLW* program included on the CD-ROM in the back of this book, can do these complicated computations for you. This is the best method for calculating antenna impedances from measured parameters, but it requires that you measure the feed-line characteristics beforehand—measurements for which you need access to both ends of the feed line.

The procedure for determining antenna impedance is to first measure the electrical length, characteristic impedance, and attenuation of the coaxial cable connected to the antenna. After making these measurements, connect the antenna to the coaxial cable and measure the input impedance of the cable at a number of frequencies. Then use these measurements in the transmission-line equation



**Fig 33—Impedance plot of an inverted-V antenna cut for 29 MHz. At A, a plot of resistances and reactances, measured using the noise bridge, at the end of a 74-foot length of Columbia 1188 coaxial cable. At B, the actual antenna-impedance plot (found using the transmission-line equation to remove the effects of the transmission line).**

to determine the actual antenna impedance at each frequency.

Table 6 and Fig 33 give an example of such a calculation. The antenna used for this example is a 10-meter inverted V about 30 feet above the ground. The arms of the antenna are separated by a  $120^\circ$  angle. Each arm is exactly 8 feet long, and the antenna is made of #14 wire. The feed line is the 74-foot length of Columbia 1188 characterized earlier.

See Fig 33A. From this plot of impedance measurements, it is very difficult to determine anything about the antenna. Resistance and reactance vary substantially over this frequency range, and the antenna appears to be resonant at 27.7, 29.0 and 29.8 MHz.

**Table 6**  
**Impedance Data for Inverted-V Antenna**

Freq (MHz)	$R_U$ ( $\Omega$ )	$X_U$ @ 10 MHz ( $\Omega$ )	$X_U$ ( $\Omega$ )	$R_L$ ( $\Omega$ )	$X_L$ ( $\Omega$ )
27.0	44	85	31.5	24	-65
27.2	60	95	34.9	26	-56
27.4	75	85	31.0	30	-51
27.6	90	40	14.5	32	-42
27.8	90	-20	-7.2	35	-34
28.0	75	-58	-20.7	38	-24
28.2	65	-65	-23.0	40	-19
28.4	56	-52	-18.3	44	-12
28.6	50	-40	-14.0	44	-6
28.8	48	-20	-6.9	47	1
29.0	50	0	0.0	52	8
29.2	55	20	6.8	57	15
29.4	64	30	10.2	63	21
29.6	78	20	6.8	75	26
29.8	85	0	0	78	30
30.0	90	-50	-16.7	89	33

The plot in Fig 33B shows the true antenna impedance. This plot has been corrected for the effects of the cable using the transmission-line equation. The true antenna resistance and reactance both increase smoothly with frequency. The antenna is resonant at 28.8 MHz, with a radiation resistance at resonance of 47  $\Omega$ . This is normal for an inverted V.

When doing the conversions, be careful not to make measurement errors. Such errors introduce more errors into the corrected data. This problem is most significant when the transmission line is near an odd multiple of a  $1/4 \lambda$  and the line SWR and/or attenuation is high. Measurement errors are probably present if small changes in the input impedance or transmission-line characteristics appear as large changes in antenna impedance. If this effect is present, it can be minimized by making the measurements with a transmission line that is approximately an integer multiple of  $1/2 \lambda$ .

## A Practical Time-Domain Reflectometer

A time-domain reflectometer (TDR) is a simple but powerful tool used to evaluate transmission lines. When used with an oscilloscope, a TDR displays impedance “bumps” (open and short circuits, kinks and so on) in transmission lines. Commercially produced TDRs cost from hundreds to thousands of dollars each, but you can add the TDR described here to your shack for much less. This material is based on a *QST* article by Tom King, KD5HM (see Bibliography), and supplemented with information from the references.

### How a TDR Works

A simple TDR consists of a square-wave generator and an oscilloscope. See Fig 34. The generator sends a train of

dc pulses down a transmission line, and the oscilloscope lets you observe the incident and reflected waves from the pulses (when the scope is synchronized to the pulses).

A little analysis of the scope display tells the nature and location of any impedance changes along the line. The nature of an impedance disturbance is identified by comparing its pattern to those in Fig 35. The patterns are based on the fact that the reflected wave from a disturbance is determined by the incident-wave magnitude and the reflection coefficient of the disturbance. (The patterns shown neglect losses; actual patterns may vary somewhat from those shown.)

The location of a disturbance is calculated with a simple proportional method: The round-trip time (to the disturbance) can be read from the oscilloscope screen (graticule). Thus, you need only read the time, multiply it by the velocity of the radio wave (the speed of light adjusted by the velocity factor of the transmission line) and divide by two. The distance to a disturbance is given by:

$$\ell = \frac{983.6 \times VF \times t}{2} \quad (\text{Eq 18})$$

where

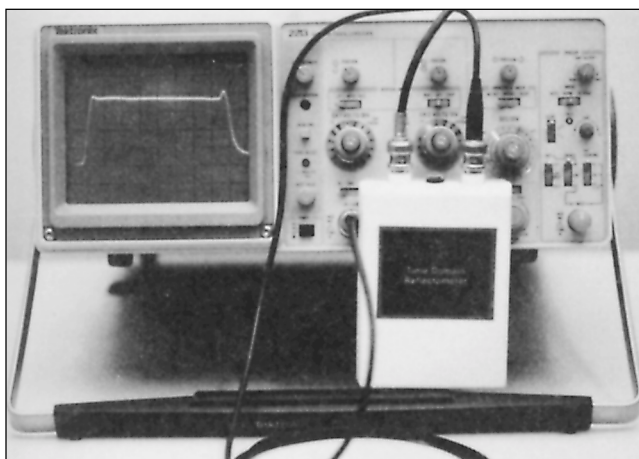
$\ell$  = line length in feet

VF = velocity factor of the transmission line (from 0 to 1.0)

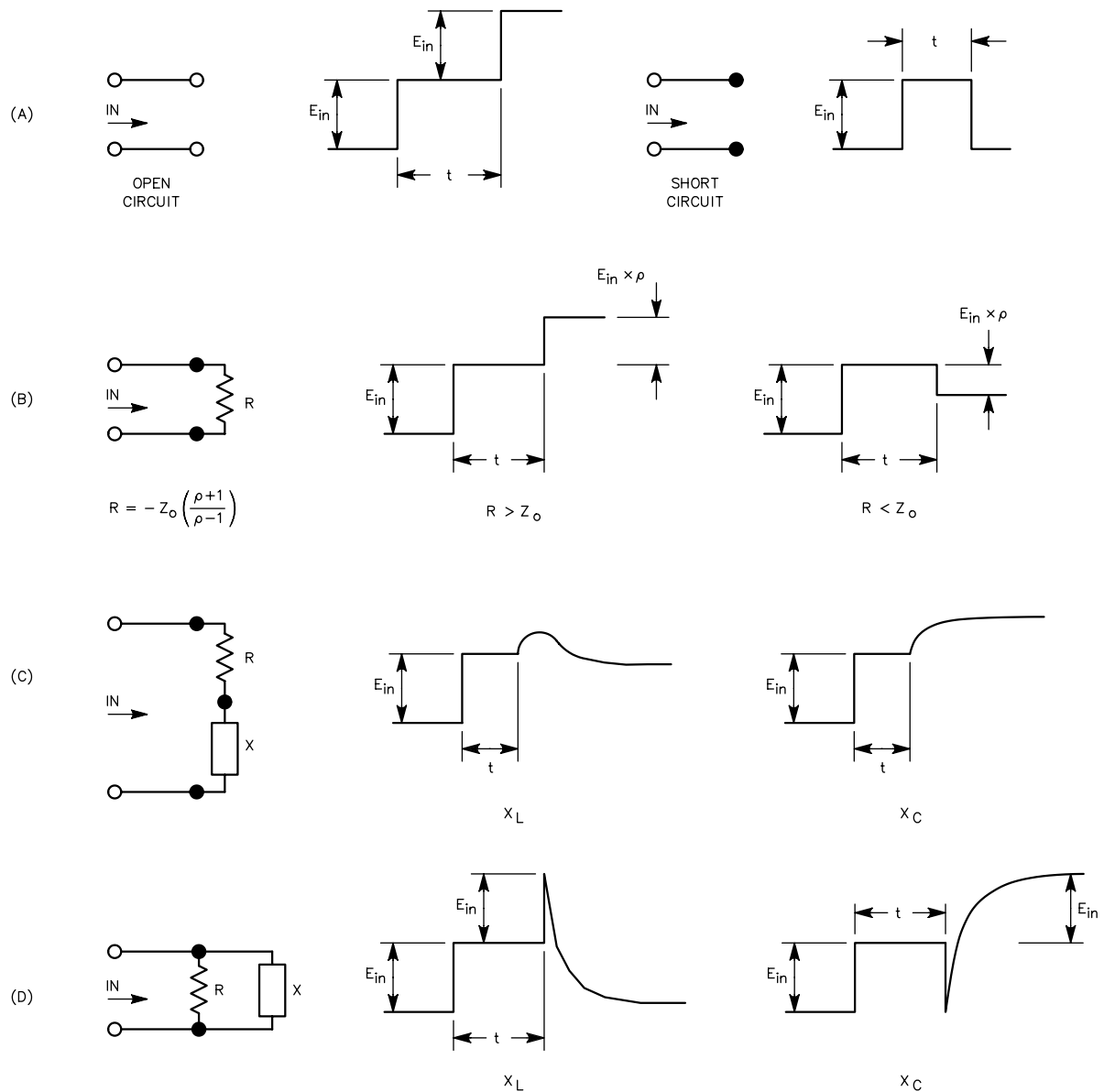
t = time delay in microseconds ( $\mu\text{s}$ ).

### The Circuit

The time-domain reflectometer circuit in Fig 36 consists of a CMOS 555 timer configured as an astable multivibrator, followed by an MPS3646 transistor acting as



**Fig 34—The time-domain reflectometer shown here is attached to a small portable oscilloscope.**



**Fig 35—Characteristic TDR patterns for various loads. The location of the load can be calculated from the transit time,  $t$ , which is read from the oscilloscope (see text).  $R$  values can be calculated as shown (for purely resistive loads only— $\rho < 0$  when  $R < Z_0$ ;  $\rho > 0$  when  $R > Z_0$ ). Values for reactive loads cannot be calculated simply.**

a 15-ns-risetime buffer. The timer provides a 71-kHz square wave. This is applied to the 50- $\Omega$  transmission line under test (connected at J2). The oscilloscope is connected to the circuit at J1.

### Construction

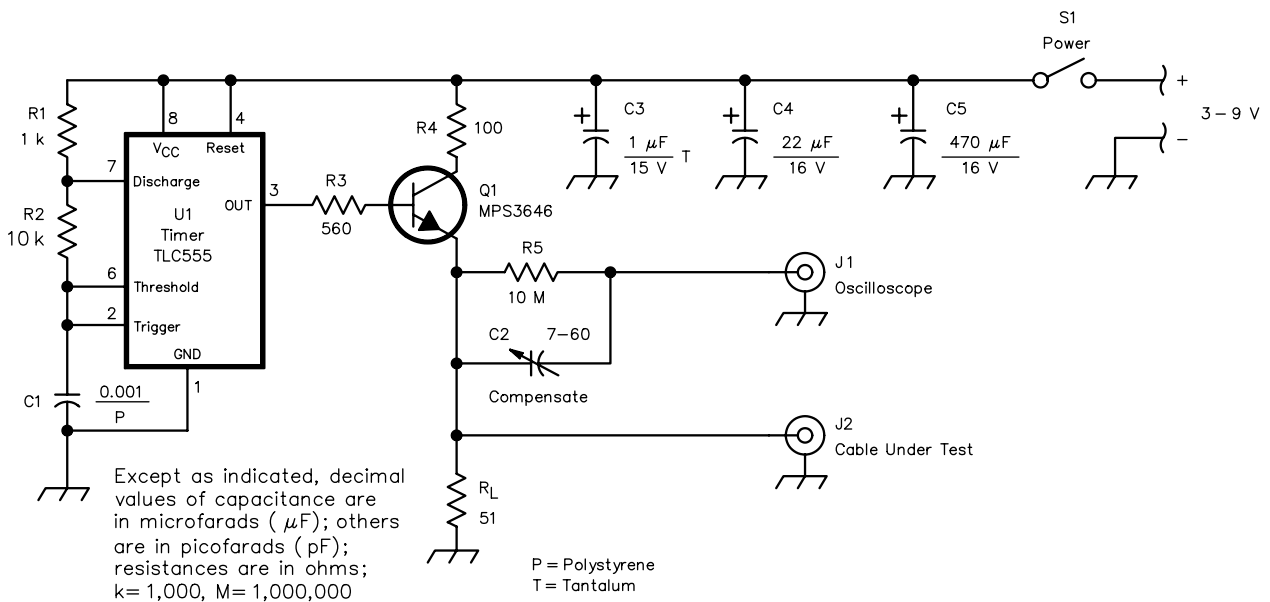
An etching pattern for the TDR is shown in Fig 37. Fig 38 is the part-placement diagram. The TDR is designed for a 4 $\times$ 3 $\times$ 1-inch enclosure (including the batteries). S1, J1 and J2 are right-angle-mounted components. Two aspects of construction are critical. First use *only* an MPS3646 for

Q1. This type was chosen for its good performance in this circuit. If you substitute another transistor, the circuit may not perform properly.

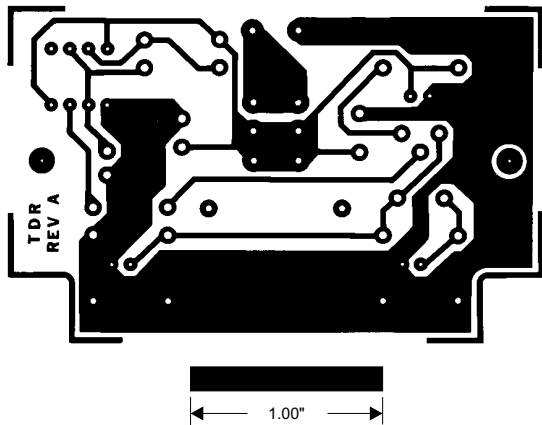
Second, for the TDR to provide accurate measurements, the cable connected to J1 (between the TDR and the oscilloscope) must not introduce impedance mismatches in the circuit. *Do not make this cable from ordinary coaxial cable.* Oscilloscope-probe cable is the best thing to use for this connection.

(It took the author about a week and several phone calls to determine that scope-probe cable isn't "plain old coax.")

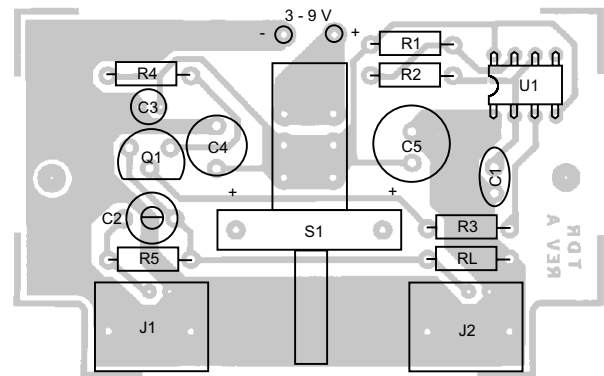




**Fig 36—Schematic diagram of the time-domain reflectometer. All resistors are 1/4-W, 5% tolerance. U1 is a CMOS 555 timer. Circuit current drain is 10 to 25 mA. When building the TDR, observe the construction cautions discussed in the text. C2 is available from Mouser Electronics, part no. ME242-8050. Right-angle BNC connectors for use at J1 and J2 can be obtained from Newark Electronics, part no. 89N1578. S1 can be obtained from All Electronics, part no. NISW-1. An SPST toggle switch can also be used at S1.**



**Fig 37—Full-size PC-board etching pattern for the TDR. Black areas represent unetched copper foil.**



**Fig 38—Part-placement diagram for the TDR. Parts are mounted on the nonfoil side of the board; the shaded area represents an X-ray view of the copper pattern. Be sure to observe the polarity markings of C3, C4 and C5.**

Probe cable has special characteristics that prevent undesired ringing and other problems.)

Mount a binding post at J1 and connect a scope probe to the binding post when testing cables with the TDR. R5 and C2 form a compensation network—much like the networks in oscilloscope probes—to adjust for effects of the probe wire.

The TDR is designed to operate from dc between 3 and 9 V. Two C cells (in series—3 V) supply operating voltage in this version. The circuit draws only 10 to 25 mA,

so the cells should last a long time (about 200 hours of operation). U1 can function with supply voltages as low as 2.25 to 2.5.

If you want to use the TDR in transmission-line systems with characteristic impedances other than 50 Ω, change the value of R<sub>L</sub> to match the system impedance as closely as possible.

### Calibrating and Using the TDR

Just about any scope with a bandwidth of at least

10 MHz should work fine with the TDR, but for tests in short-length cables, a 50-MHz scope provides for much more accurate measurements. To calibrate the TDR, terminate CABLE UNDER TEST connector, J2, with a 51-Ω resistor. Connect the scope vertical input to J1. Turn on the TDR, and adjust the scope timebase so that one square-wave cycle from the TDR fills as much of the scope display as possible (without uncalibrating the timebase). The waveform should resemble **Fig 39**. Adjust C2 to obtain maximum amplitude and sharpest corners on the observed waveform. That's all there is to the calibration process!

To use the TDR, connect the cable under test to J2, and connect the scope vertical input to J1. If the waveform you observe is different from the one you observed during calibration, there are impedance variations in the load you're testing. See **Fig 40**, showing an unterminated test cable connected to the TDR. The beginning of the cable is shown at point A. (AB represents the TDR output-pulse rise time.)

Segment AC shows the portion of the transmission line that has a 50-Ω impedance. Between points C and D, there is a mismatch in the line. Because the scope trace is higher than the 50-Ω trace, the impedance of this part of the line is higher than 50 Ω—in this case, an open circuit.

To determine the length of this cable, read the length of time over which the 50-Ω trace is displayed. The scope is set for 0.01 μs per division, so the time delay for the 50-Ω section is (0.01 μs × 4.6 divisions) = 0.046 μs. The manufacturer's specified velocity factor (VF) of the cable is 0.8. **Eq 1** tells us that the 50-Ω section of the cable is

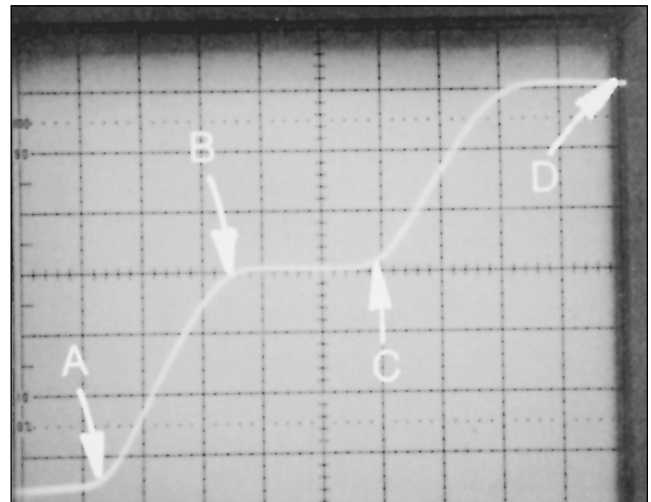
$$\ell = \frac{983.6 \times 0.8 \times 0.046 \mu\text{s}}{2} = 18.1 \text{ feet}$$

The TDR provides reasonable agreement with the actual cable length—in this case, the cable is really 16.5 feet long.

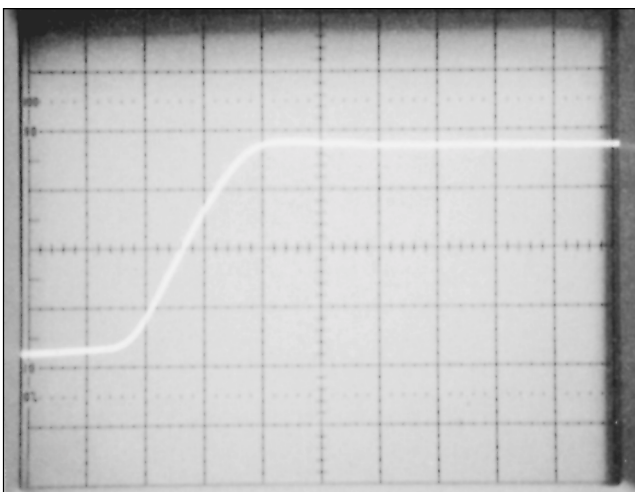
(Variations in TDR-derived calculations and actual cable lengths can occur as a result of cable VFs that can vary considerably from published values. Many cables vary as much as 10% from the specified values.)

A second example is shown in **Fig 41**, where a length of 3/4-inch Hardline is being tested. The line feeds a 432-MHz vertical antenna at the top of a tower. **Fig 41** shows that the 50-Ω line section has a delay of (6.6 divisions × 0.05 μs) = 0.33 μs. Because the trace is straight and level at the 50-Ω level, the line is in good shape. The trailing edge at the right-hand end shows where the antenna is connected to the feed line.

To determine the actual length of the line, use the same procedure as before: Using the published VF for the Hardline



**Fig 40—Open-circuited test cable.** The scope is set for 0.01 μs per division. See text for interpretation of the waveform.



**Fig 39—TDR calibration trace as shown on an oscilloscope.** Adjust C2 (See **Figs 36** and **38**) for maximum deflection and sharpest waveform corners during calibration. See text.



**Fig 41—TDR display of the impedance characteristics of the 142-foot Hardline run to the 432-MHz antenna at KD5HM.** The scope is set for 0.05 μs per division. See text for discussion.

(0.88) in Eq 1, the line length is

$$\ell = \frac{983.6 \times 0.88 \times 0.33 \mu\text{s}}{2} = 142.8 \text{ feet}$$

Again, the TDR-derived measurement is in close agreement with the actual cable length (142 feet).

### Final Notes

The time-domain reflectometer described here is not frequency specific; its measurements are not made at the frequency at which a system is designed to be used. Because of this, the TDR cannot be used to verify the impedance of an antenna, nor can it be used to measure cable loss at a specific frequency. Just the same, in two years of use, it has never failed to help locate a transmission-line problem. The vast majority of transmission-line problems result from improper cable installation or connector weathering.

### Limitations

Certain limitations are characteristic of TDRs because the signal used to test the line differs from the system operating frequency and because an oscilloscope is a broadband device. In the instrument described here, measurements are made with a 71-kHz square wave. That wave contains components at 71 kHz and odd harmonics thereof, with the majority of the energy coming from the lower frequencies. The leading edge of the trace indicates that the response drops quickly above 6 MHz. (The leading

edge in Fig 40 is 0.042  $\mu\text{s}$ , corresponding to a period of 0.168  $\mu\text{s}$  and a frequency of 5.95 MHz.) The result is dc pulses of approximately 7  $\mu\text{s}$  duration. The scope display combines the circuit responses to all of those frequencies. Hence, it may be difficult to interpret any disturbance which is narrowband in nature (affecting only a small range of frequencies, and thus a small portion of the total power), or for which the travel time plus pattern duration exceeds 7  $\mu\text{s}$ . The 432-MHz vertical antenna in Fig 41 illustrates a display error resulting from narrow-band response.

The antenna shows as a major impedance disturbance because it is mismatched at the low frequencies that dominate the TDR display, yet it is matched at 432 MHz. For an event that exceeds the observation window, consider a 1- $\mu\text{F}$  capacitor across a 50- $\Omega$  line. You would see only part of the pattern shown in Fig 35C because the time constant ( $1 \times 10^{-6} \times 50 = 50 \mu\text{s}$ ) is much larger than the 7- $\mu\text{s}$  window.

In addition, TDRs are unsuitable for measurements where there are major impedance changes inside the line section to be tested. Such major changes mask reflections from additional changes farther down the line.

Because of these limitations, TDRs are best suited for spotting faults in dc-continuous systems that maintain a constant impedance from the generator to the load. Happily, most amateur stations would be ideal subjects for TDR analysis, which can conveniently check antenna cables and connectors for short and open-circuit conditions and locate the position of such faults with fair accuracy.

## Ground Parameters for Antenna Analysis

This section is taken from an article in *The ARRL Antenna Compendium, Vol 5* by R. P. Haviland, W4MB. In the past, amateurs paid very little attention to the characteristics of the earth (ground) associated with their antennas. There are two reasons for this. First, these characteristics are not easy to measure—even with the best equipment, extreme care is needed. Second, almost all hams have to put up with what they have—there are very few who can afford to move because their location has poor ground conditions! Further, the ground is not a dominant factor in the most popular antennas—a tri-band Yagi at 40 feet or higher, or a 2-meter vertical at roof height, for example.

Even so, there has been a desire and even a need for ground data and for ways to use it. It is very important for vertically polarized antennas. Ground data is useful for antennas mounted at low heights generally, and for such specialized ones as Beverages. The performance of such antennas change a lot as the ground changes.

### Importance of Ground Conditions

To see why ground conditions can be important, let us look at some values. For a frequency of 10 MHz, *CCIR Recommendation 368*, gives the distance at which the signal

is calculated to drop 10 dB below its free-space level as:

Conductivity (mS/meter)	Distance for 10 dB Drop (km)
5000	100
30	15
3	0.3

The high-conductivity condition is for sea-water. Inter-island work in the Caribbean on 40 and 80 meters is easy, whereas 40-meter ground-wave contact is difficult for much of the USA, because of much lower ground conductivity. On the other hand, the Beverage works because of poor ground conductivity.

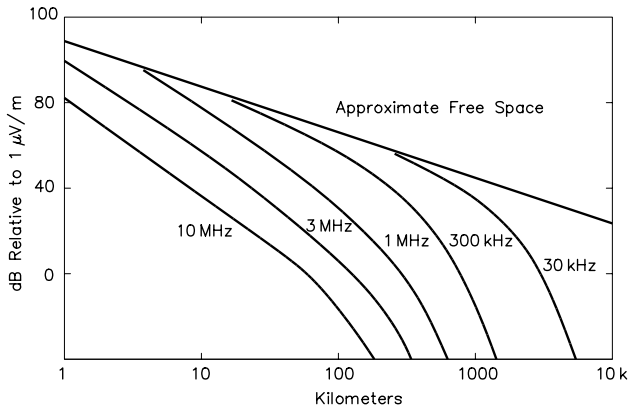
Fig 42 shows a typical set of expected propagation curves for a range of frequencies. This data is also from *CCIR Recommendation 368* for relatively poor ground, with a dielectric constant of 4 and a conductivity of 3 mS/m (one milliSiemens/meter is 0.001 mho/meter). The same data is available in the *Radio Propagation Handbook*. There are equivalent FCC curves, found in the book *Reference Data for Radio Engineers*, but only the ones near 160 meters are useful. In Florida the author has difficulty hearing stations across town on ground wave, an indication of the poor soil conditions—reflected sky-wave signals are often stronger.

## Securing Ground Data

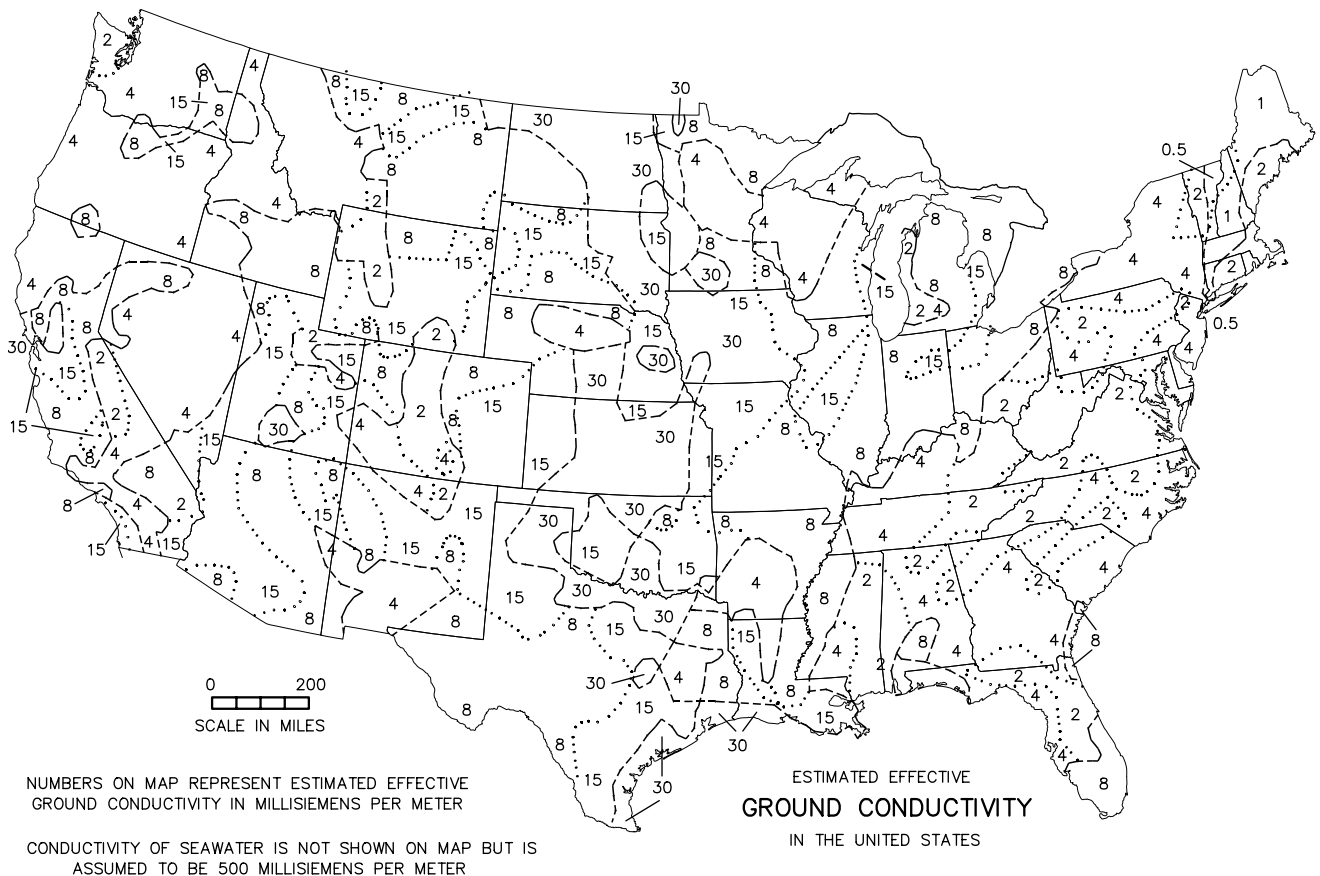
There are only two basic ways to approach this matter of ground data. One is to use generic ground data typical to the area. The second is to make measurements, which haven't really gotten easier. For most amateurs, the best approach seems to be a combination of these—use some simple measurements, and then use the generic data to make a better estimate. Because of equipment costs and measurement difficulties, none of these will be highly accurate for most hams. But they will be much better than simply taking some condition preset into an analysis program. Having a good set of values to plug into an analysis can help you evaluate the true worth of a new antenna project.

### Generic Data

In connection with its licensing procedure for broadcast stations, the FCC has published generic data for the entire country. This is reproduced in **Fig 43**, a chart showing the “estimated effective ground conductivity in the United States.” A range of 30:1 is shown, from 1 to 30 mS/m. An equivalent chart for Canada has been prepared, originally



**Fig 42—Variation of field strength with distance. Typical field strengths for several frequencies are shown. This is from CCIR data for fairly poor soil, with dielectric constant of 4 and conductivity of 3 mS/m. The curves for good soil are closer to the free-space line, and those for sea water are much closer to the free-space line.**



**Fig 43—Estimated effective ground conductivity in the United States. FCC map prepared for the Broadcast Service, showing typical conductivity for continental USA. Values are for the band 500 to 1500 KHz. Values are for flat, open spaces and often will not hold for other types of commonly found terrain, such as seashores, river beds, etc.**

by DOT, now DOC.

Of course, some judgment is needed when trying to use this data for your location. Broadcast stations are likely to be in open areas, so the data should not be assumed to apply to the center city. And a low site near the sea is likely to have better conductivity than the generic chart for, say, the coast of Oregon. Other than such factors, this chart gives a good first value, and a useful cross-check if some other method is used.

Still another FCC-induced data source is the license application of your local broadcast station. This includes calculated and measured coverage data. This may include specific ground data, or comparison of the coverage curves with the CCIR or FCC data to give the estimated ground conductivity. Another set of curves for ground conditions are those prepared by SRI. These give the conductivity and dielectric constant versus frequency for typical terrain conditions. These are reproduced as **Fig 44** and **Fig 45**. By inspecting your own site, you may select the curve most appropriate to your terrain. The curves are based on measurements at a number of sites across the USA, and are averages of the measured values.

Figs 46, 47 and 48 are data derived from these measurements. **Fig 46** gives the ground-dissipation factor. Sea water has low loss (a high dissipation factor), while soil

in the desert or in the city is very lossy, with a low dissipation factor. **Fig 47** gives the skin depth, the distance for the signal to decrease to 63% of its value at the surface. Penetration is low in high-conductivity areas and deep in low-conductivity soil. Finally, **Fig 48** shows the wavelength in the earth. For example, at 10 meters (30 MHz), the wavelength in sea water is less than 0.3 meters. Even in the desert, the wavelength has been reduced to about 6 meters at this frequency. This is one reason why buried antennas have peculiar properties. Lacking other data, it is suggested that the values of Figs 44 and 45 be used in computer antenna modeling programs.

### Measuring Ground Conditions

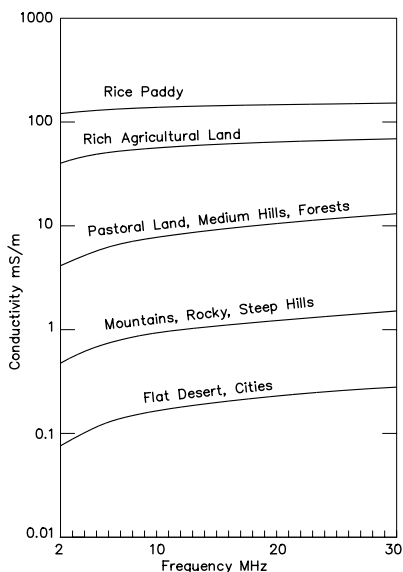
W2FNQ developed a simple technique to measure low-frequency earth conductivity, which has been used by W2FMI. The test setup is drawn in **Fig 49**, and uses a very old technique of 4-terminal resistivity measurements. For probes of  $\frac{1}{16}$ -inch diameter, spaced 18 inches and penetrating 12 inches into the earth, the conductivity is:

$$C = 21 V_1/V_2 \text{ mS/m} \quad (\text{Eq 19})$$

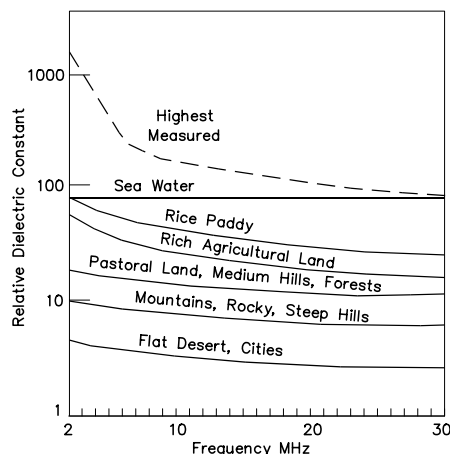
The voltages are conveniently measured by a digital voltmeter, to an accuracy of about 2%. In soil suitable for farming, the probes can be copper or aluminum. The strength of iron or copperweld may be needed in hard soils. A piece of  $2 \times 4$  or  $4 \times 4$  with guide holes drilled through it will help maintain proper spacing and vertical alignment of the probes. Use care when measuring—there is a shock hazard. An isolating transformer with a 24-V secondary instead of 115 V will reduce the danger.

Ground conditions vary quite widely over even small areas. It is best to make a number of measurements around the area of the antenna, and average the measured values.

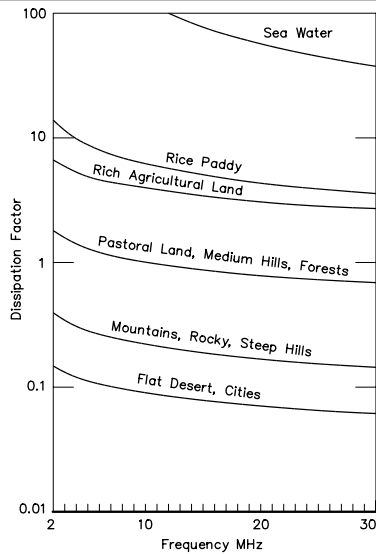
While this measurement gives only the low-frequency conductivity, it can be used to select curves in Fig 44 to give



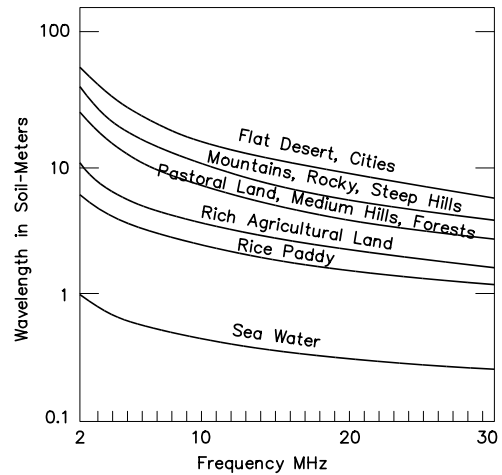
**Fig 44—Typical terrain conductivities versus frequency for 5 types of soils. This was measured by SRI. Units are mS/m. Conductivity of seawater is usually taken as 5000 mS/m. Conductivity of fresh water depends on the impurities present, and may be very low. To extrapolate conductivity values (for 500 to 1500 KHz) shown in Fig 43 for a particular geographic area to a different frequency, move from the conductivity at the left edge of Fig 44 to the desired frequency. For example, in rocky New Hampshire, with a conductivity of 1 mS/m at BC frequencies, the effective conductivity at 14 MHz would be approximately 4 mS/m.**



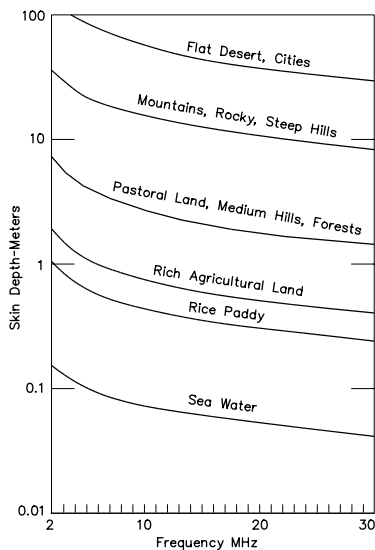
**Fig 45—Typical terrain relative dielectric constant for the 5 soil types of Fig 44, plus sea water. The dashed curve shows the highest measured values reported, and usually indicates mineralization.**



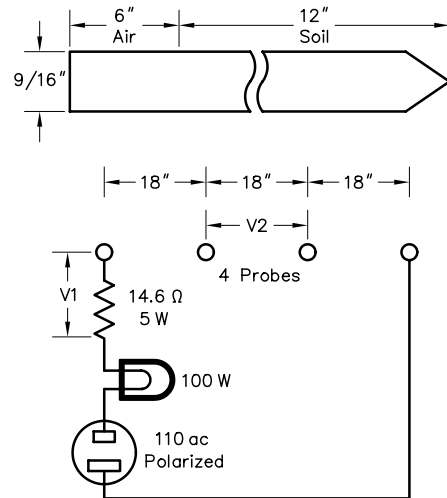
**Fig 46**—Typical values of dissipation factor. The soil behaves as a leaky dielectric. These curves showing the dimensionless dissipation factor versus frequency for various types of soils and for sea water. The dissipation factor is inversely related to soil conductivity. Among other things, a high dissipation factor indicates that a signal penetrating the soil or water will decrease in strength rapidly with depth.



**Fig 48**—Typical values of wavelength in soil. Because of its dielectric constant, the wavelength in soils and water will be shorter than that for a wave traveling in air. This can be important, since in a Method of Moment the accuracy is affected by the number of analysis segments per wavelength. Depending on the program being used, adjust the number of segments for antennas wholly or partly in the earth, for ground rods, and for antennas very close to earth.



**Fig 47**—Typical values of skin depth. The skin depth is the depth at which a signal will have decreased to 1/e of its value at the surface (to about 30%). The effective height above ground is essentially the same as the physical height for sea water, but may be much greater for the desert. For practical antennas, this may increase low-angle radiation, but at the same time will increase ground losses.



**Fig 49**—Low-frequency conductivity measurement system. A 60-Hz measuring system devised by W2FNQ and used by W2FMI. The basic system is widely used in geophysics. Use care to be certain that the plug connection is correct. A better system would use a lower voltage and an isolation transformer. Measure the value of  $V_2$  with no power applied—there may be stray ground currents present, especially if there is a power station or an electric railway close.

an estimate of the conductivity for the common ham bands. Assume that the 60 Hz value is valid at 2 MHz, and find the correct value on the left axis. Move parallel to the curves on the figure to develop the estimated curve for other soil conditions.

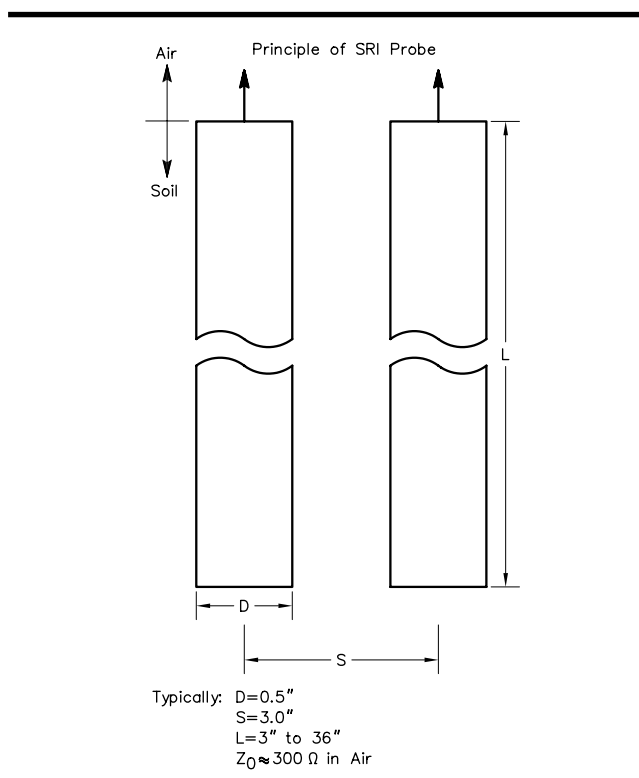
A small additional refinement is possible. If the dielectric constant from Fig 45 is plotted against the conductivity from Fig 44 for a given frequency, a scatter plot develops, showing a trend to higher dielectric constant as conductivity increases. At 14 MHz, the relation is:

$$k = \sqrt{1000/C} \quad (\text{Eq 20})$$

where k is the dielectric constant and C is the measured conductivity. Using these values in *MININEC* or *NEC* calculations should give better estimates than countrywide average values.

### Direct Measurement of Ground Properties

For really good values, both the conductivity and dielectric constant should be measured at the operating frequency. One way of doing this is the two-probe technique described in George Hagn's article (see Bibliography). This was the technique used to secure the data for Figs 44, 45,



**Fig 50—High-frequency conductivity/dielectric constant measurement system. System for measuring ground conditions at frequencies up to about 100 MHz, devised by SRI and used to obtain the data in Figs 44, 45, 46, 47 and 48. Basically, this is a section of transmission line with soil as the dielectric. Requires measurement of high impedances to good accuracy.**

46, 47 and 48. The principle is sketched in Fig 50. In essence, the two probes form a short, open-circuited, two-wire transmission line. As shown by the equations for such lines, the input impedance is a function of the conductivity and dielectric constant of the medium. A single measurement is difficult to calculate, since the end effect of the two probes must be determined, a complex task if they are pointed for easy driving. The calculation is greatly simplified if a set of measurements is made with several sets of probes that vary in length by a fixed ratio, since the measured difference is largely due to the increased two-wire length, with some change due to the change in soil moisture with depth.

The impedance to be measured is high because of the short line length, so impedance bridges are not really suitable. An RF vector impedance meter, such as the HP-4193A, is probably the best instrument to use, with a RF susceptance bridge, such as the GR-821A, next best. With care, a Q-meter can be substituted. Because of the rarity of these instruments among amateurs, this method of measurement is not explored further here.

### Indirect Measurement

Since the terminal impedance and resonant frequency of an antenna change as the antenna approaches earth, measurement of an antenna at one or more heights permits an analysis of the ground characteristics. The technique is to calculate the antenna drive impedance for an assumed ground condition, and compare this with measured values. If not the same, another set of ground conditions is assumed, and the process is repeated. It is best to have a plan to guide the assumptions.

In connection with his studies of transmission lines, Walt Maxwell, W2DU, made such measurements on 20, 40 and 80 meters. Some of the data was included in his book *Reflections*. The following example is based on his 80-meter data. Data came from his Table 20-1, for a 66-foot, 2-inch dipole of #14 wire at 40 feet above ground. His table gives an antenna impedance of  $72.59 + j 1.38 \Omega$  at 7.15 MHz.

Table 7 shows calculated antenna impedances for ground conductivities of three different ground conductivities: 10, 1 and 0.1 mS/m, and for dielectric constants of 3, 15 and 80. The nearest value to the measured drive impedance is for a conductivity of 0.1 mS/m and a dielectric constant of 3. Figs 44 and 45 indicate that these are typical of flat desert and city land. The effect on antenna performance is shown in Fig 51. The maximum lobe gain for soil typical of a city is over 2 dB lower than that for the high-conductivity, high-dielectric constant value. Note that the maximum lobe occurs for a radiation angle that is directly overhead.

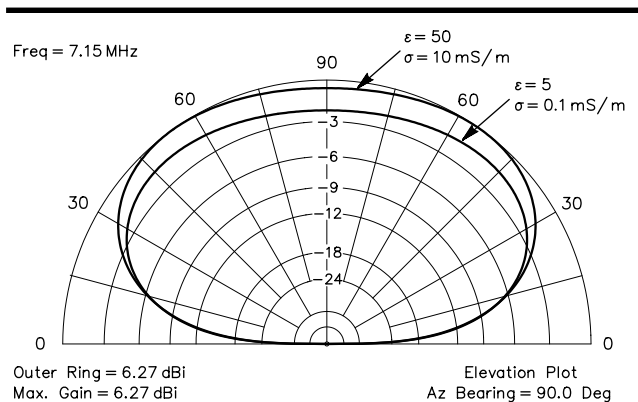
The ground at the W2DU QTH is a suburban Florida lot, covered with low, native vegetation. The ground is very sandy (a fossil sand dune), and is some 60-70 feet above sea-level. Measurements were made near the end of the Florida dry season. The water table is estimated to be 20 to 30 feet below the surface. Thus the calculated and measured values are reasonably consistent.

**Table 7**

**Calculated values of drive resistance, in ohms, for an 40 meter dipole at 40 feet elevation versus conductivity and dielectric constant.**

Conductivity (mS/m)	3	Dielectric Constant 15	50
10	89.78 - j 12.12	88.53 - j10.69	88.38 - j7.59
1	80.05 - j 17.54	83.72 - j 10.23	87.33 - j 6.98
0.1	76.44 - j 15.69	83.18 - j 9.85	97.30 - j 6.46

The value measured by W2DU was 72.59 - j 1.28 Ω, and compares closest to the poor soil condition of dielectric constant of 3 and conductivity of 0.1 mS/m.



**Fig 51—Plot showing computed elevation patterns for 40-foot high, 40-meter dipole for two different ground conditions: poor ground, with dielectric constant of 3 and conductivity of 0.1 mS/m, and good ground, with dielectric constant of 50 and conductivity of 10 mS/m. Note that for a low horizontal antenna, high-angle radiation is most affected by poor ground, with low-angle radiation least affected by ground characteristics.**

In principle, a further analysis, using values around 0.1 mS/m conductivity and 3 for dielectric constant, will give a better ground parameter estimate. However, the results should be taken with a grain of salt, because the opportunities for error in the computer modeling must be considered. The antenna should have no sag, and its length and height should be accurate. The measurement must be with accurate

equipment, free from strays, such as current on the outer conductor of the coax. The feed-point gap effect must be estimated. Further, the ground itself under the antenna must be flat and have constant characteristics for modeling to be completely accurate.

Finally, the feed-line length and velocity constant of the transmission line must be accurately measured for transfer of the measured values at the feeding end of the transmission line to the antenna itself. Because of all the possibilities for error, most attempts at precision should be based on measured values at two or three frequencies, and preferably at two or three heights. Orienting the antenna to right angles for another set of measurements may be useful. Obviously, this can involve a lot of detailed work.

The author was not been able to find any guidelines for the best height or frequency. The data in the book *Exact Image Method for Impedance Computation of Antennas Above the Ground* suggests that a height of  $0.3 \lambda$  will give good sensitivity to ground conditions. Very low heights may give confusing results, since several combinations of ground parameters can give nearly the same drive impedance. Both this data and experience suggest that sensitivity to ground for heights above  $0.75 \lambda$  is small or negligible.

If an overall conclusion about ground characteristics is needed, we can just restate from the first paragraph—it is not greatly important for the most common horizontally polarized antenna installations. But it's worth taking a look when you need to depart from typical situations, or when the performance of a vertically polarized antenna is contemplated. Then the techniques outlined here can be helpful.

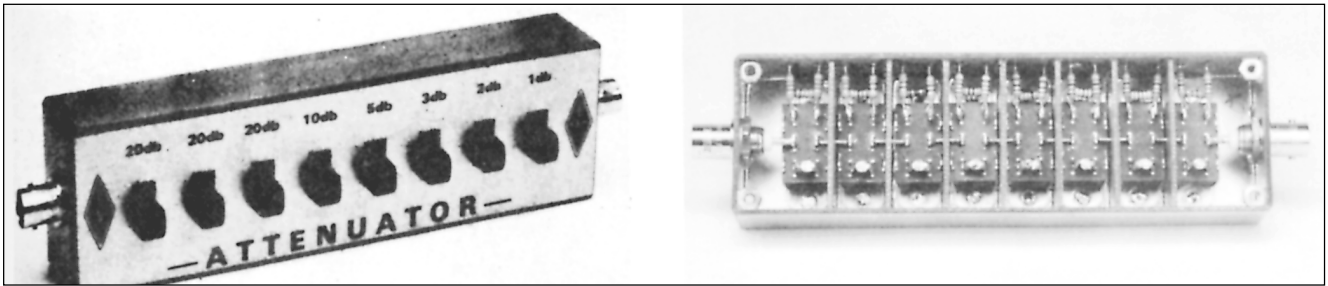
## A Switchable RF Attenuator

A switchable RF attenuator is helpful for making antenna-gain comparisons or for plotting antenna radiation patterns. You may switch attenuation in or out of the line leading to the receiver to obtain an initial reference reading on a signal strength meter. Some form of attenuator is also helpful for locating hidden transmitters, where the real trick is pinpointing the signal source from within a few hundred

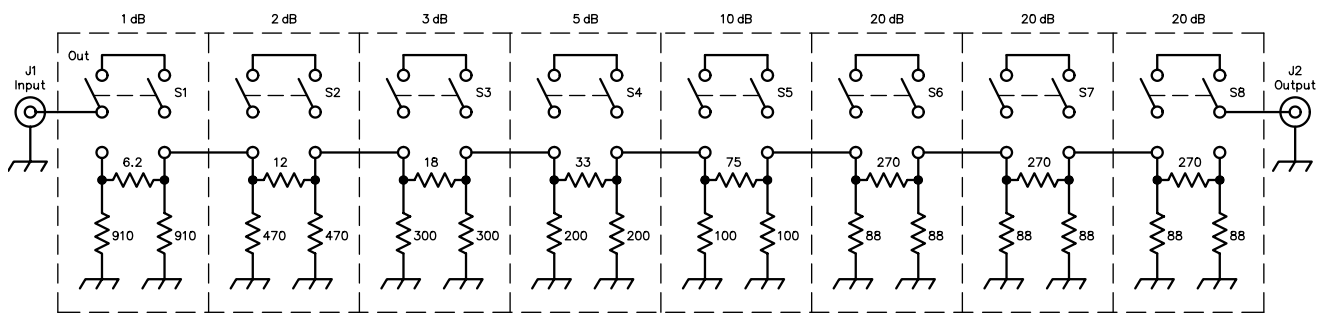
feet. At such a close distance, strong signals may overload the front end of the receiver, making it impossible to obtain any indication of a bearing.

The attenuator of **Figs 52** and **53** is designed for low power levels, not exceeding  $\frac{1}{4}$  watt. If for some reason the attenuator will be connected to a transceiver, a means of bypassing the unit during transmit periods must be devised.





**Fig 52—A construction method for a step attenuator. Double-sided circuit-board material, unetched (except for panel identification), is cut to the desired size and soldered in place. Flashing copper may also be used, although it is not as sturdy. Shielding partitions between sections are necessary to reduce signal leakage. Brass nuts soldered at each of the four corners allow machine screws to secure the bottom cover. The practical limit for total attenuation is 80 or 90 dB, as signal leakage around the outside of the attenuator will defeat attempts to obtain much greater amounts.**



**Fig 53—Schematic diagram of the step attenuator, designed for a nominal impedance of 50  $\Omega$ . Resistance values are in ohms. Resistors are  $\frac{1}{4}$ -watt, carbon-composition types, 5% tolerance. Broken lines indicate walls of circuit-board material. A small hole is drilled through each partition wall to route bus wire. Keep all leads as short as possible. The attenuator is bilateral; that is, the input and output ends may be reversed.**

**J1, J2—Female BNC connectors, Radio Shack 278-105 or equiv.**

**S1-S8, incl.—DPDT slide switches, standard size. (Avoid subminiature or toggle switches.) Stackpole S-5022CD03-0 switches are used here.**

An attenuator of this type is commonly called a *step attenuator*, because any amount of attenuation from 0 dB to the maximum available (81 dB for this particular instrument) may be obtained in steps of 1 dB. As each switch is successively thrown from the OUT to the IN position, the attenuation sections add in cascade to yield the total of the attenuator steps switched in. The maximum attenuation of any single section is limited to 20 dB because leak-through would probably degrade the accuracy of higher values. The tolerance of resistor values also becomes more significant regarding accuracy at higher attenuation values.

A good quality commercially made attenuator will cost upwards from \$150, but for less than \$25 in parts and a few hours of work, you can build an attenuator at home. It will be suitable for frequencies up to 450 MHz. Double-sided pc board is used for the enclosure. The version of the attenuator shown in Fig 52 has identification lettering etched into the top surface (or front panel) of the unit. This adds a nice touch and is a permanent means of labeling. Of course rub-on transfers or Dymo tape labels could be used as well.

Female BNC single-hole, chassis-mount connectors are used at each end of the enclosure. These connectors provide a means of easily connecting and disconnecting the attenuator.

### Construction

After all the box parts are cut to size and the necessary holes made, scribe light lines to locate the inner partitions. Carefully tack-solder all partitions in position. A 25-W pencil type of iron should provide sufficient heat. Dress any pc board parts that do not fit squarely. Once everything is in proper position, run a solder bead all the way around the joints. Caution! Do not use excessive amounts of solder, as the switches must later be fit flat inside the sections. Complete the top, sides, ends and partitions. Dress the outside of the box to suit your taste. For instance, you might wish to bevel the box edges. Buff the copper with steel wool, add lettering, and finish off the work with a coat of clear lacquer or polyurethane varnish.

Using a little lacquer thinner, soak the switches to

remove the grease that was added during their manufacture. When they dry, spray the inside of the switches lightly with a TV tuner cleaner/lubricant. Use a sharp drill bit (about  $\frac{3}{16}$  inch will do), and countersink the mounting holes on the actuator side of the switch mounting plate. This ensures that the switches will fit flush against the top plate. At one end of each switch, bend the two lugs over and solder them together. Cut off the upper halves of the remaining switch lugs. (A close look at Fig 52 will help clarify these steps.)

Solder the series-arm resistors between the appropriate switch lugs. Keep the lead lengths as short as possible and do not overheat the resistors. Now solder the switches in place to the top section of the enclosure by flowing solder through the mounting holes and onto the circuit-board material. Be certain that you place the switches in their proper positions; correlate the resistor values with the degree of attenuation. Otherwise, you may wind up with the 1-dB step at the wrong end of the box—how embarrassing!

Once the switches are installed, thread a piece of #18

bare copper wire through the center lugs of all the switches, passing it through the holes in the partitions. Solder the wire at each switch terminal. Cut the wire between the poles of each individual switch, leaving the wire connecting one switch pole to that of the neighboring one on the other side of the partition, as shown in Fig 52. At each of the two end switch terminals, leave a wire length of approximately  $\frac{1}{8}$  inch. Install the BNC connectors and solder the wire pieces to the connector center conductors.

Now install the shunt-arm resistors of each section. Use short lead lengths. Do not use excessive amounts of heat when soldering. Solder a no. 4-40 brass nut at each inside corner of the enclosure. Recess the nuts approximately  $\frac{1}{16}$ -inch from the bottom edge of the box to allow sufficient room for the bottom panel to fit flush. Secure the bottom panel with four no. 4-40,  $\frac{1}{4}$ -inch machine screws and the project is completed. Remember to use caution, always, when your test setup provides the possibility of transmitting power into the attenuator.

## A Portable Field Strength Meter

Few amateur stations, fixed or mobile, are without need of a field-strength meter. An instrument of this type serves many useful purposes during antenna experiments and adjustments. When work is to be done from many wavelengths away, a simple wavemeter lacks the necessary sensitivity. Further, such a device has a serious fault because its linearity leaves much to be desired. The information in this section is based on a January 1973 *QST* article by [Lew McCoy, WIICP](#).

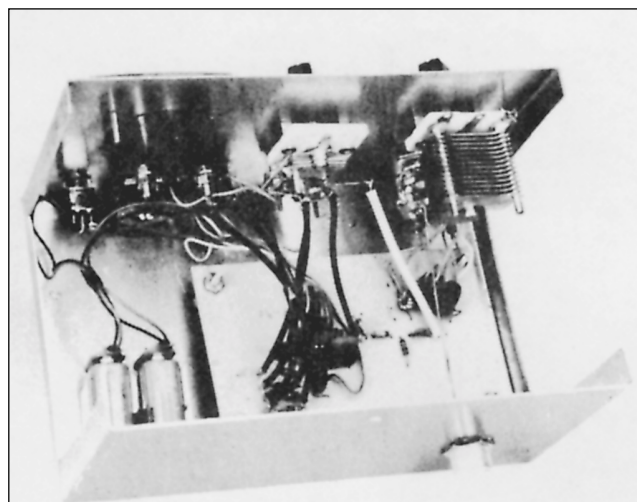
The field-strength meter described here takes care of these problems. Additionally, it is small, measuring only  $4 \times 5 \times 8$  inches. The power supply consists of two 9-volt

batteries. Sensitivity can be set for practically any amount desired. However, from a usefulness standpoint, the circuit should not be too sensitive or it will respond to unwanted signals. This unit also has excellent linearity with regard to field strength. (The field strength of a received signal varies inversely with the distance from the source, all other things being equal.) The frequency range includes all amateur bands from 3.5 through 148 MHz, with band-switched circuits, thus avoiding the use of plug-in inductors. All in all, it is a quite useful instrument.

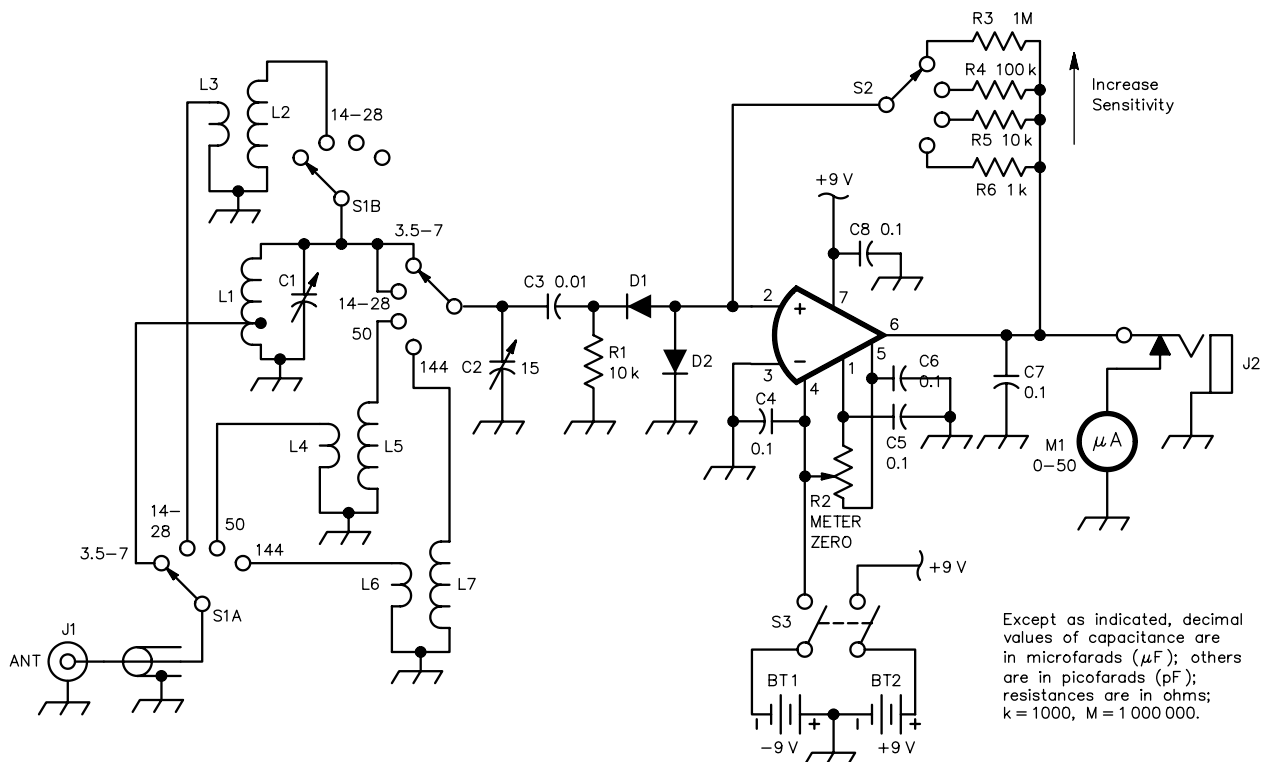
The unit is pictured in Figs 54 and 55, and the schematic diagram is shown in Fig 56. A type 741 op-amp IC is the



**Fig 54**—The linear field strength meter. The control at the upper left is for C1 and the one to the right for C2. At the lower left is the band switch, and to its right the sensitivity switch. The zero-set control for M1 is located directly below the meter.



**Fig 55**—Inside view of the field-strength meter. At the upper right is C1 and to the left, C2. The dark leads from the circuit board to the front panel are the shielded leads described in the text.



**Fig 56—Circuit diagram of the linear field strength meter. All resistors are 1/4- or 1/2-W composition types.**

**C1** — 140 pF variable.

**C2** — 15-pF variable

**D1, D2** — 1N914 or equiv.

**L1** — 34 turns #24 enam. wire wound on an Amidon

T-68-2 core, tapped 4 turns from ground end.

**L2** — 12 turns #24 enam. wire wound on T-68-2 core.

**L3** — 2 turns #24 enam. wire wound at ground end of L2.

**L4** — 1 turn #26 enam. wire wound at ground end of L5.

**L5** — 12 turns #26 enam. wire wound on T-25-12 core.

**L6** — 1 turn #26 enam. wire wound at ground end of L7.

**L7** — 1 turn #18 enam. wire wound on T-25-12 core.

**M1** — 50 or 100 μA dc.

**R2** — 10-kΩ control, linear taper.

**S1** — Rotary switch, 3 poles, 5 positions, 3 sections.

**S2** — Rotary switch, 1 pole, 4 positions.

**S3** — DPST toggle.

**U1** — Type 741 op amp. Pin numbers shown are for a 14-pin package.

heart of the unit. The antenna is connected to J1, and a tuned circuit is used ahead of a diode detector. The rectified signal is coupled as dc and amplified in the op amp. Sensitivity of the op amp is controlled by inserting resistors R3 through R6 in the circuit by means of S2.

With the circuit shown, and in its most sensitive setting, M1 will detect a signal from the antenna on the order of 100 μV. Linearity is poor for approximately the first 1/5 of the meter range, but then is almost straight-line from there to full-scale deflection. The reason for the poor linearity at the start of the readings is because of nonlinearity of the diodes at the point of first conduction. However, if gain measurements are being made this is of no real importance, as accurate gain measurements can be made in the linear portion of the readings.

The 741 op amp requires both a positive and a negative voltage source. This is obtained by connecting two 9-volt batteries in series and grounding the center. One other feature of the instrument is that it can be used remotely by connecting an external meter at J2. This is handy if you want

to adjust an antenna and observe the results without having to leave the antenna site.

L1 is the 3.5/7 MHz coil and is tuned by C1. The coil is wound on a toroid form. For 14, 21 or 28 MHz, L2 is switched in parallel with L1 to cover the three bands. L5 and C2 cover approximately 40 to 60 MHz, and L7 and C2 from 130 MHz to approximately 180 MHz. The two VHF coils are also wound on toroid forms.

### Construction Notes

The majority of the components may be mounted on an etched circuit board. A shielded lead should be used between pin 4 of the IC and S2. The same is true for the leads from R3 through R6 to the switch. Otherwise, parasitic oscillations may occur in the IC because of its very high gain.

In order for the unit to cover the 144-MHz band, L6 and L7 should be mounted directly across the appropriate terminals of S1, rather than on a circuit board. The extra lead length adds too much stray capacitance to the circuit. It isn't necessary to use toroid forms for the 50- and 144-MHz

coils. They were used in the version described here simply because they were available. You may substitute air-wound coils of the appropriate inductance.

### Calibration

The field strength meter can be used *as is* for a relative-reading device. A linear indicator scale will serve admirably. However, it will be a much more useful instrument for antenna work if it is calibrated in decibels, enabling the user to check relative gain and front-to-back ratios. If you have access to a calibrated signal generator, connect it to the field-strength meter and use different signal levels fed to the device to make a calibration chart. Convert signal-generator voltage ratios to decibels by using the equation

$$\text{dB} = 20 \log (V1/V2) \quad (\text{Eq 21})$$

where

V1/V2 is the ratio of the two voltages  
log is the common logarithm (base 10)

Let's assume that M1 is calibrated evenly from 0 to 10. Next, assume we set the signal generator to provide a reading of 1 on M1, and that the generator is feeding a 100- $\mu\text{V}$  signal into the instrument. Now we increase the generator output to 200  $\mu\text{V}$ , giving us a voltage ratio of 2:1. Also let's assume M1 reads 5 with the 200- $\mu\text{V}$  input. From the equation above, we find that the voltage ratio of 2 equals 6.02 dB between 1 and 5 on the meter scale. M1 can be calibrated more accurately between 1 and 5 on its scale by adjusting the generator and figuring the ratio. For example, a ratio of 126  $\mu\text{V}$  to 100  $\mu\text{V}$  is 1.26, corresponding to 2.0 dB.

By using this method, all of the settings of S2 can be calibrated. In the instrument shown here, the most sensitive setting of S2 with R3, 1 M $\Omega$ , provides a range of approximately 6 dB for M1. Keep in mind that the meter scale for each setting of S1 must be calibrated similarly for each band. The degree of coupling of the tuned circuits for the different bands will vary, so each band must be calibrated separately.

Another method for calibrating the instrument is using a transmitter and measuring its output power with an RF wattmeter. In this case we are dealing with power rather than voltage ratios, so this equation applies:

$$\text{dB} = 10 \log (P1/P2) \quad (\text{Eq 22})$$

where P1/P2 is the power ratio.

With most transmitters the power output can be varied, so calibration of the test instrument is rather easy. Attach a pickup antenna to the field-strength meter (a short wire a foot or so long will do) and position the device in the transmitter antenna field. Let's assume we set the transmitter output for 10 W and get a reading on M1. We note the reading and then increase the output to 20 W, a power ratio of 2. Note the reading on M1 and then use [Eq 2](#). A power ratio of 2 is 3.01 dB. By using this method the instrument can be calibrated on all bands and ranges.

With the tuned circuits and coupling links specified in [Fig 56](#), this instrument has an average range on the various bands of 6 dB for the two most sensitive positions of S2, and 15 dB and 30 dB for the next two successive ranges. The 30-dB scale is handy for making front-to-back antenna measurements without having to switch S2.

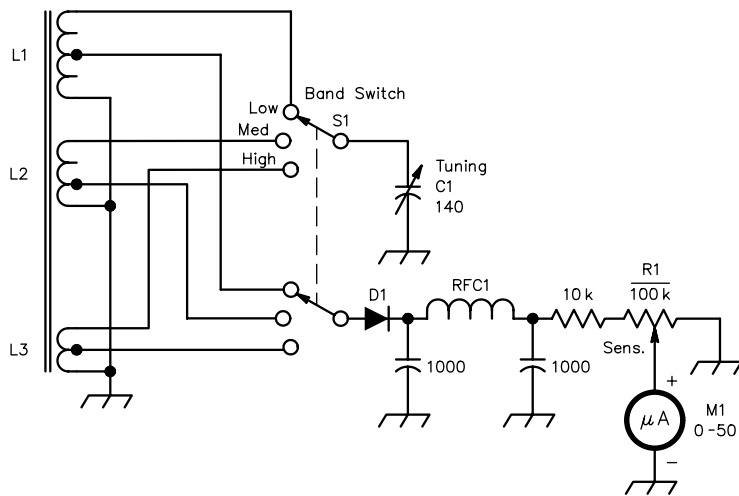
## An RF Current Probe

The RF current probe of [Figs 57, 58 and 59](#) operates on the magnetic component of the electromagnetic field, rather than the electric field. Since the two fields are precisely related, as discussed in [Chapter 23](#), the relative field strength measurements are completely equivalent. The use of the magnetic field offers certain advantages, however. The instrument may be made more compact for the same sensitivity, but its principal advantage is that it may be used near a conductor to measure the current flow without cutting the conductor.

In the average amateur location there may be substantial currents flowing in guy wires, masts and towers, coaxial-

**Fig 57—The RF current probe. The sensitivity control is mounted at the top of the instrument, with the tuning and band switches on the lower portion of the front panel. Frequency calibration of the tuning control was not considered necessary for the intended use of this particular instrument, but marks identifying the various amateur bands would be helpful. If the unit is provided with a calibrated dial, it can also be used as an absorption wavemeter.**



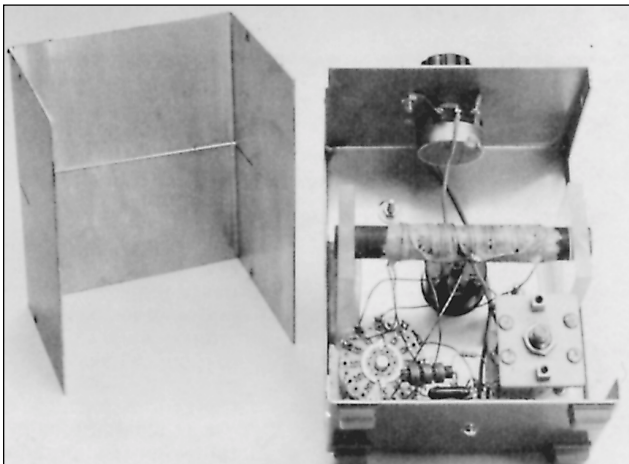


**Fig 58—Schematic diagram of the RF current probe. Resistances are in ohms;  $k = 1000$ . Capacitances are in picofarads; fixed capacitors are silver mica. Be sure to ground the rotor of C1, rather than the stator, to avoid hand capacitance. L1, L2 and L3 are each close-wound with #22 enameled wire on a single ferrite rod, 4 inch long and  $\frac{1}{2}$  inch diameter, with  $\mu = 125$  (Amidon R61-50-400). Windings are spaced approximately  $\frac{1}{4}$  inch apart. C1—Air variable, 6-140 pF; Hammarlund HF140 or equiv. D1—Germanium diode; 1N34A, 1N270 or equiv. L1—1.6-5 MHz; 30 turns, tapped at 3 turns from grounded end. L2—5-20 MHz; 8 turns, tapped at 2 turns from grounded end. L3—17-39 MHz; 2 turns, tapped at 1 turn. M1—Any microammeter may be used. The one pictured is a Micronta meter, RadioShack no. 270-1751. R1—Linear taper. RFC1—1 mH; Miller no. 4642 or equiv. Value is not critical. S1—Ceramic rotary switch, 1 section, 2 poles, 2 to 6 positions; Centralab PA2002 or PA2003 or equiv.**

cable braids, gutters and leaders, water and gas pipes, and perhaps even drainage pipes. Current may be flowing in telephone and power lines as well. All of these RF currents may have an influence on antenna patterns or can be of significance in the case of RFI.

The circuit diagram of the current probe appears in Fig 58, and construction is shown in the photo, Fig 59. The winding data given here apply only to a ferrite rod of the particular dimensions and material specified. Almost any microammeter can be used, but it is usually convenient to use a rather sensitive meter and provide a series resistor to swamp out nonlinearity arising from diode conduction characteristics. A control is also used to adjust instrument sensitivity as required during operation. The tuning capacitor may be almost anything that will cover the desired range.

As shown in the photos, the circuit is constructed in a metal box. This enclosure shields the detector circuit from the electric field of the radio wave. A slot must be cut with a hacksaw across the back of the box, and a thin file may be used to smooth the cut. This slot is necessary to prevent the box from acting as a shorted turn.



**Fig 59—The current probe just before final assembly. Note that all parts except the ferrite rod are mounted on a single half of the  $3 \times 4 \times 5$ -inch Minibox (Bud CU-2105B or equiv.). Rubber grommets are fitted in holes at the ends of the slot to accept the rod during assembly of the enclosure. Leads in the RF section should be kept as short as possible, although those from the rod windings must necessarily be left somewhat long to facilitate final assembly.**

### Using the Probe

In measuring the current in a conductor, the ferrite rod should be kept at right angles to the conductor, and at a constant distance from it. In its upright or vertical position, this instrument is oriented for taking measurements in vertical conductors. It must be laid horizontal to measure current in horizontal conductors.

Numerous uses for the instrument are suggested in an earlier paragraph. In addition, the probe is an ideal instrument for checking the current distribution in antenna elements. It is also useful for measuring RF ground currents in radial systems. A buried radial may be located easily by sweeping the ground. Current division at junctions may be investigated. *Hot spots* usually indicate areas where additional radials would be effective.

Stray currents in conductors not intended to be part of the antenna system may often be eliminated by bonding or by changing the physical lengths involved. Guy wires and other unwanted parasitic elements will often give a tilt to the plane of polarization and can make a marked difference in front-to-back ratios. When the ferrite rod is oriented parallel to the electric field lines, there will be a sharp null

reading that may be used to locate the plane of polarization quite accurately. When using the meter, remember that the magnetic field is at right angles to the electric field.

You may also use the current probe as a relative signal strength meter. When making measurements on a vertical

antenna, locate the meter at least two wavelengths away, with the rod in a horizontal position. For horizontal antennas, hold the instrument at approximately the same height as the antenna, with the rod vertical.

## Antenna Measurements

Of all the measurements made in Amateur Radio systems, perhaps the most difficult and least understood are various measurements of antennas. For example, it is relatively easy to measure the frequency and CW power output of a transmitter, the response of a filter, or the gain of an amplifier. These are all what might be called *bench measurements* because, when performed properly, all the factors that influence the accuracy and success of the measurement are under control. In making antenna measurements, however, the “bench” is probably your backyard. In other words, the environment surrounding the antenna can affect the results of the measurement.

Control of the environment is not at all as simple as it was for the bench measurement, because now the work area may be rather spacious. This section describes antenna measurement techniques that are closely allied to those used in an antenna measuring event or contest. With these procedures you can make measurements successfully and with meaningful results. These techniques should provide a better understanding of the measurement problems, resulting in a more accurate and less difficult task. The information in this section was provided by [Dick Turrin, W2IMU](#), and was originally published in November 1974 *QST*.

### SOME BASIC IDEAS

An antenna is simply a transducer or coupler between a suitable feed line and the environment surrounding it. In addition to the efficient transfer of power from feed line to environment, an antenna at VHF or UHF is most frequently required to concentrate the radiated power into a particular region of the environment.

To be consistent while comparing different antennas, you must standardize the environment surrounding the antenna. Ideally, you want to make measurements with the measured antenna so far removed from any objects causing environmental effects that it is literally in outer space—a very impractical situation. The purpose of the measurement techniques is therefore to simulate, under practical conditions, a *controlled environment*. At VHF and UHF, and with practical-size antennas, the environment can be controlled so that successful and accurate measurements can be made in a reasonable amount of space.

The electrical characteristics of an antenna that are most desirable to obtain by direct measurement are: (1) gain (relative to an isotropic source, which by definition has a

gain of unity); (2) space-radiation pattern; (3) feed-point impedance (mismatch) and (4) polarization.

### Polarization

In general the polarization can be assumed from the geometry of the radiating elements. That is to say, if the antenna consists of a number of linear elements (straight lengths of rod or wire that are resonant and connected to the feed point) the polarization of the electric field will be linear and polarized parallel to the elements. If the elements are not consistently parallel with each other, then the polarization cannot easily be assumed. The following techniques are directed to antennas having polarization that is essentially linear (in one plane), although the method can be extended to include all forms of elliptic (or mixed) polarization.

### Feed-Point Mismatch

The feed-point mismatch, although affected to some degree by the immediate environment of the antenna, does not affect the gain or radiation characteristics of an antenna. If the immediate environment of the antenna does not affect the feed-point impedance, then any mismatch intrinsic to the antenna tuning reflects a portion of the incident power back to the source. In a receiving antenna this reflected power is reradiated back into the environment, and can be lost entirely.

In a transmitting antenna, the reflected power travels back down the feed line to the transmitter, where it changes the load impedance presented to that transmitter. The amplifier output controls are customarily altered during the normal tuning procedure to obtain maximum power transfer to the antenna. You can still use a mismatched antenna to its full gain potential, provided the mismatch is not so severe as to cause heating losses in the system, especially the feed line and matching devices. (See also the discussion of additional loss caused by SWR in [Chapter 24](#).)

Similarly, a mismatched receiving antenna may be matched into the receiver front end for maximum power transfer. In any case you should clearly keep in mind that the feed-point mismatch does not affect the radiation characteristics of an antenna. It can only affect the system efficiency when heating losses are considered.

Why then do we include feed-point mismatch as part of the antenna characteristics? The reason is that for efficient system performance, most antennas are resonant transducers

and present a reasonable match over a relatively narrow frequency range. It is therefore desirable to design an antenna, whether it be a simple dipole or an array of Yagis, such that the final single feed-point impedance is essentially resistive and matched to the feed line. Furthermore, in order to make accurate, absolute gain measurements, it is vital that the antenna under test accept all the power from a matched-source generator, or that the reflected power caused by the mismatch be measured and a suitable error correction for heating losses be included in the gain calculations. Heating losses may be determined from information contained in [Chapter 24](#).

While on the subject of feed-point impedance, mention should be made of the use of *baluns* in antennas. A balun is simply a device that permits a lossless transition between a balanced system—feed line or antenna—and an unbalanced feed line or system. If the feed point of an antenna is symmetric, such as with a dipole, and it is desired to feed this antenna with an unbalanced feed line such as coax, you should provide a balun between the line and the feed point. Without the balun, current will be allowed to flow on the outside of the coax. The current on the outside of the feed line will cause radiation, and thus the feed line will become part of the antenna radiation system. In the case of beam antennas, where it is desired to concentrate the radiated energy in a specific direction, this extra radiation from the feed line will be detrimental, causing distortion of the expected antenna pattern. See [Chapter 26](#) for additional details on this problem.

### ANTENNA TEST SITE SET-UP AND EVALUATION

Since an antenna is a reciprocal device, measurements of gain and radiation patterns can be made with the test antenna used either as a transmitting or as a receiving antenna. In general and for practical reasons, the test antenna is used in the receiving mode, and the source or transmitting antenna is located at a specified fixed remote site and unattended. In other words the source antenna, energized by a suitable transmitter, is simply required to illuminate or flood the receiving site in a controlled and constant manner.

As mentioned earlier, antenna measurements ideally should be made under free-space conditions. A further restriction is that the illumination from the source antenna be a *plane wave* over the effective aperture (capture area) of the test antenna. A plane wave by definition is one in which the magnitude and phase of the fields are uniform, and in the test-antenna situation, *uniform over the effective area plane of the test antenna*. Since it is the nature of all radiation to expand in a spherical manner at great distance from the source, it would seem to be most desirable to locate the source antenna as far from the test site as possible. However, since for practical reasons the test site and source location will have to be near the earth and not in outer space, the environment must include the effects of the ground surface and other obstacles in the vicinity of both antennas.

These effects almost always dictate that the test range (spacing between source and test antennas) be as short as possible consistent with maintaining a nearly error-free plane wave illuminating the test *aperture*.

A nearly error-free plane wave can be specified as one in which the phase and amplitude, from center to edge of the illuminating field over the test aperture, do not deviate by more than about 30° and 1 decibel, respectively. These conditions will result in a gain-measurement error of no more than a few percent less than the true gain. Based on the 30° phase error alone, it can be shown that the minimum range distance is approximately

$$S_{\min} = 2 \frac{D^2}{\lambda} \quad (\text{Eq 23})$$

where  $D$  is the largest aperture dimension and  $\lambda$  is the free-space wavelength in the same units as  $D$ . The phase error over the aperture  $D$  for this condition is  $1/16$  wavelength.

Since aperture size and gain are related by

$$\text{Gain} = \frac{4\pi A_e}{\lambda^2} \quad (\text{Eq 24})$$

where  $A_e$  is the effective aperture area, the dimension  $D$  may be obtained for simple aperture configurations. For a square aperture

$$D_2 = G \frac{\lambda^2}{4\pi} \quad (\text{Eq 25})$$

that results in a minimum range distance for a square aperture of

$$S_{\min} = G \frac{\lambda}{2\pi} \quad (\text{Eq 26})$$

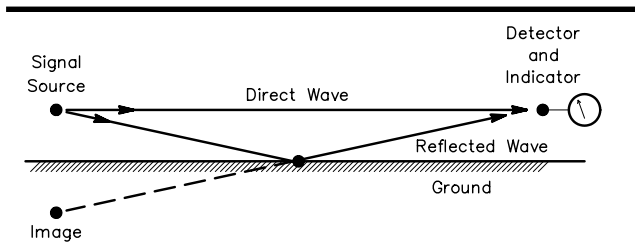
and for a circular aperture of

$$S_{\min} = G \frac{2\lambda}{\pi^2} \quad (\text{Eq 27})$$

For apertures with a physical area that is not well defined or is much larger in one dimension than in other directions, such as a long thin array for maximum directivity in one plane, it is advisable to use the maximum estimate of  $D$  from either the expected gain or physical aperture dimensions.

Up to this point in the range development, only the conditions for minimum range length,  $S_{\min}$ , have been established, as though the ground surface were not present. This minimum  $S$  is therefore a necessary condition even under free-space environment. The presence of the ground further complicates the range selection, not in the determination of  $S$  but in the exact location of the source and test antennas above the earth.

It is always advisable to select a range whose intervening terrain is essentially flat, clear of obstructions, and of uniform surface conditions, such as all grass or all pavement. The extent of the range is determined by the



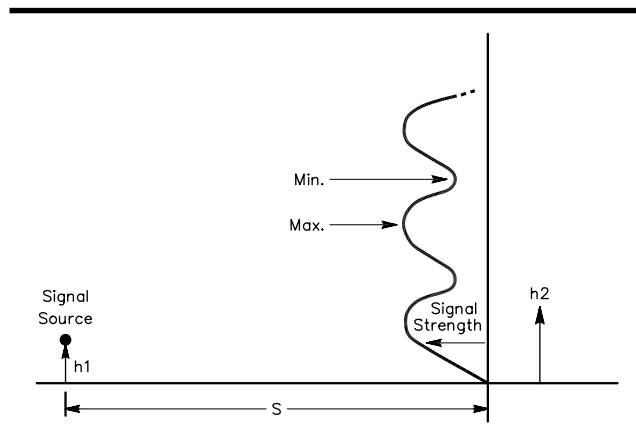
**Fig 60**—On an antenna test range, energy reaching the receiving equipment may arrive after being reflected from the surface of the ground, as well as by the direct path. The two waves may tend to cancel each other, or may reinforce one another, depending on their phase relationship at the receiving point.

illumination of the source antenna, usually a Yagi, whose gain is no greater than the highest gain antenna to be measured. For gain measurements the range consists essentially of the region in the beam of the test antenna. For radiation-pattern measurements, the range is considerably larger and consists of all that area illuminated by the source antenna, especially around and behind the test site. Ideally you should choose a site where the test-antenna location is near the center of a large open area and the source antenna is located near the edge where most of the obstacles (trees, poles, fences, etc.) lie.

The primary effect of the range surface is that some of the energy from the source antenna will be reflected into the test antenna, while other energy will arrive on a direct line-of-sight path. This is illustrated in **Fig 60**. The use of a flat, uniform ground surface assures that there will be essentially a mirror reflection, even though the reflected energy may be slightly weakened (absorbed) by the surface material (ground). In order to perform an analysis you should realize that horizontally polarized waves undergo a 180° phase reversal upon reflection from the earth. The resulting illumination amplitude at any point in the test aperture is the vector sum of the electric fields arriving from the two directions, the direct path and the reflected path.

If a perfect mirror reflection is assumed from the ground (it is nearly that for practical ground conditions at VHF/UHF) and the source antenna is isotropic, radiating equally in all directions, then a simple geometric analysis of the two path lengths will show that at various point in the vertical plane at the test-antenna site the waves will combine in different phase relationships. At some points the arriving waves will be in phase, and at other points they will be 180° out of phase. Since the field amplitudes are nearly equal, the resulting phase change caused by path length difference will produce an amplitude variation in the vertical test site direction similar to a standing wave, as shown in **Fig 61**.

The simplified formula relating the location of h2 for maximum and minimum values of the two-path summation in terms of h1 and S is



**Fig 61**—The vertical profile, or plot of signal strength versus test-antenna height, for a fixed height of the signal source above ground and at a fixed distance. See text for definitions of symbols.

$$h2 = n \frac{\lambda}{4} \times \frac{S}{h1} \quad (\text{Eq 28})$$

with  $n = 0, 2, 4, \dots$  for minimums and  $n = 1, 3, 5, \dots$  for maximums, and S is much larger than either h1 or h2.

The significance of this simple ground reflection formula is that it permits you to determine the approximate location of the source antenna to achieve a nearly plane-wave amplitude distribution *in the vertical direction* over a particular test *aperture size*. It should be clear from examination of the height formula that as h1 is decreased, the vertical distribution pattern of signal at the test site, h2, expands. Also note that the signal level for h2 equal to zero is always zero on the ground regardless of the height of h1.

The objective in using the height formula then is, given an effective antenna aperture to be illuminated from which a minimum S (range length) is determined and a suitable range site chosen, to find a value for h1 (source antenna height). The required value is such that the *first* maximum of vertical distribution at the test site, h2, is at a practical distance above the ground, and at the same time the signal amplitude over the aperture in the vertical direction does not vary more than about 1 dB. This last condition is not sacred but is closely related to the particular antenna under test.

In practice these formulas are useful only to initialize the range setup. A final check of the vertical distribution at the test site must be made by direct measurement. This measurement should be conducted with a small low-gain but unidirectional probe antenna such as a corner reflector or 2-element Yagi that you move along a vertical line over the intended aperture site. Care should be exercised to minimize the effects of local environment around the probe antenna and that the beam of the probe be directed at the source antenna at all times for maximum signal. A simple dipole is undesirable as a probe antenna because it is susceptible to local environmental effects.



The most practical way to instrument the vertical distribution measurement is to construct some kind of vertical track, preferably of wood, with a sliding carriage or platform that may be used to support and move the probe antenna. It is assumed of course that a stable source transmitter and calibrated receiver or detector are available so variations of the order of  $1/2$  dB can be clearly distinguished.

Once you conduct these initial range measurements successfully, the range is now ready to accommodate any aperture size less in vertical extent than the largest for which  $S_{\min}$  and the vertical field distribution were selected. Place the test antenna with the center of its aperture at the height  $h_2$  where maximum signal was found. Tilt the test antenna tilted so that its main beam is pointed in the direction of the source antenna. The final tilt is found by observing the receiver output for maximum signal. This last process must be done empirically since the apparent location of the source is somewhere between the actual source and its image, below the ground.

An example will illustrate the procedure. Assume that we wish to measure a 7-foot diameter parabolic reflector antenna at 1296 MHz ( $\lambda = 0.75$  foot). The minimum range distance,  $S_{\min}$ , can be readily computed from the formula for a circular aperture.

$$S_{\min} = 2 \frac{D^2}{\lambda} = 2 \times \frac{49}{0.75} = 131 \text{ feet}$$

Now a suitable site is selected based on the qualitative discussion given before.

Next determine the source height,  $h_1$ . The procedure is to choose a height  $h_1$  such that the first minimum above ground ( $n = 2$  in formula) is at least two or three times the aperture size, or about 20 feet.

$$h_1 = n \frac{\lambda}{4} \frac{S}{h_1} = 2 \times \frac{0.75}{4} \times \frac{131}{20} = 2.5 \text{ feet}$$

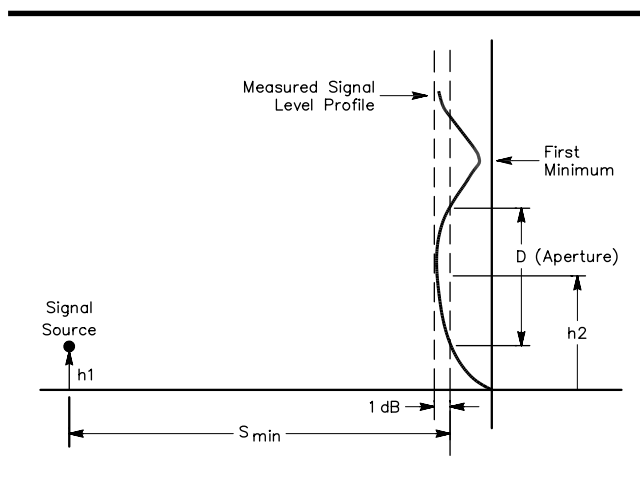


Fig 62—Sample plot of a measured vertical profile.

Place the source antenna at this height and probe the vertical distribution over the 7-foot aperture location, which will be about 10 feet off the ground.

$$h_2 = n \frac{\lambda}{4} \frac{S}{h_1} = 1 \times \frac{0.75}{4} \times \frac{131}{2.5} = 9.8 \text{ feet}$$

Plot the measured profile of vertical signal level versus height. From this plot, empirically determine whether the 7-foot aperture can be fitted in this profile such that the 1-dB variation is not exceeded. If the variation exceeds 1 dB over the 7-foot aperture, the source antenna should be lowered and  $h_2$  raised. Small changes in  $h_1$  can quickly alter the distribution at the test site. Fig 62 illustrates the points of the previous discussion.

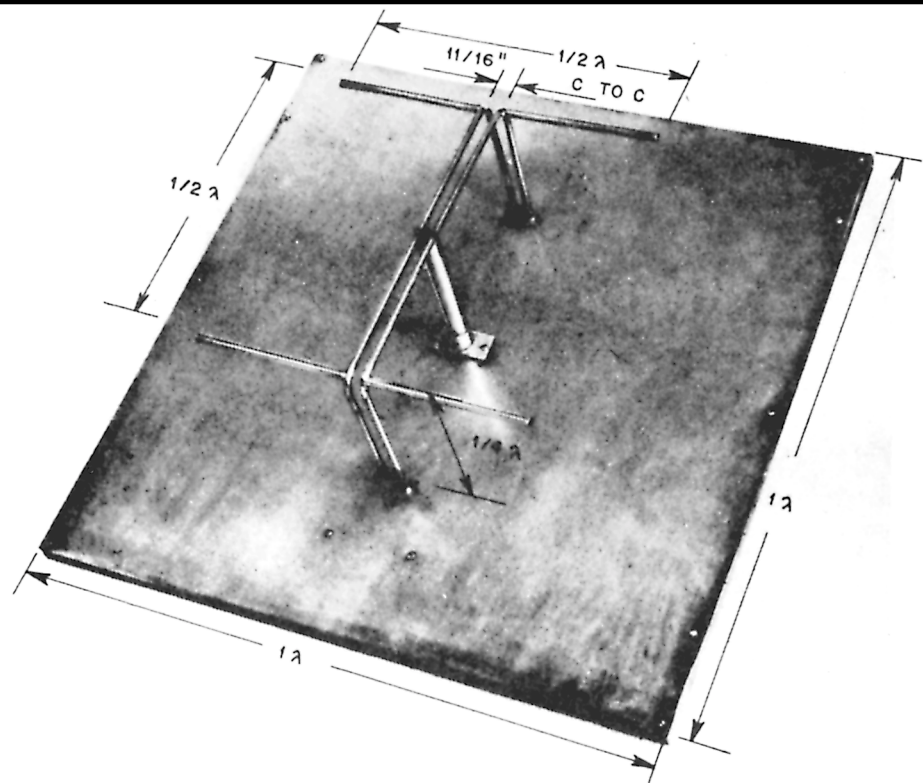
The same set-up procedure applies for either horizontal or vertical linear polarization. However, it is advisable to check by direct measurement at the site for each polarization to be sure that the vertical distribution is satisfactory. Distribution probing in the horizontal plane is unnecessary as little or no variation in amplitude should be found, since the reflection geometry is constant. Because of this, antennas with apertures that are long and thin, such as a stacked collinear vertical, should be measured with the long dimension parallel to the ground.

A particularly difficult range problem occurs in measurements of antennas that have depth as well as cross-sectional aperture area. Long end-fire antennas such as long Yagis, rhombics, V-beams, or arrays of these antennas, radiate as *volumetric arrays* and it is therefore even more essential that the illuminating field from the source antenna be reasonably uniform in depth as well as plane wave in cross section. For measuring these types of antennas it is advisable to make several vertical profile measurements that cover the depth of the array. A qualitative check on the integrity of the illumination for long end-fire antennas can be made by moving the array or antenna axially (forward and backward) and noting the change in received signal level. If the signal level varies less than 1 or 2 dB for an axial movement of several wavelengths then the field can be considered satisfactory for most demands on accuracy. Large variations indicate that the illuminating field is badly distorted over the array depth and subsequent measurements are questionable. It is interesting to note in connection with gain measurements that any illuminating field distortion will always result in measurements that are lower than true values.

### ABSOLUTE GAIN MEASUREMENT

Having established a suitable range, the measurement of gain relative to an isotropic (point source) radiator is almost always accomplished by direct comparison with a calibrated standard-gain antenna. That is, the signal level with the test antenna in its optimum location is noted. Then you remove the test antenna and place the standard-gain antenna with its aperture at the center of location where the test antenna was located. Measure the difference in signal level between the standard and the test antennas and add to

**Fig 63—Standard-gain antenna. When accurately constructed for the desired frequency, this antenna will exhibit a gain of 7.7 dB over a dipole radiator, plus or minus 0.25 dB. In this model, constructed for 432 MHz, the elements are  $\frac{3}{8}$ -inch diameter tubing. The phasing and support lines are of  $\frac{5}{16}$ -inch diameter tubing or rod.**



or subtract from the gain of the standard-gain antenna to obtain the absolute gain of the test antenna. Here, *absolute* means with respect to a point source with a gain of unity, by definition. The reason for using this reference rather than a dipole, for instance, is that it is more useful and convenient for system engineering. We assume that both standard and test antennas have been carefully matched to the appropriate impedance and an accurately calibrated and matched detecting device is being used.

A standard-gain antenna may be any type of unidirectional, preferably planar-aperture, antenna, which has been calibrated either by direct measurement or in special cases by accurate construction according to computed dimensions. A standard-gain antenna has been suggested by [Richard F. H. Yang](#) (see Bibliography). Shown in **Fig 63**, it consists of two in-phase dipoles  $\frac{1}{2} \lambda$  apart and backed up with a ground plane  $1 \lambda$  square.

In Yang's original design, the stub at the center is a balun formed by cutting two longitudinal slots of  $\frac{1}{8}$ -inch width, diametrically opposite, on a  $\frac{1}{4}$ - $\lambda$  section of  $\frac{7}{8}$ -inch rigid 50- $\Omega$  coax. An alternative method of feeding is to feed RG-8 or RG-213 coax through slotted  $\frac{7}{8}$ -inch copper tubing. Be sure to leave the outer jacket on the coax to insulate it from the copper-tubing balun section. When constructed accurately to scale for the frequency of interest, this type of standard will have an absolute gain of 9.85 dBi (7.7 dBd gain over a dipole in free space) with an accuracy of  $\pm 0.25$  dB.

## RADIATION-PATTERN MEASUREMENTS

Of all antenna measurements, the radiation pattern is the most demanding in measurement and the most difficult to interpret. Any antenna radiates to some degree in all directions into the space surrounding it. Therefore, the radiation pattern of an antenna is a three-dimensional representation of the magnitude, phase and polarization. In general, and in practical cases for Amateur Radio communications, the polarization is well defined and only the magnitude of radiation is important.

Furthermore, in many of these cases the radiation in one particular plane is of primary interest, usually the plane corresponding to that of the Earth's surface, regardless of polarization. Because of the nature of the range setup, measurement of radiation pattern can be successfully made only in a plane nearly parallel to the earth's surface. With beam antennas it is advisable and usually sufficient to take two radiation pattern measurements, one in the polarization plane and one at right angles to the plane of polarization. These radiation patterns are referred to in antenna literature as the principal E-plane and H-plane patterns, respectively. *E-plane* means parallel to the electric field that is the polarization plane and *H-plane* means parallel to the magnetic field in free space. The electric field and magnetic field are always perpendicular to each other in a plane wave as it propagates through space.

When the antenna is located over real earth, the terms *Azimuth* and *elevation* planes are commonly used, since the

frame of reference is the Earth itself, rather than the electric and magnetic fields in free space. For a horizontally polarized antenna such as a Yagi mounted with its elements parallel to the ground, the azimuth plane is the E-plane and the elevation plane is the H-plane.

The technique to obtain these patterns is simple in procedure but requires more equipment and patience than does making a gain measurement. First, a suitable mount is required that can be rotated in the azimuth plane (horizontal) with some degree of accuracy in terms of azimuth-angle positioning. Second, a signal-level indicator calibrated over at least a 20-dB dynamic range with a readout resolution of at least 2 dB is required. A dynamic range of up to about 40 dB would be desirable but does not add greatly to the measurement significance.

With this much equipment, the procedure is to locate first the area of maximum radiation from the beam antenna by carefully adjusting the azimuth and elevation positioning. These settings are then arbitrarily assigned an azimuth angle of zero degrees and a signal level of zero decibels. Next, without changing the elevation setting (tilt of the rotating axis), the antenna is carefully rotated in azimuth in small steps

that permit signal-level readout of 2 or 3 dB per step. These points of signal level corresponding with an azimuth angle are recorded and plotted on polar coordinate paper. A sample of the results is shown on ARRL coordinate paper in **Fig 64**.

On the sample radiation pattern the measured points are marked with an X and a continuous line is drawn in, since the pattern is a continuous curve. Radiation patterns should preferably be plotted on a logarithmic radial scale, rather than a voltage or power scale. The reason is that the log scale approximates the response of the ear to signals in the audio range. Also many receivers have AGC systems that are somewhat logarithmic in response; therefore the log scale is more representative of actual system operation.

Having completed a set of radiation-pattern measurements, one is prompted to ask, "Of what use are they?" The primary answer is as a diagnostic tool to determine if the antenna is functioning as it was intended to. A second answer is to know how the antenna will discriminate against interfering signals from various directions.

Consider now the diagnostic use of the radiation patterns. If the radiation beam is well defined, then there is an approximate formula relating the antenna gain to the measured half-power beamwidth of the E- and H-plane radiation patterns. The half-power beamwidth is indicated on the polar plot where the radiation level falls to 3 dB below the main beam 0-dB reference on either side. The formula is

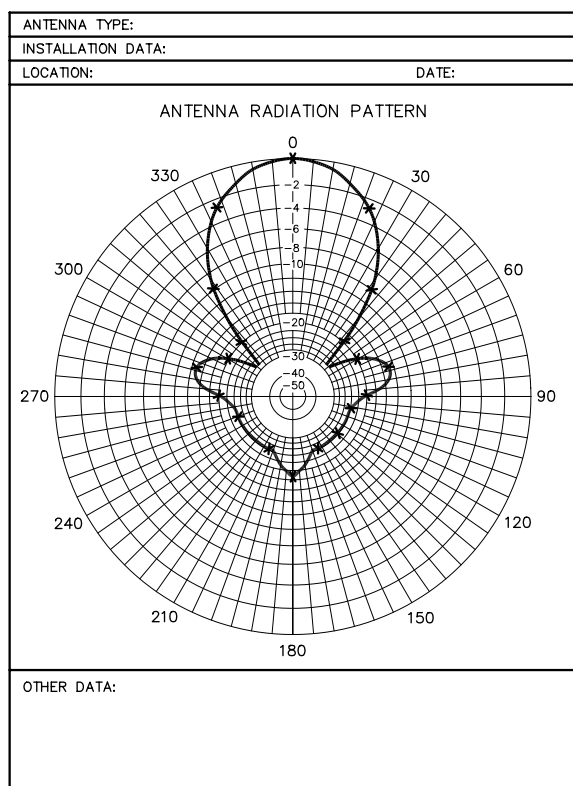
$$\text{Gain(dBi)} \cong \frac{41,253}{\theta_E \phi_H} \quad (\text{Eq 29})$$

where  $\theta_E$  and  $\phi_H$  are the half-power beamwidths in degrees of the E- and H-plane patterns, respectively. This equation assumes a lossless antenna system, where any sidelobes are well suppressed.

To illustrate the use of this equation, assume that we have a Yagi antenna with a boom length of two wavelengths. From known relations (described in [Chapter 11](#)) the expected free-space gain of a Yagi with a boom length of  $2 \lambda$  is about 13 dBi; its gain,  $G$ , equals 20. Using the above relationship, the product of  $\theta_E \times \phi_H \approx 2062$  square degrees. Since a Yagi produces a nearly symmetric beam shape in cross section,  $\theta_E = \phi_H = 45^\circ$ . Now if the measured values of  $\theta_E$  and  $\phi_H$  are much larger than  $45^\circ$ , then the gain will be much lower than the expected 13 dBi.

As another example, suppose that the same antenna (a 2-wavelength-boom Yagi) gives a measured gain of 9 dBi but the radiation pattern half power beamwidths are approximately  $45^\circ$ . This situation indicates that although the radiation patterns seem to be correct, the low gain shows inefficiency somewhere in the antenna, such as lossy materials or poor connections.

Large broadside collinear antennas can be checked for excessive phasing-line losses by comparing the gain computed from the radiation patterns with the direct-measured gain. It seems paradoxical, but it is indeed possible to build a large array with a very narrow beamwidth



For more information see QST, July 1980, p.26 Copyright 1980, ARRL Inc.

**Fig 64—Sample plot of a measured radiation pattern, using techniques described in the text. The plot is on coordinate paper available from ARRL HQ. The form provides space for recording significant data and remarks.**

indicating high gain, but actually having very low gain because of losses in the feed distribution system.

In general, and for most VHF/UHF Amateur Radio communications, gain is the primary attribute of an antenna. However, radiation in other directions than the main beam, called *sidelobe radiation*, should be examined by measurement of radiation patterns for effects such as nonsymmetry on either side of the main beam or excessive magnitude of sidelobes. (Any sidelobe that is less than 10 dB below the main beam reference level of 0 dB should be considered excessive.) These effects are usually attributable to incorrect phasing of the radiating elements or radiation from other parts of the antenna that was not intended, such as the support structure or feed line.

The interpretation of radiation patterns is intimately related to the particular type of antenna under measurement. Reference data should be consulted for the antenna type of interest, to verify that the measured results are in agreement with expected results.

To summarize the use of pattern measurements, if a beam antenna is first checked for gain (the easier measurement to make) and it is as expected, then pattern measurements may be academic. However, if the gain is lower than expected it is advisable to make pattern measurements to help determine the possible causes for low gain.

Regarding radiation pattern measurements, remember that the results measured under proper range facilities will not necessarily be the same as observed for the same antenna at a home-station installation. The reasons may be obvious now in view of the preceding information on the range setup, ground reflections, and the vertical-field distribution profiles. For long paths over rough terrain where many large obstacles may exist, the effects of ground reflection tend to become diffused, although they still can cause unexpected results. For these reasons it is usually unjust to compare VHF/UHF antennas over long paths.

## BIBLIOGRAPHY

Source material and more extended discussion of topics covered in this chapter can be found in the references given below.

- A. Bailey, "The Antenna Lab, Parts 1 and 2," *Radio Communication*, Aug and Sep 1983.
- L. Blake, *Transmission Lines and Waveguides* (New York: John Wiley & Sons, 1969), pp 244-251.
- J. H. Bowen, "A Calorimeter for VHF and UHF Power Measurements," *QST*, Dec 1975, pp 11-13.
- W. Bruene, "An Inside Picture of Directional Wattmeters," *QST*, April 1959.
- CCIR Recommendation 368*, Documents of the CCIR XII Plenary assembly, ITU, Geneva, 1967.
- J. Carr, "Fond Fault with Your Coax," 73, Oct 1984, pp 10-14.
- D. DeMaw, "In-Line RF Power Metering," *QST*, December 1969.
- D. Fayman, "A Simple Computing SWR Meter," *QST*,

Jul 1973, pp 23-33.

- J. Gibbons and H. Horn, "A Circuit With Logarithmic Response Over Nine Decades," *IEEE Transactions on Circuit Theory*, Vol CT-11, No. 3, Sep 1964, pp 378-384.
- J. Grebenkemper, "Calibrating Diode Detectors," *QEX*, Aug 1990.
- J. Grebenkemper, "The Tandem Match—An Accurate Directional Wattmeter," *QST*, Jan 1987.
- J. Grebenkemper, "Improving and Using R-X Noise Bridges," *QST*, Aug 1989; feedback, *QST*, Jan 1990, p 27.
- G. H. Hagn, SRI, "HF Ground Measurements at the Lawrence Livermore National Laboratory (LLNL) Field Site," *Applied Computational Electromagnetics Society Journal and Newsletter*, Vol 3, Number 2, Fall 1988.
- T. King, "A Practical Time-Domain Reflectometer," *QST*, May 1989, pp 22-24.
- Z. Lau and C. Hutchinson, "Improving the HW-9 Transceiver," *QST*, Apr 1988, pp 26-29.
- V. G. Leenerts, "Automatic VSWR and Power Meter," *Ham Radio*, May 1980, pp 34-43.
- J. Lenk, *Handbook of Oscilloscopes* (Englewood Cliffs, NJ: Prentice-Hall, 1982), pp 288-292.
- I. Lindell, E. Alanen, K. Mannerslo, "Exact Image Method for Impedance Computation of Antennas Above the Ground," *IEEE Trans. On Antennas and Propagation*, AP-33, Sep 1985.
- L. McCoy, "A Linear Field-Strength Meter," *QST*, January, 1973.
- T. McMullen, "The Line Sampler, an RF Power Monitor for VHF and UHF," *QST*, April 1972.
- M. Walter Maxwell, W2DU, *Reflections* (Newington: ARRL, 1990), p 20-3. [Out of print.]
- C. Michaels, "Determining Line Lengths," Technical Correspondence, *QST*, Sep 1985, pp 43-44.
- H. Perras, "Broadband Power-Tracking VSWR Bridge," *Ham Radio*, Aug 1979, pp 72-75.
- S. Ramo, J. Whinnery and T. Van Duzer, *Fields and Waves in Communication Electronics* (New York: John Wiley & Sons, 1967), Chap 1.
- Reference Data for Radio Engineers*, 5<sup>th</sup> edition (Indianapolis: Howard W. Sams, 1968), Chapter 28.
- P. N. Saveskie, *Radio Propagation Handbook* (Blue Ridge Summit, PA: TAB Books, 1960).
- J. Sevick, "Short Ground-Radial Systems for Short Verticals," *QST*, Apr 1978, pp 30-33.
- J. Sevick, "Measuring Soil Conductivity," *QST*, Mar 1981, pp 38-39.
- W. Spaulding, "A Broadband Two-Port S-Parameter Test Set," *Hewlett-Packard Journal*, Nov 1984.
- D. Turrin, "Antenna Performance Measurements," *QST*, Nov 1974, pp 35-41.
- F. Van Zant, "High-Power Operation with the Tandem Match Directional Coupler," Technical Correspondence, *QST*, Jul 1989, pp 42-43.
- R. F. H. Yang, "A Proposed Gain Standard for VHF Antennas," *IEEE Transactions on Antennas and Propagation*, Nov 1966.

# Chapter 28

# Smith Chart Calculations

The Smith Chart is a sophisticated graphic tool for solving transmission line problems. One of the simpler applications is to determine the feed-point impedance of an antenna, based on an impedance measurement at the input of a random length of transmission line. By using the Smith Chart, the impedance measurement can be made with the antenna in place atop a tower or mast, and there is no need to cut the line to an exact multiple of half wavelengths. The Smith Chart may be used for other purposes, too, such as the design of impedance-matching networks. These matching networks can take on any of several forms, such as L and pi networks, a stub matching system, a series-section match, and more. With a knowledge of the Smith Chart, the amateur can eliminate much “cut and try” work.

Named after its inventor, Phillip H. Smith, the Smith Chart was originally described in *Electronics* for January 1939. Smith Charts may be obtained at most university book stores. Smith Charts are also available from ARRL HQ. (See the caption for Fig 3.)

It is stated in Chapter 24 that the input impedance, or the impedance seen when “looking into” a length of line, is dependent upon the SWR, the length of the line, and the  $Z_0$  of the line. The SWR, in turn, is dependent upon the load which terminates the line. There are complex mathematical relationships which may be used to calculate the various values of impedances, voltages, currents, and SWR values that exist in the operation of a particular transmission line. These equations can be solved with a personal computer and suitable software, or the parameters may be determined with the Smith Chart. Even if a computer is used, a fundamental knowledge of the Smith Chart will promote a better understanding of the problem being solved. And such an understanding might lead to a quicker or simpler solution than otherwise. If the terminating impedance is known, it is a simple matter to determine the input impedance of the line for any length by means of the chart. Conversely, as indicated above, with a given line length and a known (or measured) input impedance, the load impedance may be determined by means of the chart—a convenient method of remotely determining an antenna impedance, for example.

Although its appearance may at first seem somewhat formidable, the Smith Chart is really nothing more than a

specialized type of graph. Consider it as having curved, rather than rectangular, coordinate lines. The coordinate system consists simply of two families of circles—the resistance family, and the reactance family. The resistance circles, Fig 1, are centered on the resistance axis (the only straight line on the chart), and are tangent to the outer circle at the right of the chart. Each circle is assigned a value of resistance, which is indicated at the point where the circle crosses the resistance axis. All points along any one circle have the same resistance value.

The values assigned to these circles vary from zero at the left of the chart to infinity at the right, and actually represent a *ratio* with respect to the impedance value assigned to the center point of the chart, indicated 1.0. This center point is called prime center. If prime center is assigned a value of 100  $\Omega$ , then 200  $\Omega$  resistance is represented by the 2.0 circle, 50  $\Omega$  by the 0.5 circle, 20  $\Omega$  by the 0.2 circle, and so on. If, instead, a value of 50 is assigned to prime center, the 2.0 circle now represents 100  $\Omega$ , the 0.5 circle 25  $\Omega$ , and the 0.2 circle 10  $\Omega$ . In each case, it may be seen that the value on the chart is determined by dividing the actual resistance by the number assigned to prime center.

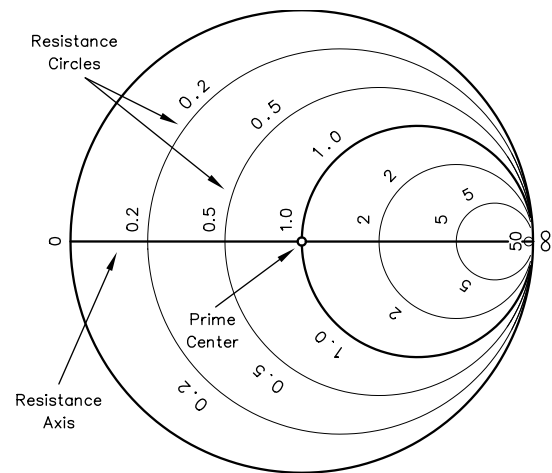


Fig 1—Resistance circles of the Smith Chart coordinate system.

This process is called normalizing.

Conversely, values from the chart are converted back to actual resistance values by multiplying the chart value times the value assigned to prime center. This feature permits the use of the Smith Chart for any impedance values, and therefore with any type of uniform transmission line, whatever its impedance may be. As mentioned above, specialized versions of the Smith Chart may be obtained with a value of 50 Ω at prime center. These are intended for use with 50-Ω lines.

Now consider the reactance circles, **Fig 2**, which appear as curved lines on the chart because only segments of the complete circles are drawn. These circles are tangent to the resistance axis, which itself is a member of the reactance family (with a radius of infinity). The centers are displaced to the top or bottom on a line tangent to the right of the chart. The large outer circle bounding the coordinate portion of the chart is the reactance axis.

Each reactance circle segment is assigned a value of reactance, indicated near the point where the circle touches the reactance axis. All points along any one segment have the same reactance value. As with the resistance circles, the values assigned to each reactance circle are normalized with respect to the value assigned to prime center. Values to the top of the resistance axis are positive (inductive), and those to the bottom of the resistance axis are negative (capacitive).

When the resistance family and the reactance family of circles are combined, the coordinate system of the Smith Chart results, as shown in **Fig 3**. Complex impedances ( $R + jX$ ) can be plotted on this coordinate system.

### IMPEDANCE PLOTTING

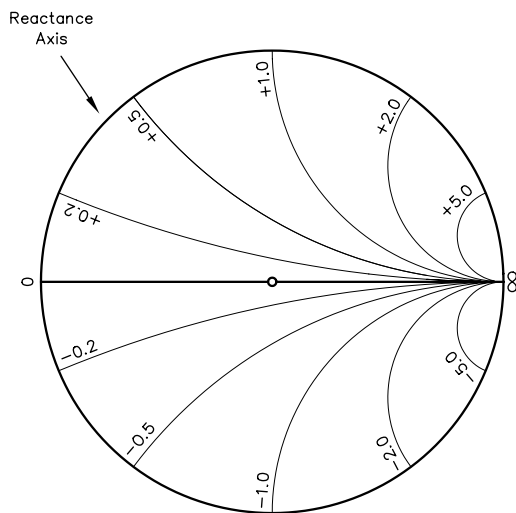
Suppose we have an impedance consisting of 50 Ω resistance and 100 Ω inductive reactance ( $Z = 50 + j100$ ).

If we assign a value of 100 Ω to prime center, we normalize the above impedance by dividing each component of the impedance by 100. The normalized impedance is then  $50/100 + j(100/100) = 0.5 + j1.0$ . This impedance is plotted on the Smith Chart at the intersection of the 0.5 resistance circle and the +1.0 reactance circle, as indicated in **Fig 3**. Calculations may now be made from this plotted value.

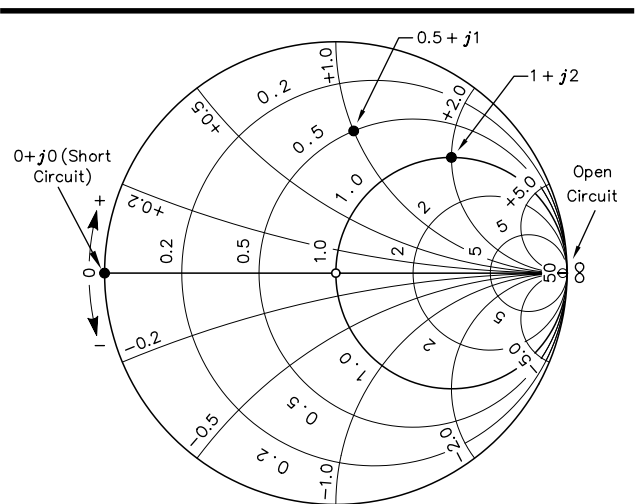
Now say that instead of assigning 100 Ω to prime center, we assign a value of 50 Ω. With this assignment, the  $50 + j100$  Ω impedance is plotted at the intersection of the  $50/50 = 1.0$  resistance circle, and the  $100/50 = 2.0$  positive reactance circle. This value,  $1 + j2$ , is also indicated in **Fig 3**. But now we have *two* points plotted in **Fig 3** to represent the same impedance value,  $50 + j100$  Ω. How can this be?

These examples show that the same impedance may be plotted at different points on the chart, depending upon the value assigned to prime center. But two plotted points cannot represent the same impedance *at the same time*! It is customary when solving transmission-line problems to assign to prime center a value equal to the characteristic impedance, or  $Z_0$ , of the line being used. This value should always be recorded at the start of calculations, to avoid possible confusion later. (In using the specialized charts with the value of 50 at prime center, it is, of course, not necessary to normalize impedances when working with 50-Ω line. The resistance and reactance values may be read directly from the chart coordinate system.)

Prime center is a point of special significance. As just mentioned, it is customary when solving problems to assign the  $Z_0$  value of the line to this point on the chart—50 Ω for a 50-Ω line, for example. What this means is that the center point of the chart now represents  $50 + j0$  ohms—a pure



**Fig 2**—Reactance circles (segments) of the Smith Chart coordinate system.



**Fig 3**—The complete coordinate system of the Smith Chart. For simplicity, only a few divisions are shown for the resistance and reactance values. Various types of Smith Chart forms are available from ARRL HQ. At the time of this writing, five 8½ × 11 inch Smith Chart forms are available for \$2.

resistance equal to the characteristic impedance of the line. If this were a load on the line, we recognize from transmission-line theory that it represents a perfect match, with no reflected power and with a 1.0 to 1 SWR. Thus, prime center also represents the 1.0 SWR circle (with a radius of zero). SWR circles are also discussed in a later section.

### Short and Open Circuits

On the subject of plotting impedances, two special cases deserve consideration. These are short circuits and open circuits. A true short circuit has zero resistance and zero reactance, or  $0 + j0$ . This impedance is plotted at the left of the chart, at the intersection of the resistance and the reactance axes. By contrast, an open circuit has infinite resistance, and therefore is plotted at the right of the chart, at the intersection of the resistance and reactance axes. These two special cases are sometimes used in matching stubs, described later.

### Standing-Wave-Ratio Circles

Members of a third family of circles, which are not printed on the chart but which are added during the process of solving problems, are standing-wave-ratio or SWR circles. See Fig 4. This family is centered on prime center, and appears as concentric circles inside the reactance axis. During calculations, one or more of these circles may be added with a drawing compass. Each circle represents a value of SWR, with every point on a given circle representing the same SWR. The SWR value for a given circle may be determined directly from the chart coordinate system, by reading the resistance value where the SWR circle crosses the resistance axis to the right of prime center. (The reading where the circle crosses the resistance axis to the left of prime center indicates the inverse ratio.)

Consider the situation where a load mismatch in a length of line causes a 3-to-1 SWR ratio to exist. If we temporarily disregard line losses, we may state that the SWR remains constant throughout the entire length of this line. This is represented on the Smith Chart by drawing a 3:1 constant SWR circle (a circle with a radius of 3 on the resistance axis), as in Fig 5. The design of the chart is such that any impedance encountered *anywhere* along the length of this mismatched line will fall on the SWR circle. The impedances may be read from the coordinate system merely by the progressing around the SWR circle by an amount corresponding to the length of the line involved.

This brings into use the wavelength scales, which appear in Fig 5 near the perimeter of the Smith Chart. These scales are calibrated in terms of portions of an electrical wavelength along a transmission line. Both scales start from 0 at the left of the chart. One scale, running

counterclockwise, starts at the generator or input end of the line and progresses toward the load. The other scale starts at the load and proceeds toward the generator in a clockwise direction. The complete circle around the edge of the chart represents  $1/2 \lambda$ . Progressing once around the perimeter of

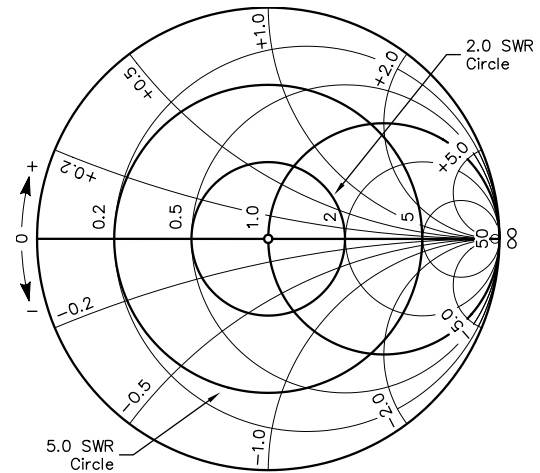


Fig 4—Smith Chart with SWR circles added.

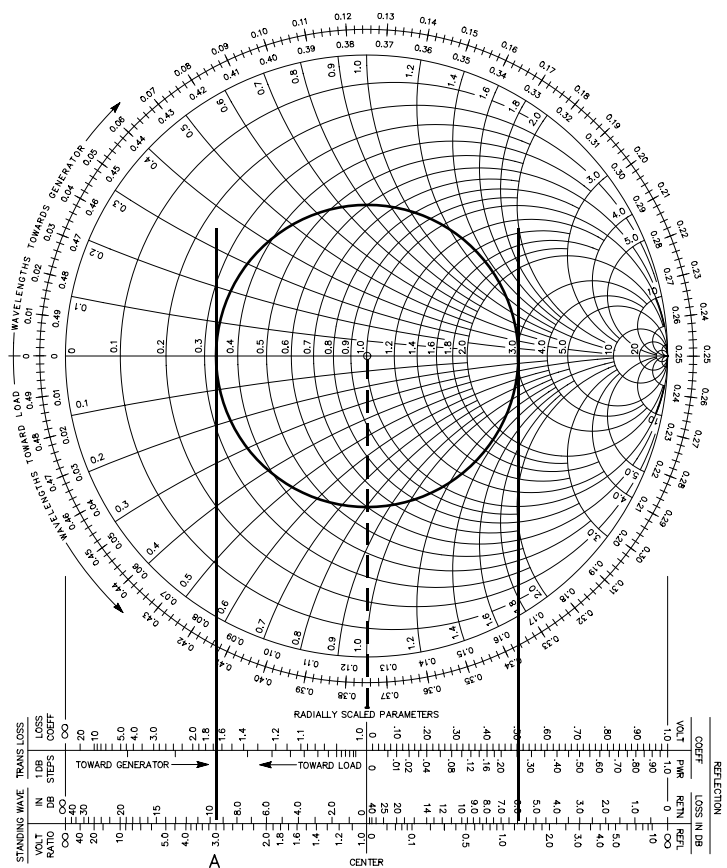


Fig 5—Example discussed in text.

these scales corresponds to progressing along a transmission line for  $\frac{1}{2} \lambda$ . Because impedances repeat themselves every  $\frac{1}{2} \lambda$  along a piece of line, the chart may be used for any length of line by disregarding or subtracting from the line's total length an integral, or whole number, of half wavelengths.

Also shown in Fig 5 is a means of transferring the radius of the SWR circle to the external scales of the chart, by drawing lines tangent to the circle. Another simple way to obtain information from these external scales is to transfer the radius of the SWR circle to the external scale with a drawing compass. Place the point of a drawing compass at the center or 0 line, and inscribe a short arc across the appropriate scale. It will be noted that when this is done in Fig 5, the external STANDING-WAVE VOLTAGE-RATIO scale indicates the SWR to be 3.0 (at A)—our condition for initially drawing the circle on the chart (and the same as the SWR reading on the resistance axis).

### SOLVING PROBLEMS WITH THE SMITH CHART

Suppose we have a transmission line with a characteristic impedance of  $50 \Omega$  and an electrical length of  $0.3 \lambda$ . Also, suppose we terminate this line with an impedance having a resistive component of  $25 \Omega$  and an inductive reactance of  $25 \Omega$  ( $Z = 25 + j25$ ). What is the input impedance to the line?

The characteristic impedance of the line is  $50 \Omega$ , so we begin by assigning this value to prime center. Because the line is not terminated in its characteristic impedance, we know that standing waves will exist on the line, and that, therefore, the input impedance to the line will not be exactly  $50 \Omega$ . We proceed as follows. First, normalize the load impedance by dividing both the resistive and reactive components by 50 ( $Z_0$  of the line being used). The normalized impedance in this case is  $0.5 + j0.5$ . This is plotted on the chart at the intersection of the 0.5 resistance and the  $+0.5$  reactance circles, as in Fig 6. Then draw a constant SWR circle passing through this point. Transfer the radius of this circle to the external scales with the drawing compass. From the external STANDING-WAVE VOLTAGE-RATIO scale, it may be seen (at A) that the voltage ratio of 2.62 exists for this radius, indicating that our line is operating with an SWR of 2.62 to 1. This figure is converted to decibels in the adjacent scale, where 8.4 dB may be read (at B), indicating that the ratio of the voltage maximum to the voltage minimum along the line is 8.4 dB. (This is mathematically equivalent to 20 times the log of the SWR value.)

Next, with a straightedge, draw a radial line from prime center through the plotted point to intersect the wavelengths scale. At this intersection, point C in Fig 6, read a value from the wavelengths scale. Because we are starting

from the load, we use the TOWARD GENERATOR or outermost calibration, and read  $0.088 \lambda$ .

To obtain the line input impedance, we merely find the point on the SWR circle that is  $0.3 \lambda$  toward the generator from the plotted load impedance. This is accomplished by adding 0.3 (the length of the line in wavelengths) to the reference or starting point,  $0.088$ ;  $0.3 + 0.088 = 0.388$ . Locate  $0.388$  on the TOWARD GENERATOR scale (at D). Draw a second radial line from this point to prime center. The intersection of the new radial line with the SWR circle represents the normalized line input impedance, in this case  $0.6 - j0.66$ .

To find the unnormalized line impedance, multiply by 50, the value assigned to prime center. The resulting value is  $30 - j33$ , or  $30 \Omega$  resistance and  $33 \Omega$  capacitive reactance. This is the impedance that a transmitter must match if such a system were a combination of antenna and transmission line. This is also the impedance that would be measured on an impedance bridge if the measurement were taken at the line input.

In addition to the line input impedance and the SWR, the chart reveals several other operating characteristics of the above system of line and load, if a closer look is desired. For example, the voltage reflection coefficient, both

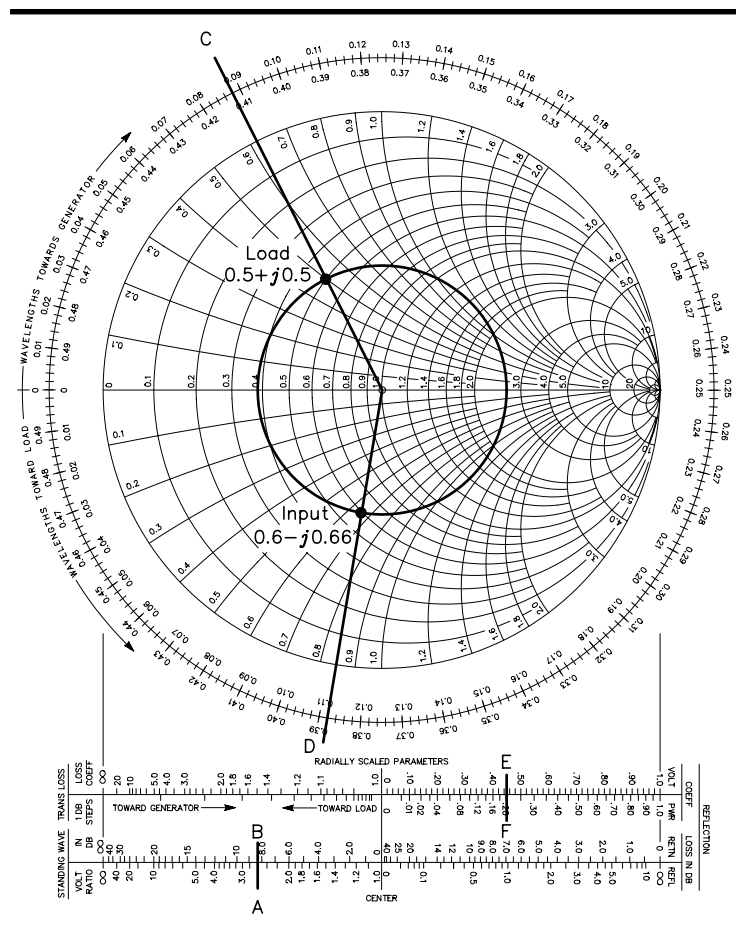


Fig 6—Example discussed in text.



magnitude and phase angle, for this particular load is given. The phase angle is read under the radial line drawn through the plot of the load impedance, where the line intersects the ANGLE OF REFLECTION COEFFICIENT scale. This scale is not included in Fig 6, but will be found on the Smith Chart just inside the wavelengths scales. In this example, the reading is 116.6 degrees. This indicates the angle by which the reflected voltage wave leads the incident wave at the load. It will be noted that angles on the bottom half, or capacitive-reactance half, of the chart are negative angles, a “negative” lead indicating that the reflected voltage wave actually lags the incident wave.

The magnitude of the voltage-reflection-coefficient may be read from the external REFLECTION COEFFICIENT VOLTAGE scale, and is seen to be approximately 0.45 (at E) for this example. This means that 45 percent of the incident voltage is reflected. Adjacent to this scale on the POWER calibration, it is noted (at F) that the power reflection coefficient is 0.20, indicating that 20 percent of the incident power is reflected. (The amount of reflected power is proportional to the square of the reflected voltage.)

### ADMITTANCE COORDINATES

Quite often it is desirable to convert impedance information to admittance data—conductance and susceptance. Working with admittances greatly simplifies determining the resultant when two complex impedances are connected in parallel, as in stub matching. The conductance values may be added directly, as may be the susceptance values, to arrive at the overall admittance for the parallel combination. This admittance may then be converted back to impedance data, if desired.

On the Smith Chart, the necessary conversion may be made very simply. The equivalent admittance of a plotted impedance value lies diametrically opposite the impedance point on the chart. In other words, an impedance plot and its corresponding admittance plot will lie on a straight line that passes through prime center, and each point will be the same distance from prime center (on the same SWR circle). In the above example, where the normalized line input impedance is  $0.6 - j0.66$ , the equivalent admittance lies at the intersection of the SWR circle and the extension of the straight line passing from point D through prime center. Although not shown in Fig 6, the normalized admittance value may be read as  $0.76 + j0.84$  if the line starting at D is extended.

In making impedance-admittance conversions, remember that capacitance is considered to be a positive susceptance and inductance a negative susceptance. This corresponds to the scale identification printed

on the chart. The admittance in siemens is determined by dividing the normalized values by the  $Z_0$  of the line. For this example the admittance is  $0.76/50 + j0.84/50 = 0.0152 + j0.0168$  siemen. Of course admittance coordinates may be converted to impedance coordinates just as easily—by locating the point on the Smith Chart that is diametrically opposite that representing the admittance coordinates, on the same SWR circle.

### DETERMINING ANTENNA IMPEDANCES

To determine an antenna impedance from the Smith Chart, the procedure is similar to the previous example. The electrical length of the feed line must be known and the impedance value at the input end of the line must be determined through measurement, such as with an impedance-measuring or a good quality noise bridge. In this case, the antenna is connected to the far end of the line and becomes the load for the line. Whether the antenna is intended purely for transmission of energy, or purely for reception makes no difference; the antenna is still the terminating or load impedance on the line as far as these measurements are concerned. The input or generator end of the line is that end connected to the device for measurement of the impedance. In this type of problem, the measured impedance is plotted on the chart, and the TOWARD LOAD

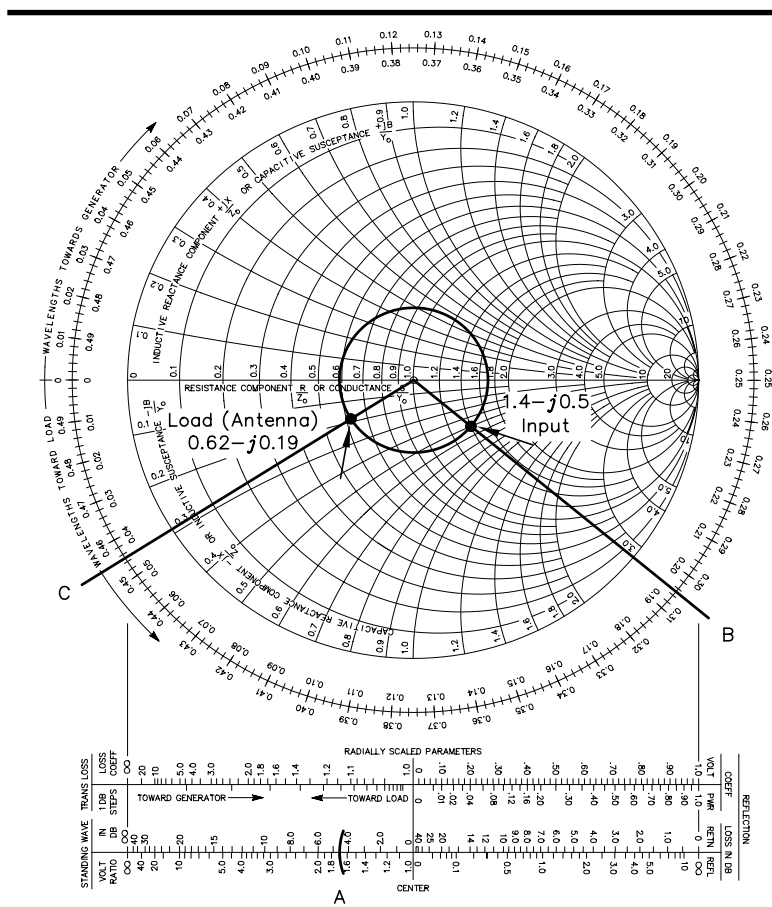


Fig 7—Example discussed in text.

wavelengths scale is used in conjunction with the electrical line length to determine the actual antenna impedance.

For example, assume we have a measured input impedance to a 50- $\Omega$  line of  $70 - j25 \Omega$ . The line is  $2.35 \lambda$  long, and is terminated in an antenna. What is the antenna feed impedance? Normalize the input impedance with respect to 50  $\Omega$ , which comes out  $1.4 - j0.5$ , and plot this value on the chart. See Fig 7. Draw a constant SWR circle through the point, and transfer the radius to the external scales. The SWR of 1.7 may be read from the VOLTAGE RATIO scale (at A). Now draw a radial line from prime center through this plotted point to the wavelengths scale, and read a reference value (at B). For this case the value is 0.195, on the TOWARD LOAD scale. Remember, we are starting at the generator end of the transmission line.

To locate the load impedance on the SWR circle, add the line length,  $2.35 \lambda$ , to the reference value from the wavelengths scale;  $2.35 + 0.195 = 2.545$ . Locate the new value on the TOWARD LOAD scale. But because the calibrations extend only from 0 to 0.5, we must first subtract a number of half wavelengths from this value and use only the remaining value. In this situation, the largest integral number of half wavelengths that can be subtracted with a positive result is 5, or  $2.5 \lambda$ . Thus,  $2.545 - 2.5 = 0.045$ . Locate the 0.045 value on the TOWARD LOAD scale (at C). Draw a radial line from this value to prime center. Now, the coordinates at the intersection of the second radial line and the SWR circle represent the load impedance. To read this value closely, some interpolation between the printed coordinate lines must be made, and the value of  $0.62 - j0.19$  is read. Multiplying by 50, we get the actual load or antenna impedance as  $31 - j9.5 \Omega$ , or 31  $\Omega$  resistance with 9.5  $\Omega$  capacitive reactance.

Problems may be entered on the chart in yet another manner. Suppose we have a length of 50- $\Omega$  line feeding a base-loaded resonant vertical ground-plane antenna which is shorter than  $1/4 \lambda$ . Further, suppose we have an SWR monitor in the line, and that it indicates an SWR of 1.7 to 1. The line is known to be  $0.95 \lambda$  long. We want to know both the input and the antenna impedances.

From the information available, we have no impedances to enter into the chart. We may, however, draw a circle representing the 1.7 SWR. We also know, from the definition of resonance, that the antenna presents a purely resistive load to the line, that is, no reactive component. Thus, the

antenna impedance must lie on the resistance axis. If we were to draw such an SWR circle and observe the chart with only the circle drawn, we would see two points which satisfy the resonance requirement for the load. These points are  $0.59 + j0$  and  $1.7 + j0$ . Multiplying by 50, we see that these values represent 29.5 and 85  $\Omega$  resistance. This may sound familiar, because, as was discussed in Chapter 24, when a line is terminated in a pure resistance, the SWR in the line equals  $Z_R/Z_0$  or  $Z_0/Z_R$ , where  $Z_R$ =load resistance and  $Z_0$ =line impedance.

If we consider antenna fundamentals described in Chapter 2, we know that the theoretical impedance of a  $1/4$ - $\lambda$  ground-plane antenna is approximately 36  $\Omega$ . We therefore can quite logically discard the 85- $\Omega$  impedance figure in favor of the 29.5- $\Omega$  value. This is then taken as the load impedance value for the Smith Chart calculations. To find the line input impedance, we subtract  $0.5 \lambda$  from the line length, 0.95, and find 0.45  $\lambda$  on the TOWARD GENERATOR scale. (The wavelength-scale starting point in this case is 0.) The line input impedance is found to be  $0.63 - j0.20$ , or  $31.5 - j10 \Omega$ .

### DETERMINATION OF LINE LENGTH

In the example problems given so far in this chapter, the line length has conveniently been stated in wavelengths. The electrical length of a piece of line depends upon its physical length, the radio frequency under consideration, and the velocity of propagation in the line. If an impedance-measurement bridge is capable of quite reliable readings at high SWR values, the line length may be determined through line input-impedance measurements with short- or open-circuit line terminations. Information on the procedure is given later in this chapter. A more direct method is to measure the physical length of the line and calculate its electrical length from

$$N = \frac{Lf}{984 VF} \quad (\text{Eq 1})$$

where

$N$  = number of electrical wavelengths in the line

$L$  = line length in feet

$f$  = frequency, MHz

$VF$  = velocity or propagation factor of the line

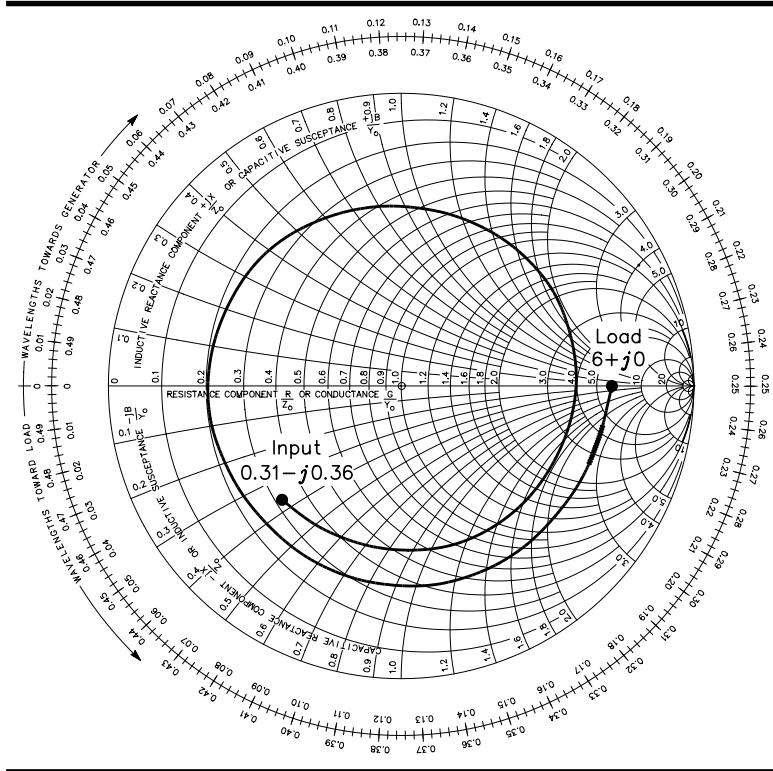
The velocity factor may be obtained from transmission-line data tables in Chapter 24.

## Line-Loss Considerations with the Smith Chart

The example Smith Chart problems presented in the previous section ignored attenuation, or line losses. Quite frequently it is not even necessary to consider losses when making calculations; any difference in readings obtained are often imperceptible on the chart. However, when the line losses become appreciable, such as for high-loss lines, long

lines, or at VHF and UHF, loss considerations may become significant in making Smith Chart calculations. This involves only one simple step, in addition to the procedures previously presented.

Because of line losses, as discussed in Chapter 24 the SWR does not remain constant throughout the length of the



**Fig 8**—This spiral is the actual “SWR circle” when line losses are taken into account. It is based on calculations for a 16-ft length of RG-174 coax feeding a resonant 28-MHz 300-Ω antenna (50-Ω coax, velocity factor = 66%, attenuation = 6.2 dB per 100 ft). The SWR at the load is 6:1, while it is 3.6:1 at the line input. When solving problems involving attenuation, two constant SWR circles are drawn instead of a spiral, one for the line input SWR and one for the load SWR.

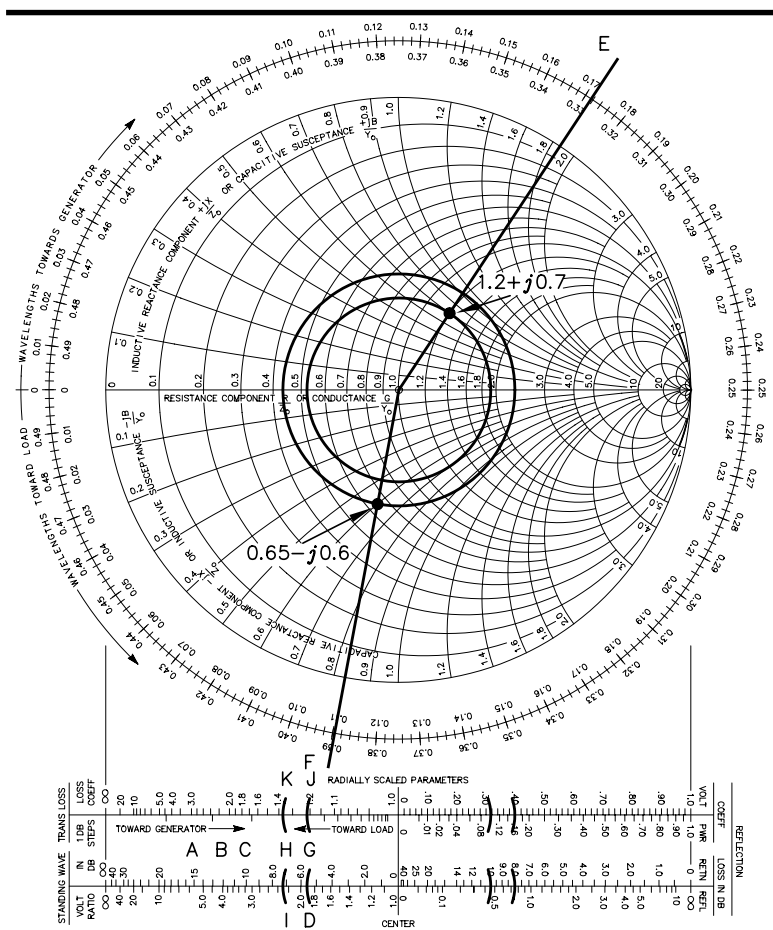
line. As a result, there is a decrease in SWR as one progresses away from the load. To truly present this situation on the Smith Chart, instead of drawing a constant SWR circle, it would be necessary to draw a spiral inward and clockwise from the load impedance toward the generator, as shown in **Fig 8**. The rate at which the curve spirals toward prime center is related to the attenuation in the line. Rather than drawing spiral curves, a simpler method is used in solving line-loss problems, by means of the external scale TRANSMISSION LOSS 1-DB STEPS. This scale may be seen in **Fig 9**. Because this is only a relative scale, the decibel steps are not numbered.

If we start at the left end of this external scale and proceed in the direction indicated TOWARD GENERATOR, the first dB step is seen to occur at a radius from center corresponding to an SWR of about 9 (at A); the second dB step falls at an SWR of about 4.5 (at B), the third at 3.0 (at C), and so forth, until the 15th dB step falls at an SWR of about 1.05 to 1. This means that a line terminated in a short or open circuit (infinite SWR), and having an attenuation of 15 dB, would exhibit an SWR of only 1.05 at its input. It will be noted that the dB steps near the right end of the scale are very close together, and a line attenuation of 1 or 2 dB in this area will have only slight effect on the SWR. But near the left end of the scale, corresponding to high SWR values, a 1 or 2 dB loss has considerable effect on the SWR.

### Using a Second SWR Circle

In solving a problem using line-loss information, it is necessary only to modify the radius of the SWR circle by an amount indicated on the TRANSMISSION-LOSS 1-DB STEPS scale. This is accomplished by drawing a second SWR circle, either smaller or larger than the first, depending on whether you are working toward the load or toward the generator.

For example, assume that we have a 50-Ω line that is 0.282 λ long, with 1-dB inherent attenuation. The line input impedance is



**Fig 9**—Example of Smith Chart calculations taking line losses into account.

measured as  $60 + j35 \Omega$ . We desire to know the SWR at the input and at the load, and the load impedance. As before, we normalize the  $60 + j35\text{-}\Omega$  impedance, plot it on the chart, and draw a constant SWR circle and a radial line through the point. In this case, the normalized impedance is  $1.2 + j0.7$ . From Fig 9, the SWR at the line input is seen to be 1.9 (at D), and the radial line is seen to cross the TOWARD LOAD scale, first subtract 0.500, and locate 0.110 (at F); then draw a radial line from this point to prime center.

To account for line losses, transfer the radius of the SWR circle to the external 1-DB STEPS scale. This radius crosses the external scale at G, the fifth decibel mark from the left. Since the line loss was given as 1 dB, we strike a new radius (at H), one “tick mark” to the left (toward load) on the same scale. (This will be the fourth decibel tick mark from the left of the scale.) Now transfer this new radius back to the main chart, and scribe a new SWR circle of this radius. This new radius represents the SWR at the load, and is read as 2.3 on the external VOLTAGE RATIO scale. At the intersection of the new circle and the load radial line, we read  $0.65 - j0.6$ . This is the normalized load impedance. Multiplying by 50, we obtain the actual load impedance as  $32.5 - j30 \Omega$ . The SWR in this problem was seen to increase from 1.9 at the line input to 2.3 (at I) at the load, with the 1-dB line loss taken into consideration.

In the example above, values were chosen to fall conveniently on or very near the “tick marks” on the 1-dB scale. Actually, it is a simple matter to interpolate between these marks when making a radius correction. When this is necessary, the relative distance between marks for each decibel step should be maintained while counting off the proper number of steps.

Adjacent to the 1-DB STEPS scale lies a LOSS COEFFICIENT scale. This scale provides a factor by which the matched-line loss in decibels should be multiplied to account for the increased losses in the line when standing waves are present. These added losses do not affect the SWR or impedance calculations; they are merely the additional dielectric copper losses of the line caused by the fact that the line conducts more average voltage in the presence of standing waves. For the above example, from Fig 9, the loss coefficient at the input end is seen to be 1.21 (at J), and 1.39 (at K) at the load. As a good approximation, the loss coefficient may be averaged over the length of line under consideration; in this case, the average is 1.3. This means that the total losses in the line are 1.3 times the matched loss of the line (1 dB), or 1.3 dB. This is the same result that may be obtained from procedures given in Chapter 24 for this data.

### Smith Chart Procedure Summary

To summarize briefly, any calculations made on the Smith Chart are performed in four basic steps, although not necessarily in the order listed.

- 1) Normalize and plot a line input (or load) impedance, and construct a constant SWR circle.
- 2) Apply the line length to the wavelengths scales.

- 3) Determine attenuation or loss, if required, by means of a second SWR circle.
- 4) Read normalized load (or input) impedance, and convert to impedance in ohms.

The Smith Chart may be used for many types of problems other than those presented as examples here. The transformer action of a length of line—to transform a high impedance (with perhaps high reactance) to a purely resistive impedance of low value—was not mentioned. This is known as “tuning the line,” for which the chart is very helpful, eliminating the need for “cut and try” procedures. The chart may also be used to calculate lengths for shorted or open matching stubs in a system, described later in this chapter. In fact, in any application where a transmission line is not perfectly matched, the Smith Chart can be of value.

## ATTENUATION AND $Z_0$ FROM IMPEDANCE MEASUREMENTS

If an impedance bridge is available to make accurate measurements in the presence of very high SWR values, the attenuation, characteristic impedance and velocity factor of any random length of coaxial transmission line can be determined. This section was written by Jerry Hall, K1TD.

Homemade impedance bridges and noise bridges will seldom offer the degree of accuracy required to use this technique, but sometimes laboratory bridges can be found as industrial surplus at a reasonable price. It may also be possible for an amateur to borrow a laboratory type of bridge for the purpose of making some weekend measurements. Making these determinations is not difficult, but the procedure is not commonly known among amateurs. One equation treating complex numbers is used, but the math can be handled with a calculator supporting trig functions. Full details are given in the paragraphs that follow.

For each frequency of interest, two measurements are required to determine the line impedance. Just one measurement is used to determine the line attenuation and velocity factor. As an example, assume we have a 100-foot length of unidentified line with foamed dielectric, and wish to know its characteristics. We make our measurements at 7.15 MHz. The procedure is as follows.

- 1) Terminate the line in an open circuit. The best “open circuit” is one that minimizes the capacitance between the center conductor and the shield. If the cable has a PL-259 connector, unscrew the shell and slide it back down the coax for a few inches. If the jacket and insulation have been removed from the end, fold the braid back along the outside of the line, away from the center conductor.
- 2) Measure and record the impedance at the input end of the line. If the bridge measures admittance, convert the measured values to resistance and reactance. Label the values as  $R_{oc} + jX_{oc}$ . For our example, assume we measure  $85 + j179 \Omega$ . (If the reactance term is capacitive, record it as negative.)
- 3) Now terminate the line in a short circuit. If a connector exists at the far end of the line, a simple short is a mating



capacitance presents a path for current to flow at the RF measurement frequency.)

Use the Smith Chart and the 1-DB STEPS external scale to find line attenuation. First normalize the short circuit impedance reading to the calculated  $Z_0$ , and plot this point on the chart. See Fig 10. For our example, the normalized impedance is  $4.8/49.1 - j11.2 / 49.1$  or  $0.098 - j0.228$ . After plotting the point, transfer the radius to the 1-DB STEPS scale. This is shown at A of Fig 10.

Remember from discussions earlier in this chapter that the impedance for plotting a short circuit is  $0 + j0$ , at the left edge of the chart on the resistance axis. On the 1-DB STEPS scale this is also at the left edge. The total attenuation in the line is represented by the number of dB steps from the left edge to the radius mark we have just transferred. For this example it is 0.8 dB. Some estimation may be required in interpolating between the 1-dB step marks.

### Determining Velocity Factor

The velocity factor is determined by using the TOWARD GENERATOR wavelength scale of the Smith Chart. With a straightedge, draw a line from prime center through the point representing the short-circuit reading, until it intersects the wavelengths scale. In Fig 10 this point is labeled B. Consider that during our measurement, the short circuit was the load at the end of the line. Imagine a spiral curve progressing from  $0 + j0$  clockwise and inward to our plotted measurement point. The wavelength scale, at B, indicates this line length is  $0.464 \lambda$ . By rearranging the terms of Eq 1 given early in this chapter, we arrive at an equation for calculating the velocity factor.

$$VF = \frac{Lf}{984N} \quad (\text{Eq 4})$$

where

VF = velocity factor

L = line length, feet

f = frequency, MHz

N = number of electrical wavelengths in the line

Inserting the example values into Eq 4 yields  $VF = 100 \times 7.15 / (984 \times 0.464) = 1.566$ , or 156.6%. Of course, this value is an impossible number—the velocity factor in coax cannot be greater than 100%. But remember, the Smith Chart can be used for lengths greater than  $1/2 \lambda$ . Therefore, that 0.464 value could rightly be 0.964, 1.464, 1.964, and so on. When using  $0.964 \lambda$ , Eq 4 yields a velocity factor of 0.753, or 75.3%. Trying successively greater values for the wavelength results in velocity factors of 49.6 and 37.0%. Because the cable we measured had foamed dielectric, 75.3% is the probable velocity factor. This corresponds to an electrical length of  $0.964 \lambda$ . Therefore, we have determined from the measurements and calculations that our unmarked coax has a

nominal 50-Ω impedance, an attenuation of 0.8 dB per hundred feet at 7.15 MHz, and a velocity factor of 75.3%.

It is difficult to use this procedure with short lengths of coax, just a few feet. The reason is that the SWR at the line input is too high to permit accurate measurements with most impedance bridges. In the example above, the SWR at the line input is approximately 12:1.

The procedure described above may also be used for determining the characteristics of balanced lines. However, impedance bridges are generally unbalanced devices, and the procedure for measuring a balanced impedance accurately with an unbalanced bridge is complicated.

### LINES AS CIRCUIT ELEMENTS

Information is presented in Chapter 24 on the use of transmission-line sections as circuit elements. For example, it is possible to substitute transmission lines of the proper length and termination for coils or capacitors in ordinary circuits. While there is seldom a practical need for that application, lines are frequently used in antenna systems in place of lumped components to tune or resonate elements. Probably the most common use of such a line is in the hairpin match, where a short section of stiff open-wire line acts as a lumped inductor.

The equivalent “lumped” value for any “inductor” or “capacitor” may be determined with the aid of the Smith Chart. Line losses may be taken into account if desired, as explained earlier. See Fig 11. Remember that the top half

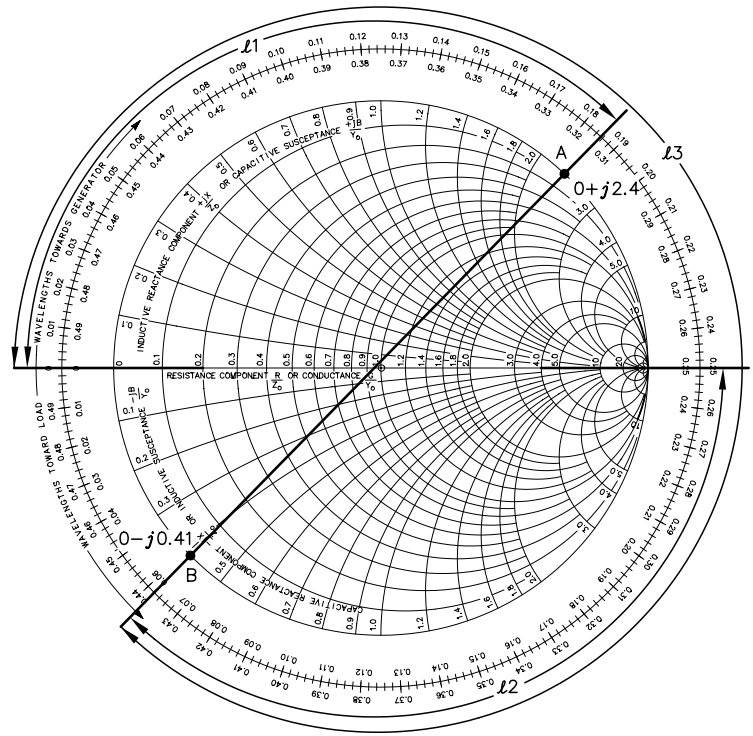


Fig 11—Smith Chart determination of input impedances for short- and open-circuited line sections, disregarding line losses.

of the Smith Chart coordinate system is used for impedances containing inductive reactances, and the bottom half for capacitive reactances. For example, a section of 600- $\Omega$  line  $3/16\lambda$  long ( $0.1875\lambda$ ) and short-circuited at the far end is represented by  $\ell_1$ , drawn around a portion of the perimeter of the chart. The “load” is a short-circuit,  $0 + j0\ \Omega$ , and the TOWARD GENERATOR wavelengths scale is used for marking off the line length. At A in Fig 11 may be read the normalized impedance as seen looking into the length of line,  $0 + j2.4$ . The reactance is therefore inductive, equal to  $600 \times 2.4 = 1440\ \Omega$ . The same line when open-circuited (termination

impedance =  $\infty$ , the point at the right of the chart) is represented by  $\ell_2$  in Fig 11. At B the normalized line-input impedance may be read as  $0 - j0.41$ ; the reactance in this case is capacitive,  $600 \times 0.41 = 246\ \Omega$ . (Line losses are disregarded in these examples.) From Fig 11 it is easy to visualize that if  $\ell_1$  were to be extended by  $1/4\lambda$ , the total length represented by  $\ell_3$ , the line-input impedance would be identical to that obtained in the case represented by  $\ell_2$  alone. In the case of  $\ell_2$ , the line is open-circuited at the far end, but in the case of  $\ell_3$  the line is terminated in a short. The added section of line for  $\ell_3$  provides the “transformer action” for which the  $1/4\lambda$  line is noted.

The equivalent inductance and capacitance as determined above can be found by substituting these values in the equations relating inductance and capacitance to reactance, or by using the various charts and calculators available. The frequency corresponding to the line length in degrees must be used, of course. In this example, if the frequency is 14 MHz the equivalent inductance and capacitance in the two cases are 16.4  $\mu\text{H}$  and 46.2 pF, respectively. Note that when the line length is  $45^\circ$  ( $0.125\lambda$ ), the reactance in either case is numerically equal to the characteristic impedance of the line. In using the Smith Chart it should be kept in mind that the electrical length of a line section depends on the frequency and velocity of propagation, as well as on the actual physical length.

At lengths of line that are exact multiples of  $1/4\lambda$ , such lines have the properties of resonant circuits. At lengths where the input reactance passes through zero at the left of the Smith Chart, the line acts as a series-resonant circuit. At lengths for which the reactances theoretically pass from “positive” to “negative” infinity at the right of the Smith Chart, the line simulates a parallel-resonant circuit.

### Designing Stub Matches with the Smith Chart

The design of stub matches is covered in detail in Chapter 26. Equations are presented there to calculate the electrical lengths of the main line and the stub, based on a purely resistive load and on the stub being the same type of line as the main line. The Smith Chart may also be used to determine these lengths, without the requirements that the load be purely resistive and that the line types be identical.

Fig 12 shows the stub matching arrangement in coaxial line. As an example, suppose that the load is an antenna, a close-spaced array fed with a 52- $\Omega$  line. Further suppose that the SWR has been measured as 3.1:1. From this information, a constant SWR circle may be drawn on the Smith Chart. Its radius is such that it intersects the right portion of the resistance axis at the SWR value, 3.1, as shown at point B in Fig 13.

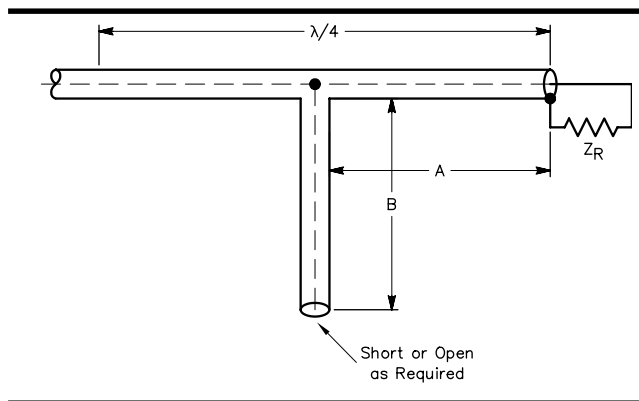


Fig 12—The method of stub matching a mismatched load on coaxial lines.

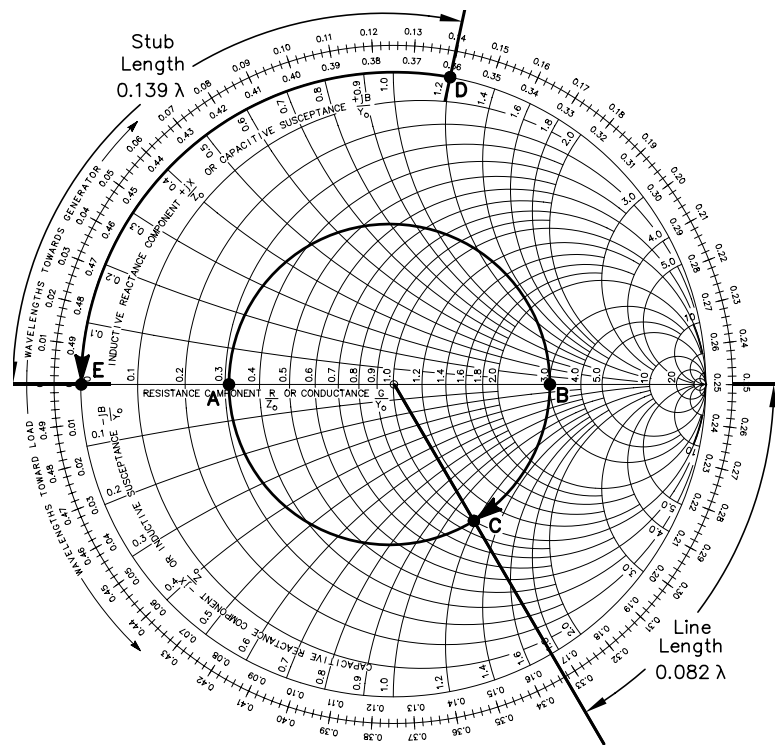


Fig 13—Smith Chart method of determining the dimensions for stub matching.

Since the stub of Fig 12 is connected in parallel with the transmission line, determining the design of the matching arrangement is simplified if Smith Chart values are dealt with as admittances, rather than impedances. (An admittance is simply the reciprocal of the associated impedance. Plotted on the Smith Chart, the two associated points are on the same SWR circle, but diametrically opposite each other.) Using admittances leaves less chance for errors in making calculations, by eliminating the need for making series-equivalent to parallel-equivalent circuit conversions and back, or else for using complicated equations for determining the resultant value of two complex impedances connected in parallel.

A complex impedance,  $Z$ , is equal to  $R + jX$ , as described in Chapter 24. The equivalent admittance,  $Y$ , is equal to  $G - jB$ , where  $G$  is the conductive component and  $B$  the susceptance. (Inductance is taken as negative susceptance, and capacitance as positive.) Conductance and susceptance values are plotted and handled on the Smith Chart in the same manner as resistance and reactance.

Assuming that the close-spaced array of our example has been resonated at the operating frequency, it will present a purely resistive termination for the load end of the 52- $\Omega$  line. From information in Chapter 24, it is known that the impedance of the antenna equals  $Z_0/\text{SWR} = 52/3.1 = 16.8 \Omega$ . (We can logically discard the possibility that the antenna impedance is  $\text{SWR} \times Z_0$ , or  $0.06 \Omega$ .) If this 16.8- $\Omega$  value were to be plotted as an impedance on the Smith Chart, it would first be normalized ( $16.8/52 = 0.32$ ) and then plotted as  $0.32 + j0$ . Although not necessary for the solution of this example, this value is plotted at point A in Fig 13. What is necessary is a plot of the admittance for the antenna as a load. This is the reciprocal of the impedance;  $1/16.8 \Omega$  equals 0.060 siemen. To plot this point it is first normalized by multiplying the conductance and susceptance values by the  $Z_0$  of the line. Thus,  $(0.060 + j0) \times 52 = 3.1 + j0$ . This admittance value is shown plotted at point B in Fig 13. It may be seen that points A and B are diametrically opposite each other on the chart. Actually, for the solution of this example, it wasn't necessary to compute the values for either point A or point B as in the above paragraph, for they were both determined from the known SWR value of 3.1. As may be seen in Fig 13, the points are located on the constant SWR circle which was already drawn, at the two places where it intersects the resistance axis. The plotted value for point A, 0.32, is simply the reciprocal of the value for point B, 3.1. However, an understanding of the relationship between impedance and admittance is easier to gain with simple examples such as this.

In stub matching, the stub is to be connected at a point in the line where the conductive component equals the  $Z_0$  of the line. Point B represents the admittance of the load, which is the antenna. Various admittances will be encountered along the line, when moving in a direction indicated by the TOWARD GENERATOR wavelengths scale, but all admittance plots must fall on the constant SWR circle. Moving clockwise around

the SWR circle from point B, it is seen that the line input conductance will be 1.0 (normalized  $Z_0$  of the line) at point C,  $0.082 \lambda$  toward the transmitter from the antenna. Thus, the stub should be connected at this location on the line.

The normalized admittance at point C, the point representing the location of the stub, is  $1 - j1.2$  siemens, having an inductive susceptance component. A capacitive susceptance having a normalized value of  $+j1.2$  siemens is required across the line at the point of stub connection, to cancel the inductance. This capacitance is to be obtained from the stub section itself; the problem now is to determine its type of termination (open or shorted), and how long the stub should be. This is done by first plotting the susceptance required for cancellation,  $0 + j1.2$ , on the chart (point D in Fig 13). This point represents the input admittance as seen looking into the stub. The "load" or termination for the stub section is found by moving in the TOWARD LOAD direction around the chart, and will appear at the closest point on the resistance/conductance axis, either at the left or the right of the chart. Moving counterclockwise from point D, this is located at E, at the left of the chart,  $0.139 \lambda$  away. From this we know the required stub length. The "load" at the far end of the stub, as represented on the Smith Chart, has a normalized admittance of  $0 + j0$  siemen, which is equivalent to an open circuit.

When the stub, having an input admittance of  $0 + j1.2$  siemens, is connected in parallel with the line at a point  $0.082 \lambda$  from the load, where the line input admittance is  $1.0 - j1.2$ , the resultant admittance is the sum of the individual admittances. The conductance components are added directly, as are the susceptance components. In this case,  $1.0 - j1.2 + j1.2 = 1.0 + j0$  siemen. Thus, the line from the point of stub connection to the transmitter will be terminated in a load which offers a perfect match. When determining the physical line lengths for stub matching, it is important to remember that the velocity factor for the type of line in use must be considered.

## MATCHING WITH LUMPED CONSTANTS

It was pointed out earlier that the purpose of a matching stub is to cancel the reactive component of line impedance at the point of connection. In other words, the stub is simply a reactance of the proper kind and value shunted across the line. It does not matter what physical shape this reactance takes. It can be a section of transmission line or a "lumped" inductance or capacitance, as desired. In the above example with the Smith Chart solution, a capacitive reactance was required. A capacitor having the same value of reactance can be used just as well. There are cases where, from an installation standpoint, it may be considerably more convenient to connect a capacitor in place of a stub. This is particularly true when open-wire feeders are used. If a variable capacitor is used, it becomes possible to adjust the capacitance to the exact value required.

The proper value of reactance may be determined from



Smith Chart information. In the previous example, the required susceptance, normalized, was  $+j1.2$  siemens. This is converted into actual siemens by dividing by the line  $Z_0$ ;  $1.2/52 = 0.023$  siemen, capacitance. The required capacitive reactance is the reciprocal of this latter value,  $1/0.023 = 43.5 \Omega$ . If the frequency is 14.2 MHz, for instance,  $43.5 \Omega$  corresponds to a capacitance of 258 pF. A 325-pF variable

capacitor connected across the line  $0.082 \lambda$  from the antenna terminals would provide ample adjustment range. The RMS voltage across the capacitor is

$$E = \sqrt{P \times Z_0}$$

For 500 W, for example,  $E =$  the square root of  $500 \times 52 = 161$  V. The peak voltage is 1.41 times the RMS value, or 227 V.

## The Series-Section Transformer

The series-section transformer is described in Chapter 26, and equations are given there for its design. The transformer can be designed graphically with the aid of a Smith Chart. This information is based on a *QST* article by Frank A. Regier, OD5CG. Using the Smith Chart to design a series-section match requires the use of the chart in its less familiar off-center mode. This mode is described in the next two paragraphs.

Fig 14 shows the Smith Chart used in its familiar centered mode, with all impedances normalized to that of the transmission line, in this case  $75 \Omega$ , and all constant SWR circles concentric with the normalized value  $r = 1$  at the chart center. An actual impedance is recovered by multiplying a chart reading by the normalizing impedance of  $75 \Omega$ . If the actual (unnormalized) impedances represented

by a constant SWR circle in Fig 14 are instead divided by a normalizing impedance of  $300 \Omega$ , a different picture results. A Smith Chart shows all possible impedances, and so a closed path such as a constant SWR circle in Fig 14 must again be represented by a closed path. In fact, it can be shown that the path remains a circle, but that the constant SWR circles are no longer concentric. Fig 15 shows the circles that result when the impedances along a mismatched  $75\text{-}\Omega$  line are normalized by dividing by  $300 \Omega$  instead of  $75$ . The constant SWR circles still surround the point corresponding to the characteristic impedance of the line ( $r = 0.25$ ) but are no longer concentric with it. Note that the normalized impedances read from corresponding points on Figs 14 and 15 are different but that the actual, unnormalized, impedances are exactly the same.

### An Example

Now turn to the example shown in Fig 16. A complex load of  $Z_L = 600 + j900 \Omega$  is to be fed with  $300\text{-}\Omega$  line, and a  $75\text{-}\Omega$  series section is to be used. These characteristic impedances agree with those used in Fig 15, and thus Fig 15 can be used to find the impedance variation along the  $75\text{-}\Omega$  series section. In particular, the constant SWR circle which passes through the Fig 15 chart center,  $\text{SWR} = 4$  in this case, passes through all the impedances (normalized to  $300 \Omega$ ) which the  $75\text{-}\Omega$  series section is able to match to the  $300\text{-}\Omega$  main line. The length  $\ell_1$  of  $300\text{-}\Omega$  line has the job of transforming the load impedance to some impedance on this matching circle.

Fig 17 shows the whole process more clearly, with all impedances normalized to  $300 \Omega$ . Here the normalized load impedance  $Z_L = 2 + j3$  is shown at R, and the matching circle appears centered on the resistance axis and passing through the points  $r = 1$  and  $r = n^2 = (75/300)^2 = 0.0625$ . A constant SWR circle is drawn from R to an intersection with the matching circle at Q or Q' and the corresponding length  $\ell_1$  (or  $\ell_1'$ ) can be read directly from the Smith Chart. The clockwise distance around the matching circle represents the length of the matching line, from either Q' to P or from Q to P. Because in this

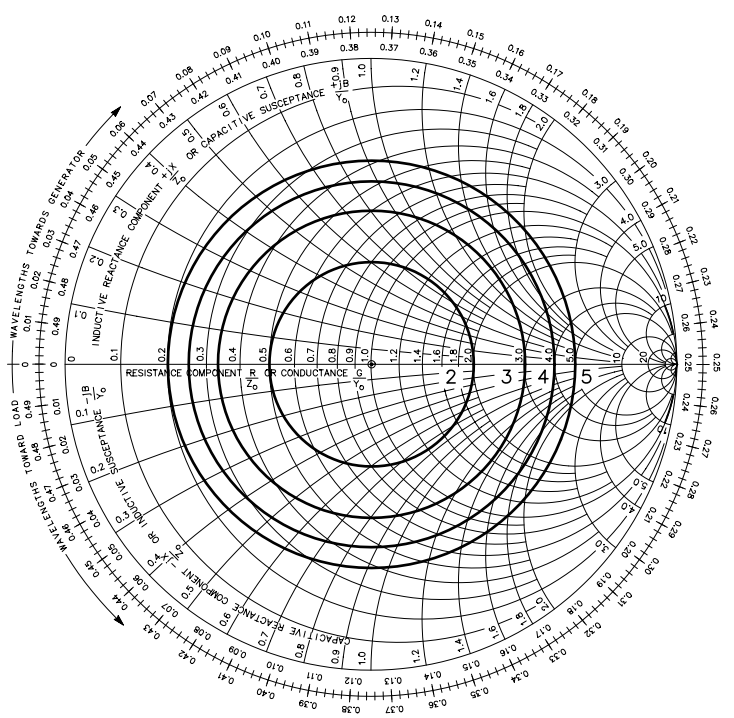


Fig 14—Constant SWR circles for  $\text{SWR} = 2, 3, 4$  and  $5$ , showing impedance variation along  $75\text{-}\Omega$  line, normalized to  $75 \Omega$ . The actual impedance is obtained by multiplying the chart reading by  $75 \Omega$ .

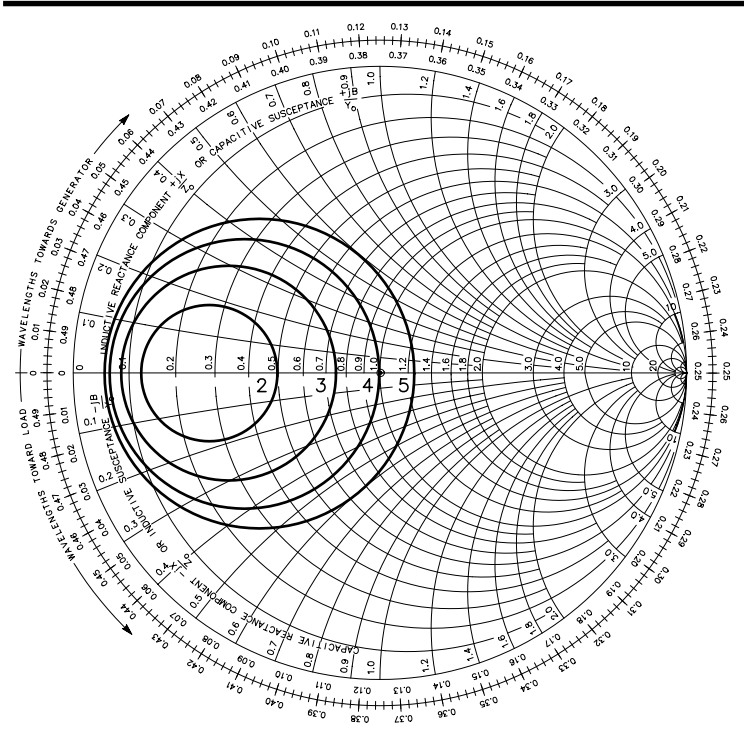


Fig 15—Paths of constant SWR for SWR = 2, 3, 4 and 5, showing impedance variation along 75- $\Omega$  line, normalized to 300  $\Omega$ . Normalized impedances differ from those in Fig 14, but actual impedances are obtained by multiplying chart readings by 300  $\Omega$  and are the same as those corresponding in Fig 14. Paths remain circles but are no longer concentric. One, the matching circle, SWR = 4 in this case, passes through the chart center and is thus the locus of all impedances which can be matched to a 300- $\Omega$  line.

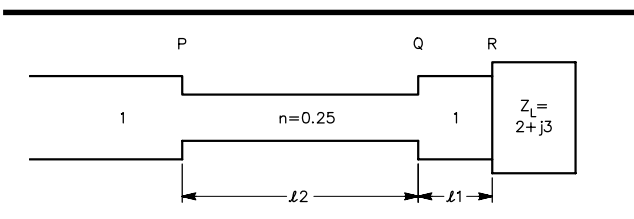


Fig 16—Example for solution by Smith Chart. All impedances are normalized to 300  $\Omega$ .

example the distance QP is the shorter of the two for the matching section, we choose the length  $\ell_1$  as shown. By using values from the TOWARD GENERATOR scale, this length is found as 0.045 – 0.213, and adding 0.5 to obtain a positive result yields a value of 0.332  $\lambda$ .

Although the impedance locus from Q to P is shown in Fig 17, the length  $\ell_2$  cannot be determined directly from this chart. This is because the matching circle is not concentric with the chart center, so the wavelength scales do not apply to this circle. This problem is overcome by forming Fig 18, which is the same as Fig 17 except that all normalized impedances have been divided by  $n = 0.25$ , resulting in a Smith Chart normalized to 75  $\Omega$  instead of 300. The matching circle and the chart center are now concentric, and the series-section length  $\ell_2$ , the distance between Q and P, can be taken directly from the chart. By again using the TOWARD GENERATOR scale, this length is found as 0.250 – 0.148 = 0.102  $\lambda$ .

In fact it is not necessary to construct the entire impedance locus shown in Fig 18. It is sufficient to plot  $Z_Q/n$  ( $Z_Q$  is read from Fig 17) and  $Z_P/n = 1/n$ , connect them by a circular arc centered on the chart center, and to determine the arc length  $\ell_2$  from the Smith Chart.

### Procedure Summary

The steps necessary to design a series-section transformer by means of the Smith Chart can now be listed:

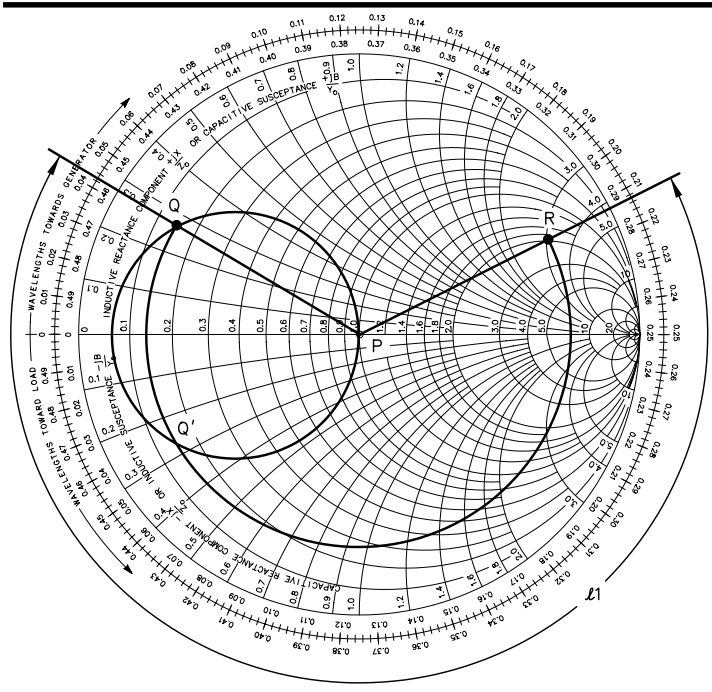
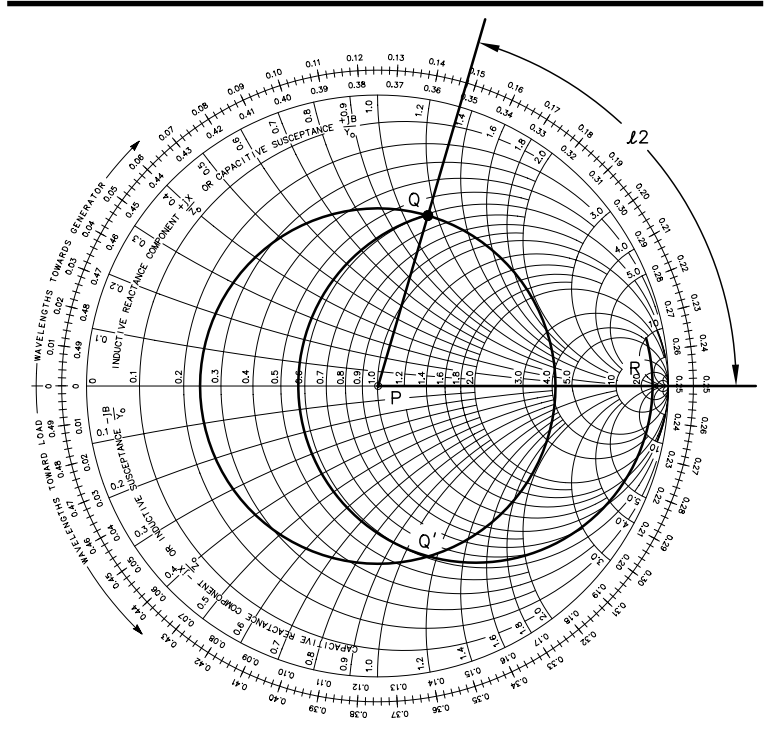


Fig 17—Smith Chart representation of the example shown in Fig 16. The impedance locus always takes a clockwise direction from the load to the generator. This path is first along the constant SWR circle from the load at R to an intersection with the matching circle at Q or Q', and then along the matching circle to the chart center at P. Length  $\ell_1$  can be determined directly from the chart, and in this example is 0.332  $\lambda$ .

- 1) Normalize all impedances by dividing by the characteristic impedance of the main line.
- 2) On a Smith Chart, plot the normalized load impedance  $Z_L$  at R and construct the matching circle so that its center is on the resistance axis and it passes through the points  $r = 1$  and  $r = n^2$ .
- 3) Construct a constant SWR circle centered on the chart center through point R. This circle should intersect the matching circle at two points. One of these points, normally the one resulting in the shorter clockwise distance along the matching circle to the chart center, is chosen as point Q, and the clockwise distance from R to Q is read from the chart and taken to be  $\ell_1$ .
- 4) Read the impedance  $Z_Q$  from the chart, calculate  $Z_Q/n$  and plot it as point Q on a second Smith Chart. Also plot  $r = 1/n$  as point P.
- 5) On this second chart construct a circular arc, centered on the chart center, clockwise from Q to P. The length of this arc, read from the chart, represents  $\ell_2$ . The design of the transformer is now complete, and the necessary physical line lengths may be determined.

The Smith Chart construction shows that two design solutions are usually possible, corresponding to the two intersections of the constant SWR circle (for the load) and the matching circle. These two values correspond to positive and negative values of the square-root radical in the equation for a mathematical solution of the problem. It may happen, however, that the load circle misses the matching circle completely, in which case no solution is possible. The cure is to enlarge the matching circle by choosing a series section whose impedance departs more from that of the main line.

A final possibility is that, rather than intersecting the matching circle, the load circle is tangent to it. There is then but one solution—that of the  $1/4\text{-}\lambda$  transformer.



**Fig 18—The same impedance locus as shown in Fig 17 except normalized to 75  $\Omega$  instead of 300. The matching circle is now concentric with the chart center, and  $\ell_2$  can be determined directly from the chart, 0.102  $\lambda$  in this case.**

## BIBLIOGRAPHY

Source material and more extended discussion of topics covered in this chapter can be found in the references given below and in the textbooks listed at the end of [Chapter 2](#).

- W. N. Caron, *Antenna Impedance Matching* (Newington: ARRL, 1989).
- C. MacKeand, "The Smith Chart in BASIC," *QST*, Nov 1984, pp 28-31.
- M. W. Maxwell, *Reflections—Transmission Lines and Antennas* (Newington: ARRL, 1990).
- F. A. Regier, "Series-Section Transmission-Line Impedance Matching," *QST*, Jul 1978, pp 14-16.
- P. H. Smith, *Electronic Applications of the Smith Chart*, reprint ed. (Malabar, FL: Krieger Pub Co, Inc, 1983).

# Appendix

This appendix contains a glossary of terms, a list of common abbreviations, length conversion information (feet and inches), metric equivalents and antenna-gain-reference data

## Glossary of Terms

This glossary provides a handy list of terms that are used frequently in Amateur Radio conversation and literature about antennas. With each item is a brief definition of the term. Most terms given here are discussed more thoroughly in the text of this book, and may be located by using the index.

- Actual ground*—The point within the earth's surface where effective ground conductivity exists. The depth for this point varies with frequency and the condition of the soil.
- Antenna*—An electrical conductor or array of conductors that radiates signal energy (transmitting) or collects signal energy (receiving).
- Antenna tuner*—See [Transmatch](#).
- Aperture, effective*—An area enclosing an antenna, on which it is convenient to make calculations of field strength and antenna gain. Sometimes referred to as the "capture area."
- Apex*—The feed-point region of a V type of antenna.
- Apex angle*—The included angle between the wires of a V, an inverted V dipole, and similar antennas, or the included angle between the two imaginary lines touching the element tips of a log periodic array.
- Balanced line*—A symmetrical two-conductor feed line that has uniform voltage and current distribution along its length.
- Balun*—A device for feeding a balanced load with an unbalanced line, or vice versa. May be a form of choke, or a transformer that provides a specific impedance transformation (including 1:1). Often used in antenna systems to interface a coaxial transmission line to the feed point of a balanced antenna, such as a dipole.
- Base loading*—A lumped reactance that is inserted at the base (ground end) of a vertical antenna to resonate the antenna.
- Bazooka*—A transmission-line balancer. It is a quarter-wave conductive sleeve (tubing or flexible shielding) placed at the feed point of a center-fed element and grounded to the shield braid of the coaxial feed line at the end of the sleeve farthest from the feed point. It permits the use of unbalanced feed line with balanced feed antennas.
- Beamwidth*—Related to directive antennas. The width, in degrees, of the major lobe between the two directions at which the relative radiated power is equal to one half its value at the peak of the lobe (half power = -3 dB).
- Beta match*—A form of hairpin match. The two conductors straddle the boom of the antenna being matched, and the closed end of the matching-section conductors are strapped to the boom.
- Bridge*—A circuit with two or more ports that is used in measurements of impedance, resistance or standing waves in an antenna system. When the bridge is adjusted for a balanced condition, the unknown factor can be determined by reading its value on a calibrated scale or meter.
- Capacitance hat*—A conductor of large surface area that is connected at the high-impedance end of an antenna to effectively increase the electrical length. It is sometimes mounted directly above a loading coil to reduce the required inductance for establishing resonance. It usually takes the form of a series of wheel spokes or a solid circular disc. Sometimes referred to as a "top hat."
- Capture area*—See aperture.
- Center fed*—Transmission-line connection at the electrical center of an antenna radiator.
- Center loading*—A scheme for inserting inductive reactance (coil) at or near the center of an antenna element for the purpose of lowering its resonant frequency. Used with elements that are less than  $\frac{1}{4}$  wavelength at the operating frequency.
- Coax*—See coaxial cable.
- Coaxial cable*—Any of the coaxial transmission lines that have the outer shield (solid or braided) on the same axis as the inner or center conductor. The insulating material can be air, helium or solid-dielectric compounds.
- Collinear array*—A linear array of radiating elements (usually dipoles) with their axes arranged in a straight line. Popular at VHF and above.
- Conductor*—A metal body such as tubing, rod or wire that permits current to travel continuously along its length.
- Counterpoise*—A wire or group of wires mounted close to ground, but insulated from ground, to form a low-impedance, high-capacitance path to ground. Used at MF and HF to provide an RF ground for an antenna. Also see ground plane.

- Current loop*—A point of current maxima (antipode) on an antenna.
- Current node*—A point of current minima on an antenna.
- Decibel*—A logarithmic power ratio, abbreviated dB. May also represent a voltage or current ratio if the voltages or currents are measured across (or through) identical impedances. Suffixes to the abbreviation indicate references: dBi, isotropic radiator; dBic, isotropic radiator circular; dBm, milliwatt; dBW, watt.
- Delta loop*—A full-wave loop shaped like a triangle or delta.
- Delta match*—Center-feed technique used with radiators that are not split at the center. The feed line is fanned near the radiator center and connected to the radiator symmetrically. The fanned area is delta shaped.
- Dielectrics*—Various insulating materials used in antenna systems, such as found in insulators and transmission lines.
- Dipole*—An antenna that is split at the exact center for connection to a feed line, usually a half wavelength long. Also called a “doublet.”
- Direct ray*—Transmitted signal energy that arrives at the receiving antenna directly rather than being reflected by any object or medium.
- Directivity*—The property of an antenna that concentrates the radiated energy to form one or more major lobes.
- Director*—A conductor placed in front of a driven element to cause directivity. Frequently used singly or in multiples with Yagi or cubical-quad beam antennas.
- Doublet*—See dipole.
- Driven array*—An array of antenna elements which are all driven or excited by means of a transmission line, usually to achieve directivity.
- Driven element*—A radiator element of an antenna system to which the transmission line is connected.
- Dummy load*—Synonymous with dummy antenna. A nonradiating substitute for an antenna.
- E layer*—The ionospheric layer nearest earth from which radio signals can be reflected to a distant point, generally a maximum of 2000 km (1250 ml).
- E plane*—Related to a linearly polarized antenna, the plane containing the electric field vector of the antenna and its direction of maximum radiation. For terrestrial antenna systems, the direction of the E plane is also taken as the polarization of the antenna. The E plane is at right angles to the H plane.
- Efficiency*—The ratio of useful output power to input power, determined in antenna systems by losses in the system, including in nearby objects.
- EIRP*—Effective isotropic radiated power. The power radiated by an antenna in its favored direction, taking the gain of the antenna into account as referenced to isotropic.
- Elements*—The conductive parts of an antenna system that determine the antenna characteristics. For example, the reflector, driven element and directors of a Yagi antenna.
- End effect*—A condition caused by capacitance at the ends of an antenna element. Insulators and related support wires contribute to this capacitance and lower the resonant frequency of the antenna. The effect increases with conductor diameter and must be considered when cutting an antenna element to length.
- End fed*—An end-fed antenna is one to which power is applied at one end, rather than at some point between the ends.
- F layer*—The ionospheric layer that lies above the E layer. Radio waves can be refracted from it to provide communications distances of several thousand miles by means of single- or double-hop skip.
- Feed line*—See feeders.
- Feeders*—Transmission lines of assorted types that are used to route RF power from a transmitter to an antenna, or from an antenna to a receiver.
- Field strength*—The intensity of a radio wave as measured at a point some distance from the antenna. This measurement is usually made in microvolts per meter.
- Front to back*—The ratio of the radiated power off the front and back of a directive antenna. For example, a dipole would have a ratio of 1, which is equivalent to 0 dB.
- Front to side*—The ratio of radiated power between the major lobe and that 90° off the front of a directive antenna.
- Gain*—The increase in effective radiated power in the desired direction of the major lobe.
- Gamma match*—A matching system used with driven antenna elements to effect a match between the transmission line and the feed point of the antenna. It consists of a series capacitor and an arm that is mounted close to the driven element and in parallel with it near the feed point.
- Ground plane*—A system of conductors placed beneath an elevated antenna to serve as an earth ground. Also see counterpoise.
- Ground screen*—A wire mesh counterpoise.
- Ground wave*—Radio waves that travel along the earth’s surface.
- H plane*—Related to a linearly polarized antenna. The plane containing the magnetic field vector of an antenna and its direction of maximum radiation. The H plane is at right angles to the E plane.
- HAAT*—Height above average terrain. A term used mainly in connection with repeater antennas in determining coverage area.
- Hairpin match*—A U-shaped conductor that is connected to the two inner ends of a split dipole for the purpose of creating an impedance match to a balanced feeder.
- Harmonic antenna*—An antenna that will operate on its fundamental frequency and the harmonics of the fundamental frequency for which it is designed. An end-fed half-wave antenna is one example.

- Helical*—A helically wound antenna, one that consists of a spiral conductor. If it has a very large winding length to diameter ratio it provides broadside radiation. If the length-to-diameter ratio is small, it will operate in the axial mode and radiate off the end opposite the feed point. The polarization will be circular for the axial mode, with left or right circularity, depending on whether the helix is wound clockwise or counterclockwise.
- Helical hairpin*—“Hairpin” match with a lumped inductor, rather than parallel-conductor line.
- Image antenna*—The imaginary counterpart of an actual antenna. It is assumed for mathematical purposes to be located below the earth’s surface beneath the antenna, and is considered symmetrical with the antenna above ground.
- Impedance*—The ohmic value of an antenna feed point, matching section or transmission line. An impedance may contain a reactance as well as a resistance component.
- Inverted V*—A misnomer, as the antenna being referenced does not have the characteristics of a V antenna. See inverted-V dipole.
- Inverted-V dipole*—A half-wavelength dipole erected in the form of an upside-down V, with the feed point at the apex. Its radiation pattern is similar to that of a horizontal dipole.
- Isotropic*—An imaginary or hypothetical point-source antenna that radiates equal power in all directions. It is used as a reference for the directive characteristics of actual antennas.
- Lambda*—Greek symbol ( $\lambda$ ) used to represent a wavelength with reference to electrical dimensions in antenna work.
- Line loss*—The power lost in a transmission line, usually expressed in decibels.
- Line of sight*—Transmission path of a wave that travels directly from the transmitting antenna to the receiving antenna.
- Litz wire*—Stranded wire with individual strands insulated; small wire provides a large surface area for current flow, so losses are reduced for the wire size.
- Load*—The electrical entity to which power is delivered. The antenna system is a load for the transmitter.
- Loading*—The process of transferring power from its source to a load. The effect a load has on a power source.
- Lobe*—A defined field of energy that radiates from a directive antenna.
- Log periodic antenna*—A broadband directive antenna that has a structural format causing its impedance and radiation characteristics to repeat periodically as the logarithm of frequency.
- Long wire*—A wire antenna that is one wavelength or greater in electrical length. When two or more wavelengths long it provides gain and a multilobe radiation pattern. When terminated at one end it becomes essentially unidirectional off that end.
- Marconi antenna*—A shunt-fed monopole operated against ground or a radial system. In modern jargon, the term refers loosely to any type of vertical antenna.
- Matching*—The process of effecting an impedance match between two electrical circuits of unlike impedance. One example is matching a transmission line to the feed point of an antenna. Maximum power transfer to the load (antenna system) will occur when a matched condition exists.
- Monopole*—Literally, one pole, such as a vertical radiator operated against the earth or a counterpoise.
- Nichrome wire*—An alloy of nickel and chromium; not a good conductor; resistance wire. Used in the heating elements of electrical appliances; also as conductors in transmission lines or circuits where attenuation is desired.
- Null*—A condition during which an electrical unit is at a minimum. The null in an antenna radiation pattern is that point in the 360-degree pattern where a minima in field intensity is observed. An impedance bridge is said to be “pulled” when it has been brought into balance, with a null in the current flowing through the bridge arm.
- Octave*—A musical term. As related to RF, frequencies having a 2:1 harmonic relationship.
- Open-wire line*—A type of transmission line that resembles a ladder, sometimes called “ladder line.” Consists of parallel, symmetrical wires with insulating spacers at regular intervals to maintain the line spacing. The dielectric is principally air, making it a low-loss type of line.
- Parabolic reflector*—An antenna reflector that is a portion of a parabolic revolution or curve. Used mainly at UHF and higher to obtain high gain and a relatively narrow beamwidth when excited by one of a variety of driven elements placed in the plane of and perpendicular to the axis of the parabola.
- Parasitic array*—A directive antenna that has a driven element and at least one independent director or reflector, or a combination of both. The directors and reflectors are not connected to the feed line. Except for VHF and UHF arrays with long booms (electrically), more than one reflector is seldom used. A Yagi antenna is one example of a parasitic array.
- Phasing lines*—Sections of transmission line that are used to ensure the correct phase relationship between the elements of a driven array, or between bays of an array of antennas. Also used to effect impedance transformations while maintaining the desired phase.
- Polarization*—The sense of the wave radiated by an antenna. This can be horizontal, vertical, elliptical or circular (left or right hand circularity), depending on the design and application. (See H plane.)
- Q section*—Term used in reference to transmission-line matching transformers and phasing lines.

*Quad*—A parasitic array using rectangular or diamond shaped full-wave wire loop elements. Often called the “cubical quad.” Another version uses delta-shaped elements, and is called a delta loop beam.

*Radiation pattern*—The radiation characteristics of an antenna as a function of space coordinates. Normally, the pattern is measured in the far-field region and is represented graphically.

*Radiation resistance*—The ratio of the power radiated by an antenna to the square of the RMS antenna current, referred to a specific point and assuming no losses. The effective resistance at the antenna feed point.

*Radiator*—A discrete conductor that radiates RF energy in an antenna system.

*Random wire*—A random length of wire used as an antenna and fed at one end by means of a Transmatch. Seldom operates as a resonant antenna unless the length happens to be correct.

*Reflected ray*—A radio wave that is reflected from the earth, ionosphere or a man-made medium, such as a passive reflector.

*Reflector*—A parasitic antenna element or a metal assembly that is located behind the driven element to enhance forward directivity. Hillsides and large man-made structures such as buildings and towers may act as reflectors.

*Refraction*—Process by which a radio wave is bent and returned to earth from an ionospheric layer or other medium after striking the medium.

*Resonator*—In antenna terminology, a loading assembly consisting of a coil and a short radiator section. Used to lower the resonant frequency of an antenna, usually a vertical or a mobile whip.

*Rhombic*—A rhomboid or diamond-shaped antenna consisting of sides (legs) that are each one or more wavelengths long. The antenna is usually erected parallel to the ground. A rhombic antenna is bidirectional unless terminated by a resistance, which makes it unidirectional. The greater the electrical leg length, the greater the gain, assuming the tilt angle is optimized.

*Shunt feed*—A method of feeding an antenna driven element with a parallel conductor mounted adjacent to a low-impedance point on the radiator. Frequently used with grounded quarter-wave vertical antennas to provide an impedance match to the feeder. Series feed is used when the base of the vertical is insulated from ground.

*Stacking*—The process of placing similar directive antennas atop or beside one another, forming a “stacked array.” Stacking provides more gain or directivity than a single antenna.

*Stub*—A section of transmission line used to tune an antenna element to resonance or to aid in obtaining an impedance match.

*SWR*—Standing-wave ratio on a transmission line in an antenna system. More correctly, VSWR, or voltage standing-wave ratio. The ratio of the forward to reflected voltage on the line, and not a power ratio. A VSWR of 1:1 occurs when all parts of the antenna system are matched correctly to one another.

*T match*—Method for matching a transmission-line to an unbroken driven element. Attached at the electrical center of the driven element in a T-shaped manner. In effect it is a double gamma match.

*Tilt angle*—Half the angle included between the wires at the sides of a rhombic antenna.

*Top hat*—See [capacitance hat](#).

*Top loading*—Addition of a reactance (usually a capacitance hat) at the end of an antenna element opposite the feed point to increase the electrical length of the radiator.

*Transmatch*—An antenna tuner. A device containing variable reactances (and perhaps a balun). It is connected between the transmitter and the feed point of an antenna system, and adjusted to “tune” or resonate the system to the operating frequency.

*Trap*—Parallel L-C network inserted in an antenna element to provide multiband operation with a single conductor.

*Unipole*—See [monopole](#).

*Velocity factor*—The ratio of the velocity of radio wave propagation in a dielectric medium to that in free space. When cutting a transmission line to a specific electrical length, the velocity factor of the particular line must be taken into account.

*VSWR*—Voltage standing-wave ratio. See *SWR*.

*Wave*—A disturbance or variation that is a function of time or space, or both, transferring energy progressively from point to point. A radio wave, for example.

*Wave angle*—The angle above the horizon of a radio wave as it is launched from or received by an antenna.

*Wave front*—A surface that is a locus of all the points having the same phase at a given instant in time.

*Yagi*—A directive, gain type of antenna that utilizes a number of parasitic directors and a reflector. Named after one of the two Japanese inventors (Yagi and Uda).

*Zepp antenna*—A half-wave wire antenna that operates on its fundamental and harmonics. It is fed at one end by means of open-wire feeders. The name evolved from its popularity as an antenna on Zeppelins. In modern jargon the term refers loosely to any horizontal antenna.

# Abbreviations

Abbreviations and acronyms that are commonly used throughout this book are defined in the list below. Periods are not part of an abbreviation unless the abbreviation otherwise forms a common English word. When appropriate, abbreviations as shown are used in either singular or plural construction.

## **-A-**

A—ampere  
ac—alternating current  
AF—audio frequency  
AFSK—audio frequency-shift keying  
AGC—automatic gain control  
AM—amplitude modulation  
ANT—antenna  
ARRL—American Radio Relay League  
ATV—amateur television  
AWG—American wire gauge  
az-el—azimuth-elevation

## **-B-**

balun—balanced to unbalanced  
BC—broadcast  
BCI—broadcast interference  
BW—bandwidth

## **-C-**

ccw—counterclockwise  
cm—centimeter  
coax—coaxial cable  
CT—center tap  
cw—clockwise  
CW—continuous wave

## **-D-**

D—diode  
dB—decibel  
dBd—decibels referenced to a dipole  
dBi—decibels referenced to isotropic  
dBic—decibels referenced to isotropic, circular  
dBm—decibels referenced to one milliwatt  
dBW—decibels referenced to one watt  
dc—direct current  
deg—degree  
DF—direction finding  
dia—diameter  
DPDT—double pole, double throw  
DPST—double pole, single throw  
DVM—digital voltmeter  
DX—long distance communication

## **-E-**

E—ionospheric layer, electric field  
ed.—edition  
Ed.—editor  
EIRP—effective isotropic radiated power  
ELF—extremely low frequency  
EMC—electromagnetic compatibility  
EME—earth-moon-earth

EMF—electromotive force  
ERP—effective radiated power  
E<sub>S</sub>—ionospheric layer (sporadic E)

## **-F-**

f—frequency  
F—ionospheric layer, farad  
F/B—front to back (ratio)  
FM—frequency modulation  
FOT—frequency of optimum transmission  
ft—foot or feet (unit of length)  
F<sub>1</sub>—ionospheric layer  
F<sub>2</sub>—ionospheric layer

## **-G-**

GDO—grid- or gate-dip oscillator  
GHz—gigahertz  
GND—ground

## **-H-**

H—magnetic field, henry  
HAAT—height above average terrain  
HF—high frequency (3-30 MHz)  
Hz—hertz (unit of frequency)

## **-I-**

I—current  
ID—inside diameter  
IEEE—Institute of Electrical and Electronic Engineers  
in.—inch  
IRE—Institute of Radio Engineers (now IEEE)

## **-J-**

*j*—vector notation

## **-K-**

kHz—kilohertz  
km—kilometer  
kW—kilowatt  
k $\Omega$ —kilohm

## **-L-**

L—inductance  
lb—pound (unit of mass)  
LF—low frequency (30-300 kHz)  
LHCP—left-hand circular polarization  
ln—natural logarithm  
log—common logarithm  
LP—log periodic  
LPDA—log periodic dipole array  
LPVA—log periodic V array  
LUF—lowest usable frequency



**-M-**

m—meter (unit of length)  
 m/s—meters per second  
 mA—milliampere  
 max—maximum  
 MF—medium frequency (0.3-3 MHz)  
 mH—millihenry  
 MHz—megahertz  
 mi—mile  
 min—minute  
 mm—millimeter  
 ms—millisecond  
 mS—millisiemen  
 MS—meteor scatter  
 MUF—maximum usable frequency  
 mW—milliwatt  
 MW—megohm

**-N-**

NC—no connection, normally closed  
 NiCd—nickel cadmium  
 NIST—National Institute of Standards and Technology  
 NO—normally open  
 no.—number

**-O-**

OD—outside diameter

**-P-**

p—page (bibliography reference)  
 P-P—peak to peak  
 PC—printed circuit  
 PEP—peak envelope power  
 pF—picofarad  
 pot—potentiometer  
 pp—pages (bibliography reference)  
 Proc—Proceedings

**-Q-**

Q—figure of merit

**-R-**

R—resistance, resistor  
 RF—radio frequency  
 RFC—radio frequency choke  
 RFI—radio frequency interference  
 RHCP—right-hand circular polarization  
 RLC—resistance-inductance-capacitance  
 r/min—revolutions per minute  
 RMS—root mean square  
 r/s—revolutions per second  
 RSGB—Radio Society of Great Britain  
 RX—receiver

**-S-**

s—second  
 S—siemen

S/NR—signal-to-noise ratio  
 SASE—self-addressed stamped envelope  
 SINAD—signal-to-noise and distortion  
 SPDT—single pole, double throw  
 SPST—single pole, single throw  
 SWR—standing wave ratio  
 sync—synchronous

**-T-**

tpi—turns per inch  
 TR—transmit-receive  
 TVI—television interference  
 TX—transmitter

**-U-**

UHF—ultra-high frequency (300-3000 MHz)  
 US—United States  
 UTC—Universal Time, Coordinated

**-V-**

V—volt  
 VF—velocity factor  
 VHF—very-high frequency (30-300 MHz)  
 VLF—very-low frequency (3-30 kHz)  
 Vol—volume (bibliography reference)  
 VOM—volt-ohm meter  
 VSWR—voltage standing-wave ratio  
 VTVM—vacuum-tube voltmeter

**-W-**

W—watt  
 WPM—words per minute  
 WRC—World Radio Conference  
 WVDC—working voltage, direct current

**-X-**

X—reactance  
 XCVR—transceiver  
 XFMR—transformer  
 XMTR—transmitter

**-Z-**

Z—impedance

**-Other symbols and Greek letters-**

°—degrees  
 $\lambda$ —wavelength  
 $\lambda/\text{dia}$ —wavelength to diameter (ratio)  
 $\mu$ —permeability  
 $\mu\text{F}$ —microfarad  
 $\mu\text{H}$ —microhenry  
 $\mu\text{V}$ —microvolt  
 $\Omega$ —ohm  
 $\phi$ —angles  
 $\pi$ —3.14159  
 $\theta$ —angles

# Length Conversions

Throughout this book, equations may be found for determining the design length and spacing of antenna elements. For convenience, the equations are written to yield a result in feet. (The answer may be converted to meters simply by multiplying the result by 0.3048.) If the result in feet is not an integral number, however, it is necessary to make a conversion from a decimal fraction of a foot to inches and fractions before the physical distance can be determined with a conventional tape measure. Table 1 may be used for this conversion, showing inches and fractions for increments of 0.01 foot. The table deals with only the fractional portion of a foot. The integral number of feet remains the same.

For example, say a calculation yields a result of 11.63 feet, and we wish to convert this to a length we can find on a tape measure. For the moment, consider only the fractional part of the number, 0.63 foot. In Table 1 locate the line with "0.6" appearing in the left column. (This is the 7th line down in the body of the table.) Then while staying on that line, move over to the column headed "0.03." Note here that the sum of the column and line heads, 0.6 + 0.03, equals the value of 0.63 that we want to convert. In the body of the table for this column and line we read the equivalent fraction for 0.63 foot,  $7\frac{9}{16}$  inches. To that value, add the number of whole feet from the value being converted, 11 in this case. The total length equivalent of 11.63 feet is thus 11 feet  $7\frac{9}{16}$  inches.

Similarly, Table 2 may be used to make the conversion from inches and fractions to decimal fractions of a foot. This table is convenient for using measured distances in

equations. For example, say we wish to convert a length of 19 feet  $7\frac{3}{4}$  inches to a decimal fraction. Considering only the fractional part of this value,  $7\frac{3}{4}$  inches, locate the decimal value on the line identified as "7-" and in the column headed " $\frac{3}{4}$ ," where we read 0.646. This decimal value is equivalent to  $7 + \frac{3}{4} = 7\frac{3}{4}$  inches. To this value add the whole number of feet from the value being converted for the final result, 19 in this case. In this way, 19 feet  $7\frac{3}{4}$  inches converts to  $19 + 0.646 = 19.646$  feet.

**Table 2**  
Conversion, Inches and Fractions to Decimal Feet

	Fractional Increments							
	0	$\frac{1}{8}$	$\frac{1}{4}$	$\frac{3}{8}$	$\frac{1}{2}$	$\frac{5}{8}$	$\frac{3}{4}$	$\frac{7}{8}$
0-	0.000	0.010	0.021	0.031	0.042	0.052	0.063	0.073
1-	0.083	0.094	0.104	0.115	0.125	0.135	0.146	0.156
2-	0.167	0.177	0.188	0.198	0.208	0.219	0.229	0.240
3-	0.250	0.260	0.271	0.281	0.292	0.302	0.313	0.323
4-	0.333	0.344	0.354	0.365	0.375	0.385	0.396	0.406
5-	0.417	0.427	0.438	0.448	0.458	0.469	0.479	0.490
6-	0.500	0.510	0.521	0.531	0.542	0.552	0.563	0.573
7-	0.583	0.594	0.604	0.615	0.625	0.635	0.646	0.656
8-	0.667	0.677	0.688	0.698	0.708	0.719	0.729	0.740
9-	0.750	0.760	0.771	0.781	0.792	0.802	0.813	0.823
10-	0.833	0.844	0.854	0.865	0.875	0.885	0.896	0.906
11-	0.917	0.927	0.938	0.948	0.958	0.969	0.979	0.990

**Table 1**  
Conversion, Decimal Feet to Inches (Nearest 16th)

	Decimal Increments									
	0.00	0.01	0.02	0.03	0.04	0.05	0.06	0.07	0.08	0.09
0.0	0-0	$0\frac{1}{8}$	$0\frac{1}{4}$	$0\frac{3}{8}$	$0\frac{1}{2}$	$0\frac{5}{8}$	$0\frac{3}{4}$	$0\frac{13}{16}$	$0\frac{15}{16}$	$1\frac{1}{16}$
0.1	$1\frac{3}{16}$	$1\frac{5}{16}$	$1\frac{7}{16}$	$1\frac{9}{16}$	$1\frac{11}{16}$	$1\frac{13}{16}$	$1\frac{15}{16}$	$2\frac{1}{16}$	$2\frac{3}{16}$	$2\frac{1}{4}$
0.2	$2\frac{3}{8}$	$2\frac{1}{2}$	$2\frac{5}{8}$	$2\frac{3}{4}$	$2\frac{7}{8}$	3-0	$3\frac{1}{8}$	$3\frac{1}{4}$	$3\frac{3}{8}$	$3\frac{1}{2}$
0.3	$3\frac{5}{8}$	$3\frac{3}{4}$	$3\frac{13}{16}$	$3\frac{15}{16}$	$4\frac{1}{16}$	$4\frac{3}{16}$	$4\frac{5}{16}$	$4\frac{7}{16}$	$4\frac{9}{16}$	$4\frac{11}{16}$
0.4	$4\frac{13}{16}$	$4\frac{15}{16}$	$5\frac{1}{16}$	$5\frac{3}{16}$	$5\frac{1}{4}$	$5\frac{3}{8}$	$5\frac{1}{2}$	$5\frac{5}{8}$	$5\frac{3}{4}$	$5\frac{7}{8}$
0.5	6-0	$6\frac{1}{8}$	$6\frac{1}{4}$	$6\frac{3}{8}$	$6\frac{1}{2}$	$6\frac{5}{8}$	$6\frac{3}{4}$	$6\frac{13}{16}$	$6\frac{15}{16}$	$7\frac{1}{16}$
0.6	$7\frac{3}{16}$	$7\frac{5}{16}$	$7\frac{7}{16}$	$7\frac{9}{16}$	$7\frac{11}{16}$	$7\frac{13}{16}$	$7\frac{15}{16}$	$8\frac{1}{16}$	$8\frac{3}{16}$	$8\frac{1}{4}$
0.7	$8\frac{3}{8}$	$8\frac{1}{2}$	$8\frac{5}{8}$	$8\frac{3}{4}$	$8\frac{7}{8}$	9-0	$9\frac{1}{8}$	$9\frac{1}{4}$	$9\frac{3}{8}$	$9\frac{1}{2}$
0.8	$9\frac{5}{8}$	$9\frac{3}{4}$	$9\frac{13}{16}$	$9\frac{15}{16}$	$10\frac{1}{16}$	$10\frac{3}{16}$	$10\frac{5}{16}$	$10\frac{7}{16}$	$10\frac{9}{16}$	$10\frac{11}{16}$
0.9	$10\frac{13}{16}$	$10\frac{15}{16}$	$11\frac{1}{16}$	$11\frac{3}{16}$	$11\frac{1}{4}$	$11\frac{3}{8}$	$11\frac{1}{2}$	$11\frac{5}{8}$	$11\frac{3}{4}$	$11\frac{7}{8}$

## Metric Equivalents

Throughout this book, distances and dimensions are usually expressed in English units—the mile, the foot, and the inch. Conversions to metric units may be made by using the following equations:

$$\text{km} = \text{mi} \times 1.609$$

$$\text{m} = \text{ft} (') \times 0.3048$$

$$\text{mm} = \text{in.} (") \times 25.4$$

An inch is  $1/12$  of a foot. Tables in the previous section provide information for accurately converting inches and fractions to decimal feet, and vice versa, without the need for a calculator.

## Gain Reference

Throughout this book, gain is referenced to an isotropic radiator (dBi) or to an isotropic radiator with circular polarization (dBic).

# SAVE BIG ON ANTENNAS, TOWERS & CABLE

## TELESCOPING ALUMINUM TUBING

<b>DRAWN 6063-T832</b>	1.250"	Call
.375	1.375"	Call
.500"	1.500"	Call
.625"	1.625"	Call
.750"	1.750"	Call
.875"	1.875"	Call
1.000"	2.000"	Call
1.125"	2.125"	Call

In 6' or 12' lengths, 6' lengths ship UPS. Call for 3/16" & 1/4" rod, bar stock, and extruded tubing.

## CUSHCRAFT ANTENNAS

X7/X9	Call
XM240	Call
R6000/R8	Call
A50-3S/5S/6S	Call
AR2/ARX2B	Call
AR270/AR270B	Call
ARX270U/ARX270N	Call
13B2/17B2/26B2	Call
719B/729B	Call
A270-6S/A270-10S	Call

Please call for more Cushcraft items

## FORCE 12-MULTIBAND

C3	10/12/15/17/20m, 7 el	Call
C3E	10/12/15/17/20m, 8 el	Call
C3S	10/12/15/17/20m, 6 el	Call
C3SS	10/12/15/17/20m, 6 el	Call
C4	10/12/15/17/20/40m, 8 el	Call
C4S	10/12/15/17/20/40m, 7 el	Call
C4SXL	10/12/15/17/20/40m, 8 el	Call
C4XL	10/12/15/17/20/40m, 9 el	Call
C19XR	10/15/20m, 11 el	Call
C31XR	10/15/20m, 14 el	Call

Please call for more Force 12 items

## TRYLON "TITAN" TOWERS

<b>SELF-SUPPORTING STEEL TOWERS</b>		
T200-64	64', 15 square feet	Call
T200-72	72', 15 square feet	Call
T200-80	80', 15 square feet	Call
T200-88	88', 15 square feet	Call
T200-96	96', 15 square feet	Call
T300-88	88', 22 square feet	Call
T400-80	80', 34 square feet	Call
T500-72	72', 45 square feet	Call
T600-64	64', 60 square feet	Call

Many more Trylon towers in stock!

## BENCHER / BUTTERNUT

Skyhawk, Triband Beam	Call
HF2V, 2 Band Vertical	Call
HF5B, 5 Band Minibeam	Call
HF6VX, 6 Band Vertical	Call
HF9VX, 9 Band Vertical	Call
A1712, 12/17m Kit	Call
CPK, Counterpoise Kit	Call
RMKII, Roof Mount Kit	Call
STR1I, Roof Radial Kit	Call
TBR160S, 160m Kit	Call

More Bencher/Butternut-call

## M2 VHF/UHF ANTENNAS

<b>144-148 MHz</b>	
2M4/2M7/2M9	Call
2M12/2M5WL	Call
2M5-440XP, 2m/70cm	Call
<b>420-450 MHz</b>	
420-470-5W/420-450-11	Call
432-9WL/432-13WL	Call
440-18/440-21ATV	Call
<b>Satellite Antennas</b>	
2MCP14/2MCP22	Call
436CP30/436CP42UG	Call

## ROHN TOWER

25G/45G/55G	Call
AS25G/AS455G	Call
GA25GD/45/55	Call
GAR30/GAS604	Call
SB25G/45/55	Call
TB3/TB4	Call
HBX32/HBX40	Call
HBX48/HBX56	Call
HDBX40/HDBX48	Call
BXB5/6/7/8	Call

Please call for more Rohn prices

## US TOWER

MA40/MA550	Call
MA770/MA850	Call
TMM433SS/HD	Call
TMM541SS	Call
TX438/TX455	Call
TX472/TX489	Call
HDX538/HDX555	Call
HDX572MDPL	Call

Please call for help selecting a US Tower for your needs. Shipped factory direct to save you money!

## COMET ANTENNAS

GP15, 6m/2m/70cm Vertical	Call
GP6, 2m/70cm Vertical	Call
GP9, 2m/70cm Vertical	Call
B10NMO, 2m/70cm Mobile	Call
B20NMO, 2m/70cm Mobile	Call
SBB2NMO, 2m/70cm Mobile	Call
SBB5NMO, 2m/70cm Mobile	Call
SBB7NMO, 2m/70cm Mobile	Call
Z750, 2m/70cm Mobile	Call
Z780, 2m/70cm Mobile	Call

Much more Comet in stock-call

## M2 ANTENNAS

<b>50-54 MHz</b>	
6M5X/6M7JHV	Call
6M2WLC/6M2.5WLC	Call
<b>10/12/15/17/20m HF</b>	
10M4DX, 4 Element 10m	Call
12M4DX, 4 Element 12m	Call
15M4DX, 4 Element 15m	Call
17M3DX, 3 Element 17m	Call
20M4DX, 4 Element 20m	Call

More M2 models in stock-please call

## GLEN MARTIN ENGINEERING

<b>Hazer Elevators for 25G</b>	
H2, Aluminum Hazer, 12 sq ft	Call
H3, Aluminum Hazer, 8 sq ft	Call
H4, HD Steel Hazer, 16 sq ft	Call
<b>Aluminum Roof Towers</b>	
RT424, 4 Foot, 6 sq ft	Call
RT832, 8 Foot, 8 sq ft	Call
RT936, 9 Foot, 18 sq ft	Call
RT1832, 17 Foot, 12 sq ft	Call

Please call for Glen Martin info

## UNIVERSAL ALUMINUM TOWERS

4-40'/50'/60'	Call
7-50'/60'/70'	Call
9-40'/50'/60'	Call
12-30'/40'	Call
15-40'/50'	Call
23-30'/40'	Call
35-30'/40'	Call

Bold in part number shows wind-load capacity. Please call for more Universal models. All are shipped factory direct to save you money!

## DIAMOND ANTENNAS

D130J/DPGH62	Call
F22A/F23A	Call
NR72BNMO/NR73BNMO	Call
NR770HBNMO/NR770RA	Call
X200A/X300A	Call
X500HNA/700HNA	Call
X510MA/510NA	Call
X50A/V2000A	Call
CR627B/SG2000HD	Call
SG7500NMO/SG7900A	Call

More Diamond antennas in stock

## MFJ ANTENNAS

259B Antenna Analyzer	Call
1798, 80-2m Vertical	Call
1796, 40/20/15/10/6/2m Vert.	Call
1793, 80/40/20m Vertical	Call
1792, 80/40m Vertical	Call
1788, 40-15m Loop	Call
1786, 30-10m Loop	Call
1780, 14-30 MHz Loop	Call
1768, 2m/70cm Beam	Call
1762, 3 Element 6m Beam	Call

Big MFJ inventory-please call

## COAX CABLE

RG-213/U, (#8267 Equiv.)	Call
RG-8X, Mini RG-8 Foam	Call
RG-213/U Jumpers	Call
RG-8X Jumpers	Call

Please call for more coax/connectors

## TIMES MICROWAVE LMR® COAX

LMR-400	Call
LMR-400 Ultraflex	Call
LMR-600	Call
LMR600 Ultraflex	Call

## TOWER HARDWARE

3/8"EE / EJ Turnbuckle	Call
1/2"x9"EE / EJ Turnbuckle	Call
1/2"x12"EE / EJ Turnbuckle	Call
3/16" / 1/4" Preformed Grips	Call

Please call for more hardware items

## HIGH CARBON STEEL MASTS

5 FT x .12" / .18"	Call
10 FT x .12" / .18"	Call
15 FT x .12" / 17 FT x .18"	Call
20 FT x .12" / 22 FT x .18"	Call
12 FT x .25" / 17 FT x .25"	Call

## GAP ANTENNAS

Challenger DX	Call
Challenger Counterpoise	Call
Challenger Guy Kit	Call
Eagle DX	Call
Eagle Guy Kit	Call
Titan DX	Call
Titan Guy Kit	Call
Voyager DX	Call
Voyager Counterpoise	Call
Voyager Guy Kit	Call

Please Call for Delivery Information

## LAKEVIEW HAMSTICKS

9106	6m	9115	15m	9130	30m
9110	10m	9117	17m	9140	40m
9112	12m	9120	20m	9175	75m

All handle 600W, 7' approximate length, 2:1 typical VSWR

## HUSTLER ANTENNAS

4BTV/5BTV/6BTV	Call
G6-270R, 2m/70cm Vertical	Call
G6-144B/G7-144B	Call

Hustler Resonators in stock-call

## ANTENNA ROTATORS

M2 OR-2800P	Call
Yaesu G-450A	Call
Yaesu G-800SA/DXA	Call
Yaesu G-1000DXA	Call
Yaesu G-2800SDX	Call
Yaesu G-550/G-5500	Call
<b>ROTATOR CABLE</b>	
R51(#20)/R52 (#18)	Call
R61 (#20)/R62 (#18)	Call
R81/82/83/84	Call

## PHILLYSTRAN GUY CABLE

HPTG1200I	Call
HPTG2100I	Call
PLP2738 Big Grip (2100)	Call
HPTG4000I	Call
PLP2739 Big Grip (4000)	Call
HPTG6700I	Call
PLP2755 Big Grip (6700)	Call
HPTG11200	Call
PLP2558 Big Grip (11200)	Call

Please call for more info or help selecting the Phillystran size you need.

WEEKDAY HOURS:  
9AM-5PM CST

SATURDAY HOURS:  
9AM-1PM CST

CREDIT CARDS:  
M/C, VISA, DISCOVER

# TEXAS TOWERS

A Division of Texas RF Distributors, Inc. • 1108 Summit Avenue, Suite #4 • Plano, TX 75074

# (800) 272-3467

LOCAL CALLS:  
(972) 422-7306

EMAIL ADDRESS:  
sales@texastowers.com

INTERNET ADDRESS:  
www.texastowers.com

# R&L Electronics

1315 Maple Ave HAMILTON, Oh 45011

Local/Tech 513-868-6399

(800)221-7735

http://randl.com email sales@randl.com

Fax 513-868-6574

Call, write,  
or email for a  
FREE catalog

Send \$2 for Express service

## RG-213/U

35 ¢ per foot

- Model # 2213
- 13 gauge center conductor
- 1.4db of loss/100 ft@50 Mhz

## RG-8/U

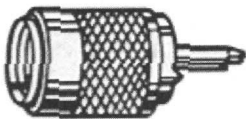
29 ¢ per foot

- Model # 2008
- 11 gauge center conductor
- 1.2db of loss/100 ft@50 Mhz

## RG-58/U

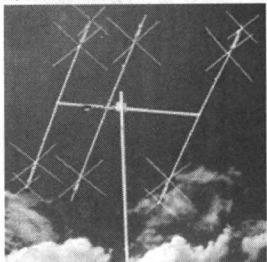
12 ¢ per foot

- Model # 1958
- 20 gauge center conductor
- 2.1db of loss/50 ft@50 Mhz



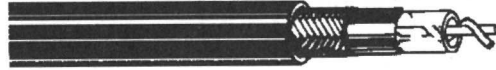
Amphenol PL-259s

PL259 Standard	\$ .95
PL259SP Silver Plated	\$1.50
PL259TFE Teflon	\$1.95
PL259SPTFE Silver & Teflon	\$2.95



**MA5B** Cushcraft's newest multiband HF antenna provides 5 band directivity in a package small enough to mount to a tripod. The MA5B is a design that does not sacrifice ruggedness, performance and power handling for size and ease of installation.

# Coax

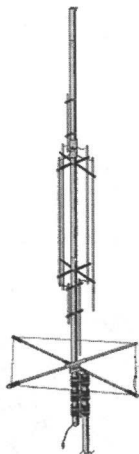


## 35 ¢ per foot

### 33 ¢ per foot in 500 ft spools Coax Equivalent to 9913

- Model # 2013
- Solid 9.5 gauge center conductor
  - Foil and Braid Shield
  - 84% Velocity Factor
- Poly semi solid center insulator
- 1.4db of loss per 100ft @ 100 Mhz

### 49 ¢ per foot w/stranded Center Conductor



**Titan DX** 8 Band Multiband DX Antenna Bands: 10m 12m 15m 17m 20m 30m 40m and 100 KHz on 80m, Bandwidth -- Under 2:1, Entire band on 40m 30m 20m 17m 15m 12m 10m, 100KHz on 80m, Height -- 25 ft, Weight -- 25 lbs, Mount : All hardware supplied except the 1 1/4" steel pipe. Counterpoise : 4 rigid counterpoises 80" long, Ground Area Required : None

## Butternut

**HF9VX** 80,40,30,20,17,15,12,10,6 meters. The finest home station in the world is no more effective than its antenna. Modest stations with good antennas run circles around more sophisticated powerful stations hobbled by poor antennas. No matter what power level you run or what environment is available to you it is always in your best interest to have the most efficient antenna you can manage. Unless you are a single band specialist multiband performance is mandatory for maximum use of your equipment and the hobby.

Prices as of 8/1/2000 subject to change without notice.

Call, write,  
or email for a  
FREE catalog

Send \$2 for Express service

### Coax Equivalent to 9913 w/stranded center conductor 49 ¢ per Foot

- Model # 2015
- Poly semi solid center insulator or foam insulator (2015F)
- 1.4db of loss @ 100 Mhz

## Mini 8/U

17 ¢ per foot

- Model # 1908
- 16 gauge center conductor
- 1.4db of loss/50 ft@50 Mhz

## Rotor Cable

- 8 conductor 22 ¢ per ft, Six 22 gauge two 18 gauge
- 8 conductor 34 ¢ per ft, Six 18 gauge two 16 gauge

## Spi-Ro

### Dipole Antenna

<b>MD6</b> 6m 9.5 ft long	\$19.95
<b>MD10</b> 10m 16.7 ft long	\$22.95
<b>MD15</b> 15m 22.3 ft long	\$22.95
<b>MD17</b> 17m 25.8 ft long	\$23.95
<b>MD20</b> 20m 33.4 ft long	\$23.95
<b>MD30</b> 30m 45.6 ft long	\$25.95
<b>MD40</b> 40m 66.9 ft long	\$26.95
<b>MD80</b> 80m 133.7 ft long	\$31.95
<b>MD160</b> 160m 260 ft long	\$42.95

### Shortened Dipole Kits

<b>LS40K</b> 40m 38 ft long	\$43.95
<b>LS80K</b> 80m 69 ft long	\$49.95
<b>LS160K</b> 160m 100 ft long	\$49.95

### Balun

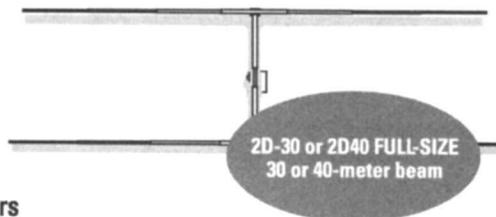
<b>PB1</b> 1:1 Balun	\$18.95
<b>PB1C</b> 1:1 Balun Current	\$21.95
<b>PB4</b> 4:1 Balun	\$23.95
<b>CE1</b> Center Insulator	\$9.95



# CAL-AV

## CAL-AV LABS, INC.

**Innovative Design... Solid Engineering... Modern Techniques...**  
*Experience the difference!*



### FULL-SIZE 2-Driven Element Rotatable Arrays for 30 and 40 Meters

Gain comparable to a 2-element parasitic; front to rear comparable to a 3-element parasitic. Pattern advantage over typical, shortened linear-loaded parasitics is even greater. Rated 3KW, CCS; Wind, 100MPH; UPS shippable

### FULL-SIZE Rotatable Dipoles for 30 and 40 Meters

Noticeably quieter than verticals or inverted-vees. Greater bandwidth than loaded, shortened dipoles. Rated 3KW, CCS; Wind, 100 MPH; UPS shippable

### High-performance Compact Transmitting Loops for 30 through 160 Meters

When properly installed over ground plane, will actually outperform a full-size "FCC" vertical, (i.e.  $\frac{1}{4}$  wave radiator, 120 radials of 0.4 wavelength) for DX. These are low-profile antennas. The highest part of an 80-meter loop, for example, is only 17 ft. above ground. Power ratings to 3KW, CCS. Consult factory.

### Balanced, Line-loaded Vertical Radiators for 30 through 160 Meters

High efficiency balanced vertical radiators for limited space. Operate with or without a ground plane, with or without guying, depending on installation requirements. To 3KW.

### Custom & Special designs for amateur and commercial applications

Aircraft, vehicular, and ground; VHF, UHF; consult factory.

### Baluns, lightning diverters, antenna components, and accessories

Wide band, high power baluns, custom and standard antenna components available.

For pricing, pictures, specifications, and patterns of our latest offerings, please see us at: [www.cal-av.com](http://www.cal-av.com)

**QUALITY & VALUE SINCE 1959**



# CAL-AV

[www.cal-av.com](http://www.cal-av.com)

[info@cal-av.com](mailto:info@cal-av.com)

1-520-624-1300, 1-520-624-1311 fax

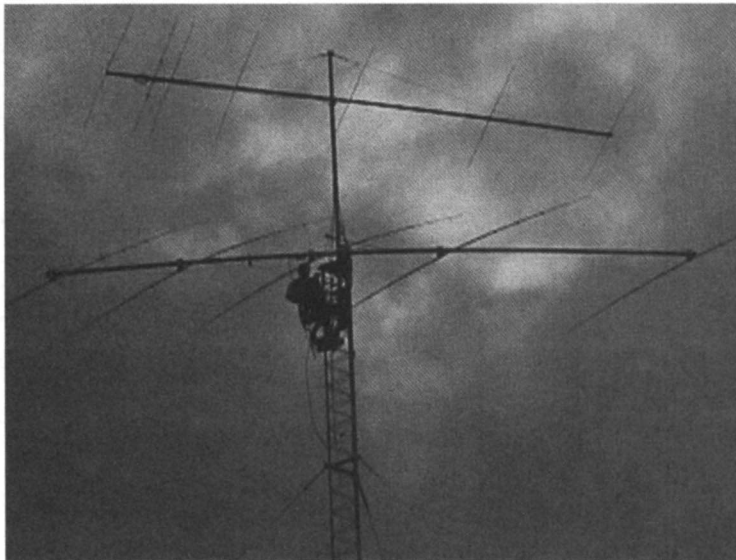
1-888-815-0400 orders only

1802 W. Grant Road, Suite 116 Tucson, AZ 85745

# XX Towers, Inc.



XX Towers, Inc. is a leading provider for all your communication needs. We provide complete installation and maintenance of tower/communication systems for ham and commercial applications.



- \*We're fully insured.
- \*Our experience comes from service on *thousands* of feet of tower!
- \*Recommended by M2 antennas and Ham Radio Outlet.
- \*We'd like to earn your trust too!

Company authorized ROHN dealer/installer

\*We travel everywhere.\*

## XX Towers, Inc.

814 Hurricane Hill Road, Mason, NH 03048

Phone: (603) 878-1102, Fax: (603) 878-4200, Web site: [www.xxtowers.com](http://www.xxtowers.com)

# Move Your Antenna System To The Microprocessor Age



## AT-11MP Autotuner

- Tunes 1.8 to 30 MHz
- Microprocessor controlled
- 5 to 150 watts
- Dual cross needle meters
- Features switched "L" network
- Requires 11 to 14 VDC
- Tunes any coax fed antenna
- Auto and Semiauto operation
- Tunes in .1 to 5 seconds
- True SWR sensing
- Remote head option for remote mounting
- IC-706 interface
- Purchase as kit or assembled

Kit with enclosure: \$199

Assembled: \$239

Remote Head kit: \$29

Remote Head assembled: \$39



## AT-11 Autotuner

- Tunes 1.8 to 30 MHz
- Microprocessor controlled
- 5 to 150 watts
- LED tuning status indications
- Features switched "L" network
- Requires 11 to 14 volts
- Tunes any coax fed antenna
- Auto and Semiauto operation
- Tunes in .1 to 5 seconds
- True SWR sensing
- Remote head option for remote mounting
- Optional IC-706 interface\*
- Purchase as kit or assembled

Kit with enclosure: \$160

Assembled: \$179

Interface: \$20

Remote Head kit: \$29\*

Remote Head assembled: \$39\*

(\* requires interface)

## DWM-4 Digital Wattmeter

- Monitors up to 4 radios
- Sensors available for HF, QRP, VHF, and UHF
- Microprocessor controlled
- Requires 11 to 14 VDC
- Programmable alarms
- Numeric or bar readout
- Program your callsign for display
- Mounting bracket included

Assembled with 2 Sensors: \$129

Additional Sensor: \$25

Special: \$99 with purchase of any assembled tuner



## BA-1 BALUN

- 4:1 BALUN
- 200 watts
- 1.8 to 30 MHz

Allows our tuners to tune your long, random, or ladder line antennas

Assembled: \$30

Kit with Enclosure: \$25

LDG Electronics, Inc.  
1445 Parran Road  
PO Box 48  
St. Leonard, MD 20685



Phone: 410 - 586 - 2177  
Sales (Toll Free): 877 - 890 - 3003  
Fax: 410 - 586 - 8475  
E-mail: sales@ldgelectronics.com

Secure On-line Ordering: <http://www.ldgelectronics.com>



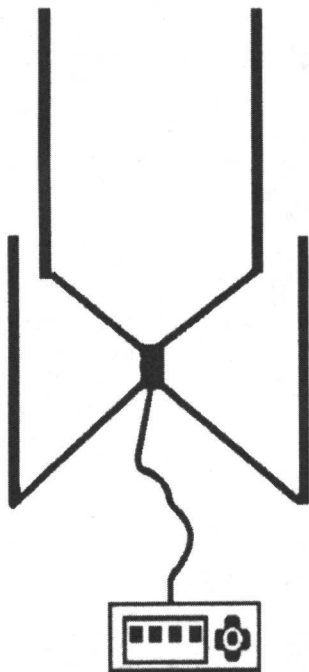
## *Comtek announces*

**New! SYS-3 STACK YAGI SWITCH for 2 OR 3 YAGI'S**  
Designed by K3LR, as described in his two part CQ Contest article

**NEW! RCAS-8 REMOTE ANTENNA SWITCH**  
MOV's & RF BYPASSING ON EACH OF THE SIX (6) CONTROL LINES

**NEW! VFA-4 Set of 4 vertical feedpoint assemblies**

**NEW! SRR-1 Stainless 60 hole Radial Rings**



**ComTek  
Systems**

### **COMTEK THE 4-SQUARE EXPERTS**

ACB-160	\$349.95
ACB-80	\$339.95
ACB-40	\$334.95
ACB-20	\$329.95
ACB-15	\$319.95
ACB-10	\$319.95

## **ComTek Systems**

*P. O. Box 470565, Charlotte,  
NC 28247*



**Tel: 704) 542-4808**



**FAX: (704) 542-9652**

**e-mail - comtek4@juno.com**

**www.comteksystems.com**

# MFJ 1.8-170 MHz SWR Analyzer™

## Reads complex impedance . . . Super easy-to-use

New MFJ-259B reads antenna SWR . . . Complex RF Impedance: Resistance(R) and Reactance(X) or Magnitude(Z) and Phase(degrees) . . . Coax cable loss(dB) . . . Coax cable length and Distance to fault . . . Return Loss . . . Reflection Coefficient . . . Inductance . . . Capacitance . . . Battery Voltage. LCD digital readout . . . covers 1.8-170 MHz . . . built-in frequency counter . . . side-by-side meters . . . Ni-Cad charger circuit . . . battery saver . . . low battery warning . . . smooth reduction drive tuning . . . and much more!

*The world's most popular SWR analyzer just got incredibly better and gives you more value than ever!*

MFJ-259B gives you a complete picture of your antenna's performance. You can read antenna SWR and Complex Impedance from 1.8 to 170 MHz.

You can read Complex Impedance as series resistance and reactance (R+jX) or as magnitude (Z) and phase (degrees).

You can determine velocity factor, coax cable loss in dB, length of coax and distance to a short or open in feet.

You can read SWR, return loss and reflection coefficient at any frequency simultaneously at a single glance.

You can also read inductance in uH and capacitance in pF at RF frequencies.

Large easy-to-read two line LCD screen and side-by-side meters clearly display your information.

It has built-in frequency counter, Ni-Cad charger circuit, battery saver, low battery warning and smooth reduction drive tuning.

Super easy to use! Just set the bandswitch and tune the dial -- just like your transceiver. SWR and Complex Impedance are displayed instantly!

### Here's what you can do

Find your antenna's true resonant frequency. Trim dipoles and verticals.

Adjust your Yagi, quad, loop and other antennas, change antenna spacing and height and watch SWR, resistance and reactance change instantly. You'll know exactly what to do by simply watching the display.

Perfectly tune critical HF mobile antennas in seconds for super DX -- without subjecting your transceiver to high SWR.

Measure your antenna's 2:1 SWR bandwidth on one band, or analyze multiband performance over the entire spectrum 1.8-170 MHz!

Check SWR outside the ham bands without violating FCC rules.

Take the guesswork out of building and adjusting matching networks and baluns.

Accurately measure distance to a short or open in a failed coax. Measure length of a roll of coax, coax loss, velocity factor and impedance.

Measure inductance and capacitance. Troubleshoot and measure resonant frequency and approximate Q of traps, stubs, transmission lines, RF chokes, tuned circuits and baluns.

Adjust your antenna tuner for a perfect 1:1 match without creating QRM.

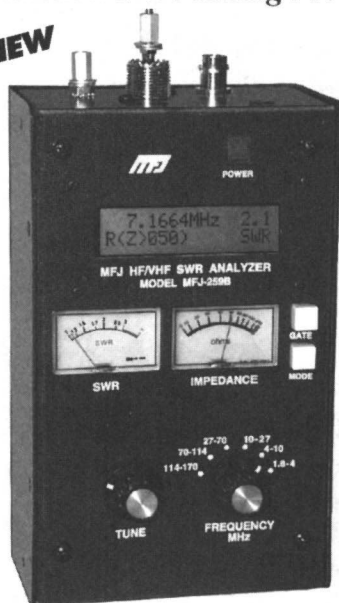
And this is only the beginning! The



MFJ-224 **MFJ 2 Meter FM Signal Analyzer™**  
**\$159<sup>95</sup>**

Measure signal strength over 60 dB range, check and set FM deviation, measure antenna gain, beamwidth, front-to-back ratio, sidelobes, feedline loss in dB. Plot field strength patterns, position antennas, measure preamp gain,

**NEW**



Call your favorite dealer for your best price!

MFJ-259B  
**\$259<sup>95</sup>**

MFJ-259B is a complete ham radio test station including -- frequency counter, RF signal generator, SWR Analyzer™, RF Resistance and Reactance Analyzer, Coax Analyzer, Capacitance and Inductance Meter and much more!

### Call or write for Free Manual

MFJ's comprehensive instruction manual is packed with useful applications -- all explained in simple language you can understand.

### Take it anywhere

Fully portable, take it anywhere -- remote sites, up towers, on DX-peditions. It uses 10 AA or Ni-Cad batteries (not included) or 110 VAC with MFJ-1315, \$14.95. Its rugged all metal cabinet is a compact 4x2x6 1/4 inches.

### How good is the MFJ-259B?

MFJ SWR Analyzers™ work so good, many antenna manufacturers use them in their lab and on the production line -- saving thousands of dollars in instrumentation costs! Used worldwide by professionals everywhere.

### More MFJ SWR Analyzers™

MFJ-249B, \$229.95. Like MFJ-259B, but reads SWR, true impedance magnitude and frequency only on LCD. No meters.

detect feedline faults, track down hidden transmitters, tune transmitters and filters. Plug in scope to analyze modulation wave forms, measure audio distortion, noise and instantaneous peak deviation. Covers 143.5 to 148.5 MHz. Headphone jack, battery check function. Uses 9V battery. 4x2 1/2 x 6 1/4 in.

MFJ-209, \$139.95. Like MFJ-249B but reads SWR only on meter and has no LCD or frequency counter.

MFJ-219B, \$99.95. UHF SWR Analyzer™ covers 420-450 MHz. Jack for external frequency counter. 7 1/2 x 2 1/2 x 2 1/4 inches. Use two 9 volt batteries or 110 VAC with MFJ-1312B, \$12.95. Free "N" to SO-239 adapter.

### SWR Analyzer Accessories

#### Dip Meter Adapter

MFJ-66, \$19.95. Plug a dip meter coupling coil into your MFJ SWR Analyzer™ and turn it into a sensitive and accurate bandswitched dip meter. Save time and take the guesswork out of winding coils and determining resonant frequency of tuned circuits and Q of coils. Set of two coils cover 1.8-170 MHz depending on your SWR Analyzer™.

#### Genuine MFJ Carrying Case

MFJ-29C, \$24.95. Tote your MFJ-259B anywhere with this genuine MFJ custom carrying case. Has back pocket with security cover for carrying dip coils, adaptors and accessories.

Made of special foam-filled fabric, the MFJ-29C cushions blows, deflects scrapes, and protects knobs, meters and displays from harm.

Wear it around your waist, over your shoulder, or clip it onto the tower while you work -- the fully-adjustable webbed-fabric carrying strap has snap hooks on both ends.

Has clear protective window for frequency display and cutouts for knobs and connectors so you can use your MFJ SWR Analyzer™ without taking it out of your case. Look for the MFJ logo for genuine authenticity!

MFJ-99, \$54.85. Accessory Package for MFJ-259/B/249/B/209. Includes genuine MFJ-29C carrying case, MFJ-66 dip meter adapter, MFJ-1315 110 VAC adapter. **Save \$5!**

**New! Tunable Measurement Filter™**  
MFJ-731, \$89.95. Exclusive MFJ tunable RF filter allows accurate SWR and impedance measurements 1.8 to 30 MHz in presence of strong RF fields. Has virtually no effect on measurements. Works with all SWR Analyzers.

### MFJ No Matter What™ warranty

MFJ will repair or replace (at our option) your MFJ SWR Analyzer™ for one full year.

### Free MFJ Catalog

Nearest Dealer . . . 800-647-1800

<http://www.mfjenterprises.com>

• 1 Year No Matter What™ warranty • 30 day money back guarantee (less s/h) on orders from MFJ

**MFJ ENTERPRISES, INC.**  
Box 494, Miss. State, MS 39762  
(662) 323-5869; 8-4:30 CST, Mon.-Fri.  
FAX: (662) 323-6551; Add s/h  
Tech Help: (662) 323-0549

Prices and specifications subject to change. © 2000 MFJ Enterprises, Inc.

**More hams use MFJ SWR Analyzers™ than any others in the world!**

# MFJ TUNERS

## MFJ-989C Legal Limit Antenna Tuner

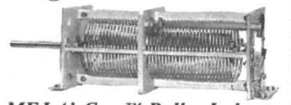
MFJ uses super heavy duty components to make the world's finest legal limit tuner

MFJ uses super heavy duty components -- roller inductor, variable capacitors, antenna switch and balun -- to build the world's most popular high power antenna tuner.

The rugged world famous MFJ-989C handles 3 KW PEP SSB amplifier input power (1500 Watts PEP SSB output power). Covers 1.8 to 30 MHz, including MARS and WARC bands.

MFJ's AirCore™ roller inductor, new gear-driven turns counter and weighted spinner knob gives you exact inductance control for absolute minimum SWR.

You can match dipoles, verticals, inverted vees, random wires, beams, mobile whips,



MFJ AirCore™ Roller Inductor gives high-Q, low loss, high efficiency and high power handling.

MFJ's exclusive Self-Resonance Killer™ keeps damaging self-resonances away from your operating frequency.

Large, self-cleaning wiping contact gives good low-resistance connection. Solid 1/4 inch brass shaft, self-align bearings give smooth non-binding rotation. MFJ No Matter What™ Warranty MFJ will repair or replace your MFJ-989C (at our option) no matter what for one year.

shortwave -- nearly any antenna. Use coax, random wire or balanced lines.

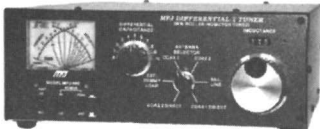
You get everything you've ever wanted in a high power, full featured antenna tuner -- widest matching range, lighted Cross-

Needle SWR/Wattmeter, massive transmitting variable capacitors, ceramic antenna switch, built-in dummy load, TrueCurrent™ Balun, scratch-proof Lexan front panel -- all in a sleek compact cabinet (10 1/4"Wx4 1/2"Hx15D in).

MFJ-989C  
**\$359<sup>95</sup>**

## More hams use MFJ tuners than all other tuners in the world!

### MFJ-986 Two knob Differential-T™



Two knob tuning (differential capacitor and AirCore™ roller inductor) makes tuning foolproof and easier than ever. Gives minimum SWR at only one setting. Handles 3 KW PEP SSB amplifier input power (1.5 KW output). Gear-driven turns counter, lighted peak/average Cross-Needle SWR/Wattmeter, antenna switch, balun. 1.8 to 30 MHz. 10 1/4"Wx4 1/2"Hx15 in.

### MFJ-962D compact Tuner for Amps



A few more dollars steps you up to a KW tuner for an amp later. Handles 1.5 KW PEP SSB amplifier input power (800W output). Ideal for Ameritron's AL-811H! AirCore™ roller inductor, gear-driven turns counter, pk/avg lighted Cross-Needle SWR/Wattmeter, antenna switch, balun, Lexan front, 1.8-30MHz. 10 1/4"x4 1/2"x10 1/8 in.

### MFJ-969 300W Roller Inductor Tuner



Superb AirCore™ Roller Inductor tuning. Covers 6 Meters thru 160 Meters! 300 Watts PEP SSB. Active true peak reading lighted Cross-Needle SWR Wattmeter, QRM-Free PreTune™, antenna switch, dummy load, 4:1 balun, Lexan front panel. 3 1/2"Hx10 1/2"Wx9 1/2"D inches.

### MFJ-949E deluxe 300 Watt Tuner

More hams use MFJ-949s than any other antenna tuner in the world! Handles 300 Watts. Full 1.8 to 30 MHz coverage, 48 position Precision48™ inductor, 1000 Volt tuning capacitors, full size peak/average lighted Cross-Needle SWR/Wattmeter, 8 position antenna switch, dummy load, QRM-Free PreTune™, scratch proof Lexan front panel. 3 1/2"Hx10 1/2"Wx7D inches. MFJ-948, \$129.95. Economy version of MFJ-949E, less dummy load, Lexan front panel.

### MFJ-941E super value Tuner

The most for your money! Handles 300 Watts PEP, covers 1.8-30 MHz, lighted Cross-Needle SWR/Wattmeter, 8 position antenna switch, 4:1 balun, 1000 volt capacitors, Lexan front panel. Sleek 10 1/2"Wx2 1/2"Hx7D in.

### MFJ-945E HF+6 Meter mobile Tuner

Extends your mobile antenna bandwidth so you don't have to stop, go outside and adjust your antenna. Tiny 8x2x6 in. Lighted Cross-Needle SWR/Wattmeter. Lamp and bypass switches. Covers 1.8-30 MHz and 6 Meters. 300 Watts PEP. MFJ-20, \$4.95, mobile mount.

### MFJ-971 portable/QRP Tuner

Tunes coax, balanced lines, random wire 1.8-30 MHz. Cross-Needle Meter. SWR, 30/300 or 6 Watt QRP ranges. Matches popular MFJ transceivers. Tiny 6x6 1/2"x2 1/2" inches.

### MFJ-901B smallest Versa Tuner

MFJ's smallest (5x2x6 in.) and most affordable wide range 200 Watt PEP Versa tuner. Covers 1.8 to 30 MHz. Great for matching solid state rigs to linear amps.

### MFJ-16010 random wire Tuner

Operate all bands anywhere with MFJ's reversible L-network. Turns random wire into powerful transmitting antenna. 1.8-30 MHz. 200 Watts PEP. Tiny 2x3x4 in.

### MFJ-906/903 6 Meter Tuners

MFJ-906 has lighted Cross-Needle SWR/Wattmeter, bypass switch. Handles 100 W FM, 200W SSB. MFJ-903, \$49.95. Like MFJ-906, less SWR/Wattmeter, bypass switch.

### MFJ-921/924 VHF/UHF Tuners

MFJ-921 covers 2 Meters/220 MHz. MFJ-924 covers 440 MHz. SWR/Wattmeter. 8x2 1/2"x3 inches. Simple 2-knob tuning for mobile or base.

### MFJ-922 144/440 MHz Tuner

Ultra tiny 4x2 1/2"x1 1/4" inch tuner covers VHF 136-175 MHz and UHF 420-460 MHz. SWR/Wattmeter reads 60/150 Watts.

### MFJ-931 artificial RF Ground

Creates artificial RF ground. Also electrically places a far away RF ground directly at your rig by tuning out reactance of connecting wire. Eliminates RF hot spots, RF feedback, TV/RFI, weak signals caused by poor RF grounding. MFJ-934, \$169.95, Artificial ground/300 Watt Tuner/Cross-Needle SWR/Wattmeter.

## Free MFJ Catalog

and Nearest Dealer . . . 800-647-1800

<http://www.mfjenterprises.com>

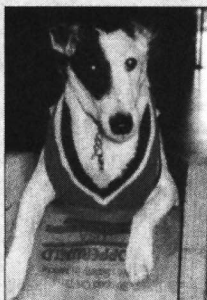
1 Year No Matter What™ warranty 30 day money back guarantee (less s/h) on orders from MFJ ENTERPRISES, INC. Box 494, Miss. State, MS 39762 (662) 323-5869; 8-4:30 CST. Mon.-Fri. FAX: (662) 323-6551; Add s/h Tech Help: (662) 323-0549

Prices and specifications subject to change. (c) 2000 MFJ Enterprises, Inc.



# CABLE X-PERTS, INC.

**JAKE, barks**  
**SAVE...SAVE...SAVE**  
 with our Monthly Specials.  
 For this month's special,  
 see the current issue of QST  
 or visit us on line at  
<http://www.cablexperts.com>



Shipping and handling applies to all other products and destinations listed herein.  
 • Minimum order: \$20.00 in product. • Prices subject to change without notice.  
 • Sorry, no C.O.D.'s. • Illinois residents 8.25% sales tax applies to all orders.

## COAX (50 OHM "LOW LOSS" GROUP)

	100FT/UP	500FT	1000FT
"FLEXIBLE" 9913 STRD BC CNTR FOIL + 95% BRAID 2.7dB @ 400MHz NC/DB/UV JKT.....	.58/FT	.56/FT	.54/FT
LMR 400 SOLID CCA CNTR FOIL + BRAID 2.7dB @ 450MHz WP/UV JKT.....	.59/FT	.57/FT	.55/FT
LMR 400 "ULTRA-FLEX" STRD BC CNTR FOIL + BRAID 3.1dB @ 450 MHz TPE JKT.....	.87/FT	.86/FT	.85/FT
LMR 600 (OD.590") SOLID CCA CNTR FOIL + BRAID 1.72dB @ 450 MHz WP/UV JKT.....	1.25/FT	1.22/FT	1.20/FT
LMR 600 "ULTRA-FLEX" STRD BC CNTR FOIL + BRAID 2.1dB @ 450MHz TPE JKT.....	1.95/FT	1.93/FT	1.90/FT

## COAX (50 OHM "HF" GROUP)

	100FT/UP	500FT	1000FT
RG213/U STRD BC MIL-SPEC NC/DB/UV JACKET 1.2 dB/2500WATTS @ 30MHz.....	.40/FT	.38/FT	.36/FT
RG8/U STRD BC FOAM 95% BRAID UV RESISTANT JKT 0.9dB/1350WATTS @ 30MHz.....	.34/FT	.32/FT	.30/FT
RG8 MINI(X)95% BRAID UV RESISTANT JACKET 2.0dB/875 WATTS @ 30MHz.....	.15/FT	.13/FT	.12/FT
RG58/U 95% BRAID UV RESISTANT JACKET 2.5dB/400 WATTS @ 30MHz.....	.15/FT	.13/FT	.11/FT
RG58A/U STRD CENTER 95% TC BRD UV RESISTANT JKT 2.6dB/350 WATTS @ 30MHz.....	.17/FT	.15/FT	.13/FT
RG214/U STRD SC 2 95% BRD NC/DB/UV JKT 1.2dB/1800WATTS @ 30MHz.....	.25FT/UP	1.75/FT.	
RG142/U SOLID SCCS 2-95% SILVER BRAIDS Teflon® JKT 8.2dB/1100WATTS @ 400MHz.....	.25FT/UP	1.50/FT.	

## COAX (75 OHM GROUP)

	100FT/UP	500FT	1000FT
RG11A/U STRD BC (VP-66%) 95% BRAID NC/DB/UV JKT 1.3dB/1000WATTS.....	.44/FT	.42/FT	.40/FT
RG6/U CATV FOAM 18GA CW FOIL + 60% ALUM BRAID.....	.20/FT	.13/FT	.11/FT
RG6/U CATV FOAM 18GA CW FOIL QUAD SHIELD.....	.25/FT	.18/FT	.16/FT

## LADDER LINE GROUP

	100FT/UP	500FT	1000FT
"FLEXIBLE" 450 OHM 16GA COMPRESSED STRD CCS(PWR-FULL LEGAL LIMIT+).....	.20/FT	.18/FT	.16/FT
"FLEXIBLE" 450 OHM 14GA COMPRESSED STRD CCS(PWR-FULL LEGAL LIMIT+).....	.25/FT	.24/FT	.23/FT
300 OHM 20GA STRD (POWER: FULL LEGAL LIMIT).....	.15/FT	.13/FT	.12/FT

## ROTOR & CONTROL CABLES

	100FT/UP	500FT	1000FT
5971 8/COND (2/18 6/22) BLK UV RES JKT. Recommended up to 125ft.....	.20/FT	.18/FT	.16/FT
1618 8/COND (2/16 6/18) BLK UV RES JKT. Recommended up to 200ft.....	.35/FT	.34/FT	.32/FT
1418 8/COND (2/14 6/18) BLK UV RES JKT. Recommended up to 300ft.....	.47/FT	.45/FT	.43/FT
1216 8/COND (2/12 6/16) BLK UV RES JKT. Recommended up to 500ft.....	.78/FT	.74/FT	.70/FT
1806 18GA STRD 6/COND PVC JACKET Recommended for Yaesu Rotors.....	.23/FT	.21/FT	.19/FT

## ANTENNA WIRE

	100FT/UP	300FT	500FT	1000FT
14GA 168 STRD "SUPERFLEX" (great for Quads & Portable set-ups etc.).....	.19/FT	.16/FT	.12/FT	.10/FT
14GA 7 STRD "HARD DRAWN" (perfect for permanent Dipoles etc.).....	.15/FT	.12/FT	.08/FT	.06/FT
14GA SOLID "COPPERWELD" (for long spans etc.).....	.15/FT	.12/FT	.08/FT	.06/FT
14GA SOLID "SOFT DRAWN" (for ground radials etc.).....	.15/FT	.12/FT	.08/FT	.06/FT

## ANTENNA & TOWER SUPPORT ROPE

	100FT/UP	250FT	500FT	1000FT
3/32" DOUBLE BRAID "POLYESTER" 260# TEST WEATHERPROOF.....	.075/FT	.06/FT	.045/FT	.04/FT
1/8" DOUBLE BRAID "POLYESTER" 420# TEST WEATHERPROOF.....	.10/FT	.08/FT	.07/FT	.057/FT
3/16" DOUBLE BRAID "POLYESTER" 770# TEST WEATHERPROOF.....	.15/FT	.12/FT	.09/FT	.08/FT
5/16" DOUBLE BRAID "POLYESTER" 1790# TEST WEATHERPROOF.....	.20/FT	.17/FT	.14/FT	.13/FT

## FLEXIBLE 2/COND RED/BLK DC POWER "ZIP" CORD

8GA (rated:40 amps) .....50FT \$24.50.....100FT \$44.50.....250FT \$107.50
10GA (rated:30 amps) .....50FT \$15.50.....100FT \$28.00.....250FT \$65.00
12GA (rated:20 amps) .....50FT \$10.50.....100FT \$19.00.....250FT \$42.50
14GA (rated:15 amps) .....50FT \$8.50.....100FT \$15.00.....250FT \$32.50
16GA (rated:12 amps) .....50FT \$5.50.....100FT \$10.00.....250FT \$22.50
18GA (rated: 8 amps) .....50FT \$4.50.....100FT \$8.00.....250FT \$17.50

<http://www.cablexperts.com>

FAX: 847-520-3444

TECH INFO: 847-520-3003

416 Diens Drive,  
Wheeling, IL 60090

HOURS: M-F 9AM-5PM CST.

ORDERS ONLY:

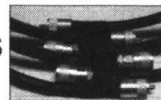
**800-828-3340**



# CABLE X-PERTS, INC.

## COAX CABLE ASSEMBLIES

with USA made Silver/Teflon® Gold Pin PL259 connectors.



FLEXIBLE 9913 strd BC cntr foil+95% braid 2.7dB 400MHz NC/DB/UV JKT.  
 200' \$129.<sup>95</sup> 175' \$114.<sup>95</sup> 150' \$99.<sup>95</sup> 125' \$84.<sup>95</sup> 100' \$69.<sup>95</sup> 75' \$54.<sup>95</sup> 50' \$39.<sup>95</sup>  
 25' \$24.<sup>95</sup> 15' \$21.<sup>95</sup> 10' \$18.<sup>95</sup> 6' \$12.<sup>95</sup> 3' \$11.<sup>95</sup> 1' \$10.<sup>95</sup>

RG213/U strd BC Mil-Spec NC/BD/UV JKT. 1.2dB 2500 watts @ 30MHz.  
 200' \$89.<sup>95</sup> 175' \$79.<sup>95</sup> 150' \$69.<sup>95</sup> 125' \$59.<sup>95</sup> 100' \$49.<sup>95</sup> 75' \$39.<sup>95</sup> 60' \$34.<sup>95</sup>  
 50' \$29.<sup>95</sup> 25' \$19.<sup>95</sup> 15' \$17.<sup>95</sup> 10' \$15.<sup>95</sup> 6' \$11.<sup>95</sup> 3' \$9.<sup>95</sup> 1' \$8.<sup>95</sup>

RG8/U strd BC foam 95% braid UV resistant JKT. 0.9dB 1350 watts @ 30MHz.  
 175' \$74.<sup>95</sup> 150' \$64.<sup>95</sup> 125' \$54.<sup>95</sup> 100' \$44.<sup>95</sup> 75' \$34.<sup>95</sup> 50' \$24.<sup>95</sup>  
 25' \$14.<sup>95</sup> 15' \$15.<sup>95</sup> 10' \$13.<sup>95</sup> 6' \$11.<sup>95</sup> 3' \$9.<sup>95</sup> 1' \$8.<sup>95</sup>

RG8 MINI(X) strd BC foam 95% braid UV resistant JKT. 2.0dB/875watts @ 30 MHz  
 150' \$34.<sup>95</sup> 125' \$30.<sup>95</sup> 100' \$26.<sup>95</sup> 75' \$22.<sup>95</sup> 50' \$18.<sup>95</sup> 25' \$14.<sup>95</sup>  
 CLR JKT: 18' \$12.<sup>95</sup> 12' \$11.<sup>95</sup> 10' \$10.<sup>95</sup> 6' \$9.<sup>95</sup> 3' \$8.<sup>95</sup> 1' \$7.<sup>95</sup>  
 18' PL259-Mini UHF Fem & PL259. \$21.<sup>95</sup>/ea.

With USA made Silver/Teflon®/Gold Pin male "N" connectors.

FLEXIBLE 9913 strd BC cntr foil+95% braid 2.7dB 400MHz NC/DB/UV JKT.  
 150' \$110.<sup>95</sup> 125' \$95.<sup>95</sup> 100' \$80.<sup>95</sup> 75' \$67.<sup>95</sup> 50' \$54.<sup>95</sup>  
 35' \$45.<sup>95</sup> 25' \$39.<sup>95</sup> 15' \$32.<sup>95</sup> 10' \$25.<sup>95</sup> 6' \$16.<sup>95</sup> 3' \$15.<sup>95</sup> 1' \$14.<sup>95</sup>

With USA made Silver/Teflon®/Gold Pin PL259 to male "N"

FLEXIBLE 9913 strd BC cntr foil+95% braid 2.7dB 400MHz NC/DB/UV JKT.  
 200' \$139.<sup>95</sup> 175' \$123.<sup>95</sup> 150' \$104.<sup>95</sup> 125' \$89.<sup>95</sup> 100' \$74.<sup>95</sup> 75' \$59.<sup>95</sup>  
 50' \$44.<sup>95</sup> 25' \$29.<sup>95</sup> 15' \$26.<sup>95</sup> 10' \$23.<sup>95</sup> 6' \$14.<sup>95</sup> 3' \$13.<sup>95</sup> 1' \$12.<sup>95</sup>

## RG142U 50 OHM COAX ASSEMBLIES

Double Silver Braid Shields, High Power Teflon® Dielectric & Jacket  
 PL259 ea end: 1ft \$9.<sup>95</sup> ea, 3ft \$12.<sup>95</sup> ea, 6ft \$17.<sup>95</sup> ea, 9ft \$21.<sup>95</sup> ea, 12ft \$26.<sup>95</sup> ea,  
 18ft \$36.<sup>95</sup> ea • "N" male ea end: 1ft \$13.<sup>95</sup> ea, 3ft \$18.<sup>95</sup> ea, 6ft \$21.<sup>95</sup> ea •  
 3 ft jumpers \$19.<sup>95</sup> ea: RA BNC male-"N" male, RA BNC male-"N" female,  
 SMA, male-BNC female, SMA female-"N" female, RA SMA male-"N" female,  
 SMA female-"N" male, SMA Male-"N" male.

## HT SOLUTION ASSEMBLIES

These jumpers will help improve the performance and life of your Hand Held Transceiver.  
 RG58A/U Group: 1ft R.A. SMA Male-SO239 (UHF Female) \$14.<sup>95</sup> ea • 1ft R.A. SMA  
 Male-"N" Female \$15.<sup>95</sup> ea • 1ft R.A. SMA Male-BNC Female \$14.<sup>95</sup> ea • 3ft R.A. SMA  
 Male-PL259 \$13.<sup>95</sup> ea. RG58/U Group: 3ft R.A. BNC Male-SO239 (UHF Female) \$14.<sup>95</sup> ea  
 3ft R.A. BNC Male-PL259 \$12.<sup>95</sup> ea. RG8X Mini Group: 6ft PL259-BNC Male \$9.<sup>95</sup> ea.

Assemblies Discounted: visit our website [www.cablexperts.com](http://www.cablexperts.com)

All connector terminations are soldered, Hi-Pot® tested @ 5kv for one minute, continuity  
 checked, ultra violet resistant heat shrink tubing, and red protective caps, which can also be  
 used as a boot.

## CONNECTORS

Both connectors fit 9913 types and LMR400 types MADE IN USA

PL 259 SILVER/Teflon®/GOLD TIP.....10PC \$12.50.....25PC \$27.50.....50PC \$52.50.....100PC \$100.00  
 "N" (2PC) SILVER Teflon®/GOLD TIP.....10PC \$37.50.....25PC \$87.50.....50PC \$162.50.....100PC \$300.00  
 For our other connectors and adapters see <http://www.cablexperts.com>

## TINNED COPPER "FLAT" GROUNDING BRAID

1 INCH WIDE (equivalent to 7ga).....25FT \$24.00.....50FT \$47.00.....100FT \$94.00  
 1/2 INCH WIDE (equivalent to 10ga).....25FT \$14.00.....50FT \$27.00.....100FT \$53.00  
 1/2 INCH x 6FT Copper Plated Ground Rod w/clamp.....\$7.00 each

## I.C.E. PRODUCTS

180A Beverage/Longwire matching unit.....\$39.00/ea  
 348 Rotor cable Line filter.....\$44.00/ea  
 303U Coax impulse suppressor 8 kW 1.5-200MHz.....\$44.00/ea  
 516R Remote RF power switch for up to 6 antennas.....\$184.00/ea  
 Individual Band Pass Filters.....\$35.00/ea  
 421 8kw <30 MHz Low Pass Filter.....\$58.00/ea  
 123B 1.8-2.0 MHz BANDPASS Preamplifier.....\$48.00/ea  
 Purchase two or more I.C.E. products on line & enjoy 10% off.

HELIX® LDF series from ANDREW® Corporation.

- Premium electrical performance.
- 100% RF shielding.
- 50 Ω Impedance.
- Very Low Loss Foam Dielectric.
- Use "N" and/or UHF connectors.
- Termination price: \$15.00/each.

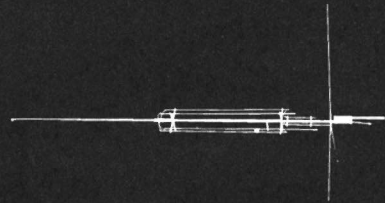
Teflon® is a registered trademark of DuPont.

Visit us on line at  
[www.cablexperts.com](http://www.cablexperts.com)  
 for, Discounts, Specials and to  
 get our complete catalog.



# GAP: THE PERFECT ANTENNA

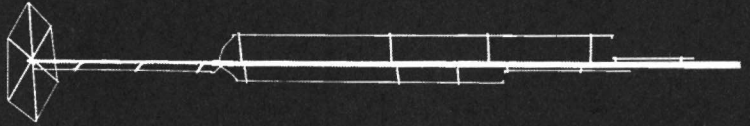
We at GAP realize there isn't a perfect antenna. No singular antenna will scream DX on 80 and be the best for local nets on 10. If anyone tells you there is, beware! The perfect antenna does not exist, but the right one for you may. If you want something to bust the pile on the low bands, then consider the Voyager. Just starting out in ham radio and need a great general coverage antenna, the Challenger is easy to assemble and for little effort will yield superior performance, especially on DX. Maybe you know-ingly or unknowingly moved into one of those "restricted areas" where the Eagle's limited visibility, but unlimited ability is desired.



Eagle DX



Challenger DX



Voyager DX

This chart helps you select the right GAP antenna. When comparing GAPs, bandwidth is not a concern. With few exceptions, a GAP yields continuous coverage under 2:1 for the ENTIRE BAND.

All antennas utilize a GAP elevated asymmetric feed. A major benefit is the virtual elimination of the earth loss, so more RF radiates into the air instead of the ground. This feed is why a GAP requires **NO RADIALS**. Just as elevating a GAP offers no significant improvement to its performance, adding radials won't either, making set up a breeze.

A **GAP antenna has no traps, coils or transformers**. This is important. The greatest sources of failure in multiband antennas are these devices. Perhaps you heard someone discuss a trap that had melted, arced or became full of water. Improvements to these inherent problems are the focus of the antenna manufacturer, while the basic design of the antenna remains unchanged. **GAP improved the trap by eliminating it!** Removing these devices means they don't have to be tuned and, more importantly, won't be detuned by the first ice or rain. The absence of these devices improves antenna reliability, stability and increases bandwidth.

Another major advantage to a GAP antenna is its NO tune feature. Screws are simply inserted into predrilled holes with a supplied nutdriver.

The secret is out and people in the know say:

**CQ**—"The GAP consistently outperformed base-fed antennas...and was quieter."

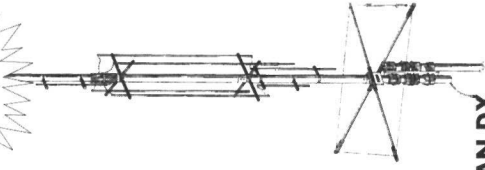
**73**—"This is a real DX antenna, much quieter than other verticals."

**RF**—"To say this antenna is effective would be a real understatement. Switching back and forth on 40m between another multiband HF vertical and the GAP, there was no comparison. Signals were always stronger on the GAP, sometimes by 5 units, not just DBs."

**Worldradio**—"These guys have solved the problem associated with verticals. That is, an awful lot of RF is wallowing around and dropping into the dirt instead of going outward bound. A half-wave vertical does need radials if it is end fed [at the bottom]. But the same half-wave vertical does not [as much, hardly at all] if it is fed in the center."

**IEEE**—"Near field and power density analyses show another advantage of this antenna (asymmetric vertical dipole): it decreases the power density close to the ground, and so avoids power dissipation in the soil below it. The input impedance is very stable and almost independent of ground conductivity. This antenna can operate with high radiation efficiency in the MF-AW standard broadcast band, without the classical buried ground plane, so as to yield easier installation and maintenance."

Celebrating  
10 Years  
1989-1999



TITAN DX

This all purpose antenna is designed to operate 10m-80m. WARC bands included. It sits on a 1-1/4" pipe and can be mounted close to the ground or up on a roof. Its bandwidth and no tune feature make it an ideal antenna for the limited space environment as well as a terrific addition to the antenna farm.



**TO ORDER, CALL**  
**(561) 571-9922**

Come Visit Us At [gapantenna.com](http://gapantenna.com)

**ANTENNA  
PRODUCTS INC.**  
99 N. Willow Street  
Fellsmere, FL 32948



MODEL	BANDS OF OPERATION										HT	WT	MOUNT	COUNTER-POISE	COST	
	2m	6m	10m	12m	15m	17m	20m	30m	40m	80m						160m
Challenger DX	■	■	■	■	■	■	■	■	■	■	■	31.5'	21 lbs	Drop In Ground Mount	3 Wires @ 25'	\$279
Eagle DX			■	■	■	■	■	■	■	■	■	21.5'	19 lbs	1-1/4" pipe	80" Rigid	\$289
Titan DX			■	■	■	■	■	■	■	■	■	25'	25 lbs	1-1/4" pipe	80" Rigid	\$319
Voyager DX											■	45'	39 lbs	Hinged Base	3 Wires @ 57'	\$399

**This Could Be One of the Most Useful Station Accessories You Will Ever Buy**—Whether You're on HF, VHF or UHF!

The Alpha Delta Model DELTA-4C Surge Protected Desktop Coaxial Switch Console. There Has Never Been Another Station Accessory that Offers the Antenna and Equipment Switching Convenience of This One



- The Model DELTA-4C, 4 position Coax Switch console is designed to sit conveniently next to your station equipment with no wall or desk mounting required. The connector and console design prevents coax cable from pulling the console backward. It stays put.
- The DELTA-4C retains the excellent performance features of the proven DELTA-4 switch series. In fact, the internal design is the same with micro-strip channels, positive detent switching and excellent co-channel isolation. The DELTA-4C can switch multiple antennas to your station, or multiple equipment to your antenna
- The DELTA-4C provides station surge protection with a built-in ARC-PLUG gas tube module, easily replaceable from the front panel. All circuits are protected during operation, and unused positions are grounded. A master center-off position grounds all circuits for maximum possible protection.
- The console is built with a heavy aluminum casting and "battleship" construction. Models offer both "SO-239" and type "N" connectors for complete versatility. The DELTA-4C Console is a wonderful addition to the family of DELTA-4 coax switches.

At your Alpha Delta Dealer or add \$5.00 ea. for U.S. order. Exports quoted

Model DELTA-4C Console, SO-239 Connectors, 4 Position ————— \$139.95 ea.  
Model DELTA-4CN Console, Type N Connectors, 4 Position ————— \$149.95 ea.

**ALPHA DELTA COMMUNICATIONS, INC.** **AA**

P.O. Box 620, Manchester, KY 40962

Phone (606) 598-2029 • Fax (606) 598-4413

**Toll Free Order Line: 888-302-8777**

Alpha Delta - Where Imagination And Reality Merge

Website: [www.alphadeltacom.com](http://www.alphadeltacom.com)

# 5 BAND QUAD

## \$289 2 Element Complete

Complete antenna from 20 meters to 70cm.  
Many models to choose from.  
UPS Shippable.

**Lightning Bolt Antennas**  
RD#2, RT 19, Volant, PA 16156  
724-530-7396 FAX 724-530-6796  
<http://lbq.isrv.com>

## Free to Download

### Active Beacon Wizard++

- > Supports NCDXF HF beacon system
- > See beacons on map w/terminator
- > Get current solar reports/forecasts
- > On-line help glossary solar terms

[www.taborsoft.com](http://www.taborsoft.com)

### Skywave Analysis with a Difference...

- > Best Band Graphs & Smart Reports
  - > Smart Map & editable database
  - > Requires win 3.1/95/98 & 486/ better
- ### WinCAP Wizard 2

> \$54.95, outside USA please +\$7

**Kangaroo Tabor Software**  
Rt. 2 Box 106, Farwell TX 79325-9430  
fax: 806-225-4006 [jim@taborsoft.com](mailto:jim@taborsoft.com)

VISA - MASTERCARD - CHECK - MONEY ORDER

### Free to drive! ABW++

- > Supports "awesome" NCDXF HF beacon system
- > View active beacon on topo map w/terminator
- > Get SEC solar reports & forecasts, up to 14
- > Help & SEC glossary of solar terrestrial terms

## Software for Active Hams

**FREE to download from:**

<http://www.taborsoft.com/>

Home of CAPMan & WinCAP Wizard 2

## Shortwave Receivers Past & Present

Communications Receivers 1942-1997

### RECEIVERS PAST & PRESENT



- New 3<sup>rd</sup> Ed.
- 108 Chapters
- 472 Pages
- 840 Photos
- Printed 03/98
- Covers 1942 to 1997.
- 770 Receivers
- 660 Variants
- Includes 98 U.S. and Intl. manufacturers
- Only \$24.95

This huge 472 page Third Edition includes over 770 shortwave and amateur communications receivers made from 1942 to 1997. Here is everything you need to know as a radio collector or informed receiver buyer. Entry information includes: receiver type, date sold, photograph, size & weight, features, reviews, specifications, new & used values, variants, value rating and availability. Ninety eight worldwide manufacturers are represented. 840 Photos. Become an instant receiver expert!

**universal radio inc.**

**Universal Radio**

6830 Americana Pkwy.  
Reynoldsburg, OH 43068

◆ Orders: 800 431-3939

◆ Info: 614 866-4267

[www.universal-radio.com](http://www.universal-radio.com)

**You Wouldn't Operate Your Equipment  
Without the Protection of an **ALPHA DELTA**  
Coax Surge Protector - Would You?**

Lightning and Static Induced Voltages From Nearby Discharges Can  
Couple Into Your Antenna and Cause Damage to Your Radios.



- Excellent broadband performance from DC thru 3 GHz, compared to the narrowband DC blocked or stub designs. Typical dB loss: 0.1@ 1 GHz; 0.2@ 2 GHz; 0.5@ 3 GHz.
- Innovative impedance compensated thru-line cavity design allows control voltages to pass thru the device, instead of the "wire around" requirement of DC blocked designs. Our design allows "in-circuit" cable sweeps.
- Innovative fast acting gas tube replaceable ARC-PLUG module can be removed and replaced in the field in about one minute with no tools required, and without having to remove the protector from the circuit. The "O" ring sealed knurled knob does the trick!
- The ARC-PLUG module and connectors are "O" ring sealed for complete weatherproofing.

**Toll free order line (888) 302-8777**  
**Website: [www.alphadeltacom.com](http://www.alphadeltacom.com)**

- Model ATT3G50, N Females, 3.0GHz (200W) .....\$59.95 ea.
- Model ATT3G50U, UHF Females, 500MHz (200W).....\$49.95 ea.
- 2kW versions of both models available at no extra cost; Please add -HP suffix to the appropriate model number

*Available at Alpha Delta dealers or factory direct.  
Please add \$5.00 Shipping/Handling if ordering direct  
Call for Commercial Versions & OEM Pricing*

**ALPHA DELTA COMMUNICATIONS, INC.** **AA**

P.O. Box 620, Manchester, KY 40962 • (606) 598-2029 • fax (606) 598-4413  
Alpha Delta - *Compelling You Into the 21st Century*

**GB HF ANTENNAS & TOWERS**

***HF/VHF/UHF/SHF Dual Band Yagis***

**WEB: [www.gbanttow.nl](http://www.gbanttow.nl) (photo's!)**

**E-mail: [gbanttow@wxs.nl](mailto:gbanttow@wxs.nl)**

**Tel.: 0031-181-410523**

**ALUMA**  
TOWER COMPANY, INC.

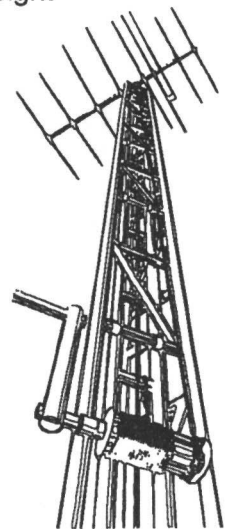
**C.G.A ENTERPRISES**  
P.O. Box 5026  
Hudson, FL 34674  
**Phone: 813-862-3325**

**Fax: 813-862-4767**  
**E-mail: [cga@mail.citicom.com](mailto:cga@mail.citicom.com)**  
Call David K4FRQ Toll Free At  
888-510-7373

**ALL ALUMINUM  
TOWERS**  
Crank-up & Tilt-over

- \* Trailer towers
- \* Van mounted towers
- \* Motor home towers

Maintenance Free  
Lightweight  
Strong



Also Available: Antennas, Rotors, Coax,  
Connectors, Radios, Power Supplies,  
Amplifiers, Batteries.

# HEX-BEAM<sup>®</sup>

- ▲ BIG SIGNAL
- ▲ SMALL BEAM
- ▲ LOW COST
- ▲ QUICK ASSEMBLY

... a new approach  
to beam design

[www.hexbeam.com](http://www.hexbeam.com)



MINIATURIZED CONTROLLED FIELD ANTENNAS

**Traffic Technology**

421 JONES HILL ROAD • ASHBY, MA 01431-1801  
978-386-7900 Phone/Fax • 1-888-599-BEAM Toll Free USA

**RADIOWARE**

**RBS**

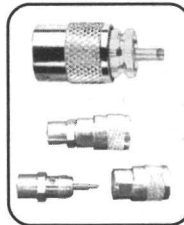
<http://www.radio-ware.com>

Check out our web site for the latest prices on coax, rotor cable, baluns, insulators, connectors, adapters, TVI filters, antenna wire, M<sup>2</sup> HF and VHF-UHF antennas and much more.



Featuring Davis Bury-Flex<sup>™</sup> 9914, low loss, direct burial coax. *Tuff-as-nails* outer jacket, flexible and designed for HF to UHF applications. Reasonably priced. Great Value!

We also stock Davis Flex-weave<sup>™</sup> antenna wire. Easy to work with and quite strong. We have bare and coated #12 and #14 wire in stock.



Looking for connectors? We have high quality Amphenol Silver plated PL-259s plus an easy-to-install, two piece N connector. Need to go from BNC to UHF? We have a large selection of adapters in stock to fit most needs.

Mon-Fri 10am-6pm \* Fax (603) 899 6826  
e-mail: [radware@radio-ware.com](mailto:radware@radio-ware.com)



**Radioware & Radio Bookstore**

PO Box 209

Rindge, NH 03461-0209 **(800) 457-7373**



## "STEALTH HAM ANTENNA"

*Your Zoning Solution!*

### Non-Directional Mobile Radio Antenna

- 36" x 2" Flexible Hoop - "CTHA"<sup>1</sup> Design
- Replaces Zone Ugly 66' Dipole Antennas •
- Transmits & Receives WorldWide with No "Parasitic Noise". Hides in your Apt., Closet, Attic, RV, Mobile Home, PU, Bicycle, Yard, Fence, Tree, anywhere!

From 3-30 MHz with Tuner, & VSWR Analyzer

30 Day Money Back Guarantee!

\*\$289.95 + \$9.95 S&H + COD

(\*With This Ad - Retail Price \$389.95)

Check/MO to JWM, Box 533, Red River, NM 87558

**1-800-435-SHOW**

<sup>1</sup> CTHA - Contrawound Toroidal Helical Antenna - Pat. 1997

See Our Web Site at: [www.nomosno.com/satellite](http://www.nomosno.com/satellite)



# ADVANCED ANTENNA ANALYSTS™



The VA1 does more than others!  
**VA1 RX Analyst**  
 0.5 to 32 MHz  
**\$199.95 + S/H**

- Freq ● SWR ● True Impedance
  - Series & Parallel R & X ● Sign of X
  - Series L & C ● Phase (deg)
  - Much more. Check out our Web page!
- Don't be misled by others which claim to measure X but don't read sign of X, and can't even tell a capacitor from a coil! The VA1 instantly shows sign, and is not limited to 50 ohm line.



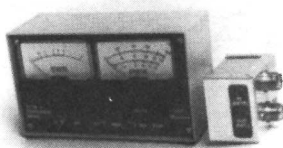
**RF1 RF Analyst**  
 1.2 to 35 MHz  
 Frequency. SWR.  
 True Impedance. L&C.  
 Advanced, but low priced  
**\$129.95 + S/H**



**RF5 VHF Analyst**  
 35 to 75 MHz & 138 to 500 MHz. Similar to RF1 but no direct L/C. Finds lowest SWR automatically.  
**\$229.95 + S/H**

Each Analyst has a low power "transmitter" to go anywhere in its range—even outside ham bands. Use any to measure SWR curves, feedline loss, impedance, baluns, electrical length (e.g. 1/4 wave lines.) Take one right to the antenna or measure at the transmitter end of the line. Accurately adjust Yagis, quads, slopers, dipoles, phased arrays, matching networks, radials, and so much more. Adjust tuner without transmitting. The RF1 measures "lumped" L and C directly, while the VA1's phase detector can separate out R and X (L/C) separately; you're not "half blind" by knowing only SWR or unsigned X. Each is microprocessor-based & palm sized, only about 8 oz.—about the size of the battery pack in others!. Each uses a single 9V standard battery.

## DELUXE SWR & WATTMETER



**MODEL WM1**  
**COMPUTING SWR**  
**REMOTE RF HEAD**  
**TRUE PEP & AVERAGE**  
**NEW - Illuminated Meters**  
 Compare at \$200 +  
**\$132.95 + S/H**

Our WM1 gives you exactly what you want—SWR ON ONE METER AND POWER ON THE OTHER. Automatically computes SWR. SWR doesn't change with power. No more squinting at crossed needles. NO ADJUSTMENTS. It even reads SWR in PEP on SSB. 4 ft. cable to head avoids "meter pull-off." 5% FS 1-30 MHz, usable on 6M, 2KW, 200, and 20 W scales with 5W center for QRP. 8-18 VDC or 115 VAC. 6-3/8x3-3/4x3" d. (See excellent review Nov. 1989 QST.) Why use an inferior meter? Get yours today!

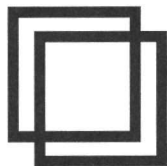
## Autek Research

P.O. Box 8772  
 Madeira Beach, FL 33738  
**727-397-8155**

Order only direct with check, mo, MC, VISA.  
 Add \$6 S/H in 48 states. Add tax in FL. Add \$11 to AK, HI \$16 Canada. \$25 to most worldwide locations. Speedy insured shipment.

For much more info and combo discounts, check in at:

<http://www.autekresearch.com>



# CUBEX

## Quad Antennas

**"A 40 + YEAR TRADITION"**

Quad antennas - 2m, 6m, & HF 10m thru 40m

Check our website - [www.cubex.com](http://www.cubex.com)

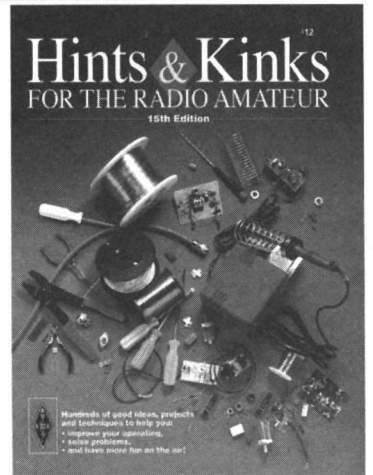
Write Or Call For Free Catalog

228 HIBISCUS ST. #9, JUPITER, FL 33458

(561) 748-2830 FAX (561) 748-2831

# You call them fun... We call them Hints & Kinks

**NEW 15th Edition**



**Overloaded with weekend projects, and ways you can improve your gear, antennas, operating, and more.**

**Separate chapters cover:**

- Equipment Modifications
- Batteries and Generators
- Mobile and Portable Stations
- Equipment Construction and Maintenance
- Test Gear **Resourceful**
- Antenna Systems **Creative**
- Operating **Fun!**
- Suppliers

Plus, you'll find easy to follow suggestions for solving all types of interference problems!

This book features the entire "Hints & Kinks" column published from 1997 through 1999, and additional articles from the columns "New Ham Companion" and "The Doctor is IN."

**Hints & Kinks**  
 for the Radio Amateur

ARRL Order No. 7903

Only \$12\*

\*shipping: \$4 US  
 \$5.50 International



**ARRL**

225 Main Street, Newington, CT 06111

email: [pubsales@arrl.org](mailto:pubsales@arrl.org)

<http://www.arrl.org/>

Toll-Free 1-888-277-5289

Phone 860-594-0355

fax 860-594-0303

QT5/2000